

INTERNATIONAL CONFERENCE ON EDUCATION IN
**MATHEMATICS,
SCIENCE &
TECHNOLOGY**

PROCEEDING BOOK

ICEMST2014

MAY 16 - 18, 2014
KONYA / TURKEY

EDITORS

Assoc. Prof. Dr. İsmail ŞAHİN
Assist. Prof. Dr. S. Ahmet KIRAY
Res. Asst. Selahattin ALAN



NECMETTİN ERBAKAN
UNIVERSITY



AHMET KELEŞOĞLU
FACULTY OF EDUCATION

www.icemst.com

ICEMST 2014

INTERNATIONAL CONFERENCE ON
EDUCATION IN
MATHEMATICS, SCIENCE & TECHNOLOGY
MAY 16 – 18, 2014

PROCEEDING BOOK

EDITORS

Assoc. Prof. Dr. İsmail ŞAHİN
Assist. Prof. Dr. S. Ahmet KIRAY
Res. Asst. Selahattin ALAN

DESIGNED BY

Res. Asst. İsmail ÇELİK

*Necmettin Erbakan University, Ahmet Kelesoglu Education Faculty
Meram, 42099, KONYA / TURKEY*

ISBN: 978-605-61434-3-4



CONFERENCE PRESIDENT

Prof. Dr. Muzaffer ŞEKER (Rector of Necmettin Erbakan University)

ADVISORY BOARD

Prof. Dr. Mehmet Emin AYDIN (Vice Rector, Necmettin Erbakan University)

Prof. Dr. Muhsin KAR (Vice Rector, Necmettin Erbakan University)

Prof. Dr. Tahir YÜKSEK (Vice Rector, Necmettin Erbakan University)

Prof. Dr. Ali Murat SÜNBL (Dean, Ahmet Keleşoğlu Faculty of Education)

Prof. Dr. Mustafa PEHLİVAN (Dean, Ereğli Faculty of Education)

Assoc. Prof. Dr. Dursun YAĞIZ (Associate Dean, Ahmet Keleşoğlu Faculty of Education)

Assoc. Prof. Dr. Mehmet KIRBIYIK (Associate Dean, Ahmet Keleşoğlu Faculty of Education)

Assoc. Prof. Dr. Zekeriya MIZIRAK (General Secretary, Necmettin Erbakan University)

SCIENTIFIC BOARD

Prof.Dr. Ann D. THOMPSON - Iowa State University, U.S.A

Prof.Dr. Bill COBERN - Western Michigan Univ., U.S.A.

Prof.Dr. Douglas B. CLARK - Vanderbilt University, U.S.A.

Assoc.Prof.Dr. Erhan ERTEKİN – N.E. University, Turkey

Assoc.Prof.Dr. Ertuğrul USTA – Mevlana University, Turkey

Assoc.Prof.Dr. Gokhan OZDEMİR - Nigde Univ., Turkey

Assoc.Prof.Dr. Gultekin CAKMAKCI - Hacettepe U., Turkey

Assoc.Prof.Dr. Harun YILMAZ- TUBITAK, Turkey

Assoc.Prof.Dr. Huseh-Hua CHUANG – N.S.Y. Univ., Taiwan

Assoc.Prof.Dr. İlhan VARANK - Yıldız Tech. Univ., Turkey

Assoc.Prof.Dr. I. Ozgur ZEMBAT - Mevlana Univ., Turkey

Prof.Dr. James M. LAFFEY - University of Missouri, U.S.A.

Prof.Dr. Kamisah OSMAN - National University, Malaysia

Prof.Dr. Lynne SCHRUM - George Mason University, U.S.A.

Prof.Dr. Mack SHELLEY - Iowa State University, U.S.A.

Prof.Dr. Mary B. NAKHLEH - Purdue University, U.S.A.

Prof.Dr. Mehmet AYDENİZ – Univ. of Tennessee, U.S.A.

Assoc.Prof.Dr. Musa DIKMENLİ – N. E. University, Turkey

Assoc.Prof.Dr. Ömür AKDEMİR – B.E. University, Turkey

Assoc.Prof.Dr. Özgen KORKMAZ – Mevlana Univ., Turkey

Assoc.Prof.Dr. Pasha ANTONENKO – O. S. U., U.S.A.

Prof.Dr. Paul ERNEST - University of Exeter, UK

Prof.Dr. Pornrat WATTANAKASIWICH – C.M.U., Thailand

Prof.Dr. Robert E. YAGER - University of Iowa, U.S.A.

Prof.Dr. Sanjay SHARMA - Roorkee E&M Tech. Ins., India

Prof.Dr. Sevilay ATMACA - Cyprus Intern. Univ., Cyprus

Assoc.Prof.Dr. Sinan ERTEN - Hacettepe University, Turkey

Dr. Tsung-Hau JEN - National Taiwan Normal Univ., Taiwan

Prof. Dr. William F. MCCOMAS – Univ. of Arkansas, U.S.A.

Assoc.Prof.Dr. Yılmaz SAGLAM - Gaziantep Univ., Turkey

ORGANIZING COMMITTEE

Assoc.Prof.Dr. İsmail ŞAHİN

Assoc.Prof.Dr. Ahmet ERDOĞAN

Assoc.Prof.Dr. Hakan AKÇAY

Assoc.Prof.Dr. Mustafa DOĞAN

Assoc.Prof.Dr. Osman ÇARDAK

Lect. Halil İbrahim ÖZER

Lect. Ahmet AYDOĞDU

Lect. A.Subutay KAYA

Lect. Hamza KAYNAR

Lect. Mehmet BEKMEZCİ

Lect. Özkan AKMAN

Lect. Mevlüt AYDOĞMUŞ

Res.Asst. Selahattin ALAN

Res.Asst. İsmail ÇELİK

Res.Asst. Şirin KÜÇÜK

Res.Asst. Abdulkadir ÖNER

Res.Asst. Niyazi GÜNDOĞMUŞ

Res.Asst. Eyüp YURT

Res.Asst. Kürşat ÖĞÜLMÜŞ

Res.Asst. Mustafa AYDIN

Lect.Dr. Özgül BALCI

Res.Asst. Vural TÜNKLER

Lect. Kevser ÇINAR

Assist.Prof.Dr. S. Ahmet KIRAY

Assist.Prof.Dr. Rukiye KONUK ER

Assist.Prof.Dr. Abdullah Erdal TÜMER

Assist.Prof.Dr. Ahmet Oğuz AKTÜRK

Assist.Prof.Dr. Şemseddin GÜNDÜZ

Assist.Prof.Dr. Ersin BOZKURT

Assist.Prof.Dr. Esme HACİEMİNOĞLU

Assist.Prof.Dr. Harun ŞİMŞEK

Assist.Prof.Dr. Oktay ASLAN

Assist.Prof.Dr. Alpaslan DURMUŞ

Assist.Prof.Dr. Sinan KAYA

Assist.Prof.Dr. Mesture KAYHAN ALTAY

Assist.Prof.Dr. Yakup YILMAZ

Lect. Dr. Agâh Tuğrul KORUCU

Res.Asst.Dr. Derya ÇINAR

Res.Asst.Dr. Nilüfer CERİT BERBER

Lect. Davut ALAN

Lect. Mustafa HEBEBCİ

Lect. Ayşe KÖK

Lect. Huriye DALGIÇ

Lect. Mehmet BEKMEZCİ

Lect. Fetah EREN

Lect. Merve SADETAŞ SEZER

PREFACE

Greetings!

We are congregating scientists, researchers and students who keep on involving their studies on education all over the world via International Conference on Education in Mathematics, Science and Technology which took place on May 16 - 18, 2014, at Necmettin Erbakan University in Konya, Turkey. We are honored to organize this event at Necmettin Erbakan University. By this opportunity, all the participants were able to develop scientific knowledge and scientific exchange through this well organized conference. In addition, they were able to spend a few restful days on the rich historical and cultural ambiance of Konya.

About 400 people from 30 different countries participated in the conference. A total of 359 academic works were presented at this event. We would like to acknowledge by expressing our deepest gratitude to keynote speakers, Prof. Dr. Paul ERNEST from University of Exeter-UK, Prof. Dr. William F. MCCOMAS from University of Arkansas-USA, Prof. Dr. Mack SHELLEY from Iowa State University-USA, Assoc. Prof. Dr. Jacqueline T. MCDONNOUGH from Virginia Commonwealth University-USA, and Prof. Dr. Lynne SCHRUM from West Virginia University-USA, for accepting our invitation to present a keynote speech in our conference. We thank to the panelists, Prof. Dr. Giray BERBEROGLU from Middle East Technical University-Turkey and Assoc. Prof. Dr. Gultekin CAKMAKCI from Hacettepe University-Turkey, for their valuable presentations. We also would like to thank to the members of the organization committee who contribute with their intense efforts for this conference and our sponsors, Private Genclik Schools, Private Basak College, Yargi Academy, Egitim Publication, and TUBITAK for their support.

The Organization Committee

TABLE OF CONTENTS

USING COMPUTER AND ICT EQUIPMENT FOR E-TEACHING AND E-LEARNING: ISSUES AND CHALLENGES FACING TEACHERS	1
CRÈCHE AND SAFETY FACILITIES FOR INFANT DEVELOPMENT	13
PERSPECTIVES OF IRANIAN SECONDARY SCHOOL TEACHERS TOWARDS THE APPLICATION OF INTERACTIVE WHITEBOARDS TECHNOLOGY IN MATH CLASSES.....	17
THE EFFECT OF USING SMART BOARD TECHNOLOGY ON IRANIAN EFL.....	29
USEFULNESS OF SPSS SUPPORT FOR STUDENTS OF ECONOMICS AND BUSINESS	30
COMPARISON OF DIFFERENTIATED APPROACH DEVELOPED WITH PURDUE MODEL IN TERMS OF ACHIEVEMENT	40
EDUCATION AND THE CHALLENGES OF SUSTAINABLE LIVELIHOOD IN EMERGING ECONOMIES: FOCUS ON RURAL ADULT EDUCATION FOR POVERTY REDUCTION IN NIGERIA.....	41
ROLE OF HISTORY OF MATHEMATICS ON EDUCATION OF MATHEMATICS	42
THE USE OF X-RAY ANALYSIS TO STUDY THE RELATIONSHIP BETWEEN MICROSTRUCTURE AND IONIC CONDUCTIVITY OF $CSAG_{2-x} TL_xI_3$	46
INTERACTION EFFECTS OF TEACHER-PRESENCE AND STUDENTS' ACHIEVEMENT LEVEL OF SCIENCE.....	54
PHYSICS WITH COMPUTER-AIDED LEARNING.....	54
MADDEYİ TANIYALIM ÜNİTESİNİN ELEŞTİREL DÜŞÜNME YÖNTEMİYLE ÖĞRETİMİNİN ÖĞRENCİLERİN ÜST DÜZEY DÜŞÜNME BECERİLERİNE ETKİSİ	61
8. SINIF ÖĞRENCİLERİNİN RUTİN OLMAYAN PROBLEMLER KARŞISINDA KULLANDIKLARI STRATEJİLER.....	68
TEACHERS ' VIEW ON EDUCATIONAL RESEARCH.....	73
GEOGEBRA DESTEKLİ ORTAMLARDA ÖĞRENCİLER ARASI ETKİLEŞİMLERİN İNCELENMESİ.....	74
DENEYLE DESTEKLENMİŞ PROBLEME DAYALI ÖĞRENMENİN FEN VE TEKNOLOJİ DERSİNDEKİ BAŞARIYA ETKİSİ	75
THE STUDY OF THE EFFECTIVENESS OF APPLYING THE CONSTRUCTIONAL APPROACH IN MATERIALIZING THE GOALS OF THE CURRICULUM OF THE INTELLIGENT SCHOOLS.....	79
A SURVEY OF INFLUENCE OF ENVIRONMENT AS A MOTIVATOR ON SECONDARY SCHOOL STUDENTS' PERFORMANCE IN MATHEMATICS IN NIGERIA	86
CEBİRSEL MUHAKEME DEĞERLENDİRME ARACI: ARAÇ GELİŞTİRME, GÜVENİRLİK VE GEÇERLİK ÇALIŞMASI.....	93
TEACHING THE FUTURE TEACHERS: MAKING SCIENCE RELEVANT, USEFUL AND MEANINGFUL FOR NEW ZEALAND PRE-SERVICE TEACHERS.....	99
NO YOUTH LEFT BEHIND: REFLECTIONS FROM UNDERGRADUATE MATHEMATICS	110
THE DICHOTOMOUS MARKOV PROCESS WITH NONPARAMETRIC TEST APPLICATION; A DECISION SUPPORT METHOD IN LONG-TERM RIVER BEHAVIOURAL ANALYSIS	115
FACILITATING STUDENTS' GEOMETRIC THINKING THROUGH VAN HIELE'S PHASE-BASED LEARNING USING TANGRAM.....	116
EFFECT OF GENDER, AGE AND MATHEMATICS ANXIETY ON COLLEGE STUDENTS' ACHIEVEMENT IN ALGEBRA.....	117

“I AM UN/SUCCESSFUL IN MATHEMATICS BECAUSE...” : STUDENTS’ SELF-PERCEIVED COMPETENCE IN MATHEMATICS	122
BRAİD FOLDİNG AND BURAU REPRESENTATION	123
AN ASSESSMENT TOWARDS THE PUBLICATINONS OF UNESCO ABOUT MATHEMATICS EDUCATION (1989-2013)	137
INTEGRATING MATHEMATICS AND SCIENCE WITH ICT: A PROBLEM-CENTERING STRATEGY IN A GREEK SECONDARY SCHOOL	149
SCIENCE TEACHERS’ PERSPECTIVES ON BENEFITS AND PROBLEMS FACED USING TABLET COMPUTERS IN SCIENCE EDUCATION: THE STORY FROM A SECONDARY SCHOOL IN TURKEY	154
ORTAOKUL 6. SINIF ÖĞRENCİLERİN MATEMATİĞE VE MATEMATİKÇİLERE BAKIŞ AÇILARI	155
A NEW METHOD FOR SOLVİNG BLACK-SCHOLES PARTİAL DİFFERENTIAL EQUATION	157
PREDICTING STUDENTS’ ACADEMIC PERFORMANCE USING ARTIFICIAL NEURAL NETWORK : A CASE STUDY FROM FACULTY OF ORGANIZATIONAL SCIENCES	158
METHOD OF PROTECTİNG EDUCATİONAL CERTİFİCATES FROM FORGERY	164
INFORMING THE PRACTICE OF MATHEMATICS TEACHİNG IN THE UPPER PRIMARY CLASSES	168
ASSESSİNG TEACHER'S PERFORMANCE IN THE LIGHT USING TECHNOLOGICAL TOOLS IN TEACHİNG AND ITS RELATIONSHIP TO THE STUDENT'S PERFORMANCE AND THEIR ATTİTİDES TOWARD MATHEMATICS EDUCATİON.....	173
ŞİFRELEME ETKİNLİĞİNİN MATEMATİK DERSLERİNDE KULLANIMINA BİR ÖRNEK.....	178
EFFECTS OF PARENTAL ROLES IN STUDENTS’ MATHEMATICAL LEARNING: HOW DOES THE EDUCATION LEVEL OF PARENTS EFFECT THEIR INVOLVEMENT?	183
STUDENTS OPİNİON ABOUT EXTRA CURRICULAR EXERCİSES WHICH PERFORMED WITHİN THE SCOPE OF PROJECT BASED LEARNING	189
FEN BİLGİSİ EĞİTİMİ İÇİN WEB TABANLI ÖĞRENME	190
THE İMPACT OF LESSON STUDY ON PRIMARY MATHEMATICS TEACHERS’ İNSTRUCTİONS İN BRUNEİ DARUSSALAM.....	197
ORTAOKUL 5. SINIF MATEMATİK DERS KİTABININ ÖĞRETMEN VE ARAŞTIRMACI GÖRÜŞLERİNE GÖRE.....	202
STUDENTS’ ATTİTİDES TOWARDS TECHNOLOGY EDUCATİON İN FINLAND, ESTONIA AND İCELAND.....	203
YAN ALANI MATEMATİK ÖĞRETMENLİĞİ OLAN ÖĞRETMENLERİN MATEMATİK ÖĞRETİMİNE YÖNELİK GÖRÜŞLERİ.....	208
THE AWARENESS OF PRE-SERVİCE TEACHERS ABOUT LİVİNG THİNGS AS A FUNDAMENTAL CONCEPT ON TEACHİNG SOCİOSCİENTİFİC İSSUES	209
PERCEPTİONS OF PRE-SERVİCE TEACHERS ABOUT İNSTRUCTİONAL TECHNOLOGY: THE FİNDİNGS OF A QUALİTATİVE STUDY	210
THE ROLE OF BELİFS ON UNİVERSİTY MATHEMATICS TEACHERS' PROFESSIONAL KNOWLEDGE DEVELOPMENT	211
TURKİSH CHEMİSTRY TEACHERS’ VIEWS ABOUT SECONDARY SCHOOL CHEMİSTRY CURRICULUM: A PERSPECTİVE FROM ENVIRONMENTAL EDUCATİON.....	217
APPLICATİON FOR TRACKİNG STUDENTS’ EFFİCİENCY AND PREDİCTİNG EXPECTATİONS BASED ON CURRENT RESULTS.....	224

SEKİZİNCİ SINIF ÖĞRENCİLERİNİN HİSTOGRAM GRAFİĞİNİ OLUŞTURMA, YORUMLAMA VE ANLAMLANDIRMA SÜRECİNE İLİŞKİN BİR DURUM ÇALIŞMASI	229
A REVIEW OF CRITERIA FOR CONTENT SELECTION IN PRIMARY EDUCATION CURRICULUM. (IN IRAN)	230
GENEL LİSE ÖĞRENCİLERİNİN FATİH PROJESİNİN KULLANIM DÜZEYİNE İLİŞKİN GÖRÜŞLERİ.....	235
THE DEVELOPMENT OF AN INQUIRY BASED LEARNING UNIT FOR INTEGRAL CALCULUS: THE CASE OF VOLUMES OF SOLIDS OF REVOLUTION	241
WEB TASARIMI VE PROGRAMLAMA DERSİ İÇİN WEB TABANLI EĞİTİMİN ÖĞRENME ÜZERİNE ETKİSİ.....	248
SINIF ÖĞRETMENLİĞİ ÖĞRENCİLERİNİN TEKNOLOJİK PEDAGOJİK ALAN BİLGİSİ ÖZ YETERLİK DURUMLARININ BELİRLENMESİ	253
EXAMINATION OF VISUALS IN MIDDLE SCHOOL SCIENCE TEXTBOOKS	259
NON-MATHEMATICS STUDENTS' REASONING IN NON-ROUTINE CALCULUS TASKS	260
5. SINIF “VÜCUDUMUZ BİLMECESİNİ ÇÖZELİM” ÜNİTESİ BAŞARI TESTİ: GEÇERLİK VE GÜVENİRLİK.....	271
THE EFFECT OF INTERDISCIPLINARY NATURE EDUCATION PROGRAM ON GIFTED AND TALENTED STUDENTS' PROBLEM SOLVING SKILLS	276
SYNTHESIS, SPECTROSCOPIC, AND BIOLOGICAL STUDIES OF CHROMIUM(III), MANGANESE(II), IRON(III), COBALT(II), NICKEL(II), COPPER(II), RUTHENIUM(III), AND ZIRCONYL(II) COMPLEXES OF N1, N2 - BIS (3 - ((3 - HYDROXYNAPHTHALEN - 2 - YL) METHYLENE - AMINO) PROPYL) PHTHALAMIDE.....	277
IDENTIFICATION LOCAL MATTER TYPICAL SOUTH SUMATRA TO DEVELOP MODEL OF LEARNING BASED CONTRUCTIVISM FOR ENVIRONMENT LITERACY ON JUNIOR HIGH SCHOOL STUDENT IN INDONESIA	289
KO TE ARO WHAKAMURĪ KĪA ANGA WHAKAMUA. REFLECT ON THE PAST IN ORDER TO FORGE THE FUTURE.	296
ASRIN SU PROJESİ: KUZEY KIBRIS ORTAÖĞRETİM ÖĞRENCİLERİNDE SU TÜKETİMİNE VE ÇEVREYE YÖNELİK FARKINDALIK	297
INVESTIGATING THE DISTINCTIVE ROLE OF THE INTERACTIVE WHITEBOARDS FOR MATHEMATICS TEACHING.....	306
FATİH PROJESİYLE İLGİLİ AMPİRİK ÇALIŞMALARIN ANALİZİ: BİR LİTERATÜR TARAMASI317	
ADAPTATION OF TECHNOLOGICAL PEDAGOGICAL CONTENT KNOWLEDGE (TPACK) AND TECHNOLOGY INTEGRATION SELF-EFFICACY SCALE (TISE) INTO TURKISH	322
THE DERIVATIVE GRAPHAS WITH NUMERIC AND GRAPHICS APPROACH.....	323
DEVELOPING INNOMATTS TO IMPROVE MATHEMATICS TEACHERS' PEDAGOGICAL AND PROFESSIONAL COMPETENCES: AN INDONESIAN PERSPECTIVE	324
İLKOKUL 4.SINIF MADDEYİ TANIYALIM ÜNİTESİNE YÖNELİK BİR BAŞARI TESTİ GELİŞTİRME ÇALIŞMASI	336
SOME RESULTS ON CYCLIC CODES OVER $F^2 + uF^2 + vF^2 + uvF^2$	341
ZEKÂ OYUNLARI DERSİNE İLİŞKİN.....	342
ÖĞRETMEN VE ÖĞRENCİ GÖRÜŞLERİ.....	342
ORTAOKUL ÖĞRENCİLERİNİN PROBLEM ÇÖZME TUTUMLARININ ÇEŞİTLİ DEĞİŞKENLER AÇISINDAN İNCELENMESİ ÜZERİNE BİR ARAŞTIRMA	343

AN EXAMİNİNG OF MİDDLE SCHOOL STUDENTS' METACOGNİTİVE SKİLLS AND MATHEMATİCS	350
ORTAOKUL ÖĐRENCİLERİNİN BİLİMSSEL YARATICILIKLARININ FEN LABORATUVARI DENEYİMLERİ İLE GELİŐTİRİLMESİ.....	351
BİLİMSSEL SÜREÇ BECERİLERİ ETKİNLİKLERİNİN ORTAOKUL ÖĐRENCİLERİNİN BİLİMSSEL BİLGİYE YÖNELİK GÖRÜŐLERİNE ETKİSİ	356
ENHANCİNG STUDENT LEARNİNG THROUGH USE OF ONLİNE TECHNOLOGİES	357
AN EXAMİNİNG OF MİDDLE SCHOOL STUDENTS' SELF-EFFICACY TOWARD GEOMETRY AND ATTİTUDES TOWARDS MATHEMATİCS	358
THE EXPERIENCE OF TEACHİNG STATİSTİCS TO NON-SPECIALİST STUDENTS İN SAUDİ UNİVERSİTİES: THE ROLE OF TECHNOLOGY AND LANGUAGE	359
MODERN İCT SOLUTIONS TO BE TAUGHT İN TOURİSM AND HOSPİTALİTY EDUCATION: EVALUATION AND İMPLİCATIONS.....	366
DEVELOPİNG AND EVALUATİNG PHYSİCS TEACHİNG MATERİAL WİTH ALGODOO (PHUN) İN VİRTUAL ENVİRONMENT;	371
AKADEMİSYENLERİN TABLET PC KULLANIMI HAKKINDAKİ GÖRÜŐLERİ: SÜLEYMAN DEMİREL ÜNİVERSİTESİ ÖRNEĐİ.....	376
VERİ MADENCİLİĐİ TEKNİKLERİ KULLANILARAK ORTAOKUL ÖĐRENCİLERİNİN MATEMATİK ÖĐRENME STİLLERİ İLE MATEMATİK DERSİNE YÖNELİK TUTUMLARININ VE ARALARINDAKİ İLİŐKİLERİN İNCELENMESİ	377
PROJECT MATHS İN İRELAND:.....	384
THE EFFECT ON İNTERNATİONAL STUDENTS.....	384
ÖĐRETMEN ADAYLARININ TEMEL MATEMATİKSEL İFADELERİN DOĐRULUĐUNA YÖNELİK GÖRÜŐLERİ	391
HİZMET ÖNCESİ FEN ÖĐRETMENLERİNİN LİSE ÖĐRENİMLERİNDEKİ LABORATUVAR YAŐANTILARI.....	392
İNVESTİGATİNG PRE-SERVİCE MATHEMATİCS TEACHERS' VIEWS ABOUT VECTOR APPROACH TO GEOMETRY AND İNSTRUCTİONAL METHODS DURING GEOMETRY TEACHİNG	398
ORTAOKUL 7.SİNİF ÖĐRENCİLERİNİN UZAY ARAŐTIRMALARI KONUSUNDAKİ ALTERNATİF KAVRAMLARININ BELİRLENMESİ.....	399
SAMPLE VİSUAL ARTS ACTIVİTİES İNTEGRATED İNTO PROBLEM BASED LEARNİNG METHOD İN SCİENCE COURSES.....	405
İS PREZİ MORE USEFULLNESS EDUCATION TOOL THAN POWERPOİNT?.....	406
İÇERİK YÖNETİM SİSTEMİ KULLANILABİLİRLİK DEĐERLENDİRMEŐİ: JOOMLA 3.....	411
DEVELOPİNG OF LEARNİNG MANAGEMENT SYSTEM (LMS) AS AN EFFORT İN İNCREASİNG LEARNİNG EFFECTİVENESS AND LEARNİNG ACTIVİTİES OF STUDENTS İN SRIWİJAYA UNİVERSİTY	416
TÜBİTAK WEB SİTESİNİN KULLANILABİLİRLİĐİNİN FARKLI YÖNTEMLER İLE DEĐERLENDİRİLMESİ.....	421
DEVELOPİNG GEOMETRICAL THINKİNG THROUGH MATHEMATİZATİON.....	426
EFFECT OF PROSPECTİVE SCİENCE TEACHERS' SCİENCE LABORATORY SELF-EFFICACY AND ATTİTUDE SCORES AND PHYSİCS, CHEMİSTRY AND BİOLOGY LABORATORY ANXİETY SCORES İN TERMS OF SOME VARIABLES.....	430
ASSESSİNG AND UPGRADİNG THE REALİTY OF E-LEARNİNG AT TİKİRİT UNİVERSİTY	431

ORTAOKUL KADEMLERİNE YÖNELİK FEN VE MATEMATİK PROJE YARIŞMALARININ DEĞERLENDİRİLMESİ: TRABZON ÖRNEĞİ	435
ANALYSIS OF MATHEMATICAL PROBLEM SOLVING PROCESSES OF 6TH GRADE STUDENTS USING THE THINK-ALOUD PROTOCOL	436
FEN VE ETKNOLOJİ DERSİNDE BİLGİSAYAR DESTEKLİ PROJE TABANLI ÖĞRENME MODELİ UYGULAMALARI.....	437
EXAMINATION OF SCIENCE TEACHER'S PEDAGOGICAL CONTENT KNOWLEDGE IN THE TOPICS RELATED TO ACIDS AND BASES	438
İLKÖĞRETİM MATEMATİK ÖĞRETMENİ ADAYLARININ LİSANSÜSTÜ EĞİTİME YÖNELİK TUTUMLARININ BULANIK MANTIK İLE BELİRLENMESİ	439
LİSELERDEKİ PERFORMANS GÖREVLERİ HAKKINDA ÖĞRETMEN GÖRÜŞLERİ.....	440
LİSE ÖĞRENCİLERİNİN FEN BİLİMLERİNDE KULLANILAN.....	441
ÖLÇÜ BİRİMLERİYLE İLGİLİ BİLGİ DÜZEYLERİ VE DÜŞÜNCELERİ.....	441
PRE-SERVICE SCIENCE TEACHERS' IMAGES OF PHYSICIST AND PHYSICS COURSE.....	446
MATEMATİK ÖĞRETMEN ADAYLARININ ÇİN KALAN TEOREMİ İLE İLGİLİ SOYUTLAMAYI İNDİRGE ME EĞİMLERİ	451
SEÇMELİ MATEMATİK UYGULAMALARI DERSİNİ ALAN VE ALMAYAN 5. SINIF ÖĞRENCİLERİNİN MATEMATİĞE YÖNELİK TUTUMLARININ KARŞILAŞTIRILMASI	456
A PRELIMINARY STUDY FOR DYSCALCULIA IN SABAH, MALAYSIA.....	462
“YEŞİL KUTU” ÇEVRE EĞİTİMİ PROJESİNİN FEN VE TEKNOLOJİ ÖĞRETMEN ADAYLARININ ÇEVRE DOSTU DAVRANIŞLARINA ETKİSİ.....	471
THE EFFECT OF COMPUTER ASSISTED LABORATORY APPLICATIONS ON PRESERVICE TEACHERS' ATTITUDES TOWARDS SCIENCE TEACHING	478
RETHINKING THE MEANING OF INTERNATIONAL LARGE-SCALE ASSESSMENT	479
DEVELOPMENT AND VALIDATION OF A SCALE TO MEASURE CHEMISTRY LABORATORY ANXIETY LEVEL OF UNIVERSITY STUDENTS.....	480
DEVELOPMENT AND VALIDATION OF A SCALE TO MEASURE BIOLOGY LABORATORY ANXIETY LEVEL OF UNIVERSITY STUDENTS.....	481
KNOWLEDGES FOR EFFECTIVE INTEGRATION OF MATHEMATICS AND SCIENCE.....	482
AN AUTOMATED SCORING APPROACH FOR ESSAY	488
LİSE ÖĞRENCİLERİNİN NÜKLEER ENERJİ HAKKINDAKİ BİLGİ DÜZEYLERİ.....	493
CEBİR ÖĞRETİMİNDE ÇOKLU TEMSİL TEMELLİ ÖĞRETİMİN YERİ VE ÖNEMİ	498
METHODICAL AND MULTIMEDIA ENVIRONMENT FOR THE ACQUISITION OF ICT COMPETENCES IN THE FIELD OF LOGO PROGRAMMING OF FUTURE COMPULSORY EDUCATION TEACHERS	503
ORTAOKUL FEN VE TEKNOLOJİ DERSLERİNDE LABORATUVAR KULLANIMINA YÖNELİK ÖĞRENCİ GÖRÜŞLERİ	508
EXAMINATION OF ATTITUDES OF COMPULSORY EDUCATION TEACHERS IN THE REPUBLIC OF CROATIA TOWARD THE INTEGRATION OF ICT TECHNOLOGY IN DAILY WORK	513
BAZI ELEKTRİK KAVRAMLARI ÜZERİNE SEMİYOTİK YAKLAŞIMIN NASIL KULLANILDIĞINA İLİŞKİN BİR DURUM ÇALIŞMASI.....	520
ÖĞRETMEN ADAYLARININ ÖĞRETİM TEKNOLOJİLERİ VE MATERYAL TASARIMI DERSİNE YÖNELİK TUTUMLARI İLE ÖĞRETMEN ÖZ-YETERLİLİKLERİ ARASINDAKİ İLİŞKİNİN ANALİZİ	525

ÖĞRETMENLERİN CİNSEL SAĞLIK BİLGİ DÜZEYLERİ	526
TÜRKİYE VE ÇİN-TAYVAN 8. SINIF DÜZEYİ MATEMATİK ÖĞRETİM PROGRAMLARININ VE TIMSS SONUÇLARININ KARŞILAŞTIRILMASI	527
IMPACTS OF ERGONOMICS ON SUDANESE HIGHER EDUCATION INSTITUTIONS ICT CLASS ROOMS	528
FARKLILAŞTIRILMIŞ FEN VE TEKNOLOJİ ÖĞRETİMİNİN ÜSTÜN ZEKALİ VE YETENEKLİ ÖĞRENCİLERİN TUTUMLARINA ETKİSİ	533
PROSPECTİVE MATHEMATİCS TEACHERS' PREFERENCES FOR INSTRUMENTAL ORCHESTRATION TYPES AND ENDORSED	534
BİLİM SÖZDE-BİLİM AYRIMI BAĞLAMINDA PLANLANMIŞ ÖĞRETİM SÜRECİNİN ORTAOKUL ÖĞRENCİLERİNİN AKADEMİK BİLGİ DÜZEYLERİNE ETKİSİ	535
YILDIZLAR KONUSUNUN ÖĞRETİMİNE YÖNELİK BİR DERS MATERYALİNİN GELİŞTİRİLMESİ, UYGULANMASI VE ETKİLİLİĞİNİN DEĞERLENDİRİLMESİ.....	536
2005 VE 2013 FEN BİLİMLERİ DERSİ ÖĞRETİM PROGRAMINA GÖRE HAZIRLANMIŞ 5. SINIF DERS KİTAPLARINDA YER ALAN ETKİNLİKLERİN ÇEŞİTLİ YÖNLERDEN İNCELENMESİ	541
TURKISH VERSION OF STATISTICAL REASONING ASSESSMENT (SRA).....	542
HOW DO THE PUPİLS' PARENTS TAKE A STAND TO THE STUDYİNG OF THE CRAFTS İN FİNLAND?	543
OKUL ÖNCESİ EĞİTİMDE STEM UYGULAMALARINA YÖNELİK ÖĞRETMEN GÖRÜŞLERİ..	544
5. SINIFLAR İÇİN GELİŞTİRİLEN BİLİMİN DOĞASI ETKİNLİLERİNİN ETKİLİLİĞİ.....	549
ÖĞRETMEN ADAYLARININ BİLİMSSEL EPİSTEMOLOJİK İNANÇLARINDAKİ DEĞİŞİM ÜZERİNE KARŞILAŞTIRMALI BİR ÇALIŞMA.....	556
YAŞAM TEMELLİ ÖĞRENME YAKLAŞMIYLA 8. SINIF “SIVILARIN VE GAZLARIN KALDIRMA KUVVETİ” KONUSUNUN ÖĞRETİMİ	561
İLKOKUL ÖĞRENCİLERİNE YÖNELİK TEMEL BECERİ ÖLÇEĞİNİN TÜRKÇEYE UYARLAMA ÇALIŞMASI.....	572
ÜNİVERSİTE ÖĞRENCİLERİNİN SOSYAL PAYLAŞIM SİTELERİNE YÖNELİK ALGILARININ İNCELENMESİ.....	573
EXAMİNİNG THE ITEM-WORDİNG EFFECT ON THE SELF-REPORT SCALE	597
MATEMATİK KAYGISI VE ENDİŞESİNİN CİNSİYET, SINIF DÜZEYİ VE OKUL TÜRÜ BAKIMINDAN İNCELENMESİ.....	598
ÜNİVERSİTE ÖĞRENCİLERİNİN MATEMATİĞİN TEMELLERİNE İLİŞKİN FELSEFİ GÖRÜŞLERİ.....	599
BİREYSEL GELİŞİM DOSYASI, ÜSTBİLİŞSEL FARKINDALIK ve AKADEMİK BAŞARI ARASINDAKİ İLİŞKİNİN İNCELENMESİ	600
THE İNVESTIGATION OF CONTENT KNOWLEDGE OF	606
AN EFFECT OF HAVING İNTERNET ACCESS ON PROSPECTIVE EARLY CHILDHOOD TEACHERS' İNNOVATİVENESS PROFILES.....	613
BİR DURUM ÇALIŞMASI: ORTAOKUL ÖĞRENCİLERİNİN ORANTISAL AKIL YÜRÜTME PROBLEMLERİNİ ÇÖZME SÜREÇLERİNİN, STRATEJİLER VE PROBLEM DEĞİŞKENLERİ AÇISINDAN İNCELENMESİ.....	614
THE USE OF ADOBE CONNECT AND OPENMEETİNGS İN DISTANCE EDUCATION	616
AN ANALYSIS OF MATHS LEARNING SUPPORT FOR MATURE STUDENTS İN ENGINEERİNG: ENGAGEMENT AND EFFECT.....	623
WEB BASED EDUCATIONAL SOFTWARE FOR ARTİFİCİAL NEURAL NETWORKS	629

MATEMATİK ÖĞRETMENLİĞİ ALAN BİLGİSİ SINAVLARINDAKİ SORULARIN MATH TAKSONOMİ ÇERÇEVESİNDE ANALİZİ	633
BİÇİMLENDİRİCİ DEĞERLENDİRMENİN MATEMATİK BAŞARISINA VE HATIRLAMAYA ETKİSİ.....	638
THE OPINIONS OF TEACHER CANDIDATES ABOUT THEIR TEACHER TRAINING COURSES	649
ÖZEL ÖĞRETİM YÖNTEMLERİ II DERSİNDE GERÇEKLEŞTİRİLEN UYGULAMALARIN KİMYA ÖĞRETMEN ADAYLARI TARAFINDAN DEĞERLENDİRİLMESİ	654
SOLVING A NUMBER PLACEMENT GAME USING RECURSIVE BACKTRACKING ALGORITHM ON THE GRAPH MODEL	656
BİYOLOJİ DERSLERİNDE AKILLI TAHTA KULLANIMINA İLİŞKİN ÖĞRENCİ TUTUMLARI..	663
KARİKATÜRLERİYLE DESTEKLENEN FEN VE TEKNOLOJİ ÖĞRETİMİNİN ÖĞRENCİLERİN AKADEMİK BAŞARILARINA ETKİSİ	664
EXAMINATION OF TEACHER CANDIDATES' METAPHORS RELATED TO TEACHER EDUCATION PROGRAMS	670
DETERMINATION OF STUDENT TEACHERS' VIEWS ABOUT REACT STRATEGY	675
FEN BİLGİSİ ÖĞRETMEN ADAYLARININ GELİŞTİRDİKLERİ BENZEŞİMLER (ANALJİLER) ÜZERİNE BİR ARAŞTIRMA	680
IN-SERVICE SCIENCE TEACHER PROFILES FROM THE EYES OF PRE-SERVICE SCIENCE TEACHERS: WHAT DID THEY OBSERVE?	681
STUDENTS' TALK DURING COLLABORATIVE GROUP DISCUSSION	684
BİYOLOJİ ÖĞRETMEN ADAYLARININ MEMELİLER HAKKINDAKİ GÖRÜŞLERİ	689
ARGUMENTATION IN PEER-GUIDED VERSUS TEACHER-GUIDED GROUP DISCUSSIONS....	690
BESİN ZİNCİRİ VE BESİN AĞI KONULARINDA YARATICI DRAMA ETKİNLİKLERİ: ÖRNEK BİR DERS İŞLEYİŞİ	695
REHBERLİKLİ KEŞFETME VE ETKİLİ ÖĞRENME.....	699
ÇEVRE EĞİTİMİ PROJESİNİN ÖĞRENCİLERİN BİLİŞSEL YAPILARI ÜZERİNE ETKİSİ	704
ANALYSIS OF PRESERVICE ELEMENTARY TEACHERS VISUAL MATHEMATICS LITERACY	705
TEKNOLOJİ DESTEKLİ ÇOKLU TEMSİL TEMELLİ ÖĞRETİME ÖRNEK BİR UYGULAMA.....	706
TEKNOLOJİ DESTEKLİ ÇOKLU TEMSİL TEMELLİ ÖĞRETİMİN ÖĞRENCİLERİN LİNEER CEBİR BAŞARISINA ETKİSİ	711
ORTAOKUL 4. SINIF ÖĞRENCİLERİNİN EŞİTSİZLİK KONUSUNDAKİ SOYUTLAMA SÜREÇLERİNİN RBC MODELİ BAĞLAMINDA İNCELENMESİ	716
STUDENTS PERCEPTIONS ABOUT EFFECTS OF TEACHERS' CHARACTERISTICS ON STUDENTS MATH ACHIEVEMENT	721
HAZIRLIK SINIFI ÖĞRENCİLERİNİN YABANCI DİL DERSLERİNDE BİLGİ VE İLETİŞİM TEKNOLOJİLERİ KULLANILMASINA YÖNELİK TUTUMLARI	722
ARAŞTIRMAYA DAYALI FEN LABORATUARI UYGULAMALARININ ÖĞRETMEN ADAYLARININ YARATICI DÜŞÜNME DÜZEYLERİNE ETKİSİ.....	723
PROSPECTIVE ELEMENTARY TEACHERS' PERCEPTIONS OF USING TECHNOLOGY IN THE TEACHING OF MATHEMATICS.....	729
USING SLOWMATION AS A TEACHING APPROACH AND ITS EFFECT ON BIOLOGY ACHIEVEMENTS OF PRE-SERVICE SCIENCE TEACHERS	730
ÇOCUKLARIN TEMİZ VE KİRLİ ÇEVRE ALGILARI	736

ERADICATING MATHEMATICS ANXIETY AMONG SECONDARY SCHOOL STUDENTS USING COGNITIVE BEHAVIOURS THERAPY (CBT)	737
EFFECTS CONSTRUCTIVIST BASED INSTRUCTIONAL STRATEGY ON STUDENTS' LEARNING OUTCOME IN MATHEMATICS	741
ELEKTRİK AKIMI VE İLGİLİ KONULARA AİT ÖĞRETME DURUMLARININ PRAKSEOLOJİK ANALİZİ	747
CONCEPT CARTOON SAMPLES INTEGRATED INTO PROBLEM BASED LEARNING IN SCIENCE COURSES*	748
EFFECTS OF PROBLEM BASED LEARNING ON PROSPECTIVE SCIENCE TEACHERS' ATTITUDES TOWARDS BIOLOGY LABORATORY	749
GÜNEY KORE VE TÜRKİYE'DEKİ ÖĞRENCİLERİN MATEMATİK BAŞARILARI İLE AİLE İŞLEVSELLİĞİ ALGILARININ İLİŞKİSİ	750
10. SINIF ÖĞRENCİLERİNİN ÖTELEME VE DÖNME DÖNÜŞÜMLERİYLE İLGİLİ MATEMATİKSEL ANLAMALARININ GELİŞİMİNDE SANAL MANİPÜLATİFLERİN ROLÜ.....	755
FEN BİLİMLERİ ÖĞRETMENLERİNİN ALTERNATİF ÖLÇME DEĞERLENDİRME ARAÇLARINI KULLANMA DURUMLARI	756
GRAFİK HESAP MAKİNESİ İLE TRİGONOMETRİ ÖĞRETİMİ: BİR EYLEM ARAŞTIRMASI	757
MATEMATİK DERSİNE YÖNELİK TUTUM GELİŞTİRME İLE İLGİLİ YAPILMIŞ ARAŞTIRMALARA BİR BAKIŞ	759
ÖĞRETMEN ADAYLARININ, TAMSAYI TARİFİNDE ÇOCUKLARIN NEREDE VE NEDEN KARIŞIKLIK YAŞADIKLARINA DAİR DÜŞÜNCELERİ	764
BİLİŞİM TEKNOLOJİLERİ VE YAZILIM DERSİ PROGRAMININ ÖĞRETMEN GÖRÜŞLERİNE GÖRE DEĞERLENDİRİLMESİ (KONYA-EREĞLİ ÖRNEĞİ).....	765
HOW WELL PREPARED MATHEMATICALLY ARE OUR ENGINEERING STUDENTS WHO TRANSFER FROM AN ORDINARY DEGREE INTO AN HONOURS DEGREE	766
AN EVALUATION ABOUT TEACHER TRAINING PROGRAMS: FROM THE PERSPECTIVE OF PRESERVICE TEACHERS	770
EVALUATION OF ALGORITHM IMPLEMENTATION ASSESSMENT METHODS BASED ON A DATA STRUCTURE COURSE	776
DİGİTAL BOŞLUK: KIRSAL ALANLARDA GÖREV YAPAN SINIF ÖĞRETMENLERİNİN BİLGİ İLETİŞİM TEKNOLOJİLERİNİN KULLANIMINA İLİŞKİN GÖRÜŞLERİ.....	781
LİSE ÖĞRENCİLERİNİN “AKILLI TAHTA” KAVRAMINA İLİŞKİN METAFORLARI.....	783
CORRELATIONS AMONG ASSESSMENT TECHNIQUES USED IN AN INTRODUCTORY PROGRAMMING COURSE	793
PRESERVICE PRIMARY MATHEMATICS TEACHERS' VIEWS.....	798
FARKLI ÖĞRENME STİLLERİNİN FEN BİLGİSİ ÖĞRETMEN ADAYLARINDA PROJE PERFORMANSI VE AKADEMİK BAŞARIYA ETKİSİNİN İNCELENMESİ	803
THE EXPLORATION OF QUICK POLLS QUESTIONS' LEVELS WITH THE BLOOM'S TAXONOMY: A CASE STUDY.....	809
CONTINUING TEACHER EDUCATION COURSES OF COMPUTATIONAL RESOURCES IN THE TEACHING OF MATHEMATICS AND PHYSICS: CREATION, APPLICATION AND STUDY.....	810
A PROBLEM GENERATOR SYSTEM TO LEARN FIRST-DEGREE EQUATIONS.....	814
MATHEMATICS TEACHERS' VIEWS ABOUT TEACHING GENERALIZATION OF NUMBER PATTERNS	819

OTOMOTİV SEKTÖRÜNDE YENİ TEKNOLOJİLER İÇİN ÇOK BOYUTLU EĞİTİM-ÖĞRETİM PLATFORMU	824
ÜNİVERSİTELER İLE EĞİTİME İLİŞKİN SÜRDÜRÜLEN İŞBİRLİKLERİNİN FİRMALARIN ÖZÜMSEME KAPASİTESİNE ETKİSİ	832
THE LIFE AND SCIENTIFIC METHODS OF MEHMED TAHİR FROM BURSA	842
ÖĞRENME STİLLERİ, MATEMATİK KAYGISI, MATEMATİK ÇALIŞMA SÜRESİ VE MATEMATİK BAŞARISI ARASINDAKİ AÇIKLAYICI VE YORDAYICI İLİŞKİLER	846
CENTRAL HOSPITAL APPOINTMENT SYSTEM (CHAS-MHRS).....	847
ON COMPLETION IN PSEUDO-QUASI-N-NORMED SPACE.....	848
RATES ASSOCIATED PROBLEM-SOLVING ABILITY WITH PROGRAMMING IN COMPUTER STUDENTS	853
PROJE TABANLI ÖĞRENME YAKLAŞIMININ ÜSTBİLİŞSEL FARKINDALIĞA ETKİSİ İLE İLGİLİ ÖĞRENCİ GÖRÜŞLERİ.....	858
CONTEXTUALIZED LEARNING SETTINGS FOR MEANINGFUL NATURE OF SCIENCE UNDERSTANDING	863
THE INFLUENCE OF INITIAL TEACHER TRAINING IN FUTURE TEACHERS' PERCEPTIONS ABOUT MATHEMATICS TEACHING AND LEARNING	864
SINIF ÖĞRETMENİ ADAYLARININ UZUNLUK ÖLÇME KONUSUNDA ÖĞRENCİLERİN KAVRAM YANILGISILARINI TESPİT ETME DURUMLARI	869
EXAMINING THE CONCEPT CARTOONS BY PRE-SERVICE PRIMARY SCHOOL TEACHERS	874
THE EFFECT OF INFORMATION TECHNOLOGY IN TEACHING PHYSICS COURSES	879
MADDENİN PARÇACIKLI YAPISI İLE İLGİLİ KAVRAM YANILGILARININ GİDERİLMESİNDE MODELE DAYALI AKTİVİTELERİN ETKİSİ.....	884
BECERİ TEMELLİ ELEŞTİREL DÜŞÜNME EĞİTİMİNİN İLKOKUL 3. VE 4. SINIF ÖĞRENCİLERİNİN ELEŞTİREL DÜŞÜNME BECERİLERİNİ GELİŞTİRME DÜZEYİNE ETKİSİ	885
ÜNİVERSİTE ÖĞRENCİLERİNİN MEDYA OKURYAZARLIK DÜZEYLERİ.....	894
ÖĞRETMENLERİN RUTİN OLMAYAN MATEMATİKSEL PROBLEMLERİ ÇÖZMEDE KULLANDIKLARI STRATEJİLER	895
EXPLORING THE RESULT OF THALES THEOREM AND ITS RELATIONSHIP TO OTHER SHAPES AMONG IRANIAN MATHEMATIC HIGH SCHOOL STUDENTS.....	902
SOLVING A GEOMETRICAL EXERCISE FROM FOUR PERSPECTIVE.....	907
A SOFTWARE SIMULATION FOR MULTI-CHANNELS WDM BY HYBRID EDFA/RA SYSTEM	911
İLKÖĞRETİM MATEMATİK ÖĞRETMEN ADAYLARININ MATEMATİK TARİHİNİN MATEMATİK EĞİTİMİNDE KULLANILMASINA YÖNELİK TUTUM VE İNANÇLARI.....	918
MESLEK YÜKSEKOKULLARINDA ÖĞRENCİLERİN MATEMATİK BAŞARI SIRASI İLE GENEL BAŞARI SIRALAMASININ İNCELENMESİ.....	925
MATHEMATICS ACTIVITIES OF PEOPLE AT DIFFERENT LEVEL	930
ORTAOKUL 5.SINIF FEN BİLİMLERİ DERSİ ETKİNLİKLERİNİN LABORATUVAR KULLANIM TEKNİKLERİ VE KAZANIMLARA UYGUNLUĞU AÇISINDAN İNCELENMESİ.....	931
ABOUT 8 th GRADE STUDENTS' SKILLS IN TRANSLATING AMONG MULTIPLE REPRESENTATIONS	941
AŞKIN SAYILAR ŞADIRVANI.....	942
MOODLE ÖĞRENME YÖNETİM SİSTEMİNİN KULLANILABİLİRLİĞİNİN İNCELENMESİ.....	943

2005 VE 2013 FEN BİLGİSİ ÖĞRETİM PROGRAMLARININ 4. VE 5. SINIF DÜZEYLERİNİN BİLİMSEL SÜREÇ BECERİLERİ AÇISINDAN KARŞILAŞTIRILMASI.....	949
LİSANSÜSTÜ ÖĞRENCİLERİNİN YENİ FEN BİLİMLERİ ÖĞRETİM PROGRAMINA İLİŞKİN GÖRÜŞLERİ.....	950
İLKÖĞRETİM 5. SINIF FEN BİLİMLERİ DERS KİTABI İÇERİĞİNE ELEŞTİREL BAKIŞ.....	955
8. SINIF ÖĞRENCİLERİNİN GEOMETRİK CİSİM İLE İLGİLİ KAVRAM İMGELERİ.....	956
TEACHER VIEWS ON STUDENTS' MISTAKES AND MISCONCEPTIONS: EQUATION EXAMPLE	957
ON DAILY MATHEMATICS: MATHEMATICS COMING FROM MINUS INFINITE.....	958
DYSLEXIA AND DIFFICULTIES IN MATHEMATICS.....	959
6. SINIF MATEMATİK DERSİNDE PROBLEME DAYALI ÖĞRENME YAKLAŞIMININ MATEMATİĞE İLİŞKİN TUTUMA ETKİSİ.....	960
8. SINIF ÖĞRENCİLERİNİN PERSPEKTİF ÇİZİMLER KONUSUNU ÖĞRENMELERİNE WEBQUEST UYGULAMASININ ETKİSİ.....	964
SOCIAL WORK AND ICT-SOME ETHICAL ISSUES.....	965
SEVERAL VIEWS OF TEACHING PHYSICS.....	969
THE PHENOMENON OF CYBER BULLYING IN ALBANIAN CONTEXT: AN EXPLORATIVE STUDY OF STUDENTS' PERCEPTIONS.....	976
CATEGORIZING MATHEMATICS KNOWLEDGE TO USE ICT IN MATHEMATICS EDUCATION	980
MATHEMATICS TEACHER CANDIDATES'.....	989
FATİH PROJESİ İL KOORDİNATÖRLERİ VE EĞİTMENLERİNİN, FATİH PROJESİ KAPSAMINDA VERİLEN EĞİTMEN EĞİTİMLERİNE İLİŞKİN GÖRÜŞLERİ.....	999
SELF-CONCEPT AND SELF-EVALUATION IN THE TRANSITION FROM PRIMARY TO LOWER SECONDARY EDUCATION.....	1007
ASSESSING THE CLIMATE FOR CREATIVITY IN MATHEMATIC'S LESSONS.....	1014
SINIF ÖĞRETMENİ ADAYLARININ ÇOKLU TEMSİLERİ KULLANIM SÜREÇLERİ.....	1021
MÜHENDİSLİK ÖĞRENCİLERİNİN İRRASYONEL SAYI BİLGİLERİ.....	1027
ORTAOKUL ÖĞRENCİLERİNİN MATEMATİK TERİMLERİNİ SÖZEL VE MATEMATİKSEL TEMSİL BECERİLERİ.....	1028
FEN BİLGİSİ VE SINIF ÖĞRETMENLERİNİN FEN KAVRAM ÖĞRETİMLERİ, KAVRAM YANILGILARINI SAPTAMA VE GİDERME ÇALIŞMALARININ DEĞERLENDİRİLMESİ.....	1037
ÖĞRETMEN ADAYLARININ YAŞAM BOYU ÖĞRENME EĞİLİMLERİNİN ÇEŞİTLİ DEĞİŞKENLER AÇISINDAN İNCELENMESİ.....	1038
IMPACT OF EXPLICIT-REFLECTIVE AND HISTORY BASED INSTRUCTION ON PRESERVICE SCIENCE TEACHERS' UNDERSTANDING OF NATURE OF SCIENCE.....	1040
BİR PROBLEMİ BEŞ FARKLI YOLDAN ÇÖZMEK, BEŞ PROBLEMİ BİR YOLDAN ÇÖZMEKTEN DAHA MI İYİDİR?.....	1041
<i>f</i> -CEBİRLERİNDE SIRALI İDEALLER.....	1046
THE PERCEPTIONS OF THE PRE-SERVICE SCIENCE TEACHERS' PROBLEM-SOLVING SKILLS	1050
7. SINIF “İNSAN VE ÇEVRE” ÜNİTESİNE YÖNELİK BİR EĞİTSEL OYUN GELİŞTİRİLMESİ ve UYGULANABİLİRLİĞİNİN ARAŞTIRILMASI.....	1051
ÖĞRETMEN ADAYLARININ KAVRAM KARİKATÜRLERİNE İLİŞKİN GÖRÜŞLERİ.....	1056
İLKÖĞRETİM MATEMATİK ÖĞRETMENLİĞİ ÖĞRENCİLERİNİN SİLİNDİR KAVRAMINA DAİR KAVRAM İMAJLARININ İNCELENMESİ.....	1061

BİR KAMPÜS AĞINDA EN KISA UZUNLUKLU HAMILTON ÇEVRELERİN BULUNMASI.....	1067
PSEUDOSCIENTIFIC BELIEFS OF UNIVERSITY SCIENCE EDUCATION STUDENTS.....	1072
THE EFFECTS OF MODEL BASED TEACHING ON 8 th GRADERS' METACOGNITIVE AWARENESS AND ATTITUDES TOWARDS SCIENCE AND TECHNOLOGY COURSE: EXAMPLE OF SOUND UNIT	1073
STUDENTS' INTERNET AND WEB 2.0 USE: A CASE OF BURDUR'S MIDDLE SCHOOLS	1074
FEN VE MATEMATİK ÖĞRETMEN ADAYLARININ “EŞİTLİK, EŞİTSİZLİK, DENKLİK, DENKLEM, ÖZDEŞLİK” KAVRAMLARINA İLİŞKİN ALGILARI.....	1079
THE INVESTIGATION OF PRESERVICE TEACHERS' MEDIA AND TECHNOLOGY USAGE AND ATTITUDES	1080
KESİRLER KONUSUNDAKİ KAVRAM YANILGILARI İLE İLGİLİ ÖĞRETMEN VE ÖĞRENCİLERDEN YANSIMALAR	1081
VERİ MADENCİLİĞİ İLE 7.SINIF ÖĞRENCİLERİNİN SAYILAR ÖĞRENME ALANINDAKİ PROBLEM ÇÖZME STRATEJİLERİNİN İNCELENMESİ	1086
ORTAÖĞRETİM ÖĞRENCİLERİNİN KUVVET VE HAREKET KONUSUNDAKİ KAVRAM İMAJLARI.....	1087
MATEMATİK ÖĞRETMEN ADAYLARININ MATEMATİKSEL KANIT YAPMAYA YÖNELİK GÖRÜŞLERİ.....	1088
PRESERVICE SCIENCE TEACHERS' PERCEPTIONS OF GENETICALLY MODIFIED ORGANISMS: A METAPHOR ANALYSIS	1089
INTERACTIVE E-LEARNING MATERIALS PRODUCTION AND SAMPLE APPLICATIONS IN THE FIELD OF MATHEMATICS	1090
SINIF ÖĞRETMENLERİNİN MATEMATİK KAYGISI.....	1091
PRESERVICE SCIENCE TEACHERS' PERCEPTIONS OF GENETICALLY MODIFIED ORGANISMS: A METAPHOR ANALYSIS	1092
İKİ AŞAMALI ÇOKTAN SEÇMELİ TEST KULLANILARAK ÖĞRENCİLERİN “MADDENİN TANECİKLİ YAPISI” ÜNİTESİ İLE İLGİLİ ALTERNATİF KAVRAMALARININ BELİRLENMESİ.....	1093
MADDENİN TANECİKLİ YAPISI İLE İLGİLİ ANLAMALARIN BELİRLENMESİNDE TAHMİN-GÖZLEM-AÇIKLAMA YÖNTEMİNİN VE ÇALIŞMA YAPRAKLARININ KULLANIMI	1099
ÖĞRENCİLERİN FONKSİYON KAVRAMINA İLİŞKİN KAVRAM YANILGILARINA YÖNELİK ÖĞRETMEN YAKLAŞIMLARI.....	1105
İLKOKUL 1. SINIF ÖĞRENCİLERİNİN DRAMA TEMELLİ ÖĞRETİM İLE TOPLAMA İŞLEMİ İLE İLGİLİ ÖĞRENME SÜREÇLERİNİN İNCELENMESİ.....	1107
MATEMATİKTE ÜSTÜN ZEKÂ VE ÜSTÜN YETENEK KAVRAMLARI ÜZERİNE ALAN YAZIN İNCELEMESİ.....	1109
7. SINIF ÖĞRENCİLERİNİN KESİRLERDE SIRALAMA KONUSUNDAKİ KAVRAM YANILGILARI	1110
THE IMPORTANCE OF LIFELONG LEARNING FOR TURKEY AND EU RELATIONSHIP IN THE GLOBAL AND CHANGING WORLD.....	1112
9-12. SINIF BİYOLOJİ DERSLERİNDE BİLİM İNSANLARINDAN YARARLANMA	1117
UYARLANMIŞ BİRİNCİL LİTERATÜRE DAYALI YÖNTEMİN BİYOLOJİ ÖĞRETMEN ADAYLARININ BİLİM İNSANI İMAJLARI ÜZERİNE ETKİSİ.....	1118
STUDENTS' OPINIONS ABOUT THE ACTIVITIES BASED ON CONCEPTUAL CHANGE STRATEGIES	1119

BİYOLOJİ ÖĞRETMEN ADAYLARININ ORGAN NAKLİ VE BAĞIŞI KONUSUNA BAKIŞ AÇILARININ BELİRLENMESİ VE DEĞERLENDİRİLMESİ	1120
AKILLI TAHTA KULLANIMININ ÖĞRENCİLERİNİN MATEMATİK VE GEOMETRİ ÖZ- YETERLİLİK DÜZEYLERİNE ETKİSİ	1121
GELECEĞİN SINIF ÖĞRETMENLERİ VE FENİN GÜNLÜK HAYATLARINDAKİ YERİ	1123
MATEMATİK ETKİNLİKLERİ OLUŞTURMAK İÇİN ÖĞRENME YÖNETİM SİSTEMİ KULLANIMINA YÖNELİK ÖNERİLER.....	1124
ÖĞRETMEN ADAYLARININ SABİT FONKSİYONLARIN	1125
KHALİFA UNİVERSİTY OF SCİENCE, TECHNOLOGY AND RESEARCH (KUSTAR) STUDENTS' ATTİTÜDES TOWARDS MATHEMATİCS İN THE LİGHT OF VARİABLES SUCH AS GENDER, NATIONALİTY, MATHEMATİCS SCORES AND THE COURSE THEY ARE ATTENDİNG	1126
FACTORS AFFECTING THE FREQUENCY OF ICT USAGE IN PRIMARY SCHOOLS TEACHING	1144
ÖĞRENCİLERİN PROBLEME DAYALI ÖĞRENME YÖNTEMİNİN UYGULANMASI HAKKINDAKİ DEĞERLENDİRMELERİ	1152
GOLF SPORU YAPAN BİREYLERİN DİKKAT DÜZEYLERİNİN İNCELENMESİ.....	1154
THE ANALYSIS OF THE ATTENTION LEVELS OF INDIVIDUALS PLAYING GOLF	1155
FUTBOL BRANŞINA KATILAN 9-14 YAŞ GRUBU ERKEK ÇOCUKLARIN IŞIK REAKSİYON ZAMANLARININ BELİRLENMESİ.....	1156
DETERMINING THE TIME OF LIGHT REACTION OF THE MALE CHILDREN BETWEEN 9 AND 14 YEARS OLD WHO ATTENDED THE FOOTBALL BRANCH	1157
THE EFFECT OF PRACTICES IN THE LABORATORY COURSE ON THE DEVELOPMENT OF SCIENTIFIC PROCESS SKILLS OF TEACHER CANDİTATES.....	1158
İNQUIRY-BASED LEARNING IN CHINA : LESSON LEARNED FOR SCHOOL SCIENCE PRACTICES.....	1159
APPLICATION OF MATHEMATİCS TO TRANSPORT PHENOMENA	1160
A NEW E-LEARNİNG PARADİGM: TOOLS AND TECHNİQUES.....	1161
POTENTIAL USE OF DIGITAL TECHNOLOGIES IN MATHEMATICAL MODELING THE FIRST STEPS OF RESEARCH.....	1168
EFFECT OF GENDER-RELATED DIFFERENCES IN ACADEMIC ACHIEVEMENT AND RETENTION OF SENIOR SECONDARY SCHOOL STUDENTS TAUGHT GEOMETRY USING PROBLEM SOLVING APPROACH.....	1174
FAILURE IN MATHEMATICS	1179
SINIF ÖĞRETMENLERİNİN FEN VE TEKNOLOJİ ÖĞRETİMİNE YÖNELİK TUTUMLARI.....	1180
PEDAGOJİK ALAN BİLGİSİ BİLEŞENLERİNDEN ÖĞRENCİ DÜŞÜNCE Sİ BİLGİSİNE YÖNELİK BİR LİTERATÜR TARAMASI.....	1181
SERVICE LEARNING IN SCIENCE TEACHER PREPARATION PROGRAM: CONCEPTS AND PRACTICES.....	1183
ORTAÖĞRETİM MATEMATİK ÖĞRETMEN ADAYLARININ ÖĞRENCİLERİNİN HATALI ÇÖZÜMLERİNİ ÖNGÖRME BECERİLERİ.....	1192
BAYES RISK FOR SELECTION THE MEDIAN CATEGORY FROM EVEN SAMPLE SIZE.....	1203
THE IMPACT OF SOCİOCULTURAL DİALECTİCAL METHOD ON STUDENTS' BEHAVİORAL, COGNİTİVE AND EMOTİONAL ENGAGEMENT.....	1213
EXPECTATIONS TOWARDS ADEQUACIES OF NEW IT GRADUATES BASED ON SECTOR AND EXPERIENCE OF THE EMPLOYERS.....	1214

THE USAGE OF SOCIAL MEDIA FOR LEARNING AND TEACHING PURPOSES: AN IMPLEMENTATION OF EXTENDED THEORY OF REASONED ACTION MODEL.....	1219
FEN BİLİMLERİ ÖĞRETMEN ADAYLARININ GİRİŞİMCİ ÖZELLİKLERİNİN BAZI DEĞİŞKENLER AÇISINDAN İNCELENMESİ	1225
ÖĞRENCİLERİN ÖĞRENME YAKLAŞIMLARI İLE DÜŞÜNME STİLLERİ ARASINDAKİ İLİŞKİNİN İNCELENMESİ	1226
EXPLORING PRESERVICE EARLY CHILDHOOD TEACHERS' MATHEMATICS-RELATED EMOTIONS.....	1232
COMPLETENESS IN DISLOCATED QUASI-METRIC SPACE	1233
ORTAOKUL ÖĞRENCİLERİNİN ÇEVRESEL TUTUM, DAVRANIŞ VE DÜŞÜNCELERİNİN DOĞA EĞİTİMİ PROJESİNE BAĞLI DEĞİŞİMİ	1237
FİZİK ÖĞRETMEN ADAYLARININ ÖĞRETMENİN VE ÖĞRENCİNİN ROLÜ AÇISINDAN EĞİTİM SÜRECİNE İLİŞKİN FELSEFİ GÖRÜŞLERİNİN İNCELENMESİ	1242
FİZİK ÖĞRETMEN ADAYLARININ ÖĞRENME STİLLERİNİN ÇEŞİTLİ DEĞİŞKENLER AÇISINDAN İNCELENMESİ.....	1243
iOS PLATFORMU İÇİN TIBBİ ETKİNLİK VE KONGRE UYGULAMASI	1244
BİLİM İÇİN BİR BULUŞMA NOKTASI:	1248
FEN BİLGİSİ ÖĞRETMEN ADAYLARININ ORGANİK BİLEŞİKLERİ IUPAC SİSTEMİNE GÖRE ADLANDIRMADA KARŞILAŞTIĞI ZORLUKLAR.....	1249
TEACHING AND LEARNING IN HIGHER EDUCATION.....	1250
DİNAMİK GEOMETRİ YAZILIMI GEOGEBRA'NIN KULLANIMININ ÖĞRENCİ BAŞARISI VE KALICILIK ÜZERİNDEKİ ETKİSİ ¹	1256
KAVRAMSAL DEĞİŞİM METİNLERİNİN MADDENİN AYIRT EDİCİ ÖZELLİKLERİNİ ANLAMAYA ETKİSİ	1257
MAKİNE ÖĞRENMESİ ALGORİTMALARI KULLANILARAK KALP HASTALIĞI TESPİTİ.....	1258
LİSE ÖĞRENCİLERİNİN MATEMATİK DERSİNİ NİYE SEVMEDİKLERİ ÜZERİNE BİR ARAŞTIRMA.....	1263
KNOWLEDGE OF CURRICULUM OBJECTİVES AND POSSESSİON OF THE SUBJECT – NECESSİTY FOR ALBANİAN LANGUAGE ACQUISİTION FROM STUDENTS	1270
6-7-8. SINIF MATEMATİK DERSİ ÖĞRETİM PROGRAMINDA YER ALAN ARA DİSİPLİNLERE YÖNELİK ÖĞRETMEN GÖRÜŞLERİ	1271
HARMANLANMIŞ ÖĞRENME ALANINDA TÜRKİYE'DE YAPILMIŞ YÜKSEK LİSANS VE DOKTORA TEZLERİNİN İNCELENMESİ	1276
PROSPECTIVE MIDDLE SCHOOL MATHEMATICS TEACHERS' COMPUTATIONAL ESTIMATION STRATEGIES FOR ADDITION.....	1282
INVESTIGATING MASTER THESIS AND DOCTORAL DISSERTATIONS ABOUT NATURE OF SCIENCE: TURKEY SAMPLE.....	1283
ÖĞRENCİLERİN MOBİL TEKNOLOJİLERE İLİŞKİN ÖN BİLGİ DÜZEYLERİNİN FARKLI DEĞİŞKENLER AÇISINDAN İNCELENMESİ	1284
EVALUATING EFFECTS OF AN EXHIBITION VISIT ON PRE-SERVICE ELEMENTARY TEACHERS' UNDERSTANDINGS ON CLIMATE CHANGE	1290
UZAKTAN EĞİTİMDE ÇEVİRİMİÇİ DERS İÇİN BİR YOKLAMA SİSTEMİNİN TASARIMI	1298
ÖĞRETMEN ADAYLARININ MATEMATİK ÖĞRETİMİNDE KENDİLERİNE REHBER EDİNDİKLERİ ÖĞRETİM MODELLERİ.....	1302
ASSESSING STUDENT LEARNING OUTCOMES THROUGH TECHNOLOGY	1303

ÖĞRETMENLERİN TEKNOLOJİK PEDAGOJİK ALAN BİLGİLERİNİN İNCELENMESİ	1304
AZERBAJCAN VE TÜRKİYE’DE OKUTULAN 1.SINIF MATEMATİK DERS KİTAPLARININ İÇERİK AÇISINDAN KARŞILAŞTIRILMASI.....	1310
EĞİTSEL OYUNLARLA MATEMATİK ÖĞRETİMİ DERSİNDE TASARLANAN OYUNLARIN ANALİZİ	1311
SPATIAL SKILLS AS PREDICTORS OF SUCCESS IN MATHEMATICS	1312
GÖRÜNTÜ PARAMETRELERİNİN PARÇACIK SÜRÜ OPTİMİZASYONU YÖNTEMİ İLE ENİYİLEMESİ	1313
TURKISH AND ISLAMIC SCIENTISTS IN TURKISH SCIENCE TEXTBOOKS	1318
BİLGİSAYAR DESTEKLİ ÖĞRETİMİN LİNEER BAĞIMSIZLIK KONUSUNDA AKADEMİK BAŞARI ÜZERİNE ETKİSİ	1319
LİSE ÖĞRENCİLERİNİN MATEMATİK DERSİNDE ÖĞRENME STİLLERİNE GÖRE UYGULANAN ETKİNLİK TÜRLERİNE YÖNELİK TERCİHLERİ	1320
AN ANALYSIS OF NUMBER SENSE OF THE HIGH-ACHIEVING HIGH SCHOOL STUDENTS	1326
ODAK GRUP GÖRÜŞMESİ İLE KÜTLE VE AĞIRLIK KAVRAMLARININ ÖĞRETİMİ.....	1327
FEN VE TEKNOLOJİ ÖĞRETMENLERİN TEKNOLOJİ DOĞASI HAKKINDAKİ DÜŞÜNCELERİ	1328
BİLGİSAYAR MÜHENDİSLİĞİNE GİRİŞ DERSİNE İLİŞKİN ÖĞRENCİ GÖRÜŞLERİNİN DEĞERLENDİRİLMESİ	1329
ÖĞRETMENLİK UYGULAMASINDA GÖREV ALAN UYGULAMA ÖĞRETMENLERİNİN FEN VE TEKNOLOJİ ÖĞRETMEN ADAYLARININ YAPISALCI ÖĞRENME KURAMINA KARŞI TUTUMLARI ÜZERİNE ETKİSİ	1335
IŞIK KİRLİLİĞİNE İLİŞKİN BİLGİSAYAR DESTEKLİ KAVRAM KARİKATÜRLERİNİN GELİŞTİRİLMESİ	1343
CONCEPTUALIZATION OF PEDAGOGICAL CONTENT KNOWLEDGE (PCK) FOR TEACHING MATHEMATICS IN UNIVERSITY LEVEL	1344
ORTAOKUL 7. SINIF ÖĞRENCİLERİNİN ATOM KAVRAMI HAKKINDAKİ KAVRAM YANILGILARI	1349
ORTAOKUL 7. VE 8. SINIF ÖĞRENCİLERİNİN RASYONEL SAYILAR KONUSUNDAKİ YANLIŞ ANLAMALARI VE KAVRAM YANILGILARI.....	1350
SELF-CONCEPT AND SELF-EVALUATION IN THE TRANSITION FROM PRIMARY TO LOWER SECONDARY EDUCATION.....	1351
PERFORMANS ÖLÇÜMÜNDE KULLANILABİLECEK PROBLEM ÖRNEKLEMELERİ VE ÖĞRENCİLERİN BU PROBLEMLERİ ÇÖZÜM SÜREÇLERİNİN İNCELENMESİ.....	1361
AÇILARI VE KENARLARI DİZİ OLUŞTURAN ÜÇGENLER İLE $x^2 + 3y^2 = z^2$ DİOPHANTİNE DENKLEMİ ARASINDAKİ İLİŞKİ ÜZERİNE ¹	1375
HERON ÜÇGENLERİNİN TEĞETLER ÇEMBERLERİNİN YARIÇAPLARI İLE $x^2 + 2y^2 = z^2$ DİOPHANTİNE DENKLEMİ ARASINDAKİ İLİŞKİLER ÜZERİNE ¹	1389
ORTAOKUL BEŞİNCİ SINIF ÖĞRENCİLERİNİN	1399
TEACHING THE SCIENTIFIC EXPLAINING CONCEPT THROUGH “SOCIO-CULTURAL DIALECTIC METHOD” IN SCIENCE COURSES.....	1404
ÜÇ AŞAMALI YÜZME-BATMA TANI TESTİNİN GELİŞTİRİLMESİ	1405
BAYES RISK FOR SELECTION THE MEDIAN CATEGORY FROM EVEN SAMPLE SIZE IN K-NOMIAL DISTRIBUTION.....	1406
LITERATURE ON META-ANALYSIS METHOD.....	1407

ÖZEL GEREKSİNİMLİ BİREYLERİN EĞİTİMİNDE BİLGİ İLETİŞİM TEKNOLOJİLERİNİN KULLANIMI.....	1408
OTİZMLİ BİREYLERİN EĞİTİMİNDE KULLANILAN TABLET UYGULAMALARI	1409
DESIGNING OF A CNC TRAINING SET	1410
THE REVIEW OF THE PERCEPTIONS OF SOCIAL SCIENCES TEACHERS ON TECHNOLOGY INTEGRATION	1419
THE OPINIONS OF THE SOCIAL SCIENCES TEACHERS ABOUT FATİH PROJECT	1420

USING COMPUTER AND ICT EQUIPMENT FOR E-TEACHING AND E-LEARNING: ISSUES AND CHALLENGES FACING TEACHERS

Simin GHAVIFEKR

Faculty of Education, University of Malaya, MALAYSIA

drsimin@um.edu.my

Ahmad Zabidi ABD RAZAK

Faculty of Education, University of Malaya, MALAYSIA

Mohammed Sani IBRAHIM

Faculty of Education, University of Malaya, MALAYSIA

ABSTRACT: Integration of computer and Information Communication Technology (ICT) in education has changed the conventional method of “Chalk and Talk” to “e-Learning and e-Teaching”. While ICT equipment has provided opportunities in open access to a wide variety of digitalized teaching- learning materials as well as speeding up communication and sharing of views among educators, it is yet to reach the desired level due to the current issues and challenges. This study analyses the challenges and issues faced by teachers in public primary schools while using computer and ICT-based teaching equipment in their daily classes. Three hundred (300) teachers in public primary schools in Kuala Selangor district of Selangor, Malaysia, were used as the sample for this study. A self-developed questionnaire which contains 4 different sections including (1) Background of Respondents, (2) The level of computer skills and use of ICT, (3) Barriers on the Use of Computers and ICT, and (4) Suggestion to overcome the barriers was used for data collection. Descriptive statistic and correlation analysis were used for data analysis. The findings indicate that computer and ICT operating skills of the teachers are still in satisfactory stage. Teachers tend to use computer and ICT for their own use rather than uses for teaching and learning process. Time, attitude, training and facilities were found to be among the main influential factors in ICT usage by the teachers. Suggestions to overcome the issues and challenges had been also included in this study that is significant in educational management especially managing ICT in schools.

Keywords: ICT integration, E-teaching & E-learning, Primary education

INTRODUCTION

Nowadays, Information and Communication Technology (ICT) has become an important part of the most organizations including those in education. ICT refers to the study on use of computers, the Internet, video, and other technologies as a subject in schools (Oxford Advanced Learner’s Dictionary). The term “ICT” was first introduced to education system over two decades ago and since then its rapid growth has become one of the most important topic discussed by scholars. This is due to the potential of ICT to support education and create opportunities to enhance the quality of teaching and learning outcomes (Bingimlas, 2009; Hussain et al., 2011).

Today, ICT literacy is the prerequisite for the 21st century’s appropriate knowledge and skills. This is due to the fact that through ICT, one can explore useful information to be able to overcome the modern life’s obstacles. The rapid global technological advancement and development of ICT has placed traditional teaching and learning to *e-teaching and e-learning*. In this regard, using computer has shift teaching and learning process into a more challenging profession, where teachers are required to integrate ICT in their daily classes instead of using only the traditional teaching-learning methods (Hamidi et al., 2011). Accordingly, e-Teaching and e-Learning techniques are preferably replacing the traditional method of *Chalk and Talk* with the intention to make the teaching and learning environment more interactive and proactive.

The other advantage of ICT integration in education system is to enhance teaching and learning quality and accessibility as well as cost-efficiency of the delivery of education. Moreover, using ICT in education also will help in networking of the learning communities with the aim of being equipped to face the challenges of global competition (Bruniges, 2003, p.1). In addition, the main benefit of the modern technologies is to offer relevant tools and equipment that can be used in daily classrooms to improve teaching–learning process (Lefebvre, Deudelin & Loiselle, 2006).

Integrating ICT in education system does not mean that computer is able to replace the teachers completely, but it means using computer tools, equipment, and applications as an enabler to help the teachers to improve students' learning and better pedagogical practices. In this regard, ICT can be used to deliver information to students in order to help them to complete their learning tasks. If modern technologies integrated with the conventional methods, it will then results in a robust and effective outcome for teaching and learning process. Moreover, learning technologies help students to develop their skills, while boost up their motivation and widen their knowledge (Bransford, Brown & Cocking, 2000; Grabe & Grabe, 2007).

However, as the first stage of formal education, primary level of schooling is important and using ICT in teaching and learning can help students and teachers to develop their competencies that are needed for the global society. This is because "by teaching ICT skills in primary schools, the pupils are prepared to face future developments based on proper understanding" (Grimus, 2000, p.362).

ICT Integration in the Malaysian Education System

During the past decades, there has been a growing interest, attention and investment towards the use of ICT in education system globally. Similarly, the integration of ICT into the education system has been one of the major attempts by the Education Ministry of Malaysia in the recent years. This is because ICT offers new potentials that lead to significant changes in the educational organization. Moreover, promoting new technologies and innovative changes to power national competitiveness is a growing challenge to higher education in Malaysia (Hamidi, 2011; Aida Suraya, 2009; Hussain et al., 2011). Correspondingly, to achieve the country's aspiration of Vision 2020, higher education institutions face the challenge to train and educate "competent, productive and knowledgeable" human resource (Malaysia, 2001, p. 8). This is in order "to transform the nation into a progressive economy capable of "sustaining high economic growth "(p. 7), and "to meet the impact of globalization and peruse "environmentally sustainable development to reinforce long-term growth" (p. 8).

In the previous five-year plan for the year 2006-2010, the new ICT policies have been launched by the Ministry in order to bring technological change to the Malaysian education system (Banjunid, 2001; Puteh & Vicziany, 2004; Suhaimi et al., 2007). These policies were included to ensure ICT accessibility and literacy for all students, prioritizing the ICT's role and function as a teaching and learning tool in education, and ensuring the use of ICT to enhance productivity, effectiveness and efficiency in management system (Ministry of Education, 2006).

Recently, the element of ICT has been included as one of the main transformation shifts in the Malaysia's latest *Education Blueprint* so called 'MEB' for the years 2013-2025 as the national education future development focus. It was first introduced by the Ministry of Education Malaysia on September, 2012. The plan outlines 11 shifts needed to transform the Malaysian education system on par with systems owned by developing countries. The program will be implemented in phases, which will be in 3 phases for a period of 13 years. The program is more on the development of teachers and students in terms of access, quality, equity, solidarity and efficiency.

The transform shift of ICT named as "Leverage ICT to Scale up Quality Learning across Malaysia" emphasizes three aspects:

- i) By 2013, the government aims to establish and provide more internet accessibility in the national schools to create virtual learning environment via education development programme called "1BestariNet" for all 10,000 schools
- ii) Augment online best practices content starting with video library of best teachers delivery lessons in critical subjects in 2013
- iii) Maximize the use of ICT for distance learning and self-paced learning to expand capacity of learning outcome and allow for more customized learning requirements

Under the ICT transform focus (The seventh shift), the MOE is trying to strengthen ICT capacity in different stages to enhance the quality of teaching and learning in the country. Accordingly, the use of ICT among teachers should be optimized so that they can make a difference in the quality of teaching and learning in their schools. This is due to teachers' key role in motivating and encouraging students to utilize ICT in their learning process.

In the first wave of reform, the Ministry reviews the current ratio of teacher-student for ICT devices allocations, ICT innovations on distance learning to determine the best suggestion to give the Malaysian students access to the full spectrum of the curriculum and achieve the best outcome of their learning. While for the second wave of reform, the Ministry of Education will introduce a few ICT education programs to create interactive during teaching and learning process, culturally-relevant content for indigenous students, and improve the accessibility of online quality learning resources for students included those schools which located in remote areas (Education Blueprint, 2013, Chap 4, pp.13-15).

The intention of government is to upgrade the quality of ICT skills among schools especially school in remote area such as Sabah, Sarawak, and Pahang. Furthermore, it also trying to narrow down the gaps of ICT capacities both in terms of quantity and quality between urban, rural and remote area in whole nation. Moreover, it could enhance the quality of teaching and learning once the quality and quantity of ICT capacities being improve. However, the ICT integrating at different stage or wave in education will be the most challenging task undertaking due to the possibility of failure to achieve the learning target. In addition, it would bring a further widening and even serious of the knowledge gap between students in remote areas and developed city and then creates the deepening inequalities in economic and social for the whole nation (Tinio, 2003).

The Malaysian Education Ministry should handle all the computer services as tools, application and information supply. In this new era, ICT applications become necessary in all dealing. Some teachers provided with laptops and some are not. Is this the reason why teachers never using computer in the classroom teaching? Is ICT facilities in schools are used to the maximum? The finding indicates that the use of ICT in schools is not performed optimally and not showing its effectiveness in accordance with the government's education policy. According to a study carried out by the Ministry in 2012, the use of information and communication technology (ICT) in schools is limited. The study also showed that only one third of teachers regularly use ICT in their classrooms (MEB 2013 - 2025, p. 142). Furthermore, about 80% of teachers use ICT less than one hour a week. The research shows that teachers are more interested in using the traditional method of using books in their teaching and learning process. Hence, the ICT facilities in some schools are not used as effectively and efficiently as they should be. Therefore, it is important to analyze the key factors that contributed to this phenomenon in order to overcome the current issues. Therefore, this study aims to identify key issues and challenges that influence in ICT integration among teachers in schools.

Research Objectives

The objective of this study is:

1. To identify teachers level of computer skills and technique in teaching and learning process in classroom.
2. To identify the barriers in using ICT in teaching and learning in classroom.
3. To identify the way to overcome barriers in computer and ICT application among teachers.

Research Questions

Based on the research objectives, below are the research questions of this study:

1. What is level of teachers' computer skills and technique in teaching and learning process in classrooms?
2. What are the barriers in using ICT in teaching and learning in classrooms?
3. What are the ways to overcome barriers in computer and ICT application among teachers?

Besides research question, five selected hypotheses were tested using Bivariate Correlation in SPSS V.21. Below are five hypotheses tested:

The Study Hypothesis

Hypothesis 1: Correlation between the frequency of teacher uses ICT in classrooms and year of employed

Hypothesis 2: Correlation between the frequencies of teacher knows computers and its functions and year of employed

Hypothesis 3: Correlation between the frequency of teacher knows how to repair own computers and year of employed

Hypothesis 4: Correlation between the frequencies of teacher knows how to create teaching aids with computers and year of employed.

Hypothesis 5: Correlation test between the frequency of teacher uses internet for their personal purpose and year of employed.

METHODOLOGY

Research Sample

Majid Konting (2000) defines population as a set of features which shows the specific measurement on a group of individuals or objects. Individual or object which was observed must have minimal one feature in common between others. First task in sampling is to identify and define specifically the sampled population (Azizi et al., 2007). Population of this research consists of 300 teachers that have been selected randomly from the public primary schools in Kuala Selangor district, Malaysia.

Research Instrument

The research instrument that were used in this study were survey questionnaire that has been developed and modified by the researchers based on the factors that ;a) Provide ample time for respondents to answering the question, b)The questionnaire was easy to answer because the answer has been provided and c) Save time, energy and researchers expenses. However, the questionnaire is included four parts as follows:

Part A: Background of respondents (5 items)

In this section the researchers only focused on the demographic variables such as gender, age, race, academic qualification, teaching experience and subject were teaches in schools. Respondents must indicate (✓) in the option they choose. Simple open question should completed by respondents.

Part B: The level of skills and ICT usage (15 items)

For items in sections B, the statement and the question were created is to find out level of skills and the way teachers apply the ICT in teaching and learning process.

Part C: Barriers in using computer and ICT (7 items)

Items related to computer and ICT usage were found in part C, where the respondent will choose the barrier that they face to use the computer and ICT. The options given is generalized and mostly mentioned in most of the researches, particularly in Malaysian context.

Part D: Limitation on the use of computers and ICT/ The suggestions and ways to overcome the issues (7 items)

In this section there are seven questions that need to be filled in by the respondents based on their opinion.

Pilot Study

In this research, a pilot study was conducted on 100 respondents from 5 of the selected schools. Selection of respondent was randomly chosen.

This pilot study was conducted to ensure the instrument for this study (questionnaire) was suitable in term of language and terms that easily can filled by the respondents and the most important was to determine the reliability of the questionnaire. Reliability value of the questionnaire was tested using Cronbach Alpha to show how suitable are the items as a set of questionnaire. Result of the study gives the alpha value 0.91. This shows that the designed questionnaire has the good reliability. According to Rowntree(1981), classifying 0.7 to 1.0 is the best study. This means that the questions can be used for the pilot study.

Data Analysis

Background analysis

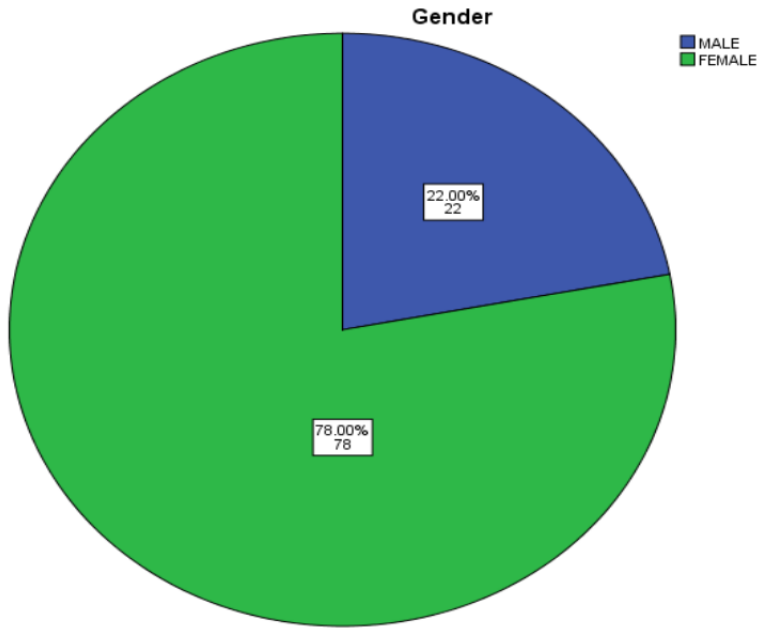

Figure 1. Respondents' Gender Distribution

Figure 1 shows the pie chart of male and female distribution where by 78% of respondents are female and the rest (22%) are male.

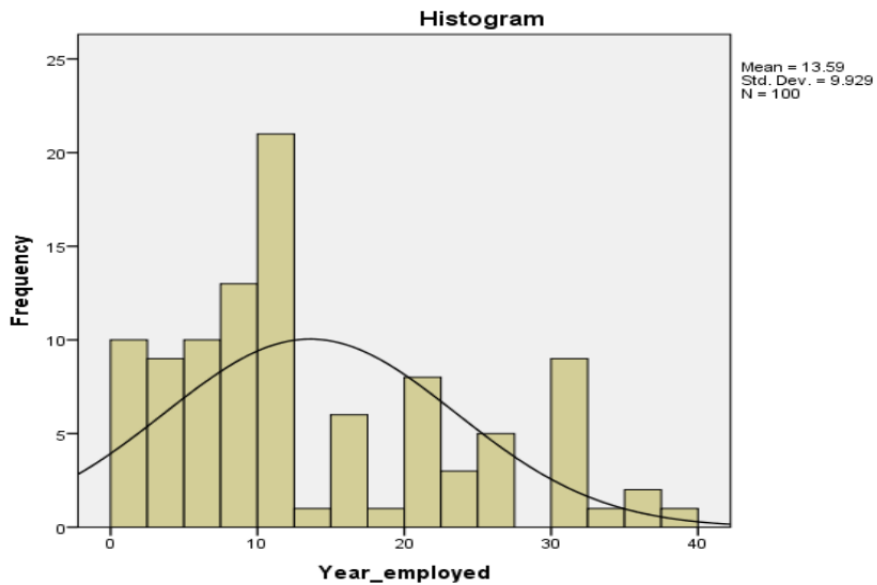

Figure 2. Respondent's Year of Employment

Above histogram shows, most of the samples (about 23%) have 10 to 13 years of experiences, with the mean value of 13.59.

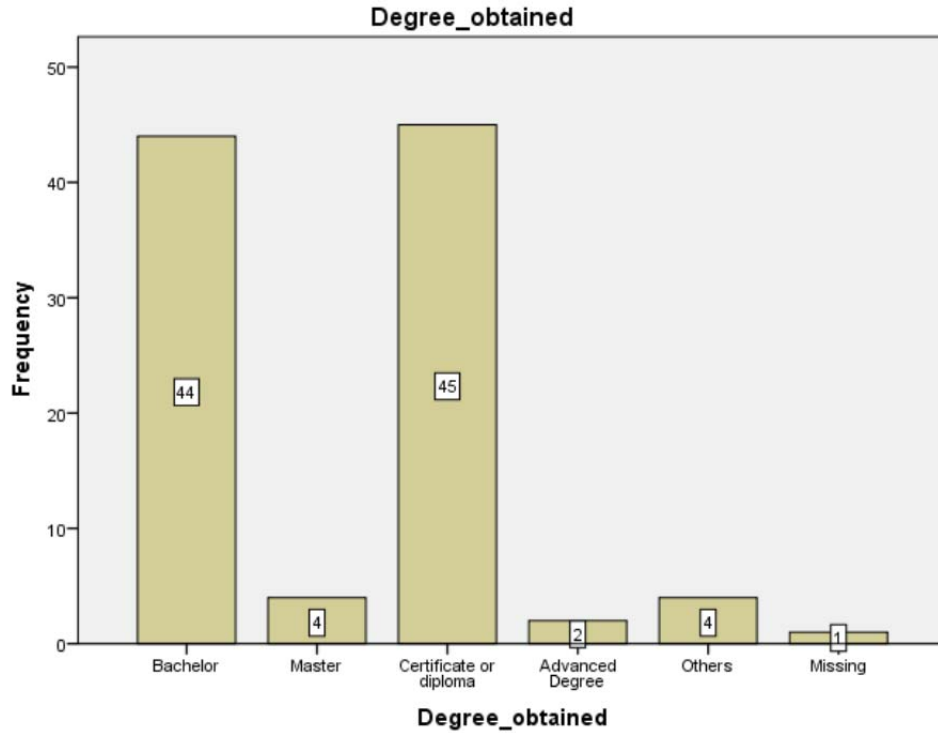

Figure 4. Educational Background of the Respondents

There were more teachers with Bachelors and Certificate or Diploma. There were no PhD holders and Master holders were very rare in schools especially in primary level.

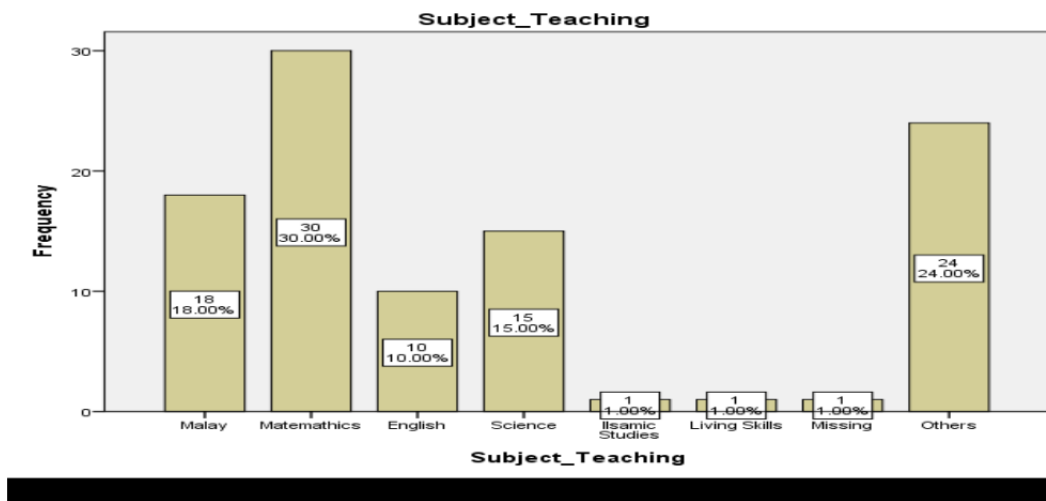

Figure 4. Frequency by Subject Teaching

About 30% of teachers teach Mathematics and only 1% is teaching rare subjects like Islamic studies and Living Skills.

Table 1. Frequency (%) And Mean Table for Skills in Using Computers and ICT

Item	Statement	SD	D	NS	A	SA	Mean
B1	I know computers and its functions	0	1	45	49	5	3.58

B2	I repair my own computer	0	3	48	38	11	3.57
B3	I install software on my own	0	10	23	38	28	3.90
B4	I search teaching aids from internet	3	12	36	37	11	3.47
B5	I use computer to prepare lesson plan	0	7	32	47	14	3.68
B6	I can create teaching aids with computers	3	9	54	29	5	3.24
B7	I can construct a learning web site	3	9	43	39	5	3.40
B8	I prepare notes for my students with internet	4	31	41	22	2	2.87
B9	I find questions for my students from internet	2	14	43	35	6	3.29
B10	I always use computer in my classroom	2	50	39	7	2	3.63
B11	I always look for latest additional information through internet	1	49	40	8	2	3.66
B12	I use internet lively in classroom	1	5	14	63	15	3.98
B13	I use internet in computer lab with my students	3	1	28	51	15	3.86
B14	I teach my students on how to find information in internet	1	1	28	52	14	4.01
B15	I use internet for my personal purpose	0	9	44	35	8	3.66

Note:

1. Strongly Disagree (SD)
2. Disagree (D)
3. Not Sure (NS)
4. Agree (A)
5. Strongly Agree (SA)

Table 1 shows the distribution of respondents by percentage and mean in terms of the frequency and nature use during the process of teaching and learning. Highest mean in the table was 4.01 at item 14 statement in which the majority of respondents agreed that they often teach their students on how to find information in internet for use in teaching and learning in the classroom. The lowest mean is 2.87, for item B8 which means they hardly prepares notes for their students in internet. In addition, a total of 28% of respondents are very sure that they can install their own software. 63% of teachers agree that they use internet lively in their classroom. There are also teachers who say never to use computers for the purpose of teaching and learning which were 50%.

Table 2. Frequency (%) And Mean Table of Obstacles in Using ICT in Classrooms

Item	Problems	SD	D	NS	A	SA	Mean
C1	Hardware and software problems often disrupt lessons	0	1	18	59	21	4.96
C2	Not enough time to use ICT	0	1	20	57	21	4.94
C3	I'm more confident without ICT in classroom	0	3	20	59	17	4.86
C4	Insufficient access to the resources	0	5	25	51	18	4.78
C5	Restricts the content of the lessons	0	5	22	55	17	4.80
C6	ICT makes preparing the lessons more difficult	0	2	19	60	18	4.90
C7	I don't know how to use ICT	0	1	18	59	21	4.96

Table 2 shows Frequency (%) and mean for obstacles in using ICT in classrooms. All the respondents agreed that there are problems faced by them in using ICT in classes, which can be known with zero indicator in SD column. More than 50% are agree with all the problem or obstacles faced by teachers in classroom. This can be shown with all the mean is above 4.00. 60% of the teachers felt that ICT makes preparing the lessons more difficult.

Table 3. Frequency (%) And Mean Table of How to Overcome the Obstacles

Item	Method	SD	D	NS	A	SA	Mean
D1	Create a special fund for the provision of ICT infrastructure for the teacher.	0	2	53	39	6	3.49
D2	Held information technology courses for teachers.	0	4	54	36	6	3.44
D3	Teachers must be ready to accept the changes the paradigm shift to the use of ICT in T&L.	0	3	39	37	21	3.76
D4	Providing incentives and rewards to teachers who are creative and dynamic.	0	6	45	35	14	3.57
D5	To place an ICT expert in each school	0	6	45	38	11	3.34
D6	CDs and Software for more subjects	0	12	53	26	9	3.32
D7	Counselling for teachers	0	13	49	33	5	3.30

Table 3 shows frequency (%) and mean for how to overcome the obstacles mentioned above. All the teachers are agree with all the overcoming options as no one has ticked ‘Strongly Disagree’. However, most of them are not sure about the efficiency of recommended options, as we can see the ‘NS’ ticked by 54 teachers in item D1. The mean 3.76 indicates that teachers must be ready to accept the changes the paradigm shift to the use of ICT in T&L. Counseling for teachers is least preferred by teachers with the lowest mean (3.30).

Testing Hypothesis

Table 4 (Hypothesis 1). Correlation Test between the Frequency of Teacher Uses ICT in Classrooms and Year of Employed

Correlations		B10	Year employed
B10	Pearson Correlation	1	-.097
	Sig. (2-tailed)		.338
	N	300	300
Year_employed	Pearson Correlation	-.097	1
	Sig. (2-tailed)	.338	
	N	300	300

There was a significant correlation between the frequency of teacher uses ICT in classrooms and year of employed, $r = -.097$, $n = 300$, $p > .01$, two tails. Negative correlation (not strongly correlated) shows, less experienced teachers uses ICT more frequently in their classroom.

Table 5 (Hypothesis 2). Correlation Test Between the Frequencies of Teacher Knows Computers and Its Functions and Year of Employed

Correlations		Year employed	B1
Year_employed	Pearson Correlation	1	-.030
	Sig. (2-tailed)		.764
	N	300	300

B1	Pearson Correlation	-.030	1
	Sig. (2-tailed)	.764	
	N	300	300

There was a significant correlation between the frequency of teacher knows computers and its functions and year of employed, $r = -.030$, $n = 300$, $p > .01$, two tails. Negative correlation (not strongly correlated) shows, less experienced teachers knows better about computers.

Table 6 (Hypothesis 3). Correlation Test Between the Frequency of Teacher Knows How to Repair Own Computers and Year Of Employed

Correlations

		Year employed	B2
Year_employed	Pearson Correlation	1	-.079
	Sig. (2-tailed)		.435
	N	300	300
B2	Pearson Correlation	-.079	1
	Sig. (2-tailed)	.435	
	N	300	300

There was a significant correlation between the frequency of teacher knows how to repair own computers and year of employed, $r = -.079$, $n = 300$, $p > .01$, two tails. Negative correlation (not strongly correlated) shows, less experienced teachers highly repairs computers.

Table 7 (Hypothesis 4). Correlation Test between the Frequencies of Teacher Knows How to Create Teaching Aids with Computers and Year of Employed

Correlations

		Year employed	B6
Year_employed	Pearson Correlation	1	-.084
	Sig. (2-tailed)		.404
	N	300	300
B6	Pearson Correlation	-.084	1
	Sig. (2-tailed)	.404	
	N	300	300

There was a significant correlation between the frequency of teacher knows how to create teaching aids with computers and year of employed, $r = -.084$, $n = 300$, $p > .01$, two tails. Negative correlation (not strongly correlated) shows, less experienced teachers uses more computers to prepare teaching aids.

Table 8 (Hypothesis 5). Correlation Test between the Frequency of Teacher Uses Internet for Their Personal Purpose and Year of Employed

Correlations

		Year employed	B15
Year_employed	Pearson Correlation	1	-.102
	Sig. (2-tailed)		.315
	N	300	300
B15	Pearson Correlation	-.102	1
	Sig. (2-tailed)	.315	
	N	300	300

There was a significant correlation between the frequency of teacher uses internet for their personal purpose and year of employed, $r = -.102$, $n = 300$, $p > .01$, two tails. Negative correlation (moderate correlated) shows, less experienced teachers are using internet for their own purpose.

DISCUSSION AND RECOMMENDATION

In the recent years, using computer and ICTs tools and applications in schools have brought many positive impact in teaching and learning processes (Hussain & et al., 2011). Hence, ICT integration has become the core of teaching and learning in the 21st century as e-teaching and e-learning (Lloyd, 2005). Specifically, integration of ICT in primary school teaching and learning is inevitable that the full advantage of ICT and its great potential to enhance teachers' teaching quality and students' learning achievement should be considered.

The results of this study indicates that although in some schools teachers are using ICT in their classrooms, but there is no doubt that still many teachers who are working in rural schools does not have inhale of skills and knowledge on ICT. Hence they are using less computer and ICT application in their classroom, although, they have computer infrastructure in their schools. These findings is similar with the result of a study by Shelly (2004), on the relationship between use of computer application and ICT skills.

In line with previous research (Anderson , 2010; Bovee, Voogt, & Meelisen, 2007; Rosnaini et al., 2008) this study has emphasis on the importance of skills for teachers to apply computer and ICT in their teaching and learning. In this regard, teachers should take initiatives to enhance their computer and ICT skills. The result of this study shows that while the form of computer application among teachers is in the moderate level, application of computer and ICT in teaching and learning to communicate with students is in the low level. It means that teachers are more tend to use computer to prepare paper works and examination questions, analyzing students' achievement and make notes preparation rather than using it for teaching purposes. Meanwhile, internet usage among teachers to get teaching resources is also in low level. Researchers feel that teachers must master various form of computer and ICT application due to nowadays education system experiencing various technological developments. This idea was supported by Peeraer & Van Petegem (2012) that suggested utilizing ICT in education can help teachers to collect, store, process, distribute and disseminate information faster. This will result in time and cost effectiveness of teaching and learning process.

To increase the use of ICT in schools the Ministry and the school management can perform various steps. One of them is to change the teacher's perception and mentality by providing counseling and lectures. Changes in attitudes and values of teachers needed in the face of new challenges in education (Ambigapathy & Shanthi, 2010b). Principals as school leaders should continue to monitor teaching and learning to ensure that teachers use ICT daily. The school management can also take the initiative to provide teachers with intensive use of ICT in their learning.

Also, the use of ICT in schools can be enhanced by improving the existing infrastructure. It can be done by improving ICT infrastructure, replacing new equipment and ongoing maintenance. The school management should also put ICT infrastructure in a safe place so that teachers ensure the safety of consumers. The management of the District Education Office (DEO) needs to frequently monitor the usability of ICT infrastructure to be repaired or replaced easily. Sometimes the DEO should be ready to provide new infrastructure if the ICT infrastructure in schools has become obsolete and is no longer safe to use.

ICT use can be improved by ensuring that all teachers and officers of ICT are literate. According to Brosnan (2001), if the teachers do not develop basic ICT skills and willingness to experience with ICT is not worth it. Thus, the Ministry of Education (MOE) should provide short-term skills training. Teachers must be trained in the use of new technology to be applied in the classroom (Ambigapathy & Shanthi, 2005). In addition, the MEB (2013 - 2025) strategically outlined to ensure that all teachers ICT literate. Among the regulation was, teachers were required to pass an online diagnostic test by 2014. Those who did not pass this test are required to complete a series of online training modules and reoccupation basic diagnostic tests at the end of 2015.

It is the government's responsibility to ensure the rapid use of ICT in schools is to provide adequate funding. Government should allocate sufficient funds for ICT in the budget after analyzing the allocation of funds to the sector / less important parts. In this case the school authorities should also take the initiative to seek sponsorship from the outside to reduce government spending and increase access to ICT. Next, another proposal to increase access to ICT in schools is to integrate the language and context of ICT subjects. It can be performed by holding competitions in ICT innovation. Also, introduce the development of specific ICT to develop ICT materials that match the language and context. Moreover the integration can be done by setting up ICT applications or to a bilingual trilingual.

In addition, the Ministry should also put an ICT teacher in every school. This way can be implemented by introducing ICT options in Teaching Institutions. This option will be called ICT teacher, similar as the teacher counseling, special remedial teachers there now. They should be trained in ICT not only in handling ICT tools

as well but in terms of repairing. The availability of ICT specialist teachers in their schools then can ease the repair and replace equipment is happening quickly. Finally, the public and private institutions can encourage research on the use of ICT in school management. With this the school will recognize the importance of ICT in teaching and learning process in schools.

CONCLUSION

This study found that the mean frequency and form of using ICT among teachers who are working in rural schools remained within the moderate level. Moreover, time constrains become major issue for the teachers to use computer in their classroom teaching. In addition, the mean level of skills among teachers also was in moderate level. This shows that fewer rural teachers were given training and courses associated with the use of computer and ICT. Issues and challenges that arise on the use of computer and ICT in the classroom are related to time factor, training factor and attitude and more. This study also found that there are some rural teachers who are not directly interested in using this advanced technology. It is hoped that all teachers regardless of the place of their service, can change their perceptions on using computers and ICT application to facilitate the process of their teaching and learning.

It is undeniable that the use of computer and ICT tools and application in schools aimed to improve the quality of teaching and learning. By understanding the factors that barriers the use of ICT among teachers, we can make recommendations that are believed to increase the use of ICT among teachers more effectively and efficiently. Effective use of ICT tools and application in schools will help the government to achieve the aspirations of the latest Education Blueprint (MEB) from 2013 to the year 2025, especially in terms of knowledge and bilingual skills. In this regard, the main goal is to produce students who are competent and skill-full in the current digital era. School management plays a vital role in ensuring the implementation of ICT in classrooms is well-planned and well-organized. School management led by principals and principals' leadership style, are key factors in convincing teachers to use ICT in their daily classroom. Hence, further research on principals' role in ensuring the implication in ICT in daily lessons is suggested. More future studies suggested to be conducted on comparing ICT utilization in schools in rural and urban areas.

ACKNOWLEDGEMENT

This research was supported by the research grants BK034-2013(BKP) from University of Malaya, also with co-operation of principals and teachers from public primary schools in Kuala Selangor District, Malaysia.

REFERENCES

- Ambigapathy Pandian, & Shanthi Balraj. (2010b). Driving the agenda of learning by design in science literacy in Malaysia. *e-learning and digital media*, 7(3), 301-316.
- Ambigapathy Pandian, & Shanthi Balraj. (2005). Approaching Learning By Design as an Agenda In Malaysian Schools. In M. Kalantzis & B. Cope (Eds.), *Learning By Design*: Australia: Common Ground.
- Anderson J. (2010) *ICT TRANSFORMING EDUCATION: A Regional Guide*. Asia and Pacific Regional Bureau for Education, UNESCO Bangkok.
- Aida Suraya Md. Yunus (2009). ICT integration in Mathematics teaching and learning. Dalam Wong Su Luan, Mas Nida Md Khambari, Abu Daud Silong & Othman Talib. *Technology & Education*. (pp. 96-115). Serdang: Universiti Putra Malaysia Press.
- Azizi Yahaya, Shahrin Hashim, Jamaludin Ramli, Yusuf Boon, Abdul Rahim Hamdan (2007). *Menguasai Penyelidikan Dalam Pendidikan (Teori, Analisis dan Interpretasi Data)*. Kuala Lumpur: PTS Professional Publishing.
- Bajunid, I. (2001). Exploration of the multiple possibilities and equifinality of development initiatives in the transformation of societies: The case of E-learning in Malaysia. Paper presented at the ICEE 2001 in Kuala Lumpur. Retrieved from <http://www.e-mentor.edu.pl/xml/wydania/7/102.pdf>
- Bingimlas, K. A. (2009). Barriers to the successful integration of ICT in teaching and learning environments: A review of the literature. *Eurasia Journal of Mathematics, Science & Technology Education*, 5(3), 235-245.
- Bransford, J., Brown, A. L., & Cocking, R. R. (2000). *How people learn: brain, mind experience and school* (2nd ed.). Washington, D.C.: National Academy Press

- Bruniges, M. (2003). Developing performance indicators for ICT use in education: Australia's experience. online document. Available at: <http://www.unescobkk.org/education/ict/v2/info.asp?id=13249>, date accessed: 28/4/04
- Bovee, C., Voogt, J., & Meelisen, M. (2007). Computer attitudes of primary and secondary students in South Africa. *Computers in Human Behavior*, 23, 1762-1776.
- Grabe, M., & Grabe, C. (2007). *Integrating technology for meaningful learning* (5th ed.). Boston, New York: Houghton Mifflin.
- Grimus, M., (2000). *ICT and multimedia i the primary school*. Paper presented at the 16th conference on educational uses of information and communication technologies, Beijing, China.
- Hamidi, F., Meshkat, M., Rezaee, M., & Jafari, M. (2011). Information technology in education. *Procedia Computer Science*, 3, 369-373.
- Hussain, A. J., Morgan, S., & Al-Jumeily, D. (2011). How Does ICT Affect Teachings and Learning within School Education. *Developments in E-systems Engineering (DeSE), 2011* (pp. 250-254). IEEE.
- Lefebvre, S., Deaudelin, D., & Loiselle, J. (2006). *ICT implementation stages of primary school teachers: The practices and conceptions of teaching and learning*. Paper presented at the Australian Association for Research in Education National Conference, Adelaide, Australia.
- Lloyd, M. (2005) . Towards a definition of the integration of ICT in the classroom. In ARE 2005, AARE, Eds. Proceedings AARE '05 *Education Research - Creative Dissent: Constructive Solutions* , Parramatta, New South Wales.
- Malaysia Education Blueprint: Preschool to Post secondary Education (2013) . Ministry of Education. Kementerian Pendidikan Malaysia.
- Malaysia. (2001). *The Third Outline Perspective Plan 2001-2010*. Kuala Lumpur, Malaysia: Percetakan Nasional.
- Ministry of Education. (2006). Pelan Induk Pembangunan Pendidikan: 2006-2010. Edisi Pelancaran. Retrieved from www.moe.gov.my/pipp2006
- Mohd Majid Konting (2000). *Research Methods in Education*. Kuala Lumpur: Dewan Bahasa dan Pustaka
- Peeraer, J., & Van Petegem, P. (2012). Measuring integration of information and communication technology in education: An item response modeling approach. *Computers & Education*, 58(4), 1247-1259.
- Puteh, M., & Vicziany, M. (2004). Vision 2020, The Multimedia Supercorridor and Malaysian Universities. Retrieved from <http://coombs.anu.edu.au/SpecialProj/ASAA/biennial-Conference/2004/Vicziany+Puteh-ASAA2004.pdf>
- Rosnaini Mahmud & Mohd Arif b. Hj. Ismail (2008) Factors influencing ICT integration in the classroom: Implication to teacher education. *EABR & TLC Conference Proceeding*. Austria.
- Rowntree, D. (1981). *Statistics Without Tears: A Primer for non-Mathematicians* . London: Penguin.
- Shelly, G.B., Cashman, T. J., Gunter, R. E., & Gunter, G. A., (2004). *Teacher discovering compters. integrating technology in the classroom*. (3rd Edition). Australia: Thomson Course Technology.
- Suhaimi, B., Rose Alinda, B., Othman, B., & Azizah, B. (2007). An Integrated Framework for IT Governance in the Malaysisan Ministry of Education. Paper presented at Postgraduate Annual Research Seminar. Retrieved from <http://www.pps.fskm.utm.my/pars2007/pars/pars/after%20correct/Information%20System%20Management/suhaimiismail-correct.pdf>
- Tinio, V. L. (2003). *ICT in Education*. United Nations Development Programme-Asia Pacific Development Information Programme.

CRÈCHE AND SAFETY FACILITIES FOR INFANT DEVELOPMENT

Dr (Mrs.) Florence A. UNDIYAUNDEYE,
Department Of ECCEDE
Email: atube2001@yahoo.com
PHONE: NO. +234 805 742 2724/+234 806 412 7750

Essien, Amanbo EDUNG
Department of Educational Foundation
Federal College Of Education,
Obudu, Cross River State, Nigeria.

ABSTRACT: Infants learn new things through interaction with other children at home or a crèche where others are kept for safety by parents as they attend to various careers. Even though most parents may not know exactly the degree to which infants learn as they stay together at the crèche, this guides their development with proper facilities put in place by daycare centres. The crux here is the provision of safety facilities in the crèche for proper infant development during the first six months of child care in the crèche. The major question here is what is a crèche? Are crèches safe and reliable? What would the child do at the crèche? Finding out what infants learn and the safety of being a client at the daycare centre requires an understanding of the practice in the centre as regards the child ability to develop with reference to their stages of development which form coherence to a baby's world. Studying how crèche and safety facilities facilitate infant development needs an understanding of how crèches are run to stimulate baby's cognitive and social abilities for proper integration into the human world. The babies, toddlers and young children can play, learn, enjoy meals and rest under a safety facility provision with absolute strangers in a completely new environment with a feel of comfort and confident at the crèche.

Keywords: Crèche, Safety facilities, infant development, learning and social interaction, physical development.

INTRODUCTION

Intellectual, emotional, physical, cognitive and social development correlates with baby's development as they interact at the crèche in a safety environment. A crèche is a formal daycare or nursery childcare centre where babies, toddlers and young children are cared for in a safe and stimulating surrounding. Crèches cater for the children of parents with either full or part time jobs or activities to perform outside the home. Shatter (2011). This concept though new in the Nigerian education system, is picking up quickly with the ever-increasing number of nuclear families and working parents. It can be tasking and sometimes even heart breaking to leave one's little ones with absolute strangers in a completely new environment. For parents, they need to feel assured, comfortable and confident before leaving their children at the crèche or daycare. For making a choice of daycare or crèche, some key issues must be considered by parents; where is the location? Is it close to the home or work place? Some parents even check and verify the qualifications and experiences of the staff and the persons who primarily run it. Ideally the expectation is to be run by educated, experienced and trained professional who have a valid operating license. The ratio of caregivers to number of children to ensure a child's individual attention is preferred. (Schacter, Gilbert & Wegner 2009, 2011). A crèche should be a place where children are happy and secured away from home as parents go for livelihood. This breeds a child's wellbeing, emotional and physical development.

A child starting a childcare makes a new stage of family life and requires family getting use to it in terms of preparation for both the parent and child. Parents worry about how children will cope in their absence and whether a caregiver's care would substitute parent's care. Schultzer and Schultzer & Duane (201) is of the view that it is only natural if children miss a bit of their parents at first as they get admitted in crèche.

Both parents and children have suggested ways on how they can prepare for a change of life as the child goes to resume in crèche. Steel and Piers (2007) suggest that following on how parents chose the right childcare crèche for their children. The best approach is either to consider a range of childcare options to find one that suits the needs of you and child, look into day nurseries, child minders nannies or ask a relative to look after the baby. List also your favourite options, the ones that suits your working hours and budget and look at them in more details; what is the adult to child ratio? If the baby is still tender, there should be at least one carer to every three babies. What are the carer's qualification and experience in looking after babies and you may want to know if

you can trust them. Are there activities, books and toys that are right for the child's age? There should be plenty to do that engages the child and stimulates the child's development. What are the facilities like? The toilets, space indoors and outdoors for the children to play. If meals are provided they should be nutritious and suitable for the child's age.

Where is the childcare situated? Somewhere close to the home or workplace should be most convenient. An easy journey to childcare means you and your child can both start your days feeling relaxed. In the unlikely event of emergency, you can be there quickly. It is also worth talking to other parents too. They may have firsthand experience of childcare in your area.

When decision have been made about the preferred childcare for the child, the next step is to help the child get to know his/her new carer because the more familiar the child is with the carer, the happier he or she will feel being left with them. Arrange a number of visits, at least an hour long with the new carer. This will give the child a chance to relax and enjoy the time with the new person in his or her life with the support of the parents presence. It may also be useful if the child is to be looked after by a grandparent, toddler play groups or other relative a few times before parents go back to work. This will get the child used being away from parents and will learn that parents will always come back to them. A child's crying is unlikely to mean that he or she is unhappy at childcare or that the carer aren't doing their jobs properly but that he or she needs some time to adjust to the new environment through more support from other children, parents and carers in crèche. (Steel, Piers and Konig, 2006). As parents, when you are at crèche with the child, make an effort to show the child that you and her caregiver get along. This will assure the child of the parents' trust of the carer.

Crèche Policy Guidelines for Child Development

There are usually policies for parents, caregivers and play equipment at the crèche. The centre welcomes parents participation in the activities or operations of the centre to be discussed with the supervisor, who in turn can advice them on what opportunities available for the child. There is a complaint and suggestion book kept in the crèche in case of any dissatisfaction parents can enter their feelings on the book. But parents must refrain from being angry with the crèche staff in front of the children to upheld the morale of the centre. Crèche meetings are fixed with parents as scheduled. Parents are required to discuss their unhappiness in any regard and they should not feel it will be used against the child for this help in the service improvement. Parents are requested to encourage their children to listen to simple instructions given by the crèche staff (Xiang, Bride & Guan, 2004, Ole Frode, Kurt & Terri, 2010). Most issues are dealt with affectionately and redirected to other activities in perfection. Parents also are required to leave clear instructions on medication for proper administration of prescribed drugs if it is required during the day. Parents would always be consulted on where to seek medical attention if need be. No toy from home is allowed in the centre unless the child cannot stay without them. Looking after children is an enormous responsibility; let the caregiver not worry about toys. If such items must be sent the crèche staff are not held liable for damage (Ryan, Rich, Edward & Deci, 2000).

The belongings of each child need to be checked by parents at the end of the day during pick up time. In case of missing items, parents are to inform staff as soon as possible. Clear instructions are required if parents are travelling during the day and contact number particularly for any emergency. If children are sick or have an infectious illness, the child should stay at home within that period. Fees requirements by children must be paid appropriately as a responsible obligation by parents.

Care givers or carers are expected to wear smart cotton clothes, hair plaited or made into bun. Very essential jewellery are allowed, no long earrings and glass bangles for the glass bangles tend to break and may hurt the children hence best avoided. Working hours is not a time for chat with friends and family (Wigfield, Guthries, Tonks & Perencevich, 2004) Care givers should always remember that children are God's gift, they come into being and are much dependent on them and have a chance to learn social skills and appropriate behaviours. They are to be nurtured with love, patience and pleasantly. Foul language should be avoided in childcare for the children are quick to initiate and unlearning is always more difficult. Even distribution of work should be done to avoid confusion and resentment. Caregivers are expected to be truthful and honest as role models for the children. The children are expected to be attended to except when sleeping, even then, periodic checks on the infant for safety. The day care needs to be swept and moped as many times as required as otherwise ants may trouble the children. Also, dust all surfaces and remove cobwebs. The children are not to be compared as each is unique and will be gifted in one area or other. The kids need to be appreciated as often as possible for each small task taken. While arranging the furniture keep the children's safety in mind. Toys and linen need to be washed every week. Curtains need to be washed once a month. Play is essential for children to learn and grow. What kids learn while playing need to be watched. Werier & Bernard (2012) posits that when children play,

they figure out how things work, pick up new words and ideas, build strong muscles they can control, use their imagination solve problems, learn to cooperate with others. Note that as these children play, remember safety first, safe toys for young children are well made with no sharp parts of splinters and do not pinch, painted with non-toxic, lead free paint and easily cleaned and they should be frequently checked for safety.

Play equipment could be outdoor or indoor. Out door equipment like jungle gym, sea-saw, slides, sand pit, soft balls, swing, rope ladder are used by children under the supervision of carers according to their ages and requirements to prevent being hurt by themselves or other infants and children in the centre. Children catch a lot of fun as they play with these equipments but special attention must be given to where they are placed. Barneister & Vobs (2004) feels that slides should be placed under shady places to avoid sun burns during swing weather and sieved pebbles in sand pits to prevent stone being put in the mouth by smaller kids and small wooden horses arouse children socialization as they enter small spaces and have imaginary family living. Indoors hand's on toys like rattles, squeeze toys, balls, puzzles, bends and bound or card games build eye hand coordination, encourage ideas about how things work and faster cooperation and problem solving. Books and recorders are sources of joy for children and adults. Chose some to build on children's interest such as animals or silky words. Children who are read to in their early years usually become better readers. Art materials foster creativity and build skills that lead to reading, writing and seeing beauty in life. Infants who can grasp a maker will delight in the motion of scrubbing. Construction items like blocks building sets, and wood making are excellent sources that contribute to muscle strength and coordination. Experimental materials like sand, water day and musical instruments are ideal learning tools because children have much control over them as they relish their feeling and sound (Jones & Ishmael, 2008). Sleeping schedule for babies under one year is followed by their body clock while toddlers under 18 months to 2 years gradually the mid morning nap will be discontinued as they progress. Favoured sleep posture needs to be reported to parents. Some sleep on their tummy, some on their back and some sleep only if patted when sung to or rocked.

Toilet training is always a stress process but is usually complete only when the child independently is able to hold on till he/she gets to the bathroom. Toilet visits is built into daily schedule for young children while older children will be encouraged to use the toilet before leaving the crèche for outdoor activities or field trips.

Safety Facilities for Infant Development in Crèche or Day Care Centres

One of the most viable ways for proper infant and toddlers development in a crèche is to provide safety facilities or be safety conscious in the provision of facilities, every child is provided with a warm and secure environment and plenty of attention from a caring adult (Murphy & Jim, 2009 & Carvone, Shadil, Smith, Ronald, Fiori & Marina, 2006). Personalized schedules and tender interactions throughout the day encourages children to learn, develop and grow in their unique way. The following ideal crèche facilities would increase proper functioning of the infants and toddlers at their later years in their various fields of endeavour.

- Adequate room: Avoid overcrowding, which gives free movement and play, decrease chances of disease transmission and good ventilation reduces sweating.
- Adequate ventilation: Enough windows for free flow of fresh air, reduce air borne disease transmission
- Adequate lighting: Sunlight rooms usher in bright and happy mood, sunlight kills flies, mosquitoes, bacterial and viruses
- Adequate care givers: A ratio of one to three children
- Good general hygiene: Change clothes immediately on soiling. Change diapers when suited, wash children after feeding and teach children to wash their hands after toileting.
- Appropriate nutrition: Children under six months reformation far expressed breast milk, complementary feeds for infants above six months, prepared food to be heated slightly before feeding, fresh food be hygienically prepared, raw fruits and vegetables to be washed and care givers must wash their hands before feeding the kids.
- Timely medical care: There should be first aid for small injuries, abrasions, cuts, immunization should be strictly followed and contact a doctor for emergencies.
- Accident prevention: Avoid slippery floors, keeping sharp edged toys, furniture in the play areas, children should not be allowed alone in the toilet. The following must be kept out of he reach of children; blade, knife, scissors, nails, nuts, beads, small rubbers, pills, peanuts, beans, glass items, liquid medicines, kerosene, toilet-cleaning liquids, paints etc.
- Psychosocial stimulation: Small infants should be provided physical warmth and tenderness while older infants should be talked to and sung to, story telling session should be held, pictures and flash cards can be made for older children, children should not be beaten or threatened, older children should be encouraged to help in taking care of infants and children must feel secure in the crèche.

- Counselling to parents regarding breast feeding and use of expressed breast milk: Avoid bottle feeding, psychosocial stimulation that have interaction, child spacing and accident prevention at home
- Cost effective management: Crèche facilities should be affordable by parents.
- Idea of community crèche for women: Crèche near the work place should be a choice of parents. Parents could contribute toys and other stuff for psychosocial stimulation.

CONCLUSION

Good day care centres include a nice mix of activities during day to teach different skills such as singing, dancing and story telling. In the recent years, a lot of importance has been rightly placed on early childhood stimulation. Every effort is made to provide the children a rich environment with carefully chosen educational toys, books and music. Every child is provided with a warm and secure environment and plenty of attention from a caring adult called caregiver. A good crèche runs on open door policy and encourage parents to drop-in unannounced and become part of the day care community by helping with activities. Crèche focus in development and learning though play is a valued concept and day care owners would like to follow current official curriculum guidance in the way that they organize their day. A crèche is a place where children are secured and happy while away from home set up. It contributes to a child's well being, emotional and physical development. When children make a fuss at the end of the day on return, parents need be patient and give a chance for absence or being missed and they may want some hugs and attention and not a minus for criticisms or apportioning of blames yet.

REFERENCES

- Baumeister, R.F & Vohs, K.D (2004). Handbook on Self-regulations. Research Theory and Applications. New York: Guilford Press.
- Cervane, D, Shadel W. G, Smith, G. Ronald E. Feri, A & Marina E (2006). Self Regulations: Reminders and suggestions from personality science. Applied psychology. An international review SS (3) 333 – 385.
- Jones, J & Ishmael, A. (2008). The Human Factor: Inside the CIA's Oys functional intelligence culture New York: Encounter Books.
- Murphy, J & Jim, A. (2009). Inner Excellence, Mc Graw-Hill.
- Ole Fredrick, L. Foode, S. Kurt, M & Teri, F. (2001). European Early Childhood Education Research Journal Vol 18.
- Ryan, K, Edward, L, Richard, K & Deci I. (2000). "Intrinsic and Extrinsic Motivations: Classic definitions and New Directions" Contemporary Educational Psychology b251: 54 – 67.
- Schacter, D.L, Gilbert, D.L and Wegner, D. M (2009 & 2011). Psychology 2nd ed. New York: Worth.
- Shater, D. (2011). Psychology. United States of America. Catherine Woods. P323 – 351.
- Schultz, K & Schultz, Z & Duane, A. (2010). Psychology and Work Today. New York: Prentice Hall pp 121 – 122.
- Steel, P & Piers, K (2007). Essentials of Organizational behaviour. Upper Saddle River, NJ: Prentice Hall.
- Steel, P, Piers, K & Konig C. (2006). Integrating Theories of Motivation. Academy of Management Review 31: 889 – 913.
- Weiner, S & Bernard F. (2012). "Interpersonal and Intrapersonal theories of motivation from an attribution perspective" Educational Psychology Review 12 (1): 1 – 4.
- Wigfield, A, Guthrie, J.T, Tonks, S & Perenovic, K.C (2004). Children's motivation for reading: Domain Specificity and Instructional Influences. Journal of Research, 97, 299- 309.
- Xiang, P. Bride, M.C & Cuan, J (2004). Children's motivation in elementary physical education: A Longitudinal study. Research Quarterly for exercise and Sport 75 (1) 71 – 80.

PERSPECTIVES OF IRANIAN SECONDARY SCHOOL TEACHERS TOWARDS THE APPLICATION OF INTERACTIVE WHITEBOARDS TECHNOLOGY IN MATH CLASSES

Morteza BAKHTIARVAND

Department of English Language, Ministry of Education, Andimeshk, Iran.

Email: M_bakhtiarvand@yahoo.com

Reza Golmoradi

Department of Education, Ministry of Education, Andimeshk, Iran.

Email: faradanesh88@yahoo.com

Mehdi Keyhani

Department of Mathematics, Ministry of Education, Andimeshk, Iran.

Email: Parham8484@gmail.com

TCARTSBA : This study explored the attitudes of teachers towards the use of interactive whiteboards (IWBs) in English Language teaching and learning contexts, and also sought insights into teachers' actual use of IWBs in English language classes. The study also investigated possible factors affecting teachers' positive and negative attitudes towards IWB technology. Data were collected through questionnaires distributed to 82 teachers in different institutions across Andimeshk, Iran, from Secondary schools. Questionnaire results revealed that teachers have positive attitudes towards the use of IWBs in Math instruction and are aware of the potential of this technology. Responses given in interviews indicated that all Math teachers are supportive of IWB technology in their classes, and observations revealed that IWBs are used with their basic functions in Math classes. The statistical analysis revealed that the more teachers use IWBs, the more they like this technology.

Key words: Interactive whiteboard (IWB), attitude, Mathematic Teachers, Math Instruction.

INTRODUCTION

With the introduction of computer facilities into the education system, traditional teaching techniques are increasingly being enhanced or even replaced by techniques relying more on technology. Once concentrated in math and science classes, technology has also begun providing benefits to language teaching and learning. One recent popular computer based technology that has emerged is interactive whiteboards (IWBs). IWBs were initially developed for presentations in office settings, but over the last decade, starting from higher education, educational institutions have begun using them. According to some studies and reports based primarily on research in science, math or other content-based classrooms, the use of IWBs makes the learning and teaching atmosphere more enjoyable, creative, and interesting. There are also numerous claims about the benefits and positive impact of IWBs on learning, but these remain largely anecdotal (Levy, 2002).

With the incorporation of IWBs in teaching and learning settings, important changes have been observed in education, such as engaging more students in the lesson, using multimedia sources flexibly, and motivating learners easily. IWBs could be useful supplementary tools for education, providing the opportunity to bring in different kinds of multimedia resources, to access Internet sources with ease, and to increase student interest; however, maximum benefit from this technology, especially in language teaching and learning settings, requires further background knowledge and research (Anderson, 2007). Although there are many descriptive reviews and reports about the use of IWBs, it is beneficial for teachers and students to be familiar with the actual potential of this technology through empirical studies, including gathering the opinions of students and teachers, exploring its actual use in the classroom, and providing pedagogical advice for effective use of this technology.

Background of the Study

In recent years, computers and computer-related technologies, such as IWBs, have increasingly begun to be used in language teaching and learning settings. Technologically developed countries such as the UK, the USA, and Australia have invested a great deal of money in such technological equipment. With respect to IWBs in

particular, a national survey in England in 2005 found that nearly half (49%) of primary school teachers had used IWBs, and in secondary schools, 77% of math teachers, 67% of science teachers and 49% of English teachers said they had used IWBs (BECTA, 2005). There is increasing interest in the potential of this technology worldwide (Hodge & Anderson, 2007), including in countries like Iran, where, though this technology is quite new, it is attracting educators' attention day by day.

Interactive whiteboards have been argued to provide certain benefits for students. Firstly, using IWBs has been claimed to increase student motivation and enjoyment (BECTA, 2003a).

Secondly, they have been shown to enable greater opportunities for participation and collaboration, thus developing students' personal and social skills (Levy, 2002). Thirdly, they may eliminate the need for students to take notes, through the capacity to save and print what appears on the board (BECTA, 2003b). Another benefit is arguably that, with the help of an IWB, teachers can make clearer and more dynamic presentations and in turn the students can manage to deal with more complex concepts (Smith, 2001). It has also been argued that IWBs allow teachers to accommodate different learning styles and to choose materials according to the particular needs of students (Bell, 2002). Moreover, IWBs seem to enable students to be more creative and self-confident in presentations to their classmates (Levy, 2002). Finally, Bell suggests using IWBs for a variety of reasons. Since IWBs are colorful tools, they attract the attention of students and they may be useful not only for visual intelligent students, but also for kinesthetic learners because they allow touching and marking on the board.

IWBs may provide benefits for teachers as well. First of all, IWBs have been shown to provide teachers with a way to integrate Information and Communication Technology (ICT) into their lessons while teaching from the front of the class (Smith, 2001). Secondly, they may allow for spontaneity and flexibility, and for teachers to benefit from a wide range of web-based resources (Kennewell, 2001).

Thirdly, they permit teachers to save and print the notes they or their students write on the board (Walker, 2002). Furthermore, IWBs allow teachers to share materials with their colleagues via intranet at schools and use them again later, which saves time in preparing materials (Glover & Miller, 2001). Finally, interactive whiteboards have been argued to serve as encouraging devices for teachers to change their pedagogical approaches and use more ICT, which in turn can facilitate professional development (Smith, 1999).

Even though there are many reports claiming to show the advantages of IWBs, there are also a few studies pointing out the drawbacks of this technology. In a study conducted by Gray, Hagger Vaughan, Pilkington and Tomkins (2005), researchers found that some teachers complained that IWB-based lesson preparation and planning is time-consuming. Other teachers stated that too much PowerPoint use could lead to a "show and tell" style of teaching that may result in changing the role of the teacher into one of just a presenter of the topic in the classroom. In this case, the teacher may be seen as more passive and as less involved in the teaching process.

Smith, Higgins, Wall and Miller (2005) revealed that in order to use IWBs to their full potential and avoid such problems, there is a tremendous need for training and technical support for teachers. Teachers should be confident in using this technology, which can only be achieved by special training. Without training, the claimed benefits may not be experienced by the learners and teachers. Glover and Miller (2001) conducted another study that supports this idea, emphasizing many teachers' lack of overall ICT competence. Yet another problem that may arise with the introduction of IWB technology is a financial one. Schools have to spend a considerable amount of money in order to equip classrooms with this technology.

Since the late 1990s there has been an increasing use of technology in educational settings worldwide. Computer facilities such as wireless net, interactive whiteboards, and multimedia devices have started to enhance teaching and learning processes. Interactive whiteboards (IWBs) are a relatively recent technology, so there is not a great deal of scholarly literature relating to attitudes towards their use. The articles in the educational press and newspapers offer only anecdotal evidence and advice and the existing small-scale studies do not provide a full picture – particularly with respect to IWB use in the area of language instruction.

Various studies have investigated the attitudes of students and teachers towards CALL (Arkin, 2003; Bebell, O'Conner, O'Dwyer, & Russell, 2003) and several studies have looked at the student and teachers attitudes towards the use of interactive whiteboards in particular (Armstrong, Cardini, Castle, 2007; Schmid, 2006; Wall, Higgins, Smith, 2005). Of the latter studies only two looked specifically at IWB use in language learning contexts (Gray et al., 2005; Schmid, 2006), and of these, both were small-scale qualitative studies looking at specific groups of ESL learners and teachers.

The literature lacks therefore large-scale studies surveying specifically language teachers', learners', and administrators' views about the use of IWBs in EFL contexts and exploring the possible factors affecting these stakeholders' positive or negative attitudes towards IWB technology.

In Iran, Andimeshk, IWB technology is fairly new and there are not many institutions that use it currently for language teaching purposes. Since research studies may be helpful to educators deciding whether or not to invest in this new technology, this study will be a starting point to show the overall picture of IWB use in Iran, Andimeshk, student and teacher openness to their use, and their overall potential for language instruction. This study will include all of the stakeholders in language instruction settings by exploring teachers', students', and administrators' attitudes both qualitatively and quantitatively, so that educators may decide whether they should incorporate this technology into their teaching process or not.

Research Questions

- 1) What are the attitudes of Iranian EFL teachers towards interactive whiteboards?
- 4) How are IWBs used in EFL classrooms in Iran, Andimeshk?
- 5) What factors may influence Iranian students' and teachers' attitudes towards the use of IWBs in EFL classrooms?

Significance of the Study

IWB technology is becoming more and more widespread day by day since it appears to offer teachers and students opportunities to facilitate teaching and learning. Although there are many claimed benefits of IWB technology, it is the teachers who will have to exploit the features of IWBs and integrate them with their current teaching methodologies, and students who will be expected to be ready for such changes. Effective integration can be achieved once it is understood how much training is needed, how open teachers and students are to the idea of IWB use, and how much support can be expected from administrators. Since the literature lacks broad empirical studies investigating students' and teachers' attitudes towards IWB technology in language instruction, this study might provide more empirical results, including both qualitative and quantitative data, showing how language teachers and EFL students perceive IWB technology, and ultimately may help both teachers and students maximize the benefits of IWB technology.

This is the first study that will investigate the attitudes of students, teachers, and administrators towards the use of IWBs in language instruction settings in Iran, Andimeshk. Before deciding on whether to invest in any new technology, educators need to understand how much this technology may contribute to their particular teaching and learning process, and need to be aware of opinions of the people who are using this technology currently. This study will enable Iranian educational institutions in the language teaching field to make informed decisions about whether to invest in this technology, and to better understand what they need to do if they decide to make this commitment.

Methodology

Since this study was limited by the number of educational institutions that use IWB technology, there could not be equal distribution of the types of institutions. This study was conducted, therefore, in thirteen different educational institutions where IWB technology is used in Andimeshk.

Some of the students who participated in the study were preparatory class students in universities and high schools, others were in language schools taking English courses at different levels, and others were primary school students taking English classes at least two days a week. In any one institution, not all classrooms using IWBs in English classes were necessarily surveyed. In any institution, if there were more than three classrooms where IWBs were installed, the three classes in which IWB had been used most often were surveyed.

If the students' IWB exposure was the same, one sample from each grade and level was chosen at random. The age of students ranged from 6 to mid-40s since there were educational institutions ranging from primary school to language school. The highest student population in this survey belongs to university students (45%).

The teachers surveyed also came from these thirteen different educational institutions, and therefore ranged from primary school teachers to university instructors. They had varying degrees of experience in teaching English, with the majority (83%) having between 1-10 years experience. Among all English teachers in any

institution, only the ones with actual experience using this technology were involved in the survey. In order to see the actual use of IWBs in English classes, three hours of English lessons were observed. Two of these classes were observed in one university, and the other was observed in a secondary school. The criterion for choosing the lesson to be observed was the amount of the teacher's experience in using this technology.

Lastly, three administrators were interviewed to investigate their attitudes towards the use of IWBs. All administrators were from universities and they were chosen because they had either had enough knowledge about IWB technology or had participated in the decision-making process to purchase the IWB technology.

Instruments

Survey techniques and instruments were used in order to collect data in this study. Two questionnaires were employed in this study in order to collect data about the attitudes of students and teachers towards IWBs in language teaching and learning settings. Both the student and teacher questionnaires included five point Likert-scale items, open-ended and multiple-choice items, and apart from primary and secondary school students, the rest of the participants signed a consent form.

The first questionnaire elicited information about the attitudes of students towards IWB use in English lessons. The other questionnaire explored the attitudes of EFL teachers towards IWB use in the classroom settings. While writing the questions in the questionnaire, the researcher was inspired by Moss et al (2007) questionnaire on teacher and student perceptions of IWBs in core subjects.

Some teacher and student responses in Levy's (2000) study were also used to prepare the questionnaire items for this study. After the writing of the final version of the student's questionnaire in English, the questions in the student's questionnaire were translated into Iranian by the researcher and checked by a fellow English teacher, in case student participants would not understand some of the statements in English.

However, the teacher's questionnaire was written in English because it was felt that EFL teachers would easily understand the questionnaire items. In order to improve the questionnaires, a pilot study was conducted in Middle East Technical University's Foreign Languages Department. Forty students and five teachers participated in the study in total. After the study, two vague items in the teacher's questionnaire were changed in order to be clearer.

The reliability check with Cronbach Alpha resulted in the score of 0.79 for student's questionnaire and 0.78 for teacher's questionnaire. In the teacher's questionnaire, three opposite items were excluded before the reliability check.

In order to explore the attitudes of administrators towards the use of IWBs, an interview protocol was used. I conducted these interviews with the heads of the Foreign Languages Departments in three different universities. They were the administrators of the preparatory programs. The reason for including administrators in this study is that their attitudes are also important while deciding to purchase this technology and provide additional support for teachers. There were six questions in total, exploring the factors influencing their institutions' decision to purchase IWBs, their opinions about the benefits of IWBs, the most common problems stated by the EFL teachers, and general background information about the institution.

For the last research question, a video recording procedure was conducted. The purpose of this procedure was to observe the actual ways in which of EFL teachers used or benefited from IWBs in language classes.

PROCEDURE

It was learned that approximately seventy different institutions possess this technology, but only about twenty of them use it in language classes. I phoned the administrations of the institutions that use IWB in language classes to learn whether they actually use this technology or not. I found out that even though some of these institutions had purchased IWBs, they were not using them actively, maybe due to the need for training.

Some of the institutions requested official permission from the director of education in different cities, so I excluded those institutions from my list since it would take a long time to get that permission. At the end of this initial searching step, I made a list of fifteen institutions that use IWBs in EFL classrooms, and which consented to take part in this study. Two of the institutions ultimately did not send back the questionnaires, leaving a total of thirteen institutions surveyed. The return rate, in this case, is approximately 80% with student's questionnaire and 19% with teacher's questionnaire.

A preparatory classroom was selected randomly, taking into consideration that they had some degree of IWB use experience. Two teachers who had been using this technology for one year were selected for the piloting. The student questionnaires were distributed to the EFL students in the preparatory class and all the students completed the questionnaires.

The other questionnaire, which was designed for the teachers who use IWBs in English classes, was distributed to the teachers and five teachers completed this questionnaire. The researcher requested the students and the teachers to comment on unclear statements and to express their thoughts about the questions and the survey itself. The time spent for each questionnaire was also recorded. After the piloting, minor changes to improve the questionnaires were made with the help of the teachers' oral and written comments and the students' feedback.

After the minor changes in the questionnaires were made, the questionnaires were distributed to fifteen institutions by post. Three interviews were then held with the heads of three institutions. Six questions were asked to learn their beliefs about this technology. Three hours of English classes were recorded in different institutions, using a digital video camera. After the recording, the tapes were analyzed using a checklist to define the ways in which English teachers used this technology. The checklist, which was compiled on the basis of uses mentioned in the literature on IWBs, consisted of different activities and ways of IWB use, such as bringing in materials from the Internet.

Data analysis

All the items in the questionnaires were analyzed using the Statistical Package for Social Sciences (SPSS), with the exception of the two open-ended questions at the end of both the teachers' questionnaire and students' questionnaire.

In the interview with the administrators, there were six questions and they were analyzed through categorization of the responses in terms of positive and negative opinions. For every item statistically analyzed, frequencies and percentages were calculated. In terms of mean scores and standard deviations, the researcher excluded the option "No idea" from the variables in order to see only the degree of actual agreement and disagreement among the participants expressing a clear opinion.

Therefore, the calculation of mean scores ranged from 1.00 to 4.00. In this case, the scores between 1.00 and 1.75 meant that the participants showed their strong disagreement with a certain statement, 1.76-2.50 indicated disagreement, 2.51-3.25 showed agreement, and 3.26-4.00 corresponded to strong agreement.

In order to find whether there was a significant relation between different variables such as age, hours of IWB use/exposure and students' and teachers' having positive or negative attitudes towards IWBs, one-way ANOVA tests were performed. Interviews with the administrators were taped and transcribed by the researcher.

The transcript data were categorized according to administrators' positive or negative attitudes towards the use of IWB technology. The video records were analyzed and categorized according to the ways that teachers use IWBs in the literature. In addition, the open-ended responses from the students were first translated into English, and then categorized according to the sections in the analysis of the questionnaire data gathered from the students. Later, after each section of the analysis of the student questionnaire results, the related responses were added to the relevant sections in order to support or contradict with the students' or teachers' Likert-scale responses.

Results and Discussion

With the exception of section three, in which there were two open-ended response items, all sections in the questionnaires were analyzed statistically. The Statistical Packages for Social Sciences (SPSS) Version 11.5 was used to compute frequencies and percentages of each Likert-scale question.

All the Likert-scale items consisted of a 5-point format: strongly agree, agree, no idea, disagree, and strongly disagree. While calculating means and standard deviations, the option "No idea" was excluded from the variables in order to see only the degree of actual agreement and disagreement among the participants. ANOVA tests were also calculated to see whether there was a significant relationship between attitudes and various participant factors, including age, years of teaching experience, hours of IWB exposure, and type of the institution worked in. In addition, responses from the two open-ended questions were grouped according to the similar questions in the second section of the questionnaire and were discussed after each statistical analysis.

The interview transcript data were analyzed according to the responses of interviewees for each of the six questions. The researcher examined all the responses for each question in order to find similarities and differences between the attitudes of the administrators.

Finally, the observation data were analyzed in order to reflect the actual use of IWBs in English lessons and to what extent the potential of IWBs is exploited.

The results obtained from the analysis of the questionnaires are presented in four parts below. In the first part, the analysis of questions in the student questionnaire is presented according to six categories: learning, technical issues, affective factors, motivation, time/organization, and differences between IWBs and traditional whiteboards. In the second part, the responses given to the questions in the teacher's questionnaire are shown according to four categories: teaching, attitudes, motivation, and training. In the third part, the data gathered from the interviews are presented according to the six questions asked, and the similarities and differences between the interviewees' responses for each question addressing attitudes towards the use of IWBs are analyzed. The final part of this chapter is devoted to a presentation of the various ways of actual IWB use in English classes as seen during the class observations.

Part 2: Teachers' Attitudes towards the Use of Interactive Whiteboards

Section 1: Teachers' Attitudes Related to IWBs as Teaching Tools

The nine questions in this section of the teacher's questionnaire investigated teachers' attitudes towards the use of IWBs as teaching tools. Generally, the proclaimed benefits of IWBs such as saving time, enabling teachers to reach different sources, saving and printing students' work or examples, easing review, and allowing the opportunity to interact with the class face to face were included in the questionnaire statements to learn the teachers' feelings about these features of IWBs. The researcher also wanted to learn whether the teachers feel that they are more effective, efficient, and better managers of their classes when using IWBs.

Q1: Using the IWB resources reduces the time I spend writing on the board.

Q2: When using IWBs in the classroom, I spend more time for the preparation of the lesson.

Q3: I think using IWBs makes it easier to reach different sources and display them to the whole class immediately.

Q4: IWBs are beneficial for saving and printing the materials generated during the lesson.

Q5: I can give explanations more effectively with the use of IWBs.

Q6: With the help of using the IWB, I can easily control the whole class.

Q7: I think IWBs can be a good supplement to support teaching.

Q8: Using IWBs makes me a more efficient teacher.

Q9: Using IWBs makes it easier for a teacher to review, re-explain, and summarize the subject.

According to the mean scores in this table, except for the statement that using IWBs requires more preparation time, the teachers agreed with all statements in this category. The highest mean score belongs to question seven, which indicates that nearly all of the teachers (90%) agree or strongly agree that IWBs can be a good supplement for the language teaching process.

The questions in this section can be categorized into two subcategories:

Questions related to the benefits of IWBs and questions related directly to the opinions of teachers. Q7 and Q8 can be included in the category of teachers' opinions about IWBs and the rest could be mentioned in the category of benefits and drawbacks of IWBs. Of the second group, the results of the third item show that a majority of the teachers responded positively that IWBs make it easier for them to reach different sources and show them to the whole class at the same time.

Regarding the responses related to the ninth question in this section, it can be seen that a majority of the teachers believe that IWBs enable them to review, summarize, and reexplain a subject in an easy way. If we look at the results of the fourth question, we see that 73% of the teachers agreed that IWBs are useful for saving and printing out their students' work. Nearly two thirds of the teachers believe that they can give explanations more effectively by using IWBs. The results of the first question reveal that 78% of the teachers agreed or strongly agreed that using IWB-based resources reduces time spent in writing on the board during the lessons. Looking at the responses given for the sixth question, 72% of the teachers agreed that they could easily control the whole class from the front of the class.

For the second question, which has the lowest mean score in this category, 59% of the teachers disagreed with the idea that preparing for IWB-based lessons takes more time than for a regular lesson. This may indicate that these teachers use special software programs designed for certain textbooks because these programs provide a lot of different activities, exercises, and tests for the teachers, which eases the teachers' job in preparing extra materials. On the other hand, the results also reveal that 32% of the teachers agree with this idea, which suggests that these teachers try to prepare their materials by themselves, so they have to look for special materials and create appropriate materials for IWBs.

In terms of the results of the two questions related to teachers' opinions, nearly two thirds of the teachers agreed with the notion that using IWBs makes them more efficient teachers in the classroom. It is also seen that 90% of the respondents believe that IWBs can be used for supplementing the lessons, resulting in the highest mean score for any question.

Taking the open-ended responses into consideration, three teachers stated that using IWBs saves time for the teacher. Two teachers also reported their feelings that IWB-based lessons are more interesting for the students and therefore the teacher can teach more effectively. In the words of one of these teachers:

I think this technology is a great opportunity for the students and the teachers because my lessons become more interesting by using IWBs and I can include a great variety of sources (Teacher 7).

On the other hand, one teacher complained that the IWB software that was designed for the course book does not contain anything different from the units of the textbook, so he suggested generally that these supplementary materials should be improved.

Section 2: Teachers' General Attitudes toward the Use of IWBs

These seven questions aimed to investigate teachers' general attitudes towards the use of IWBs. The questions can be divided into subcategories of positive attitudes/feelings and negative attitudes/feelings. Q10 and Q12 may be thought of as positive attitudes because they directly looked at whether the teachers like using this technology and whether they have positive attitudes towards it. On the other hand, Q11, Q13, Q14, and Q16 can be considered as negative attitudes since they explored the negative feelings of the teachers while using IWBs, their negative attitudes towards this technology, their concerns about their students' readiness to use this technology, and doubts about their own readiness to use IWBs. Q15 is directly related to the preference of a traditional way of teaching over IWB technology, so it can be included in the negative category as well.

Q10: I like using IWB technology in my lessons.

Q11: I feel uncomfortable using IWBs in front of my students.

Q12: I have positive attitudes towards the use of IWBs in language instruction.

Q13: I have negative attitudes towards the use of IWBs in language instruction.

Q14: I do not think my students are ready for this technology.

Q15: What I do in class with traditional methods is sufficient for teaching English.

Q16: I am not the type to do well with IWB-based applications.

In terms of mean scores calculated, the teachers strongly agreed with questions ten and twelve, whereas they disagreed or strongly disagreed with the rest of the questions in this category. As is seen in Table 11, these remaining questions were actually expressing negative opinions, so the teachers' disagreement with them shows an overall positive attitude, and thus a consistency among the participants' responses is evident.

The results show that the majority of the teachers agreed that they like using IWBs in their lessons, and that they have positive attitudes towards them. Supporting this finding, only 6% of the teachers responded that they have negative attitudes.

There is a more mixed response when it comes to the question of whether there is a need for IWBs. Although 61% disagree that their traditional methods are sufficient to teach English, 25% agreed with this statement, which indicates that some teachers do not see the necessity of introducing this new technology into the teaching process. By disagreeing with question 11, the majority of teachers made it clear that using IWBs does not make them uncomfortable in front of their students, and most teachers (72 of the 82 surveyed) were confident that they themselves were suited to using this new technology.

Finally, in terms of what the teachers' attitudes towards their students' readiness for IWB use, more than two thirds of the teachers (79%) agreed that their students are 'ready' for this kind of technology.

Section 3: Teachers' Attitudes in terms of Motivational Issues

The questions in this section intended to investigate teachers' attitudes in terms of motivational issues. This section consisted of four questions in total. The questions aimed to gather information about teachers' opinions whether they think that using of IWBs makes lessons more enjoyable and interesting, helps keep the students' attention longer, and increases interaction, motivation, and participation of the students during the lessons.

Q17: I think IWBs make learning more enjoyable and more interesting.

Q20: I can keep my students' attention longer with the help of IWB technology.

Q21: I think IWBs increase the interaction and participation of the students.

Q22: I think my students are more motivated when I use an IWB in my lessons.

The mean scores and low standard deviations calculated show that the teachers agreed or strongly agreed with all the statements in this category. The mean score of question seventeen is the highest ($M=3.46$), which indicates that nearly all of the teachers (almost 88%) agreed that IWBs make lessons more enjoyable and interesting. Nearly 80% of the participating teachers agreed that the use of IWBs increases the interaction and participation of the students, and nearly two thirds of the teachers believe that their students are more motivated when an IWB is used in the classroom.

The responses given for the 22nd question in this category show that 78% of the EFL teachers agreed that they can keep their students' attention longer when they use IWBs during the lessons.

Two of the participants wrote in positive extra comments, stating that IWBs attract the students' attention and increase student participation.

On the other hand, two other teachers observed that when the classroom lights are dimmed, some of the students lose attention:

When the classroom is a bit dark, my students start to sleep and lose their concentration. I think only the curtains near the IWB should be closed and the back of the classroom might get light from outside so that students do not tend to sleep (Teacher 19).

In order to avoid loss of attention when the lights are dimmed, the curtains at the back of the classroom can be opened or the lights could be switched on at the back of the classroom so that darkness of the classroom does not affect the students negatively.

Section 4: Teachers' Attitudes Related to the Issue of Training

The last category of the teacher's questionnaire contained two questions addressing the specific issue of training for the use of IWBs: whether it is necessary and whether without it, they still feel comfortable using IWBs (see Table 12).

Q18: I believe that training is required to teach with IWB technology.

Q19: If I do not get sufficient training, I do not feel comfortable with using IWBs in the classroom.

The mean scores reveal that the teachers believe in the need for training, but are much more divided over whether such training is absolutely necessary in order for them to feel comfortable using IWBs.

According to the responses given for the 18th question, 63% of the participants agreed that training is necessary for the use of this technology. For question 19 however, there is a more mixed response. Although 34% of the EFL teachers report that they feel comfortable without any training while using an IWB, 51% of the respondents agreed that they do feel uncomfortable, if they do not get sufficient training.

Since the agreement score is higher than the disagreement rate, it can be said that the need for training is accepted as an important issue.

One of the teachers made the point that teachers themselves have a role to play in getting ready to use IWBs:

I agreed with the training requirement, but this is a skill that teachers must develop themselves, make time to explore this technology and its potential. If they do not make time, they will not use it effectively (Teacher 16).

This opinion indicates that it is the teachers' responsibility in part to learn to use this technology, but the administrators should also encourage teachers and plan training sessions for them. The comment may suggest that if a teacher does not have positive attitudes towards this technology or believe in its benefits, it might be difficult for him/her to become accustomed to using it.

Section 5: Factors Affecting Teacher Attitudes towards IWB Use

In this section, one-way ANOVA tests were performed to explore the relation between teacher attitudes and different variables such as age, experience, and hours of IWB use. The researcher wanted to check whether hours of IWB use, age differences, and experience of teachers can be connected to positive attitudes or negative attitudes. Correlations were sought between hours of IWB use, age, and experience variables and questions 10 (I like using IWB technology in my lessons), Q12 (I have positive attitudes towards the use of IWBs in language instruction), Q13 (I have negative attitudes towards the use of IWBs in language instruction), and Q15

(What I do in class with traditional methods is sufficient in teaching English). After ANOVA tests were performed, none of the relations were found to be significant except for that between hours of IWB use and liking the use of IWB technology.

The result in Table 13 shows that there is a significant relationship between the hours of the teachers' IWB use and the degree of liking the use of IWBs. Specifically, post hoc tests reveal a significant difference between the group with the lowest exposure (1-2 hours) and the group with the highest exposure (11+ hours).

In general, what this suggests is that as the number of hours of using IWBs increases, teachers' rating of how much they like using this technology increases as well. This is an important finding because as the teachers explore this technology day by day, its potential and difference from traditional whiteboards are seen by the teachers and they want to use it more often. It is also related to the feedback coming from the students because when the teachers hear positive feedback, they want to use this technology more enthusiastically, as one of the administrators noted in the interview.

CONCLUSION

The results in this study revealed that a majority of the students agreed that when audio and visual materials are used with IWBs, they can understand lessons better and feel that they learn more.

Regarding the teachers' responses related to teaching, the teachers strongly agreed that IWBs are a good supplement for teaching and that IWBs make it easier to show different kinds of materials to the class. In Levy (2002) and Lee and Boyle (2004), the teachers reported that IWBs make it easier to draw on a greater number and wider variety of information and learning sources and these sources can be used flexibly and spontaneously in response to different pedagogical needs. The findings in the current study agree with this notion that it is easier to reach different sources with IWBs and that the whole class can benefit from these sources at the same time.

Teachers in the current study also strongly agreed with the idea that the use of IWBs makes it possible to review, re-explain, and summarize a topic easily and effectively, since the saved or ready examples from the previous lessons and a great variety of other sources make it easier for the teacher to re-present the subject. This is similar to points raised in earlier studies. Most of the students in Glover and Miller's (2001) study, for example, reported that with the help of IWBs, their teachers were able to review things if they needed to study them again. More than two thirds of the teachers in that study also agreed with the idea that the opportunity to save and print out the students' work and other materials is a very useful facility of IWBs, and is in fact a feature unique to IWBs, a point noted in both Walker (2002) and Lee and Boyle (2004).

The only statement in this category that the teachers disagreed with was one suggesting that preparation of IWB-based lessons takes more time than for a regular lesson.

This finding contradicts with a participant's comment in Glover and Miller's (2001) study that IWBs require earlier and better preparation from teachers. Levy's (2002) study also revealed that most of the teachers felt that initial lesson planning and materials preparation such as nice flipcharts take a long time to prepare.

According to the findings in Moss et al. (2007), teachers reported preparing their own resources 78% of the time, and 42% of the time using commercial software. Although the findings in that study indicate that the

teachers mostly spend a long time to prepare their own materials, this study may indicate that Iranian EFL teachers are either using commercial software or are finding prepared IWB materials on the Internet since they report that it is not time consuming to prepare IWB-based materials. Although in the observations I conducted, there were not any teachers who used a software program, but the researcher knows that some teachers use software programs specially designed for certain course books, such as Face2Face. Since the number of observations is limited to three, it was not possible to verify the use of software programs in English classes.

The results of this study suggest that simply providing IWBs in some or all classrooms does not guarantee their use in language instruction as it was found out during the research. The students in the institutions where there is only one IWB equipped classroom complain that they have experienced this technology only once or twice a semester.

This lack of exposure may come from concrete problems such as lack of time or inability to schedule access to the IWB classroom, or it may come from the teachers' unwillingness to try this new technology and therefore reluctance to bring his/her students to the IWB classroom.

In especially crowded schools with one IWB classroom, it will be very difficult to schedule who will use it when. The solution to this problem can be installing IWBs into more classrooms or administrators' planning equal schedules to make it possible for every class to benefit from this technology. In addition, teachers may not only face some first-order barriers such as lack of equipment and time, but also second-order barriers such as lack of confidence (Lane, Ross and Woods, 1999).

Through professional guidance and assistance, these second-order barriers can be overcome and teachers may feel more confident and eager to benefit from this technology. Thus, administrators should arrange focus meetings with experienced teachers in using IWBs, establish a kind of sharing network among teachers in terms of materials, resources, and advice on IWB use, and encourage teachers to exploit this technology on their own with the help of experienced colleagues.

Another important and related issue is the need for training. As Hall and Higgins (2005) stated in their study, training sessions should be regular and should be viewed as a continuous process so that teachers can improve their ICT skills in order to use IWBs efficiently. This issue is also mentioned in Smith et al. (2005), where they note that in order to use IWBs to their full potential, there is a need for adequate training because inexperienced manipulations of IWB features decrease the value of this technology. Additional coaching personnel and time could be beneficial on a one to one basis and administrators can arrange training sessions that could be helpful for teachers to overcome their barriers and be more confident in using IWB technology. However, my research findings indicate that more than one third of the teachers responded that they can teach with IWBs without special training.

This may show that the teachers who are interested and good at ICT skills can easily adapt themselves to IWB technology. Therefore, training could be provided by administrators according to the individuals' technological knowledge, experience, and their individual needs to exploit this technology in education. Since most of the teachers in this study agreed that IWB technology is a good supplement for teaching, and both students and teachers have positive attitudes towards this technology, it can be argued that IWBs should be involved in the teaching process as much as possible. Although it depends on the institutions' budgets, once the decision is made to use IWBs, ideally it is advisable to install them in every classroom so that students do not have to change classrooms for IWB-based lessons. If this is not financially possible, there can be at least two or three classrooms that are equipped with IWBs.

In this case, it should be ensured that students be able to find the opportunity to go to those classrooms as much as possible. Students in this study complained that they can only rarely go to the "smart class", which prevents them from experiencing and benefiting from this technology. It should also be reminded that some publishers prepare IWB-based materials and there are a wide variety of free resources on the Internet suitable for IWB use.

Teachers and administrators may wish to contact the publishers for IWB-based materials, on the condition that they choose certain course books whose materials are ready for IWB use, or search the Internet to find extra materials. On a cautionary note, since in most cases a committee, not individual teachers, decides on the books to be used in an institution, a teacher who wants to use this technology with readymade materials may not find this opportunity. Another potential problem with using ready-made materials is that not many books are prepared with software programs, which would limit the teachers' choice if they want to benefit from these software programs. If they find the opportunity to choose course books provided with IWB software programs,

teachers may get help in the exhausting process of preparing extra materials for the class and save time by using these materials.

As a last point, educators and administrators should not simply rush to buy IWBs before purchasing one. They should search for and be informed about the different features of each IWB. Although most IWBs share similar features, some of them have distinctive functions and allow more interactive opportunities during the lessons, a particularly important aspect for language teaching. After the comparison of different trademarks, the cost of this technology should also be considered. If more classrooms are intended to be equipped with IWBs, low cost IWBs could be appropriate, whereas if this technology is going to be installed in just a few classrooms, more functionally active IWBs can be chosen. It should also be noted that the size of the IWBs is also important, for instance, in large classrooms, bigger sizes would be more appropriate.

In this study, thirteen educational institutions were surveyed, ranging from primary schools to universities. Although there are several more institutions currently using IWB technology in Iran, Andimeshk, time, travel constraints, and willingness to take part in this study reduced the number of institutions involved. In addition, in some institutions, there were IWBs, but they had not been installed yet, so those institutions were not included in this study.

In one of the institutions surveyed, IWBs have been used for more than four years, but the rest of the institutions have been using this technology for only one year on average. This meant that in some cases students and teachers were basing their opinions on only limited exposure – a fact which no doubt led to the high “no idea” response rate for some questions. It should also be taken into consideration that in many institutions in Iran, Andimeshk, IWBs are used more in subject classes such as math, science, and geography. Restricting the study to institutions in which IWBs are used in language classrooms also meant that the number of institutions included in this study is far fewer than the total number of institutions currently using IWBs.

Apart from one private primary school and one high school surveyed, all the institutions in this study have this technology installed in just one or two classrooms.

This limited accessibility again may have negatively influenced the extent to which IWBs are used since teachers find it difficult to share the same classroom among them. As noted above, this also meant that students and teachers in many cases did not have a great deal of exposure to lessons with IWBs, and at times could not comment on this technology appropriately. If all the participants in this study had had more experience with IWBs, they might have agreed or disagreed with the statements more easily.

The number of lessons observed in different institutions to see the actual use of IWBs in English classes was also limited. Again, time and travel constraints did not make it possible to include more observations in this study. In addition, some institutions did not consent to having their teachers observed during the lessons and did not allow video recording. Similarly, the study is limited by the few interviews with administrators, but time constraints did not allow for more.

This study investigated the attitudes of students, administrators, and teachers towards the use of IWBs, factors affecting their attitudes, and the ways that EFL teachers use IWBs. Although this study includes some qualitative data, more classroom observations can be carried out to investigate to what extent teachers' benefit from the potential of this technology as claimed in the literature. Such a study, if conducted in a longitudinal manner, could attempt to confirm the finding in this study that greater use correlates to more positive attitudes.

As one administrator in this study pointed out, IWBs may help improve classroom interaction because the teachers do not need to turn their backs on the class. Given the importance of interaction in language learning settings, it could be the particular focus of a classroom-based research study to look at whether or how IWB use contributes to classroom interaction specifically.

The effectiveness of this technology in language instruction settings should also be examined. Although IWBs are claimed to have an impact on learning in the short term, this has not yet been confirmed. It should be checked and seen what are exactly the real contributions of this technology through experimental studies in language learning settings. If not much contribution to learning is found, investment in this technology could be questioned and investors might rethink before purchasing this expensive technology.

REFERENCES

- Arkin, E. D. (2003). *Teachers' attitudes towards computer technology use in vocabulary instruction*. Unpublished Master's thesis, Bilkent University, Ankara.
- Bebell, D., O'Conner, K., O'Dwyer, L., & Russell, M. (2003). Examining teacher technology use implications for pre-service and in-service teacher preparation. *Journal of Teacher Education, 54*.
- BECTA (2003a). *What the research says about ICT and motivation*. Retrieved 20 January 2008 from www.becta.org.uk.
- BECTA (2003b). *What the research says about interactive whiteboards*. Retrieved 17 January 2008 from www.becta.org.uk.
- Bell, M. A. (2002). Why use an interactive whiteboard? A baker's dozen reasons! *Teachers.Net Gazette*. Retrieved 25 March 2008 from <http://teachers.net/gazette/JAN02/mabell.html>
- Glover, D., & Miller, D. (2001). Running with technology: The pedagogic impact of the large scale introduction of interactive whiteboards in one secondary school. *Journal of Information Technology for Teacher Education, 10*(3), 257-276.
- Gray, C., Hagger-Vaughan, L., Pilkington, R., & Tomkins, S.-A. (2005). The pros and cons of interactive whiteboards in relation to the key stage 3 strategy and framework. *Language Learning Journal, 32*(1), 38-44.
- Hall, I., & Higgins, S. (2005). Primary school students' perceptions of interactive whiteboards. *Journal of Computer Assisted Learning, 21*(2), 102-117.
- Hodge, S., & Anderson, B. (2007). Teaching and learning with an interactive whiteboard: A teacher's journey. *Learning, Media and Technology, 32*(3), 271-282.
- Kennewell, S. (2001). Interactive whiteboards – yet another solution looking for a problem to solve. *Information Technology in Teacher Education, 39*, 3-6.
- Lee, B., & Boyle, M. (2004). Teachers tell their story: Interactive whiteboards at Richardson Primary School.
- Levy, P. (2002). *Interactive whiteboards in learning and teaching in two Sheffield schools: A developmental study*. Retrieved 12 March 2008 from <http://dis.shef.ac.uk/eirg/projects/wboards.htm>.
- Moss, G., Jewitt, C., Levañiç, R., Armstrong, V., Cardini, A., & Castle, F. (2007). *The interactive whiteboards, pedagogy and pupil performance evaluation*. Retrieved 12 January 2008 from www.dfes.gov.uk/research/data/uploadfiles/RR816.pdf.
- Schmid, E. C. (2006). Investigating the use of interactive whiteboard technology in the English language classroom through the lens of a critical theory of technology. *Computer Assisted Language Learning: An International Journal, 19*(1), 47-62.
- Smith, A. (1999). Interactive whiteboard evaluation. Retrieved 27 May 2008 from <http://www.mirandanet.ac.uk/pubs/smartboards.htm> 107
- Smith, H. (2001). *Smart board evaluation: Final report*. Retrieved from <http://www.kented.org.uk/ngfl/ict/IWB/whiteboards/report.html>
- Smith, H. J., Higgins, S., Wall, K., & Miller, J. (2005). Interactive whiteboards: Boon or bandwagon? A critical review of the literature. *Journal of Computer Assisted Learning, 21*(2), 91-101.
- Walker, D. (2002). White enlightening. *Times Educational Supplement*, p.19.
- Wall, K., Higgins, S., Smith, H., (2005). The visual helps me understand the complicated things: Pupil views of teaching and learning with interactive whiteboards. *British Journal of Educational Technology, 36*(5), 851-867.

THE EFFECT OF USING SMART BOARD TECHNOLOGY ON IRANIAN EFL

Morteza BAKHTIARVAND

Reza GOLMORADI

Mehdi KEYHANI

Related literature indicates that the use of technology including the Smart Board has an important role in foreign language learning. It is also obvious that attitudes of learners including their motivation affect learning processes significantly. This study aimed to investigate if there is any significant relationship between the use of Smart Board technology in Iranian EFL university classes and the students' motivation to learn English. To test this hypothesis a questionnaire developed by Binnur (2011) was distributed among a group of 60 Iranian EFL university students. Data gathered were analyzed statistically. The result indicated that Iranian EFL university students had a positive attitude towards the use of Smart Board technology in their English classes.

Keywords: Smart Board Technology, Motivation, EFL classrooms.

USEFULNESS OF SPSS SUPPORT FOR STUDENTS OF ECONOMICS AND BUSINESS

Urban ŠEBJAN

University of Maribor, Faculty of Economics and Business, Slovenia
urban.sebjan@uni-mb.si

Polona TOMINC

University of Maribor, Faculty of Economics and Business, Slovenia
polona.tominc@uni-mb.si

ABSTRACT: Faculty of Economics and Business (University of Maribor) offers complex and useful knowledge in the field of statistics, so among other things the SPSS (Statistical Package for the Social Sciences) is part of students' courses. SPSS is the most widely used statistical package that is applied by professionals as well as by higher education institutions, and it represents the important IT support. For that reason in this paper we present conceptual model of the usability of IT SPSS support, which was tested on a sample of 300 undergraduate and postgraduate students of economics and business. The basis for conceptual model developed in this paper represents the expanded TAM model (Technology Acceptance Model). The conceptual model was verified using structural equation modeling (SEM). Based on the set of basic models, we examined connections between formed constructs of the TAM model and in this way we presented the results of the conceptual models. The study reveals that there is a positive relationship between perceived usefulness of statistics and perceived usefulness of SPSS, perceived ease of use of SPSS, and attitude towards using the SPSS. Research model was analyzed by using the SmartPLS and WarpPLS approaches. The examination of the usefulness of statistical information support for educational institutions represents a starting point for further pedagogical and software development, and it also provides an opportunity to increase the value of SPSS in planning of IT support.

Key words: TAM model, usefulness of SPSS, statistics, student, structural equation modeling (SEM)

INTRODUCTION

Students of economics and business sciences acquire differentiated knowledge of statistical methods and analyses in educational programs that the Faculty of Economics and Business (FEB) offers, which graduates can use in further education or at the workplace. Research shows that students perceive statistics as a field of study that is tedious and difficult and usually they study it against their will (Morton & Booth 1997, Gordon 2004). But the acquisition of knowledge of statistics is the basis for understanding the complex quantitative analyzes, which are used in the context of differentiated statistical software support. The teachers of statistics want the students to acquire understanding of statistical methods as well as to be able to apply statistical methods in solving the real-life business problems or scientific research questions. Garfield (2005) emphasizes that students have to learn about statistical approaches in the most practical manner, with the help of computer and application of the statistical software support. Students learn statistics better if they have experience in the implementation of the ideas in new situations. With the help of statistical software support students can change various assumptions and parameters of the models, analyze data and thus improve understanding and application of statistical software support.

Statistical software packages are designed for the explicit purpose of performing statistical analyzes. Different statistical packages such as SPSS, SAS, S-plus, Minitab, STATA, R, and others are available on the market over a long period of time. While development of these packages has focused on industry users' needs, they have also evolved into more menu-driven packages that are more user friendly for students and as a result students of economics and business studies in the educational process often discover the usefulness of SPSS statistical software support, which allows them to use a number of quantitative methods and statistical approaches for data analysis. To this end, we wanted to know how the usefulness of statistics is perceived by students and how it affects the use of the SPSS statistical software support.

The field of SPSS use in the educational process has not been studied extensively. Researchers tend to study the use of software tools and rather choose to focus on different software solutions and technologies which students acquire during the educational process. In particular, they focus on the study of computer use of information and communication technologies, e-learning, m-learning, accounting software, e-portfolio system and similar (Park

2009, Zafar - Kumah & Achampong 2010; Shroff et al. 2011, Edmunds et al. 2012, Sriwidharmanely & Syafrudin 2012, Mahat et al. 2013). Some researchers study the attitudes of students towards statistical software adoption, within the context of study process, especially in an online version (Yang et al. 2007, Hsu et al. 2009). Also the students' conceptual understanding of statistics has been recently researched by analyzing the perception of statistics, characteristics of students and their attitudes towards statistics (Bond et al. 2012, Lalayants 2012, Dempster et al. 2009). Since the researches that focus on the usefulness of statistical software support for students is in deficit, and since a greater emphasis is laid on teaching and learning of statistics (Adams et al. 1999), we have decided to study the usefulness of SPSS software support that is perceived by students of economics and business sciences.

The designing of the conceptual model was based on the Technology acceptance Model (TAM). The TAM is an adaptation of the TRA (Theory of Reasoned Action) which is conceived as a general structure designed to explain almost all human behavior and is based on the importance of an individual's beliefs for the prediction of his / her behavior (Fishbein & Ajzen 1975, Ajzen & Fishbein 1980). TAM model comprises external variables, perceived usefulness, perceived ease of use, attitude toward using, behavioral intention to use and actual system use (Devis et al. 1989). The TAM is extremely widespread and used to determine the usefulness of IT solutions, software support, and technologies in various fields of science. The TAM attempts to explain why individuals choose to adopt or not a particular technology when performing a task. The purpose of our paper is to verify the applicability of the TAM model to explore the applicability of SPSS software support in the field of education and at the same time expand it with some new factors, in our case, with the usefulness of statistics.

LITERATURE REVIEW

Conceptual Research Model

Development of the conceptual model was based on the usefulness of statistics as a basis for understanding the use of any statistical software, especially the obtained results. "Statistics is the science of the planning studies and experiments, obtaining data and the organizing, summarizing, presenting, analyzing, interpreting, and drawing conclusions based on the data" (Triolet 2011). Despite the fact that statistics grant us many benefits which derive from basic definitions of it, several researches analyze attitudes to statistics by the students (Roberts & Bilderback 1980), and only few are analyzing the perceived use of statistics. Some studies also found out, that there is only a small proportion of students who believe that statistic will be useful and important in their chosen career, even after the implementation of additional organized trainings (Hagen et al. 2013). Chiesi and Grab (2009) have studied the perceived importance of statistics among students and their findings were exactly the opposite from the expected – namely they expected the positive opinion of students regarding worth of statistics; but after additional training the decrease in perceived importance of statistics in students' personal and professional life was detected, and also students' feelings concerning statistics were less positive. Lo and Stevenson (1991) found that there was a positive correlation between the perceived importance of statistics and computer experiences among students. It was also found that the learning of statistics would be enhanced by more exposure to computer printouts to assist and to interpret of results. In addition to the computing experience, scientists stress that the students' attitude to statistics is mainly the consequence of their experiences in statistical or mathematical classes in the past course of education (Zhang et al. 2012). "Students learn statistics only if they actually practice statistics through a whole range of statistical activity supported by an appropriate computer package and discussion" (Petocz & Reid 2001). It was also suggested that using statistical software programs in the introductory statistics course would be one of the important ways to improve student knowledge of statistics and to positive attitudes of students towards statistics (Baştürk 2005).

The area of statistics also influences the extent and the nature of the needed computing expertise (Gentle 2004). In literature review we found that there was only few researches done on the usefulness of the SPSS statistical software support for students based on the concept of the TAM. For example Yang et al. (2007) have studied the usage of statistical software support by using the TAM model and they found that learning experience had some effect on the attitudes towards using statistical software. Based on the regression model, they showed that usefulness and ease of use had significant impacts on attitudes towards the statistical software support by students. Their research results revealed that the relationship between the usefulness, ease of use, and attitude was significant.

Hsu et al. (2009) examined the SPSS software support by using the TAM model, which involves external variables such as: computer attitude, statistical software self-efficacy, and statistics anxiety. The study found that there was a positive relationship between perceived ease of use and perceived usefulness of SPSS, but the

research was limited to behavioral intentions regarding the use of the SPSS (Hsu et al. 2009). Some researchers have also focused on the study of the SPSS and other support software (e.g. Excel) for better comprehension of statistics (Proctor 2002).

The development of the conceptual model in this paper was based on the TAM model, which in the early stages of development included two constructs, namely perceived usefulness and perceived ease of use of technology. Perceived usefulness is defined as “the degree to which a person believes that using particular system would enhance his or her job performance.” Perceived ease of use, in contrast, refers to “the degree to which a person believes that using particular system would be free of effort” (Davis 1989). Both constructs represent cognitive response, which is reflected in the attitude toward using representing affective response (Davis 1993). The TAM model is a good indicator of the success or failure of a system implementation (Turban & Volonino 2010). The key purpose of the TAM is to provide a basis for discovering the impact of external variables on internal beliefs, attitudes, and intentions (Lu et al. 2003). The researchers did extend the TAM with several external variables, which could be classified as technology factors, social factors, economic factors, individual factors, and behavior factors (Lu et al. 2003, Alshare & Alkhateeb 2008). Based on the theoretical platform of TAM model and its’ expansion with the multidimensional variable “usefulness of statistics”, we have designed the following hypotheses, which are presented in the conceptual model in Figure 1:

- H1: The higher the perceived usefulness of statistics, the higher on average is the student’s perceived usefulness of SPSS.
- H2: The higher the perceived usefulness of statistics, the higher on average is the student’s perceived ease of SPSS use.
- H3: The higher the perceived ease of SPSS use, the higher on average is the student’s perceived usefulness of SPSS.
- H4: The higher the perceived usefulness of SPSS, the higher on average is the student’s perceived positive attitude towards SPSS.
- H5: The higher the perceived ease of SPSS use, the higher on average is the student’s perceived positive attitude towards SPSS.

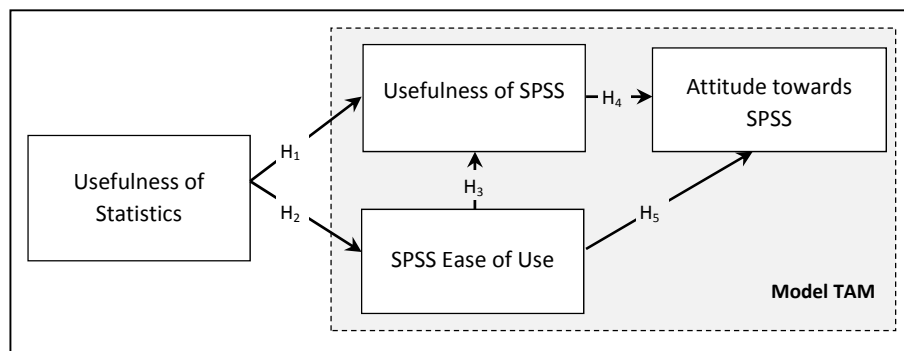

Figure 1 Conceptual Research Model

METHODS

Survey instrument

The questionnaire was designed in three phases; in the first phase we reviewed the literature, which has enabled us to develop a research model multidimensional variables - constructs. An important stage in the development process of the measuring scale represents the preparation of the statements (items) with which we explain several components of constructs of the research model. The research design consisted of three constructs arising from the TAM model (Usefulness of SPSS, SPSS Ease of Use and Attitude to SPSS) and one external construct (Usefulness of Statistics), that we formed and included into the expanded TAM model.

The construct “Usefulness of SPSS” was explained with five items (Davis 1989, Venkatesh & Davis 1996, Saad & Bahl 2005, Letchumanan & Muniandy 2013), the “SPSS Ease of Use” with five items (Davis 1989, Venkatesh & Davis 1996, Letchumanan & Muniandy 2013), the “Attitude toward the SPSS” with four items (Nah et al. 2004, Yi et al. 2006, Letchumanan & Muniandy 2013) and “Usefulness of Statistics” with six items (Davis 1989, Venkatesh & Davis 1996, Letchumanan & Muniandy 2013). In the second phase, we designed an

online questionnaire, which was pre-tested on a sample of 10 students. This phase resulted in a total of 21 items in the questionnaire. In the final third stage an online questionnaire was sent to students. All items were assessed using a five-point Likert scale from 1 = “Strongly disagree” to 7 = “Strongly agree”. The questionnaire included two questions gathering basic demographics, i.e., gender and field of study.

Data collection

The data was collected with an online questionnaire from 26th November 2013 to 17th December 2013. The study included a total of $n = 300$ undergraduate and postgraduate students who were acquainted with the SPSS statistical software support during their studies. Online questionnaire was sent to the students of various courses of economics and business sciences. All online questionnaires were duly completed. In the total sample, 33.9% were females, and 66.1% were males; 62.6% were students of undergraduate studies and 37.4% of postgraduate studies.

Data analysis

Statistical Package for the Social Sciences (SPSS), SmartPLS and WarpPLS software were used to analyze the reliability and validity of the data and to conduct structural equation modeling (SEM). The analysis of the data set was based on exploratory factor analysis (EFA) and confirmatory factor analysis (CFA). In the first phase we performed EFA, in which the principal component analysis and Varimax method were used. The Bartlett's Test of Sphericity (BTS), the Kaiser-Meyer-Olkin statistics ($KMO > 0.5$) and the statistically significant ($p < 0.05$) were calculated. In the context of EFA, we have examined factor loadings ($\eta \geq 0.5$), communality of variables ($h > 0.4$) and eigenvalues of factors ($\lambda \geq 1.0$).

In the second phase we conducted the CFA which was used to ascertain the efficiency of the measurement models, and SEM was used to test the conceptual framework and assumptions. To test the model the following rules were applied: average path coefficient (APC), average R-squared (ARS), average adjusted R-squared (AARS), average block VIF (AVIF < 5.0), average full collinearity VIF (AFVIF < 5.0), Sympton's paradox ratio (SPR ≥ 0.7), the R-squared contribution ratio (RSCR ≥ 0.9), statistical suppression ratio (SSR ≥ 0.7), nonlinear substantiated by an association causality direction ratio (NLBCD ≥ 0.7) and goodness-of-fit (GoF ≥ 0.5) (Schepers et al. 2005, Kock 2013). The quality of the measurement model was measured by the index of communality ($C > 0.5$) and index of redundancy (R). Based on the indices of cross-validated communality ($Q^2 > 0$), cross-validated redundancy ($H^2 > 0.5$) and variance explained by the model for a particular endogenous variable (R^2), we examined the predictability value of the structural model (Cohen 1988, Stone 1974).

In the next phase, we examined the reliability and validity of the measurement instrument, keeping in mind the Cronbach's alpha ($\alpha > 0.7$), index of communality and redundancy. Scale validity was analyzed by focusing on convergent validity, discriminant validity and nomological validity. As part of the convergent validity, we examined average variance extracted (ρc^{AVE}) and composite reliability coefficients ρc^{CR} , keeping in mind the criterion (Hair et al. 2010, Fornell & Larcker 1981, Bagozzi & Yi 1988): $\rho c^{AVE} > 0.5$ and $\rho c^{CR} > 0.7$ and the criterion by Byrne (2001) $\rho c^{CR} > \rho c^{AVE}$. To verify the validity of discriminants we considered maximum shared variance (MSV) and average shared variance (ASV). In discriminant force, we took into account two criteria (Hair et al. 2010): $MSV < \rho c^{AVE}$ and $ASV < \rho c^{AVE}$. Nomological validity is established when the correlations between the construct and question and theoretically related constructs are significantly greater than zero (Campbell 1960). In order to check multicollinearity, we used the variance inflation factors $VIF < 3.3$ (Cenfetelli & Bassellier 2009). For hypothesis testing, we used the path coefficient associated with a causal link in the model (β or γ), t -value, statistically significant ($p < 0.05$) and indicator of Cohen's effect (f^2) with size as 0.02, 0.15 and 0.35 for small, medium and large effect sizes (Cohen 1988).

RESULTS AND FINDINGS

Validity and reliability analysis

The results of the factor analysis for each construct indicate that it is meaningful to use EFA: Usefulness of Statistics ($KMO = 0.914$; $BTS = 1420.622$; $p < 0.001$), Usefulness of SPSS ($KMO=0.908$; $BTS = 1301.402$; $p < 0.001$), SPSS Ease of Use ($KMO = 0.866$; $BTS = 961.837$; $p < 0.001$) and Attitude to SPSS ($KMO = 0.858$; $BTS = 829.737$; $p < 0.001$). The EFA showed that all four constructs were one-dimensional whose own values were greater than 1.0. All the factors weights of the variables we used to measure individual constructs were higher than the value of 0.5. Therefore we excluded no items out of the individual constructs. 80.1 % of total

variance was explained by the “Usefulness of Statistics” factor; 77.4 % by “Usefulness of SPSS”; “SPSS Ease of Use” explained 78.0 %; and “Attitude toward SPSS” explained 84.4 % of the total variance.

Next, we employed confirmatory factor analysis (CFA). Four factors were created and used as latent variables. Item factor loadings were high, ranging from 0.790 to 0.942; and all were significant at the 0.001 level. To estimate the reliability of observed items, the R^2 values were used. The value of reliability of observed items were high, ranging from 0.624 to 0.887. As revealed in an examination of their values, all items did meet the 0.5 criterion.

Table 1. Convergent and discriminant validity of measurement models

Construct	Cronbach's α	ρ_c^{CRa}	ρ_c^{AVEb}	MSV ^c	ASV ^d	VIF ^e	Results of convergent validity	Results of discriminant validity
							$\rho_c^{CR} > \rho_c^{AVE}$ $\rho_c^{AVE} > 0.5$	$\rho_c^{AVE} > MSV$ $\rho_c^{AVE} > ASV$
US	0.950	0.960	0.801	0.652	0.460	3.007	yes	yes
U	0.941	0.959	0.812	0.516	0.544	3.946	yes	yes
EU	0.929	0.946	0.779	0.516	0.379	2.096	yes	yes
AT	0.938	0.956	0.844	0.602	0.534	3.405	yes	yes
Average	0.940	0.955	0.809	0.572	0.479	3.114	yes	yes

Notes: ^a ρ_c^{CR} refers to the composite reliability ($\rho_c = (\sum \lambda_i)^2 \text{var}(\xi) / [(\sum \lambda_i)^2 \text{var}(\xi) + \sum \theta_{ii}]$; (Bagozzi & Yi 1998)), ^b ρ_c^{AVE} refers to the average variance extracted ($\rho_c = (\sum \lambda_i^2 \text{var}(\xi)) / [\sum \lambda_i^2 \text{var}(\xi) + \sum \theta_{ii}]$; (Fornell & Larcker, 1981)), ^c MSV refers to the maximum shared variance, ^d ASV refers to the average shared variance; ^e VIF is the full indicator variance inflation factor; US is Usefulness of Statistics; U stands for Usefulness of SPSS; EU is SPSS Ease of Use; AT is the Attitude to SPSS.

To check the reliability of the constructs we tested convergent, discriminant and nomological validity. The ρ_c^{AVE} values for this model exceeded 0.5 for the reflective constructs (Hair et al. 2010), thus indicating convergent validity for all constructs. Composite reliabilities ρ_c^{CR} for the four reflectively measured constructs ranged from 0.946 to 0.960, exceeding the minimum requirement of 0.7. Table 1 shows the construct reliability for all four constructs: Usefulness of Statistics ($\rho_c^{CR} = 0.960$, $\rho_c^{AVE} = 0.801$); Usefulness of SPSS ($\rho_c^{CR} = 0.959$, $\rho_c^{AVE} = 0.812$); SPSS Ease of Use ($\rho_c^{CR} = 0.946$, $\rho_c^{AVE} = 0.779$); and Attitude to SPSS ($\rho_c^{CR} = 0.956$, $\rho_c^{AVE} = 0.844$). Since all the values ρ_c^{CR} values were higher than ρ_c^{AVE} values, we confirmed the convergent validity for all studied constructs. The internal consistency of the items in relation to the single trait within the instrumental was tested using Cronbach's α , ranging from 0.929 to 0.950. The discriminant validity of the measurement model was totally confirmed, where we kept in mind the suggested criteria ($AVE > ASV$ and $AVE > MSV$). All values ρ_c^{AVE} of individual constructs were higher than the maximum value of shared variance (MSV) and average shared variance (ASV). The results of the discriminant validity are shown in Table 1. The interconstruct correlations are all positive and significant. The results in Table 2 indicate that the model has complete nomological validity.

Table 2. Construct correlations and indicators of quality of research model

	M ^a	SD ^a	US	U	EU	AT	C	R	R ²	Q ²	H ²
US	4.456	1.417	0.895*				0.801	-	-	-	0.801
U	4.547	1.389	0.807	0.901*			0.812	0.219	0.714	0.580	0.812
EU	4.421	1.354	0.493	0.612	0.883*		0.779	0.190	0.244	0.189	0.779
AT	4.729	1.381	0.696	0.775	0.713	0.919*	0.844	0.342	0.696	0.562	-

Notes: ^aThe means and standard deviations are based on simple composites of the constructs, ^{*}Indicates square root of AVE; C-index of communality; R-index of redundancy; R²-variance explained by the model for a particular endogenous variable; H²-cross validated communality; Q²-cross validated redundancy; US-Usefulness of Statistics; U-Usefulness of SPSS; EU-SPSS Ease of Use; AT-Attitude to SPSS.

Structural model assessment

After the construct measures had been confirmed as reliable and valid, the next step was to assess the structural model results. Before interpreting the path coefficients, we examined the structural model for collinearity. The VIF values of these analyses ranged between 2.096 and 3.946, providing confidence that the structural model results were not negatively affected by collinearity. Explained variation R^2 for the endogenous latent variables is provided by Cohen (1988), where the value of 0.26, 0.13 and 0.02 represent strong, medium or low impact. The examination of the endogenous constructs' predictive power (Figure 2) shows that “Attitude toward SPSS”, which is the primary outcome measure of the model, has a substantial R^2 value 0.696. Prediction of “Usefulness

of SPSS” is higher with an R^2 value of 0.714, whereas the prediction of “SPSS Ease of Use” is comparably weak ($R^2 = 0.244$). The average value of R^2 is 0.551, which explains a large part of the variance of the endogenous variables. The quality of the measurement model was tested with the guarantee of communality (C) and the index of redundancy (R). The values of communality are all positive, ranging between 0.779 and 0.844. the average of its value is 0.809 and is higher than the threshold 0.5 (Henseler & Ringle 2009). Its value tells us that the quality of the measurement model for each block is at a satisfactory level. Values of redundancy are ranging between 0.190 and 0.342. Its average value is 0.250. The index of redundancy explained to us that the quality of the structural model for each endogenous block was at a satisfactory level. As for structural model, we have evaluated the guarantee of cross-validated communality (Q^2) and the index of cross validated redundancy (H^2). The values of Q^2 are ranging between 0.189 and 0.580. The average value of Q^2 is 0.443. The values of H^2 are ranging between 0.779 and 0.812 and are higher than the prescribed value of 0.5. The average value of H^2 is 0.797. All values of Q^2 and H^2 are positive, confirming the good predictability value of our measurement model.

Here we examined how the data fit the research model. One of the criteria that WarpPLS offers us is the coefficient of goodness-of-fit (GoF). A criterion of goodness of fit (GoF) for PLS was proposed as geometric mean of the average communality and the average R^2 by Tenenhaus et al. (2005). GOF is defined as small (0.35), medium (0.50) and large (0.61) (Zlatan & Ghozali 2012). The model in this study had a GoF value of 0.668; this indicates that the model fit was good. WarpPLS provided us with additional criteria for verifying data consistency within the research model. This assesses the model fit with the data, it is recommended that the p -values for both the average path coefficient (APC = 0.475) and the average R-squared (ARS = 0.552) both be lower than 0.05. Both coefficients are at the level of statistical significance of $p < 0.05$. Average values of the variance inflation factor (AVIF = 1.470) and average full colinearity VIF (AFVIF = 3.114) were lower than 5.0. The values of Sympson's paradox ration (SPR = 1.000) and R-squared contribution ration (RSCR = 1.000) achieve the ideal value, which was proposed 1,000. For additional research model fit the data values contribute statistical suppression ration (SSR = 1.000) and nonlinear causality bivariate direction ration (NLBCDR = 1.000), as both indicators exceed the suggested value 0.7 (Kock 2009).

Hypothesis testing

After verifying the adequacy of based conceptual model, we examined all hypotheses. All of our hypothesized relationships have been found significant at $p < 0.001$. In Figure 2 we present the relationships between individual constructs. Structural path coefficients of the proposed model, that are presented in Table 3, support the hypotheses formed.

Research results suggest that perceived “Usefulness of Statistics” by students has a positive and significant effect on perceived “Usefulness of SPSS”. The findings also provide support for H_2 , showing that the “Usefulness of Statistics” has a positive effect on the “SPSS Ease of Use”. We found that students perceived the important role of statistics in the use of the SPSS, as it provides a basis for understanding the SPSS. The SPSS gives us analytical approaches that require knowledge of statistics, which is a prerequisite for the efficient use of the SPSS. In addition, “Usefulness of Statistics” effect on “Usefulness of SPSS” is higher than its effect on “SPSS Ease of Use”.

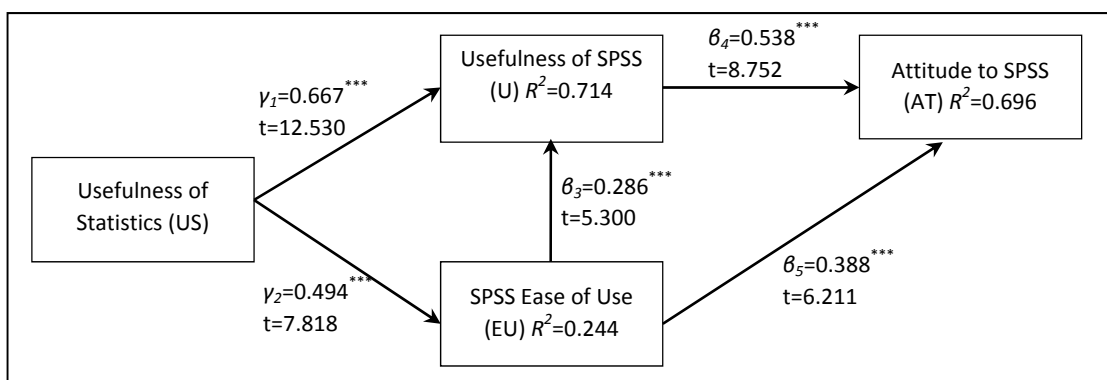

Note: *** $p < 0.001$; Based on $t(499)$; $t(0.05; 499) = 1.967$; $t(0.01; 499) = 2.594$; $t(0.001; 499) = 3.320$.

Figure 2. Results of structural model analysis

Results revealed that, as expected, the “SPSS Ease of Use” had a positive effect on “Usefulness of SPSS”, supporting H₃. Hypothesis H₄ and H₅ indicate the effects of “Usefulness of SPSS” and “SPSS Ease of Use” on “Attitude to SPSS” exist: the “Usefulness of SPSS” had a positive effect on the “Attitude to SPSS”, supporting H₄. Besides that similarly also “SPSS Ease of Use” showed a significant positive impact on “Attitude toward SPSS”, supporting H₅. Hypothesis H₁-H₅ were therefore all supported in this study.

Impact assessment f^2 (effect size) was used to assess the impact of latent variables in structural level model. The average f^2 0.331, represents a strong effect of latent variables. The strongest effect is perceived regarding the independent variable “Usefulness of Statistics”, which affects the dependent variable “Usefulness of SPSS”. Low-impact is perceived regarding the impact of independent variables “SPSS Ease of Use” on the dependent variable “Attitude toward SPSS” (see Table 3). From the results of the research, we can conclude that statistics has an important role in the use of the SPSS statistical software support. Students who perceive sufficient usefulness of statistics may understand more successfully the usage of the statistical software and perceive it as easy to use. From this we can further assume that students with higher perceived ease of use of statistical software SPSS on general perceive also a more positive attitude toward statistical software SPSS.

Table 3. Structural path coefficients for proposed model

Connection	γ/β	f^2	S.E.	t-value	p-value
γ_1 (US → U)	0.667	0.539	0.053	12.530	0.000
γ_2 (US → EU)	0.494	0.252	0.060	7.818	0.000
β_3 (EU → U)	0.286	0.173	0.055	5.300	0.000
β_4 (U → AT)	0.419	0.419	0.062	8.752	0.000
β_5 (EU → AT)	0.388	0.273	0.065	6.211	0.000

Notes: γ/β standardized regression coefficient; f^2 effect size; APC=0.475, $p<0.001$; ARS=0.552, $p<0.001$; AARS=0.549, $p<0.001$; AVIF=1.470; AFVIF=3.114; GoF=0.668; SPR=1.000; RSCR=1.000; SSR=1.000; NLBCDR=1.000

CONCLUSION

In this paper, we addressed the usefulness of SPSS for students of economics and business. We have developed a conceptual model which we derived from the TAM model. The TAM model was expanded with multidimensional variable “Usefulness of Statistics”. Although there were numerous studies about the use of IT solutions and technologies found in the literature, we detected a lack of research about the use of statistical software support for students, especially about the perceived usefulness of the SPSS. Therefore this represented a shortfall in this area of study that certainly called for further research.

In this study we have found that the perceived usefulness of statistics is important and definitely is a key factor for high perceived usefulness of SPSS and perceived ease of its use. It is not enough that students acquire knowledge of statistics they also have to learn statistics and perceive it as useful so as to efficiently use the SPSS. This certainly requires changes in the teaching process, in particular the use of real business cases. We have found relationship between the perceived ease of use of the SPSS and the perceived usefulness of SPSS, which is consistent to the conceptual model of Hsu et al. (2009). In this way, we found that among students who perceived the ease of use of the SPSS also perceived usefulness of the SPSS tends to increase. Next, we found that students who perceived the usefulness of the SPSS, had a more positive attitude toward the SPSS. At the same time, we found that students who increasingly perceived the ease of use of the SPSS also had a more positive attitude toward the SPSS. However, the connection between usefulness and attitude towards SPSS is significantly stronger, compared to the correlation between the ease of use and the attitude towards the SPSS. From the findings we can conclude that students placed greater emphasis on the usability of the SPSS and its practical application, both in the study, as later in business practice. Our findings are thus consistent with the findings of Garfield (2005), who stresses the need for the students to learn about statistical approaches in the most practical manner. The TAM model is therefore also useful for determining the applicability of statistical software such as the SPSS.

As already described the constructs “Usefulness of SPSS”, “SPSS Ease of Use” and “Attitude toward SPSS” were included based on the TAM model; besides them additional external variable, i.e., “Usefulness of Statistics” was included and expanded TAM model for the use of the SPSS statistical software support was formed. We performed our research on a sample of 300 Slovenian undergraduate and postgraduate students of economics and business sciences, and therefore we cannot generalize the findings to the entire population. Since the usefulness of statistical software support represents a deficient area of research, we perceive there are more opportunities for future research. The conceptual model could include additional constructs such as “satisfaction of use of SPSS” and “future intention of the use of the SPSS”. The TAM model could be expanded to the other

external variables such as educational support, compliance use of statistical software support with their studies in general or to the course of study, and also observed significant differences between undergraduate and postgraduate students, or between foreign and domestic students of economics and business studies regarding the perceived use of statistical software support. The scope of applicability of statistical programming support has a lot of potential for the use of experimental studies, in particular the verification of the effects of different pedagogical approaches.

RECOMMENDATIONS

Based on the findings of the research recommendations are formed for both the designers of statistical software support as well as for faculties and teaching staff that teach and use statistical software support. For the effective use of the SPSS students need an appropriate level of understanding of statistics, which is almost a precondition for the effective use of the SPSS. For the students to perceive the usefulness of statistics teachers should focus more on the preparation of study aids, which contain statistical simulation and real business cases that are actually prepared based on real-life business situations. Therefore the future research should also be oriented towards the study of pedagogical support for the use of the SPSS, as it is seen that the use of statistics and SPSS both require an adequate level of motivation in order to reduce statistics anxiety. For the students it is necessary to gain the insight about where and how to effectively use statistics and the SPSS in business practice. Organizations that are engaged in the development of statistical software support should consider developing friendly and simple, but innovative and useful enough SPSS software. It would certainly be appropriate to prepare the SPSS with appropriate additional explanations of statistical parameters and additional useful applications that are frequently used in business. This will definitely increase the perceived usefulness of SPSS for students of different study fields and create a more positive attitude towards SPSS.

REFERENCES

- Afari-Kumah, E. & Achampong, A. K. (2010). Modeling computer usage intentions of tertiary students in a developing country through the Technology Acceptance Model. *International Journal of Education and Development using Information and Communication Technology* 6 (1), 102–116.
- Alshare, K. A. & Alkhateeb, F. B. (2008). Predicting students usage of internet in two emerging economies using an extended technology acceptance model (TAM). *Academy of Educational Leadership Journal* 12 (2), 109–128.
- Ajzen, I. & Fishbein, M. (1980). *Understanding Attitudes and Predicting Social Behavior*. Prentice-Hall, Englewood Cliffs, New Jersey.
- Bagozzi, R.P. & Yi, Y. (1998). On the evaluation of structural equation model. *Journal of the Academy of Marketing Science* 16, 74–94.
- Bond, M. E., Perkins, S. N. and Ramirez, C. (2012). Students' Perceptions of Statistics: An Exploration of Attitudes, Conceptualizations, and Content Knowledge of Statistics. *Statistics Education Research Journal* 11 (2): 6–25.
- Basturk, R. (2005). The Effectiveness of Computer-Assisted Instruction in Teaching Introductory Statistics. *Educational Technology & Society* 8 (2), 170–178.
- Byrne, B. M. (2001). *Structural Equation Modeling with AMOS. Basic Concepts, Applications and Programming*. New Jersey: Lawrence Erlbaum Associates.
- Campbell, D. T. (1960). Recommendations for APA test standards regarding construct, trait, or discriminant validity. *American Psychologist* 15, 546–553.
- Cenfetelli, R. T. & Bassellier, G. (2009). Interpretation of formative measurement in information systems research. *MIS Quarterly* 33 (4), 689–707.
- Chiesi, F. & C. Primi. (2009). Assessing statistics attitudes among college students: Psychometric properties of the Italian version of the Survey of Attitudes toward Statistics (SATS). *Learning and Individual Differences* 19 (2), 309–313.
- Cohen, J. (1988). *Statistical Power Analysis for the Behavioral Sciences*, 2nd ed. Lawrence Erlbaum, Hillside, New Jersey.
- Edmunds, R., Thorpe, M. and Conole, G. (2012). Student attitudes towards and use of ICT in course study, work and social activity: a technology acceptance model approach. *British Journal of Educational Technology* 43(1): 71–84.
- Davis, F. D. (1989). Perceived Usefulness, Perceived Ease Of Use, And User Accep. *MIS Quarterly* 13 (3), 319–340.
- Davis, F. D. (1993). User acceptance of information technology: system characteristics, user perceptions and behavioral impacts. *International Journal of Man-Machine Studies* 38 (3), 475–487.

- Dempste, M. & N.K. McCorry. (2009). [The Role of Previous Experience and Attitudes toward Statistics in Statistics Assessment Outcomes among Undergraduate Psychology Students](#). *Journal of Statistics Education* 17 (2), 1–7.
- Fishbein, M. & Ajzen, I. (1975). *Belief, Attitude, Intention and Behavior: An Introduction to Theory and Research*. Addison-Wesley, Reading, MA.
- Fornell, C. & Lacker, D. F. (1981). Evaluating structural equation models with unobservable variables and measurement error. *Journal of Marketing Research* 18, 39–50.
- Garfield, J. (1995). How Students Learn Statistics. *International Statistical Review* 63 (1), 25–34.
- Gentle, J. E. (2004). Courses in Statistical Computing and Computational Statistics. *The American Statistician* 25 (1), 2-5.
- Gordon, S. (2004). Understanding students' experiences of statistics in a service course. *Statistics Education Research Journal* 3 (1), 40–59.
- Hagen, B., O. Awosoga, Kellett, P. and Ofori Dei, S. (2013). Evaluation of undergraduate nursing students' attitudes towards statistics courses, before and after a course in applied statistics. *Nurse Education Today* 33 (9): 949–955.
- Hair, J. F., Black, W. C., Babin, B. J. and Anderson, R. E. (2010). *Multivariate data analysis*. New Jersey: Prentice Hall.
- Hsu, M. K., Wang, S. W. and Chin, K. K. (2009). Computer attitude, statistics anxiety and self-efficacy on statistical software adoption behavior: An empirical study of online MBA learners. [Computers in Human Behavior](#) 25 (2), 412–420.
- Kock, N. (2009). *WarpPLS 1.0 User Manual*. ScriptWarp Systems, Laredo Texas. Retrieved online June 7, 2010 from <http://www.scriptwarp.com/warpls/UserManual.pdf>.
- Kock, N. (2013). *WarpPLS 4.0 User Manual*. ScriptWarp Systems: Laredo, Texas.
- Lalayants, M. (2012). [Overcoming Graduate Students' Negative Perceptions of Statistics](#). *Journal of Teaching in Social Work* 32 (4), 356–375.
- Latan, H. and I. Ghozali. (2012). Partial least Squares: Concept and application path modeling using program XLSTAT-PLS for empirical research, BP UNDIP.
- Letchumanan, M. & Muniandy, B. (2013). Migrating to e-book: a study on perceived usefulness and ease of use. *Library Hi Tech News* 7, 10–15.
- Lo, S. K. & Stevenson, M. (1991). Attitudes and perceived usefulness of statistics among health sciences students. *International Journal of Mathematical Education in Science and Technology* 22 (6), 977–983.
- Lu, J., Yu, C.-S., Liu, L. C. and Yao, J. E. (2003). Technology acceptance model for wireless Internet. *Internet Research* 13 (3), 206–222.
- Marton, F. & Booth, S. (1997). *Learning and Awareness. Mahwah*. New Jersey: Lawrence Erlbaum Associates.
- Park, S. Y. (2009). An Analysis of the Technology Acceptance Model in Understanding University Students' Behavioral Intention to Use e-Learning. *Educational Technology & Society* 12 (3), 150–162.
- Petocz, P. & Reid, A. (2001). Students' experience of learning in statistics. *Quaestiones Mathematicae*, Supplement 1: 37–45.
- Proctor, J. L. (2002). SPSS vs. Excel: Computing software, criminal justice students, and statistics. *Journal of Criminal Justice Education* 13 (2), 433–442.
- Roberts, D. M. & Bilderback, E. W. (1980). Reliability and validity of a statistics attitude survey. *Educational and psychological measurement* 40, 907–912.
- Mahat, J., Mohd Ayub, A. F. and Su Luan, W. (2013). Factors influence the acceptance of m-Learning in Malaysia: Perceived Usefulness, Perceived Ease of Use and Attitude. Proceedings of the 21st International Conference on Computers in Education. Indonesia: Asia-Pacific Society for Computers in Education.
- Nah, F. F.-H., Tan, X. and Teh, S. H. (2004). An empirical investigation on end-users' acceptance of enterprise systems. *Information Resources Management Journal* 17 (3), 32–53.
- Saad, R. & Bahli, B. (2005). The impact of cognitive absorption on perceived usefulness and perceived ease of use in on-line learning: an extension of the technology acceptance model. *Information & Management* 42, 317–327.
- Shroff, R. H., Deneen, C. C. and Ng, E. M. W. (2011). Analysis of the technology acceptance model in examining students' behavioural intention to use an eportfolio system. *Australasian Journal of Educational Technology* 27 (4), 600–618.
- Sriwidharmanely & Syafrudin, V. (2012). V. An Empirical Study of Accounting Software Acceptance among Bengkulu City Students. *Asian Journal of Accounting and Governance* 3, 99–112.
- Schepers, J., Wetzels, M. and de Ruyter, R. (2005). Leadership styles in technology acceptance: do followers practice what leaders preach? *Managing Service Quality* 15 (6), 496–508.
- Stone, M. (1974). Cross-validators choice and assessment of statistical predictions. *Journal of the Royal Statistical Society, Series B* 36 (2), 111–133.
- Suanpang, P., Petocz, P. and Kalceff, W. (2003). Student Attitudes to Learning Business Statistics Online vs.

- Tenenhaus, M., Esposito Vinzi, V. Chatelin, Y.-M. and Lauro, C. (2005). PLS path modeling. *Computational Statistics and Data Analysis* 48 (1), 159–205.
- Triola, M. F. (2011). *Essentials of Statistics*. Boston: Person.
- Turban, E. & Volonino, L. (2010). *Information Technology for Management. Transforming Organizations in the Digital Economy*. Hoboken: John Wiley & Sons.
- Venkatesh, V. & Davis, D. F. (1996). A model of the antecedents of perceived ease of use: development and test. *Decision Sciences* 27 (3), 451–481.
- Yang, H.-H., Yu, J.-C., Yang, H.-J., Han, W.-H., Li, Y.-J. (2007). Learning Experience is Important for the Attitude of Using Statistical Software. Proceedings of the 6th WSEAS International Conference on Applied Computer Science, Hangzhou, China, April 15-17, 165–169.
- Yi, M., Jackson, J. Park, J. and Probst, J. (2006). Understanding Information Technology Acceptance by Individual Professionals: Towards an Integrative View. *Information and Management* 43, 350–363.
- Zhang, Y., Shang, L. Wang, R., Zhao, Q., Li, C., Xu, Y. and Su, H. (2012). Attitudes toward statistics in medical postgraduates: measuring, evaluating and monitoring. *BMC Medical Education* 12 (117), 1–8.

COMPARISON OF DIFFERENTIATED APPROACH DEVELOPED WITH PURDUE MODEL IN TERMS OF ACHIEVEMENT

Esra ALTINTAŞ

Ahmet Ş. ÖZDEMİR

The aim of the research is to compare the differentiated approach developed by the researchers according to the mathematics education of gifted students who are at 5th grade with Purdue model developed for gifted students by Feldhusen and Kolloff and made its applications by the researchers according to the mathematics education of gifted students in terms of achievement of gifted students. The problem sentence of the study is as follows: Is there any effect of differentiated approach developed according to the mathematics education of gifted students on the achievement of gifted students compared with Purdue model? The subproblems of the research:

1. Is there any significant difference between achievement pre test scores of gifted students in control and experimental group?
2. Is there any significant difference between achievement post test scores of gifted students in control and experimental group?

In the present study it was used pre test -post test model with control group. The universe of the study consists of 5th grade gifted students who study at secondary schools included in Maltepe district of Istanbul. The sample of the study consists of 27 5th grade gifted students who study at a private school in Maltepe district of Istanbul. The data collecting tools are achievement test and multiple intelligence test.

It was concluded that there was a significant difference between pre test post test scores of gifted students in control group and experimental group. There was an increase both in control group and experimental group. But the increase in achievement scores are higher in the differentiated approach than Purdue model.

Keywords: Giftedness, Purdue model, Differentiated Approach

EDUCATION AND THE CHALLENGES OF SUSTAINABLE LIVELIHOOD IN EMERGING ECONOMIES: FOCUS ON RURAL ADULT EDUCATION FOR POVERTY REDUCTION IN NIGERIA

Peter A BETIANG

Elizabeth Aniah-BETIANG

S I AKPAMA

Merely asserting that education occupies the centre space in overall development of the individual and community is not only an understatement, but it is stating the obvious. It is known that the socio-economic imbalances and bondages that condemn a large percentage of the world population (80% for Nigeria) to live below the poverty line derives directly from the type, quantity and quality of skills acquired through education. The Education for All (EFA) initiative of UNESCO, sets out among other things to encourage the provision of a “Basic Education” for all citizens. This basic education is expected to stimulate an attitude of sustainable livelihood among its recipients, hence attempting to break the cycle of poverty –which is an inevitable accompaniment of a poor education. This paper examines the issues, problems and prospects of education for sustainability among rural poor illiterate and neo literate adults while attempting to chart a possible course for considered action in making adult basic education more meaningful and sustainable in the fight against poverty in Nigeria

Keywords: Education, Education for all, Adult basic education, sustainable livelihood, poverty reduction, illiterates and neo-literates

ROLE OF HISTORY OF MATHEMATICS ON EDUCATION OF MATHEMATICS

Saeed Seyed Agha BANIHASHEMI
 School Of International Realties
 ihusaied2001@yahoo.com

ABSTRACT:In this article we are going to discuss how new and old mathematics are related on works of Islamic mathematician and how history of mathematics can help education of mathematics to improve and motivate it.

INTRODUCTION

In history of mathematics we must study history of mathematics of all civilization because without study in this way we may do mistake .on basis of my project in Iran we collected about 6000 of mathematical manuscript of different libraries of about 1600 author. With these manuscript we came to know that fifth century of hijry was maximum activity of Islamic mathematician in the Islamic empire(indax1) % 30 of these are number theory and %30 is geometry and %30 is algebra and ten percent is application of mathematics. Intelligent people faced a religion, which in this religion science are most important phenomena

“ If today and tomorrow of Muslim are same they are not Muslim “

That means evry day Muslim must learn new things .So they studied Greek and Indian manuscript so a dry land was watered by Greek and Indian mathematics. In this condition Benmusa and their brothers employed Harni to translate these manuscript . So in other way they did history of mathematics the best one was Phage nasradin Tusi which in their manuscript we can see he state weakness and power point of Greek and Indian manuscript.

Role of history of mathematics on education of mathematics : -1
 One of the basic fact of history of mathematics it teaches to student that science is works of all -1-1
 civilization what ever we have are task of all civilization so nice feel comes to them that all people have
 cooperate in what we have now .Students with help of history of mathematics learn that big mathematician has
 done mistake so if they have done mistake can try again look to mistake of ferma on claim that $F_n = 2^{2^n} + 1$
,n=1,2,3,.....

Is a prime number uler proved that 641 are a factor of F_5 .

Most important of education of mathematics aim is make a quite and interesting class we have very nice and interesting story in greek, Indian, and Islamic mathematics which can help teachers to control the classes

Some example:

Example -1- Abolvafa Bozjani one of the famous mathematician of 328 of Hejry (940 .A.D) he had very nice books which all translated in English and French . In his book with the name geometry operation there is very beautiful problem can make student interest and better thinking as follow:

“How we can make with three equal square a new square “

Let the student thinks for few minutes and compare their work with Bozjani method

Solution: Let a,b,c three equal square we divide two of them into two parts by diameter as follow:

Example -2

Division of a line o equal part :If we want to divide AB into three part we continue from A and B in different direction

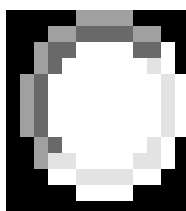

we call $BB' = a, AA' = 2a$ so $BM = (1/3)AB$.

Another important aim of education of mathematics is to learn better thinking history of mathematics have this tools. I think best problems for student for thinking is problems of all civilizations like trisection of angle, squaring circle,

trisection of triangle -2-1

In this section we see two method of trisection of angle from different civilization.

1-2-3-Hippas method .

When the given angle BAF is trisected as follow s:

- Construct a square ABCD on AB such that ray AF lies in the interior of $\angle BAD$. -1
- Draw the quadratrix DE and let X be its point of intersection with AF. -2
- Draw XC parallel to BA . -3
- Construct the point H on Ad such that $AH = \frac{1}{3} AG$. -4
- Draw HY parallel to AB -5
- Draw AY . -6

Then $\angle ABY$ is the required angle .

1-2-4- abosahl Kohi method.

He is one of the most importan mathematicians of fourth century(hejry) from south of Caspian Sea . He was magician he was interesting on central of gravity because of his job then he became interest to mathematics.

He start with following lemma:

Suppose we have semi circle AZD with diameter AD an center H with angle ABG we want to find E such that EZ parallel with BG then $EZ^2 = EH \cdot ED$

Now we consider method of Kohi for trisection of angle .

Continue AB up to D which length of BD is optional. Draw a semi circle with diameter AD which H is middle of AD .

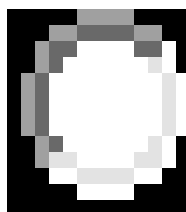

EZ is parallel such that $EH \cdot ED = EZ^2$ then draw EZ, ZD ,BT parallel to ZH in this case $\angle ABT = 2\angle TBG$. So $\angle ABG = \angle ABT + \angle TBG = 2\angle TBG + \angle TBG = 3\angle TBG$.

He prove above state as follow :

We have $EH \cdot ED = EZ^2 \Rightarrow \frac{ED}{EZ} = \frac{EZ}{EH}$ Since two triangle HEZ, ZED are common on E so these two are

analogous therefore $\angle EZH = \angle D$ but two arm ZH, HD of triangle ZHD are equal though $\angle HZD = \angle D$, $\angle EZH = \angle HZD$ but $\angle EZH$ is external angle of triangle ZHD. So

$\angle EZH = \angle HZD + \angle D = 2\angle HZD$ but $\angle BEZ$ is external of triangle ZEH we have $\angle BEZ = \angle EZH + \angle HZD = \angle HZD + 2\angle HZD = 3\angle HZD$ therefore $\angle EZH = (2/3)\angle ABG$ because BT is parallel ZH we have $\angle ABT = (2/3)\angle ABG$ in other way $\angle TBG = (1/3)\angle ABG$.

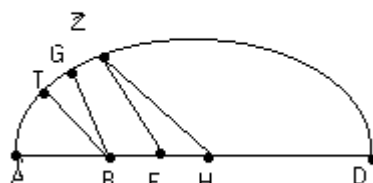

Squaring the circle is another problem which different civilization was interested.

It seems very simple according to idea of students but when they start to calculate they will see it is not possible because

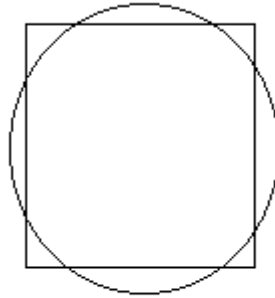

Area of a circle with diameter 1 is equal to $A = \pi R^2$ if $R = 1 \Rightarrow A = \pi$
 $A = x^2 \Rightarrow \pi = x^2 \Rightarrow x = \sqrt{\pi}$

Since π is unknown never we can find x . But different mathematician from different civilization tried to find a system to do drawing one these mathematician are Ramrujan from India though he had very short life but it was full so success.

Let PQR be a circle with center O of which a diameters PR. Bisect PO at H and let T be the point of trisection of OR near R. Draw TQ perpendicular PR and place the chord RS=TQ. Join PS and draw OM and TN parallel to RS. Place a chord PK=PM and draw the tangent PL=MN. Join RL, RK and KL. Cut off RC=RH. Draw CD parallel to KL meeting RL at D.

Then the square on RD will be equal to the circle PQR (in area) approximately. For $RS^2 = \frac{5}{36}d^2$

Where d is diameter of the circle.

Therefore $PS^2 = \frac{31}{36}d^2$. But PL and PK are equal to MN and PM respectively. Therefore

$$PK^2 = \frac{31}{144}d^2, PL^2 = \frac{31}{324}d^2 \text{ and hence}$$

$$RK^2 = PR^2 - PK^2 = \frac{113}{144}d^2 \text{ and } RL^2 = PR^2 + PL^2 = \frac{355}{324}d^2. \text{ But}$$

$$\frac{RK}{PL} = \frac{RC}{RD} = \frac{3}{2} \left(\frac{113}{325}\right)^{1/2} \text{ and } RC = \frac{3}{4}d.$$

$$\text{Therefore } RD = \frac{d}{2} \left(\frac{355}{113}\right)^{1/2} = r\sqrt{\pi}.$$

3- Another effect of the history of mathematics on education of mathematics especially for teacher is that they can understand the right root of formula in following we look to a list formula which named rungly :

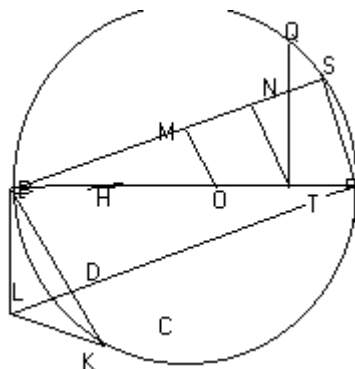

Correct
Ghyathedin Kashany (8 Hejry)

$$\sqrt[n]{T^n + r} \approx T + \frac{r}{(T+r)^n + T^n}$$

rung
Febunaji

$$\sqrt{a^2 + r} \approx a + \frac{r}{2}$$

$$\sqrt[3]{a^3 + r} \approx a + \frac{r}{(a+1)^3 + a^3}$$

Mahvira (900A.D)

$$C_r^n = \frac{n!}{(n-r)!r!}$$

Herigeone (1634)

Aryabatai(499 A.D)

Pell(1685)

$$Nx^2 + 1 = y^2$$

and so on .

Sources:

1- Indian mathematics Dr. Balchandra 1994 Janna Deep publication.

2-Episodesin the mathematicsof medieval Islam J.L Berggren

3-The historical roots of elementary mathematics –Lucas N.H.Bunt-Philip.S.Jones –Jack D.Bedient - Dover

THE USE OF X-RAY ANALYSIS TO STUDY THE RELATIONSHIP BETWEEN MICROSTRUCTURE AND IONIC CONDUCTIVITY OF $\text{CsAg}_{2-x}\text{Tl}_x\text{I}_3$

Samir Osman MOHAMMED

Physics Department, Science College, Ibb University, Ibb Yemen
samirbas@gmail.com

Mohammed HASSAN

Physics Department, Science College, Ibb University, Ibb Yemen
abuusef@gmail.com

ABSTRACT: This paper is a part of our investigations related to the effect of silver ion substituted by cations of different size on microstructure and ionic conductivity of the compound CsAg_2I_3 . This attempt is to find out the suitable structure in order to improve the ionic mobility. Here, the Iso-valent cation Tl^+ is replaced by silver ion in this compound. The X-ray diffraction data of the samples analyzed using Williamson-Hall method. The peaks of X-ray profile have been determined with more accuracy using PeakFit program. The results say that the lattice strain increases with increase of Tl^+ cation content. As well as, the ionic conductivity enhances due to the increase in the lattice strain. Unit cell parameters have been also refined and obtained using Chekcell software.

Key words: X-ray diffraction, ionic conductivity, PEAKFIT program

INTRODUCTION

The superionic conductor materials often have rather special structure that there are open tunnels or layers through which the mobile ions can move [1]. AgI is the most prominent superionic conductor which has the highest ionic conductivity in its α -phase that is stable above 420 K. Extensive efforts have been made to improve the conduction properties of this material by several methods [2, 3]. One of them is to modify the microstructure of the compound by introducing an iso- or an alio-valent cation into its lattice [4-6].

The microstructure of the solid is an important factor that determines its ionic conductivity in addition to the bonding characteristic of the material [7, 8]. The influence of the microstructure on the ionic conductivity of solids was studied by several techniques such as Impedance Spectroscopy (IS)[9], Transition Electron Microscopy (TEM) [10], and X-ray Powder Diffraction (XRPD) [11]. XRPD was found to be a powerful technique for the study of microstructure of materials [12], and has been used to investigate the relationship between the microstructure of the material and its ionic conductivity [13].

In this work, the microstructure properties of $\text{CsAg}_{2-x}\text{Tl}_x\text{I}_3$ ($x=0, 0.1, 0.2, 0.3$ and 0.4) samples were studied by XRPD. X-ray data were analyzed using different programs and software such as CHEKCELL program in order to refine the unit cell parameters, PEAKFIT software to identify and refining the peaks positions. The simple Williamson-Hall method was used to determine the crystal size and lattice strain. The relation between the microstructure of samples and their ionic conductivity was investigated.

Experimental

1. Sample Preparations

Silver iodide was prepared by precipitation from ammonical silver nitrate solution using ammonium iodide. Cesium and thallium iodides were obtained from Sigma-Aldrich, USA, with stated purity of 99.9%. The required amounts were mixed thoroughly using agate mortar and pestle to produce the series $\text{CsAg}_{2-x}\text{Tl}_x\text{I}_3$ ($x=0, 0.1, 0.2, 0.3$ and 0.4). The mixtures were then heated in an electrical furnace at 470K for 3 days with intermittent grinding. The final materials, white colour, were crushed to fine powders.

2. Conductivity Measurements

Conductivity measurements, at room temperature, were performed for rectangular pellets pressed under pressure of 4 tonnes/cm², with carbon painted on two opposite surfaces of the pellets. The measurements were carried out using HIOKI3532-50 LCR meter in the frequency range 40 Hz-5 MHz. The bulk conductance was obtained from Cole-Cole plots of impedance spectra.

3. X-ray Diffraction Pattern

The X-ray diffraction pattern of the sample was recorded using RIGAKU /MAX-B diffractometer employing X-ray radiation (λ for Cu K α . =1.54059Å) provided with copper anode. The recorded data of X-ray diffraction lines were performed by step scanning method in 2θ in the range $5^\circ - 100^\circ$ in steps of 0.05° . Figure (1) shows the scan of X-ray diffraction profile obtained from the sample and this profile was used for estimating the microcrystalline parameters of the ionic conductors CsAg_{2-x}Tl_xI₃ (x=0, 0.1, 0.2, 0.3 and 0.4) samples.

METHODS

It is well known that what causes peak broadening, resulting in the peak shapes [14]. If the sample is perfect and a perfect diffractometer have been used the diffraction peaks would be extremely sharp. So the broadening arises from two sources: instrumental contributions and sample contributions. In the last 50 years ago, the line-broadening theory of plastically deformed metals and alloys was developed. It recognizes two main types of sample contributions broadening: the size and strain components. The size depends on the size of coherent domains and the second factor is caused by any lattice imperfection [15]. Because of the nanocrystalline state of the studied samples, the Physical (sample contributions) broadening of the profiles was much higher than the instrumental broadening; therefore, instrumental correction was not applied in the evaluation [16]. There are many computer codes have been used to analysis x-ray line profile. We have used the residual-peak fitting software [17]. This program helps to detect, separate, quantify hidden peaks that standard instrumentation misses and background correction. PeakFit also includes 18 different nonlinear spectral application line shapes. There are three AutoFit Peaks options offered by PeakFit software. We have selected one of these options. In this option, the hidden peaks are detected by the "sharpening" achieved by deconvolving a Gaussian instrument response with the raw data. Baseline is also fitted with a Gaussian deconvolution procedure. Fitting procedure also ensures a good convergence factor. Figure (2) shows the snapshot of several individual reflections identified by peak fit procedure. We have used the standard cell parameters for CsAg₂I₃ [18] as starting values for "CHEKCELL" program to identify the Bragg reflections [19]. CHEKCELL program is a powder Indexing software.

Williamson-Hall method

This method relies on the principle that the approximate formulae for size broadening, β_L , and strain broadening, β_e , vary quite differently with respect to Bragg angle, θ :

$$\beta_L = \frac{K\lambda}{L\cos\theta} \quad (1)$$

$$\beta_e = 4\varepsilon \tan\theta \quad (2)$$

where K is the crystallite shape constant (≈ 0.89), ε lattice strain and L crystallite size. First contribution varies as $1/\cos\theta$ and the other as $\tan\theta$. The first contribution of crystallite size was measured by the Scherrer method as given in equation (1)[20,21]. If both contributions are present then their combined effect should be determined by convolution. The simplification of Williamson and Hall is to assume the convolution is either a simple sum or sum of squares. Using the sum of these we get:

$$\beta_{total} = \beta_L + \beta_e = \frac{K\lambda}{L\cos\theta} + 4\varepsilon \tan\theta \quad (3)$$

If we multiply this equation by $\cos\theta$ we get:

$$\beta_{total}\cos\theta = \frac{K\lambda}{L} + 4\varepsilon \sin\theta \quad (4)$$

and comparing this to the standard equation for a straight line (m = slope; c = intercept). We see that by plotting $\beta_{tot}\cos\theta$ versus $\sin\theta$ we obtain the strain component from the slope (4ε) and the size component from the intercept ($K\lambda/L$). Such a plot is known as a Williamson-Hall plot.

RESULTS AND FINDINGS

Figure(3) shows the variation of ionic conductivity of the sample as a function of Tl⁺ content. Ionic conductivity increases almost regularly with rising Tl⁺ ratio and appears to follow a linear trend. This is expected from the point of view that the planting of larger size cation into the lattice of CsAg₂I₃ creates additional available free volume in the lattice which facilitates the high mobility of Ag⁺ ions [22]. Moreover, the substitution by "wrong" size cation may cause local lattice distortion that affects the ionic mobility in the lattice of the solid [23].

However, we can give quantitative description for the structural changes arose due to the replacement of Ag⁺ by Tl⁺ that has been performed with the help of X-ray analysis of the samples. The cell parameters of the samples

have been refined using CHEKCELL PROGRAM and given in table (1). This table shows that there is a decreasing in c direction as Tl^+ content increasing. It is noted also fractional increasing of a parameter of the unit cell of the samples with increasing of Tl^+ content. This result has been illustrated in Figure(4). It has been found that the jumps of silver ions in AgI based ion conductors occur mainly in the direction [110] [24, 25], therefore these relative modifications in cell parameters may enhance the ionic conductivity by facilitating the ionic mobility in this direction.

By using PEAKFIT program, we have selected only permanent reflections for our analysis. The width at half maximum was determined for every reflection in all samples. The R^2 values for obtained widths approach from unity (≈ 0.99) which reflects the accuracy of the values. Then the equation of Williamson-Hall has been applied to compute the average of crystallite size and lattice strain of samples from the plot. Assuming one of the components in Williamson-Hall equation is neglected, we have calculated both parameters crystallite size and lattice strain for approximately 13 reflections in all samples. The anisotropic property has been noted clearly in the calculated values of crystallite size and lattice strain. One can say that the crystallite size in pure sample has high value in [0 4 0] direction, whereas the maximum lattice strain is at [3 2 1] direction. These maximum values for crystallite size and lattice parameters have been slightly shifted as doping Tl^+ inside the sample. The crystallite size has been influenced by Tl^+ content in the other directions. The results show that the increasing of Tl^+ content is changing the lattice strain in various directions with different values. The relationship between the average crystallite size and lattice strain with Tl^+ content of the samples have been plotted in Figure 5 and Figure 6. These figures explain the effect of doping with Tl^+ on the average of crystallite size and lattice strain. The lattice strain is incremented with rising of Tl^+ content in a similar that is observed with electrical conductivity. This result is consistent with previous expectations that the replacement with "wrong size" cation has led to increase of lattice strain of the solid and enhancing the structural disorder, which is one of effective factors responsible for ionic diffusion in solids [26].

Generally, the average of crystallite size slightly decreases with Tl^+ content. We have projected the crystallite shape into a plane so that a comparison could be made between the crystallite shapes of sample [27], using the equation

$$\left(\frac{2}{D_{hkl}}\right)^2 = \left(\frac{\cos \phi}{Y}\right)^2 + \left(\frac{\sin \phi}{X}\right)^2 \quad (8)$$

Here ϕ is the angle between (hkl) planes. This ϕ can be determined using the cell parameters. The resulting crystallite shapes were given in Figure (7). It is evident from this figure that the volume of the crystallite shape ellipsoid in $CsAg_2I_3$ comparatively more than that of others. From the crystallite shapes, one can say, that the average crystallite size decreases with Tl^+ content (as shown in Figure 5). In comparing Figure 5-a with Figure(3), one can conclude that the enhancement of ionic conductivity is associated with decreasing of crystallite size. This relationship can be explained by the increase of grain boundary and dislocation density in with decreasing crystallite size, which can provide a high diffusivity path for Ag^+ ions [28, 29].

CONCLUSION

X-ray powder diffraction has been applied successfully to study the relationship between ionic conductivity and microstructure of the ion conducting $CsAg_{2-x}Tl_xI_3$ system. The variation trends of cell parameters. Lattice strain and crystallite size of the material has been obtained by refining X-ray data and connected with those of electrical conductivity. The results indicated that there is coincidence between the increments of in ionic conductivity with increasing Tl^+ content is associated with increase in unit cell volume and lattice strain and with decrease of crystallite size.

REFERENCES

- West A.R., (2003), Solid State Chemistry and its Applications (student edition) John Wiley and Sons p. 453.
 Julio C. Baza'na., Nelson J. Garcí'a, Jorge A. Dristas, Carla V. Spetter, (2004), Ionic conductivity in montmorillonite-doped silver iodide, Solid State Ionics,17057-61.
 Didier Fasquelle, Jean-Claude Carru, Catherine Renard, (2007), Electrical characterizations of silver chalcogenide glasses, Journal of Non-Crystalline Solids 353, 1120–1125
 Keen, D.A., (2002), J. Phys. Condens. Matter, 14, R819.
 Rafiuddin, Mohammed Hassan, (2007), A superionic conducting phase in Cd-substituted $CsAg_2I_3$, Solid State Communications,144,293-295.

- S. Hull, (2004), Rep. Prog. Phys., 67,, p. 1233
- Chandra S., (1981), Superionic Solids. Amsterdam: North-Holland;.,
- Masaru Aniya, (2013), Understanding the mechanism of superionic transport from trends of materials properties, Physics Procedia 44 , 25 – 34.
- Christie G.M., F.P.F van Berkel, (1996), Microstructure ionic conductivity relationships in ceria-gadolinia electrolytes, Solid State Ionics, 83, 17-27.
- Yi Fei, Mori Toshiyuki, Ou Ding Rong, Drennan John, Relationship between Microstructure and Ionic Conductivity in Ytterbium Doped Ceria, Environmentally Conscious Design and Inverse Manufacturing, 2005. Eco Design 2005. Fourth International Symposium on, IEEE, pp.894-897, Tokyo, Japan.
- J.L. Narváez-Semanate, A.C.M. Rodrigues, (2010), Microstructure and ionic conductivity of $\text{Li}_{1+x}\text{Al}_x\text{Ti}_{2-x}(\text{PO}_4)_3$ NASICON glass-ceramics, Solid State Ionics, 181, 1197-1204.
- Samir Osman Al- Asbahi ; R. M. Kershi, (2012), The X-ray Diffraction Microstructure Analysis of Hexagonal Ferrite Powders Doped with La Rare Earth Ions , J Chem. Cryst., 42, 2, 155-158
- Pu, Zhao-Hui; Yang, Chuan-Zheng; Qin, Pei; Lou, Yu-Wan; Cheng, Li-Fang, (2008), X-ray diffraction characterization of the microstructure of close-packed hexagonal nanomaterials , Powder Diffr. 23, 213 (11 pages).
- Samir Osman M. and Mohammed Hassan, (2013), Microstructural properties and their influence on the ionic conductivity of $\text{CsAg}_{2-x}\text{Cu}_x\text{I}_3$ solid system, Radiation Effects and Defects in Solids, 168, 121-129.
- D. Balzar, (1999), *Defect and Microstructure Analysis by Diffraction*, R.L. Snyder, J. Fiala, and H.J. Bunge, eds., Oxford, New York, NY, pp. 95–126.
- [R. Delhez, Th. H. de Keijser, E. J. Mittemeijer](#), (1982) ,“Determination of crystallite size and lattice distortions through X-ray diffraction line profile analysis”, [Fresenius' Zeitschrift für analytische Chemie](#), , Volume 312, [Issue 1](#), pp 1-16.
- Gubicza J, Nauyoks S, Balogh L, Zerda TW, Ungár T (2007), J Mater Res 22:1314
- Runying Chen, Kathryn A. Jakes, Dennis W. Foreman, (2004), Peak-fitting analysis of cotton fiber powder X-ray diffraction spectra, Journal of Applied Polymer Science, [Volume 93, Issue 5](#), pages 2019–2024.
- Laugier, J.; Bochu, B. CHECKCELL, LMGP Suite of Programs for the Interpretation of X-ray Experiments, Ensp/Laboratoire des Materiaux et du Genie, Physique, Saint Martin D'heres, France, 2004. <http://www.ccp14.ac.in/tutorial/lmgp/> Accessed 19 September 2011.
- Scherrer P (1918) Göttinger Nachrichten Gesell 2:98
- Williamson and Hall (1953) Acta Metall 1:22.
- Sreejith M. Nair, A. I. Yahya, and Afaq Ahmad, (1996), Ion Conduction in the $\text{Ag}_2\text{HgI}_4\text{-Cu}_2\text{HgI}_4$ Systems Doped with Cd^{+2} , K^+ , and Na^+ , J. Solid State Chem. 122, 349–352.
- K. Singh, S.M. Pande, S.W. Anwane, S.S. Bhoga, (1998), A study of iso- and alio-valent cation doped Ag_2SO_4 solid electrolyte, Appl. Phys. A 66, 205–215
- A. Rahman and P. Vashishta, (1983), Physics of Superionic Conductors and Electrode Materials, Ed. by J. W. Perram (Plenum, New York,
- A. K. Ivanov-Shitz, (2007), Computer Simulation of Superionic Conductors: II. Cationic Conductors. Review Crystallography Reports, Vol. 52, No. 2, pp. 302–315.
- David A Keen, (2002), Disorder phenomena in superionic conductors, J. Phys.: Condens. Matter 14 , R819–R857.
- H. Mändar, J. Felsche, V. Mikli and T. Vajakas, (1999), new tools for estimation of crystallite size and shape by Williamson-Hall analysis, J. Appl. Cryst.. 32, 345-350
- Yuxia Wang, Liang Huang, Haiping He, Ming Li, (2003), Ionic conductivity of nano-scale g-AgI, Physica B 325 , 357–361.
- M. G. Bellino, D. G. Lamas and N. E. Walsøe de Reca, (2005), Enhanced Ionic Conductivity in Heavily Doped Ceria Nanoceramics, Diffusion Fundamentals 2, 47.1 - 47.2.

Table (1) The cell parameters of the samples

Sample with Ti^+ content	a - in Å	b - in Å	c - in Å
0.00	11.049	13.70	6.21
0.01	11.050	13.73	6.22
0.02	11.057	13.72	6.20
0.04	11.065	13.27	6.18

Table (2) The effect of TI+ content on the crystallite size and lattice strain parameters of the samples

Sample with TI ⁺ content	Crystallite size in Å	Lattice strain in %
0.00	833.82	0.19
0.01	805.32	0.18
0.02	723.60	0.25
0.04	356.86	0.47

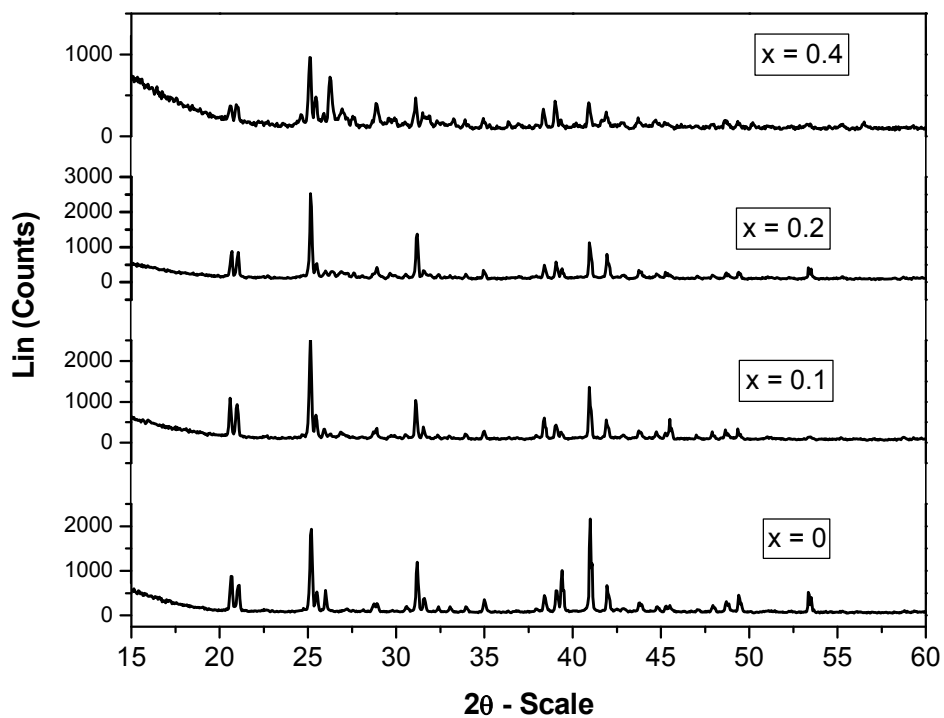

Figure(1) The X-Ray Powder Diffraction For Different Csag_{2-x}tl_xi₃samples.

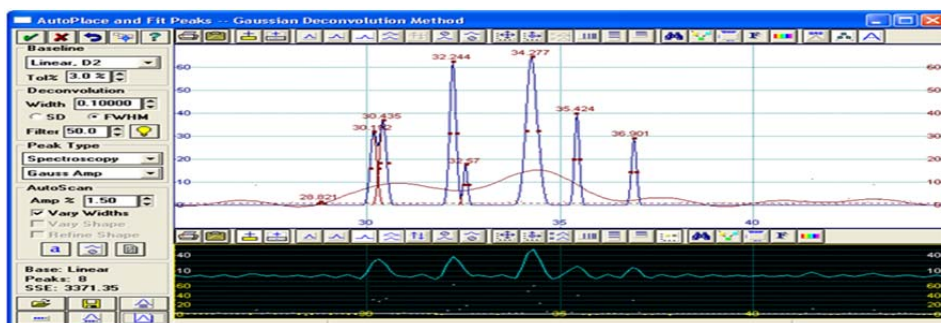

Figure(2) The Snapshot Of PEAKFIT Program For Some Reflections Of Sample(3)

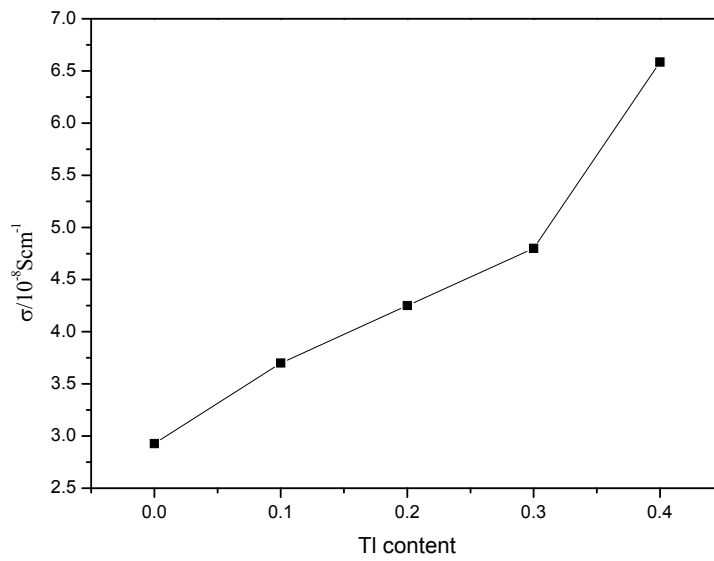

Figure(3) Shows The Variation Of Ionic Conductivity Of The Sample As A Function Of Tl^+ Content

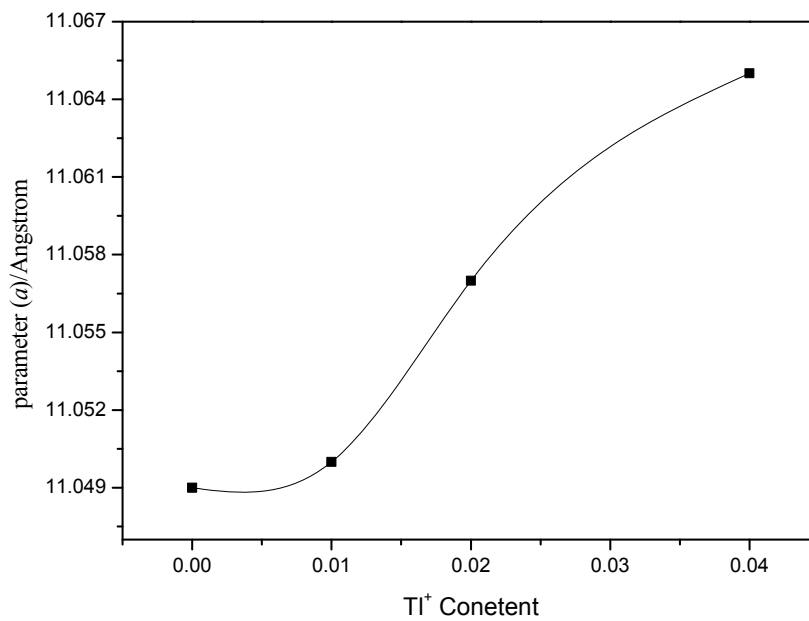

Figure(4) The Fractional Increasing Of A Parameter Of The Unit Cell Of The Samples With Increasing Of Tl^+ Content.

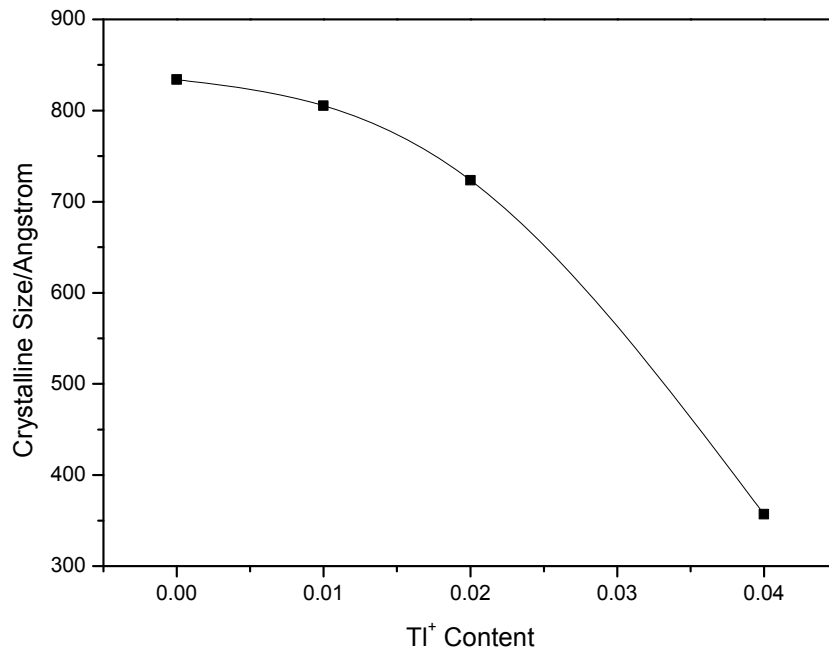

Figure 5. The Relationship Between The Average Crystallite Size And Ti⁺ Content.

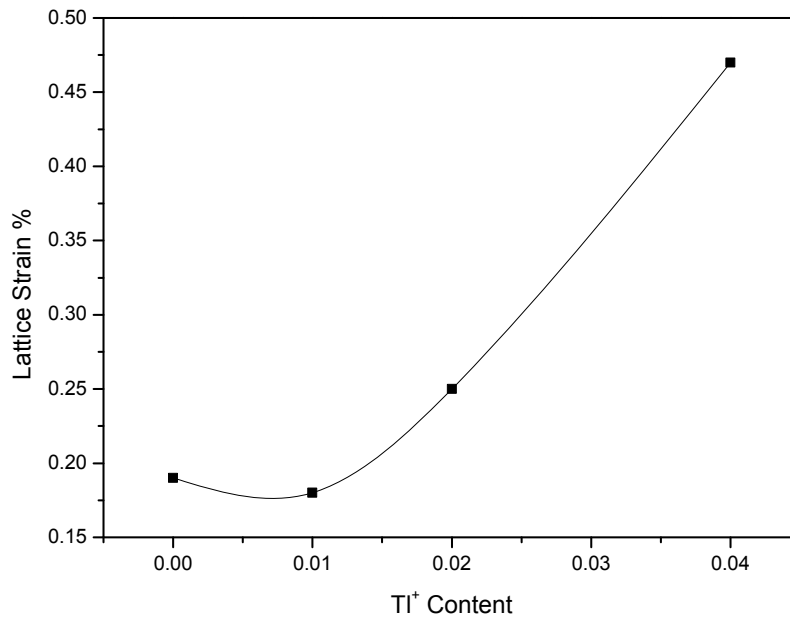
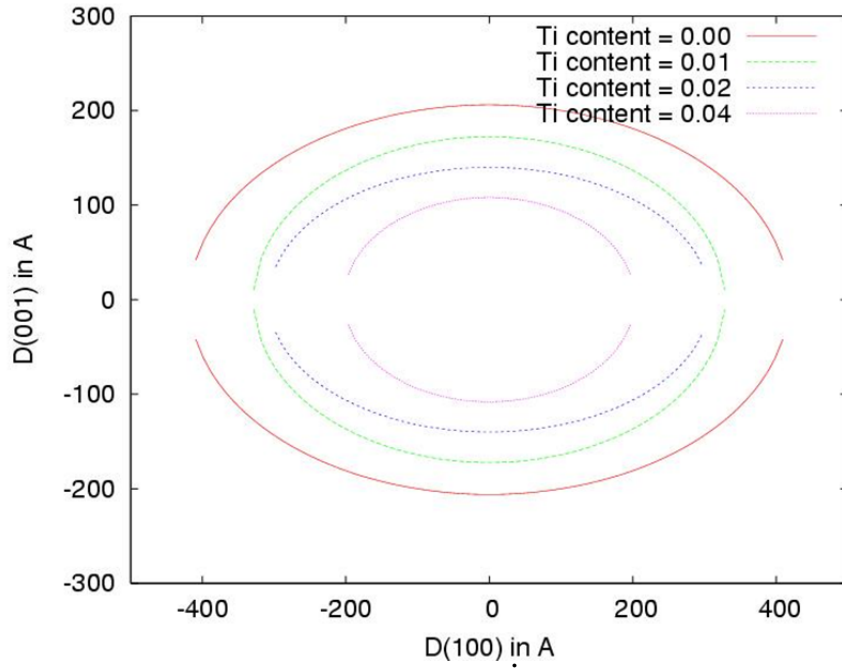

Figure 6. The Relationship Between The Lattice Strain And Ti⁺ Content.



Figure(7) The Crystallite Shape Of The Sample In The Direction Of [100] And [001].

INTERACTION EFFECTS OF TEACHER-PRESENCE AND STUDENTS' ACHIEVEMENT LEVEL OF SCIENCE PHYSICS WITH COMPUTER-AIDED LEARNING

Mohd Nor Jaafar Ph. D, Rafisah Osman Ph. D, Mustafa Ali Basyah M. Ed
& Rozalina Khalid M. Ed
School of Education and Modern Languages, Universiti Utara Malaysia
m.nor@uum.edu.my

ABSTRACT: This research aims to identify the impact of computer-aided learning (CAL) on the level of achievement in the subject of science-physics among high school students. The findings of the research showed the main effect of the CAL teacher-presence (no teacher and with teacher) and performance level (low and high) is significant. CAL teacher-presence (no teacher and with teacher) give different effects on performance in science-physics. The mean post-test for students with teacher group (74.79) was significantly higher than the mean for student with no teacher group (71.25). Similarly, the mean for the upper level students (75.35) is higher than the mean for the lower level students (71.67). Two-way ANOVA test showed the presence of CAL teacher-interaction (no teacher and with teacher) and the level of achievement (low and high) are not significant. Simple correlation test is carried out to find out the relationship between learning skills and attitudes towards learning in science-physics performance. The correlation analysis achievement and learning skills were shown positive and significant at the 0.05 level. Similarly, the relationship between students' attitudes and their performance shows a positive and significant at the 0.05 level. The findings of this research also showed that students perceived CAL as positive. Students also felt convenient and fun due to the effectiveness of science-physics learning using CAL. Based on these research findings, CAL should be promoted in science education, particularly for students with low achievement. CAL can be done in the classroom with the teacher as facilitators alone, or even at the high school open-learning organized by the students themselves. CAL is claimed as effective towards learning among students either with no teacher or with teacher.

Keywords: Computer-Aided Learning, science-physics, students' attitudes, achievement performance.

INTRODUCTION

Science-physics is a study about the phenomena of the world which existed through deep meaningful thinking and scientific research. According to Trowbridge dan Bybee (1990) science was known as a part of three basic facts namely the extent body of scientific knowledge, the value of science and; the methods and processes of science. Based on this science concept, it is claimed that science-physics is one discipline which contains dynamic relationship, experimental planning, observation, hypotheses, classification, measurement, data interpretation, summarization, making predictions and communicating learning output.

The performance achievement of science-physics in the Republic of Indonesia is at number 36 out of 45 countries in the world (Republika online, Koran Pendidikan, Jumaat 24 Disember 2004). This low achievement is claimed to be due to either the students' academic ability or the teachers' teaching ability. According to Zamroni (2001) the low achievement in science-physics is due to teachers' method of teaching. Teachers' lack in teaching methods can influence students' achievement because according to Sharma dan Mc Dermott (1990) the quality of science-physics depends greatly on the teaching quality and teachers' professionalism.

This research is done to identify the effectiveness of using computers in science-physics teaching and learning which in this study is known as CAL. CAL can make the students more active, build interaction among students, and learn to criticize or being analytical. CAL is used in the teaching and learning process and between students and teachers. The teachers, however, are expected to act as the facilitators and are able to become source of knowledge and as a consultant (Tabrani, 1994:181).

Teaching and learning using CAL also can increase students' motivation to learn the subject science-physics. The increase in learning motivation is able to encourage students to become more active and effectiveness in the teaching and learning will enable the students to achieve a higher performance in achievement (Dimiyati, 1994:78-79).

Science-physics lesson using CAL can provide students with the important concepts and the natural happenings of the world can become more interesting and meaningful for the students.

This is due to the fact that through students' activities using CAL, students are able to see in concrete the abstract concepts. This will help students grasp the concepts easily (Clard dan Mayer 2003). Making the abstract concepts concrete can be done through the preparation of updated and suitable audio visual aids for each lesson. Audio and graphics like pictures and video clips which have been programmed in the computer make teaching and learning easy. These teaching aids are constructed to make lesson more meaningful and can help increase students' understanding towards the science-physics materials. Teaching and learning that is more effective can increase students' understanding of concepts with reflection and the learning process all programmed in the computer (Dubinsky and Tall, 1991: 235).

PROBLEM STATEMENT

The education vision in Aceh is that all education is IT-based. In Aceh, at present, 20% of the schools are equipped with ICT facilities (Anas, 2007). Teaching and learning using computers or CAL is aimed to help students to make learning more effective. The problem is that although after seven years of implementing teaching and learning using IT, the students' performance and achievements in science-physics at the Sekolah Menengah Pertama in Aceh is still below the expected national level which is 70 to 100 percent.

RESEARCH OBJECTIVES

1. To identify the effect of teacher-presence towards the performance and achievement of students in science-physics lesson using computers.
2. To identify the effect of no teacher-presence towards the performance and achievement of students in science-physics lesson using computers.
3. To identify the relationship between science-physics learning skills and the performance and achievement of students with teacher-presence.
4. To identify the relationship between students' attitudes and the performance and achievement of students with teacher-presence.

RESEARCH METHODOLOGY

This research design is using the Control Group Posttest Only (Ary, 2007). It involves two independent variables and one dependent variable. The first independent variable is teacher-presence that is in two categories namely with teacher and with no teacher. The second independent variable is the level of academic achievements of the students in two categories namely the upper and lower levels. Meanwhile, the dependent variable in this research is the students' achievement and performance in science-physics

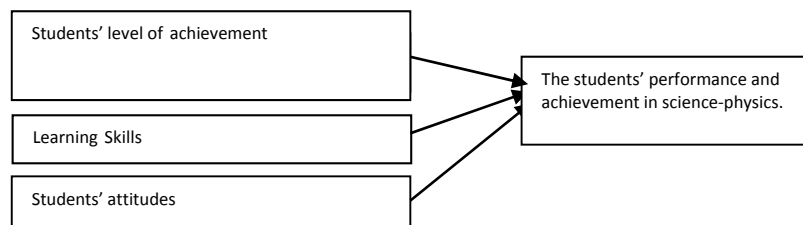

Figure 4.1: Research Framework

The factorial design 2 x 2 has produced four groups of students who are treated similarly that is learning with the aid of computers (CAL) to identify the effects of both independent variables. The categorisation of the groups is based on lower and upper levels of achievements which are sort from upper to lower levels for each selected class sample. The lower level group is identified through the value with is lower than the average

value, whereas, the upper level group is identified by the value that is larger than the average value (Suharsimi, 2000). The four experimental groups are shown in Table 3.1.

Table 4.1: Factorial Design 2 x 2

Level of achievement	Teacher-presence	
	(No teacher)	(With teacher)
Lower	1	3
Upper	2	4

Description 1 = Low level with no teacher. 2 = upper level with no teacher.

3 = low level with teacher. 4 = upper level with teacher.

RESEARCH SAMPLE AND POPULATION

The research sample consists of 68 Form 3 students who study science-physics from two schools in Kabupaten Pidie Jaya Propinsi Aceh Indonesia. The purposive sampling is to differentiate between rural and urban schools. The selection of which school became the control group or the experimental group was done at random. But, the selection of group that represents the lower and upper levels was based on the science-physics results of the students' achievement before CAL. The group that represents the upper level was indicated by collecting the score which was equivalent to the average score students got before CAL. The lower level group was determined based the score that is much lower than the average performance score before CAL.

The setting for which school represents group with teacher, or, CAL with no teacher and groups with teachers, it was done randomly. The distribution of groups for research sampling is as the table below.

Table 5.1: Factorial Research Sample Group

No	Teacher Presence (With/Without)	Level of Performance (Lower / Upper)	Students (N)
1	Without	Lower	21
2	Without	Upper	13
3	With	Lower	22
4	With	Upper	12
Total			68

RESEARCH FINDINGS

ANOVA 2 x 2 factorial analyses were used to analyse the data. The summarization of the ANOVA analysis output with regards to the interaction effects between the variables of the level of students' achievement and teacher-presence is shown below.

Table 6.1 ANOVA analysis output – Teacher presence and Level of Students

Source	Type III Sum of Squares	df	Mean Square	F	Sig.
Teacher presence (A)	251.257	1	251.257	18.039	.000

Level of Students (B)	230.062	1	230.062	16.517	.000
Teacher presence x Level of Students (A*B)	25.607	1	25.607	1.838	.180
Error	891.418	64	13.928		
Total	363923.793	68			
Corrected Total	1357.587	67			

a. R Squared = .343 (Adjusted R Squared = .313)

With reference to table 6.1, ANOVA test showed that the main effect of teacher presence is significant at $F(1, 64) = 18.039$, Sig, 0.000 atau $p < 0.05$. The effect of with teacher presence towards the students' achievement is higher significantly than without teacher presence. **The mean achievement of the group with teacher presence is higher significantly than the mean achievement of the group without teacher presence.**

The students' mean achievement based on teacher presence is shown in the table 6.2 below. Based on the table, the mean achievement of students without teacher presence is 71.25 while the mean achievement of students with teacher presence is 74.79.

Table 6.2: Mean Achievement of Students according to Teacher presence

CAL	Mean	N
Without teacher	71.2497	34
With teacher	74.7894	34

The main effect towards students' achievement is also significant, $F(1, 64) = 16.571$, Sig 0.000 atau $P < 0.05$. The main effect towards students' achievement in the upper level group is higher significantly than students' in the lower level group. The mean achievement of students in the upper level group is higher significantly than the mean achievement of students in the lower level group as shown in Table 6.3. The table shows that the mean achievement of students in the lower level group is 71.67 while the mean achievement of students in the upper level group is 75.35.

Table 6.3.: Mean Achievement of Students according to Students' Level

Level of Achievement	Mean	N
Lower	71.6665	43
Upper	75.3468	25

The interaction result between the variables in teacher presence with the students' level of achievement is insignificant, $F(1, 64) = 1.838$, Sig. 0.180, $p > 0.05$. Table 4.5 shows the mean and SD of teacher presence and the students' level of achievement.

Table 6.4: Mean dan SD of Students' Level of Achievement (upper and lower) and teacher presence (without and without teacher)

Students' Level of Achievement	Teacher presence	Mean	SD	N
--------------------------------	------------------	------	----	---

Lower Level Group	Without teacher	70.2771	2.59934	21
	With teacher	72.9927	4.69714	22
	Total	71.6665	4.01690	43
Upper Level Group	Without teacher	72.8208	1.94153	13
	With teacher	78.0833	4.74558	12
	Total	75.3468	4.40537	25
Total	Without teacher	71.2497	2.65328	34
	With teacher	74.7894	5.25780	34
	Total	73.0196	4.50139	68

Table 6.5 Mean of Students' Level of Achievement and Teacher presence

Students' Level	Mean Teacher presence		N
	Without teacher	With teacher	
Lower	70.2771	72.9927	21
Upper	72.8208	78.0833	13

With reference to Table 6.4, the mean achievement of students in the lower level group without teacher is 70.28 whereas the mean achievement of students in the lower level group with teacher is 72.99. Therefore, the performance of students in the lower level group with teacher is higher than the performance of the students in the lower level group without teacher.

The mean achievement of students in the upper level group without teacher is 72.82 while the mean achievement for students in the upper level group with teacher is 78.08. Therefore, it is shown that the mean achievement of students with teacher is higher than the mean achievement of students without teacher.

The Relationship between Learning Skills and the performance achievement in Science-physics for students without teacher group.

Table 6.1.1 : Correlation between Learning Skills and the performance achievement in Science-physics for students without teacher group.

Variables relationship	r	p
Learning Skills and the performance achievement in Science-physics for students without teacher group.	0.573	0.000

Significant at the level $p \leq 0.05$

Table 6.1.1 showed that the correlation between learning skills and the achievement performance for students without teacher group. The result showed that there is a weak relationship and significance ($r=0.573$, $p=0.0000$) between learning skills and the performance achievement in science-physics for students without teacher group. This means that the learning skill is also a factor that influences the performance achievement in science-physics.

Relationship between Students' Attitudes and Learning Skills and the performance achievement in Science-physics for students without teacher group.

Table 6.1.2: Correlation between Students' Attitudes and the performance achievement in Science-physics for students without teacher group.

Variables relationship	r	p
------------------------	---	---

Students' attitudes and the performance achievement in Science-physics for students without teacher group.	0.299	0.086
--	-------	-------

Significant at the level $p \leq 0.05$

Table 6.1.2 shows the correlation between students' attitudes and performance achievement of students without teacher group. The correlation analysis showed that there is a weak relationship and no significance between students' attitudes and performance achievement of students without teacher group.

Table 6.1.3 : Correlation between Learning Skills and the performance achievement in Science-physics for students with teacher group

Variables relationship	r	p
Learning Skills and the performance achievement in Science-physics for students with teacher group.	0.753	0.000

Significant at the level $p \leq 0.05$

Table 6.1.3 shows the correlation between learning skills and performance achievement for students with teacher group. The correlation analysis showed that there is a strong relationship and significance between learning skills and performance achievement for students with teacher group.

Table 6.1.4 : Correlation between Students' Attitudes and the performance achievement in Science-physics for students with teacher group

Variables relationship	r	p
Students' attitudes and the performance achievement in Science-physics for students with teacher group.	0.653	0.000

Significant at the level $p \leq 0.05$

Table 6.1.4 shows the result from the correlation between students' attitude and the performance achievement for students with teacher group. The correlation analysis showed that there is weak relationship and significance between students' attitude and the performance achievement for students with teacher group in science-physics.

DISCUSSION

The research findings in this study found that performance achievement after CAL is better than the performance achievement before CAL. This finding is also proved by (Qi Chen, 1995) that is, learning using computers can increase teaching and learning quality which at the same time can increase students' performance achievement. This also was claimed by Rusdina (1993) who said that with the existence of certain characteristics which are prepared in teaching with the aid of computers can solve or remedy learning problems that are faced by students.

The findings of this study is also strengthen by a research done by Zamri & Nur Aisyah (2011) which found that teaching and learning using computers increase the cognitive ability and social skills and made learning more conducive and effective for students.

The findings from this study also found that the score performance after CAL is better than the score performance before CAL. This finding is similar to the finding in the research by Irene Cheng (2008), Yahya and Dayang (2011) Chenu, Gayraud, Martinie and Tong (2007) Naba'h, Hussain, Al-Omari, and Shdeifat (2009) that teaching and learning that comes with multimedia can increase students' understanding, can increase score performance and make learning environment more effective from learning through the conventional method.

CONCLUSION

This study has managed to answer all the research questions through the findings. The research findings and discussion found that performance achievement of students with and without teacher groups after CAL is better and CAL has helped in increasing their understanding in science-physics.

REFERENCES

- Annas. (2006). Tekkomdik Nanggro Aceh Darussalam Banda Aceh. *Jurnal Kiprah Pendidikan*, 36(4), 110-128. Dipetik pada 27/2/2007. Dipetik dari <http://www.kiprah.tekkomdicknad.net>.

- Chenu, F., Gayraud, F., Martinie, B., & Wu, T. (2007). Is Computer Assisted Language Learning (CALL) efficient for grammar learning? An experimental study in French as a second language. *The JALT CALL Journal*, 3(3), 85-93.
- Clark, R. E. (1983). Reconsidering research on learning from media. *Rev Educ Res*, 53(4): 445-459.
- Dubinsky, E., & Tall, D. (1991). *Advanced Mathematical Thinking and Computer*. Dalam D. Tall (ed.). *Advanced Mathematics Thinking*. Dordrecht: Kluwer Academic Publishers.
- Irene, C. (2008). Assessing rhythm recognition skills in a multimedia environment. *Educational Technology Journal*, 45 (3), 73-89.
- Naba'h, A. A., Hussain, J., Al-Omari, A., & Shdeifat, S. (2009). The effect of computer assisted language learning in teaching English grammar on the achievement of secondary students in Jordan. *The International Arab Journal of Information Technology*, 6 (4), 431-439.
- Qi, C. (1995). "Effects of learners" character and instructional guidance on computer assisted learning Integrating Information Technology into Education. *Chapman&Hall*, 193-201.
- Rusdina, A, R. (1993). Kearah pengkomputeran pengajaran bahasa: cereka atau fakta. *Dewan Bahasa*, 37(6): 16-30.
- Sharma, R. C. (1983). *Modern Schience Teaching*. New Delhi: Dhanpat Rai & Sons.
- Tabrani. (1994). *Pendekatan dalam Proses Belajar Mengajar*. Jakarta: Remaja Rosdakarya.
- Trowbridges, L. W., & Rodgen, W. B. (1990). *Becoming a Secondary Achool Science Teacher*. Colombus Meril Publisying Company.
- Zamri, M., & Nur, A, M, N. (2011). Persepsi guru tentang penggunaan aplikasi multimedia dalam pengajaran komponen sastra Bahasa Melayu. *GEMA Online Journal of Language Studies*, 11(3), 163-177.
- Zamroni. (2001). *Peran Kolaborasi Sekolah-Universitas dalam meningkatkan Mutu Pendidikan Matematika dan Ilmu Pengetahuan Alam di Indonesia*. Makalah. Disampaikan pada National Seminar on Science and Education. Faculty of Science and Mathematic Education on Colaboration with Japan International Cooperation Agency and Directorate General of Higher Education. Bandung, August 21, 2001.

MADDEYİ TANIYALIM ÜNİTESİNİN ELEŞTİREL DÜŞÜNME YÖNTEMİYLE ÖĞRETİMİNİN ÖĞRENCİLERİN ÜST DÜZEY DÜŞÜNME BECERİLERİNE ETKİSİ

TEACHING LET'S LEARN ABOUT SUBSTANCE UNIT BY CRITICAL THINKING METHOD AND ITS EFFECT ON STUDENTS' HIGH THINKING SKILLS

Öğr. Gör. Bülgen TOMAÇ
Uludağ Üniversitesi
btomac@uludag.edu.tr

Yrd. Doç. Dr. Aslan İLİK
Necmettin Erbakan Üniversitesi
aslanilik42@gmail.com

ÖZET: Bu çalışmada, eleştirel düşünme becerilerini temel alan ilköğretim 4. sınıf Fen ve Teknoloji öğretiminin, öğrenme ürünlerine etkisi incelenmiştir. Araştırmada, deneysel araştırma yöntemi uygulanmıştır. Araştırma 2011-2012 öğretim yılının güz döneminde Konya ili, Selçuklu ilçesi, Özel Konya Bahçeşehir İlköğretim Okulu 4. sınıflarından seçilen iki grup üzerinde yürütülmüştür. Bu gruplar öğretmen, yaş, cinsiyet, bilişsel ve duyuşsal hazırbulunuşluluk değişkenleri açısından birbirine denktir. Gruplardan biri kontrol grubu olarak belirlenirken diğeri deney grubu olarak belirlenmiştir. Kontrol grubunda geleneksel öğretim yöntemi olan düz anlatım kullanılmıştır. Deney grubunda ise eleştirel düşünme becerilerini temel alan Fen ve Teknoloji öğretimi kullanılmıştır. Her iki grupta da dersler laboratuvar ve sınıf ortamında işlenmiştir. Araştırma sürecinin başında her iki gruba da Doç. Dr. Orhan AKINOĞLU tarafından hazırlanan iki test ön-test olarak uygulanmıştır. Bu testler Fen ve Teknoloji Tutum Ölçeği ve Eleştirel Düşünme Becerilerini Temel Alan Fen ve Teknoloji Başarı testidir. Uygulama sonunda aynı testler son-test olarak uygulanmıştır. Ön-test-son-test arasındaki farklarla öğrenci erişileri bulunmuştur. Araştırmanın analizinde SPSS 15.00 paket programı kullanılmıştır. Araştırmada elde edilen sonuçta deney grubunda eleştirel düşünme becerileri ve Fen ve Teknoloji dersine karşı tutumları anlamlı derecede yüksek bulunmuştur. Bu bulgulara dayanarak eleştirel düşünme becerilerini temel alan Fen ve Teknoloji öğretiminin geleneksel anlayıştan daha etkili olduğu söylenebilir.

Anahtar sözcükler: eleştirel düşünme, tutum, fen ve teknoloji, madde

ABSTRACT: In this research, the effects of critical thinking skills on the subject of science taught to 4 th grade students and the contribution to their high level thinking were investigated. In this research experimental searching method has been applied. This survey has been conducted on the chosen two group of 4 th grade students from Private Bahçeşehir Primary School in Konya, Selçuklu District during Fall term 2011-2012 school year. These groups are equal to each other in terms of teacher, age, gender, cognitive and sense level. Determining in the control group and the other one of the group defined as the experimental group. Traditional teaching method used in the control group, a straight narrative. In experimental group, based on critical thinking skills used teaching of Science and Technology. Both group were taught in classroom and laboratory. At the beginning of the survey process two tests that were prepared by Dr. Orhan AKINOĞLU were applied as pre-test. These tests are of critical thinking skills in Science and technology attitude Scale and the basic Science and Technology . The same tests were applied post-test at the end of the application. Differences between pre-test-post-test student achievement was found. SPSS 15.00 package program was used for the analysis of the study. Result obtained in this study, critical thinking skills in the experimental group was significantly higher in their attitudes towards science and technology lesson. Based on these findings, based on critical thinking skills, said to be more effective than the straight narrative method understanding of teaching science and technology.

Key Words: critical thinking, attitude, science and technology, substance

GİRİŞ

Bilgi, günümüz toplumunun hem temel kavramı hem de anahtar gücü konumuna gelmiştir. Endüstri toplumundan bilgi toplumuna geçiş süreci beraberinde güçlü bir toplum olmak için sahip olunması gereken özellikleri de değiştirmiştir. Geçmişte askeri ve ekonomik güç sosyal değişimi kontrol etmek için yeterli

olurken, bugün bilgiye ulaşmayı kontrol eden toplumların sosyal değişimi yaratma gücünü ellerinde tuttukları gözlenmektedir. Bu açıdan bakıldığında, bugün eğitim ve bilgiye ulaşma askeri ve ekonomik güce sahip olma ile aynı önemi taşımaktadır.

Bilgi çağının anahtar kavramı "küreselleşme" yeni eğilimleri ve kavramları da beraberinde getirmektedir. Bu kavramlardan biri de "çoklu tercihtir". Bir işi başarmak için tek ve doğru bir yol yoktur. Başarılı bir sonuca ulaşmak için çok sayıdaki seçeneğin bir arada tümleşik bir biçimde göz önüne alınması ve kullanılabilmesi gerekmektedir. Bu duruma ilişkin en çarpıcı örnek yazılı ve görsel medyadır. Geçmişte bilgi sadece kitap, gazete, tek kanallı radyo ve televizyon aracılığıyla bireylere ulaştırılırken, günümüzde bilgi, çok sayıda radyo ve televizyon kanalı ve uluslararası bilgi ağı ile bireylere ulaştırılmaya çalışılmaktadır. Çoklu tercihler yaratan bilgi kaynakları, bireylerin bilgi toplumunun bilgi işleme, iletişim becerileri ve güvenilir olma gibi üç kritik özeliği ile donanmış olmalarını gerektirmektedir. Bu bağlamda, eğer eğitim programları öğrencilerin bu becerilerinin gelişmelerine olanak sağlayan hedef, içerik ve eğitim durumlarından yoksun ise, yirmi birinci yüzyılın başarılı bilgi toplumunu yaratmada yetersiz kalınacağı söylenebilir. Yirminci yüzyıl süresince sınıf içi uygulamaları temel alan araştırmalar, sunuş ve ezber yöntemlerinin baskın olduğunu tutarlı bir biçimde belgelemektedir. Bu tür bir sınıf ortamında öğrenciler edilgen olarak bilgiyi alır ve sadece basit düzeyde hatırlama ve kavrama gerektiren öğretmen sorularını yanıtlarlar (Onosko, 1988:1, Aktaran: Şahinel, 2002). Sınıf ortamına ilişkin elde edilen araştırma bulguları, çağdaş yaşamın karmaşıklığında başarılı olmak için gerekli olan düşünme becerilerinin öğrencilere kazandırılmadığını ortaya koymaktadır. Bu durum doğal olarak işverenlerin, eğitimcilerin ve üst düzey devlet yöneticilerin dikkatlerinin eleştirel düşünme becerileri üzerinde yoğunlaşmasına neden olmaktadır.

Eğitim sistemimiz 2004 öncesinde düşünme becerileri yeterli önem vermemekte idi. Ancak 2004 yılından sonra uygulamaya konulan yapılandırmacı yaklaşım ile bu yıkılmaya çalışılsa da tam olarak istenilen düşünme yeteneğine sahip bireyler yetiştirilmesinde güçlük yaşanmaktadır. Eğer çok boyutlu düşünmeyi eğitim sistemimize en iyi şekilde adapte edersek bilim dünyasında sözü geçen nesillere en kısa sürede ulaşmak mümkün olabilir. İçinde bulunduğumuz bilgi çağında asıl amaç düşünmeyi bilen öğrenciler yetiştirmektir. Bunun için öğretmenin anlatan öğrencinin pasif alıcı olduğu sınıflar yerine, öğrencinin düşünme becerileri ile aktif katılımının olduğu sınıflar yaratılmalıdır. Bu bağlamda düşünüldüğünde öğrenci bilgiyi işleme sürecine aktif olarak katılmalıdır. Bilgiyi pasif olarak dinleyerek alan bir öğrenci kavrama ve uygulama basamaklarında sıkıntı yaşamaktadır. Bilgiyi transfer edememektedir. Oysa eleştirel düşünme becerilerini kazanmış bir öğrenci bilgiyi rahatlıkla transfer eder, uygular ve değerlendirir. Eleştirel düşünme becerilerini kazanmış bir öğrenci üretken, verimli, aktif, sosyal, iyi düşünüp doğru karar verebilir ve hatta öğrenme sorumluluğunu alabilir. Eleştirel düşünen bireyler olaylara 'Neden?', 'Niçin?', 'Nasıl oldu?', 'Sonuçları neler olabilir?' sorularını sorar. Kendisinin ve yaşadığı çevrenin farkına varır. Kendini sürecin içine dahil eder. Öğretimin özü düşünme becerilerini kazandırma olmalıdır (Özden, 2000:92). Bu nedenle Fen ve Teknoloji öğretimi alanında öğrencilerin tutum özellikleri, eleştirel düşünme becerileri, erişim düzeyleri üzerinde durulması gerekmektedir.

Eleştirel düşünme becerilerini temel alan İlköğretim 4. sınıf Fen ve Teknoloji dersi 'Maddeyi Tanıyalım' ünitesinin öğretiminin uygulandığı grubun (deney grubu), düz anlatım ve laboratuvar uygulamalarını temel alan İlköğretim 4. sınıf Fen ve Teknoloji öğretiminin uygulandığı grubun (kontrol grubu) eleştirel düşünme becerileri testinden aldıkları puanlar arasında ve deney ve kontrol gruplarının tutum ölçeğinden almış oldukları puanlar arasında anlamlı bir fark var mıdır? araştırmanın problem cümlesi olarak belirlenmiştir.

Fen ve Teknoloji; doğa bilimlerinden yararlanarak, öğrencilere yaşadıkları fiziksel çevredeki varlıkların özellikleri ve birbirleri ile olan ilişkileri, üzerinde temel bilgi ve anlayışları kazandırma hedefi güden bir ders olarak tanımlanabilir (Akınoğlu, 2001:14). Fennin amacı doğal dünyayı anlayarak açıklamaya çalışmak; teknolojinin amacı ise insanların istek ve ihtiyaçlarını karşılamak için doğal dünyada değişiklikler yapmaktır (MEB, 2005). Aristoteles'e göre düşünme, insanı hayvandan ayıran belirgin bir özneliktir, usun bağımsız ve kendine özgü eylemidir, karşılaştırmalar yapma, ayırma, birleştirme, bağlantıları ve biçimleri kavrama yetişidir. Düşünme ve eğitim ilişkisini incelediğimizde; öğretim düşünmeyi öğretmeye yönelik olarak düzenlenmeli, düşünce becerilerini geliştirici programlar tasarlanmalı, düşünme için öğretme ve düşünmeyi düşünme temel alınmalıdır. Uzmanlar eğitimin her kademesinde öğrencilere zeka ve yetenekleri doğrultusunda düşünme becerilerinin kazandırabileceğini belirtmektedirler. Eleştirel düşünme; tenkitçi, değerlendirmeci, şüpheli, analitik, açık, dikkatli, mantıksal ve bağımsız düşünme anlamlarında kullanılmakta (Şahinel, 2002:3) ve değerlendirme, problem çözme süreci ve entelektüel gelişme süreci olarak tanımlanmaktadır (Gibson 1995:27). Bir başka ifadeyle eleştirel düşünme; çıkarımda bulunarak, sorgulayarak, araştırarak, görüşleri yargılayarak, ilişki kurarak, bilinçli bir şekilde ön öğrenmeleri değiştirmek için kullanılan zihinsel süreçlerden problem çözme yeteneğidir (Tomaç, 2012:15).

Beyer (1991:124)'e göre iyi yetkin düşünen bireyler; bir sorunu, problemi veya iddiayı açık bir biçimde ifade eder, diğer bireylerin kesin bir dil kullanmasını, düşünülmeden hareket edilmemesini, çalışmaların kontrol edilmesini ister, bir düşüncüyü oluşturmada azimli olunması, öne sürülen iddiaları destekleyen nedenleri ve kanıtları araştırma ve sunmayı isterken, daha çok dogmalar ve özlem duyulan düşünceler yardımıyla değil, sorunlar, amaçlar ve sonuçlar yardımıyla yargılama, ön bilgileri kullanma, yeterli kanıt bulana kadar yargıdan şüphe duyma eğilimi içindedir. Onosko (1991) ise eleştirel düşünmenin önündeki engelleri şu şekilde belirtmiştir: öğretimin bilgi transferi olarak tanımlanması, içeriğin çok yüzeysel ve geniş olması, öğretmenlerin öğrencilerden düşük beklentisi, sınıfların kalabalık olması, öğretmenin zamanı planlayamaması, öğretmenin izole olması, öğrencilerin sadece pasif bilgi alıcı rolünde olması, öğretmenin sadece bilgiyi dağıtan rolünde olması, öğrencilerin bilgileri hatırlamak ve sorulduğunda söylemek-yazmak zorunda olmaları, öğrencilere verilen problemlerin her zaman açık biçimde formüle edilmemesi. Mckee'ye (1998) göre ise eleştirel düşünmenin önündeki engeller şunlardır: eleştirel düşünme eğitiminin değişen öğretmen tutum ve davranışlarını gerektirmesi, öğrenciler arasındaki bireysel farklılıkları azaltma yönünde olan öğretmen davranışları, öğretmenlerin öğrenme süreci ve öğrenciler üzerinde tam kontrole sahip olmaları gerektiğine inanmaları, öğretmenlerin kendilerini konu alanı uzmanı olarak görmeleri, diğer disiplinlerden yalıtılmış biçimde kendi alanlarıyla ilgilenme eğiliminde olmaları, öğretim programlarının yoğunluğu. Glaser'e göre bütün öğretmenler eğitim programları aracılığıyla eleştirel düşünmeyi öğretmelidirler. Eğitim, çocuklar için felsefe ve özgür toplumun doğasını birleştirecek, uzmanlar tarafından dikkatlice tasarılacak programlar aracılığıyla ilköğretim ilk yıllarından başlayarak eleştirel düşünme becerilerini geliştirme amacını taşımaktadır. Böylece öğrencilere mantıksal düşünmenin temel ilkeleri başarıyla öğretilir. eleştirel düşünebilmek için gerekli bilişsel ve duyuşsal becerilerin tamamı çocuklarda okuma ve dinleme kapasiteleri aracılığıyla zaman içinde köklü bir biçimde geliştirilmelidir (Aktaran: Şahinel, 2002: 15-16).

Tüm bunlardan yola çıkarak nihai amacımızın düşünmeyi ve düşünme türlerini öğretmemiz olduğu aşıkardığı söylemek doğru olacaktır. Aslına bakılırsa, eğitim sistemi, bireyde kalıplaşmış davranış, ezbere dayalı ve dayatılmış bilgiler yerine; yaratıcı ve eleştirel düşünme becerilerine dayalı öğrenmelere olanak veren, öğrendiklerini yorumlayabilen ve düşüncelerinde tarafsız olan bireyler yetiştirme temeline dayanmalıdır. Fen eğitiminde konuyla ilgili yapılan araştırmalar tarandığında ise ortaya çıkan sonuçta eleştirel düşünmenin öğretimde etkili bir rol oynadığı yönündedir.

YÖNTEM

Çalışmada deneysel araştırma yöntemi kullanılmıştır. Çalışmada “denk kontrol gruplu ön-test-son-test deseni” kullanılmıştır. Bu yöntemde deney ve kontrol grupları rastgele belirlenmiştir. Araştırmada öğrencilerin Fen ve Teknoloji dersine yönelik tutumlarını ölçmek için Akınoğlu (2001) tarafından geliştirilen ‘Fen ve Teknoloji Tutum Ölçeği’ ve Akınoğlu (2001) tarafından hazırlanan ‘Maddeyi Tanıyalım Ünitesi Eleştirel Düşünme Becerileri Ölçme Aracı’ kullanılmıştır. Uygulama öncesinde grupların ikisine de Fen ve Teknoloji dersine yönelik tutum ölçeği ve eleştirel düşünme becerilerini ölçmeye yarayan başarı testi ön-test olarak uygulanmıştır. Uygulanan testler SPSS (Statistical Package for Social Science) paket programı ile analiz edilecek grupların erişti ortalamaları arasında farklılığın olup olmadığı incelenmiştir. Deney grubuna “Maddeyi Tanıyalım” ünitesindeki konular eleştirel düşünme becerilerini temel alan fen öğretimi ile anlatılırken, kontrol grubuna geleneksel fen öğretimi ile anlatılmıştır. Ünitenin öğretiminin sonunda her iki gruba da ön-test olarak uygulanan testler son-test olarak uygulanmıştır. Uygulamanın ardından test sonuçları SPSS paket programı yardımıyla analiz edilerek aralarında anlamlı bir fark olup olmadığı incelenmiştir.

Araştırmanın evreni, Konya ili, Selçuklu ilçesi, Özel Konya Bahçeşehir İlköğretim Okulu'nda okuyan tüm öğrenciler olup örneklemini 2011-2012 öğretim yılı birinci döneminde Konya ili Selçuklu ilçesi Özel Konya Bahçeşehir İlköğretim Okulu'nda okuyan iki sınıf arasından rastgele belirlenmiştir. Örnekleme ilişkin veriler Tablo 1. 'de gösterilmiştir.

Tablo 1. Örnekleme İlişkin Veriler

Gruplar	Kız öğrenci sayısı	Erkek öğrenci sayısı	Toplam
Kontrol Grubu	7	10	17
Deney Grubu	8	10	18
Toplam	15	20	35

BULGULAR

Grupların eleştirel düşünme becerilerini ölçmeye yönelik hazırlanan başarı testi ve tutum ölçeğine ait veriler Bağımsız t testi kullanılarak karşılaştırılmıştır. Ayrıca grupların almış oldukları puanların yüzdeleri Bar analizi

yapılarak Grafiklere dönüştürülmüştür. Bağımsız t testi sonuçları Levene istatistiğinin sonucuna göre yorumlanmıştır. Levene istatistiği ve Bağımsız t testine ait P değerlerinin karıştırılmaması için sırasıyla Levene istatistiği için P_1 , Bağımsız t testi için P_2 kullanılmıştır.

Başarı Testi

Ön Test

Deney ve kontrol grubu öğrencilerinin uygulama öncesinde ön-test olarak uygulanan başarı testine ait veriler Tablo 2. ve Tablo 3. 'de verilmiştir.

Tablo 2. Grupların Ön-test Sonuçlarından Elde Edilen Ortalama Puanları

	Gruplar	N	Ortalama Puanlar	Standart Sapma
Başarı	Deney	18	18,2222	9,23265
	Kontrol	17	20,3529	17,17535

Tablo 2.'ye göre; deney grubunun ön-test ortalaması 18,2222 iken kontrol grubunun ön-test ortalaması 20,3529 olarak bulunmuştur. Deney ve kontrol grubu öğrencilerinin uygulama öncesinde eleştirel düşünme becerileri arasındaki ilişkiyi ortaya koymak için Bağımsız t testi uygulanmıştır. Elde edilen veriler Tablo 3. 'te verilmiştir.

Tablo 3. Grupların Ön-test Sonuçlarından Elde Edilen Ortalama Puanlarının Karşılaştırıldığı t Testi Sonucu

	Levene İstatistiği		t testi			
	F	P_1	t	Sd	P_2	Anlam farkı
Başarı	10,906	0,002	-0,453	24,227	0,654	-2,13072

Tablo 3. 'de de görüldüğü üzere Levene istatistiğine göre grupların varyanslarının eşit olmadığı bulunmuştur ($P_1 < 0,05$). Buna göre yapılan t testi sonucu grupların eleştirel düşünme becerilerine ait ortalama puanları arasında anlamlı bir farklılık bulunmamıştır ($t_{24,227} = -0,453$; $P_2 > 0,05$). Bu sonuca göre her iki grup uygulama öncesinde eleştirel düşünme becerileri açısından eşit düzeyde denilebilir.

Son Test

Deney ve kontrol grubu öğrencilerinin uygulama sonrasında son-test olarak uygulanan başarı testine ait veriler Tablo 4., Tablo 5. ve Şekil 1.'de verilmiştir.

Tablo 4. Grupların Son-test Sonuçlarından Elde Edilen Ortalama Puanları

	Gruplar	N	Ortalama Puanlar	Standart Sapma
Başarı	Deney	18	122,1667	30,48095
	Kontrol	17	91,4706	16,50045

Tablo 4.'e göre; deney grubunun son-test ortalaması 122,1667 iken kontrol grubunun son-test ortalaması 91,4706 olarak bulunmuştur. Deney ve kontrol grubu öğrencilerinin uygulama sonrasında eleştirel düşünme becerileri arasındaki ilişkiyi ortaya koymak için Bağımsız t testi uygulanmıştır. Elde edilen veriler Tablo 5.'te verilmiştir.

Tablo 5. Grupların Son-test Sonuçlarından Elde Edilen Ortalama Puanlarının Karşılaştırıldığı t Testi Sonucu

	Levene İstatistiği		t testi			
	F	P_1	t	Sd	P_2	Anlam farkı
Başarı	7,904	0,008	3,733	26,478	0,001	30,69608

Tablo 5.'te de görüldüğü üzere Levene istatistiğine göre grupların varyanslarının eşit olmadığı bulunmuştur ($P_1 < 0,05$). Buna göre yapılan t testi sonucu grupların eleştirel düşünme becerilerine ait ortalama puanları arasında anlamlı bir farklılık bulunmuştur ($t_{26,478} = 3,733$; $P_2 < 0,05$). Bu sonuca göre deney grubu öğrencileri kontrol grubu öğrencilerinden oldukça başarılıdır denilebilir.

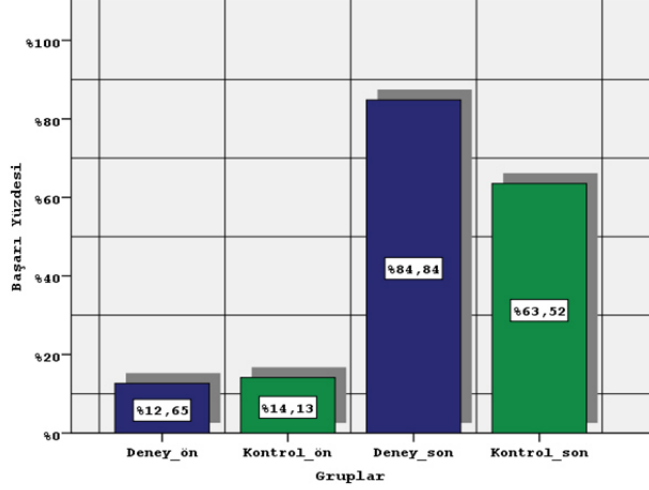

Şekil 1. Grupların Ön-test ve Son-test Başarı Yüzdesi

Şekil 1.'den de anlaşılacağı üzere deney grubu öğrencilerinin ön-test sonuçlarının başarı yüzdesi %12,65 ve kontrol grubu öğrencilerinin son-test sonuçlarının başarı yüzdesi %14,13 idi. Deney grubu öğrencilerinin son-test sonuçlarının başarı yüzdesi % 84,84 ve kontrol grubu öğrencilerinin son-test sonuçlarının başarı yüzdesi % 63,52 olarak bulunmuştur. Bu sonuca göre de deney grubu öğrencileri kontrol grubu öğrencilerinden oldukça başarılı olduğu söylenir.

Tutum Ölçeği

Ön Test

Deney ve kontrol grubu öğrencilerinin uygulama öncesinde ön-test olarak uygulanan tutum ölçeğine ait veriler Tablo 6. ve Tablo 7. 'de verilmiştir.

Gruplar	N	Ortalama Puanlar	Standart Sapma
Deneysel	18	64,1667	13,36919
Kontrol	17	62,1176	14,77279

Tablo 6.'ya göre; deney grubunun ön-test ortalaması 64,1667 iken kontrol grubunun ön-test ortalaması 62,1176 olarak bulunmuştur. Deney ve kontrol grubu öğrencilerinin uygulama öncesinde Fen ve Teknoloji dersine karşı tutumları arasındaki ilişkiyi ortaya koymak için Bağımsız t testi uygulanmıştır. Elde edilen veriler Tablo 7. 'de verilmiştir.

Tablo 7. Grupların Ön-test Sonuçlarından Elde Edilen Ortalama Puanlarının Karşılaştırıldığı t Testi Sonucu

	Levene İstatistiği		t testi			
	F	P ₁	T	Sd	P ₂	Anlam farkı
Tutum	0,092	0,764	0,431	33	0,669	2,04902

Tablo 7.'de de görüldüğü üzere Levene istatistiğine göre grupların varyanslarının eşit olduğu görülmektedir ($P_1 > 0,05$). Buna göre yapılan Bağımsız t testi sonucu grupların Fen ve Teknoloji dersine yönelik tutumları arasında anlamlı bir farklılık çıkmamıştır ($t_{33} = 0,431$; $P_2 > 0,05$). Bu durumda deney grubu öğrencileri ile kontrol grubu öğrencilerinin Fen ve Teknoloji dersine karşı tutumları arasında bir fark yoktur. Yani gruplar uygulamaya eşit düzeyde başlamışlardır denilebilir.

Son Test

Deney ve kontrol grubu öğrencilerinin uygulama sonrasında son-test olarak uygulanan tutum ölçeğine ait veriler Tablo 8., Tablo 9. ve Şekil 2' de verilmiştir.

Gruplar	N	Ortalama Puanlar	Standart Sapma	
Tutum	Deney	18	78,5556	12,69656
	Kontrol	17	68,6471	13,63333

Tablo 8.' e göre; deney grubunun son-test ortalaması 78,5556 iken kontrol grubunun son-test ortalaması 68,6471 olarak bulunmuştur. Deney ve kontrol grubu öğrencilerinin uygulama sonrasında Fen ve Teknoloji dersine karşı tutumları arasındaki ilişkiyi ortaya koymak için Bağımsız t testi uygulanmıştır. Elde edilen veriler Tablo 9. ' da verilmiştir.

Tablo 9. Grupların Son-test Sonuçlarından Elde Edilen Ortalama Puanlarının Karşılaştırıldığı t Testi Sonucu

	Levene İstatistiği		t testi			
	F	P ₁	t	Sd	P ₂	Anlam farkı
Tutum	0,118	0,733	2,226	33	0,033	9,90850

Tablo 9.'da da görüldüğü üzere Levene istatistiğine göre grupların varyanslarının eşit olduğu görülmektedir ($P_1 > 0.05$). Buna göre yapılan Bağımsız t testi sonucu grupların Fen ve Teknoloji dersine yönelik tutumları arasında anlamlı bir farklılık çıkmıştır ($t_{33} = 2.226$; $P_2 < 0,05$). Bu durumda deney grubu öğrencileri ile kontrol grubu öğrencilerinin Fen ve Teknoloji dersine karşı tutumları arasında uygulama sonrasında anlamlı bir fark belirlenmiştir. Yani gruplar uygulama sonunda Fen ve Teknoloji dersine karşı tutumları değişmiştir.

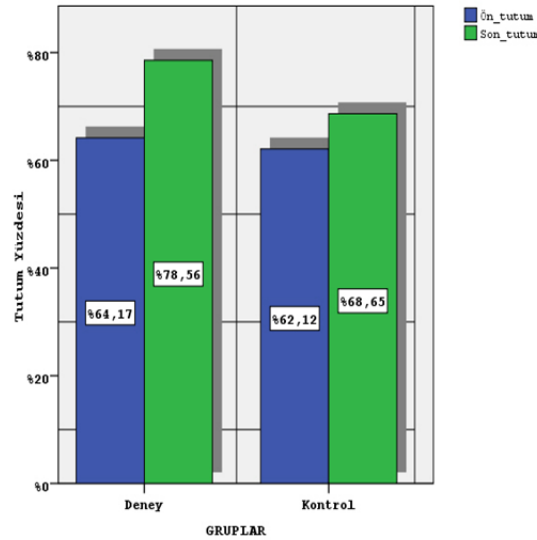

Şekil 2. Grupların Ön-test ve Son-test Tutum yüzdesi

Şekil 2.'den de anlaşılacağı üzere deney grubu öğrencilerinin ön-test sonuçlarının tutum yüzdesi %64,17 ve kontrol grubu öğrencilerinin ön-test sonuçlarının tutum yüzdesi %62,12 idi. Deney grubu öğrencilerinin son-test sonuçlarının tutum yüzdesi % 78,56 ve kontrol grubu öğrencilerinin son-test sonuçlarının tutum yüzdesi % 68,65 olarak bulunmuştur.

Araştırmanın bulguları doğrultusunda yapılan değerlendirme neticesinde aşağıdaki sonuçlara ulaşılmıştır:

- 1- Deney ve kontrol grubu öğrencileri uygulama öncesinde başarı yönünden eşit düzeydedirler.
- 2- Deney grubu öğrencileri uygulama sonunda kontrol grubu öğrencilerinden daha başarılı olmuşlardır. Eleştirel düşünme becerilerini temel alan Fen ve Teknoloji öğretiminin öğrencilerin üst düzey düşünme becerilerini arttırdığı ortaya çıkmıştır.
- 3- Uygulama öncesinde deney ve kontrol grubu öğrencilerinin Fen ve Teknoloji dersine yönelik tutumları açısından eşit düzeydedirler.
- 4- Deney grubu öğrencilerinin uygulama sonunda kontrol grubu öğrencilerine göre Fen ve Teknoloji dersine yönelik tutumlarındaki olumlu artışı daha fazla olmuştur. Bu durum eleştirel düşünme becerilerini temel alan Fen ve Teknoloji öğretiminin öğrencilerin Fen ve Teknoloji dersine yönelik tutumlarını arttırdığı ortaya çıkmıştır.

5- Uygulama sonunda deney grubu öğrencilerinin kontrol grubu öğrencilerinden daha başarılı olmasında eleştirel düşünme becerilerini temel alan Fen ve Teknoloji öğretiminin etkisi vardır.

ÖNERİLER

Yapılmış olan bu araştırmanın bulguları ve sonuçları doğrultusunda şu önerilerde bulunulmuştur.

1- Eleştirel düşünme becerilerini temel alan yöntem ile ders anlatılmadan önce öğrenciler bu konu hakkında bilgilendirilmelidir.

2- Eleştirel düşünme becerilerini temel alan yöntem ile ders işlenmesi konusunda uygulayıcıların bilgilendirilmesi için hizmet içi eğitim seminerleri düzenlenebilir.

3- Öğretmen eleştirel düşünme becerilerini temel alan yöntem ile ders işlemeden önce bir plan hazırlamalıdır.

4- Öğrencilerin görüşleri sabırla dinlenmelidir.

5- Sınıf içi ve laboratuvar ortamı öğrencilerin rahat çalışmasını sağlayacak şekilde düzenlenmelidir.

6- Günümüz eğitim sisteminde eleştirel düşünme ile ilgili sorulara zaman zaman yer verilmektedir.

Ama bu soruların artırılması sadece fen bilimleri anlamak için değil hayattaki sorunların çözümü içinde önemli olabilir.

Not: Bu çalışma Bülgen TOMAÇ'ın 'Maddeyi Tanıyalım Ünitesinin Eleştirel Düşünme Yöntemiyle Öğretiminin Öğrencilerin Üst Düzey Düşünme Becerilerine Etkisi' isimli tez çalışmasından üretilmiştir.

KAYNAKLAR

1. Akınoğlu, O. (2001). Eleştirel Düşünme Becerilerini Temel Alan Fen Bilgisi Öğretiminin Öğrenme Ürünlerine Etkisi. Doktora Tezi, Hacettepe Üniversitesi, Sosyal Bilimler Enstitüsü, Ankara.
2. Beyer, K. B. (1998). Developing a Scope and Sequence for Thinking Skills Instruction. Educational Leadership.
3. Gibson, C. (1995). Critical Thinking: Implacitions for Instrauction. RQ, 35 no1
4. Mckee, J. S. (1988). Impediments to Implementing Critical Thinking. Social Education.
5. MEB (2005). İlköğretim Fen ve Teknoloji Dersi (4. ve 5. sınıflar) Öğretim Programı ve Kılavuzu, Ankara.
6. Onosko, J. J. (1991). Barriers to the promotion of Higher-Order Thinking. Theory and Research in Higher Education.
7. Özden, Y. (2000). Öğrenme ve Öğretme. Ankara: Pegem A Yayıncılık.
8. Şahinel , S. (2002). Eleştirel Düşünme (1. Baskı). Ankara: Pegem A Yayıncılık.
9. Tomaç, B. (2012). Maddeyi Tanıyalım Ünitesinin Eleştirel Düşünme Yöntemiyle Öğretiminin Öğrencilerin Üst Düzey Düşünme Becerilerine Etkisi. Yüksek Lisans Tezi, Necmettin Erbakan Üniversitesi, Eğitim Bilimleri Enstitüsü, Konya.

8. SINIF ÖĞRENCİLERİNİN RUTİN OLMAYAN PROBLEMLER KARŞISINDA KULLANDIKLARI STRATEJİLER

EIGHTH GRADE STUDENTS' STRATEGIES TO SOLVE NONROUTINE MATHEMATICS PROBLEMS

Alattin URAL

Mehmet akif Ersoy üniversitesi, Eğitim Fakültesi, İlköğretim Bölümü, Matematik Eğitimi Anabilim Dalı
ural@mehmetakif.edu.tr

ÖZET: Bu çalışmanın amacı; sekizinci sınıf öğrencilerinin rutin olmayan matematik problemlerini çözerken kullandıkları stratejileri ve başarılarını lisede seçmeyi düşündükleri alanlar temelinde incelemektir. Çalışma üç sınıftan toplam 57 öğrenci katılmıştır. Öğrencilere 11 soruluk açık uçlu bir sınav uygulanmıştır. Sayısal bölüm düşünenlerin doğru yanıt ortalamaları (5.03) ile eşit ağırlık (1.53) ya da sözel alan düşünenlerin puanları (1.25) arasındaki fark istatistiksel olarak anlamlı bulunmuştur. Bu puanlar öğrencilerin rutin olmayan problemleri çözebilmede yetersiz olduğunu göstermektedir. Sayısal öğrenciler kullanılan tüm stratejilerin % 69' unu, eşit ağırlıkçılar % 24' ünü ve sözelciler de % 7' sini kullanmıştır. Tahmin ve kontrol stratejisi %43, şekil çizme %24, eşitlik yazma %15, sistematik liste yapma %6, geriye doğru çalışma %6, bağıntı arama %4 ve problemi basitleştirme %3 oranında kullanılmıştır. Sayısal öğrenciler genelde tahmin-kontrol, şekil çizme ve eşitlik yazma stratejilerini; eşit ağırlıkçılar tahmin-kontrol ve şekil çizme stratejilerini; sözelciler ise sadece tahmin-kontrol stratejisini kullanmıştır. Problemi basitleştirme ve geriye doğru çalışma stratejileri sadece sayısal öğrenciler tarafından kullanılmıştır.

Anahtar sözcükler: problem çözme stratejileri, rutin olmayan matematik problemleri

ABSTRACT: The aim of this research is to investigate 8th grade students' strategies to solve nonroutine mathematics problems, and their achievements on the basis of the divisions that they consider to select for high school. The participants are 57 students from 3 classes. 11 problems were asked to the students. Science-math, Turkish-mathematics and social sciences students averagely solved 5.03, 1.53 and 1.25 problem respectively. The differences between the Science-math students' average scores and the others were statistically meaningful. The science-math, Turkish-math and social sciences students used 69%, 24%, 7% respectively of all the strategies used. "Guess-check (GC)" (43%), "drawing a diagram (DD)" (24%), "writing an equation (WE)" (15%), "making an organized list (ML)" (6%), "working backwards (WB)" (6%), "looking for a pattern (LP)" (4%), "solving a simpler problem (SS)" (3%) are the strategies used. Science-math students generally used GC, DD, WE; Turkish-mathematics students used GC, DD; social-sciences students used only GC. SS and WB were used by only science-math students.

Key words: problem solving strategies, nonroutine mathematics problems

GİRİŞ

Matematik eğitiminin amaçlarından biri de öğrencilere problem çözme becerisini öğretmektir. Matematik derslerinde problem çözmenin önemi üzerine çok sayıda araştırma vardır (Ford, 1994; Higgins, 1997; NCTM, 1989; Verschaffel, De Corte, Lasure, Van Vaerenbergh, Bogaert, Ratinckx, 1999). Problem çözme, istenilen hedefe varabilmek için etkili ve yararlı olan araç ve davranışları türlü olanaklar arasından seçme ve kullanmaktır (Demirel, 2005). Problem çözme, varolan bilgileri yeni problemlere uygulama sürecidir. Problem çözme bilimsel bir yöntem olduğundan, eleştirel düşünmeyi, yaratıcı ve yansıtıcı düşünmeyi, analiz ve sentezleme becerilerinin de kullanımını gerektirebilir.

Problem çözme başarısını etkileyen faktörler genel olarak üç başlık altında ele alınmaktadır. Bunlar; bilişsel, duyuşsal ve tecrübe faktörleridir (Van de Walle, 2004; Baykul, 2005). Bilişsel faktörler açısından, Mayer (1982) problem çözümünde bireyin dört bilgi türüne sahip olması gerektiğini belirtmiştir. Bunlar: Anlam bilgisi, Şematik bilgi, Algoritmik bilgi, Stratejik bilgi'dir. Anlam bilgisi; öğrencinin problemde yer alan bilgileri anlam bilgisini kullanarak matematiksel ifadelerle dönüştürebilmesidir. Şematik bilgi; öğrencinin problemdeki bilgi yapılarını benzer problem türü veya şemalarıyla ilişkilendirerek anlamlı bir bütün haline getirebilmesidir. Araştırmalara göre, problem çözme sürecinde şematik bilginin çeşitliliği ve gelişmişliği çözüme yarı otomatik olarak ulaşılabilmesini sağlamaktadır (Geiger&Galbraith, 1998). Algoritmik bilgi; oluşturulan denklem,

eşitsizlik gibi matematiksel ifadelerin çözülebilesidir. Stratejik bilgi; öğrencinin çözüm sürecinde kullanabileceği bazı tekniklerdir. Duyuşsal faktörler ise, problem çözmeye ilgi, istek, kendine güven, kaygı, kararlılık gibi etmenlerdir.

Rutin problemler, günlük hayatta karşılaşılan ve çözümesinde dört işlem becerilerinin yeterli olduğu, çocukların günlük hayatta gerekli işlem becerilerini geliştirmeleri ve problemde geçen bilgileri matematiksel olarak ifade etmeyi öğrenmeleri için önemli problemlerdir. Matematik ders kitaplarında yer alan ve dört işlem becerileri ile çözülebilen problemlerdir. Orton ve Frobisher'e (1997) göre hedefe ulaşmak için başlangıçta bilinen ya da anımsama olasılığı olan matematiksel bir yöntemi olmamasından dolayı rutin problemler gerçek anlamda problem olarak düşünülmez. Alıştırmanın tanımı, öğrenilmiş bir olgunun ya da becerinin doğrudan uygulaması olduğuna göre, bu tip problemlere alıştırmaya denebilir. Rutin olmayan problemler rutin olanlara göre daha fazla düşünme gerektiren, çözmek için yöntemin açık olarak gözükmediği problemlerdir (Polya, 1957). Rutin olmayan problemlerin çözümleri işlem becerilerinin ötesinde, verileri organize etme, sınıflandırma, ilişkileri görme gibi becerilere sahip olmayı ve bir takım aktiviteleri arka arkaya yapmayı gerektirir (Souviney, 1989). İyi yapılandırılmamış problemlerin çözümlerinin amacı, problem çözümlerinin mantığını ve doğasını kavrama, bir problemle karşılaşıldığında uygun stratejiyi seçme, kullanma ve sonuçları yorumlama yeteneklerini geliştirmektir (Yaman, 2003).

Rutin olmayan problemlerde çeşitli çözümler yapmak, stratejiler kullanmak mümkündür. Aynı zamanda öğrencilere gerçek bir bağlamda uygulama, analiz, sentez gibi daha ileri düşünme becerilerini kullanma fırsatı sunar. Oregon Department of Education (1991) tarafından tanımlanan rutin olmayan problemleri anlama şunları içerir (Akt. Rina, Auxencia & Rene, 2011):

a) Kavramsal anlamıyla birlikte, problemi yorumlama, uygun kavramları ve çözüme yönelik stratejiyi seçme becerisi. Problem durumu, ilgili bilgi, uygun matematiksel kavramlar ve mantıksal yanıtlar arasında ilişki kurma becerisi.

b) Prosedürel bilgiyi kullanabilme becerisi.

c) İyi bir muhakeme ve sezgisel düşünme becerisi.

Devlin (2007) kavramsal anlamayı, matematiksel kavramları, işlemleri ve ilişkileri kavrama olarak tanımlamıştır. Ben-Hur (2006) prosedürel bilgiyi formal dil veya sembolik temsiller bilgisi olarak tanımlamıştır.

Birçok araştırmada öğrencilerin özellikle rutin olmayan problemleri ele almada yetersiz oldukları gösterilmiştir (Asman & Markowitz, 2001; Higgins, 1997; Holton & Anderson, 1999). Bu durum iki temel nedene bağlanabilir: Alan bilgisi ve becerisindeki yetersizlik (kavramlar, formüller, çözüm yöntemi bilgisi, problem çözme), yaratıcı düşünme, bilişüstü becerilerde eksiklikler ve duyuşsal faktörlerdeki olumsuzluklar. Öğrenciler rutin olmayan problemlerle karşılaştıklarında çoğunlukla problem çözme stratejileri üzerinde düşünmek yerine verilen sayılarla ilgili bir işlem yapmaya eğilimi göstermektedir (Arslan ve Altun, 2007).

Problem çözme öğretimi ve onun nasıl geliştirilebileceği konusunda pek çok araştırma vardır (Ford, 1994; Verschaffel & De Corte, 1997; Higgins, 1997; Verschaffel ve diğ., 1999; Holton & Anderson, 1999; Follmer, 2000; Asman & Markowitz, 2001; Pugalee, 2001; Niederer & Irwin, 2001; Altun & Arslan, 2006; Arslan & Altun, 2007; Yazgan, 2007). Öğrencilerin problem çözme becerilerini geliştirmek için, öğretmenler bu stratejileri rutin olmayan problem durumlarında göstermelidir (Rina, Auxencia & Rene, 2011). Problem çözme öğrencilerin gerçek yaşam açısından kazanması gereken temel bir beceri olarak görülür (Krulik & Rudnick, 1996). Yaratıcı ve analitik düşünmenin yanında öğrencilerde kavramsal anlamayı ve matematiğin anlamını öğrenmelerine destek olur. Problem çözme becerisinin kazanılması uzun bir süreci kapsar ve programlı bir çalışma gerektirir. Öğrencilerin problem çözme becerilerinin yetersizliğinde öğretim yöntemleri de kuşkusuz önemli bir nedendir. Öğretim biçiminde yer alan bu yetersizlikler de iki başlık altında toplanabilir: Öğretimde kullanılan problemlerin türleri: Okullarda öğrenciler çoğunlukla sıradan problemlerle karşılaşması ve problem çözme öğretiminde kullanılan yöntem ve sınıf kültürü (Altun, 2006).

YÖNTEM

Araştırmanın Amacı

Bu çalışmanın amacı, sekizinci sınıf öğrencilerinin rutin olmayan matematik problemlerini çözerken kullandıkları stratejileri ve başarılarını lisede seçmeyi düşündükleri alanlar temelinde incelemek ve başarı puanları arasında oluşan farkın istatistiksel olarak anlamlı ölçüde farklılaşmış farklılaşmadığını incelemektir.

Araştırmanın Modeli

Araştırmanın yöntemi niteldir. Bu çalışmada sadece mevcut durum ortaya çıkarılmak istendiğinden, yapılan araştırma betimseldir ve bir özel durum çalışmasıdır.

Çalışma Evreni ve Örneklem

Çalışmaya Antalya’ da bulunan bir ilköğretim okulunun üç 8. Sınıfından toplam 57 öğrenci katılmıştır. Okulun seçiminde, okul yönetimi ve öğretmenlerinin böyle bir çalışmaya izin ve destek vermeleri en önemli nedendir. Sınavın uygulandığı sınıflar A sınıfı dışında heterojen olup, A sınıfı okuldaki en başarılı 8. Sınıf öğrencilerinden oluşmakta olup, sınıf 23 kişiliktir. Aynı zamanda bu sınıfta matematik olimpiyatlarına çalıştırılmış 8 özel öğrenci bulunmaktadır.

Verilerin Toplanması

Öğrencilerine rutin olmayan problemlerden oluşan 11 soruluk klasik bir sınav uygulanmıştır. Sorular hazırlanmadan önce yerli ve yabancı kaynaklardan, ders kitaplarından, internet üzerinden ulaşılan araştırma yazıları ve proje raporlarından rutin olmayan problemler ve bunların çözümünde kullanılan stratejiler araştırılmıştır. Bu tarama sonucunda kaynaklarda en sık rastlanan yedi temel problem çözme stratejisinin çalışılmasına karar verilmiştir. Bunlar, problemi basitleştirme, tahmin ve kontrol, bağıntı arama, şekil çizme, sistematik liste yapma, eşitlik yazma ve geriye doğru çalışma stratejileridir. Stratejilerin her biri için 2 matematik öğretmeniyle birlikte çeşitli sorular hazırlanmış, sonra bunların içinden sorulacak sorulara karar verilmiştir. Sınav sınıf ortamında ve yaklaşık 120 dakikalık bir süre tanınarak uygulanmıştır.

Verilerin Analizi

Öğrencilerin problem çözme stratejilerini belirlemek ve kategorize etmede nitel araştırmalarda kullanılan betimsel analiz yöntemi kullanılmıştır. Çözümlerin incelenmesinin ardından öğrenciler, ileride yönelmek istediği sayısal, eşit ağırlık ve sözel bölümlere göre sınıflandırılmış ve çözümleri incelenip hangi alan öğrencilerinin hangi stratejileri, ne ölçüde kullanabildiği incelenmiştir. Öğrencilerin kullandıkları stratejiler lisede seçecekleri alanlara göre ve ayrıca genel olarak da kullanılan stratejiler temelinde veriler kategorize edilerek bunlara ait elde edilen bulgular frekans ve yüzdeler tablo şeklinde sunulmuştur. Bunun dışında, öğrencilerin soruları doğru yapıp yapmadıklarına 1 ya da 0 puan verilerek elde ettikleri toplam puanları alanlarına göre istatistiksel olarak anlamlı bir farklılık oluşturup oluşturmadığına tek yönlü varyans analizi ve Scheffe Testi ile incelenmiştir.

BULGULAR

Öğrencilerin kullandıkları stratejiler lisede seçecekleri bölümlere göre kategorize edilerek bunlara ait elde edilen bulgular frekans ve yüzdeler şeklinde Tablo 1’ de sunulmuştur.

Tablo 1. Kullanılan Problem Çözme Stratejilerinin Bölümlere Göre Dağılımı

Bölüm	TK	ŞÇ	EY	SLY	GDC	BA	PB	Toplam
Sayısal	27 (%50)	23 (%77)	16 (%84)	6 (%86)	7 (%100)	4 (%80)	4 (%100)	87 (%69)
Eşit Ağırlık	18 (%33)	7 (%23)	3 (%16)	1 (%14)	0	1 (%20)	0	30 (%24)
Sözel	9 (%17)	0	0	0	0	0	0	9 (%7)
Toplam	54 (%95)	30 (%53)	19 (%33)	7 (%12)	7 (%12)	5 (%9)	4 (%7)	126 (%100)

Tablo 1’ e bakıldığında; sayısal öğrencilerin tüm stratejileri kullandıkları, eşit ağırlık öğrencilerinin GDÇ ve PB haricindeki stratejileri kullandıkları ve sözel öğrencilerin ise sadece TK stratejisini kullandıkları görülmektedir. Kullanım oranı (kullanan öğrenci sayısı/toplam öğrenci sayısı) açısından ise en çok TK stratejisi kullanılmış olup (%95), bunu sırasıyla ŞÇ (%53), EY (%33), SLY (%12), GDÇ (%12), BA (%9) ve PB (%7) izlemiştir. Toplam strateji kullanım oranları ise sayısal öğrencilerde %69, eşit ağırlık öğrencilerinde %24 ve sözel öğrencilerde ise %7’ dir. Diğer taraftan, strateji bazında kullanım yoğunluğu (kullanılan strateji sayısı/toplam kullanılan strateji sayısı) ise sırasıyla; TK (%43=54/126), ŞÇ (%24=30/126), EY (%15=19/126), SLY (%6=7/126), GDÇ (%6=7/126), BA (%4=5/126) ve PB (%3=4/126)’ dir. Ayrıca, PB ve GDÇ stratejileri sadece sayısalcular tarafından kullanılmıştır.

Tablo 2. Öğrencilerin Bölümlere Göre Ortalama Başarı Puanları

Bölüm	N	\bar{X}	S
Sayısal	29 (%52)	5.03	2,835
Eşit Ağırlık	19 (%34)	1.53	0,772
Sözel	8 (%14)	1.25	0,463

Tablo 2' ye bakıldığında; sayısal öğrencilerin 11 soru üzerinden ortalama 5.03' ünü (%46), eşit ağırlık öğrencilerinin 1.53 (%14) ve sözel öğrencilerin 1.25 (%11) olduğu tespit edilmiştir. Öğrencilerin 11 sorudan aldıkları ortalama puanlar arasındaki farkın anlamlılığına yönelik yapılan Anova sonuçları Tablo 3' de verilmiştir.

Tablo 3. Öğrencilerin Başarılarına Göre Anova Sonuçları

Varyansın Kaynağı	Kareler Toplamı	sd	Kareler Ortalaması	F	p	Anlamlı Fark
Gruplararası	185.795	2	92.897	21.143	.000	Sy-E, Sy-Sz
Gruplariçi	237.258	54	4.394			
Toplam	423.053	56				

Analiz sonuçlarına göre, öğrencilerin başarı puanları alanlarına göre anlamlı bir şekilde değişmektedir [F(2-54)=21.143, p<.01]. Hangi bölümler arasında farkların olduğunu bulmak için yapılan Scheffe testinin sonuçlarına göre; sayısal-eşit ağırlık ve sayısal-sözel gruplar arasında anlamlı farklılık olduğu tespit edilmiştir.

TARTIŞMA VE SONUÇ

Bulgulara bakıldığında, strateji kullanım yoğunluğunun sırasıyla; TK (%43), ŞÇ (%24), EY (%15), SLY (%6), GDÇ (%6), BA (%4) ve PB (%3) şeklinde olduğu görülmektedir. Bu bulgudan hareketle, verilen problem çözme stratejilerinin kullanımının gerektirdiği zorluk (sayısal zeka) açısından zordan kolaya doğru şu şekilde sıralanabileceği düşünülebilir: Problemi basitleştirme (PB), bağıntı arama (BA), geriye doğru çalışma (GDÇ), sistematik liste yapma (SLY), eşitlik yazma (EY), şekil çizme (ŞÇ), tahmin ve kontrol (TK). Altun (1995) tarafından yapılan çalışmada da şekil çizme stratejisinin, tahmin ve kontrol stratejisine göre daha yoğun kullanıldığı gözlenmiştir. Rina, Auxencia ve Rene (2011) tarafından yapılan çalışmada da en çok şekil çizme stratejisinin kullanıldığı belirtilmiştir. Altun ve Arslan (2006) tarafından yapılan çalışmada strateji kullanım yüzdelerinin kategorik olarak küçükten büyüğe doğru sırayla; bağıntı arama ve geriye doğru çalışma (1. kategori), şekil çizme ve problemi basitleştirme (2. kategori), tahmin –kontrol ve sistematik liste yapma (3. kategori) şeklinde olduğu belirlenmiştir. Diğer taraftan, 1. kategorideki stratejilerin kullanımının yok denilecek kadar az olduğu belirtilmiştir. Bu bulgularla, yapılan bu araştırmadan elde edilen bulgular arasında büyük ölçüde paralellik olduğu söylenebilir. Genel olarak tüm bu araştırmalara bakıldığında; bağıntı arama ve geriye doğru çalışma stratejilerinin en az ve tahmin-kontrol stratejisinin en yaygın kullanıldığı görülmektedir. Bu stratejiler arasında matematiksel zorluk açısından, bağıntı arama stratejisinin daha zor, tahmin ve kontrol stratejisinin ise daha kolay olması bu durumu önemli ölçüde açıklayabilir. Diğer taraftan tahmin ve kontrol stratejisinde çözüm tahmin edilip doğruluğu araştırılır ve bu süreçte aritmetiksel işlemler yapılır ancak bağıntı arama stratejisinde ise cebirsel ifadelerin kullanımı söz konusu olabilir ve dolayısıyla çok daha zordur.

Diğer taraftan; eşit ağırlık öğrencilerin GDÇ ve PB stratejilerini kullanmadıkları ve sözel öğrencilerin ise sadece TK stratejisini kullandıkları görülmektedir. Ayrıca, PB ve GDÇ stratejileri sadece sayısal öğrenciler tarafından kullanılmıştır. Kullanım oranı açısından ise ilk üç strateji şunlardır: TK (%95), ŞÇ (%53) ve EY (%33). Yukarıda verilen strateji sıralamasının, elde edilen bu bulguları önemli ölçüde açıklayabileceği düşünülmektedir.

Toplam strateji kullanım oranları ise sayısal öğrencilerde %69, eşit ağırlık öğrencilerinde %24 ve sözel öğrencilerde ise %7' dir. Başarı oranları ise sayısal öğrencilerde %46, eşit ağırlık öğrencilerde %14 ve sözel öğrencilerde ise %11 düzeyinde gerçekleşmiştir. Yapılan Anova ve Scheffe testi sonucunda, sayısal-eşit ağırlık ve sayısal-sözel gruplar arasında başarı anlamında anlamlı farklılık olduğu tespit edilmiştir. Verilen matematik problemlerinin çözümü sürecinin ve uygun stratejileri kullanmanın daha çok sayısal zeka gerektiriyor olması bu sıralamayı açıklamada etkili bir faktör olarak düşünülebilir.

KAYNAKLAR

- Altun, M. (2006). Matematik öğretiminde gelişmeler. *Uludağ Üniversitesi Eğitim Fakültesi Dergisi*, 20 (2), 223-238.
- Altun, M. & Arslan, Ç. (2006). İlköğretim öğrencilerinin problem çözme stratejilerini öğrenmeleri üzerine bir çalışma. *Uludağ Üniversitesi Eğitim Fakültesi Dergisi* 19(1), 1-21
- Arslan, Ç. & Altun, M. (2007). Learning to solve non-routine mathematical problems. *Elementary Education Online*, 6(1), 50-61.
- Asman, D. & Markowitz, Z. (2001). The use of real word knowledge in solving mathematical problems. *Proceedings of the 25th onference of the International Group for the Psychology of Mathematics Education*, Utrecht, Netherlands.
- Baykul, Y. (2005). *İlköğretimde matematik öğretimi*. Ankara: Pegema Yayıncılık.
- Ben-Hur, M. (2006). *Concept-rich mathematics instruction: Building a strong foundation for reasoning and problem solving*. Alexandria, Virginia: Association for Supervision and Curriculum Development.
- Demirel, Ö. (2005). *Öğretme sanatı*. Ankara: Pegem A Yayıncılık.
- Devlin, K. (2007). *What is conceptual understanding ?* Washington DC: Mathematical Association of America.
- Follmer, R. (2000). Reading, Mathematics and Problem Solving: The Effects of Direct Instruction In The Development of Fourth Grade Students' Strategic Reading And Problem Solving Approaches To Textbased, Nonroutine Mathematics Problems. Ph.D. thesis, Widener University, Chester, Pennsylvania.
- Ford, M. I. (1994). Teachers' beliefs about mathematical problem solving in the elementary school. *School Science and Mathematics*, 94, 314.
- Geiger, V. & Galbraith, P. (1998). Developing a diagnostic framework for evaluation student approaches to applied mathematics problems. *International Journal of Mathematics Education, Science and Technology*, 29 (4), 533-559.
- Higgins, K. M.(1997). The effect of long instruction in mathematical problem solving on middle school students' attitudes, beliefs and abilities. *Journal of Experimental Education*, 66(1),5-28.
- Holton, D. & Anderson, J. (1999). Mathematical problem solving in support of the curriculum. *International Journal of Mathematical Education in Science & Technology*, 30, 351.
- Krulik, S. & Rudnick J. A. (1996). *The new sourcebook for teaching reasoning and problem solving in junior and senior high schools*. Boston, MA: Allyn and Bacon.
- Mayer, R. E. (1982). Memory for algebra story problems. *Journal of Educational Psychology*, 74, 199-216.
- National Council of Teachers of Mathematics (1989). *Curriculum and evaluation standards*. Reston.
- Niederer, K. & Irwin, K. C. (2001). Using problem solving to identify mathematically gifted students. *Proceedings of the 25th Conference of the International Group for the Psychology of Mathematics Education*, Utrecht, Netherlands.
- Orton, A. & Frobisher, L. (1997). *Insights into teaching mathematics*. Redbook Boks Limited, London.
- Polya, G. (1957). *Nasıl çözmeli?* (çev. Feryal Halatçı). İstanbul: Sistem Yayıncılık.
- Pugalee, D. K. (2001). Writing, Mathematics and metacognition: looking for connections through students' work in mathematical problem solving. *School Science and Mathematics*, 101, 236.
- Rina A. M., Auxencia A. L. & Rene R. B. (2011). Problem solving strategies of high school students on non-routine problems: a case study. *Alipato*, 5, 23-46.
- Souviney, R. J. (1989). *Learning to teach mathematics*. Merrill Publishing Company.
- Verschaffel, L. & De Corte, E. (1997). Teaching realistic mathematical modeling in the elementary school: a teaching experiment with fifth graders. *Journal for Research in Mathematics Education*. 28, 577.
- Verschaffel, L., De Corte, E., Lasure, S., Van Vaerenbergh, G., Boagerts, H. & Ratincky, E. (1999). Learning to solve mathematical application problems: a design experiment with fifth graders. *Mathematical Thinking & Learning*, 1(3), 195-229.
- Van de Walle, J.A. (2004). *Elementary and middle school mathematics: teaching developmentally*. New York: Pearson Education, Inc.
- Yaman, S. (2003) *Fen Bilgisi Eğitiminde Probleme Dayalı Öğrenmenin Öğrenme Ürünlerine Etkisi*. Doktora Tezi, Gazi Üniversitesi, Ankara.
- Yazgan, Y. (2007). Observations about fourth and fifth grade students' strategies to solve non-routine problems. *Elementary Education Online*, 6(2), 249-263.

TEACHERS ' VIEW ON EDUCATIONAL RESEARCH

Ceylan ŐEN

Habip BEDİR

Esra SARAÇ

In line with the changing training programs in a variety of different work and research resources are published for informational purposes. Many studies are presented in different application instances to teachers about the renewed program. It is important that teachers follow these studies and practice in their classroom. For this reason, teacher's opinion that related to the new teaching methods and techniques in educational research is included in this study. The study data were collected into two sections. Data were collected that semi-structured interview form was used in the first chapter and Teacher Training Agency developed by Evertone et. al. (2002) and later translated by Beyciođlu et. al. (2010) was used in the second chapter. Research was conducted with 45 science and technology teacher that work in various secondary schools in İstanbul. SPSS 16 for the package program was used for the quantitative data; content analysis method was used for the qualitative data. It was landed up that teachers do not follow education research closely and do not have a lot of information about new teaching methods and techniques and do not take heed of educational research.

Keywords: Educational Research, Teachers' View, Qualitative Research, Quantitative Research.

GEOGEBRA DESTEKLİ ORTAMLARDA ÖĞRENCİLER ARASI ETKİLEŞİMLERİN İNCELENMESİ

İlyas YAVUZ

İbrahim KEPCEOĞLU

Abdulkadir KERPİÇ

ÖZET: Matematik öğretiminde teknolojik araçların yaygın olarak kullanılmaya başlanmasıyla öğrenme ortamları değişmiştir. Dolayısıyla yeni öğrenme ortamlarında öğretmen-öğrenci arası ve öğrencilerin kendi aralarındaki etkileşimler de değişmiş, bunun yanı sıra öğrencilerin bilgisayarlar ile aralarında etkileşimler meydana gelmektedir. Öğrencilerin bilgisayara başında beraber bir geometri sorunun çözümünü yaparken birbirleriyle olan konuşmalarının ve birbirlerine müdahalelerinin incelenmesi öğrenme ortamlarının tasarlanması için önemlidir. Bu nedenle, araştırmanın amacı GeoGebra destekli matematik öğretimi ortamlarında öğrencilerin kendi aralarında meydana gelen etkileşimleri incelemek olarak belirlenmiştir. Araştırmaya Marmara Üniversitesi ilköğretim matematik eğitimi anabilim dalında öğrenim gören 10 öğretmen adayı katılmıştır. Katılımcılar ikiye bölünmüş gruplar halinde 5'er tane geometri sorusunu çözmeye çalışmışlardır. Öğrenciler arası etkileşimleri incelemek için Sinclair'in (2005) müdahale stil ve yöntemleri modeli kullanılmıştır. Araştırma sonucunda öğrenciler arası etkileşimlerin çeşitlilik gösterdiği sonucuna ortaya çıkmıştır.

Anahtar Kelimeler: Öğrenci etkileşimi, bilgisayar destekli matematik öğretimi, GeoGebra müdahale stil ve yöntemleri

ABSTRACT: As technological tools have been widespread used in mathematics teaching, the learning environments have changed. Thus, in these new environments, the interactions between teacher and students and among students have also changed. Moreover, new interactions between students and computers have come into play. To investigate students' conversations, reactions and interventions during a geometric problem solving in computer based environments are important to design learning environments. Therefore in this study, the interactions among students in GeoGebra supported mathematics teaching environments have been investigated. Ten elementary mathematics pre-service teachers have participated to the study. They have worked in groups of two on five different geometric problems. The Sinclair's (2005) intervention styles and strategies model is used to analyze students' interactions. As a result of the study, it is revealed that there is a variety of the interactions among students.

Keywords: student interaction, computer based math teaching, style and methods of GeoGebra intervention

DENEYLE DESTEKLENMİŞ PROBLEME DAYALI ÖĞRENMENİN FEN VE TEKNOLOJİ DERSİNDEKİ BAŞARIYA ETKİSİ

PROBLEM-BASED LEARNING SUPPORTED EXPERIMENT EFFECT ON THE SUCCESS OF SCIENCE AND TECHNOLOGY COURSE

Ebru BAKAÇ

A.İ.B.Ü. Eğitim Programları ve Öğretim Programı Doktora Öğrencisi
ebruli_2239@hotmail.com

Bu araştırmanın amacı deneyle desteklenmiş probleme dayalı öğrenme yönteminin 5. sınıf öğrencilerinin fen ve teknoloji dersindeki akademik başarıları üzerine olan etkisini belirlemektir. Araştırmada ön test – son test kontrol gruplu model kullanılmıştır. Katılımcıları 2011- 2012 eğitim-öğretim yılında İstanbul’da bir ilköğretim okuluna devam eden 81 adet 5. sınıf öğrencisi (41 öğrenci deney grubu ve 40 öğrenci kontrol grubu) oluşturmuştur. Veriler araştırmacı tarafından geliştirilen başarı testi ile toplanmıştır. Deney grubunda 12 ders saati boyunca deneyle desteklenmiş probleme dayalı öğrenme yöntemi uygulanırken kontrol grubunda geleneksel yöntem uygulanmıştır. Araştırma sonunda deney grubu lehine anlamlı bir fark bulunmuştur.

Anahtar Sözcükler: Probleme Dayalı Öğrenme, Fen ve Teknoloji, Akademik Başarı, Deney Yöntemi

The purpose of this research is to examine effect of instruction of problem-base learning with supported experiment on achievement of fifth grade students in science and technology course. Pretest- posttest control group was used in the study. Participants has created 81 fifth grade students (41 student experimental group and 40 student control group) attending a primary school in İstanbul in 2011-2012 academic year. Data were collected by the achievement test developed by the researcher. When problem-based learning supported experimental activities was applied for twelve hours in control group, traditional method was applied in control group. At the end of the study were found a significant difference in favour of control group.

Key words: Problem-based Learning, Science and Technology, Academic Success, Experiment Method

1. GİRİŞ

Günümüzün yeni eğitim anlayışında ise öğrencilerin yaşantılardan kendine özgü anlamlar çıkarması, öğrendiklerini kendine özgü stratejilerle işleyerek onları yeniden yapılandırması beklenmektedir. Öğrenci kendi öğrenme sürecinden sorumlu olan ve en büyük rol sahibi iken öğretmen ise öğrenmeyi kolaylaştırıcı rodedir (Açıkgöz, 2007: 8). Fen öğretiminde kullanılan öğrenen merkezli yaklaşımlardan biri de probleme dayalı öğrenmedir (PDÖ). PDÖ öğrencilerin bir problem çerçevesinde grupça çalışarak araştırma yapmaları amaçlayan bir öğrenme yöntemidir (Arts, Gijsselaers ve Segers, 2002). PDÖ yönteminin kökleri ilerlemeci felsefeye, özellikle Dewey’in öğretmenler öğrencileri yaratıcılığa ve araştırmaya yönlendirmek için içlerinde var olan potansiyeli açığa çıkarmalıdır görüşüne dayanmaktadır (Delilse, 1997: 1). Borrow’s a göre ise PDÖ`nin amacı öğrencilerin problem çözme becerilerini geliştirmektir (Schmidt, 1992). PDÖ yönteminin odak noktası öğrencilerin önceki bilgilerini kullanmalarına ve onları anlamlı ve anlaşılır olan yeni bir form içerisinde yapılandırmalarına yardımcı olmaktır (Savin-Baden ve Major, 2004). PDÖ’de öğrenciler problemle bağlantılı bilgileri araştırırlar ve elde ettikleri bilgileri değerlendirirler. Araştırarak öğrenme veri toplama, düşünme becerilerini kullanma ya da fikir üretme, değerlendirmede farklı seçenekleri kullanma ve çözümü uygulama seçeneklerini içerir (Demirel, 2010: 82). PDÖ yönteminde sınıflara yazılı senaryolar, anekdotlar, video, teyp gibi araçların yardımıyla gerçek bir problem durumu getirilir. Problemler gerçek yaşamdan seçilir. Öğrenciler sekiz kişiden daha az küçük gruplara ayrılır. Gruptaki öğrenciler haftada en az iki defa toplanırlar. Öğrenciler bu problem durumu ile ilgili önceki yaşantılarını ve bilgilerini birbirleri ile paylaşırlar (Kaptan ve Korkmaz, 2001). En az altı ya da sekiz oturum tekrarlanarak öğrenciler öğrendikleri yeni bilgilerle problemi çözmeye çalışırlar (Schwartz, 2001: 2). PDÖ’nin, fen eğitimi için büyük önem taşıyan bazı avantajları vardır. Bunlar; öğrencilere bilimsel işlem becerilerini kazandırması, grupla çalışma becerisi kazandırması, öğrencilerin problem çözme becerisini geliştirmesi, fen okuryazarlığını artırması, öğrencilerin kendi kendine öğrenme becerilerini geliştirmesi, öğrencilere analiz, sentez ve değerlendirme gibi üst düzey bilişsel beceriler kazandırması (Tatar, 2007).

PDO'nin fen ve teknoloji dersinde başarıyı arttırdığını gösteren birçok çalışma bulunmaktadır (Deveci, 2002; Erdem, 2006; Kerfoot, Masser ve Hafler, 2005; Yıldız, 2010). Ancak PDÖ yönteminin daha verimli hale getirilebilmesi için PDÖ uygulamalarının çeşitli yöntemlerle desteklenmesinin yararlı olabileceği düşünülmektedir. Bu yöntemlerden biri deneydir. Deney yöntemi, belli bir doğa olayını, etmenleri denetim altında tutarak sınıf veya deney odasında (lâboratuvar) öğrencilere göstermek için yapılan plânlı bir deneme veya sınamaya işi olarak tanımlanabilir (Büyükkaragöz ve Çivi,1999: 94). Bu yöntemin başarılı olabilmesi için bir plâna göre yapılması gerekir. Bir deney plâni ana hatlarıyla şu başlıklardan oluşur. 1) deneyin yapılacağı ders, sınıf ve saatler, 2) deneyin konusu, 3) deneyin amaçları, 4) Kullanılacak araç ve gereçler, 5) amaçların gerçekleşmesi için öğrencilerin yapacağı etkinlikler, 6) deney sonucunun değerlendirilmesi (Hesapçioğlu,1994: 222). Araştırmacının yaptığı literatür taraması sonucu PDÖ'nin deney yöntemi ile desteklenmesinin 5. sınıf fen ve teknoloji dersindeki akademik başarıya etkisini sınavan bir çalışmaya rastlanmamıştır. Bu nedenle çalışmanın literatüre bir katkı getireceği, bu alanla ilgili araştırma yapacaklara yol göstereceği düşünülmektedir. Bu nedenden dolayı araştırma deneyle desteklenmiş PDÖ'nin öğrencilerin akademik başarıları üzerine olan etkisini belirlemeyi amaçlamaktadır. Bu amaç ekseninde aşağıdaki soruya yanıt aranacaktır:

Deneyle desteklenmiş PDÖ yöntemi kullanılarak öğretim yapılan deney grubu öğrencileri ile yapılandırılmıy yaklaşım kullanılarak öğretim yapılan kontrol grubu öğrencilerinin son-test puanları arasında deney grubu lehine anlamlı bir fark var mıdır ?

2.YÖNTEM

Araştırmada öntest – sontest kontrol gruplu model kullanılmıştır. Bu yöntem; kişilerin deney ve kontrol gruplarına gönderilmesinde rastgele dağılımın kullanılmadığı bir deneysel araştırma yöntemidir. Öğrencilerin deneysel işlemde önce ve sonra bağımlı değişkenle ilgili olarak ölçüldüğü ilişkili bir desendir. Çünkü aynı kişiler bağımlı değişken üzerinde iki kez ölçülürler (Büyüköztürk, 2010).

Tablo 1. Araştırma Deseninin Simgesel Görünümü

Deney Grubu	R	T1	X	T2
Kontrol Grubu	R	T1		T2

Katılımcılar

Araştırmanın katılımcılarını 2011- 2012 eğitim-öğretim yılının birinci döneminde İstanbul'da bir ilköğretim okulunda öğrenimlerine devam eden 81 adet 5. sınıf öğrencisi oluşturmuştur. Deney ve kontrol gruplarının denkleştirilmesinde öğrencilerin ön-testten aldıkları puanlar kullanılmıştır.

Tablo 2. Deney ve Kontrol Grubunun Ön Test Puanlarına Göre t- testi Sonuçları

ŞUBE	N	X	SS	s	t	p
DENEY	41	11,17	3,33	79	0,289	0,774
KONTROL	40	10,95	3,55			

Tablo 1'e göre deney ve kontrol grubunun ön-test puanlarında anlamlı bir fark yoktur, $t(79)=0,289$, $p>.05$. Bu verilere göre öğrencilerin uygulama öncesinde fen ve teknoloji dersine yönelik başarı testi puan ortalamaları; deney grubunda ($X =11,17$) ve kontrol grubunda ($X =10,95$) olarak benzerlik göstermektedir. Bu bulgudan hareketle deney ve kontrol gruplarının başarı yönünden denk oldukları söylenebilir.

Verilerin Toplanması

Başarı Testi

Araştırmanın verileri araştırmacı tarafından geliştirilen Maddenin Değişimi ve Tanınması Başarı Testi ile toplanmıştır. Testte yer alacak soruların belirlenmesinde, geniş bir literatür taraması yapılarak değişik türden test kitapları incelenmiş ve çok sayıda soru toplanmıştır. Toplanan sorulardan hangilerinin kullanılacağına karar verme aşamasında, öğrenci seviyeleri ve programda konu ile ilgili yer alan kazanımlar esas alınmıştır. Hazırlanan başarı testi belirteci tablosunda gösterilerek testteki soruların kapsam geçerliği sağlanmaya çalışılmıştır. Ayrıca testin kapsam geçerliliği için 2 fen ve teknoloji ve 1 sınıf öğretmenin görüşlerine başvurulmuştur ve öneriler doğrultusunda gerekli değişiklikler yapılmıştır. Geliştirilen Maddenin Değişimi ve Tanınması Başarı Testi madde analizi yapabilmek için pilot uygulama olarak bu konuları gören 125 tane 6. sınıf öğrencisine uygulanmıştır. Uygulama sırasında öğrencilerin tüm soruları cevaplamak için ne kadar zamana ihtiyaç duydukları ve soruları anlamakta zorluk çekip çekmedikleri belirlenmiştir. Uygulama sonunda testin geçerlik ve güvenilirlik araştırması yapılmıştır. Madde analizi sonucunda maddenin ayırt ediciliği değerlendirilirken şunlara dikkat edilmiştir: Ayırt edicilik indisi 0,40 veya daha yüksek bir değerde olan maddeler çok iyi, 0,30–0,40 arasında olanlar iyi sayıldığından teste alınmış; 0,20–0,29 arasında olan birkaç madde de zorunlu hallerde aynen kullanılabilir olduğundan teste alınmış; 0,20’den daha küçük bir değerde olan maddeler testte kullanılmamıştır Ayırt ediciliği sıfır veya negatif olan maddeler de testte kullanılmamıştır (Yılmaz, 2004: 226). Güvenirlik tahmininde 0,00 ile 1,00 arasında değerler elde edilir. Güvenirlik indeksinin 1,00’a yakın olması testin güvenilirliğinin yüksek, 0,00’a yakın olması da testin güvenilirliğinin düşük olduğu anlamına gelir (Yılmaz, 2004: 215). Başarı testlerinde cevapların doğruluğu ve yanlışlığı mantığına uygun düştüğü için güvenilirliği hesaplamada genellikle Kuder-Richardson 20 formülü kullanılmaktadır. Nihai testin 20 sorudan oluşmasına karar verilmiş ve testin aritmetik ortalaması X: 8.65, standart sapması Ss: 4.68, ortalama güçlük değeri P: 0.43 ve güvenirlilik katsayısı KR20= 0.74 bulunmuştur.

İşlem Basamakları

- 1- Deney ve kontrol gruplarının belirlenmesinde öğrencilerin ön test puanları kullanılmıştır.
- 2- Öğrencilere önce araştırma hakkında bilgi verilmiştir. Araştırma sırasında uygulanan başarı testinin araştırmanın amaçlarına ulaşması açısından önemli olduğu vurgulanarak öğrencilerden bu testi cevaplarken samimi olmaları istenmiştir.
- 3- Deney ve kontrol gruplarına araştırma başlamadan önce ön test olarak başarı testi uygulanmıştır.
- 4- Çalışma haftada dörder saat olmak üzere toplam 3 haftalık bir süreci kapsamıştır.
- 5- Kontrol gruplarında yapılandırmacı yaklaşıma dayalı öğretim yöntemi kullanılmıştır.
- 6- Deney ve kontrol gruplarına araştırmanın bitiminde son test olarak başarı testi uygulanmıştır.

Verilerin Analizi

Deneyle desteklenmiş PDÖ yöntemi uygulanan deney grubu ile yapılandırmacı yaklaşımın kullanıldığı kontrol grubu öğrencileri arasında başarı düzeyleri bakımından fark olup olmadığını test etmek için SPSS 16.0 (Statistical Package for The Social Science) paket programı kullanılmıştır. Anlamlılık düzeyi. 05 olarak belirlenmiştir. Veriler ilişkili örneklem t-testi ile analiz edilmiştir.

3. BULGULAR

Tablo 3. Deney ve Kontrol Grubu Öğrencilerinin t- testi Sonuçları

ŞUBE	N	X	SS	s	t	p
DENEY	41	15,48	3,09	79	4,055	0,000
KONTROL	40	12,80	2,85			

Tablo 4’e göre deney ve kontrol grubunun son-test puanları arasında anlamlı bir fark oluşmuştur, $t(79)=4,055$, $p<.05$. Bu verilere göre öğrencilerin uygulama sonrasında fen ve teknoloji dersine yönelik başarı testi puan ortalamaları; deney grubunda ($X=15,48$) ve kontrol grubunda ($X=12,80$) olarak farklılık göstermektedir. Bu bulgudan hareketle deneyle desteklenmiş PDÖ`nin akademik başarıyı arttırmada yapılandırmacı yaklaşımın uygulandığı geleneksel öğretime göre daha etkili olduğu söylenebilir.

4.TARTIŞMA

Araştırma sonunda deney yöntemi ile desteklenmiş PDÖ'nin akademik başarıyı arttırmada geleneksel öğretime göre (yapılandırmacı yaklaşım) daha etkili olduğu bulunmuştur. Araştırmanın bulgusuna paralel olarak Yıldız (2010) ve Çınar (2007) da PDÖ'nin öğrencilerin akademik başarılarına olumlu etkisi olduğunu belirtmektedirler. Aydoğdu (2012) da Fen Bilgisi öğretmenliği öğrencilerinin elektroliz ve pil konularını öğrenmelerine PDÖ'nin etkisini incelemiş, başarı yönünden deney grubu lehine anlamlı bir fark bulmuştur. Taşoğlu ve Bakaç (2013) tarafından yapılan çalışmada lisans düzeyinde manyetizma konularının öğretiminde, probleme dayalı öğrenme yaklaşımı ve geleneksel öğretim yöntemleri karşılaştırılmış. Araştırma sonunda deney grubunun anlama yüzdelilerinin kontrol grubuna oranla genellikle daha fazla olduğu sonucuna ulaşılmıştır.

Araştırma sonuçlarına paralel olarak eğitimcilere ve araştırmacılara aşağıdaki önerilerde bulunulmuştur: PDÖ'nin daha iyi uygulanabilmesi için senaryo yazımı ve PDÖ basamakları hakkında öğrencilere gerekli eğitimin verilmesi, PDÖ konusunda eğitim fakültelerinde okutulan öğretim ilke ve yöntemleri dersinde uygulamalar yaptırılması, araştırmacıların farklı sınıf seviyeleri ve derslerde PDÖ'nin farklı değişkenler üzerine etkisini sınavan çalışmalar yapması önerilmektedir. Bu çalışmanın öğretmenlere yeni yöntem ve teknikler konusunda bilgi sunacağı ve araştırmacılarda yeni bakış açıları oluşturacağı düşünülmektedir.

KAYNAKÇA

- Açıkgöz, K.Ü. (2007). *Başarmak elimizde*. İzmir: Bil Yayınları.
- Arts, J. A.R., Gijsselaers, V. H., ve Segers, M. S. R. (2002). Cognitive effects of an authentic computer-supported, problem-based learning environment. *Instructional Science*, 30, 465–495.
- Aydoğdu, C. (2012). Elektroliz ve pil konularının öğretiminde probleme dayalı öğrenme yaklaşımının etkisi. *Hacettepe Üniversitesi Eğitim Fakültesi Dergisi*, 42, 48-59.
- Büyükkaragöz, S. S. ve Çivi, C. (1999) *Genel öğretim metotları*. İstanbul: Beta Basın Yayın Dağıtım.
- Büyüköztürk, Ş. (2010): *Sosyal bilimler için veri analizi el kitabı*. (11. Baskı).Ankara.: Pegem A Yayıncılık.
- Çınar, D. (2007).*İlköğretim fen eğitiminde probleme dayalı öğrenme yaklaşımının üst düzey düşünme becerilerine ve akademik risk alma düzeyine etkisi*. Yayınlanmamış Yüksek Lisans Tezi. Konya: Selçuk
- Delilse, R. (1997). How to use problem-based learning in the classroom. Virginia: Association for Supervision and Curriculum Development
- Demirel, Ö. (2010). Eğitimde yeni yönelimler. (4. Baskı).Ankara: Pegem Akademi.
- Deveci, H. (2002). *Sosyal bilgiler dersinde probleme dayalı öğrenmenin öğrencilerin derse ilişkin tutumlarına, akademik başarılarına ve hatırlama düzeylerine etki*. Yayınlanmamış Doktora Tezi. Eskişehir: Anadolu Üniversitesi Eğitim Bilimleri Enstitüsü.
- Dochy, F., Segers, M., Bossche, P. ve Gijbels, D. (2003). Effects of problem-based learning: a meta-analysis. *Learning and Instruction*.13(5), 533-568.
- Erdem, E.(2006).*PDÖ' nin Öğrenme Ürünlerine, Problem Çözme Becerisine ve Öz-yeterlik Algı Düzeyine Etkisi*. Yayınlanmamış Doktora Tezi, H.Ü. Sosyal Bilimler Enstitüsü, Ankara.
- Hesapçıoğlu, M. (1998). *Öğretim ilke ve yöntemleri*. İstanbul: Beta Basım Yayın
- Kaptan, F. ve Korkmaz, H. (2001). Fen eğitiminde probleme dayalı öğrenme yaklaşımı. *Hacettepe Üniversitesi Eğitim Fakültesi Dergisi*, 20, 185 -192.
- Kerfoot, B.; Masser, B. ve Hafner, J. (2005).Influence of new educational technology on problem-based learning at Harvard Medical School. *Medical Education*,39, 380–387.
- Schmidt, H. C. (1992). Problem based learning: Rationale and description, *Medical Education*,17,11–16.
- Schwards, P. (2001). *Problem based learning*. Newyork: Routledge.
- Savin-Baden, M. ve Major, G. H. (2004). *The society for research into higher education foundations of problem-based learning*. Berkshire: McGrawHill Education.
- Taşoğlu, A. K. ve Bakaç, M. (2013). *Manyetizma konularının öğretiminde probleme dayalı öğrenme yaklaşımının kavramsal anlamaya etkisi*. 1. Ulusal Fizik Eğitimi Kongresi Bildiri Özetleri Kitabı. (12-14 Eylül), Ankara.
- Tatar, E. (2007). *Probleme dayalı öğrenme yaklaşımının termodinamiğin birinci kanununu anlamaya etkisi*. Yayınlanmamış Doktora Tezi. Erzurum: Atatürk Üniversitesi.
- Yıldız, N. (2010).*Fen eğitiminde probleme dayalı öğrenme senaryolarının çözümünde deney uygulamalarının öğrencilerin başarısına, tutumuna ve bilimsel süreç becerilerine etkisi*. Yayınlanmamış Yüksek Lisans Tezi. İstanbul: Marmara Üniversitesi.
- Yılmaz, H. (2004). *Eğitimde ölçme ve değerlendirme*. (7.Baskı) Konya: Çizgi Kitabevi Yayınları.

THE STUDY OF THE EFFECTIVENESS OF APPLYING THE CONSTRUCTIONAL APPROACH IN MATERIALIZING THE GOALS OF THE CURRICULUM OF THE INTELLIGENT SCHOOLS

Seyyed Abdollah HOJJATI
P.H.D candidate of Islamic Azad University and the faculty of Bonab Azad Islamic university
(abdollahbonabi@gmail.com)

Seyyedeh Firuzeh HOJJATI
The teacher of Bonab institutes
(frhojjati@gmail.com)

Mortaza BARIN
The teacher of Tarbiat Moallem University
(mbarin623@yahoo.com)

ABSTRACT: One the basic and the fundamental differences between the traditional and the intelligent schools, which has proposed in our country and has been conducted in some schools since 2005, is the method of learning and teaching in these schools which should be learnt by the teachers of these schools. But the constructional teaching approach, with regard to the features it possesses, can contribute to materialize the goals of the intelligent schools in case it is used by the teachers. Because the tasks of the teachers and the students in the schools match greatly with the tasks of the teachers and the students in the constructional approach if it is applied. Therefore in this article the author, by studying the features of the constructional approach of teaching and the principle bases of the intelligent schools concludes that if the teachers of the intelligent schools are well- familiar to the constructional teaching approach, they can be to large extent useful in materializing the goals of the intelligent schools and playing the teaching role.

Key words: constructional Approach, Curriculum of the intelligent Schools

THE DEFINITIONS OF CONSTRUCTIONAL APPROACH

Constructional approach has been defined in various ways but all of them focus on the active role of the learners in the comprehension and construction of knowledge. According to Santrock (2004) constructional approach is a learning approach which focuses on the activeness of learners in the construction of knowledge and understanding (p. 561). Also, Schunk (2000) argues that, “constructional approach is a psychological and philosophical viewpoint according to which people construct and form most of their own learning (p. 229).

To be brief, constructional approach is based on the idea that learners gain knowledge from their own experiences (Ormrod, 1995).

Nowadays, rather new theories have been presented in psychology and education which are called Constructivism and have their root in the past scientific and philosophical ideas. Constructivism has its origins in the works done by Piaget, Vygostky, Gestalt psychologists, Bartlett, Bruner, and Dewey’s philosophy of education. All the above-mentioned works only constitute a part of the literature review (Woolfolk, 2004).

Constructivism can be defined as, “knowledge as a result of the productive activities of individuals”. Knowledge is not outside the minds of those who want to acquire that and is not the result of the experience of others, but is the consequence a person’s own experience. Teaching according to constructivism helps learners to internalize newly acquired information and give new form to or modify them (Salimi, 2009).

Based on constructivism, there is not any independent reality but all types of reality depend upon the minds of people and mind is a base and tool for the interpretation of events, objects, and prospects in the world and such interpretations establish knowledge. Today, the main focus in education is on innovations, creativity, and the construction of knowledge and to base teaching methods on the interaction of learners with the environment and discovery of facts. So, the constructional approach has a special consistency with this issue because in this approach focuses on personal achievements and the invention of methods and concepts. Also, it must be noted

that in this approach, teachers and other equipment are considered as the “facilitators” of knowledge construction by learners.

Teachers who are interested in planning and teaching their subject matter according to constructivism accept to and must play different roles. The main task for teachers in this method is to facilitate the process of knowledge construction and to guide learners in this process.

Before the levels in the execution of constructivism be explained, it must be mentioned that teachers need to take into account the important topics in the following table and put those topics as guidelines for themselves in the execution of constructivism.

The Major Concept In Constructivism

1. The concept of construct

Construct means a framework consisting of a set of concepts (for example, the concepts related to an event or accident, a system, or knowledge). In order to assign meaning to the natural phenomena, learners must create mental constructs in an informed way and based on such constructs which include beliefs, opinions, and knowledge try to interpret reality.

2. The concept of knowledge construction

This concept means the mental production of information.

Learners must take the responsibility of their own learning and the method of learning by themselves and must choose or develop their own learning strategies and set their own educational goals.

3. The concept of reality

In constructivism, reality is not outside a person’s mind but is a meaning which has been constructed by the person based on the world he lives.

Steps In The Execution Of Constructivism

1. Searching an exploration

It means looking for ways to construct knowledge by the learners. In this step, learners attempt to construct knowledge by getting help from all their senses. The construction of knowledge occurs throughout the process of search and exploration. In this step, the teacher tries to explain the topic and ask the students to express their own information, skills, and ideas. This step is roughly the first step in brainstorming and the inductive approach. (the genesis of concepts)

2. Understanding and explanation

In this step, teachers and students discuss about the information, skills, and ideas presented in the previous step. In other words, reaching to an agreement on the issues presented is the most important task in this step. Here, teachers ask Why and How questions related to the arguments put forward by learners.

Teachers should guide their students to share their ideas and findings with other members of the group.

3. Generalization and spread

In this step, teachers help their students to generalize and expand their findings. In other words, helping the learners to improve and develop personal information and skills and expanding them to other. In this step, the topic is expanded when students study reference books and get information from others. Usually, making use of extension homework can help to expand the topics.

4. Checking and evaluation

In this step, all the activities, skills, and findings are checked and evaluated in order to determine the amount of changes in thoughts, mastery of skills, learned materials, and the construction of knowledge. In order to evaluate the learned materials, thought provoking questions and such tools as interviews with informed people and

referring to useful resources can be used. Also, the results gained from this step should be made use of in teaching and learning systems (Shabani, 2010).

The Major Characteristics In A Constructivist Instructional Design

1. The goals are developed in a more comprehensive and basic way.
2. A suitable learning environment is being provided.
3. Teachers and students help each other to select those activities, materials, projects, and operations which help learners to understand the subject matter.

Also, the process of learning and the thoughts behind that is emphasized over the product of learning (Seif, 2010).

SMART SCHOOLS

A smart school is a physical school in which the control and administration is done based on computer and networks and the materials are mainly electronic. Also, testing and monitoring systems in such schools are smart. In these types of schools, a smart student develops and modifies his/her executive abilities and resources by being involved with various topics in a continuous way and this issue lets school officials to make their students ready to acquire new information by considering the changes happened and the increase in the level of information that their students are familiar with.

The Objectives Of Smart Schools

1. Comprehensive development of students (mental, physical, emotional, and intellectual)
2. Upgrading personal capabilities
3. Training humans who are contemplative and familiar with technology
4. Increasing public participation

In smart schools, students are both teachers and learners. In such schools, the curriculum is not limiting and students are allowed to go beyond their curriculum. There, teaching methods are based on student-centeredness. Focus on thinking abilities and the provision of a teaching-learning environment are among the strategies and policies of smart schools. Seven key principles in smart schools include: 1. creative knowledge, 2. learning aptitude, 3. attention to the understanding of materials, 4. learning with the goal of mastery of the content and transferring it, 5. the evaluation of learned materials in a focused way, 6. overcoming difficulties, 7. School as an educational organization. In smart schools, students can use CDs and computers are used instead of blackboards. Here, students can get a lot of information on any subject by the use of the Internet. In these schools, teaching is not merely done by teachers but students are also involved in the process of teaching. Teachers help students to understand the topics better and save more time by making use of electronic materials and students have the chance to demonstrate their abilities and produce educational materials.

Success is accessible in these schools and the rate of success depends on students' effort and perseverance and a right direction. In this method, the spirit of research and explorations replaces an aimless spirit among learners. In constructivism, the main prerequisite for any change is the change in thought and tools and equipment are just used in order to realize thoughts.

Instead of providing the answers to students' questions, teachers can ask their students to look for the answers of their questions and tell them to the other students.

The foundations for the development of smart schools are making use of modern information and communication technologies and their difference with virtual schools is that here the students must be present physically at the schools but in virtual schools teachers and students can be hundreds of kilometers apart from each other. There is not any necessity for the teachers in smart schools to be masters of IT but they need to be informed of the system of such schools and make good use of the equipment there. A teacher should know where the resources are so that when students ask questions, he/she can guide them to the required resources.

Parents communicate with smart schools through computers and have the possibility to connect with the principal and get informed of the educational status of their children.

Libraries in smart schools are electronic and students can use them in an online way. Discussion and question and answer forums are provided in a synchronous and asynchronous way.

The Pillars Of Smart Schools

Teaching – Learning environment

This domain covers four areas:

- a. Curriculum
- b. Teaching methodology
- c. Evaluation
- d. Content

Administration

Supports the resources and processes required in a teaching – learning environment.

People's responsibilities and the required skills: In smart schools, the roles of principals, students, and parents are changed in order to play a more effective role by making use of their abilities and knowledge.

Technology

Teaching – learning environment, administration, and external communications necessitate solutions which are based on the use of technology.

The characteristics of the pillars of smart schools

a. Curriculum

The principles governing the curriculum in smart schools include: Designing to help students develop in a comprehensive way, the integration of students in order to develop in a comprehensive way, the integration of knowledge, skills, and values through curriculum (by assigning the activities related to content into projects), discipline and continuity in education, establishing positive attitudes towards the use of technology, getting all the students to access suitable education.

The attitudes towards curriculum

Meaningfulness: All students understand the concepts in education in order to understand the goals of their education.

Social Responsibility: Students get informed of their responsibilities in the society and feel responsible towards their people.

The feedback of curriculum: Curriculum should induce learners with critical thinking and skills, and positive creativity.

Comprehensiveness: Curriculum should focus on all aspects of human beings and help learners to understand the relations between different topics.

Non-restrictiveness: Curriculum is not restrictive. First, the current programs are being revised in a “continuous” way. Secondly, the students are allowed to go beyond the curriculum.

Being targeted: Curriculum makes use of technology as an instrument to transfer knowledge and teaches the students how to make use of it in order to get help from it in times of need.

b. Teaching Methodology

The teaching methodology used in smart schools is student-centered and the following principles govern the methodology used there:

The provision of a combination of teaching methods to make sure of the comprehensive development of students' aptitudes and abilities in order to:

- a. Encourage learning and develop creativity
- b. Making the activities student-centered and develop individual skills
- c. The provision of various educational methods to develop learning
- d. The direction of classes by making use of various teaching – learning methods

In smart schools the students have a more important role in a way that:

Students form the educational goals by getting help from teachers.

Students determine educational tasks by getting help from teachers.

In the selection of materials, students consider the materials themselves and ask for teachers' attitudes on them.

c. Evaluation

In smart schools, evaluation is smart and sometimes is not smart depending the lesson type.

The characteristics of evaluation:

Comprehensive

Various forms

Multiple-choice methods

On time

Student centered

Continuity

Evaluation is performed in a comprehensive way in smart schools and in addition to the summative evaluation includes readiness and development and provides various forms of information on students' abilities learning methods.

Initial evaluation: The evaluation of the level of knowledge and abilities

Formative evaluation: The evaluation of a student's ongoing development in order to determine strong and weak points

Summative evaluation: Considering the current educational system, this type of evaluation is performed in a pencil – and- paper method to evaluate students' learning.

Evaluation is designed in different forms such as: classroom evaluation, school evaluation, and focused (centralized) evaluation.

Classroom evaluation: This type of evaluation is performed during and after the lessons.

School evaluation: It is performed after each section of the lessons has been finished.

Focused evaluation: This type is performed in the form of a project whenever learners demonstrate their readiness.

d. Content

Content is provided in two forms in smart schools:

Standardized content (through the Ministry of Education)

Teacher content

Generally speaking, content is formed based on four major indicators:

1. Technical quality
2. Attraction
3. Educational quality
4. Accordance with the curriculum

THE APPLICATIONS OF CONSTRUCTIONAL APPROACH IN ELECTRONIC LEARNING ENVIRONMENTS:

The constructional approach provides ideas and principles that are important for learning environments by getting help from technologies. Those ideas and principles are as follows:

1. Learning takes place in real and meaningful conditions. In order to realize this, students should participate actively in the process of decision-making.
2. Learning is turned into an individual and social activity. The influences of technology on learning have a deep impact on the social aspects of learning. This is because we can observe the individual activities of students when they are working with computers. On the other hand, technology provides students with various social learning situations and allows to learn better through computers, social networks, electronic mail, and telecommunications.

The growing understanding of the important roles that learning environments can play with the help of technology might lead to the creation of different learning environments such as environments for social and creative learning which are focused in the Constructional approach (Lotfi & Abdollahi, 2010).

DISCUSSION AND CONCLUSION

Based on what mentioned before it can be concluded that the Constructional approach have some features that can be effective in the realization of objectives in smart schools. It can be argues that there is a high degree of similarity between the learning situations that teachers in the constructional approach create for their students with the situations that teachers in smart schools desire to establish. So, it can be said that as teachers who design educational plans based on constructivism are considered as the facilitators of the process of knowledge construction and help and guide students in the construction of knowledge, teachers in smart schools play the role of guides in the process of education and create situations for the students to learn how to learn.

If teachers make use of the Constructional approach in order to teach their students how to process information, think about various data and information, use the materials learned in daily life, know different sources of information (global and local), and connect in a suitable and effective way with others through media, in fact they help them to be involved in the process of learning. In other words, they help their students to manage their own learning and give depth to it. It is clear that the above-mentioned situations are the objectives that are being followed in smart schools. So, if teachers in smart schools have a command of the Constructional approach and provide students with interactive learning, they would be able to advance the objectives of smart there schools through the establishment of a real and meaningful learning environment.

REFERENCES

- C., T. (2009). Towards constructivist classrooms. *Educational Technology*, 1, 44.
- Lotfi, A., & Abdollahi Hosseini, A. (2010). The relationship between constructivism and electronic technologies. *Educational Technology*, 4, 12-13.
- Ormrod.J.E(1995).*educational psychology principles and applications*.Englewood cliffs,Nj:Merril.
- Santrock,j.w,(2004), *educational psychology*.new York:Mc grow-Hill. <http://www.e->

bookspdf.org/download/educational-psychology-john-santrock.html

Schunk, D.H(2000). learning theories: An educational prespective. Uppersaddle River, Nj: Prentice-Hall.

Seif, A. A. (2010). Modern Educational Psychology. Tehran: Doran Publications .

Shabani,A.(2010).Constructivism.Retrieved from <http://moalem1370.blogfa.com/post-50.aspx>

Shahidi, Z. (2010). What is constructivism? Retrieved from www.sair.ir: www.sair.ir

Wolfolk,A.E.(2004).educational psychology.Boston:Allynand bacon.

A SURVEY OF INFLUENCE OF ENVIRONMENT AS A MOTIVATOR ON SECONDARY SCHOOL STUDENTS' PERFORMANCE IN MATHEMATICS IN NIGERIA

Suleiman BASHIR PhD
absuleimank@gmail.com
+2348060431859
Department of Mathematics
Federal college of Education (Tech) Gusau, Nigeria

ABSTRACT: The study investigated the Influence of Environment on the Performance of Secondary School Students in Mathematics in some selected States of the Northwest of Nigeria. The study is a survey research type and the sample size is 1000 Secondary School Students from Three States of Kebbi , Sokoto and Zamfara . The self-developed questionnaire was used for data collection and the percentage and mean were used to answer the research questions while Chi-square was used to answer the hypothesis. The finding revealed that the Environment of the School and the Student's house has influence on the student's Academic Performance in Mathematics. The researcher recommended that School should be cited far away from noisy areas such as Market and Industrial estate. This will control the pollution of the Environment and distraction from Academic work. Research study like this can also be conducted using other Geo-political areas of the Country or any other part of the World.

INTRODUCTION

The term environment can be regarded as the surroundings in which an organism operates which include air, water, land, natural resource, flora, human and their interrelation (Romer, 1993). Owitti (2001) stated that environment of an organism includes both the physical properties such as local biotic factors like climate and geology, as well as other organisms that share its habitat. The environment based on the above definitions can be seen as a complex of physical, chemical and biotic factors such as climate, soil and living things that act upon an organism or ecological community and ultimately determine its form and survive. In other words, the environment is the sum of all external conditions affecting the life, development and survival of an organism. Among the factors responsible for the state of learning in general and mathematics in particular is environment. Condition of learning environment matters a lot in the students' learning ability. The environment of a student is both school and home environment. This research study tried to find out the extent to which both school and home environment influences student's performance in mathematics.

METHODS

The research is a survey study in which 1000 secondary school students were both purposively and randomly sampled from the population of senior secondary school students from Kebbi, Sokoto and Zamfara states of Nigeria. The students sample size per state is in ratio 7:7:6 for Kebbi, Sokoto and Zamfara states respectively.

Researcher's self-developed questionnaire was used for the study .Items in the questionnaire were based on school and home environment condition of the students. The questionnaire was subjected to validation and has reliability coefficient of 0.71 using test-retest procedure. The questionnaire was administered personally by the researcher in the three states and did the analysis using the mean to answer the research questions and t-test for testing the hypothesis.

Research Questions

The following research questions were answered in this study.

1. Does the environment has any influence on the student's performance in Mathematics?
2. Does the school environment has any influence on the student's performance in Mathematics?
3. Does the students's home environment has any influence on his/her mathematics performance?

Research Hypothesis

The following hypothesis was tested in this study.

There is no significant difference in the students' view on the influence of school and home environment on their performance in Mathematics.

RESULTS AND FINDINGS

The researcher used Likert Scale of four points for the transformation of the opinion of students of strongly agreed, agreed, disagreed and strongly disagreed into quantitative data. The acceptance of influence level used for the study is 2.50. The analysis techniques used to answer the research questions are the frequency counts and means.

Research Question 1: Does the environment has any influence on the students' performance in Mathematics?

Table 1. Students' View on Influence of Environment on Performance in Mathematics

Item	Students 'View				Total	Mean	Dec
	Strongly agreed	Agreed	Disagreed	Strongly Disagreed			
Schools located around Factories are exposed to noise and air pollutions which contaminates the air and causes health problems to the students. this induces drop in students performance in mathematics	700	200	50	50	1000	3.55	Acc
Stimulating environment promotes positive attitude in students and enhances performance in mathematics	800	100	100	0	1000	3.70	Acc
Condition of learning affects teacher's behavior and attitude towards teaching and consequently affect students' performance	850	150	0	0	1000	3.85	Acc
School building condition can affect student's self –							

worth and esteem and may influence his performance in Mathematics	750	150	75	25	1000	3.63	Acc
Poor school environment leads to poor attendance, low concentrate and unhealthy motivation in which leads to student's poor performance in mathematics	700	200	50	50	1000	3.55	Acc
Teaching mathematics under hot afternoon makes students lose concentration and may affect their performance in mathematics	900	75	25	0	1000	3.88	Acc
Unhealthy school environment exposes students to disease and this affects their performance in mathematics	950	25	25	0	1000	3.93	Acc
Poor lighting and ventilation in the classrooms affects student's behavior such as paying no attention to their teachers and thereby affect their performance in mathematics	600	150	150	100	1000	3.25	Acc
School environment affects student's Performance in mathematics	750	150	75	25	1000	3.63	Acc

My house is always dirty	25	100	100	775	1000	1.38	Rej	
My house has a reading room/ library		50	50	100	800	1000	1.35	Rej
Conducive home environment enhances child academic success		600	150	100	150	1000	3.20	Acc
My house is located in an isolated area		25	50	250	675	1000	1.43	Rej
My parent always involve in my homework and assignment		550	150	200	100	1000	3.15	Acc
The child's home environment plays an important role in the mathematics performance of the child		650	150	125	75	1000	3.38	Acc
Total		8900	1850	1425	2825	15000	2.99	Acc

From table 1 above, the means score on view of students on influence of environment on their learning and performance in mathematics is above 2.50 on 12 items of the 15 items, and the mean of the 15 items is 2.99. This shows that the environments do influence student's performance in mathematics.

Research Question 2: Does the school environment has any influence on the students' performance in mathematics?

Table 2: Student's View On Influence Of School Environment On Their Performance In Mathematics

Research Question 3: Does the students home environment has any influence on his/her mathematics performance

Table 3. Students View On Influence Of Home Environment On Their Performance In Mathematics

Item	Students view				Total	Mean	Decis
	Strongly agreed	Agreed	Disagreed	Strongly disagreed			
10.	25	100	100	775	1000	1.38	Rej
11.	50	50	100	800	1000	1.35	Rej
12.	600	150	100	150	1000	3.20	Acc
13.	25	50	250	675	1000	1.43	Rej
14.	550	150	200	100	1000	3.15	Acc
15.	650	150	125	75	1000	3.38	Acc
Total	1900	650	875	2575	6000	2.32	Rej

Items 10 to 15 in table 1, answered research question 3. From table 3 above, the mean of mean score is 2.32, which is below 2.50 acceptance level. Therefore the student's home environment has no influence on their performance in mathematics.

Research Hypothesis: There is no any significant difference in the students' view on the influence of school and home environment on their performance in Mathematics.

Table 4: t-Test On Influence Of Environment On Students 'Performance In Mathematics

Type	N	Mean	S.D	df	t-cal	t-critical	Decision
School Environment	1000	3.66	0.198	998	0.030	1.96	Sign
Home Environment	1000	2.32	0.931				

$$t_{998} = 0.030, p < 0.05$$

From table 4 above, the t-calculated of 0.030 is less than the t-critical of 1.96, therefore the hypothesis of there is no difference in the view of students on influence of school and home environment on their performance in mathematics is rejected. This findings show from the students' view that the school environment has greater influence on their performance in mathematics than the home environment. This indicates that the difference of 1.34 in the mean in favour of school environment is significant.

CONCLUSION

The result of this study was able to reveal that the environment has influence on students' performance in Mathematics. More specifically the school environment has greater influence on students' performance in Mathematics, than the home environment. Therefore, students' learning ability is highly connected to the Learning environment.

RECOMMENDATION

Based on the findings from this study ,the following recommendations were made

1. Schools should not be sited around the industrial and market areas. This is to avoid noise and pollution.
2. The school environment needs to be kept good with good ventilation, vegetation and all the necessary social amenities to be present in the school.
3. The student's home environment to be conducive for learning by establishing home library and the parent to always make sure that they motivate their children/wards to do their homework and assist them where necessary.

REFERENCES

- Aikenhea, .T. (1996) Environmental illumination and human behaviour: the effects of spectrum light source on human performance in a university setting. *Italia N.Y* Cornell University press.
- Olonade ,G.B (2001) Influence of school location ,school size, sex difference and Teachers variables on Mathematics .Achievement of secondary students in Kwara state. *Unpublished Master thesis. University of Ilorin, Nigeria.*
- Owitti , .T.(2001) Influence of fluorescent on hyperactivity and learning disabilities *Journal of Learning disabilities, PP 22-27*
- Romer, M.M(1993) Building conditions ,parental involvement, and students achievement in the DC public school system. *Unpublished Master thesis ,Georgetown University, Washington D.C*

CEBİRSEL MUHAKEME DEĞERLENDİRME ARACI: ARAÇ GELİŞTİRME, GÜVENİRLİK VE GEÇERLİK ÇALIŞMASI

ALGEBRAIC REASONING EVALUATION TOOL: TOOL DEVELOPMENT, THE STUDY OF RELIABILITY AND VALIDITY

Deniz KAYA
Dokuz Eylül Üniversitesi, Eğitim Bilimler Enstitüsü
denizkaya50@yahoo.com

Doç. Dr. Cenk KEŞAN
Dokuz Eylül Üniversitesi, Buca Eğitim Fakültesi
cenk.kesan@deu.edu.tr

ÖZET: Bu araştırmanın amacı ilköğretim yedinci sınıf öğrencilerinin cebirsel muhakeme becerilerini değerlendirmeye yönelik bir ölçme aracı geliştirmektir. Cebirsel muhakeme değerlendirme aracının geliştirilmesinde öncelikle alan taraması yoluyla benzer durumdaki araçların nasıl geliştirildiğine yönelik çalışmalar incelenerek ölçme aracın boyutları belirlenmiştir. Daha sonra her bir boyut için madde havuzu oluşturulmuştur. Oluşturulan bu havuz içerisinde uygun görülen maddeler seçilerek 210 yedinci sınıf öğrencisine uygulanmıştır. Uygulama sonucunda elde edilen veriler kapsamında ölçme aracının geçerlik ve güvenilirlik çalışmaları gerçekleştirilmiştir. Güvenirlik çalışması olarak, cronbach alfa iç tutarlılık katsayısı, test-tekrar test güvenilirlik katsayısı ve madde analizi sonuçları değerlendirilmiştir. Geçerlik çalışması olarak da kapsam ve yapı geçerlikleri incelenmiştir. Belirtilen analizler neticesinde ölçme aracından elde edilen ölçümlerin geçerli ve güvenilir olduğuna karar verilmiştir.

Anahtar sözcükler: cebirsel muhakeme, geçerlik, güvenilirlik

ABSTRACT: The aim of this study is to develop a measurement tool for assessing algebraic reasoning skills of seventh grade students. Firstly, in the development of the algebraic reasoning assessment tool, the sub-dimensions of the measurement tool was determined by analysing researches about how similar tools developed by using field scanning. Later, an item pool was created for each sub-dimension. The items which were chosen from the pool for the reason that they were seen as suitable were applied to 210 seventh grade students. The validity and reliability studies of the measurement tool were carried out by using data obtained from the application. The results of cronbach's alpha coefficient of internal consistency, test-retest reliability coefficients and item analysis were evaluated within the scope of reliability studies. Content and construct validity were analysed within the scope of validity studies. As a result of the mentioned analysis, it was decided that the measurements obtained from the measurement tool is valid and reliable.

Key words: algebraic reasoning, validity, reliability.

GİRİŞ

Cebir, cebirsel düşünme ve muhakeme edebilme becerilerinin bir ön koşulu olarak düşünüldüğünde sadece bir ders konusundan ziyade günlük hayatta karşılaştığımız güçlüklerle karşı çözüm yolları bulmamıza yarayan bir araç olarak ele alınması gerekmektedir. Çünkü öğrencilerin cebirde başarılı olabilmeleri için kullanılan temel kavramları, sembolleri, ifadeleri iyi anlaması ve kullanabilmesi gerekir (Kieran, 1992). Nitekim 1989 yılında, aralarında Ulusal Araştırma Konseyi (National Research Council, [NRC]) ve Ulusal Matematik Öğretmenleri Konseyinin (National Council of Teachers of Mathematics, [NCTM]) de bulunduğu birçok kuruluş, cebir için fonksiyonel bir yaklaşımın da içinde bulunduğu, cebirsel düşünme ve muhakeme becerisine vurgu yapan bir cebir müfredatının geliştirilmesine yönelik reform çağırısında bulundu (Nilklad, 2004:1). Bu reformun sloganı ise çok sayıda öğrenciye cebiri daha iyi öğretmek, onları cesaretlendirerek cebir öğrenmeye teşvik etmektir. Matematik müfredatının yeniden yapılandırılmasına yönelik bu atılım sayesinde, öğrencilerin cebirsel düşünme ve muhakeme becerilerinin gelişiminde önemli ilerlemeler sağlanmış, erken yaşta cebirsel fikirleri temsil eden değişik türdeki araçlara olan erişim kolaylaşmış, cebirsel beceriler ve anlayışların hızlanmasına paralel olarak geliştirilen düşünceler birçok alanda uygulama fırsatı bulmuştur (NCTM, 2000). Muhakeme kavramı ise Peresini ve Webb (1999)'a göre çeşitli düşünme tarzlarından oluşan bir faaliyettir. Yackel ve Hanna (2003), muhakemeyi hem tümevarım, tümdengelim, ilişkilendirme ve çıkarsamanın kullanımı hem de öğrenenlerin

problemleri çözmek için birbirleriyle etkileşime geçtikleri ortak bir faaliyet alanı olarak tanımlamışlardır. Cebirsel muhakeme ise genellikle matematiksel muhakemenin önemli bir formunu oluşturmaktadır (Nilklad, 2004). Bir başka ifade ile cebirsel muhakeme nicel durumları göstererek değişkenler arasındaki ilişkiyi açık hale getirebilme kapasitesidir (Driscoll, 1999). Kaput (1994) göre cebirsel muhakeme; bilerek genellemeler yapma, araştırma ve varsayımda bulunma, modellerin ve düzenlerin temsiline yönelik yapılan süreçlerin inşasıdır. Aynı zamanda cebirsel muhakeme kavramı çeşitli temsillerle modellenen problemlerin ve örüntülerin genellendiğinde matematiksel süreçlerin tanımlanmasında kullanılır (Driscoll, 1999; NCTM, 2000). Bu çalışmada, ilköğretim yedinci sınıf öğrencileri için cebirsel muhakeme değerlendirme aracı geliştirilmiş, geliştirilen ölçme aracının geçerlik ve güvenilirlik ile ilgili izlenen süreçler ele alınmıştır.

YÖNTEM

Çalışma Grubu

Araştırmanın çalışma grubunu, İzmir ili Buca ilçe merkezinde bulunan 4 farklı devlet ortaokulunda öğrenim gören 210 yedinci sınıf öğrencisi oluşturmaktadır.

Cebirsel Muhakeme Değerlendirme Aracı

Cebirsel Muhakeme Değerlendirme Aracının geliştirilmesinde Gibson (2005) tarafından ortaya konulan üç aşama kullanılmıştır. Birinci aşamada, kullanılacak aracın geliştirilebilmesi için literatür taraması yoluyla hem matematiksel hem de cebirsel muhakemenin değerlendirilmesi amacıyla gerçekleştirilmiş olan araştırmalar incelenmiştir. İkinci aşamada, cevap formatlarının belirlenmesi, soru bankasının oluşturulması, kapsam geçerliliğin sağlanması, her bir madde içerisinde yer alan belirsizliğin belirlenerek giderilmesi ve maddelerin geniş bir örneklem grubuna uygulanması olmak üzere beş adımda gerçekleştirilmiştir. Üçüncü aşamada ise madde analizi, path analizi ve ölçme aracından elde edilen ölçümlerin güvenilirlik çalışması yapılmıştır.

Kavramın Tanımlanması

Öncelikle literatürde muhakemenin değerlendirilmesi ile ilgili yapılmış çalışmalar incelenerek ölçme aracının boyutları belirlenmiştir. NCTM (2000) muhakeme becerilerini; muhakeme ve ispat kategorileri ile birlikte ele almaktadır. NAEP (2002) muhakeme becerilerine problem çözme becerisi ve matematiksel güç içerisinde yer vermekte, Bloom'un sınıflamasında muhakeme becerileri; sentez ve değerlendirme gibi üst basamaklar karşılamaktadır (Suzuki, 1998). TIMMS (2003) muhakeme becerilerini; analiz, genelleme, sentez, karar verme ve rutin olmayan problemleri çözme kategorileri içerisinde tanımlamakta, MEB (2009) ise muhakeme becerilerini akıl yürütme becerisi olarak ele almaktadır.

Tablo 1. Cebirsel Muhakeme Değerlendirme Aracının Boyutları ve Soru Sayılarının Dağılımı

Araç Boyutları		Beceri Sayısı ve Oranları	
		f	%
Ana- liz	Cebirsel yapıları/ilişkileri tanıma ve kullanma	10	23,8
	Aynı verinin farklı cebirsel ifadelerini kullanma	3	7,1
	Uygun cebirsel muhakemeyi belirleme	7	16,7
Cebirsel ifadelerle yönelik çıkarımda bulunma		6	14,3
Çıkarıma yönelik cebirsel işlemler yapma		4	9,5
Sonucun doğruluğuna ve çözüm yoluna karar verme		5	11,9
Rutin olmayan problemleri çözme		7	16,7
Toplam		42	100

Maddelerin Geliştirilmesi

Literatür taraması sonucunda, ölçme aracının belirlenen her bir boyutu için NCTM, NAEP, TIMMS ve MEB tarafından ortaya konulmuş olan değerlendirme ile ilgili ölçütler ve veri toplama araçları dikkate alınmıştır. Araçta öğrencilerin cebirsel muhakeme yetenekleri ile ortak ve alana özgü becerilerin, duyuşsal özelliklerin, öz düzenleme ve psikomotor becerilerini ortaya çıkarabilecek açık uçlu sorular ile ölçme aracının kapsam geçerliliğinin sağlanması amacıyla çoktan seçmeli tipte soruların kullanılmasına karar verilmiştir.

Psikometrik Ölçümler: Güvenirlik Çalışmaları

a) İç Tutarlılık Katsayısı

Hesaplanan iç tutarlılık katsayısı için de genel kabul en az 0,70 olmasıdır (Büyüköztürk, 2003; Özçelik, 2010; Pilten, 2008). Ölçüm sonuçlarına göre Cronbach-Alfa güvenilirlik katsayısı 0,93 olarak hesaplanan ölçme aracının katsayısı 0,70'in üzerindedir.

b) Test-Tekrar Test Güvenirliği

Test-tekrar test güvenirlilik çalışması amacıyla cebirsel muhakeme değerlendirme aracı, deneme uygulaması yapılmış olan 210 öğrenciden tesadüfi olarak seçilmiş olan 30'una 3 hafta sonra tekrar uygulanmıştır. Öğrencilerin iki uygulamadan almış oldukları puanlar için hesaplanan Pearson Momentler Çarpımı Korelasyon Katsayısı 0,77 olarak hesaplanmıştır. Bu sonuç, ölçme aracının test-tekrar test ölçüm güvenirliliğine de sahip olduğunu göstermektedir.

c) Madde Analizi

Değerlendirme aracında yer alan, çoktan seçmeli soru tipinde olan maddelerin madde analiz işlemleri için "Finesse" adlı test analiz programı kullanılmıştır. Cebirsel muhakeme değerlendirme aracında yer alan açık uçlu soruların madde ayırt edicilik ve güçlük indekslerinin hesaplanmasında ise Öncü (1999)'ün belirtmiş olduğu formüllerden yararlanılmıştır.

Tablo 2. Cebirsel Muhakeme Değerlendirme Aracında Yer Alan Maddelere Ait Madde Güçlük ve Ayırt Edicilik Gücü İndeksleri

Boyut	Soru Tipi	Soru No	Güçlük İneksi (pj)	Ayırt Edicilik (dj)
Cebirsel yapıları/ilişkileri tanıma ve kullanma	Ç. S.	1	0.60	0.61
	Ç. S.	2	0.79	0.61
	Ç. S.	3	0.71	0.52
	Ç. S.	4	0.78	0.67
	Ç. S.	5	0.28	0.06*
	Ç. S.	6	0.74	0.56
	Ç. S.	7	0.66	0.71
	Ç. S.	8	0.68	0.74
	Ç. S.	9	0.46	0.28*
	Ç. S.	10	0.73	0.69
Aynı verinin farklı cebirsel ifadelerini kullanma	Ç. S.	11	0.49	0.61
	Ç. S.	12	0.66	0.71
	Ç. S.	13	0.46	0.27*
Uygun cebirsel muhakemeyi belirleme	A. U.	14	0.73	0.42
	A. U.	15	0.75	0.39
	A. U.	16	0.68	0.47
	A. U.	17	0.64	0.45
	A. U.	18	0.77	0.46
	A. U.	19	0.64	0.47
	A. U.	20	0.66	0.45
Cebirsel ifadelere yönelik çıkarımda bulunma	Ç. S.	21	0.63	0.43
	Ç. S.	22	0.41	0.37
	Ç. S.	23	0.61	0.40
	Ç. S.	24	0.59	0.58
	Ç. S.	25	0.71	0.41
	Ç. S.	26	0.50	0.48
Çıkarıma yönelik cebirsel işlemler yapma	A. U.	27	0.46	0.66
	A. U.	28	0.46	0.70
	A. U.	29	0.56	0.72
	A. U.	30	0.55	0.74
Sonucun doğruluğuna ve çözüm yoluna karar verme	A. U.	31	0.42	0.60
	A. U.	32	0.48	0.82
	A. U.	33	0.56	0.70
	A. U.	34	0.46	0.77
	A. U.	35	0.50	0.71
Rutin olmayan problemleri çözme	A. U.	36	0.66	0.55
	A. U.	37	0.43	0.73
	A. U.	38	0.68	0.42
	A. U.	39	0.63	0.58
	A. U.	40	0.64	0.49
	A. U.	41	0.63	0.49
	A. U.	42	0.64	0.28*

Madde güçlük indeksinin 0,50 olması sorunun orta güçlükte olduğunu gösterir (Atılğan, Kan ve Doğan, 2007). Tablo 2 incelendiğinde cebirsel muhakeme değerlendirme aracında yer alan maddelerinin çoğunluğunun orta güçlük ve orta güçlüğü yakın değerlerde olduğu görülmektedir. Ayırıcı gücü 0,40 veya daha yüksek olan maddeler "çok iyi", 0,30 ile 0,40 arasında olanlar "iyi" maddelerdir. Ayırıcı gücü 0,20 ile 0,30 arasında olan maddeler zorunlu ise kullanılmalı; pozitif olmakla birlikte 0,20'den düşük olanlar mutlaka geliştirilmelidir. Testte, ayırıcı gücü negatif olan, ters ayırım yapan maddelere hiç yer verilmemelidir (Özçelik, 1992:220). Tablo

2'e göre, maddelerin çoğunluğunun madde ayırt edicilik güçleri bakımından oldukça iyi oldukları söylenebilir. Ancak 5, 9 13 ve 42 sorularının ayırt edici indeksleri bakımında düşük olmasından dolayı araçtan çıkarılması uygun görülmüştür. Söz konusu soruların araçtan çıkarılmasıyla güvenirlik katsayısı 0,94 olarak bulunmuştur.

Geçerlik Çalışması

Araştırmada kullanılan “Cebirsel Muhakeme Değerlendirme Aracının” geçerliği kapsam ve yapı geçerlikleri yoluyla test edilmiştir.

Kapsam Geçerliği

İçerik geçerliği ölçeğin, bütünü ve alt boyutlarının ölçülmek istenen alanı ölçüp ölçmediğini ve ölçülecek alan dışında farklı kavramları barındırıp barındırmadığını değerlendirmek amacıyla yapılır (Gözüm ve Aksayan, 2003:10). Bu amaçla geçerlik işlemleri sırasında ölçme aracı boyutlarının birbiriyle olan ilişkilerinin belirlenmesinde Pearson Momentler Çarpımı Korelasyon Katsayısı kullanılmıştır (Tablo 3). Her bir boyutun ölçme aracı ile olan ilişkisinin belirlenmesinde ise regresyon katsayılarından yararlanılmıştır (Tablo 4).

Tablo 3. Modele İlişkin Korelasyon Matrisi

	CYİTK	AVFCİK	UCMB	CİYÇB	ÇYCIY	SDÇYKV	ROPÇ
CYİTK	1,000						
AVFCİK	,735	1,000					
UCMB	,693	,641	1,000				
CİYÇB	,632	,631	,631	1,000			
ÇYCIY	,634	,660	,635	,643	1,000		
SDÇYKV	,629	,679	,646	,586	,673	1,000	
ROPÇ	,580	,597	,588	,587	,614	,651	1,000

Tablo 4. Modele İlişkin Standardize Edilmiş Regresyon Katsayıları

	Regresyon Katsayısı	P
CMDA → CYİTK	.872	.000
CMDA → AVFCİK	.824	.000
CMDA → UCMB	.847	.000
CMDA → CİYÇB	.804	.000
CMDA → ÇYCIY	.822	.000
CMDA → SDÇYKV	.827	.000
CMDA → ROPÇ	.794	.000

(CMDA: Cebirsel Muhakeme Değerlendirme Aracı, CYİTK: Cebirsel yapıları/ilişkileri tanıma ve kullanma AVFCİK: Aynı verinin farklı cebirsel ifadelerini kullanma, UCMB: Uygun cebirsel muhakemeyi belirleme, CİYÇB: Cebirsel ifadelere yönelik çıkarımda bulunma, ÇYCIY: Çıkarıma yönelik cebirsel işlemler yapma, SDÇYKV: Sonucun doğruluğuna ve çözüm yoluna karar verme, ROPÇ: Rutin olmayan problemleri çözme)

Tablo 3 incelendiğinde ölçme aracı boyutları arasında en yüksek ilişkinin “cebirsel yapıları/ilişkileri tanıma ve kullanma” ile “aynı verinin farklı cebirsel ifadelerini kullanma” arasında ($r=0,735$), en düşük ilişkinin ise “cebirsel yapıları/ilişkileri tanıma ve kullanma” ile “rutin olmayan problemleri çözme” ($r=0,580$) arasında olduğu görülmektedir. Sonuç olarak araç boyutları arasındaki ilişki göz önüne alındığında Cebirsel Muhakeme Değerlendirme Aracının kapsam geçerliğinin olduğu söylenebilir.

Yapı Geçerliği

Yapı geçerliği, bir ölçeğin ve ondan elde edilen puanın gerçekte ne anlama geldiğini araştırma sürecidir. Bu süreç, ölçeğin ölçtüğü faktörler incelenerek ya da geçerliği araştırılan ölçeğin diğer ölçek ve ölçülerle olan ilişkisini araştırarak gerçekleştirilir (Gözüm ve Aksayan, 2003:11). Tablo 5’de mükemmel ve iyi uyum değerleri, modelin geçerli sayılabilmesi için uyum testlerine ait değerlerin bulunması gereken aralıkları göstermektedir (Çokluk ve diğer.,2010). Cebirsel muhakeme modeline ilişkin elde edilen değerler ise deneme uygulaması sonunda model uyum testlerinden alınan puanları ifade etmektedir.

Tablo 5. Model Uyum İndeksi ve Modele İlişkin Değerler

Uyum İndeksi	Mükemmel Uyum	İyi Uyum	Cebirsel Muhakeme Modeline Ait Değerler
x^2 / sd	$0 \leq x^2 / sd \leq 2$	$2 \leq x^2 / sd \leq 3$	1.404
RMSEA	$0 \leq RMSEA \leq 0.05$	$0.05 \leq RMSEA \leq 0.08$	0.044
AGFI	$0.95 \leq AGFI \leq 1.00$	$0.90 \leq AGFI \leq 0.95$	0.901
NNFI	$0.95 \leq NNFI \leq 1.00$	$0.90 \leq NNFI \leq 0.95$	0.940
IFI	$0.95 \leq NFI \leq 1.00$	$0.90 \leq NFI \leq 0.95$	0.950

CFI	$0.95 \leq CFI \leq 1.00$	$0.90 \leq CFI \leq 0.95$	0.950
-----	---------------------------	---------------------------	-------

(χ^2 / sd / sd: Ki-Kare Değerinin Serbestlik Derecesine Oranı, RMSE: Yaklaşık Hataların Ortalama Karekökü İndeksi, AGFI: Ayarlanabilir İyilik Uyum İndeksi, NNFI: Normlaştırılmamış Uyum İndeksi, IFI: Artmış Uyum İndeksi, CFI: Karşılaştırmalı Uyum İndeksi)

SONUÇLAR

Öncelikle ilk formdan oluşan 42 maddelik ölçme aracından elde edilen ölçümlerin Cronbach Alfa güvenilirlik katsayısı hesaplanarak 0,93 olarak, daha sonra da ayırt edicilik indeksi ideal değerinde olan 4 madde çikartıldığında Cronbach Alfa güvenilirlik katsayısı 0,94 olarak bulunmuştur. Bu sonuç aracın iç tutarlılık katsayısı bakımından ölçüm sonuçlarının güvenilir olduğunu göstermektedir. Yapılan analizler sonucunda aracın Test-Tekrar Test Güvenirlik katsayısı 0,77 olarak bulunmuştur. Bu sonuç literatürde bir testin güvenilir kabul edilebilmesi için gereken en küçük değerdeden (0,70) büyük olduğunu göstermektedir. Finesse programı yardımıyla yapılan madde analizi sonucunda 38 maddenin ayırt edicilik indeksinin oldukça iyi ve iyi, 4 maddenin de düzeltilmeye ve geliştirilmeye muhtaç ve zayıf olduğu görülmektedir. Ayrıca LISREL 8.72 programı ile her bir alt boyutun, birbirleriyle ve tüm testle olan ilişkisine bakıldığında aracın kapsam geçerliğinin olduğu görülmektedir. Aracın yapı geçerliğine ilişkin değerler incelendiğinde ise uyum testlerinden elde edilen puanların iyi uyum ile mükemmel uyum aralıklarında olduğu görülmektedir.

NOT: Bu çalışma, 2013.KB.EĞT.009 nolu proje kapsamında Dokuz Eylül Üniversitesi Bilimsel Araştırma Projeleri Koordinasyon Birimi tarafından desteklenen, ikinci yazar danışmanlığında, birinci yazar tarafından hazırlanan “Çoklu Temsil Temelli Öğretimin Öğrencilerin Cebirsel Muhakeme Becerilerine, Cebirsel Düşünme Düzeylerine ve Matematığe Yönelik Tutumlarına Etkisi Üzerine Bir İnceleme” isimli doktora çalışmasının bir bölümünü oluşturmaktadır.

KAYNAKLAR

- Atılğan, H., Kan, A. ve Doğan, N. (2007). *Eğitimde ölçme ve değerlendirme*. Ankara: Anı yayıncılık.
- Büyüköztürk, Ş. (2003). *Sosyal bilimler için veri analizi el kitabı*. Ankara: Pegem a yayıncılık.
- Çokluk, Ö., Şekercioğlu, G. ve Büyüköztürk, Ş. (2010). *Sosyal bilimler için çok değişkenli istatistik: SPSS ve LISREL uygulamaları*. Ankara: Pegem akademi yayıncılık.
- Driscoll, M. (1999). *Fostering algebraic thinking: a guide for teachers grades 6-10*. Portsmouth, NH: Heinemann.
- Gibson, T. L. (2005). Development of an instrument to assess student attitudes toward educational process in an undergraduate core curriculum. Unpublished doctoral dissertation, University of Arkansas.
- Gözüm, S. ve Aksayan, S. (2003). Kültürlerarası ölçek uyarlaması için rehber II: psikometrik özellikler ve kültürlerarası karşılaştırma. *Hemşirelikte Araştırma ve Geliştirme Dergisi*, 5(1), 3-14.
- Kaput, J. J. (1994). The representational roles of technology in connecting mathematics with authentic Experience. In R. Biehler, R. W. Scholz, R. Strasser, & B. Winkelmann (Ed.), *Didactics in mathematics as a scientific discipline* (pp. 379-397). Netherlands: Kluwer academic publishers.
- Kieran, C. (1992). The learning and teaching of school algebra. in: groups DA (ed.). *Handbook of research on mathematics teaching and learning*. New York: Macmillan publishing company.
- Milli Eğitim Bakanlığı (MEB) (2009). *İlköğretim matematik dersi 6-8. sınıflar öğretim programı ve kılavuzu*. Ankara: MEB.
- National Assessment of Educational Practices (NAEP) (2002). *Mathematics framework for the 2003 national assessment of educational progress*. Washington, DC: National Assessment Governing Board.
- National Council of Teachers of Mathematics (NCTM) (2000). *Principles and standards for school mathematics*. Reston, VA: National Council of Teacher of Mathematics.
- Nilkılad, L. (2004). College algebra students' understanding and algebraic thinking and reasoning with functions. Unpublished doctoral dissertation, Oregon State University.
- Öncü, H. (1999). *Eğitimde ölçme ve değerlendirme*. Ankara: Yaysan A. Ş.
- Özçelik, D. A. (2010). *Test hazırlama kılavuzu*. Ankara: PegemA yayıncılık.
- Özçelik, D. A. (1992). *Ölçme ve değerlendirme*. Ankara: ÖSYM yayınları.
- Peresini, D. & Webb, N. (1999). *Analyzing mathematical reasoning in students' responses across multiple performance assessment tasks*. Developing mathematical reasoning in grades K-12/Lee V. Stiff, 1999 Yearbook Editör, National Council of Teachers of Mathematics, Reston, Virginia.
- Pilten, P. (2008). Üstbiliş stratejileri öğretiminin ilköğretim beşinci sınıf öğrencilerinin matematiksel muhakeme becerilerine etkisi. Yayınlanmamış doktora tezi, Gazi Üniversitesi, Eğitim Bilimler Enstitüsü.
- Suzuki, K. (1998). Measuring “to think mathematically”: cognitive characterization of achievement levels in performance-based assessment. Unpublished doctoral dissertation, University of Illinois, Urbana.
- TIMSS, (2003). IEA's TIMSS 2003 international report on achievement in the mathematics cognitive domains: findings from a developmental project international association for the evaluation of educational achievement. *TIMSS & PIRLS International Study Lynch School of Education*, Boston College.

Yackel, E. & Hanna, G. (2003). *Reasoning and proof*. In J. Kilpatrick, G. Martin and D. Schifter (Ed.), *A research companion to principles and standards for school mathematics* (pp. 227-236). Reston, VA: National Council of Teachers of Mathematics.

TEACHING THE FUTURE TEACHERS: MAKING SCIENCE RELEVANT, USEFUL AND MEANINGFUL FOR NEW ZEALAND PRE-SERVICE TEACHERS

Steven S. SEXTON
University of Otago
steven.sexton@otago.ac.nz

ABSTRACT: This self-study investigated how one teacher educator and his final-year pre-service teachers perceived the primary science classroom learning environment. The study utilized the Nature of Science as Argumentative Questionnaire (NSAAQ) and regularly scheduled focus group interviews. These tools investigated how the learning environment the teacher educator created effectively modelled the pedagogical approaches stated in *The New Zealand Curriculum*. The initial NSAAQ results indicated where the pre-service teachers' understanding of the nature of science were naïve and what aspects needed to be addressed over the course of the programme. Focus group sessions revealed how student teachers' science attitudes altered over their course of study. These pre-service teachers reported they are now more confident to teach science and that their teacher educator influenced their anticipated teaching practices. The findings support the explicit inclusion of the effective pedagogy approaches from the curriculum. This research supports the importance of self-study in initial teacher education.

Key words: Primary science, Teacher education, Self-study

INTRODUCTION

A number of challenges for the New Zealand educational system in primary science have been reported (Bull, Gilbert, Barwick, Hipkins, & Baker, 2010; Education Review Office, 2012; Gluckman, 2011). All of these reports note that while there are some noteworthy science teaching practices, there are more issues regarding ineffective science teaching. Many of the challenges for primary school science are neither new to New Zealand nor to many other countries (Ginns & Watters, 1995; Prenzel, Seidel, & Kobarg, 2012).

Teacher quality is one of the main means to address the challenges in primary science education (Gluckman, 2011). But how is a quality primary school teacher prepared for education in science? It has been noted that how teachers are prepared for the classroom during their university education is a good indicator of how well they may eventually teach (Darling-Hammond, 1999; Education Review Office, 2010; Rice, 2003). Within initial teacher education (ITE) programmes, two influences need to be considered when evaluating future teacher quality: the teacher educator (Cochran-Smith, 2003); and, if the pre-service teachers practice teaching using the pedagogy learned during their coursework (Hudson & Skamp, 2002).

Teacher educators create the classroom learning environments in which pre-service teachers experience learning and teaching. How then do teacher educators and their classroom learning environments contribute to the multi-faceted educational picture of primary science teacher preparation? Does the teacher educator's practice and created learning environment influence how final-year student teachers may eventually teach primary science?

The purpose of the present study was an investigation into how the researcher, as teacher educator, and his final-year undergraduate pre-service teachers understood the programme's targeted primary science. The research scrutinized which aspects of the researcher's classroom practices influenced the pre-service teachers' pedagogical understandings of primary science. The study explicitly sought to identify the extent to which the student teachers' perceived how the classroom modeled *The New Zealand Curriculum's* (Ministry of Education, 2007) effective pedagogy approaches.

Why Teacher Educators?

Who teaches the teachers how to teach? This task is given to teacher educators (Cameron & Baker, 2004). Even though teacher educators are an important aspect of teacher education, research literature indicates we are an often-neglected group in research studies. Little research has focused on the quality or expertise of teacher educators (Cameron & Baker, 2004; Smith, 2005).

The present study focused on the practice of one teacher educator, the researcher, and how he worked to develop science pedagogical understandings in seventeen final-year undergraduate pre-service teachers. As teacher

educators are responsible for providing pre-service teachers with strong foundations of professional teaching knowledge, the researcher wanted to inform his own teaching practice.

Why Effective Pedagogy As Defined In *The New Zealand Curriculum*?

The New Zealand Ministry of Education introduced a dramatically revised integrated curriculum document in 2007 compared to the previous curriculum documents (Benade, 2009). Included in the 2007 curriculum are seven pedagogical approaches that teachers are encouraged to incorporate into their own teaching practice. These are creating a supportive learning environment; encouraging reflective thought and action; enhancing the relevance of new learning; facilitating share learning; making connections to prior learning and experience; providing sufficient opportunities to learn; and, teaching as inquiry. The curriculum document notes that these pedagogies are based on a wide body of evidence about what positively impacts student learning (Ministry of Education, 2007). Pre-service teachers, therefore, need first authentic exposure to and then practical experience in these approaches in order to be able to incorporate them into their own teaching practice.

METHODOLOGY

To address the research question, this self-study research project used a mixed method framework (Lunenberg, Zwart, & Korthagen, 2010; Russell, 2010). Mixed method is a methodology often used in learning environment studies and has proven to be effective (Aldridge, Fraser, Taylor, & Chen, 2000; Pickett & Fraser, 2002).

Nature Of Science As Argument Questionnaire

The researcher selected the Nature of Science as Argument Questionnaire (NSAAQ) for the present study, see Appendix. The NSAAQ developed by Sampson and Clark (2006) measures key aspects of participants' epistemological understanding of the nature of scientific knowledge. The NSAAQ provides information on four specific aspects of the nature of science. These are the nature of scientific knowledge; how scientific knowledge is generated; how that knowledge is evaluated; and science as a socially and culturally embedded practice. The questionnaire has proven validity (Sampson & Clark, 2006).

The survey was administered by the researcher at the beginning of the first session of the programme to establish an understanding of what these final year pre-service teachers understood about the nature of science. For this ITE programme, student teachers are required to take a compulsory introductory course in science in their first-year of their undergraduate programme. As part of their final-year of study, student teachers are required to take Literacy and Numeracy plus two additional curriculum learning areas of their choice, of which science is one option. This programme is delivered over ten two-hour tutorials.

Focus Group Sessions

Focus group sessions were used to elicit pre-service teachers understandings of Shulman's (1986) theoretical constructs of pedagogical content knowledge (PCK). PCK is generally seen as a combination of general pedagogical knowledge and subject matter knowledge (Gess-Newsome, 1999). Content knowledge (CK) by contrast, is defined as the subject matter that is taught and how it is organised in the teacher's mind (Shulman, 1986). Teacher educators need both knowledge types to develop in pre-service teachers as teachers draw on these knowledge constructs to know what to teach and how to teach it. As the NSAAQ examined what aspects of the nature of science these pre-service teachers understood, the focus group sessions evaluated what pedagogy individuals understood from the course and if it reflected the effective pedagogy approaches from *The New Zealand Curriculum* document. The focus group sessions were a regular part of their university coursework and each averaged 25 minutes of the two-hour tutorials.

The researcher conducted all sessions, as these were a part of their science education course. The transcripts were continuously reviewed for themes that emerged by analytic induction (Erickson, 1986). Analytic induction is a way to sift through the narrative data, first coding for general themes. One of the themes the transcribed interviews were coded for were indications of how the researcher's/teacher educator's primary science course was impacting on pre-service teachers' pedagogy. After coding for general themes, each general theme was then analysed again until a more detailed pattern emerged. The detailed themes that emerged from the data were then linked, when possible, to *The New Zealand Curriculum's* effective pedagogy to formulate an overall understanding of what was taught by the teacher educator and what was perceived by pre-service teachers.

Participants

Participants for this study were from one undergraduate programme of study at a large university in New Zealand. All 17 student teachers enrolled in the 2014 final-year science curriculum studies course voluntarily participated in this study. The ten two-hour sessions were face-to-face tutorials. Participants were 18-years or older, of which 15 were female and two male, see Table 1:

Table 1: Participants' Self-Identified Demographic Data from NSAAQ

Total surveys	17
Female	15
Male	2
NZ European	17
18-20-years	2
21-25-years	10
26-29-years	4
30 + years	1

Science Education Programme

The present study's science programme was a ten-session course of study in the first semester of 2014. The student teachers who enrolled into this science paper did so voluntarily. These student teachers were informed that they would be required to create a unit of study on a primary science topic as the assessment requirement for this course. During this final-year of study, the student teachers spent one-day a week in a school as part of their professional learning experience. At the completion of this course, the student teachers had two weeks to prepare for a three-week block placement of sustained control teaching of this same class. It is anticipated that the student teachers will use their unit of work while on this sustained teaching placement, but this is not a course requirement.

On the first day of the science education course, the teacher educator informed the student teachers that the course science content would be determined by their input. As this course requires the student teachers to build a unit of work based on the interests and abilities of their teaching placement classroom, their science education facilitator would model this. The student teachers brought to the second tutorial the science topics they wanted the course to include; see Table 2.

Table 2: Teaching and Learning Schedule

Week	Course Content	Explicit Nature of Science – New Zealand Curriculum	Explicit Nature of Science pedagogy	Explicit effective pedagogy - <i>The New Zealand Curriculum</i>
1	Agar jelly dishes: using science to explain school/class rules	Reviewing <i>The New Zealand Curriculum's</i> science learning area: Nature of Science and the four Content Strands	The nature of scientific knowledge	Creating a supportive learning environment
2	Cool bombs: common kitchen ingredients	How Investigating in Science and Understanding about Science link	How scientific knowledge is generated	Encouraging reflective thought and action
3	Mini-beasts: how to investigate the Living World, ethics of science	The importance of students being able to use the correct vocabulary to talk about science	How scientific knowledge is evaluated	Enhancing the relevance of new learning
4	Change of State: how the Physical World is different from the Material World	Relating the science to students' everyday world	How scientific knowledge is generated	Facilitating shared learning
5	Gardening	Using both Living World and Planet Earth to demonstrate Participating and Contributing	Science as a culturally and socially embedded practice	Making connections to prior learning and experience
6	Space	Effective and models to Investigate in science using Planet Earth and Beyond	The nature of scientific knowledge	Providing sufficient opportunities to learn
7	Planet Earth: Volcanoes, Tornados, Weather	How Earth behaves and how to incorporate appropriate vocabulary for students	Science as a culturally and socially embedded practice	Encouraging reflective thought and action; Making connections to prior learning and experience
8	Games	Types of fun that facilitate student learning about their world	How scientific knowledge is evaluated	Facilitating shared learning; Providing sufficient opportunities to learn
9	Electricity	Integration of all four elements of the curriculum's Nature of Science	How scientific knowledge is generated	Teaching as inquiry
10	Explosions	Integration of all four elements of the curriculum's Nature of Science	Science as a culturally and socially embedded practice	Teaching as inquiry

RESULTS

Each question of the NSAAQ presents two contrasting views of the nature of science, a naïve and an informed perspective. A five-point scale separates the two statements (Sampson, 2006). The NSAAQ survey includes at least five questions addressing each of the four identified aspects. Quantifiable data from the NSAAQ surveys was analysed using the Statistical Package for the Social Sciences (SPSS) version 21.0. The consistency of the responses among the participants' responses to the individual NSAAQ items was calculated by using Cronbach alpha coefficient as 0.64 for the initial test and .71 for the second test that indicated that the questionnaire had sufficient internal consistency (Gliem & Gliem, 2003).

NSAAQ And Scoring Descriptions

In scoring the responses to the NSAAQ survey, a naïve view was taken as a response of 1, 2 or 3, while an informed view was taken as a score of 4 or 5. This decision was based on the premise that participants who selected 3 for their response to any of the NSAAQ questions were unable to make a distinction between the two views (Sampson, 2006). The mean, standard deviation and percentage of respondents who selected 1, 2 or 3 for each question was calculated (see Table 3, below). The range of the means for the initial-test questions was from 1.51 to 4.55, while the range of the second-test was 2.59 to 4.94.

Table 3: Student Teachers' views of Nature of Science

NSAAQ	M	SD	% answering 1, 2, or 3	M	SD	% answering 1, 2, or 3
	Initial-test			Second-test		
1	2.3	1.27	82.3	2.59	.64	70.6
2	2.89	1.19	47.1	3.71	.64	35.3
3	3.75	0.97	29.4	4.06	.49	0
4	4.21	0.41	0	4.41	.56	0
5	2.22	0.92	88.2	2.88	.75	58.8
6	3.93	1.22	29.4	4.94	.73	0
7	3.01	0.89	82.4	3.47	.66	47.1
8	4.42	0.49	0	4.53	.50	0
9	2.56	0.67	100	2.88	.83	82.3
10	1.90	0.71	100	2.59	.92	88.2
11	2.48	0.85	100	3.17	.96	70.6
12	1.51	0.67	100	3.29	.80	58.8
13	3.32	0.78	70.6	3.24	.84	70.6
14	3.08	0.77	82.4	3.94	.40	41.2
15	3.63	1.23	29.4	4.88	.39	0
16	2.85	1.16	82.4	3.18	.97	58.8
17	3.01	0.89	70.6	4.12	.85	11.8
18	3.92	0.83	23.5	3.35	.59	17.6
19	4.13	0.72	23.5	4.24	.46	0
20	2.71	1.19	70.6	2.76	.78	64.7
21	2.72	0.94	70.6	3.29	.89	58.8
22	2.63	0.66	100	2.94	1.22	64.7
23	3.76	1.00	29.4	4.41	.67	0
24	2.91	0.83	70.6	3.00	1.00	58.8
25	4.11	0.87	17.6	4.71	.46	0
26	4.55	0.50	0	4.94	.30	0
Overall	3.15	0.87		3.67	.70	

The researcher decided to calculate the percentage of respondents who indicated 1, 2, or 3 for each question as this provided an indication of the percentage of respondents holding naïve views. The range for the percentages

for the initial test was from 0 to 100%. This identified the five questions where all of these student teachers held naïve views, see questions 9, 10, 11, 12 and 22.

Overall, these student teachers held naïve views for 12 of the 26 pre-test questions. This indicated what the teacher educator needed to prepare in the course material that would address both the student teachers' pedagogical content knowledge in effective science education and the nature of science aspects covered by questions 9, 10, 11, 12 and 22. At the completion of this programme, these student teachers held naïve views for only 6 of the 26 questions which included questions 9, 10 and 22.

Effective Pedagogy Approaches

As *The New Zealand Curriculum* highlights seven effective pedagogical approaches, the researcher wanted to investigate how well these teaching approaches were reflected in the data analyses. Creating a supportive learning environment recognises that learning is social and cultural process. Students learn better when they part of a positive classroom environment (Ministry of Education, 2007). This approach was noted by almost all the student teachers as one of the strengths of the course. One student noted, "I have really enjoyed science and have particular liked how you designed the course so that what we learnt was relevant for our teaching practice." These student teachers really appreciated the amount of control they had over course content. This was commented upon by most of these student teachers, for example, "it was helpful to be able to choose the topics we covered in the classes." When asked to explain how this was helpful, this student teacher added, "these are topics that are useful to us as these are what our mentor [classroom teacher hosting the student teacher] want us to teach."

As part of the learning environment, these student teachers had multiple opportunities to develop and reflect on their own and others' ideas in scaffold opportunities of reflective thought and action (Ministry of Education, 2007). These student teachers commented that the classroom was a learning environment that not only encouraged them to question the teacher educator's plans, methods and ability to explain concepts but also to develop their own ideas with each other. Support for these approaches was observed during the hands-on science activities used in class sessions that then had the student teachers reflect and discuss what they thought they knew and what actually occurred. It should be noted that some activities elicited significantly more reflection and frustration than others did, for example, it was anticipated that many of these student teachers would find it difficult to use models to demonstrate the orbit of the Moon and explain a near total lunar eclipse was going to be visible from New Zealand on April 15th, 2014. The Moon's orbit provided these student teachers an opportunity to reflect critically on how activities are able to lead to deeper thinking. As effective and appropriate use of models to stimulate critical reflective thought and discussion is an area where these student teachers needed more support, they were informed that they would need to include in their unit plans how and where they were going to encourage their students to engage in critical reflection.

The learning classroom environment cultivates shared learning and reflective discourse (Ministry of Education, 2007). The teacher educator, using both small group and whole group discussions, supported these approaches as classes developed the language of teaching as well as the language used in science by engaging in hands-on science activities. *The New Zealand Curriculum* places the Nature of Science as the overarching strand of science in New Zealand. It should be noted that the Nature of Science (capital letters) is different from the nature of science (lower case letters). In New Zealand, the Nature of Science includes understanding about science, investigating in science, communicating in science, and, participating and contributing. Teachers use appropriate science content to expand their students' worlds through the Nature of Science. Teachers, therefore, need to provide the opportunities to allow students to ask questions about the science they are doing, use the appropriate vocabulary necessary to talk about the science they are doing and understand how this science relates to their world. As one student teacher commented, "I found it [this course] very helpful in the sense that you learnt how to teach science." When asked to clarify what she meant, she went on to state, "science is students using the correct words to questioning each other, to question the science and question me as the teacher." In this same focus group session, another student teacher remarked that she found out that it was, "ok for a teacher not to know everything" and that one can, "learn from your students" which were attitude shifts from how she learned science in school.

Students' learning is supported when new knowledge is incorporated with what they already know and connections can be made to other learning areas (Ministry of Education, 2007). This teaching approach was supported with pre-service teachers commenting on how science could be ordinary things from their everyday life. They noted how to use activities that students would be able to connect to their own lives, such as batteries, rubber bands, paper clips, and metal cans to make a toy that returns to the child when rolled away.

Students' deeper learning is facilitated when they understand what, why and how they could use their new learning; that is enhancing the relevance of new learning having the opportunities to learn (Ministry of Education, 2007). This was best represented when one student commented that after the session on weather (see session 7, Table 2) he now understood how and why thunder occurs. Even better, in the focus group session for session 8, he talked about doing the previous week's thunder activity with his teaching experience class and how with a piece of paper he showed his students and mentor in less than 30-minutes, "how cool science can be." As stated, in this programme student teachers were explicitly involved in making their own learning decisions. More than one student teacher was pleased that what was being taught was what they could use in their own unit planning or weekly teaching; for example, "I liked how each class covered a different aspect of science, based on what anyone needed or was going to need in their upcoming practicum."

The teacher educator modelled in the course and made explicit examples of how the programme content was reviewed and adjusted using evidence-based strategies. This was done so the student teachers were aware of when the teacher educator was implementing inquiry into the teaching and learning relationship (Ministry of Education, 2007). As stated, the student teachers were required to plan a science unit that was anticipated they would teach. They were instructed that as part of their planned unit they would be assessed on how well they linked lessons and built on the conceptual understandings of their students. This was done to support the pre-service teachers need for structured assistance to understand how to challenge ideas and assess student learning. Not all of the student teachers appreciated this emphasis on modelling what, how and why in learning.

One student teacher rated the course very well and noted that, "Steve always put 100% into every lesson, which was interesting and hands on for us the students." This same student teacher then commented that I was supportive and helpful with the assessment tasks, but not as helpful and supportive in class. It would appear for at least this one student teacher a ten-week course was not long enough in showing her the importance of challenging what she thought she knew about science. Not only did she comment negatively on having her ideas challenged by the course but also she did not alter her naïve position for NSAAQ questions 9, 10, 11, 12 or 22.

CONCLUSIONS

The NSAAQ was developed to address concepts of the nature of science, and to provide a tool that could be used to discriminate between how the nature of science is viewed. In addition to identifying participants' nature of science understanding, the individual questions provided a tool to highlight the specific nature of science concepts to explore within the tutorials in order to enhance each individual's understanding.

Semi-structured focus group sessions supported how student teachers' perceptions changed over the course. Overall, these student teachers did move to a more positive attitude towards how to teach primary science than when they started the course and linked this to the teacher educator's enthusiasm and passion for the topic. As teacher dislike of science is a reason why some students are not taught science (Sexton, Atkinson & Goodson, 2013), the shift to a more positive attitude towards science by these student teachers is encouraging.

During the focus group sessions, the student teachers commented on how the teacher educator modelled the science teaching practices they were expected to use. The student teachers, however, indicated that more work on their part was required before they would feel as confident in their teaching practice. This supports research that student teachers need to experience effective pedagogy for it to be incorporated in their own PCK (Stofflett & Stoddart, 1994).

One aspect of the primary science course that these student teachers commented on was that after being introduced to effective pedagogy through science education, they wanted more practice in using it. Many of these student teachers stated, "I feel much more confident in teaching science now" as they felt much better prepared by this course to teach science. However, once student teachers are in a teaching position, research indicates it was difficult for them to implement the pedagogy they learnt at university as they coped with full-time responsibilities of a classroom (Sexton, Atkinson & Goodson, 2013).

Hands-on activities were used during the coursework and the use of activities like these was stated as a key pedagogical approach that shaped how many of the student teachers would begin to teach science in their own classrooms. This is a positive outcome as it indicates these student teachers intend to implement a more student centred approach to hands-on science. However, how well and how often these student teachers will actually use hands-on activities once they are classroom teachers is not known. As the reality of limited school resources, teacher preparation and setup time, as well as scheduling time for science teaching impacts beginning teachers

(Education Review Office, 2012), follow-up research is required to indicate if high quality hands-on activities are actually used.

Another concern that might affect the student teachers' science pedagogy is the emphasis on literacy and numeracy. This emphasis on literacy and numeracy is a reason given in the 2010 Education Review Office report as to why primary science teaching time has waned in schools. Other researchers have reported that when science is not considered important by teachers or is assigned a low priority compared to other subjects like literacy and numeracy, little time is spent teaching it (Education Gazette, 2009; Roden, 2000).

Effective pedagogies should be taught not only in science but also across all subject areas during the pre-service teachers' education. ITE providers should review what is taught throughout the teaching degree programmes and evaluate if effective pedagogies are taught, linked and explicitly made known to student teachers. As New Zealand's Ministry of Education is interested in having these approaches utilised by its teachers, more research into the application of the approaches as well as student and in-service teacher professional development in the use of the approaches would be required. As these effective pedagogical approaches are not just for the curriculum area of science, educational opportunities in how to use them effectively is necessary.

RECOMMENDATIONS

Teachers are the key to a quality education as they are the link between curriculum, pedagogy, assessment, and social and learning outcomes (Jones & Baker, 2005). Primary school teachers who can effectively develop these links in the learning area of science are needed (Gluckman, 2011). But it is difficult to achieve a positive link for New Zealand primary students when many of their primary school teachers are uncomfortable with teaching science (Education Review Office, 2010, 2012; Lewthwaite, 2000).

An important element in teacher education is the teacher educator. Teacher educators convey all aspects of *The New Zealand Curriculum* to include both necessary content knowledge and pedagogical content knowledge. Therefore, teacher educators need to know which parts of their practice are influencing pre-service teachers. Teacher educators should not assume that the concepts taught and modelled during primary science coursework are understood, nor that in the future they will be integrated into the teaching pedagogy of the student teachers once they are in a classroom situation.

REFERENCES

- Aldridge, J., Fraser, B., Taylor, P., & Chen, C. (2000). Constructivist learning environments in a crossnational study in Taiwan and Australia. *International Journal of Science Education*, 22(1), 37-55. doi:10.1080/095006900289994
- Benade, L. (2009). The New Zealand draft curriculum 2006: A policy case study with specific reference to its understanding of teaching as an ethical profession. *Policy Futures in Education*, 7(1), 5-19. doi:10.2304/pfie.2009.7.1.5
- Bull, A., Gilbert, J., Barwick, H., Hipkins, R., & Baker, R. (2010). *Inspired by science*. Wellington, NZ: New Zealand Council for Educational Research.
- Cameron, M., & Baker, R. (2004). *Research on initial teacher education in New Zealand 1993-2004-Literature review and annotated bibliography*. Wellington, New Zealand: New Zealand Council for Education Research.
- Cochran-Smith, M. (2003). Learning and unlearning: the education of teacher educators. *Teaching and Teacher Education*, 19(1), 5-28. doi:10.1016/S0742-051X(02)00091-4
- Darling-Hammond, L. (1999). *Teacher quality and student achievement: A review of state policy evidence*. Seattle, WA: Center for the study of Teaching and Policy, University of Washington.
- Education Gazette. (2009). Making the most of science: A call to action. *Education Gazette*, 88(16), 6-7.
- Education Review Office. (2010). *Science in years 5 to 8: Capable and competent teaching*. Wellington, New Zealand: Education Review Office. Retrieved from <http://www.ero.govt.nz/National-Reports/Science-in-Years-5-to-8-Capable-and-Competent-Teaching-May-2010/Overview>
- Education Review Office. (2012). *Science in the New Zealand curriculum: Years 5 to 8*. Wellington, New Zealand: Education review Office. Retrieved from <http://ero.govt.nz/National-Reports/Science-in-The-New-Zealand-Curriculum-Years-5-to-8-May-2012>
- Erickson, F. (1986). Qualitative methods in research on teaching. In M. Wittrock (Ed.), *Handbook of research on teaching* (3rd ed., pp. 119-161). New York, NY: Macmillian.

- Gess-Newsome, J. (1999). Pedagogical content knowledge: An introduction and orientation. In J. Gess-Newsome & N. Lederman (Eds.), *Examining pedagogical content knowledge* (pp. 3-17). Dordrecht, The Netherlands: Kluwer Academic.
- Ginns, I., & Watters, J. (1995). An analysis of scientific understandings of preservice elementary teacher education students. *Journal of Research in Science Teaching*, 32(2), 205-222. doi:10.1002/tea.3660320209
- Gliem, J. A., & Gliem, R. R. (2003). Calculating, interpreting, and reporting Cronbach's alpha reliability coefficient for Likert-type scales. Paper presented at the Midwest Research-to-Practice Conference in Adult, Continuing and Community Education, The Ohio State University, Columbus, OH, October 8-10.
- Gluckman, P. (2011). *Looking ahead: Science education for the twenty-first century*. Wellington, New Zealand: Office of the Prime Minister's Science Advisory Committee.
- Hudson, P., & Skamp, K. (2002). Mentoring Preservice Teachers of Primary Science. *Electronic Journal of Science Education*, 7(1). Retrieved from <http://ejse.southwestern.edu/article/view/7692/5459>
- Jones, A., & Baker, R. (2005). Curriculum, learning and effective pedagogy in science education for New Zealand: Introduction to special issue. *International Journal of Science Education*, 27(2), 131-143. doi:10.1080/0950069042000276686
- Lewthwaite, B. (2000). Implementing science in the New Zealand curriculum: How teachers see the problem. In G. Haisman (Ed.), *Exploring issues in science education* (pp. 11-22). Wellington, New Zealand: Research and Curriculum Divisions.
- Lunenberg, M., Zwart, R., & Korthagen, F. (2010). Critical issues in supporting self-study. *Teaching and Teacher Education*, 26(6), 1280-1289. doi:10.1016/j.tate.2009.11.007
- Ministry of Education. (2007). *The New Zealand Curriculum*. Wellington, New Zealand: Learning Media.
- Pickett, L., & Fraser, B. (2002). *The role of learning environment, achievement, and student and teacher attitudes in a science mentoring program for beginning elementary school teachers*. Paper presented at the annual meeting of the American Educational Research Association, New Orleans, LA, April 1-5.
- Prenzel, M., Seidel, T., & Kobarg, M. (2012). Science teaching and learning: An international comparative perspective. In B. Fraser, K. Tobin & C. McRobbie (Eds.), *Second international handbook of science education* (vol 1, pp. 667-678) Dordrecht, The Netherlands: Springer.
- Rice, J. (2003). Executive Summary/Chapter 1. In *Teacher Quality - Understanding the Effectiveness of Teacher Attributes* (pp. v-7). Retrieved from http://www.epi.org/publication/books_teacher_quality_execsum_intro/
- Roden, J. (2000). Primary science: A second-class core subject? In J. Sears & P. Sorensen (Eds.), *Issues in science teaching* (pp. 31-40). London: Routledge Falmer.
- Russell, T. (2010). Self-study by teacher educators. In P. Peterson, E. Baker & B. McGaw (Eds.), *International Encyclopedia of Education* (3rd ed., pp. 689-694). Amsterdam, The Netherlands: Elsevier.
- Sampson, V. (2006). *The nature of science as argument questionnaire (NSAAQ)*. Paper presented at the National Association for Research in Science Teaching (NARST) Annual Meeting, San Francisco, CA, April 3-6.
- Sampson, V. D., & Clark, D. B. (2006). *The development and validation of the nature of science as argument questionnaire (NSAAQ)*. Paper presented at the National Association for Research in Science Teaching (NARST) Annual Meeting, San Francisco, CA, April 3-6.
- Sexton, S. S., Atkinson, J., & Goodson, R. (2013). Narratives of place: Provisional teachers' experiences in science. *Science Education International*, 24(3), 361-376.
- Shulman, L. (1986). Those who understand: Knowledge growth in teaching. *Educational Researcher*, 15(2), 4-14.
- Smith, K. (2005). Teacher educators' expertise: What do novice teachers and teacher educators say? *Teaching and Teacher Education*, 21, 177-192. doi:10.1016/j.tate.2004.12.008
- Stofflett, R., & Stoddart, T. (1994). The ability to understand and use conceptual change pedagogy as a function of prior content learning experience. *Journal of Research in Science Teaching*, 31(1), 31-51. doi:10.1002/tea.3660310105

APPENDIX:

Nature of Science as Argumentative Questionnaire (NSAAQ)

Directions: Read the following pairs of statements and then circle the number on the continuum that best describes your position on the issue described. The numbers on the continuum mean:

1 = I completely agree with viewpoint A and I completely disagree with viewpoint B

2 = I agree with both viewpoints, but I agree with viewpoint A more than I agree with viewpoint B

3 = I agree with both viewpoints equally

4 = I agree with both viewpoints, but I agree with viewpoint B more than I agree with viewpoint A

5 = I completely agree with viewpoint B and I completely disagree with viewpoint A

What is the nature of scientific knowledge?

When you think of the body of knowledge that has been generated by the work of scientists, how would you describe it? The statements below describe scientific knowledge from different viewpoints.

	Viewpoint A	A not B	A>B	A=B	B>A	B not A	Viewpoint B
1	Scientific knowledge describes what reality is really like and how it actually works.	1	2	3	4	5	Scientific knowledge represents only one possible explanation or description of reality.
2	Scientific knowledge should be considered tentative.	1	2	3	4	5	Scientific knowledge should be considered certain.
3	Scientific knowledge is subjective.	1	2	3	4	5	Scientific knowledge is objective.
4	Scientific knowledge does not change over time once it has been discovered	1	2	3	4	5	Scientific knowledge usually changes over time as the result of new research and perspectives
5	The concept of 'species' was invented by scientists as a way to describe life on earth.	1	2	3	4	5	The concept of 'species' is an inherent characteristic of life on earth; it is completely independent of how scientists think.
6	Scientific knowledge is best described as being a collection of facts about the world.	1	2	3	4	5	Scientific knowledge is best described as an attempt to describe and explain how the world works.

How is scientific knowledge generated?

When you think of what scientists do in order to produce scientific knowledge, how would you describe this process?

The statements below describe different viewpoints for how scientific knowledge is generated.

	Viewpoint A	A not B	A>B	A=B	B>A	B not A	Viewpoint B
7	Experiments are important in science because they can be used to generate reliable evidence.	1	2	3	4	5	Experiments are important in science because they prove ideas right or wrong.
8	All science is based on a single scientific method	1	2	3	4	5	The methods used by scientists vary based on the purpose of the research and the discipline.
9	The methods used to generate scientific knowledge are based on a set of techniques rather than a set of values.	1	2	3	4	5	The methods used to generate scientific knowledge are based on a set of values rather than a set of techniques.
10	Science is best described as a process of exploration and experiment.	1	2	3	4	5	Science is best described as a process of explanation and argument.
11	An experiment is used to test an idea.	1	2	3	4	5	An experiment is used to make a new discovery.
12	Within the scientific community, debates and discussions that focus on the context, processes, and products of inquiry are common.	1	2	3	4	5	Within the scientific community, debates and discussions that focus on the context, processes and products of inquiry are rare.

What counts as reliable and valid scientific knowledge?

A central claim of science is that it produces reliable and valid knowledge about the natural world.

The statements below describe different viewpoints about what counts as reliable and valid scientific knowledge.

	Viewpoint A	A not B	A>B	A=B	B>A	B not A	Viewpoint B
13	Scientific knowledge can only be considered trustworthy if the methods, data, and interpretations of the study have been shared and critiqued.	1	2	3	4	5	Scientific knowledge can be considered trustworthy if it is well supported by evidence.
14	The scientific method can provide absolute proof.	1	2	3	4	5	It is impossible to gather enough evidence to prove something true.
15	If data was gathered during an experiment it can be considered reliable and trustworthy.	1	2	3	4	5	The reliability and trustworthiness of data should always be questioned.
16	Scientists know that atoms exist because they have made observations that can only be explained by the existence of such particles.	1	2	3	4	5	Scientists know that atoms exist because they have seen them using high-tech instruments.

	Viewpoint A	A not B	A>B	A=B	B>A	B not A	Viewpoint B
17	Biases and errors are unavoidable during a scientific investigation.	1	2	3	4	5	When a scientific investigation is done correctly errors and biases are eliminated.
18	A theory should be considered inaccurate if a single fact exists that contradicts that theory.	1	2	3	4	5	A theory can still be useful even if one or more facts contradict that theory.
19	Scientists can be sure that a chemical causes cancer if they discover that people who have worked with that chemical develop cancer more often than people who have never worked that chemical.	1	2	3	4	5	Scientists can only assume that a chemical causes cancer if they discover that people who have worked with that chemical develop cancer more often than people who have never worked that chemical.

What role do scientists play in the generation of scientific knowledge?

The statements below describe different viewpoints for what scientists do and what they are like.

	Viewpoint A	A not B	A>B	A=B	B>A	B not A	Viewpoint B
20	In order to interpret the data they gather scientists rely on logic and their creativity and prior knowledge.	1	2	3	4	5	In order to interpret the data they gather scientists rely on logic only and avoid using any creativity or prior knowledge.
21	Scientists are influenced by social factors, their personal beliefs, and past research.	1	2	3	4	5	Scientists are objective, social factors and their personal beliefs do not influence their work.
22	Successful scientists are able to use the scientific method better than unsuccessful scientists.	1	2	3	4	5	Successful scientists are able to persuade other members of the scientific community better than unsuccessful scientists.
23	Two scientists (with the same expertise) reviewing the same data will reach the same conclusion.	1	2	3	4	5	Two scientists (with the same expertise) reviewing the same data will often reach different conclusions.
24	A scientist's personal beliefs and training influence what they believe counts as evidence.	1	2	3	4	5	What counts as evidence is the same for all scientists.
25	The observations made by two different scientists about the same phenomenon will be the same.	1	2	3	4	5	The observations made by two different scientists about the same phenomenon can be different.
26	It is safe to assume that a scientist's conclusions are accurate because they are an expert in their field.	1	2	3	4	5	A scientist's conclusion can be wrong even though scientists are experts in their field.

NO YOUTH LEFT BEHIND: REFLECTIONS FROM UNDERGRADUATE MATHEMATICS

Ersin İLHAN
Bayburt University
eilhan@bayburt.edu.tr

ABSTRACT: With the initiative of Council of Higher Education (HEC), all graduates from high schools almost have a chance to take a place in undergraduate programs because of the newly founded universities in all cities in Türkiye. The problems arise in the first year of higher education for the students who have not enough competences in mathematics. The program's courses in universities are similar but the enrolled students in programs are not homogeneous in their mathematics backgrounds. No Youth Left Behind (NYLB) in placement is achieved for schooling purposes, but is it reasonable to say NYLB in first year mathematics is achieved. Thus, the aim of study is to find the way for achievement in transition and first year mathematics in higher education. In order to accomplish the aim, the head of mathematics department in citywide should be co-head with the head of departments at university.

Key words: Undergraduate Mathematics, Function, Transition

INTRODUCTION

With the initiative of HEC in Türkiye, all graduates from high schools almost have a chance with 74,86% gross schooling (TÜİK, 2014) and their chances will be increased by newly founded higher education institutions in the following years, to take a place in undergraduate programs only with ranking system in entrance examination without considering academic abilities of candidates. That's why the process of placement can be called a continuation instead of transition from high school to higher education.

Increasing higher education schooling to get enough places at universities for the high school graduates can be thought as the democracy of equality in reaching the higher education and building socially well environments. By the years pass away, the ratio of continuing tertiary education increases as Sewell & Hauser (1972) states that a student in the high socioeconomic status category has a 2,5 times greater chance of continuing his or her education beyond high school than one in the low socioeconomic status category whereas Hoffman, Vargas and Santos, (2009) state that young people from middle- and upper-income families are five times more likely to earn a two- or four-year college degree than those from low-income families. Tanrikulu (2011) states principle factors for increasing higher education schooling ratios as employment and its impact on income and also population at age of higher education. The stated findings constitute the reasons of growing number of universities to form socially well prepared societies, taking low socioeconomic students into consideration. From this point there is no problem in No Youth Left Behind (NYLB) Act. The problems arise in the first year of higher education with students who have not enough competences in mathematics. The program's courses in all universities are almost similar but the students in programs are not homogeneous in their backgrounds in mathematics. NYB in placement is achieved, but is it reasonable to say No Youth Left Behind in first year mathematics achievement. In the study, No Youth Left Behind is investigated from two perspectives; one is from high school to university and the other is from university to anywhere but not the following year at the university.

This state of students' feeling is explained by rite of passage and Mutch (2005) see transition as the process you go through mentally when you face a big life change, and recognizes the first year of higher education experience as an identifiable period of transition. In this study, I examined the period from high school to university exam and from there to the first year of higher education from the point of "rites of passage". Theory is combined with the lens of mathematics, how the transition period is experienced by students from the line of mathematics. Transition period includes three phases as Clark and Lovric (2008) explains; Separation (from high school) takes place while students are still in high school, and includes anticipation of forthcoming university life; Liminal (from high school to university) includes the end of high school, the time between high school and university, and the start of first year at a university and Incorporation (into university) includes, roughly, first year at a university. When separation and incorporation phases are thought together Clark and Lovric (2008) asks for what to teach students to prepare them for university and the other asks for finding effective ways of students' prerequisite knowledge can be found not only at the liminal phase as a question of

“how can we prepare students in the separation phase so that they can study / review functions” that is also needed at higher education level. Then the problem of curriculum gap arises in the form of continuing or background about the functions to be studied at higher education. The curriculum gap is explained by Brandell, Hemmi and Thunberg (2008) as students’ abilities to draw accurate sketches of elementary functions are below what is expected.

Liminal phase considering the university examination, the similar history can be found in Japanese higher education system. Increasing number of universities lowers the level of students and importance of the university exam and produces the new problem of students without enough competencies to be seat at the first year of university courses (Mori, 2002). When transition and curriculum gap are introduced together, the aim of study is to find the way for achievement in transition and first year mathematics in higher education

METHODS

In this study, to minimize the curriculum gap, at the beginning of the course the functions are review from the perspective of modelling. Modelling contributes towards giving more meaning to the learning and teaching of mathematics (Blum, 1993). In the first step of this study, the 42-students of Bayburt University in economics program of Faculty of Economics and Administrative Sciences are introduced learning model activities (group learning and problem solving) and students’ task papers are analysed under the implementation of quantitative approach.

The transition period from the students’ view can be understand as to find a place but then the emerging problems linking high school and first year at the university arises in so many different levels that need to be overcome for the sake of our nation’s young generation. To reveal the existing situation, students’ thoughts in first year mathematics are investigated in qualitative approach. In the second step, the same students’ thought about the education in high school, in higher education and the process of Student Selection and Placement System (OSYS) are obtained using the open questioned survey to get their feelings about all aspects of the transition period.

Curriculum Gap; Functions

High school mathematics program (NME, 2005) aims to develop eight significant mathematics skills of students. In this study, two of them, problem solving and modelling, are taken in to consideration to use concrete link between high school and higher education. The transition period links students’ mathematical knowledge between high school and higher education in modelling using functions. Modelling is taught for the revision of functions that students should be familiar from high school mathematics lessons. The problem, in lesson plan, which includes the skills named modelling, problem solving and topic of function, given in the mathematics program is “In meteorology, the balloon is inflated with helium gas and with related rate of 1.5 cm/sn. Find the function of volume V in terms of time t ?” (NME, 2005, p.41). It is used to get idea of students’ mathematics level and use that information to form groups in problem solving activity. The implementation of the problem solving approach with the problem task given in the math class as a group work is “when you turn on a hot-water faucet, the temperature T of the water depends on how long the water has been running. Draw a rough graph of T as a function of time t that has elapsed since the faucet was turned on” (Stewart, 2009, p.15).

The problem task is formed with Polya’s five steps in problem solving evaluation approach (Baki, 2006); Understanding Problem, Making Plan, Implementation of Plan, Evaluation and Making New Problem, with voluntarily formed 2-person groups of total 42. The task is distributed to groups as mentioning to work alone at the beginning of activity and later on to work as a group for the prerequisite of group working. At last, they share their solutions to whole class by writing them on the blackboard. After all, I combine all solutions by negotiating with students to draw the common result for the task problem. Groups’ papers are evaluated according to the problem solving evaluation scale Baki (2006).

Transition

The transition period’s phases are to be asked to students at survey. For each phase, one open ended question is used to get students’ inner thought during the whole transition period. The questions and the responses are evaluated to get the idea of situation that students face as rite-of-passages. For separation phase, high school period, “What are your experiences about mathematics in high school?”, for liminal phase, the period from high school to university, implies the university exam, waiting for results, making the selection for placement according to points and ranking in exam, the question “What are you experiences about OSYS?” and for

incorporation phase, includes the first year in the university, the question is “What are you experiences about mathematics at university?”.

RESULTS AND FINDINGS

The Function

The students draw their solution on the blackboard to see all in one shot to analyze as a class and two of them are given in Figure 1. The graphs are different in detail but when you look them to get the pattern, there are some similar ones. Even they can be grouped according to their similarities. This is caused by the problem text that the value of temperature is not given and they choose their own values.

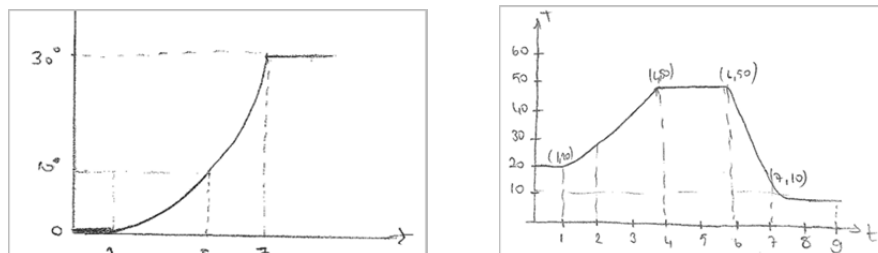

Figure 1. Samples of Students’Works

The problem solving evaluation scale, according to analyzing of task papers, findings and their descriptive statistics at level three are given in Table 1 with all steps in Polya’s problem solving process that are evaluated with five dimensions. With 71%, it is known that students have a difficulty of understanding problem in the perspectives of rewriting them in a different way. 60% of students have the difficulty in forming strategy to lead solving problem. Whatever their strategy is, students try to calculate and graph something with 45%. Backward study on the solution steps or in giving arguments to verify the solution steps, there are no such task papers. In making new problem with the logic of the given one, there are no great efforts but only 40%. In problem solving evaluation steps with five dimensions, implementation of plan works better besides the others.

Table 1. Problem Solving Evaluation Scale

Problem Solving Evaluation Process	n	%
Understanding Problem	12	29
Making Plan	17	40
Implementation of Plan	19	45
Evaluation	-	-
Making New Problem	17	40

Groups’ tasks finding in Table 1 emphasis the weakness of students’ problem solving skill that are aimed in high school and also in higher education.

The Transition Period

For the transition period survey findings are given in three phases. Separation phase (Figure 2), all the responses are coded and then categorized under three themes; high school type, mathematics lesson and mathematics teacher. High school type; I see myself in lack of knowledge graduated from vocational high school, need to shadow education, prepares us to university examination. Mathematics lesson; more about memorization, not oriented to university examination, not related to university mathematics topics, mathematics topics are not completed, topics in high school mathematics should be similar to university examination. Mathematics teacher; I wonder what happens if someone from HEC comes to any of the high school’s any mathematic lesson, university teachers should have classes in high schools.

Liminal phase (Figure 2), all responses are categorized under two themes; system and placement. System; we are experimental subject, having not enough information about the system, tiring empty brains. Placement; I do not know but when I see my community, everybody seems to be placed in any university, do not know how

OSYS place students, no placement according to abilities, nobody is in the university that they wish, no examination but place everybody where they want.

Incorporation phase (Figure 2), all responses are categorized under four themes; mathematics exams, mathematics topics, mathematics teacher and class attendance. Mathematics exams; examinations are difficult, the entire fault is not our, because it is known that we are not good at mathematics, we are not mathematicians so easy questions. Mathematics topics; not see the mathematics topics in high school, study topics from economics perspective, should start from lower levels that we do not know. Mathematics teacher; understand topics because teach well, teaches for understanding not for memorization. Class attendance; when attend the class I understand, where is the problem; math education which is not given us in high school or OSYS which places us at university with such a mathematics knowledge or students who do not put enough effort to get the knowledge. Class is considered as of phase so there linkage with phases.

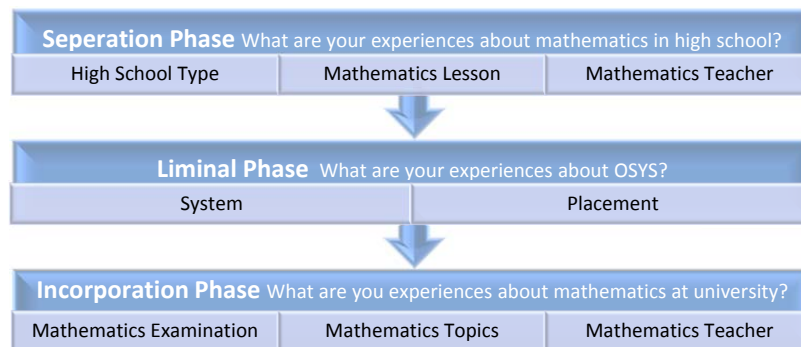

attendance
inner source
is no
other

Figure 2. Transition Period

The phases of transition period are interlinked in three main issues as shown in the same column (Figure 2.). The first is, high school type, system-placement and mathematics examination reveals importance of school type and OSYS and their effects on undergraduate mathematics examination. The second is, mathematics lesson in high school and mathematics topics in university is explained by disconnection. The third is, mathematics teacher in both class presents the method used in teaching. Hence, the link among phases are set by the students is line to carry out the remedial education.

CONCLUSION

The mathematics levels of students in modelling task of the functions (Table 1.) reveals the weakness of the understanding, making plan, evaluation and making a new problem that are the dimensions of the problem solving process. It is strange that understanding and making new problem have same percentages explains without understanding there is nothing to do. Beside these, implementation of the strategy whatever they choose shows the greatest percentage as 45% can be understand as students just know to do some manipulation even without knowing what they are doing, which represents the term “memorization”. The findings shows that OSYS places every graduate at higher education from the socially well-being generation perspectives but OSYS should think also the cognitive states and needs of the students as well.

To avoid the disadvantages of shadow education for students, higher education institutions should find the ways as “remedial education” to help first year students for their academic achievements. Mori (2002) states that higher education institutions make students’ transitions smooth and one major issue under dispute is who is responsible for remedial education. Otherwise, after first year in higher education NYLB will be accomplished as not passing the following year means that it is the end of university life.

RECOMMENDATIONS

It is concluded that each youth should have a right to study in higher education by providing not only more places for them but also preparing them to be ready to study in higher education. As Mori (2002) states who is responsible for remedial education especially the ones coming from the disadvantaged high school such as vocational, implies that there should be close and immediate cooperation between NME and HEC, opposite to giving majority of responsibility to high school (HEC, 2007), about findings ways of strengthening students' cognitive level even starting from kindergarten to higher education. In order to accomplish this cooperation, the head of mathematics departments in citywide should be co-head with the head of departments at university.

REFERENCES

- Baki, A. (2006). *Kuramdan Uygulamaya Matematik Eğitimi*. Trabzon: Derya Kitabevi.
- Blum, W. (1993). Mathematical modelling in mathematics education and instruction. Inside *Teaching and learning mathematics in context*, Edited by Breiteig (etc.), (pp.3–14). Ellis Horwood Limited, Chichester.
- Brandel, G., Hemmi, K., & Thunberg, H. (2008). The Widening Gap – A Swedish Perspective. *Mathematics Education Research Journal*, 20(2), 38–56.
- Clark, M. & Lovric, M. (2008). Suggestions for a Theoretical Model for secondary –Tertiary Transition in Mathematics. *Mathematics Education Research Journal*, 20(2), 25–37.
- HEC (2007). *Türkiye'nin Yükseköğretim Stratejisi*. Ankara: Yükseköğretim Kurulu.
- Hoffman, N., Vargas, J., & Santos, J. (2009). New Directions for Dual Enrollment: Creating Stronger Pathways from High School Through College. *New Directions For Community Colleges*, 145: 43–58.
- Mori, R. (2002). Entrance examination and remedial education in Japanese higher education. *Higher Education*, 43, 27–42.
- Mutch, C. (2005). The Transition from High School to University: An Analysis of Advice for Students, Faculty and Administration. Received March 24, 2014 from <http://www.cshe.nagoya-u.ac.jp/publications/journal/no5/10.pdf>
- NME (2005). *Matematik Dersi Öğretim Programı ve Kılavuzu*. Ankara: Talim ve Terbiye Kurulu Başkanı.
- Psacharopoulo, G. & Tassoulas, S. (2004). Achievement at the higher education entry examinations in Greece: A Procrustean approach. *Higher Education*, 47, 241–252.
- Sewell, H. W. & Hauser, R. M. (1972). Causes and Consequences of Higher Education: Models of the Status Attainment Process. *American Journal of Agricultural Economics*, 54(5), 851–861.
- Sewell, H. W. (1971). Inequality of Opportunity for Higher Education. *American Sociological Review*, 36(5), 793–809.
- Stevenson, D. L. & Baker, D. P. (1992). Shadow Education and Allocation in Formal Schooling: Transition to University in Japan. *The American Journal of Sociology*, 97(6), 1639–1657.
- Stewart, J. (2009). *Calculus*. USA: Cagne Publication.
- Tanrıkulu, D. (2011). *Türkiye'de Yükseköğretime Erişim*. Ankara: Siyaset, Ekonomi ve Toplum Araştırmaları Vakfı Yayını.
- TUİK (2014). Öğretim Yılı ve Seviyelerine Göre Okullaşma Oranı. Received March 24, 2014 from http://www.tuik.gov.tr/PreTablo.do?alt_id=1018

THE DICHOTOMOUS MARKOV PROCESS WITH NONPARAMETRIC TEST APPLICATION; A DECISION SUPPORT METHOD IN LONG-TERM RIVER BEHAVIOURAL ANALYSIS

Mohammad SEPEHRIFA

Shantia YARAHMADIAN

We use the Dichotomous Markov Noise (DMN) model with constant transition rates to describe the dynamics of fluctuations in the water level as a stochastic process, which is imposed on river discharge changes. By applying this model, two different regimes are determined for the long-term behaviour of the river. Based on these regimes, we define two nonparametric classes of the overall increasing/decreasing nature of the water level in the long-term behaviour, which are separated by an exponential steady state regime. In this paper, we develop a nonparametric testing procedure to test exponentially (steady state regime) against an alternative overall decreasing level distribution. The proposed test predicts the long-term regime behaviour of the river. The mathematical tools introduced to handle the problem should be of general use and the testing procedure can be considered as a new mathematical tool in the study of water level dynamics. Under conditions of data austerity and as a case of study, we examine the stochastic characteristics of the Zayandeh Rud River (Isfahan, Iran) water level.

Keywords: DMN, Real-time River Management, Extreme events modeling, Nonparametric Test

FACILITATING STUDENTS' GEOMETRIC THINKING THROUGH VAN HIELE'S PHASE-BASED LEARNING USING TANGRAM

Nyet Moi SIEW

The aim of this study was to determine the effects of Van Hiele's phases of learning using tangrams on 3rd grade primary school students' levels of geometric thinking at the first (visual) and second (analysis) level. The study further investigated if high, moderate, and low ability students acquire better mastery in geometric thinking at the end of tangram activities. Pre-test and post-test single group experimental design was employed in the study. A total of 221 students enrolled in Grade Three during the 2013 educational year formed the sample. The students learned Two-dimensional geometry and Symmetry through the Van Hiele's phases of learning using tangram. A geometric thinking test was administered to students before and after the intervention. The intervention took place for 3 hours. Paired samples t-tests comparing the mean scores of geometric thinking pre-test and the post-test were computed to determine if a significant difference existed. One-way Multivariate analysis of variances (MANOVA) was conducted to compare the students' pretest and posttest mean scores across the three groups:- high, moderate and low ability students. The results found that there were significant differences between pre-test and post-test in students' geometric thinking. It was also found that Van Hiele's phases of learning using tangrams was able to significantly promote geometric thinking in the van Hiele's first (visual) and second (analysis) level among high, moderate and low ability students. Low ability students were observed to have the greatest improvement score compared to moderate and high ability students. Thus, the Van Hiele's phases of learning using tangram can be applied in primary school mathematics to help students achieve better level of geometric thinking

Keywords: Geometric Thinking; Van Hiele's phases of learning; Primary school students, Tangram

EFFECT OF GENDER, AGE AND MATHEMATICS ANXIETY ON COLLEGE STUDENTS' ACHIEVEMENT IN ALGEBRA

Owolabi JOSIAH
josiahowolabi@yahoo.com

Etuk-iren Olubunmi ADEJOKE
olubunmietukiren@yahoo.com

Mathematics/Statistics Department
Federal College of Education (Technical), Akoka, Lagos, Nigeria.

ABSTRACT :Mathematics is a very important subject. It is the language of science and technology and so it is a force to reckon with in the development of any nation. Several studies on factors that affect mathematics achievement have been conducted. However, studies on factors that affect mathematics achievement among College students in Nigeria seems to be rare. This study therefore sought to investigate the effects of gender, age and mathematics anxiety of College students on their achievement in Algebra. The study adopted an ex-post-facto design since no variable was manipulated. The participants of the study are mathematics teacher trainees in the Federal Colleges of Education in Lagos and Ogun states of Nigeria. The data for the study was from a questionnaire which elicited information on gender and age of respondents, a mathematics anxiety scale ($r=0.82$) and participants' achievement score in an Algebra course coded MAT 111. The achievement score in Algebra is the dependent variable while gender, age and mathematics anxiety formed the independent variables of the study. The data collected were analysed using mean, standard deviation, independent t-test and One-way ANOVA. The results of the analyses showed average performance in the Algebra course. Besides, the differences in achievement across gender, age and mathematics anxiety groupings (low, medium and high) were all non-significant. Since the participants are on their first semester in the college and their performance is generally on the average, it is recommended that proper orientation be given to new students on how to be high achievers on the programme. Besides, their lecturers should be as simple as possible in their instructions.

Keywords: Gender, age, anxiety, mathematics, achievement.

INTRODUCTION

Several studies have been conducted over the years to determine the predictors of mathematics achievement among various groups of individuals. Some of the predictors discovered are: socio- economic status (Ajayi & Muraina 2011), students' employment status (Wantanabe, 2005), teaching methods (Eniayeju, 2010), gender and continuous assessment (Owolabi & Etuk –Iren, 2009). Other factors found to affect achievement in mathematics are: self-concept and learning style (Rech & Stevens,1996), reading abilities, mathematics self efficacy and teacher evaluation (Larwin, 2010) and students' previous knowledge (Siegler, Duncan, Davis-Kean, Duckworth, Claessens, Engel, Susperregury and Chen, 2012).

One variable that has, over the years, received considerable attention in many studies on science achievement in general and mathematics achievement in particular is gender. In a meta –analysis of 77 studies conducted between 1980 and 1991 among middle and high school students, DeBaz (1994) found a significant gender effect favouring males in overall science achievement. Hedges and Newell (1999) discovered that boys outperform girls in science but in reading and writing girls have the advantage. Researchers have indicated that gender affects mathematics achievement. For example, Trends in International Mathematics and Science Study (TIMSS), found significant differences between male and female students in mathematics achievement, with male students significantly outperforming their female counterparts. Epstein, Elwood, Hey, Maw (1998) reported that females outperform males in mathematics. In their study, Hedges and Newell(1999) reported that girls perform better than boys in reading and writing. However, a Nigerian study by Abiam and Odok(2006) shows no significant gender-achievement relationship in number and numeration, algebraic process and statistics. Similar results showing no significant gender difference in mathematics achievement were found by Habibollah, Abdullahi, Arizan, Sharir, and Kurma (2009) and Abubakar(2010).

Another variable which is of great interest to this study is age. Many studies have been conducted to investigate the effect of age on students' achievement. White (1982) found that the correlation between age and school

achievement diminishes as students become older. According to White (1982), schools provide equalizing experiences, and thus the longer the students study in the schooling process, the more the impact of the age on students' achievement is diminished. In addition, as the students move up the age, more students drop out of school, thus reducing the magnitude of the correlation. On the contrary, results from longitudinal studies have contradicted White's results by demonstrating that there is a gap in students' achievements as students get older (Walker, Greenwood, Hart & Carta, 1994). La Paro & Pianta (2000) presented evidence that older children fared better academically than the younger ones.

Akman-Yesilel (2012) submits that anxiety is a term used for several disorders that cause nervousness, fear, apprehension and worrying. According to him, these disorders affect the way we feel and behave. Zhang (2004) sees it as a cognitive behaviour rising from self-doubt and self-depreciation. Many students with mathematics anxiety possess little or no confidence in their ability to solve mathematics problems. The pertinent question is what is the level of anxiety which is acceptable and beyond which performance is seriously affected? According to Ashcraft and Kirk (2001), the correlation between mathematics anxiety and academic performance is negatively significant. The findings of Hembree (1990) show that students with a high level of mathematics anxiety have lower levels of mathematics achievement.

Different studies have been conducted to investigate the kind of relationship displayed across several age populations. For example, mathematics anxiety is negatively correlated with mathematics performance among adults among college students in particular (Frary & Ling, 1983). Hembree (1990) reported an average correlation between anxiety and achievement for college students. In their study, Eccles and Jacobs (1986) after introducing gender as a mediating variable found that gender differences in mathematics anxiety are attributable to gender differences in mathematics achievement. Wood (1988) reviewed research on mathematics anxiety manifested among elementary teachers and suggested that mathematics teachers' anxiety towards mathematics was likely to be transmitted to their students.

Studies that investigated the collective and individual influence of age, gender and mathematics anxiety on mathematics in general and Algebra in particular seem to be very rare. On this note, this study seeks to find out the influence of gender, age and mathematics anxiety on achievement in Algebra among NCE mathematics students in south-western Nigeria.

Purpose of the Study

This study will determine:

1. The influence of gender on students' achievement in Algebra
2. The influence of age on students' achievement in Algebra
3. The influence of mathematics anxiety on students' achievement in Algebra

Hypotheses

The following hypotheses were tested:

1. There is no significant difference in the achievements of male and female students in Algebra.
2. There is no significant difference in the achievements of students in Algebra across age groups.
3. There is no significant difference in the achievements of students in Algebra across low, medium and high anxiety groups.

METHOD

The study adopted a survey design with all undergraduate computer/mathematics students of the Federal colleges of education in Lagos and Ogun states of Nigeria as population for the study. The sampling procedure was purposive as students who had offered the Algebra course in their first semester year one were eligible to participate in the study. The mathematics anxiety rating scale was administered on one hundred and sixty computer/mathematics students of Federal College of Education (Technical), Akoka, Lagos state, Nigeria and Federal College of Education, Osiele, Abeokuta, Ogun state, Nigeria. To determine the mathematics ability of students, their first semester scores in a course titled "Algebra" (MAT 111) was used. The student background questionnaire was used to elicit information on age and gender of the respondents. The mathematics anxiety rating scale was originally designed and validated by Baloglu and Zelhart (2007). The scale has 14 items. The respondents were given instructions to rate their anxiety levels when faced with mathematical concepts. The questionnaire was designed using a four-point Likert-scale using the following response format: strongly agree (SA), agree (A), disagree (D) and strongly disagreed (SD). The reliability coefficient using Cronbach's alpha was found to be 0.82. The resulting data were analysed with the aid of Statistical Package for Social Sciences (SPSS) version 17.0 software using correlation and multiple regression.

RESULTS

The results and the relevant discussions are presented below in accordance with the hypotheses stated.

Hypothesis One: There is no significant difference in the achievements of male and female students in Algebra.

Table 1: T-test comparison of male and female students in Algebra

Gender	No	Mean	S.D	Tcal	Df	P-value	Remark
Male	82	55.06	18.583	0.372	158	0.711	N.S
Female	78	53.94	19.721				

Table 1 presents the t-test comparison of the scores of male and female students in Algebra. The t-test comparison showed a statistical difference which is not significant between the mean scores of male and female students in Algebra (tcalculated = 0.372, df = 158, $p > 0.05$). We therefore accept the null hypothesis. The mean scores showed a higher mean for male students. It therefore follows that the mean score of male students in Algebra (mean = 55.06, Standard deviation = 18.583) is higher but not significantly higher than that of their female counterparts (mean = 53.94, Standard deviation = 19.721).

Hypothesis Two: There is no significant difference in the achievements of students in Algebra across age groups.

Table 2: The Influence of Age on Achievement in Algebra.

	Sum of Squares	df	Mean Square	F	P-value
Between Groups	982.075	3	327.358	0.896	0.445
Within Groups	56987.900	156	365.307		
Total	57969.975	159			

The F value of 0.896 in Table 2 is not significant at 0.05 level of significance, implying that achievement in Algebra do not vary across age groups. On the sample selected however, the post hoc analysis showed that those between age 15 to 20 years had the highest mean score, while those above 30 years had the least mean score.

Hypothesis Three: There is no significant difference in the achievements of students in Algebra across mathematics anxiety groups.

Table 3: The Influence of mathematics anxiety on Achievement in Algebra.

	Sum of Squares	df	Mean Square	F	P-value
Between Groups	707.160	2	353.580	0.964	0.384
Within Groups	57206.023	156	366.705		
Total	57913.182	158			

The F value of 0.964 in table 3 is not significant at 0.05 level of significance, implying that achievement in Algebra do not vary across mathematics anxiety groups. On the sample selected however, the post hoc analysis showed that those that are in the medium anxiety level had the highest mean score, while the highest anxiety level had the least mean score.

DISCUSSION

The findings of this study agrees with the findings of Abiam and Odok(2006) , Habibollah, Abdullahi, Arizan, Sharir, and Kurma (2009) and Abubakar(2010). It is however in contrast with the findings of Epstein, Elwood, Hey, Maw (1998) and Hedges and Newell(1999). On the whole, it is hoped that if both gender are given proper

orientation, opportunities and training gender will no longer be an issue in mathematics achievement in general and achievement in Algebra in particular.

The insignificant differences in achievement in Algebra across age groups in this study agrees with Abubakar and Oguguo (2011), but disagrees with Walker, Greenwood, Hart & Carta, 1994), Crosses (1991) and La Paro & Pianta (2000). More influential factors might be active in determining variation in achievement in Algebra.

Level of anxiety was not seen to affect achievement in Algebra in this study. However among the participants of the study, those with medium level of anxiety performed best. This is in agreement with the assertion of Skemp (1986), that a moderate amount of anxiety may actually facilitate performance. Beyond a certain degree, anxiety hinders performance particularly in the case of higher mental activities and conceptual process.

CONCLUSION AND RECOMMENDATION

Gender, age and mathematics anxiety did not significantly affect achievement in Algebra. It is recommended that studies on the interaction effects of these variables should be carried out.

REFERENCES

- Abiam, P.O and Odok J.K (2006). Factors in students' achievement in different branches of secondary school mathematics. *Journal of Education and Technology* 1(1), 161-168
- Abubakar, R.B (2010). Qualitative and functional mathematics education, does age and gender affect academic performance? Proceedings of 47th Annual National Conference of mathematics association of Nigeria (MAN) held at nassarawa state Polytechnic, Lafia, Nigeria, 28th August – 3rd September, 2010 pp 210-215
- Abubakar R.B and Oguguo O.D (2011). Age and gender as predictors of Academic achievement of college mathematics and science students. Proceedings of the 2011 instructional conference on teaching, learning and change. Institution association for teaching and learning (IATEL)
- Ajayi, O.K and Muraina, K.O (2011). Parents' education, occupation and real mothers' age as predictors of students' achievement in mathematics in some selected schools in Ogun state, Nigeria. *Academic Online Journal*, 9(2)
- Akman Yesile D.B (2012). Test Anxiety in ELT Classes. *Frontiers of Language and Teaching*, 3, 24-31
- Ashcraft, M.H and Kirk, E.P (2001). The relationships among working memory, math anxiety and performance. *Journal of experimental psychology*, 130(2) pp 224-237
- Debaz, T. (1994). Meta-analysis of the relationship between students' characteristics and achievements and attitudes towards science. Columbus, OH:ERIC clearing house for science, mathematics and environmental education (ERIC Document 377079)
- Eccles T.S & Jacobs, J.E (1986). Social forces shape math attitudes and performance. *Signs: Journal of women in culture and society*, 11, 367-380
- Eniayeju, A.A (2010). Effects of cooperative learning strategy on the achievement of primary six boys and girls in mathematics. *ABACUS: The Journal of Mathematics Association of Nigeria* 35 (1), pp 1-9
- Epstein, D., Elwood, J., Hey, V. And Maw, J. (1998). Falling boys? Issues in gender and achievement. Buckingham: Open university press In Wong, K.C, Lan, Y.R and HO, L.M (2002). The effects of schooling on gender differences. *British educational research Journal*, 28, 827-843
- Frery, R.B and Ling, J.L (1983). A factor-analytic study of mathematics anxiety, education and psychological measurement, 43, 985-993
- Habibollah, N., Abdullahi, R., Arizan, H.T., Sharir, J. And Kurma, V.(2009). Creativity, age and gender in predictors of academic achievement among undergraduate students. *Journal of American Sciences* 5(5), 101-111

- Hedges, L. and Newell, A. (1990). Changes in Black-white gap in achievement scores. *Sociology of Education*, 72(2), 149-182
- Hembree R. (1990). The Nature, Effects and Relief of Mathematics Anxiety. *J. Research in Mathematics Education*, 21 (1) pp 33-46
- La Paro, K.M and Pianta, R.C (2000). Predicting children's competence in the early school years, A meta-analytic review, *Review of educational research*, 70 (4), pp 443-484.
- Larwin, K.H. (2010). Reading is fundamental in predicting math achievement in 10th Graders. *International Electronic Journal of mathematics Education – IEJME* 5(3)
- Owolabi, J. and Etuk-iren, O.A (2009). Gender, course of study and continuous and continuous assessment as determinants of students' performance in PRE-NCE mathematics, ABACUS: the *Journal of mathematics association of Nigeria*, 34(1), 106-111
- Quilter, D and Harper, E (1988). "Why we didn't like mathematics and why we can't do it". *Educational Research* 30, 121-134
- Rech, F.J and Stevens D.J (1996). Variables related to mathematics achievement among black students. *The journal of Educational Reseach* 89(6), pp 346-350
- Siegler, R.S., Duncan, G.J., Davis-Kean, P.E., DuckWorth, K., Claessens, A., Engel, M.T. and Chen, M. (2012). Early predictors of high school mathematics achievement. www.psy.cmu.edu/~siegler-et-al-inpresspsysci.pdf. Last accessed 25th October 2012. 1: 45pm
- Skemp, R.R (1986). *The Psychology of Learning Mathematics*. Hillsdale: Lawrence Erlbaum Associates.
- Walker, D., Greenwood, C., Hart, B., and Carta, J. (1994). Prediction of school outcomes based on early language production and socioeconomic factors. *Child Development* 65(2), pp 606-621.
- Wantananbe, L.E (2005). The effect of college students' employment on academic achievement. *University Of Central Florida Undergraduate Research Journal*, pp 38-47
- White, K (1982). The relation between socioeconomic status and academic achievement. *Psychological Bulletin*, 91, 461-481
- Wood E.F (1988). Math anxiety and elementary teachers: What does research tell us? *For the Learning of mathematics* 8 (1), pp 8-12
- Zhang, Y.X. (2004). A Study of the candidates' test anxiety in the CET-SET context. MA Dissertation, Chongqing University.

“I AM UN/SUCCESSFUL IN MATHEMATICS BECAUSE...” : STUDENTS’ SELF-PERCEIVED COMPETENCE IN MATHEMATICS

Hüseyin ÖZDEMİR

Neslihan ÖNDER ÖZDEMİR

The present study aims to investigate 76 students’ self-perceived competence in Mathematics in a state vocational high school in Turkey. The data was collected from five different classrooms through a reflective journal each student kept anonymously after taking Mathematics course. Students assessed themselves concerning their competence in Mathematics. Content analysis was employed to analyse the data. Findings revealed that 26 students reported that they were successful by providing 25 different reasons, while 45 students stated that they are unsuccessful with 21 different perceptions as salient themes. Five students felt both successful and unsuccessful in different aspects. The most frequent three salient explanations for successful students were ‘teacher’ ability to teach the course effectively, good background in Mathematics, the love for the course’. The most frequent three salient reasons for unsuccessful students were ‘insufficient background, not studying and difficulty in understanding Mathematics’. The reports of the students and pedagogical implications are provided in light of the literature.

Keywords: Mathematics, competence, success, unsuccess

BRAID FOLDING AND BURAU REPRESENTATION

Mohammed Mahyoub Ali AL-SHAMIRI

Mathematical Department, Faculty of Science, Ibb University, Ibb, Yemen.
Shamiri71@yahoo.com

ABSTRACT: In this article we introduce the definition of braid folding, and braid graph, the braid folding of braid is discussed, we prove that we can fold any braid graph by the graph folding, by using matrix Burau representation we describe the straight folding

Key words: Braid, braid group, braid folding, graph folding

INTRODUCTION

In 1925, Emil Artin, a mathematician born in Germany began a study that eventually developed into what is known as braid theory. This remarkable insight itself was not sufficient to sustain research in this area, and so it slowly began to wither. However, in the 1950s this concept of braids was found to have applications in other fields and this gave fresh impetus to the study of braids. By this braids theory has gradually been prospected, refined and polished, braid theory is, now recognized as one of the basic theories in mathematics and is of benefit in such branches as topology and algebraic geometry. The braid group was taken an important role in this field. In [6] and [7] we are studied a new direction on knot theory called folding of knots. The folding of manifold defined by Rebertson [16] and the folding of manifold into another, or into itself are studied by El-Kholy [8] and El-Ghoul [1-5]. In this article we introduce braid folding and braid graph and we describe the straight folding by using matrix Burau representation. Also we describe the graph folding of braid graph.

In this section we will summarize some definitions and basic concepts which we will use it in the main results.

Definition 2.1. Let D be a unit cube, so $D = \{(x, y, z) : 0 \leq x, y, z \leq 1\}$ on the top face of cube place n points, a_1, a_2, \dots, a_n and, similarly, place n points on the bottom face b_1, b_2, \dots, b_n . Now, join the points a_1, a_2, \dots, a_n with b_1, b_2, \dots, b_n by means of n arcs d_1, d_2, \dots, d_n (as smooth curves), these arcs are mutually disjoint and each d_i connects some a_j to b_k ($J \neq K$ or $J = K$) not connect a_j to a_k or b_j to b_k . Each plane E_s , such that $z = s$, $0 \leq s \leq 1$ (parallel to xy -plane) intersects each arc d_i at one and only one point.

A configuration of n arcs d_1, d_2, \dots, d_n with end points a_1, a_2, \dots, a_n and b_1, b_2, \dots, b_n is called n -braid or a braid with n strings Fig.(1)[13]

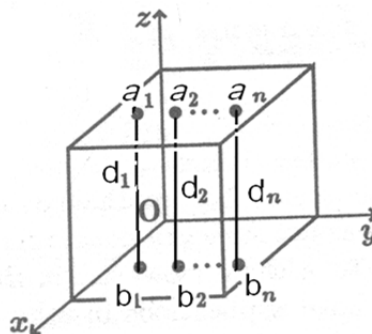

Fig.(1)

Definition 2.2. A map $F : M \rightarrow N$, where M, N are C^∞ Riemannian manifolds of dimension m, n , respectively, is said to be an isometric folding of M into N , if and only if for any geodesic path $\gamma : J \rightarrow M$ the induced path $F \circ \gamma : J \rightarrow N$ is a piecewise geodesic and of the same length as γ . If F does not preserve length, then F is a topological folding [16].

Definition 2.3. Let A be a subset of a topological space X . A continuous map $r : X \rightarrow A$ is said to be retraction if $r(a) = a$ for all $a \in A$ [12,14].

Definition 2.4. Let B_n be a set of all n -braids and $\beta_1, \beta_2 \in B_n$, we may create a third n -braid from them which we shall call their product and denoted by $\beta_1\beta_2$ as follows:

Glue the bottom arcs of β_1 with the top arcs of β_2 Fig.(2) [13].

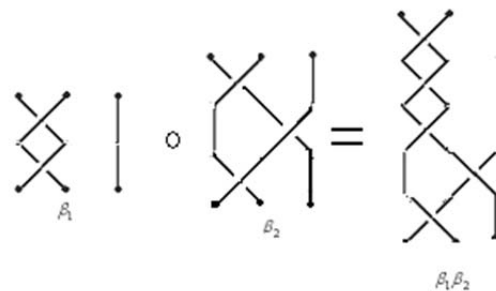

Fig.(2)

Remarks 2.1. 1) For $\beta_1 \in B_n$ there is $\beta_1^{-1} \in B_n$ such that $\beta_1\beta_1^{-1} = e \in B_n$ Fig.(3)

2) $\beta_1\beta_2 \neq \beta_2\beta_1$

3) The product of braids is associative, i.e. $(\beta_1\beta_2)\beta_3 \approx \beta_1(\beta_2\beta_3)$.

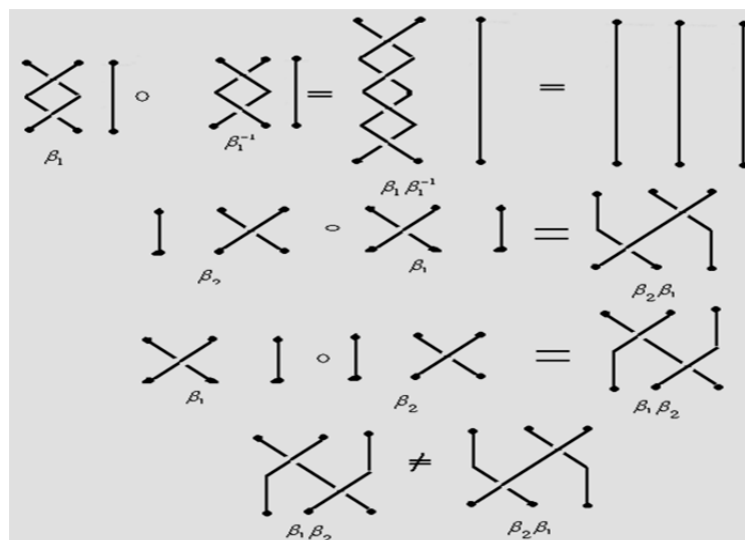

Fig.(3)

Theorem 2.1. The set of all n -braids B_n forms a group. This group is usually called the n -braid group or Artin's n -braid group [11, 13, 15].

Theorem2.2. For any $n \geq 1$ the n – braid group B_n has the following presentation,

$$B_n = \langle \sigma_1, \sigma_2, \dots, \sigma_{n-1} : \sigma_i \sigma_{i+1} \sigma_i = \sigma_{i+1} \sigma_i \sigma_{i+1} \text{ for } i = 1, 2, \dots, n-2 \\ \text{and } \sigma_i \sigma_j = \sigma_j \sigma_i \text{ for } |j-i| \geq 2 \rangle,$$

where σ_i denotes the standard generator of the braid group. Fig (4) [11, 13, 15].

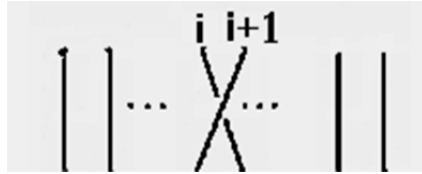

Fig.(4)

Definition 2.5. Let $\beta \in B_n$ be a n - braid define a mapping $\Phi_n : B_n \rightarrow M(n, \mathbb{Z}[t, t^{-1}])$ by

$$\Phi_n(\sigma_i) = \begin{bmatrix} I_{i-1} & & \\ \hline & 1-t & t \\ & 1 & 0 \\ \hline & & I_{n-i-1} \end{bmatrix}$$

where I_m is the $m \times m$ identity matrix and the empty matrix consisting of only zeros ,also

$$\Phi_n(\sigma_i^{-1}) = \begin{bmatrix} I_{i-1} & & \\ \hline & 0 & 1 \\ & t^{-1} & 1-t^{-1} \\ \hline & & I_{n-i-1} \end{bmatrix}$$

this representation of B_n is called the Burau representation[11,15].

Definition2.6. An n - dimensional manifold is a Hausdorff topological space M , such that every point of M has a neighborhood homeomorphic to open set $U \subset \mathbb{R}^n$ [14].

Definition2.7.A folding which folds a point of upper arc crossing on a point of lower crossing is said to be a crossing folding[6].

Definition2.8. A subset $A \subset X$ is a deformation retract of X if there is a retraction $r : X \rightarrow A$ such that $i \circ r$ homotopic to the identity map. That is, there exists a continuous function $f : X \times [0,1] \rightarrow X$ such that for $x \in X$, $f(x,0) = x$ and $f(x,1) = r(x)$ and for all $a \in A$ and all $t \in [0,1]$, $f(a,t) = a$ [14].

RESULTS AND FINDINGS

To obtain the main results ,we should introduce the following definitions.

Definition3.1. Let β, β' be two n-braids ,the map $f : \beta \rightarrow \beta'$ is said to be a braid folding, if $f(d_i) = d'_j$ where d_i is a string in β and d'_j is a string in β' , $i, j = 1,2,3,\dots,n, i = j$ or $i \neq j$.

If d_i and d'_j are straight strings ,then f is said to be straight folding.

Definition3.2. Let $A = [a_{ij}]$ be a matrix, the map $f : A \rightarrow A$ is said to be matrix folding, if f maps column to column or row to row .

Theorem3.1. A straight folding of a braid is a braid .

Proof. Let $\beta \in B_n$ be a n- braid with L straight strings and f be a straight folding from β into itself such that f folds m straight strings from L on themselves then $f(\beta)$ is $n-(m-1)$ - braid.

Corollary3.1. A limit of straight foldings of a braid into itself is a braid.

Proof. The proof comes directly from Theorem3.1.

Now we will give some conditions on the straight folding .

Theorem3.2. For every non-trivial n-braid $\beta, n \leq 3$,there is no non trivial straight foldings can be define for β .

Proof. Since β is non trivial, hence $n \neq 1$ if $n = 2$ then we can write $\beta = \sigma_1^m$ or $\beta = \sigma_1^{-m}$ And hence there is no straight strings can be folded it by straight folding.

If $n = 3$ then we can write:-

1) $\beta = \sigma_1^{\varepsilon m}$ or $\beta = \sigma_2^{\varepsilon m}$ $\varepsilon = \pm 1$ in this case there is only one straight strings and hence can not define straight foldings for β .

2) $\beta = \sigma_1^{\varepsilon m} \sigma_2^{\varepsilon l}$, $\varepsilon = \pm 1$ in this case there is no straight strings .

4.Braid folding and Burau representation

Let $\beta = \sigma_i$ be a n-braid and $\varphi_n(\sigma_i)$ its matrix Burau representation ,if f can be defined on β ,then we can be partition the matrix into four blocks, such that the matrix which appears in the upper left corner block or the matrix which appears in the lower right corner block is an identity matrix $I_m, m \geq 2$,and the matrix in the upper right corner block is a zero matrix.

Conversely, if the matrix Burau representation $\varphi_n(\sigma_i)$ can be partitioned into four blocks with the identity matrix $I_m, m \geq 2$ at the upper left corner or at the lower right corner and the zero matrix in the upper right corner block ,than a straight folding can be defined on β .

Examples.1) Let $\beta = \sigma_1$ be a 6-braid Fig.(5)



Fig.(5)

The matrix Burau representation $\varphi_6(\sigma_1)$ of β has the following form

$$\varphi_6(\sigma_1) = \begin{pmatrix} 1-t & t & 0 & 0 & 0 & 0 \\ 1 & 0 & 0 & 0 & 0 & 0 \\ 0 & 0 & 1 & 0 & 0 & 0 \\ 0 & 0 & 0 & 1 & 0 & 0 \\ 0 & 0 & 0 & 0 & 1 & 0 \\ 0 & 0 & 0 & 0 & 0 & 1 \end{pmatrix}$$

Now ,we can partition $\varphi_6(\sigma_1)$ to take the following form

$$\varphi_6(\sigma_1) = \left(\begin{array}{ccc|ccc} 1-t & t & 0 & 0 & 0 & 0 \\ 1 & 0 & 0 & 0 & 0 & 0 \\ 0 & 0 & 1 & 0 & 0 & 0 \\ \hline 0 & 0 & 0 & 1 & 0 & 0 \\ 0 & 0 & 0 & 0 & 1 & 0 \\ 0 & 0 & 0 & 0 & 0 & 1 \end{array} \right)$$

Thus we can define a straight folding $f_1 : \beta \rightarrow \beta$ by $f_1(d_6) = d_5$ Fig.(6).

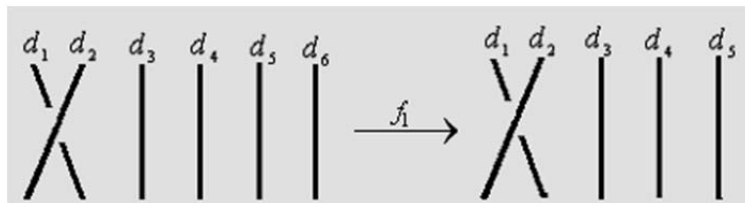

Fig.(6)

The matrix Burau representation $\varphi_6(f_1(\sigma_1))$ has the following form

$$\varphi_6(f_1(\sigma_1)) = \begin{pmatrix} 1-t & t & 0 & 0 & 0 \\ 1 & 0 & 0 & 0 & 0 \\ 0 & 0 & 1 & 0 & 0 \\ 0 & 0 & 0 & 1 & 0 \\ 0 & 0 & 0 & 0 & 1 \end{pmatrix} = \varphi_5(\sigma_1)$$

If we applying the matrix folding f from $\varphi_6(\sigma_1)$ into itself by folded the six column onto five column, then we have $\Phi_5(\sigma_1)$:

$$\begin{pmatrix} 1-t & t & 0 & 0 & 0 & 0 \\ 1 & 0 & 0 & 0 & 0 & 0 \\ 0 & 0 & 1 & 0 & 0 & 0 \\ 0 & 0 & 0 & 1 & 0 & 0 \\ 0 & 0 & 0 & 0 & 1 & 0 \\ 0 & 0 & 0 & 0 & 0 & 1 \end{pmatrix} \xrightarrow{f} \begin{pmatrix} 1-t & t & 0 & 0 & 0 \\ 1 & 0 & 0 & 0 & 0 \\ 0 & 0 & 1 & 0 & 0 \\ 0 & 0 & 0 & 1 & 0 \\ 0 & 0 & 0 & 0 & 1 \\ 0 & 0 & 0 & 0 & 0 \end{pmatrix} \simeq \begin{pmatrix} 1-t & t & 0 & 0 & 0 \\ 1 & 0 & 0 & 0 & 0 \\ 0 & 0 & 1 & 0 & 0 \\ 0 & 0 & 0 & 1 & 0 \\ 0 & 0 & 0 & 0 & 1 \end{pmatrix}$$

$\varphi_6(\sigma_1)$ $\varphi_5(\sigma_1)$

The result of matrix folding compatibles with the result of straight folding .

Note that we can also define a straight folding f_2 from $f_1(\beta)$ into itself Fig.(7), and we can also partition the matrix Burau representation $\varphi_6(f_1(\sigma_1))$.

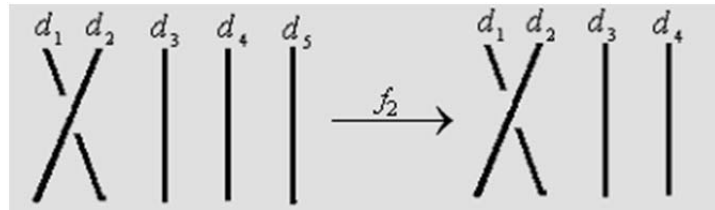

Fig.(7)

$$f_2(d_5) = d_4$$

$$\varphi_5(\sigma_1) = \varphi_6(f_1(\sigma_1)) = \left(\begin{array}{ccc|cc} 1-t & t & 0 & 0 & 0 \\ 1 & 0 & 0 & 0 & 0 \\ 0 & 0 & 1 & 0 & 0 \\ \hline 0 & 0 & 0 & 1 & 0 \\ 0 & 0 & 0 & 0 & 1 \end{array} \right)$$

The matrix Burau representation $\varphi_5(f_2(\sigma_1))$ has the following form

$$\varphi_5(f_2(\sigma_1)) = \begin{pmatrix} 1-t & t & 0 & 0 \\ 1 & 0 & 0 & 0 \\ 0 & 0 & 1 & 0 \\ 0 & 0 & 0 & 1 \end{pmatrix} = \varphi_4(\sigma_1)$$

By matrix folding we have:

$$\begin{pmatrix} 1-t & t & 0 & 0 & 0 \\ 1 & 0 & 0 & 0 & 0 \\ 0 & 0 & 1 & 0 & 0 \\ 0 & 0 & 0 & 1 & 0 \\ 0 & 0 & 0 & 0 & 1 \end{pmatrix} \xrightarrow{f_2} \begin{pmatrix} 1-t & t & 0 & 0 \\ 1 & 0 & 0 & 0 \\ 0 & 0 & 1 & 0 \\ 0 & 0 & 0 & 1 \end{pmatrix} \simeq \begin{pmatrix} 1-t & t & 0 & 0 \\ 1 & 0 & 0 & 0 \\ 0 & 0 & 1 & 0 \\ 0 & 0 & 0 & 1 \end{pmatrix}$$

$\varphi_5(\sigma_1)$ $\varphi_4(\sigma_1)$

We get the same result.

Also we can again define a straight folding f_3 from $f_2(f_1(\beta))$ into itself Fig.(8), and we can also partition the matrix Burau representation $\varphi_5(f_2(\sigma_1))$.

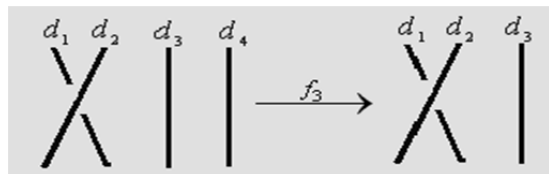

Fig.(8)

$$f_3(d_4) = d_3$$

$$\varphi_5(f_2(\sigma_1)) = \left(\begin{array}{cc|cc} 1-t & t & 0 & 0 \\ 1 & 0 & 0 & 0 \\ \hline 0 & 0 & 1 & 0 \\ 0 & 0 & 0 & 1 \end{array} \right)$$

The matrix Burau representation $\varphi_4(f_3(\sigma_1))$ has the following form

$$\varphi_4(f_3(\sigma_1)) = \left(\begin{array}{ccc} 1-t & t & 0 \\ 1 & 0 & 0 \\ 0 & 0 & 1 \end{array} \right) = \varphi_3(\sigma_1)$$

By matrix folding we have :

$$\left(\begin{array}{cccc} 1-t & t & 0 & 0 \\ 1 & 0 & 0 & 0 \\ 0 & 0 & 1 & 0 \\ 0 & 0 & 0 & 1 \end{array} \right) \xrightarrow{f_3} \left(\begin{array}{ccc} 1-t & t & 0 \\ 1 & 0 & 0 \\ 0 & 0 & 1 \end{array} \right) \simeq \left(\begin{array}{ccc} 1-t & t & 0 \\ 1 & 0 & 0 \\ 0 & 0 & 1 \end{array} \right)$$

$\varphi_4(\sigma_1)$ $\varphi_3(\sigma_1)$

It is the same result .Note that we can not define a straight folding and we can not partition the matrix Burau representation $\varphi_4(f_3(\sigma_1)) = \varphi_3(\sigma_1)$ and we can not apply the matrix folding on $\Phi_3(\sigma_1)$ this is exact the limit of matrix foldings also it is the limit of straight foldings.

2) Let $\beta = \sigma_5$ be a 6-braid Fig.(9).



Fig.(9)

$$\varphi_i(\sigma_i) = \begin{pmatrix} 1 & 0 & 0 & 0 & 0 & 0 \\ 0 & 1 & 0 & 0 & 0 & 0 \\ 0 & 0 & 1 & 0 & 0 & 0 \\ 0 & 0 & 0 & 1 & 0 & 0 \\ 0 & 0 & 0 & 0 & 1-t & t \\ 0 & 0 & 0 & 0 & t & 0 \end{pmatrix}$$

Similarly we can define a sequence of straight foldings $f_i : \beta \rightarrow \beta$ and The matrix Burau representation can be partitioned we get the limit as follows:

$$\varphi_i(\sigma_i) = \left(\begin{array}{ccc|ccc} 1 & 0 & 0 & 0 & 0 & 0 \\ 0 & 1 & 0 & 0 & 0 & 0 \\ 0 & 0 & 1 & 0 & 0 & 0 \\ \hline 0 & 0 & 0 & 1 & 0 & 0 \\ 0 & 0 & 0 & 0 & 1-t & t \\ 0 & 0 & 0 & 0 & t & 0 \end{array} \right) \xrightarrow{i \rightarrow \infty} \begin{pmatrix} 1 & 0 & 0 \\ 0 & 1-t & t \\ 0 & t & 0 \end{pmatrix} = \Phi_3(\sigma_2)$$

By matrix foldings we have:-

$$\begin{pmatrix} 1 & 0 & 0 & 0 & 0 & 0 \\ 0 & 1 & 0 & 0 & 0 & 0 \\ 0 & 0 & 1 & 0 & 0 & 0 \\ 0 & 0 & 0 & 1 & 0 & 0 \\ 0 & 0 & 0 & 0 & 1-t & t \\ 0 & 0 & 0 & 0 & t & 0 \end{pmatrix} \xrightarrow{f_1} \begin{pmatrix} 1 & 0 & 0 & 0 & 0 \\ 0 & 1 & 0 & 0 & 0 \\ 0 & 0 & 1 & 0 & 0 \\ 0 & 0 & 0 & 1-t & t \\ 0 & 0 & 0 & t & 0 \end{pmatrix}$$

$\Phi_6(\sigma_5) \qquad \qquad \qquad \Phi_5(\sigma_4)$

$$\xrightarrow{f_2} \begin{pmatrix} 1 & 0 & 0 & 0 \\ 0 & 1 & 0 & 0 \\ 0 & 0 & 1-t & t \\ 0 & 0 & t & 0 \end{pmatrix} \xrightarrow{f_3} \begin{pmatrix} 1 & 0 & 0 \\ 0 & 1-t & t \\ 0 & t & 0 \end{pmatrix}$$

$\Phi_4(\sigma_3) \qquad \qquad \qquad \Phi_3(\sigma_2)$

$\lim_{i \rightarrow \infty} f_i = f_3$. After $\Phi_3(\sigma_2)$ the matrix folding can not define

3) Let $\beta = \sigma_1 \sigma_2 \sigma_3$ be a 5-braid Fig.(10)

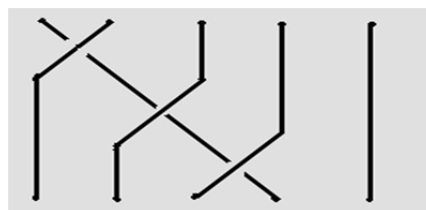

Fig.(10)

Its matrix Burau representation $\varphi_5(\sigma_1\sigma_2\sigma_3)$ is

$$\Phi_5(\sigma_1\sigma_2\sigma_3) = \begin{pmatrix} 1-t & t(1-t) & t^2(1-t) & t^3 & 0 \\ 1 & 0 & 0 & 0 & 0 \\ 0 & 1 & 0 & 0 & 0 \\ 0 & 0 & 1 & 0 & 0 \\ 0 & 0 & 0 & 0 & 1 \end{pmatrix}$$

We can not define a straight folding on $\beta = \sigma_1\sigma_2\sigma_3$ as a 5- braid ,also note that the matrix Burau representation $\varphi_5(\sigma_1\sigma_2\sigma_3)$ can not be partitioned and the matrix folding can not be defined.

After the above dissections we introduce the following theorem.

Theorem4.1. A straight folding f can be defined for β as n- braid if and only if the matrix Burau representation $\varphi_n(\beta)$ can be partitioned to four blocks, such that the matrix which appears in the upper left corner block or the matrix which appears in the lower right corner block is an identity matrix $I_m, m \geq 2$,and the matrix in the upper right corner block is a zero matrix.

Proof. Came directory from above discussion.

Corollary4.1. A straight folding f can be defined for β as n-braid if and only if the matrix folding \bar{f} can be defined for the matrix Burau representation $\varphi_n(\beta)$.

Theorem4.2. If f is a straight folding defines for $\beta = \sigma_1\sigma_2\dots\sigma_m$, then induces a straight folding \bar{f} on $\sigma_1, \sigma_2, \dots, \sigma_m$.

Proof. Since f was defined for $\beta = \sigma_1\sigma_2\dots\sigma_m$, this means $m < n - 2$ and hence $\forall \sigma_i, i < n - 2$ there is at least two straight strings can be folded, hence there is straight folding \bar{f} can be defined for all $\sigma_i, i = 1, 2, 3, \dots, m$.

Corollary4.2. The converse of theorem 4.2 is not necessary true.

Example 3 shows that.

5.Graph folding and Braid graph

If β is a braid we shall say that $\hat{P}(\beta) = \hat{\beta}$ is the projection of β Fig.(11).

\hat{P} The map that projects the point $\hat{P}(x, y, z)$ in E^3 onto the point $\hat{P}(x, y, 0)$. The effect of \hat{P} on β is to display a set of n simple curve d_1, d_2, \dots, d_n in E^3 on the xy – plane. In all probability ,a general projection onto the xy – plane will give a set of curves \hat{d}_i with many point of intersection of $\hat{\beta}$ However. In fact $\hat{\beta}$ is a graph represents β and has some properties:-

- 1- $\hat{\beta}$ has at most a finite number of points of intersection.
- 2- If Q is a point of intersection of $\hat{\beta}$ then $P^{-1}(Q) \cap \beta$ in β has exactly two points, which make a cross in β .
- 3- A vertex of β is never mapped onto a double point of $\hat{\beta}$.

A projection $\hat{\beta}$ that satisfies the above three conditions is said to be regular projection of β . By another mean $\hat{\beta}$ is a braid graph of β .

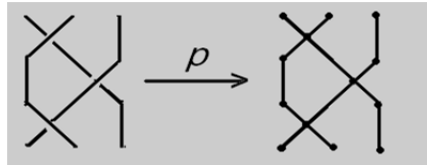

Fig.(11)

Let G_1 and G_2 be graphs and $f : G_1 \rightarrow G_2$ be a continuous function .Then f is called a graph map, if

- i) for each vertex $v \in V(G_1)$, $f(v)$ is a vertex in $V(G_2)$.
- ii) For each edge $e \in E(G_1)$, $\dim(f(e)) \leq \dim(e)$.

We call a graph map $f : G_1 \rightarrow G_2$ a graph folding if and only if f maps vertices to vertices and edges to edges ,i.e., for each $v \in V(G_1)$, $f(v) \in V(G_2)$ and for each $e \in E(G_1)$, $f(e) \in E(G_2)$. Else that, we can not get a graph folding [9].

In Fig. (15) δ_i is called δ_i - braid graph ,we make a braid graph of n-vertex in top level by δ_i , $i = 1,2,3,\dots, n-1$ and called it a n-braid graph



Fig.(12)

Note that δ_i in n – braid graph, $n > 2$ is a disconnected graph. Every n- braid graph which formed by $\delta_1, \delta_2, \dots, \delta_{n-1}$ together is a connected graph.

We consider BG the set of all n- braid graphs which have n- vertex in its top level and define the operation product on BG similar to the product in braid group therefore BG forms a monoid .This monoid generated by $\delta_1, \delta_2, \dots, \delta_{n-1}$. If β_i and $\beta_j \in BG$ then $\beta_i \beta_j \in BG$,also $\beta_i (\beta_j \beta_k) = (\beta_i \beta_j) \beta_k$,we consider $\hat{p}(\sigma_i \sigma_{i+1} \sigma_i) = \hat{p}(\sigma_{i+1} \sigma_i \sigma_{i+1})$, $i=1,2,3,\dots,n-1$ and $\hat{p}(\sigma_i \sigma_j) = \hat{p}(\sigma_j \sigma_i)$, $|i - j| \geq 2$

Theorem5.1. For every straight folding f of β into itself, β is a n-braid, there is an induced graph folding \bar{f} of $\hat{\beta}$ into itself, $\hat{\beta}$ is a n-braid graph.

Proof. Let f be a straight folding from β into itself, then $f(\beta)$ is a $(n-m)$ -braid, $m < n-2$, a projection of β , $\hat{\beta}$ is a n -braid graph, hence there is a graph folding \bar{f} from $\hat{\beta}$ into itself such that $\bar{f}(\hat{\beta})$ is a $(n-m)$ -braid graph which exact $\bar{p}(f(\beta))$.

Theorem 5.2. Every connected braid graph $\beta = \delta_1 \delta_2 \delta_3 \dots \delta_{n-1}$ can be folded into itself by a sequence of graph foldings onto an edge.

Proof. Let $\beta = \delta_1 \delta_2 \delta_3 \dots \delta_{n-1}$ Fig.(13) be a braid graph of n -vertex in its top level. Then the vertices set of β is $V(\beta) = \{v_1, v_2, v_3, \dots, v_m\}$, $m > n$, and the edge set of β is $E(\beta) = \{e_1, e_2, e_3, \dots, e_{m-1}\}$.

Let $f_1 : \beta \rightarrow \beta$ be a graph folding, where $f_1(\beta) = \beta_1$ is a subgraph of β by fold one edge or more, and $f_2 : \beta_1 \rightarrow \beta_1$, where $f_2(\beta_1) = \beta_2$ is a subgraph of β_1 also by fold one edge or more, until we get one edge.

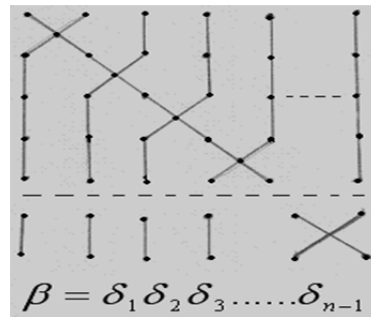
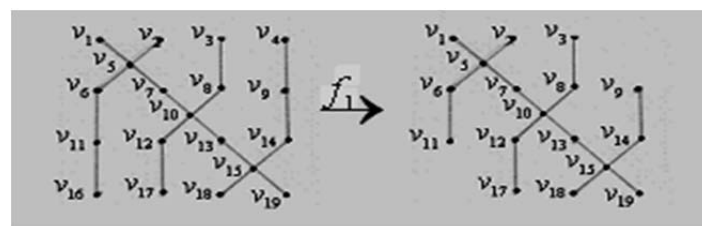

Fig.(13)

Corollary 5.1. Every braid graph $\beta = \delta_{n-1} \delta_{n-2} \dots \delta_2 \delta_1$ can be folded into itself by a sequence of graph folding onto an edge.

Proof. Similar to the proof of theorem (5.2).

Example 5.1. Let $\beta = \delta_1 \delta_2 \delta_3$ be a 4-braid graph, its vertex set $V(\beta) = \{v_1, v_2, \dots, v_{19}\}$ Fig.(14). Let $f_1 : \beta \rightarrow \beta$ be a graph folding defined as follows. $f_1 \{v_4, v_{16}\} = \{v_{14}, v_6\}$ and $f_1 \{e = \{v_{11}, v_{16}\}, e = \{v_4, v_9\}\} = \{e = \{v_{11}, v_6\}, e = \{v_9, v_{14}\}\}$ a graph $f_1(\beta) = \beta_2$ can be folded again as follows. Let $f_2 : \beta_1 \rightarrow \beta_1$ be given by $f_2 \{v_3, v_9, v_{11}, v_{17}\} = \{v_{10}, v_{15}, v_5, v_{10}\}$ and $f_2 : \{e = \{v_3, v_8\}, e = \{v_{11}, v_6\}, e = \{v_9, v_{14}\}, e = \{v_{17}, v_{12}\}\} = \{e = \{v_8, v_{10}\}, e = \{v_{11}, v_6\}, e = \{v_{14}, v_{15}\}, e = \{v_{12}, v_{10}\}\}$ also, again $f_2(\beta_2)$ can be folded until we get a graph consists of only one edge Fig.(14).



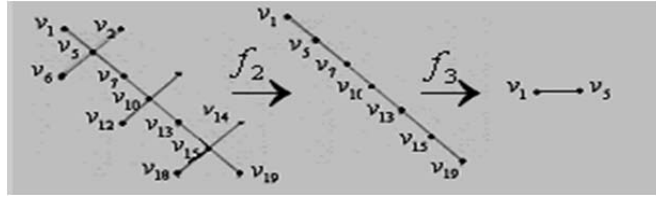

Fig.(14)

Theorem 5.3. Let A_n be a monoid braid graph generated by a_1, a_2, \dots, a_{n-1} , where $a_i = \delta_{n-1} \delta_{n-2} \dots \delta_{i+1} \delta_i^2 \delta_{i+1} \delta_{i+2} \dots \delta_{n-1}$, then we can fold any connected element in A_n into itself by sequence of graph foldings onto an edge.

Proof . Let b an element in A_n , then $b = a_i$ or $b = a_1 a_2 \dots a_m$, if $b = a_i$ then we can define a graph folding $f : a_i \rightarrow a_i$ by $f(a_i) = a'_i$ where $a'_i = \delta_1 \delta_2 \dots \delta_{n-1}$ and by theorem(5.1) we can define a sequence graph folding on a'_i until we get a graph consists of only one edge.

If $b = a_1 a_2 \dots a_m$ then we can define a graph folding $g : b \rightarrow b$ by $g(a_1 a_2 \dots a_m) = (a'_1 a_2 \dots a'_m)$ where $a'_1 = \delta_1 \delta_2 \dots \delta_{n-1}$ and $a'_m = \delta_{n-1} \delta_{n-2} \dots \delta_m$ hence

$a'_1 a_2 \dots a'_m = \delta_1 \delta_2 \dots \delta_{n-1} \delta_{n-1} \dots \delta_3 \delta_2^2 \delta_3 \dots \delta_{n-1} \delta_{n-1} \dots \delta_4 \delta_3^2 \delta_4 \dots \delta_{n-1} \delta_{n-1} \dots \delta_m$ every $\delta_j \delta_j$ can be folded onto two edges connect between two intersection points of first δ_j and second $\delta_j \forall j$, continue this way until we get a graph consists of only one edge .

Example5.2. Let A_4 be a monoid braid graph generated by $a_1 = \delta_3 \delta_2 \delta_1^2 \delta_2 \delta_3$, $a_2 = \delta_3 \delta_2^2 \delta_3$, $a_3 = \delta_3^4$ Fig.(15), we take $b_1 = a_1 a_2 = \delta_3 \delta_2 \delta_1^2 \delta_2 \delta_3 \delta_3 \delta_2^2 \delta_3$, $b_2 = a_1 a_3 = \delta_3 \delta_2 \delta_1^2 \delta_2 \delta_3 \delta_3^4$ and applying a graph folding on b_1 and b_2 see Fig.(16) and Fig.(17).

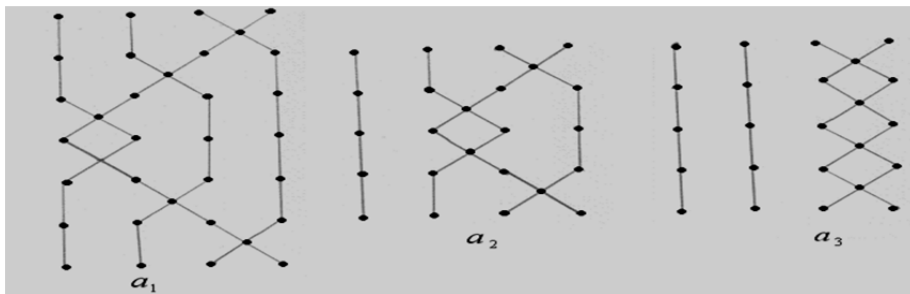
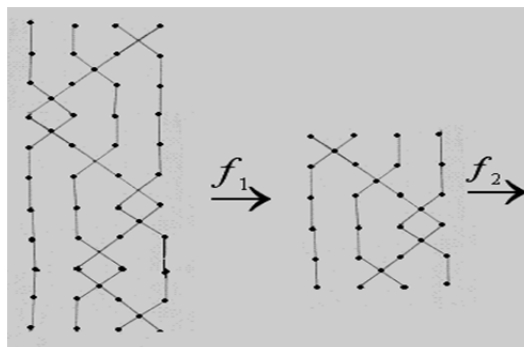

Fig.(15)



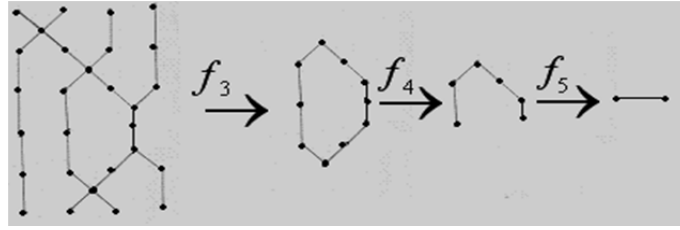

Fig.(16)

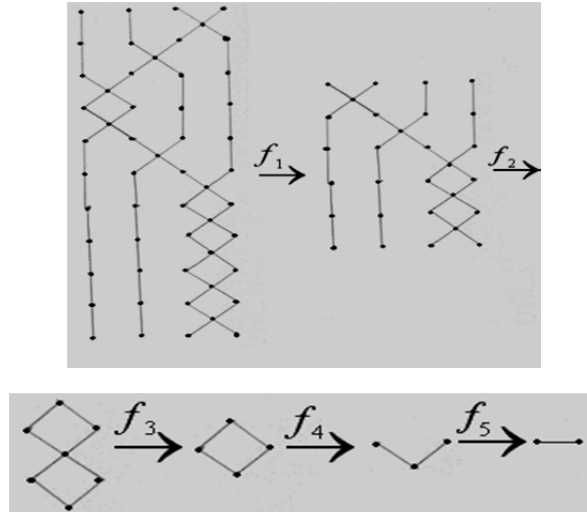

Fig.(17)

After we introduce a braid graph and apply the graph folding on it .Is all braid graph can be folded by a graph folding? and what the result?.To answer we introduce the following theorem

Theorem5.4. Let $\beta = (\delta_1 \delta_2 \delta_3 \dots \delta_{n-1})^{n-1}$ be a n-braid graph ,then we can be folded β into itself by sequence of graph foldings onto a complete graph K_3 .

Proof. The proof came directly from the above discussion.

Example5.3. Let $\beta = (\delta_1 \delta_2 \delta_3)^3$ be a4- braid graph then we can make the following graph folding and get a complete graph K_3 .Fig.(18) .

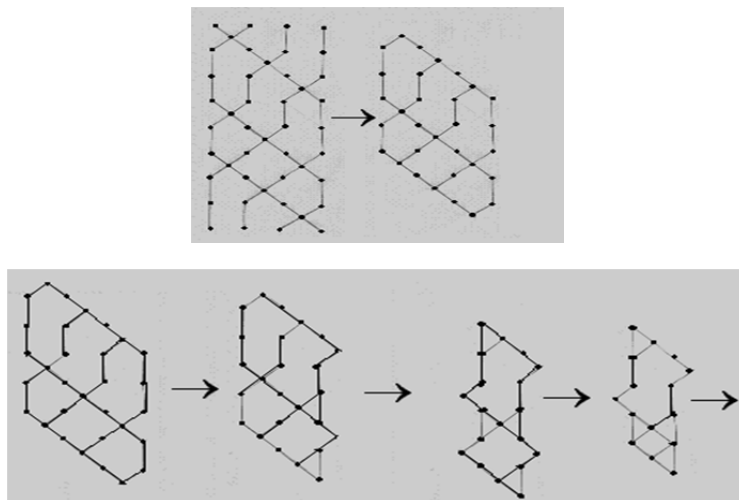

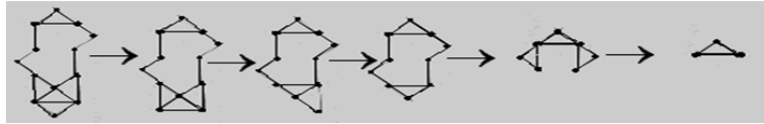

Fig.(18)

Theorem5.5. Any connected braid graph can be folded into itself by a sequence of graph foldings onto an edge or complete graph K_3 .

Proof. The proof came directory from the above theorems.

REFERENCES

- [1] M. El-Ghoul, The deformation retraction and topological folding of manifold ,comm..Fac.Sic. Univ. Ankara series Av.37-pp(1998) (1-7).
- [2] M .El-Ghoul, The deformation retract of complex projective and its topological folding , Journal of material science (30), England (1995) 4145-4148.
- [3] M. El-Ghoul, Folding of manifolds, Ph.D. Thesis Univ. Tanta. Egypt ,(1985).
- [4] M. El-Ghoul & H.I. Attiya, The Dynamical Fuzzy topological space and its folding the Journal of Fuzzy mathematics Vol.12 ,No.3, 2004.
- [5] M. El-Ghoul, Fractionl folding of manifold.Chaos,Soliton Fract., England;12 (2002) 1019 -1023.
- [6] M. El-Ghoul, A.I.Elrokh & M. M .Al-Shamiri, Folding of trefoil knot and its graph,Journal of Mathematics and Statistics2(2)368-372,2006.
- [7] M. El-Ghoul, A.I.Elrokh & M. M .Al-Shamiri, Folding of tubular trefoil knot,International Journal of applied Mathematics,(acceptance)
- [8] El-Kholy E.Isometric and topological folding of manifolds. Ph.D Thises, University of Souththampton,UK,1977.
- [9] El-Kholy and A.El-Esawy,Graph Folding of Some Special Graphs, Journal of Mathematics and Statistics1 (1) 66-70,2005
- [10] A. I. Elrokh, Graphs,Knots and Links, Ph.D. Thesis. Univ.Ernst- Moritz-Arndt Greifswad.(2004).
- [11] Gemein. B, Representations of the singular braid monoid and group invariants of singular knots, Topology and its applications 114 (2001)117-140.
- [12] W.S.Massay,Algebraic Topology.An Introduction, Harcout,Brace and World, New York ,1967.
- [13] Kunio Murasugi and Bohdan I. Kurpita, A Study of Braids, Kluwer Academic pub. London ,1999.
- [14] J.R. Munkers, Topology,A First Course, Prentice –Hall Inc., Englewood Cliffs ,New Jersey,U.S.A,(1975).
- [15] K .Murasugi ,Knot Theory and its Applications , Birkhaser, Boston, MA , 1996.
- [16] S.A.Robertson, Isometric folding of Riemannian manifold,ProcRoy Soc. Edinburgh 77(1977) 275-284.

AN ASSESSMENT TOWARDS THE PUBLICATINONS OF UNESCO ABOUT MATHEMATICS EDUCATION (1989-2013)

Hakan YAMAN
AIBU Education Faculty
hakanyaman@ibu.edu.tr

Sefa DÜNDAR
AIBU Education Faculty
sefadundar@ibu.edu.tr

Ülkü AYVAZ
AIBU Education Faculty
ulku.yesilyurt@ibu.edu.tr

ABSTRACT:The word “UNESCO” was created by being taken the initials of “United Nations Educational, Scientific and Cultural Organization” (Altun & Ata, 2013). UNESCO has undertaken two main objectives as it can be understood from the name of the organization. This organization is an international organization that works for the expedience of the world in long term and as a whole aims to serve to the aims of United Nations including humanitarian purposes. Moreover, the organization aims to support and develop all aspects of the concepts of education, science and culture (Huxley, 1946: 4). Based on these purposes, UNESCO has provided the preparation of many publications as book, journal, report, and article etc. in the field of education. It is seen that some of these publications are related with mathematics education.

The aim of this study is to examine the publications of mathematics education published by UNESCO from “Standards and Principles for School Mathematics” document of NCTM issued in 1989 to present. These publications are comprised of article, book, report and documents placed in the publications of education in the web site of the organization. 272 publications of UNESCO were examined with document analysis. In the study, document analysis method, one of qualitative research methods, was used. Investigated publications were analyzed in terms of publication years, publication types, subject areas, contents and related countries. Descriptive analysis method was used in the process of analysis of publications. As the result of investigation of these publications of UNESCO about mathematics education, it is revealed that the publications focused especially on mathematics education programs of countries, international measurement and assessment exams as TIMMS, PISA and subjects about teaching and learning mathematics.

Key words: UNESCO, mathematics education, NCTM

INTRODUCTION

The word “UNESCO” was created by being taken the initials of “United Nations Educational, Scientific and Cultural Organization” (Altun & Ata, 2013). The aim of UNESCO, as it is understood from the name of the organization, can be summarized as contributing to global peace, removing poverty, sustainable development and inter-communal dialogue based on shared common values. There are 195 full members and 9 associated members of UNESCO in the world. It is possible to reach the list of the member countries and the date of their membership on the website of the organization.

It has been one of the main aims of the organization to encourage tolerance and peace since the establishment of the organization. The main approach of the organization is educational: the action program is quite extensive and variable including not only international explanation of tolerance and peace concepts but also development of textbooks, production of education materials, organizations of seminar and conference and initiation of “The Associated School Project” (UNESCO, 1997:40). Education is one of the primary areas of UNESCO. UNESCO believing that education is the key point in social and economic development and undertaking a humanitarian educational vision, has been studying to improve education worldwide since its establishment (www.unesco.org). For example, the organization has carried out its educational activities within the framework of program accepted in World Education Forum in DAKAR in 2000 and determining the goals to be achieved up to 2005 which is called shortly as “Education for All”. UNESCO substantially comes into prominence with studies and agreements setting standards that the organization pioneers in the international field.

In this study, it was attempted to explain the general situation of the studies of UNESCO about mathematics education from 1989 to today. The aim of the study is to evaluate these studies of UNESCO in terms of the questions below. The research questions are as follows:

1. How is the distribution of the publications of UNESCO about mathematics education according to years?
2. How is the distribution of the publications of UNESCO about mathematics education according to publication series?
3. How is the distribution of the publications of UNESCO about mathematics education according to continents and countries?
4. How is the distribution of the publications of UNESCO about mathematics education according to whether the publications are UNESCO publication or not?
5. How is the distribution of the publications of UNESCO about mathematics education according to subject areas?
6. How is the distribution of the publications of UNESCO about mathematics education according to accessibility (online access)?

METHOD

Research Design

In this study, aiming to examine the publications of UNESCO about mathematics education, descriptive model was used because of the fact that it was aimed to describe the existing situation as it is. Qualitative research method was used in collection, analysis and evaluation of obtained data.

The Investigated Publications

1198 publication were obtained in the expert search section of data base of UNESDOC. Because of the difficulty of examination of 1198 publications obtained by purposive sampling method, 272 of these publications whose publication language was English and which were published after the publication of the “Principles and Standards for School Mathematics” document of NCTM, were examined in the scope of this study.

Data Collection

Document analysis method was used as data collection technique in the study. Document analysis includes analysis of written materials giving information about case or cases aimed to investigate. Document analysis can be performed in five stages in general as: reaching documents, control of originality, analysis of data and use of data (Yıldırım& Şimşek, 2011). In the study, the publications reached from UNESDOC data base were investigated in accordance with these stages.

UNESCO offers the publications that has been published and included in its libraries and on its data base to relevant people via four different web sources. These sources are “Online Book for Sale” section where book, multiple media, periodical and scientific maps for professionals in six languages (English, French, Spanish, Russian, Chinese and Arabic) are sold, “UNESDOC data base” section where approximately 120 000 publications in six languages published form 1945 to today are offered to online access freely, “UNESCO Library” in Paris and “archive” section at the same place. In this study, UNESDOC data base having online access was used and it was reached to this data base from the address of <http://www.unesco.org/new/en/unesco/resources/online-materials/publications/unesdoc-data base/>.

Data Analysis

Information about the publications as it is given in Figure 1 is seen when it is clicked on the link of the publications investigated as a result of searching on UNESDOC data base. On this webpage it is seen that title, publication series (if exists), country, publication date, key words, situation of online access and document type of the publications. Publication date, country, publication series, subject area, situation of being a UNESCO publication and online access were determined as the categories of the study.



Figure 1. An example publication tag from UNESDOC data base

FINDINGS

1. The Distribution of the Publications of UNESCO about Mathematics Education according to Years

It is found that although UNESCO was established in 1945, the publications about mathematics education on UNESCO website had started to be published in 1935. The reason for this is that this publication was on UNESCO data base although it was a non-UNESCO publication. Moreover, it is found that there were any publications published in 2014.

As it was stated in methodology, the examination was carried out between the years of 1989 and 2013 and for the distribution to be seen better, the numbers of publications were given in 3 groups of years, two of which contained 8 years and the one contained 9 years (See Table 1).

Table 1. The Distribution of the Publications about Mathematics Education on UNESCO Website according to Years

Years	Number	Percentage	Years	Number	Percentage	Years	Number	Percentage	Years
1989	8	2,94	1998	13	4,78	2006	25	9,19	
1990	11	4,04	1999	18	6,62	2007	15	5,51	
1991	7	2,57	2000	8	2,94	2008	14	5,15	
1992	25	9,19	2001	8	2,94	2009	9	3,31	
1993	11	4,04	2002	12	4,41	2010	12	4,41	
1994	4	1,47	2003	8	2,94	2011	6	2,21	
1995	10	3,68	2004	12	4,41	2012	6	2,21	
1996	10	3,68	2005	12	4,41	2013	1	0,37	
1997	7	2,57	Total	91	33,46	Total	88	32,35	
Total	93	34,19							

When the table is examined, it is seen that the most publications were published in 1992 (25 publications) in the group of the years between 1989 and 1997, in 1999 (18 publications) in the group of the years between 1998 and 2005 and in 2006 (25 publications) in the group of the years between 2006 and 2013.

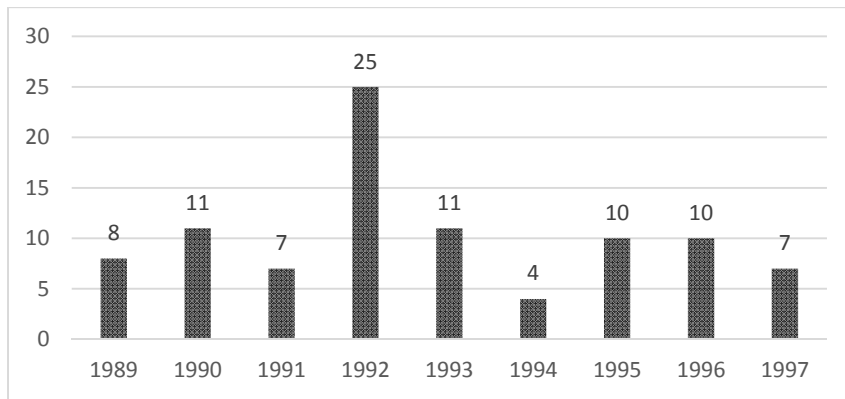

Graph 1. The Publications about Mathematics Education Published between the years of 1989 and 1997 and Placed on UNESCO Website

When the publications in 1992 were examined, it is appealed that 15 of 25 publications were published in “*Moving into the twenty-first century: (Studies in mathematics education)*” series and 13 of the publications were related to investigation of mathematics education systems of different countries. 4 of other 10 publications published in 1992 were related to mathematics education in countries. From this point of view, it can be stated that most of the publications were about the mathematics systems of the countries

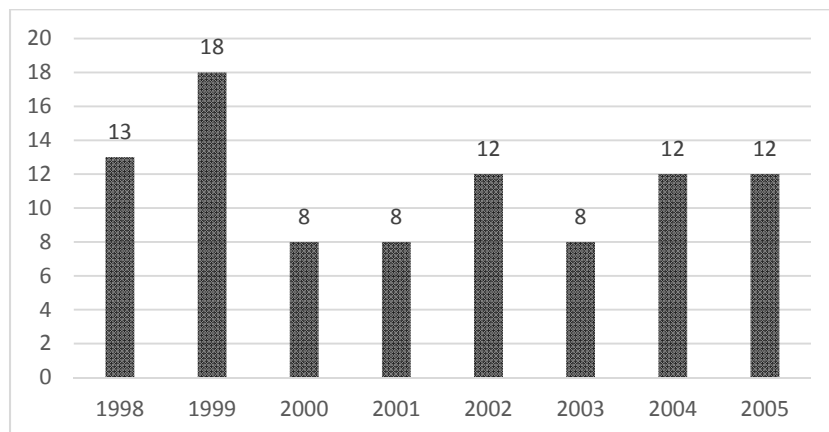

Graph 2. The Publications about Mathematics Education Published between the years of 1998 and 2005 and Placed on UNESCO Website

When the publications in 1999 were examined, it is seen that 13 of 18 publications were related to mathematics course education programs. 9 of these publications were about mathematics course education programs from 1st grade to 9th grade, separately. 3 of remaining 4 publications were about program comparisons and 1 of them was about program development.

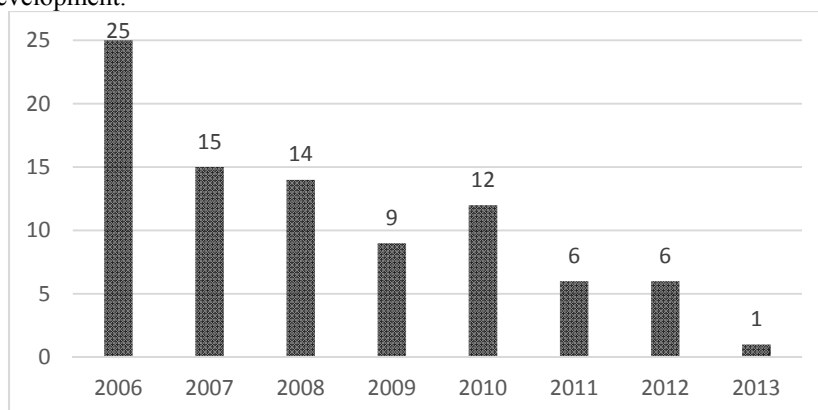

Graph 3. The Publications about Mathematics Education Published between the years of 2006 and 2013 and Placed on UNESCO Website

When the publications in 2006 were examined, it is seen that 22 of 25 publications were related to mathematics course education programs. Among the rest of the publications, 1 publication was about measurement-

assessment, 1 publication (for each) was about the use of technology and computer in mathematics education and the other was about counting.

2. The Distribution of the Publications of UNESCO about Mathematics Education according to Publication Series

When the publications were examined, it seen that 87 of 272 publications were classified in specific series. The distribution of the publications according to series were given in Graph 4.

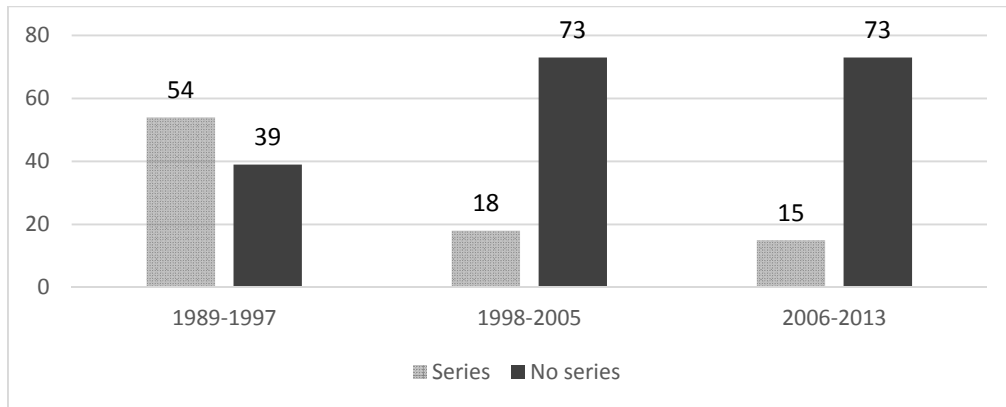

Graph 4. The Distributions of Publication Series of the Publications of UNESCO about Mathematics Education according to Years

When Graph 4 is examined, it is seen that the publications between the years of 1989 and 1997 were published in series mostly. It is appealed that the publications were not published in series mostly from past to present; they were published as independent publications.

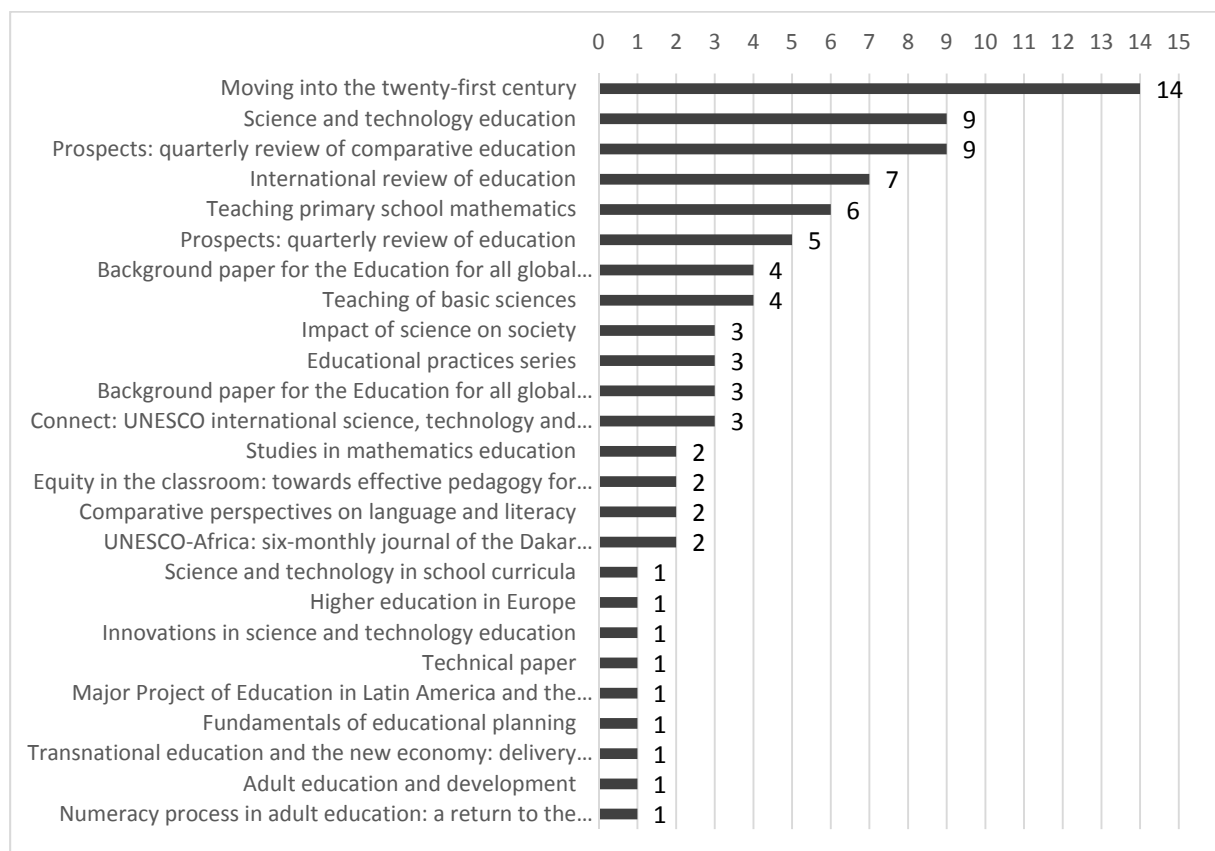

Graph 5. Publication Series of the Publications of UNESCO about Mathematics Education

When the publication series were examined, most of the publications were in "Moving into the twenty-first century" series with 14 publications. The series aims to examine mathematics education systems of countries while entering into 21st century. It was followed by "Science and technology education" and "Prospects: quarterly review of comparative education" series with 9 publications in each.

3. The Distribution of the Publications of UNESCO about Mathematics Education according to Continents and Countries

As the result of examination, it is seen that the publications about mathematics education on UNESCO website were published in countries of 5 continents (Africa, America, Europe, Asia, Oceania). The distributions of the publications according to the continents were given in Table 2.

Table 2. The Distributions of the Publications about Mathematics Education on UNESCO Website according to the Continents

Continent	Numbers of Countries in Continent *	Numbers of Countries about which Publications Published		Number of Publications	
		f	Percentage in terms of numbers of countries in continent	f	Number of Publications Per Year
Asia	49	17	34.69	37	2.18
Europe	43	14	32.55	70	5.00
America	41	14	34.14	66	4.71
Oceania	17	5	29.41	13	2.60
Africa	54	14	25.93	62	4.43

* In the table 204 members of UNESCO are given totally (195 countries are full members and 9 countries are associated members).

When Table 2 was examined, it is seen that the continents where the number of the publications was the most between the years of 1989 and 2013 were Asia and America. However, when the numbers of countries in the continents were taken into consideration, it is appealed that publications about mathematics education existed in approximately 35 % of the countries in the continents of Asia and America. Africa was the continent having the least value for this ratio.

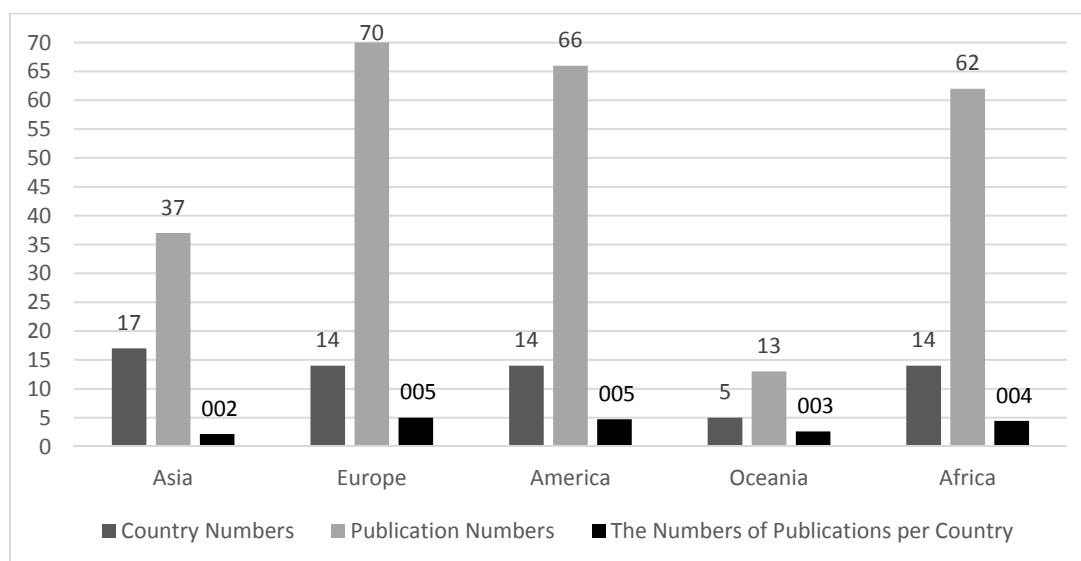

Graph 6. The Graph of the Publications about Mathematics Education Published between the years of 1989 and 2013 and Placed on UNESCO Website according to the Continents of Related Countries

When Graph 6 was examined, it is seen that Europe was the continent that the number of publications per country was the most with 5 publications and Asia was the continent that the numbers of publications per country was the least with 2,18 publications. Because of the fact that 37 publications were published for 17 countries in the continent of Asia, the number of publications per country was less. Moreover, the numbers of publications published in the countries placed in these continents were given in Table 3.

Table 3. The Distributions of the Publications about Mathematics Education on UNESCO Website according to the Countries

Country	Number	Country	Number	Country	Number
No information	24	Belize	3	Argentina	1
French	19	Botswana	3	Bhutan	1
UK	16	Philippines	3	Bulgaria	1
USA.	13	Indonesia	3	Cook Islands	1
Antigua and Barbuda	10	Canada	3	Denmark	1
Bahamas	9	Hungary	3	Philippines	1
South Africa	9	Mauritius	3	Developing countries	1
Australia	8	Senegal	3	Iran	1
Jamaica	8	Trinidad and Tobago	3	Cairo	1
Namibia	8	Uganda	3	Qatar	1
Swiss	7	Zambia	3	Kuwait	1
Thailand	7	Zimbabwe	3	Lesotho	1
Africa Countries*	6	Caiman Islands	2	Malaysia	1
Germany	6	Dominic Republic	2	Malta	1
Kenya	6	Estonia	2	Holland	1
Rwanda	5	Iraq	2	Nigeria	1
Brazil	4	Italy	2	Norway	1
Chili	4	Japan	2	Palau	1
Ghana	4	Egypt	2	Paris	1
India	4	Nepal	2	Romania	1
Sweden	4	Samoa	2	Sri Lanka	1
OECD	4	Singapore	2	Uruguay	1
Pakistan	4	Arabia Countries *	1	Victoria	1
America Countries *	3			Total:	272

* Presented as this because of being titled generally and not being stated any specific country.

When Table 3 was examined, it is seen that 24 publications did not have information about country. It is also appealed that 19, 16 and 13 of the publications were published in France, the United Kingdom and the United States of America, respectively. This finding shows that there were more publications in three of the biggest countries in the world. Moreover, it is quite meaningful that the numbers of the publications were the most in France when it is thought that the central office of UNESCO is in France (<http://en.unesco.org/feedback/contact-us>)

4. The Distribution of the Publications of UNESCO about Mathematics Education according to whether the Publications are UNESCO Publication or not?

It is seen that the publications about mathematics education were presented under two categories as: UNESCO publication and non-UNESCO publication. The distributions of the publications according to this criteria was given in Graph 7. For these publications to be seen better in terms of years, they were presented in 3 groups of years.

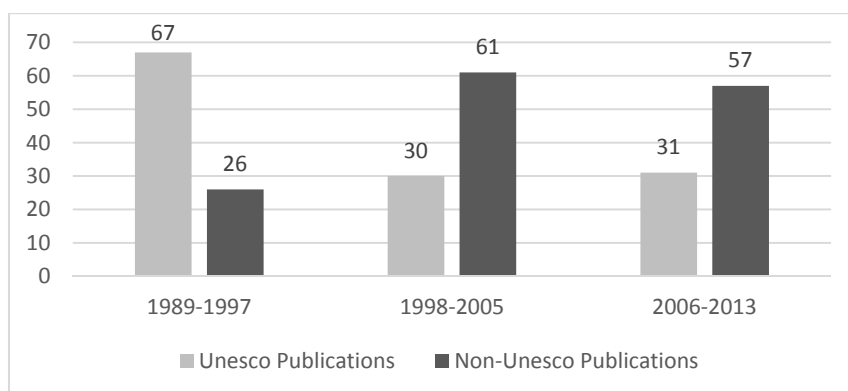

Graph 7. The Distribution of the Publications of UNESCO according to UNESCO and Non-UNESCO Publications

When Graph 7 was examined, it is seen that the numbers of UNESCO publications were the most between the years of 1989 and 1997 with 67 publications and there were nearly 30 publications in other groups of years. Moreover, it is found that the numbers of UNESCO publications have decreased since 1988.

5. The Distribution of the Publications of UNESCO about Mathematics Education according to Subject Areas

The publications of UNESCO published between the years of 1989 and 2013 were examined according to subject areas. When the publications were examined, they were coded according to the key words and contents of the publications. As a result of coding, five main themes were formed as education curriculum, general education cases, mathematics education, subject areas and no subject (See Table 4). The subjects of some of the publications could not be determined. Therefore, a theme as “no subject” was formed. The reason for not determining the subjects of some of the publications was that the publications did not have online access and the key words were insufficient to explain the contents of the publications.

Table 4. The Distributions of the Publications about Mathematics Education on UNESCO Website according to the Subject Areas

Categories	Pub. Numbers	Subjects	Pub. Numbers
Education Curriculum	86	Mathematics Curriculum	74
		Computer-Technology-Material	6
		Text Books	5
		Course Syllabus	1
General Education Cases	63	Countries and country comparatives	34
		Teacher Education	12
		Learning Class, Disabilities of Mathematics, Culture and Problems and Solving Suggestions	6
		Equity and Gender Differences	4
		Conference	3
		Special Education	2
		Higher Education	1
		Olympics	1
		Gifted and Talented Students	1
		Mathematics Education	89
Evaluation and Assessment (PISA, TIMMS)	25		
Teaching of Mathematics	15		
Learning of Mathematics	8		
Mathematics Education in Future	1		
History of Mathematics Education	2		
Subject Areas	16	Number and Numerosity	8
		Statistic	3
		Fractions	2

	Teaching of Arithmetic	1
	Problem Solving	1
	Street and School Mathematics	1
None	17	

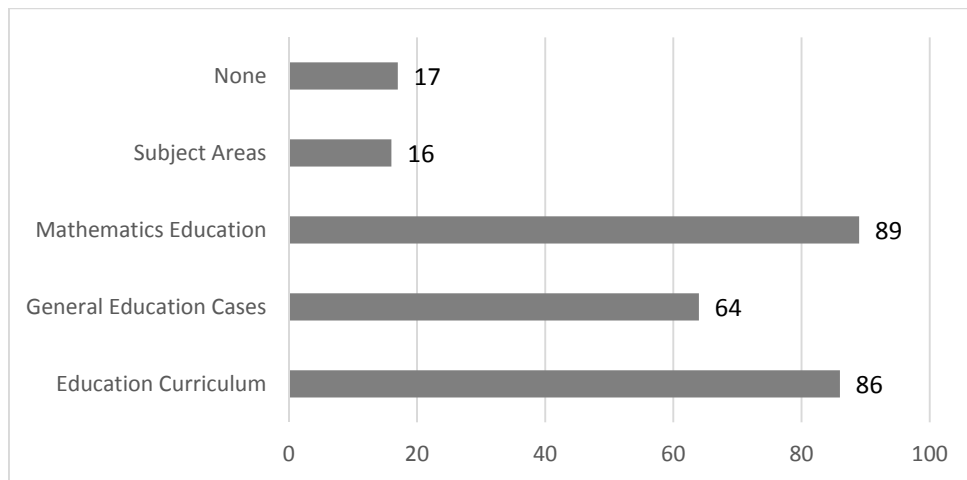

Graph 8. The Subjects of the Publications about Mathematics Education Published between the years of 1989 and 2013 and Placed on UNESCO Website according to the Subject Areas

It is seen in Graph 8 that 89 of the publications were about mathematics education. This theme was followed by education programs with 86 publications, general education cases with 64 publications and subject areas including sub-areas of mathematics with 16 publications. The subjects of the publications published between the years of 1989-2013 were not determined.

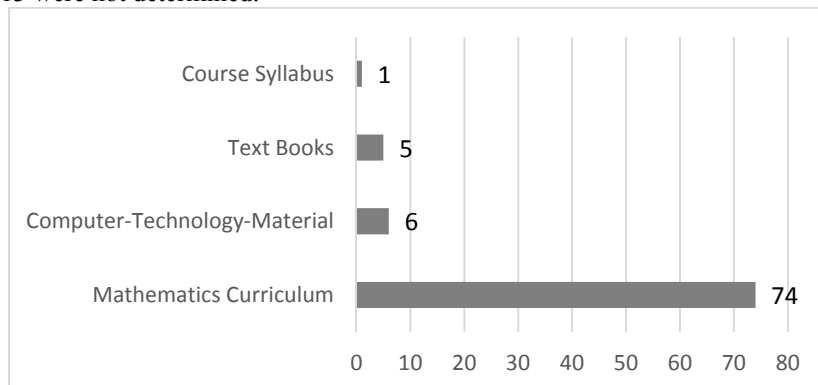

Graph 9. The Publications about Education Programs

The most of the publications in the theme of education programs were about mathematics course education programs. It is also seen that there were not many publications about textbooks (See Graph 9).

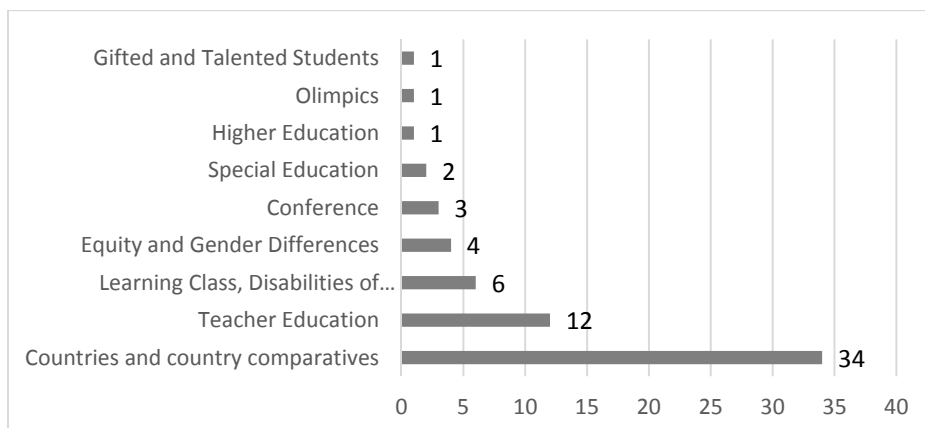

Graph 10. The Publications about General Education Situations

It is seen in Graph 10 that 34 publications were about countries and comparisons of countries. It is also found that 12 of the publications were about teacher education. This category is followed by the publications about learning environments, mathematical difficulties and culture with 6 publications for each.

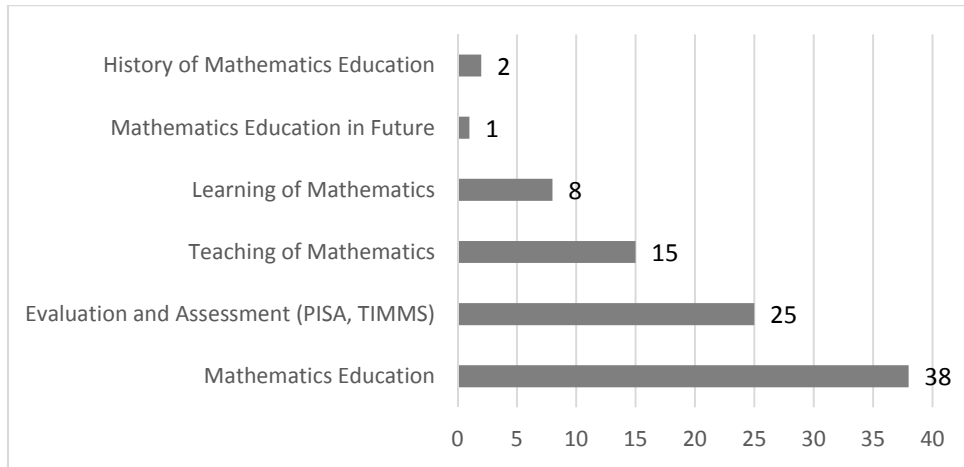

Graph 11. The Publications about Mathematics Education

It is seen that the number of the publications about mathematics education was much more than the number of other sub-categories in the theme of mathematics education (See Graph 11). It is found that there were 38 publications about mathematics education on UNESCO data base. This sub-category was followed by measurement-evaluation with 25 publications. Between the years of 1989 and 2013, 15 publications were published about mathematics teaching and 8 publications were published about mathematics learning. It is seen that there were only 2 publications about mathematics education history about which more publications have been published with increasing importance in recent years. Moreover only 1 publication was published about mathematics education in future. When it is compared with other sub-categories in the theme of mathematics education, the fewness of the numbers of the publications about mathematics education history and mathematics education in future was striking (See Graph 11).

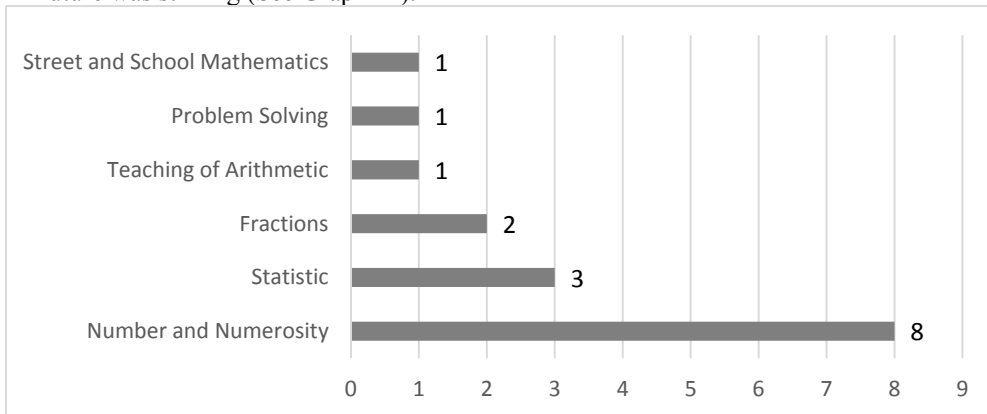

Graph 12. The Publications about Subject Areas

It is seen in Graph 12 that the number of the publications in the theme of subject areas including sub-areas of mathematics was the most in the sub-category of number and numerosity. 8 publications were published in the sub-category of number and counting between the years of 1989 and 2013. This sub-category was followed by the sub-category of statistics with 3 publications and the sub-category of fractions with 2 publications. It is seen that only 1 publication (for each) was published in the sub-categories of street and school mathematics, problem solving and arithmetic.

6. The Distribution of the Publications of UNESCO about Mathematics Education according to Accessibility (Online Access)

When the publications were examined, it is seen that some of the publications on UNESCO website had online access. The publications were examined under two categories to investigate the accessibility of the publications (See Table 5).

Table 5. The Distributions of the Publications about Mathematics Education on UNESCO Website according to the Accessibility (Online Access)

Year	Online Access	Non-Online Access
1989-1997	61	31
1998-2005	57	33
2006-2013	29	61
Total	147	125

When Table 5 was examined, it is seen that the number of the publications having online access was the most between the years of 1989 and 1997. It is also found that that the number of the publications not having online access was the most between the years of 2006 and 2013. Moreover, it is seen that the numbers of publications having online access have been decreasing from past to present.

DISCUSSION AND CONCLUSION

In this study, evaluating the publications about mathematics education on UNESDOC database, 272 publications were reached. Only 147 of these publications were accessed online. Some of the publications of the rest were not included on data base and some were accessed by user name and password. It is thought that accessing some publications by user name and password contradicts with the identity of the organization because of the fact that the organization is known as a nonprofit and international education, science and culture organization. Since such implementations prevent people to access the publications. When the publications were examined according to years, it was seen that online accessibility decreased. In this era that technology has been developing continuously and becoming an information society, accessing data is provided in digital environments. Despite this, while more publications were accessed online in the past, online accessibility of the publications has been decreasing from past to present.

Another finding revealed that the distribution of the publications according to years was consistent. When the publications were examined according to years, it was found that nearly 90 publications existed for each group. It was appeared that there were more publications especially in 1992 and 2006. The reason of existing more publications in 1992 and 2006 may arise from the fact that countries evaluate their own mathematical education more after the publication and revision of “Principles and Standards for School Mathematics” document by NCTM in 1989 and 2000.

As a result of analysis of investigated publications according to subject areas, it was found that the publications focused mostly on “Mathematics Education” and “Education Programs” topics. “Mathematics Course Education Programs” was the topic that the most publications were published. It is found that in recent years many publications related to situations of countries have also published as measurement and international evaluation reports like PISA, TIMSS were published. Moreover, it was appeared that there were no more publications about sub-areas in mathematics (arithmetic, algebra, problem solving etc.). According to purpose of establishment of UNESCO, it is also aimed to be developed educational systems of countries. Despite this purpose, it is surprising that there was only one publication about how future mathematics education should be. Moreover, it also contradicts with the aim of UNESCO focusing also differences among cultures that only 4 publications existed related to equality and gender differences in mathematics education.

It is seen that there were more publications in the countries located in the continents of America and Asia. When the publications on UNESDOC data base were examined, it is appeared that the ratio of numbers of countries in each continent where publications were published to the numbers of countries in the continents was 25-35 %. It is thought that the ratio of countries publishing publications was less in Africa because of the fact that the number of countries in Africa is more. It is seen that although the ratio of countries where publications were published was less, the number of publications (4,43 publications) per country was more. It is appeared that the continent where more publications existed was Europe with 5 publications. Similarly, it is found that number of publications per country was also high in America with 4,71 publications. It is seen that although in the continent of Asia, the ratio of the number of countries where publications published to all countries in this

continent was approximately 35%, the number of publications per country was the least among the continents with 2,18 publications.

When the publications were examined, it is found that the number of publications published in France was the most with 19 publications among other countries. The reason may be the fact that the central office and library of UNESCO place in this country. Moreover, it is revealed that the number of publications was also high in less developed countries as Antigua and Barbuda (10 publications), Bahamas (9 publications) publications) and South Africa (9 publications) as well as they were published in developed countries as the United Kingdom (16 publications) and the United States of America (13 publications).

When the publications were examined, it is seen that especially the publications published between the years of 1989 and 1997 were published within the scope of series. It is revealed that the number of publications published in series had decreased from past to present and they were published as independent publications. When the series of publications were examined, it is found that the number of the publications in “Moving into the twenty-first century” series was the most. It was followed by the series of “Science and technology education” and “Prospects: quarterly review of comparative education”. However, the numbers of publications were the least in the series of “Science and technology in school curricula, Higher education in Europe, Innovations in science and technology education, Technical paper etc.”

REFERENCES

- Altun, A. & Ata, B. (2012). Unesco'nun tarih eğitimi yayınlarına yönelik bir değerlendirme (1947-2012). *Adıyaman Üniversitesi Sosyal Bilimler Enstitüsü Dergisi*, 6, (14).
- Yıldırım, A. & Şimşek, H. (2011). Sosyal Bilimlerde Nitel Araştırma Yöntemleri. Ankara: Seçkin Yayıncılık.
- Huxley, J. (1946). UNESCO: Its Purpose and Its Philosophy. Preparatory Commission of the UNESCO. Accessed on 15th April from UNESDOC data base.

INTEGRATING MATHEMATICS AND SCIENCE WITH ICT: A PROBLEM-CENTERING STRATEGY IN A GREEK SECONDARY SCHOOL

Kleopatra NIKOLOPOULOU
University of Athens and Secondary Education, Athens, Greece
klnikolopoulou@ath.forthnet.gr

Dimitrios DIAMANTIDIS
Secondary Education, Athens, Greece
dimdiam@sch.gr

ABSTRACT: This paper discusses a problem-centering strategy in integrating mathematics and science with ICT in a secondary school, in Greece. Integration involves establishing ties between scientific and mathematical sub-fields. The problem-centering strategy involves enlisting the knowledge in two or more disciplines to address particular tangible and real-world problems. In this pilot study, the problem-centering strategy was applied to two classrooms of a secondary school in Athens. Its advantage was that it brought together the disciplines of mathematics and science with ICT use (as a tool). Pupils, aged 13-14 years old, carried out learning activities integrating mathematics and physics in a computer environment using the “Geogebra” software. The learning activities focused on resolving tangible problems. This approach seemed to have improved pupils’ motivation to learn mathematics.

Key words: mathematics, science, ICT, problem-centering strategy, interdisciplinary approach

INTRODUCTION

Several studies back the benefits of incorporating a multi-disciplinary curriculum. Research in the area of education, as well as in cognitive science, suggests that curriculum variations featuring an inter-disciplinary curriculum are likely to promote more learning (Loepp, 1999). Throughout the 1990's, curriculum integration and its application has been a consistent and important theme in education reform strategies, yet very few schools have adopted this reform in practice (Wisconsin Department of Public Instruction, 1999). This has happened despite praise from parents and pupils who describe the approach as valuable and challenging (Reid & Feldhaus, 2007); despite recommendations from many experts in the field and standards initiatives in science, mathematics, and technology that call for implementation of a multi-disciplinary approach; and despite research that shows integrating the math, science, and technology education curriculum helps pupils across a wide range of academic achievement (Wicklein & Schell, 1995; Bailey, 1997).

This paper discusses a problem-centering strategy in integrating mathematics and physics with ICT in a secondary school, in Greece. This is an introductory pilot study, since we still collect data from classroom practices. Three terms which are relevant to the study are defined here, for clarity. *Integrated Curriculum* - Two or more teachers from different disciplines working together to coordinate their course instruction, develop materials, link academic and occupational skills, and develop varied instructional strategies (Wisconsin Department of Public Instruction, 1999). *Interdisciplinary Curriculum* - A term that can mean any of the following: (i) Applying methods and language from more than one academic discipline to examine a theme, issue, question, problem, topic, or experience. Interdisciplinary curriculum creates connections between traditionally discrete disciplines such as mathematics, the sciences, social studies, or language. An interdisciplinary curriculum may be pursued by individual teachers working on a particular unit or among teachers planning together, (ii) The process teachers use to organize and transfer knowledge under a united theme (Maurer, 1994). Finally the term *ICT (Information and Communication Technology)* is used as synonymous to *computers* and *technology*.

INTERDISCIPLINARY APPROACHES IN THE LITERATURE

Several studies support the benefits of incorporating a multi-disciplinary (or interdisciplinary) curriculum. Wicklein and Schell (1995) performed four separate case studies using a multidisciplinary approach to mathematics, science, and technology education. The goals of these case studies included increasing the interest level of the pupils in these subject areas, to help teachers to understand that their particular instructional areas did not stand alone within the curricular offerings, to improve pupils' attendance in school, and to transfer

learning to unique problems. Through the application of "hands-on and minds-on" curriculum, the pupils understood the practical uses of the three instructional areas (Project Lead the Way, 2007-2008). For example, pupils were able to see direct applications of math and science to their everyday life through a variety of technology-based activities. Students demonstrated more motivation by reducing their absences from school and discipline problems based on the school records from the previous year. Furthermore, pupils demonstrated an appreciation for the structured learning activities, were able to perceive the importance of working together to solve a common problem, were able to appreciate the occupational strategies of modern businesses and industries, and demonstrated an improvement in self-esteem (Wicklein & Schell, 1995; Rossiter, 2002). The findings from this case study were not limited to pupil improvements. Faculty agreed that a multi-disciplinary approach created a learning atmosphere that provided pupil with a unique opportunity to learn in a much broader context. In addition, it allowed them to teach more effectively by revealing that pupils had been trained to dismiss subject matter learned in one classroom as having little or no relevancy to another. Research has also reported that motivation for learning increased when pupils worked on real-problem elements. When pupils were actively involved in planning their learning and in making choices, they were more motivated and exhibited fewer behavior problems. A multi-disciplinary curriculum was consistent with increased self-direction, improved attendance, higher levels of homework completion, and a more positive outlook towards school and academics. Inter-disciplinary education curriculum helped pupils make connections, solve problems and addressed better pupils' learning styles.

It is a challenging -but not an easy- task to integrate mathematics and science into the rest of the secondary school curriculum. The challenge comes from the specialization of knowledge in these areas, the use of different sets of terminology, as well as a tradition of teaching these subjects in a way that emphasizes singular facts and precise tools over broad concepts and generalizable ideas. Even within the sciences and mathematics, the separation between the different sub-fields is so rigorously maintained and the boundaries so clearly drawn, that the internal integration within them is not a minor task. Integration involves establishing ties between scientific and mathematical sub-fields. Furthermore, all too often such sub-fields are represented as (indeed reduced to) collections of facts and formulas to be utilized to address decontextualized problems. Higher levels of disciplinary thinking (e.g., developing mathematical proofs or constructing original testable hypotheses) are noticeably absent from many mathematics and science classrooms.

An integration strategy /approach to the teaching of science and mathematics in integrative ways, is proposed here. This strategy, which we call problem-centering strategy, involves enlisting the knowledge and modes of thinking in two or more disciplines (e.g., science, mathematics,) to address particular problems, develop specific products, or propose a course of action. For example, a way to teach evolution in an integrative way is to present pupils with a tangible problem that could be solved with the help of some aspects of evolutionary theory. This would constitute a problem-centered approach to integrating material on evolution.

A PROBLEM-CENTERING STRATEGY IN MATHEMATICS AND SCIENCE

Focus on a tangible and real-world problem rather than on enhancing disciplinary understanding, defines the problem-centering strategy and determines a special kind of relationship among the disciplines. Problem-based learning is the pedagogy that we tried to apply in some classrooms of our school. Problem-centering of the curriculum is applicable in different classrooms. Problem-centering can bring different fields in close interaction with one another and thus foster broad external connections between the sciences and other fields. Although problem-centered learning could be part of any classroom, some disciplines seem to be more regular and consistent users of this strategy. These tend to be science disciplines, such as biology or physics, which target a problem as the subject of their analysis. Addressing a tangible and real-world problem involves mapping the problem territory, bringing together all of the relevant disciplinary tools in order to provide a rich description of the problem, isolate its "primary issue," and define what the solution might be. In the process of generating an answer from these various sources, pupils confront differences in perspective and have to reconcile them. Thus, the final report is a synthesis of mathematics, science and other disciplines. The advantage of this pragmatic orientation toward interdisciplinary interaction is that it brings together a wide range of disciplines.

The scientific /mathematical tools and procedures are engaged in the problem-centering approach thoroughly, if not extensively. As a result, the pupil might actually perfect his/her skill of statistical analysis or learn more about molecular weights as he/she assesses the contamination of groundwater. When mastery of disciplinary tools serves a compelling problem, significant and highly motivated learning of mathematical and scientific theories can occur. Problem-centering tends to be a transferable strategy. It offers the point of connection that provides motivation for negotiating and reconciling disciplinary differences. Science and math often find themselves as valuable partners in this conversation as they lend tools and practices for collective inquiry into a

complex issue. The strengths of this strategy include: pupils' attention and creativity are fully mobilized by the urgency of the problem; □ it inspires activist approach to learning and knowledge in pupils; motivation and thorough mastery of the disciplinary content (e.g., facts, practices, theories) occurs as a result; unrelated disciplines come together easily in this strategy, as differences between them are addressed decisively and pragmatically. In parallel, there are some weaknesses of the problem-centering strategy: learning is highly targeted to the problem and therefore coverage of the field is limited to relevant tools and theories only; reflection and deliberation on the discrepancies in the disciplinary approaches is minimal.

Problem-centering uses an ill-structured problem, rather than history or culture, as a point of connection between science or mathematics and any other discipline. It makes connections between ideas precise and pragmatically relevant. No investigation of broader disciplinary context of the issue or different tools is typically undertaken, nor does one typically spend much time on concept-building or deriving historical meaning from mathematical or scientific data in this model. Problem-centering, as a strategy, pursues a clearly defined goal: to resolve an urgent, tangible, and complex problem that invites or demands input from several fields. The problem-centering strategy/ approach is aimed at generating critical action. The integrative strength of this model lies in its flexibility to reach out and include a wide spectrum of disciplines as well as to encourage the mastery of disciplinary content. The blind spot of this strategy could be the pragmatic narrowness of the disciplinary exploration. Nevertheless, the motivational and integrative power of this strategy is notable.

ICT Integration in Secondary Science and Mathematics

The distinction between teaching ICT (or computers, or Information Technology) as a discrete subject and teaching different (other than ICT) subjects with/via the use of ICT is widely known. In this paper we refer to the latter case, and more specifically, the ICT use/ integration in science and mathematics lessons. Research findings suggest that ICT in secondary science, particularly in the form of simulations or animations of processes, provides a range of affordances for learning science (e.g., Webb & Cox, 2004). Computer science software allows pupils to visualize and understand phenomena that cannot easily be observed or allows pupils in constructing and interpreting graphs (e.g., of speed over time). For example, research showed that through using simulations pupils gained understanding of physical phenomena involving interacting variables, enabled pupils to perform at higher cognitive levels and promoted conceptual change (Jimoyiannis & Komis, 2001; Nikolopoulou, 2000). Cox and Nikolopoulou (1997) showed that computer based data analysis software helped 13-14 year old pupils to perform a range of intellectually advanced/ complex data analysis tasks, such as classifying data according to different criteria.

Regarding ICT use/ integration in secondary mathematics classrooms, there have also been research studies which provide evidence of a positive effect of ICT on pupils' attainment. Important affordances of ICT in mathematics are associated with investigations where pupils explore, conjecture, construct and explain relationships. The use of software to support exploration of quadratic functions with an open learning environment allows pupils to explore within a framework. Effective pedagogical practices in these contexts are promoting pupils' interaction with the task and with each other. For example, Jones (2002) reported that interacting with dynamic geometry systems can help pupils to explore, conjecture and explain geometrical relationships. It can provide them with the basis from which to build deductive proofs. Hennessy (2000) working with graphing, observed that the graph plotting became very simple, and the learning gains were greatest in the area of determining intercept, interpolation and finding range from a graph.

Evidence suggests that different types of ICT use provide different affordances for pupils' learning in different subject areas. We emphasize that when ICT is integrated in science or mathematics classrooms there are various factors that impact on pupils' learning such as the type of the software, the pedagogical practices, classroom interactions (e.g., collaborative learning) and the teachers' beliefs, skills and knowledge.

THE STUDY

Sample and Procedure

As discussed earlier this is a pilot study, as we still collect data for the main study. The authors of this paper are mathematics and physics teacher respectively and decided to integrate mathematics and physics using ICT as a tool, in two classes. Both classes held 56 pupils aged 13-14 years old (i.e. attending the 2nd year of the Greek secondary school), and the pilot study was carried out during the autumn term 2013-14. The school is a "pilot experimental" high school (pupils aged 12-15 years old) and its policy encourages teachers to apply and evaluate experimental strategies/ approaches in their classroom practices. Thus, an interdisciplinary approach to

mathematics and science is positioned within the school's acceptable educational practices. We planned together and we worked on particular units of our subjects (mathematics and physics).

Examples of Topics

Table 1 shows examples of topics which involve mathematics and physics, as well as indicative pupils' tasks and relevant corresponding mathematic learning objectives. The topics shown are indicative and these are included in the curriculum we follow in the school for pupils aged 13-14 years old. The problem-centering approach may improve pupils' motivation to learn mathematics. For example, pupils who do not enjoy learning the vectors unit (or find it useless), may start using vectors to solve geometry problems, or mechanics problems in physics – understanding better the operations with vectors. Moreover, pupils who may not like mathematics but are good at physics can see the vectors' applicability to physics and start thinking that learning maths supports them in understanding physics (e.g., velocities and forces).

Table 1. Examples of topics which involve both mathematics and physics

Topic	Pupils' tasks	Mathematic objectives	learning
Quadratic functions	<ul style="list-style-type: none"> - pupils watch the video of the freely falling ball experiment and use the freely falling ball graph (position depending on time) - by reading the graph, pupils identify the position of the ball at different moments, the interval of time between two different positions of the ball, the domain and co-domain of the function, axes intercepts and their meaning related to the experiment, coordinates of the vertex point, monotonicity of the function, the image of the function - pupils calculate the 2nd degree polynomial which defines the graphed function 	<ul style="list-style-type: none"> - pupils interpret functions from graphs - analyze quadratic functions to describe the motion of an object - identify applicability of quadratic functions 	
Vectors	<ul style="list-style-type: none"> - pupils explain the solution of the two vectors problems (use of addition vectors tools to solve relative velocity) - the problems could be available on a website proposed to pupils 	<ul style="list-style-type: none"> - pupils use addition of vectors to solve problems in nonmathematical context - identify applicability of vectors 	

Indicative Learning Activities with ICT

Figure 1 shows two screen shots from learning activities integrating mathematics with physics in a computer environment, using the "Geogebra" software. Geogebra is a DAS (Dynamic Algebra Systems) which combines dynamic manipulation of a representation (i.e., a graph) with the functionalities of a CAS (Computer Algebra System) (Noss et al., 1997). The most important tool of DAS used in the following activity was the variation tool. Graphical representations of equations such as $v=S/t$ which is a line that passes through the origin $O(0, 0)$. The main advantage is that when pupils manipulate the variation tool, the result leaves its traces on the screen. One problem posed to the pupils was to calculate the velocities of a hare and a turtle, as well as to determine the position of each animal on specific time (i.e., on the 5th minute). In the beginning of this activity students are asked which one of the two lines (the green or the red one) is the graph of distance (S) over time (t) with greater velocity than the other. Students using the variation tool, manipulate time as a variable "t". Then, they can see that the distance of the corresponding points on S axis increases, as time passes; which means that velocity represented by the green line is greater. They can form the assumption that the slope of the line is related with the velocity of the moving object. Thus, the relation between slope of the line and velocity help students to embody (Tall, 2004) the relation between slope of the line and ratio of proportions. Of course the next step is proving the relation using symbols of algebra.

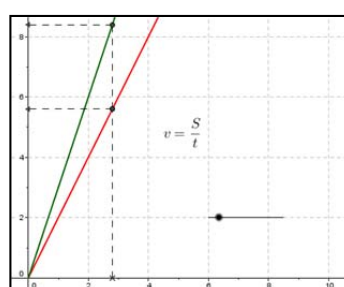
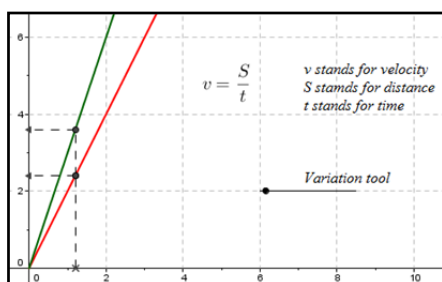

Figure 1. Learning Activity Integrating Mathematics with Physics, using “Geogebra” Software CONCLUDING REMARKS

This pilot study revealed that pupils enjoyed seeing applications of mathematics and physics in real-world problems (and this is in agreement with relevant literature). Some of the pupils, who under other circumstances were not motivated, did show increased motivation. However, this was a pilot study with several limitations. The sample was small and we did not gather data on pupils' academic achievement on accomplishing the tasks. In our main study we aim to apply the strategy to more classes, for a longer period of time, and to also collect data on pupils' perceptions and self-esteem. We aim to apply the problem-centering strategy to younger pupils (12-13 years old) studying the topic of temperature, via integrating mathematics with physics. This is an interesting topic as among the curriculum objectives are, for pupils to construct and interpret graphs of temperature versus time.

A problem-centering strategy/ approach could be extended to other school subjects, in the school. For example, mathematics and science teachers can learn from the humanities subject about the history of ideas in their fields, and focus on problems from the real world. Conversely, a problem-centering pedagogy would profit from a richer historical context. At the same time, teachers in other schools and in any subject area can benefit from keener awareness of the different frameworks that they have available to them as they design their own interdisciplinary curricula. For example, by inviting science/ mathematics and social science teachers to provide a historic context for scientific discoveries, for example, or by problem-centering of the inquiry. They will have to search for hybrid ways to build a particularly effective interdisciplinary exchange that reflects their teaching goals.

REFERENCES

- Bailey, T. (1997). *Integrating academic and industrial skill standards*. Berkley: National Center for Research in Vocational Education, University of California.
- Cox, M., & Nikolopoulou, K. (1997). What information handling skills are promoted by the use of data analysis software? *Education and Information Technologies*, 2 (2), 105-120.
- Hennessy, S. (2000). Graphing Investigations Using Portable (Palmtop) Technology. *Journal of Computer Assisted Learning*, 16, 243-258.
- Jimoyiannis, A., & Komis, V. (2001). Computer Simulations in Physics Teaching and Learning: a case study on students' understanding of trajectory motion. *Computers & Education*, 36, 183-204.
- Jones, K. (2002). Implications for the Classroom. *MicroMath*, 18, 18-20.
- Loepp, F. (1999). Models of curriculum integration. *Journal of Technology Studies*, 25(2), 45-49.
- Maurer, R. (1994). *Designing interdisciplinary curriculum in middle, junior high, and high schools*. Boston, MA: Allyn and Bacon.
- Nikolopoulou, K. (2000). Development of pupils' classification skills in science lessons: an intervention of computer use. *Journal of Science Education and Technology*, 9(2), 141-148.
- Noss, R., Healy, L., & Hoyles, C. (1997). The Construction of Mathematical Meanings: Connecting the Visual with the Symbolic. *Educational Studies in Mathematics*, 33, 203-233.
- Project Lead The Way. (2007-2008). *Curriculum philosophy. The PLTW curriculum: How and why it works*. Retrieved from <http://www.lancasterschools.org/Page/554>
- Reid, K., & Feldhaus, C. (2007). Issues for universities working with K-12 institutions implementing prepackaged pre-engineering curricula such as Project Lead The Way. *Journal of STEM Education*, 8(3&4), 5-11.
- Rossiter, D. (2002). *Perceptions of mathematics, science, and technology teachers of an interdisciplinary curriculum in a middle school*. Retrieved from www.uwstout.edu/lib/thesis/200212002rossiterd.pdf
- Tall, D. (2004). Introducing Three Worlds of Mathematics. For the Learning of Mathematics, 23(3), 29-33.
- Webb, M., & Cox, M. (2004). A Review of Pedagogy Related to Information and Communications Technology. *Technology, Pedagogy and Education*, 13(3), 235-286.
- Wicklein, R., & Schell, J. (1995). Case studies of multidisciplinary approaches to integrating mathematics science and technology education. *Journal of Technology Education*, 6(2). Retrieved from <http://scholar.lib.vt.edu/ejournals/JTE/v6n2/wicklein.jte-v6n2.html>
- Wisconsin Department of Public Instruction. (1999). *Selected integrated and applied curricula in Wisconsin secondary schools 1999* (No. 99110). Madison, WI: Lifework Education Team Department of Public Instruction.

SCIENCE TEACHERS' PERSPECTIVES ON BENEFITS AND PROBLEMS FACED USING TABLET COMPUTERS IN SCIENCE EDUCATION: THE STORY FROM A SECONDARY SCHOOL IN TURKEY

Sila KAYA

Jocelyn WISHART

Over the past decades, the importance of using tablet computers (TPCs) in science education has increased as it fulfils a goal common to both science education and Information and Communication Technology use in education. Teachers are the first implementers of the educational developments; therefore science teachers' perspectives on using TPC in science education play a key role. In this study, 9 science teachers are interviewed to gain a rich picture of the benefits arising from and problems faced in deploying TPCs in teaching. The TPCs were used mostly for time saving activities and whilst many findings were in line with the literature on obstacles such as infrastructure problems and their benefits such as supporting science classes through multimedia, especially visual images, there was a discrepancy, mainly based on the students' motivation. It was found that giving out TPCs without including a way of the teacher being able to monitor the students' activities caused pedagogical, technical and management problems. The literature regarding teachers' opinion on the relationship between teachers' prior knowledge and ease of use of a TPC has been extended by this exploratory study.

Keywords: Implementation of Tablet Computers; Science Education; Pedagogical, Technical and Management Issues: Teacher's Perspectives

ORTAOKUL 6. SINIF ÖĞRENCİLERİN MATEMATİĞE VE MATEMATİKÇİLERE BAKIŞ AÇILARI

Nevin SÖKMEN

Türk Dil Kurumuna göre Matematik “Aritmetik, cebir, geometri gibi sayı ve ölçü temeline dayanarak niceliklerin özelliklerini inceleyen bilimlerin ortak adı” olarak tanımlanmıştır. “Matematik Nedir?” sorusu üzerinde aslında tam bir görüş birliği bulunmamaktadır. Sawyer’ a göre “matematik, tüm olası modellerin incelenmesidir.” Boole’ a göre ise “matematiğin özü, sayı ve miktarla ilgili düşüncelerle çalışmak değildir. Matematik, kullanılabilecek yollardan bağımsız olarak kendi içinde hesaba katılan uygulamalarla ilgilidir.” Freundenthal ise matematiği “Matematik, deneyim alanlarını organize etme etkinliğidir.” olarak ifade etmiştir. Matematik üzerine farklı tanımlamalarının nedeni matematiğe karşı farklı bakış açılarından ve deneyimlerden kaynaklanmaktadır.

Matematiğin özelliklerini bilmek, matematiği daha iyi anlamaya yardımcı olacaktır. Matematiğin, insan beyninin ürettiği bir soyutlama olması, kendisine özgü bir dili olması, ardışık ve yığılmalı bir bilim olması, diğer bilimler tarafından kullanılan bir araç olması, matematiğin özelliklerinden bir kaçını sıralanabilir.

Öğrencilerin matematik ve matematikçiler hakkında çok olumlu bakış açıları olmadığı bilinmektedir. Öğrencilerin matematikle ilgili yaşantılarının (sınav başarıları, öğretmenleri, ders kitapları, matematik dersleri, vb.) matematik ve matematikçi hakkındaki bakış açılarını etkilediği görülmüştür. Ülkemizde son yıllarda okutulan matematik ders kitaplarında ünlü matematikçilere ve matematik tarihine belirli oranda yer verilmektedir. Bu yolla matematiğe karşı ilginin artacağı düşünülmektedir. Bununla beraber öğrencilerin matematik ve matematikçi ile ilgili bakış açıları hala merak konusudur.

Bu çalışmada, ortaokul 6. sınıf öğrencilerinin matematik ve matematikçilere bakış açıları incelenmiştir. Çalışma, Eskişehir merkez bir ortaokul 6. Sınıfına devam eden 40 öğrencinin katılımı ile gerçekleştirilmiştir. Öğrencilere en az 4 ünlü matematikçinin bir arada olduğu hikâye yazmaları istenmiştir.

Yazılan hikâyeler, yer verilen matematikçiler, olaylar, zaman dilimi gibi kriterler açısından incelenerek öğrencilerin matematiğe ve matematikçilere bakış açıları belirlenmeye çalışılmıştır.

Anahtar Kelimeler: Öğrenci Görüşleri, Matematik, Matematik Eğitimi, 6. Sınıf

oooooooooooooooo

THE PERSPECTIVE OF 6TH GRADE STUDENTS TO MATHEMATICS AND MATHEMATICIANS

Nevin SÖKMEN

According to the Turkish Language Association Mathematics is defined as the “ common name of the sciences investigating the properties of the characteristics of arithmetics, algebra, geometry and such which are based on numbers and measures”. There is actually no agreement on the answer to the question “What is Mathematics?” According to Sawyer “mathematics is the examination of all possible models”. Boole defines mathematics as “not the study of notions relating to numbers and quantities in its essence. Mathematics is concerned with applications on their own sake, without explicit reference to and independent of the means used”. Freundenthal, on the other hand, defines it as “the activity of organizing the area of experiences”. These different definitions of Mathematics differ due to different point of views and experiences. Mathematics can be better understood through learning its essential properties. A few of its properties can be listed as it being the abstraction of of the brain, that it has its own language, it is a sequential and cumulative science, and a tool used by other disciplines. It is known that student do not have a positive view of mathematics and mathematicians. It has been observed that these views are affected by their experiences (success in exams, teachers, text books, mathematics lectures, etc.) of mathematics. In recent years, text books used in our Country’s schools consist a certain percentage of famous mathematicians and history of mathematics which is thought and accepted to increase the interest in mathematics. Still yet, it is a curious matter how pupils consider mathematics and mathematicians. In this study, the point of view of 6th graders has been considered. The work is carried out in

Eskişehir, at a central school, with the participation of 40 6th grade students. The students were asked to tell a story containing at least four famous mathematicians. The stories told are investigated in terms of the mathematicians included, events, time spans, and the students' points of views has been tried to be determined.

Keywords: Student's Openion, Mathematics, Math Education,

A NEW METHOD FOR SOLVING BLACK-SCHOLES PARTIAL DIFFERENTIAL EQUATION

Zieneb Ali ELSHEGMANI

The closed-form analytical solution of the Black-Scholes of the arithmetic Asian options partial differential equation (PDE) is not known. This is due to the fact that, the arithmetic average of a set of lognormal random variables is not lognormally distributed. In this paper we study the analytical solution of the arithmetic Asian option PDE, that provide the Asian option pricing formula. we derive a closed-form solution for a continuous arithmetic Asian option by means of partial differential equations (PDEs). A new method for solving arithmetic Asian options PDEs using general transformation techniques is offered. The two dimensions PDE of the arithmetic Asian options are reduced to the classical Black-Scholes PDE with one dimension. In addition, Mellin transform is used to obtain the final solution to the arithmetic Asian option PDE. Using general transformation techniques, we transform the degenerate arithmetic Asian option PDE to the simplest heat equation, that has a known solution

Keywords: Black-Scholes PDE, arithmetic Asian option, Mellin transform

PREDICTING STUDENTS' ACADEMIC PERFORMANCE USING ARTIFICIAL NEURAL NETWORK : A CASE STUDY FROM FACULTY OF ORGANIZATIONAL SCIENCES

Sonja ISLJAMOVIC
Faculty of Organizational Sciences, University of Belgrade
sonjaisljamovic@gmail.com

Milija SUKNOVIC
Faculty of Organizational Sciences, University of Belgrade
milijas@fon.bg.ac.rs

ABSTRACT: University students' retention and performance in higher education are important issues for educational institutions, educators, and students. Educational data mining is focused on developing models and methods for exploring data collected from educational environments in order to better understand and improve educational process. Analyzing and determining patterns among indicators of academic success (study grade point average) and their correlation to students' personal, high school, admission data can present be a good foundation in process to adapt and improve the curriculum of higher education institutions, according to the students' characteristics. In this paper we use different artificial neural network algorithms in order to find the best suited model for prediction of students' success at the end of their studies. Additionally, we identified which factors had the crucial influence on overall students' success. Data were collected from the graduated students of Faculty of Organizational Sciences, University of Belgrade.

Keywords: Educational data mining, student success, artificial neural network, university education

INTRODUCTION

Academic education represents one of the key roles in the process of a country modernization and achieving competitive advantage. The process of education and development of human resources is becoming increasingly important concept, by which it can be determinant success in business and in society as a whole unit. It can be said that the new social elite is coming from academic circles with the aim to stabilize and improve the overall state of the economy and society.

In this research, artificial neural networks are used in order to make a system for early prediction of the success of students based on their success on the exams on the first year of studies. Early prediction of students' success could help teachers to identify students that have potential for advanced courses and also students who need the additional education in order to improve their knowledge. On the other side, developed system could be useful for students, so that they could estimate their future success in their studies on the basis of their learning habits, their work and grades. This could help them to identify on time whether they need an additional effort in order to achieve the success they want.

The paper has following structure: Section 2 gives a review of the state-of-the-art for prediction of students' success with artificial neural networks. In Section 3, the structure and the function of artificial neural networks, as well as the efficient methodologies for prediction are explained. In Section 4, we present the experimental results of this research. Evolved models in this research are evaluated on the real data about students and their success on the Faculty of Organizational Sciences in Belgrade. In section 5, results are discussed and the directives for further researches are given.

SOLUTIONS FOR PREDICTING THE SUCCESS OF THE STUDENTS

The ability to predict the students' academic performance is very important in institution educational system, as well for faculty, university and educators, as well as for students. Data mining in the field of education (Educational Data Mining - EDM), as a new field of research, has developed in the last decade as a special area of application techniques and tools for detecting regularities and correlations in the data (data mining), with the aim of analyzing the unique data types that appear in educational system for solving various problems of educational and instructional improvement process (Romero & Ventura, 2007; Romero & Ventura, 2010). EDM is engaged in development, research and application of methods to detect regularities in the data in the database in the field of education, which would otherwise be difficult or almost impossible to analyze and determine the

dependency patterns of behavior and learning among students, primarily because of the large amount of data (Romero et al., 2010).

Applications of data mining techniques in educational environments are more and more popular area of research and there is an increasing number of research papers published in the last years (Minaei-Bidgoli & Punch, 2003; Schumacher et al., 2010; Etchells et al.; 2006; Ayesha et al., 2010; Wook et al., 2009). Researches in educational data mining area focus on different aspects of educational process: students, teachers, teaching aids, organization of teaching etc. (Falakmasir & Habibi, 2010; Kumar & Chadha, 2011; Romero & Ventura, 2007; Guruler et al., 2010). One of the main goals and the basic application fields of educational data mining can be classified into the following categories: Prediction of students' success, Organization of teaching programs, Prediction of enrolment of students to the higher level of educational program, Discovering cheating during an on-line examination, Identification of abnormal/extreme values in the educational system, (Kumar & Chadha, 2011). In order to achieve these goals, different algorithms of data mining are used, such as: decision trees, artificial neural networks (ANNs), k-nearest neighbor, naive Bayes, support vector machines, cluster algorithms, (Ayesha et al., 2010).

Traditionally, academic researchers have used statistic models and methods in order to predict the success of the students. Today, there are many different approaches about classifying the students and predicting their grades Gonzalez and DesJardins (2002) tried to predict the success of the students, using the linear regression and neural network models. The results of their research point that the models of logistic regression do not predict behavior of students equally well as the artificial neural network models. Thomas and Hass (2001), compared the performance of the three different techniques of data mining for predicting students' behavior: neural networks, cluster algorithms and decision trees, where the model based on neural network gave the best results. Delgado (Delgado et al., 2006) used neural networks to predict success of the students on the exams, defined with binary classes (pass or fail). Wook (Wook et al., 2009), compared two data mining techniques, ANN and the combination of clustering and decision tree classification techniques for predicting and classifying students' academic performance, and based on that research they identified the patterns that influence or affect the student's academic performance. Guo (Guo, 2010) used neural network for establishing dynamic models for analyzing and predicting student course satisfaction.

In paper of (Stathacopoulou et al., 2007) neural networks were used to add learning and generalization abilities to the fuzzy model by encoding teachers' experience through supervised neural network learning. The study of (Wu et al., 2008) indicates that a properly trained ANN classification model can be a strong predictor for use in the learning disabilities diagnosis procedure, and furthermore, a well-trained ANN model can also be used to verify whether a learning disabilities diagnosis procedure is adequate. Artificial neural networks for prediction of the number of secondary-school pupils who will continue university studies are used in (Gerasimović et al., 2001). Isljamovic (Isljamovic et al., 2012) compared several classification algorithms in order to predict if a student would display excellent performance (i.e. highest grades) on a selected course in technology enhanced learning environment. ANNs were among the best algorithms by several evaluation criteria.

ARTIFICIAL NEURAL NETWORKS USAGE

Artificial neural networks (ANNs) are, according to their structure, function and data processing, similar to biological neural networks and represent a relatively good technique which solves the problem of classification and prediction. ANN presents a collection of mathematical models which can simulate some of the characteristics of biological neural systems and have similarities with adaptive human learning. They are made of a great number of connected neurons (processing elements), connected by their ties which contain permeable (weight) coefficients that are, according to their role, similar to synapses. The neurons are organized in three levels: input layer, one or more hidden layers and output layer. ANN process information like biological neural networks, with the possibility of remembering, learning and removing errors with high speed of getting the solution, so that the neural networks can be used for solving complex problems, such as classification and prediction (Yeh, 1999). ANNs were successfully used in variety of disciplines for modeling complex and real problems (Liao & Wen, 2007).

In order to find the best quality model, we used six different methods for building neural network models:

- *Quick*: a method that uses rules of thumb and characteristics of data in order to choose an adequate topology of network;
- *Dynamic*: a method that automatically creates initial topology and then adds or takes away hidden nodes during training;

- *Multiple*: a method that creates several networks with different topologies, where the exact number depends on quantity of training data. These networks are trained in parallel and the model with the smallest error is represented as the final model.
- *Prune*: a method that initially creates large network (with a lot of hidden layers and nodes) and then removes the weakest units from the input and hidden layers. This method is usually slow, but very often gives better results than the other methods.
- *RBFN (radial basis function network)*: uses a technique similar to k-means algorithm of clustering in order to separate data in accordance with output variable.
- *Exhaustive prune*: a method very similar to Prune method, that initially creates a large network (with a lot of different layers and nodes), and then removes the weakest units from the input and hidden layers. Parameters for this method are adjusted so that they ensure a very detailed search of possible model's space, in order to find the best possible model. This method is the slowest, but usually gives the best results.

In this research, software package Clementine (SPSS) was used for ANN developed as one of temporarily the most efficient and most effective software solutions which enable data mining, as well as quick development of predicting model, with a high quality. Data processing in Clementine is being done by using different kinds of nodes which are connected, forming a certain flow of data over which data mining and prediction are being done.

STUDENT SUCCESS PREDICTION – CASE STUDY

Research study performed on the Faculty of Organizational Sciences, which represents one of leading faculties, is in group of faculties of technology and engineering sciences of University of Belgrade. Faculty of Organizational Sciences is a higher education institution that deals with education, scientific research and consultancy through development of knowledge and skills in management, information systems and technology with the aim to enable future professionals to develop potentials of commerce and society. This research includes the first five generations of students, with 1787 graduated student, who have been registered in accordance to the principles of higher education implemented by the use of the Bologna Declaration, which had completed their studies by November, 2013. In this time frame more than 60% of enrolled students have graduated, achieving an overall Grade point average (GPA) of 8.63 on average time of study almost 5 years.

As an input data (predictors), 15 variables were used and represent data correlated to students' personal characteristics (students' gender), high school information (high school GPA and high school type), admission data (entrance examination points) and the first year examination grades (individual grades at 11 examinations of the first year of elementary studies). On the other side, as an output from neural network, we used a GPA at the end of their studies. Ratio between the training data and the testing data was 80:20. Model evaluation is performed on so far non-used data.

Performances of developed models are measured by Absolute average error, Standard deviation and Linear correlation. Results and performance of developed ANN are presented in Table 1. The best values for each criteria of comparison are shown in bold font.

Table 1. Results of developed ANNs (6 algorithms)

<i>Algorithm</i>	<i>Absolute average error</i>	<i>Standard Deviation</i>	<i>Linear correlation</i>
<i>Quick</i>	0.233	0.295	0.893
<i>Dynamic</i>	0.239	0.300	0.889
<i>Multiple</i>	0.234	0.294	0.892
<i>Prune</i>	0.238	0.297	0.892
<i>RBFN</i>	0.259	0.324	0.873
<i>Exhaustive Prune</i>	0.231	0.293	0.894

Comparative analysis of the results, on the test sample, showed that the developed ANN gives acceptable results. An absolute average error of prediction in all the networks is from 0.231 to 0.259 and the linear correlation coefficient is always over 87%. Exhaustive Prune stands out as the best algorithm by all criteria, giving the smallest absolute average error (0.231, the smallest standard deviation (0.293), and at the same time, the largest linear correlation coefficient (89.4%). A developed multilayer neural network with Exhaustive Prune method consists of input layer with 15 variables, output layer with one variable and two hidden layers with 30 and 20 neurons. Results with best ANN indicate that in almost 90% system will correct predict final student

GPA, which represent more than good precision in prediction, especially if we know that GPA will be round on one or two decimals, then standard deviation will have even less influence to final result.

With usage of ANN give as one more advantage compared to some other data mining methods and technique, which is represented in calculation of relative importance of the input variables for predicting an output variable. In order to identify the major influenced factors of students' success, we used this advantage of ANN. Importance of the attributes of the developed ANN model are given in Table 2. It can be seen that 6 firstly ranked attributes within the developed model are considered as the most important (relative value over 0.1).

By doing further analysis, we can conclude that grades on the exam in the first semester of studies have a great influence to overall success of studies, as well as data from high school (High school type and High school GPA), where both groups of variables achieved importance over 0.1. On the other side, as it can be seen from Table 2, gender of the students and entrance examination points are not of the greatest importance for predicting student's success. Also some grades from the first year exams, especially on subjects form second semester had small influence on it, such as Management, Economy and Psychology/Sociology.

Table 2. Relative importance of the input variables

<i>Input variable</i>	<i>Relative importance</i>
Mathematics 1	0.1223
Basics of information-communicational technologies	0.1103
High school type	0.1072
Basics of organization	0.1034
High school GPA	0.1024
Introduction into the informational systems	0.1004
Production systems	0.0602
Mathematics 2	0.0513
English language 1	0.0502
Entrance examination points	0.0426
English language 2	0.0411
Management	0.0402
Student gender	0.0343
Economy	0.0215
Psychology/Sociology	0.0126

After selection of 6 the most important input variables, we repeated process of predicting GPA only with that 6 variables, in order to examine potential performance of prediction model with less input variables. Results and performance of developed ANN are presented in Table 3, by using same performance measurements.

Table 3. Results of developed ANNs (6 algorithms with 6 input variables)

<i>Algorithm</i>	<i>Absolute average error</i>	<i>Standard Deviation</i>	<i>Linear correlation</i>
<i>Quick</i>	0.259	0.323	0.886
<i>Dynamic</i>	0.262	0.330	0.881
<i>Multiple</i>	0.255	0.319	0.889
<i>Prune</i>	0.259	0.323	0.886
<i>RBFN</i>	0.294	0.367	0.849
<i>Exhaustive Prune</i>	0.253	0.317	0.890

Developed models with reduces number of input also gave satisfactory results. Once more, Exhaustive Prune stands out as the best algorithm by all criteria, giving the smallest absolute average error (0.253, the smallest standard deviation (0.317), and at the same time, the largest linear correlation coefficient (89%). A developed multilayer neural network with Exhaustive Prune method consists of input layer with 6 variables, output layer with one variable and two hidden layers with 24 and 18 neurons. Comparing two developed ANN with Exhaustive Prune method it can be concluded that there exists no significance, so by occasion it can be also used model developed with 6 input variables.

CONCLUSION

In this paper, model for prediction of students' success is developed in order to help professors to identify students that have potential for learning advanced courses and also students who need the additional education in order to improve their knowledge. Using information about students after their first year of studies as input variables, a developed model of multilayer neural network has the ability to predict the success of students at the

end of their studies. Development of such model gives a chance of recognizing which aspects of educational plan and program should be improved in order to induce students to work harder and improve their knowledge in certain scientific branches. This system should also be useful to students, so that they could adopt their learning habits, their work and grades, so that they could achieve the overall success they want.

Future developments and research, firstly in terms of advance use of the concepts EDM, will include integration of a large number of input variables, such as those that are directly related to studies and socio-economic and demographic indicators, their comparative analysis, and secondly in way of model development for predicting study success based on variables that were analyzed in this paper.

REFERENCE

- Minaei-Bidgoli, B. Punch, "Using Genetic Algorithms for Data Mining Optimization in an Educational Web-based System", Genetic and Evolutionary Computation, vol. 2, pp. 2252–2263, 2003.
- Romero, S. Ventura, "Educational data mining: a review of the state-of-the-art", IEEE Trans. Syst. Man Cybernet. C Appl. Rev., 40(6), pp. 601–618, 2011.
- Romero, S. Ventura, P.G. Espejo, C. Hervás, *Educational Data Mining 2008*, The 1st International Conference on Educational Data Mining, 2008.
- C. Romero, S. Ventura, S., "Educational data mining: A survey from 1995 to 2005", Expert Systems with Applications, 33(1), pp. 135-146, 2007.
- H. Guruler, A. Istanbulu, M. Karahasan, "A new student performance analysing system using knowledge discovery in higher educational databases". Computers & Education, 55(1), pp. 247-254. Elsevier Ltd. 2010.
- I.C. Yeh, *Application of artificial neural network model and implementation*. Taiwan: Scholars Books, 1999.
- J. Thomas, M. Hass, *Data Mining in Higher Education : University Student Declaration of Major*, Information Systems, 2011.
- J.M. Gonzalez, S.L. DesJardins, "Artificial neural networks: A new approach to predicting application behaviour", Research in Higher Education, 43(2), pp. 235–258, 2002.
- M. Gerasimovic, L. Stanojevic, U. Bugaric, Z. Miljkovic, A. Veljovic, "Using Artificial Neural Networks for Predictive Modeling of Graduates' Professional Choice", The New Educational Review, 23, pp. 175-188, 2011.
- M. Wook, Y.H. Yahaya, N. Wahab, M.R.M. Isa, N.F. Awang, H.Y. Seong, "Predicting NDUM Student's Academic Performance Using Data Mining Techniques", The Second International Conference on Computer and Electrical Engineering, pp. 357-361, 2009.
- M.H. Falakmasir, J. Habibi, J. (n.d.), "Using Educational Data Mining Methods to Study the Impact of Virtual Classroom in e-Learning", www.educationaldatamining.org, pp. 241-248, 2010. Myller, J. Suhonen, E. Sutinen, "Using Data Mining for Improving Web-Based Course Design", Proc. International Conference on Computers in Education, USA, Washington, pp. 959- 964, 2002.
- P. Schumacher, A. Olinsky, J. Quinn, R. Smith, "A Comparison of Logistic Regression, Neural Networks, and Classification Trees Predicting Success of Actuarial Students", Journal of Education for Business, 85(5), pp. 258-263, 2010.
- R. Stathacopoulou, M. Grigoriadou, M. Samarakou, D. Mitropoulos, "Monitoring students' actions and using teachers' expertise in implementing and evaluating the neural network-based fuzzy diagnostic model", Expert Systems with Applications, 32(4), pp. 955-975, 2007.
- S. Ayesha, T. Mustafa, A.R. Sattar, M.I. Khan, "Data Mining Model for Higher Education System", European Journal of Scientific Research, Vol.43, No.1, pp. 24-29, 2010.
- S. Işljamović, M. Vukićević, M. Suknović, "Demographic influence on students' performance - case study of University of Belgrade", TTEM - Technics Technologies Education Management, 7 (2), pp. 645-666, ISSN 1840-1503, 2012.
- S.H. Liao, C.H. Wen, "Artificial neural networks classification and clustering of methodologies and applications – literature analysis form 1995 to 2005", Expert Systems with Applications, 32(1), pp. 1–11, 2007.
- T. Etchells, A. Nebot, A. Vellido, P.J. Lisboa, F. Mugica, "Learning What is Important: Feature Selection and Rule Extraction in a Virtual Course", in The 14th European Symposium on Artificial Neural Networks, ESANN, Bruges, Belgium, pp. 401–406, 2006.
- T.K. Wu, S.C. Huang, Y.R. Meng, "Evaluation of ANN and SVM classifiers as predictors to the diagnosis of students with learning disabilities", Expert Systems with Applications, 34(3), pp. 1846-1856, 2008.
- V. Kumar, A. Chadha, "An Empirical Study of the Applications of Data Mining Techniques in Higher Education", International Journal of Advanced Computer Science and Application, 2(3), pp. 80-84, 2011.

W.W. Guo, “*Incorporating statistical and neural network approaches for student course satisfaction analysis and prediction*”, *Expert Systems with Applications*, 37(4), pp. 3358-3365, 2010.

METHOD OF PROTECTING EDUCATIONAL CERTIFICATES FROM FORGERY

Nashwan Ahmed AL-MAJMAR
 Department of Math's and Computers, Faculty of Science, Ibb university, Yemen.
 almojammer@yahoo.com

ABSTRACT : Protecting educational certificates from forgery in a modern society is a very important issue. That protection can be provided by using information cryptographic authentication methods based on digital signature schemes. The present paper suggests a system to issue such documents in a way that provide high security and this can be done through using two or more digital signatures based on different and difficult mathematical problems.

Key words: Digital Signature Scheme (DSS), Digital Signature (DS), Information Authentication, Information Verification, Public Key Infrastructure (PKI).

INTRODUCTION

One of the actual and sensitive issues in the modern society is getting illegal certificates and diplomas on education by the people who are not enrolled in universities. This issue is related to the nature of criminal activities structure, performing the forgery of these documents. In this paper we propose a system that uses cryptographic protection methods for issuing and verifying the authenticity of documents, practically the application of this method solves the problem referred to previously and does not require significant costs.

SYSTEM DESCRIPTION

The proposed system can be explained simply on the basis of existence of the used and wide information infrastructure (internet) and the presence of used broadly DS. The proposed method for the validation of diplomas and certificates is based on using a centralized database where reserved digital certificates for documents issued by educational institutions. These digital certificates contain signatures of these educational institution as shown in figure 1.

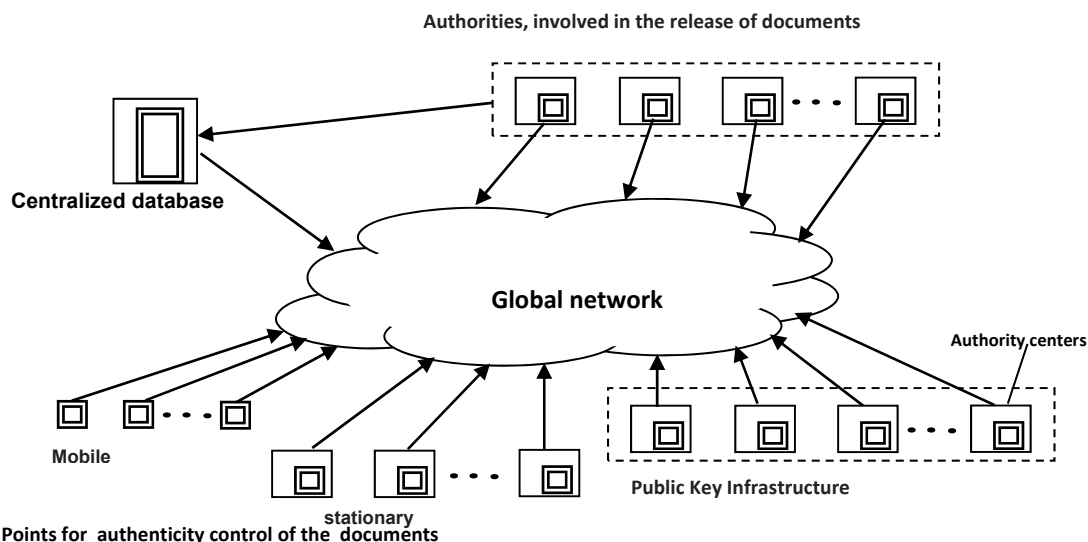

Figure 1. Architecture Of Automated System For Supporting Cryptographic Protection Technology Of The Documents Against Forgery

Each educational document related to digital certificate containing the readable automatically following information:

- First and last name of the student .1
- Name of educational institution .2
- Issuing date of the document .3

Number of document	.4
Specialization	.5
Public key and DS of educational institution	.6

Such documents' issuing system has increased resistance against attacks related to falsifying documents. This resistance linked to using cryptographic protection technology against forgery and applying two DS schemes, based on two different and difficult computational problems i.e. discrete logarithm and factorization. The possibility of applying DSS of the second type is due to the result of development of DS algorithms based on complexity of factorization problem that provide reducing signature's up to 320 bits[1]. Personalized thanks to the small size of DS has the possibility to sign a master image, associated with the document and its content by several different authorities involved in the release of this document. This provides a high security to the system against insiders.

The presence of several authorities, legalizing release of the document, will significantly reduce the probability of participation of the people who are authorized to carry out the legalization of documents, in the process of illegal documents' registration. This is due to a remarkable decrease of the probability that potential internal adversaries will receive simultaneously authority to issue documents. Therefore, in the considered technology requires the presence of two or more digital signatures of controlled message. On the basis of constructing of this system has a technical solution involving the use of a digital signature to bind a specific form of the document with a specific data contained in the document. Thus, we propose the use of paper with stable random microscopic inclusions and the presence of mass production of portable and stationary scanners with sufficient resolution. It also assumes that on the form of document to apply a special mark on which the scanner automatically determines the location of the site is scanned to identify the unique digital image of the form, in which is made an educational certificate document.

The practical impossibility of forgery is linked to the formation of DS to the message, which is formed as an union of a digital image of a particular form with the specific content of the document through the series and number of the document. Taking into consideration the possibility of acceding to such information and biometric information about the owner of the document. As a result, it is possible to verify the authenticity of the document by digital signature, which uses the public key of one, two or more authorities, confirming by its digital signatures the legitimacy issue of this particular instance of the document and its authenticity.

It's supposed to use existing and practically applied PKI for the sake of the distribution of public keys related to the digital legal certificates of the documents on education. Public keys can be obtained from the centralized database via the Internet or from a public key directory distributed by certifying centers. In the case of the developed system obtaining public keys of authorities that certify the authenticity of documents, and checking their authenticity is not a problem, since relying party requires only a few public keys that are valid for quite a long time and are used to verify a large number of documents.

DS is applied to the document in one or two places in a document given that provides a constant presence of the signature in the document. When checking the authenticity of the document, should be scanned the digital image of the document, should be read the information content of this document, form control message and verify the authenticity of a digital signature to this control message. Because that DS physically must be presented on the document, then the crucial issue is to reduce the total size of all DS captured on document in the form of machine-readable tags, this is achieved by using algorithms DS generating signatures with minimal size.

Document's authentication procedure includes:

1. Scanning digital image of document.
2. Formation controlled dataset.
3. Verifying the validity of all signature, using public keys of authorities, confirming the authenticity of the educational certificate.

Modern scanning devices are quite reliable, miniature and reasonably priced, so the proposed technology to protect documents from material counterfeiting is promising for mass application.

GENERATION AND VERIFICATION ALGORITHMS OF DIGITAL SIGNATURES

Persistence of modern DS schemes based on the complexity of solving a difficult computational problem, however, there is a sufficiently small probability that theoretical advances will reduce the security of a digital signature below the critical level. In order to reduce this probability, we have suggested DS schemes, the

disclosure of which requires the simultaneous solution of two or more difficult mathematical problems of various types. In this case, the probability of compromise DS drastically reduced because it is equal to the product of the probabilities of developing more effective ways to solve each of the difficult mathematical problems, such as:

probability (solution of difficult problem of type 1) $\approx 10^{-9}$

probability (solution of difficult problem of type 2) $\approx 10^{-9}$

probability(simultaneous solution of difficult problems of the 1st and 2nd type) $\approx 10^{-18}$

As mentioned earlier regarding automated system for supporting technology of cryptographic protection of documents against forgery is supposed to provide confirmation of the validity of the document by two or more authorities, involved in the issuance of documents. Therefore it's interesting to use two or more different algorithms DS based on various difficult mathematical problems. However, Currently there is a limited number of such problems ,on which can be provided high resistance and relatively small size of DS (320-640 bits).

The simplest solution for diagramming DS, hack which requires the simultaneous solution of two different difficult computational problems is to construct DS schemes, which are based on "mechanical" combination of two different DS schemes, i.e generation of signature as a combination of two independent signatures. This means that a user's digital signature to some document consists of two independent parts, generated by independent algorithms. DS is considered true if each of individual digital signature is genuine. The most interesting mathematical problems for this application are the integer factorization problem of a special type and the discrete logarithm problem in a finite group of large prime order.

3.1. DSS Based On Factorization Problem

As DS scheme, based on the complexity of the factorization problem, it is proposed to use the following scheme represented by the following algorithms of generation and authentication of the digital signature having small size.

Generation Algorithm Of The System Parameters:

- The public key is a pair of numbers n and $y = \alpha^x \text{ mod } n$, where x – is a secret key, n – is a 1024-bit number that $= p * q$ where $|p| = |q| = 512$ -bit .1
- α - is a number referring to simple indicator γ' on modulo p and simultaneous referring to simple indicator γ'' on modulo q , where γ' and γ'' – 80-bit primes. .2
- Generate a random number k , such that $GCD(k, \gamma'\gamma'')=1$ and $1 < k < \gamma'\gamma''$.3

Generation Algorithm Of Signature To The Message M:

- Generate a random number k , such that $gcd(k, \gamma'\gamma'')=1$ and $1 < k < \gamma'\gamma''$, where γ' and γ'' are some 80-bit primes. .1
 - Calculate the value of $r = \alpha^k \text{ mod } n$. .2
 - To the message m joined the number r to form a message $M = m||r$, and compute the hash function of the value M : $E = h(M)$.3
 - Calculate the value of s : $s = k - xE \text{ mod } \gamma'\gamma''$.4
- The public key is (n, y, α) and the digital signature is a pair of numbers (s, E) .

Verification Algorithm Of Signature (S, E):

- Calculate the value of r' : $r' = \alpha^s y^E \text{ mod } n$. .1
- To the message M joined the number r' to form a message $M' = M||r'$, and compute the hash function of the value M' : $E' = H(M')$. .2
- Compare the values E and E' , i.e. if $E = E'$, then the signature is considered genuine. .3

This scheme is based on the complexity of the factorization problem as a basic problem. In fact, the secret key can be calculated by solving the discrete logarithm on modulo n , i.e. solving the equation of calculating the public key $y = \alpha^x \text{ mod } n$, where x – is the unknown quantity. However, the complexity of computing discrete logarithms on composite modulo is not lower complexity of module factorization [1,2].

DSS Based On Discrete Logarithm Problem .3.2

As another type of algorithm, supplementing 1st type algorithms can be used the following scheme of Schnorr C. P. [3].

Generation algorithm of the system parameters:

- primes p, γ , such that $\gamma | (p - 1); |p| \approx 1024, |\gamma| \approx 160$ Choose .1
- q , i.e. $\alpha^\gamma = 1 \pmod p$ an element $\alpha \in \mathbb{Z}_p^*$ of order q Choose .2
- hash function H a cryptographic Choose .3
- such that $1 < x < \gamma x$ number Generate random .4
- Calculate $y = \alpha^{-x} \pmod p$.5
- is (p, γ, α, y) and the public key x , is Private key .6

Generation algorithm of Signature to the message m :

- k such that $1 < k < q$ number Generate a random .1
 - value of $r = \alpha^k \pmod p$ Calculate the .2
 - To the message m joined the number r to form a message $M = m||r$, and compute the hash function of .3
 - the value M : $E = h(M)$
 - $s = k + xE \pmod q$ Calculate the value of s : .4
- the digital signature is a pair of numbers (s, E) .

Verification algorithm of signature (s, E) :

- $R' = \alpha^s y^{-E} \pmod p$ value of r' : Calculate the .1
- To the message m joined the number r' to form a message $M' = m||r'$, and compute the hash function of .2
- the value M' : $E' = h(M')$.
- Performs a comparison of E and E' , if $E = E'$, then the signature is considered genuine. .3

We will show that the system is cryptographic, if the pair $(m, (s, E))$ is a true pair of "message-signature":

$$R' = \alpha^s y^{-E} \pmod p = \alpha^{k+xE} \alpha^{-xE} = \alpha^k = R \pmod p$$

As in the ElGamal scheme [4] the parameter k , acting the role of a one-time secret key must be selected using simple random selection method and used only once.

CONCLUSION

Thus, the suggested system that involves the proposed cryptographic methods, on the basis of their used different DSS makes the forgery of documents impossible. By using this technology, the possibility of criminal groups and elements in their malicious activity are considerably reduced, which in general will favor the rule of law in the society.

REFERENCES

- Berezin A. N., Moldovyan N. A., Shcherbakov V. A. Cryptoschemes Based on Difficulty of Simultaneous Solving Two Different Difficult Problems // Computer Science Journal of Moldova. 2013. V. 21. №. 2(62). P. 280-290. .1
- Menezes, A.J. Handbook of Applied Cryptography [Text] / A.J. Menezes, P.C. Van Oorschot, S.A. Vanstone. – CRC Press, Boca Raton, FL, 1997.- 780 p. .2
- Schnorr, C.P. Efficient signature generation by smart cards [Text] / C.P. Schnorr. – J. Cryptology. – 1991. – V. 4. – P. 161-174. .3
- ElGamal, T. A public key cryptosystem and a signature scheme based on discrete logarithms [Text] / T. ElGamal. – IEEE Transactions on Information Theory. – 1985. – V. IT – 31. – N. 4. – P. 469-472. .4

INFORMING THE PRACTICE OF MATHEMATICS TEACHING IN THE UPPER PRIMARY CLASSES

Masitah SHAHRILL

Sultan Hassanal Bolkiah Institute of Education, Universiti Brunei Darussalam
masitah.shahrill@ubd.edu.bn

Nor Azura HAJI ABDULLAH

Sultan Hassanal Bolkiah Institute of Education, Universiti Brunei Darussalam
azura.abdullah@ubd.edu.bn

Hajah Jamilah HJ MOHD YUSOF

Sultan Hassanal Bolkiah Institute of Education, Universiti Brunei Darussalam
jamilah.yusof@ubd.edu.bn

Hj Ade Shahrin HJ SUHAILI

Sultan Hassanal Bolkiah Institute of Education, Universiti Brunei Darussalam
hjade501@gmail.com

ABSTRACT: In a nationwide study conducted in Brunei Darussalam, a survey was given to 322 Mathematics teachers teaching upper primary classes in all government primary schools. One of the aims of the study was to examine the professional practice of teachers in relation to the teaching of Mathematics including the teachers' understanding of the curriculum and their sense of preparedness in the teaching of primary Mathematics topics. From the findings, 44.3% of teachers recorded a high understanding of the new reformed curriculum goals. However, only 20.2% indicated their degrees of success in the implementation. In relation to the teachers' sense of preparedness, the primary Mathematics teachers rated themselves as well prepared in teaching majority of the topic areas listed under Number and Operations, Measurement, Geometry and Statistics (between 83% to 96%). While the teachers' preparedness to teach Algebra (77.0%) and Mathematical Thinking and Problem Solving (65.2%) were not as encouraging.

Key words: Mathematics Teaching; Upper Primary; Newly Reformed Education Curriculum; Teachers' Preparedness; Brunei Darussalam

INTRODUCTION

The primary years are important in laying the foundations for the development of children's numeracy skills. Students who complete primary schooling with strong numeracy skills are more likely to be successful in secondary school, and to continue on to further education and training so that they acquire the knowledge and skills that will enable them to be productive in the workplace. It has been observed that the abilities to analyse and problem-solve depend on a firm command of the basic enabling skills of literacy and numeracy (Masters, 2009). Numeracy skills are essential to prepare students to meet with the academic demands of schooling, and for future success in the workplace. In addition, numeracy skills are also important for life in the home and community as both print and digital texts play an increasing role in the activities of daily life.

The rationale for the focus on teachers and teaching draws from the fact that teachers play an important role in enabling students to acquire numeracy skills through the implementation of the newly reformed national education curriculum, *Sistem Pendidikan Negara Abad ke-21* (hereafter referred to as SPN21 or the 21st Century National Education System), and the delivery of programmes and other initiatives aimed at improving learning outcomes in Mathematics. Furthermore, the rationale to focus on the upper primary levels of schooling draws from prior research that highlight these levels of schooling as important in terms of the transitions students have to make in terms of curricular demands. Students who fail are at risk of failure in the later years (Croninger et al., 2012). It has been noted that the key to improving learning in primary schools is through improving the quality of classroom teaching (Masters, 2009). Barber and Mourshed (2009) observe that students placed with high performing teachers' progress faster than those placed with low-performing teachers. A major factor in students' learning of numeracy, therefore, is the quality of the teaching of numeracy that they experience in primary school.

The mode of language instruction for the teaching of Mathematics in the lower primary school levels started with the use of Malay Language. It was only in 2008 that Mathematics was then taught in English Language

across all the primary levels in schools in Brunei Darussalam. This study encompassed the entire population of teachers for Mathematics for upper primary classes in government schools in Brunei Darussalam. The national survey was administered in relation to the entire cohort of this teaching force. Respondents were informed that all data obtained would be confidential and anonymity was ensured. The aims of this nationwide study were to:

- ✓ Develop a profile of the contexts of teaching in schools.
- ✓ Examine the professional practice of teachers in relation to the teaching of Mathematics including the use of teaching strategies in the delivery of curriculum specifications for this subject.
- ✓ Profile teachers' professional learning by way of their participation in and need for continuing professional development, as well as teachers' perceptions of changes in their practice.

METHODS

This nationwide survey on teachers and the teaching of Mathematics which was conducted in 2013 focused on the following dimensions: Teacher demographics; Aspects of teaching in relation to the respondent's school; the professional practices of respondents; Practices in relation to the teaching of Mathematics; and Professional development experiences and beliefs of teacher respondents (Shahrill et al., 2014). In this paper, we will only report on the findings comprising of the dimensions in relation to the teacher practices in the teaching of Mathematics that is 'Teacher Knowledge and Preparedness'.

In developing the questionnaire, relevant literature were reviewed (e.g. IAEEA, 2005; 2007; Mullis et al., 1999; OECD, 2009; Poet et al., 2010; Richards et al., 2001; Wray et al., 2013) on the teaching and the professional development of teachers to identify dimensions which would impact students' learning including with regards targeted subject areas. A pilot study was conducted with a sample of 53 upper primary teachers of Mathematics from private primary schools in the nation. The pilot results of the instrument showed that the instrument could be applied in the Bruneian government primary school context and the scales were found to have an acceptable level of reliability which was 0.96 of the Cronbach Alpha. The purpose of the pilot was to examine if the questions actually elicited the intended information for the study and to ensure that the terminology used was understood by each respondent. Suggestions were solicited from the respondents and modifications were made to the questionnaire where several items had to be reworded and mistakes and misinterpretations found were rectified.

For the main study, the questionnaires were administered in 120 government primary schools in all the four districts in Brunei Darussalam to Years 4 to 6 subject teachers of Mathematics (in total 322 teachers). A total number of 310 questionnaires were returned, a 95% return rate in relation to the questionnaires which were distributed. However, only 287 respondents' survey scripts were viably used for further analyses. Codes were developed for questionnaire items for the keying in of data. The quantitative analysis was computed using the IBM SPSS Version 21 software. The basic analysis of the survey data involved frequencies, percentages, and some cross-tabulations. Table 1 below represents the demographics of upper primary teacher respondents.

Table 1. The Demographics for the Upper Primary Mathematics Teachers (N = 287)

Description	Frequency	%	
Gender	Male	49	17.1
	Female	238	82.9
Age	Below 20	2	0.7
	21-30	72	25.1
	31-40	131	45.6
	41-50	56	19.5
	51-60	26	9.1
Highest Qualification*	BC GCE O Level (Year 11 equivalent)	10	3.5
	BC GCE A Level (Year 13 equivalent)	16	5.6
	HNC, NC, NC or Certificates	33	11.5
	HND, ND, OND, or Diplomas	66	23.0
	Bachelor Degree	132	46.0
	Master Degree	28	9.8
Number of years as a Mathematics teacher**	PhD	1	0.3
	0-5	86	30.0
	6-10	105	36.6
	11-15	38	13.2
	16-20	27	9.4
	21-25	10	3.5
	26-30	10	3.5
	31-35	7	2.4
	36 years and above	1	0.3

Note: * One with no response. ** Three with missing responses.

RESULTS

Teaching Mathematics in Upper Primary Classes

In teaching Mathematics in primary classes, teachers may draw from a wide repertoire of practices to develop pedagogical routines and teaching practices in relation to the aspects of mathematical learning stipulated in the national curriculum for Mathematics. Informing the practice of teaching Mathematics in Bruneian upper primary classes are the teacher's understanding of the curriculum, and a sense of preparedness in relation to the teaching of the subject.

Teacher Knowledge of the Curriculum

The national curriculum is realised through the teaching that takes place in schools. Vital to its effective enactment is teachers' understanding of the broad curriculum goals, as well as subject specific aims and objectives. In one of the survey items, the teachers were asked to report on their understanding of the goals of SPN21 and the Mathematics syllabus, as well as their degrees of success in implementing these curriculum frameworks. The results in the Figure 1 below indicated that 44.3% of teachers recorded a high to a very high understanding of the SPN21 goals. However, only 20.2% indicated their degrees of success in implementing the SPN21 goals. Here we also raise questions about factors that may have impeded the effective implementation of the curriculum. The largest proportion of teachers saw themselves as having a moderate understanding of curriculum goals (53.7%) with a similar degree success in putting them into practice (72.5%).

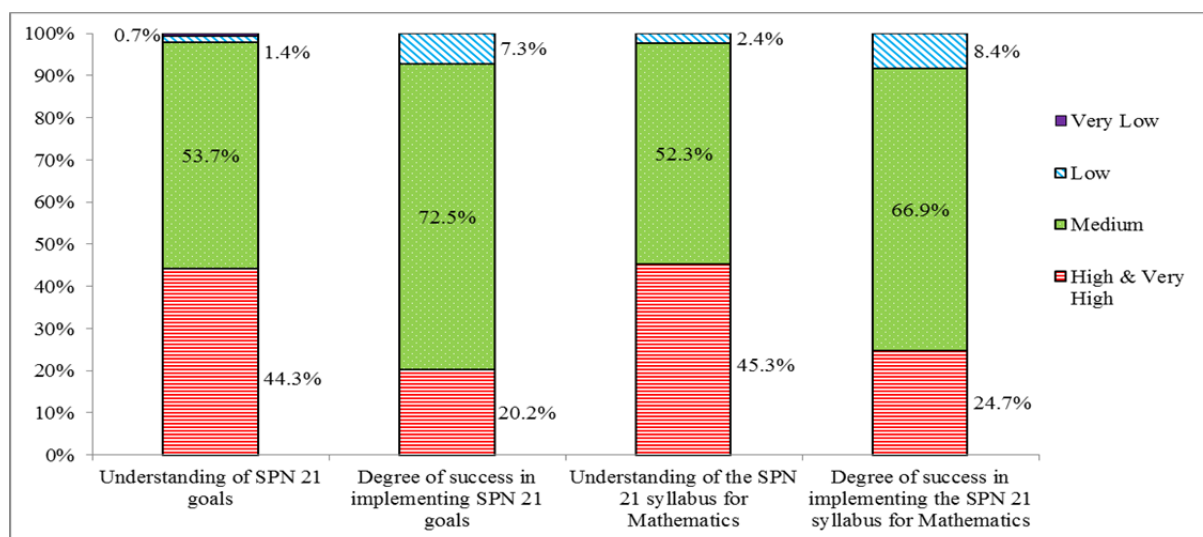

Figure 1. Teachers' Understanding and Perceived Success in Implementing the Curriculum

From Figure 1, the Mathematics primary teachers indicated a relatively higher proportion (45.3%) in understanding the SPN21 syllabus for Mathematics. However, about a quarter (24.7%) of the teacher sample rated themselves as very successfully having implemented the syllabus through their teaching. Just over half of the teacher sample (52.3%) indicated a moderate understanding of the Mathematics syllabus and a much higher sample (66.9%) reported having moderate success in implementing the SPN21 syllabus for Mathematics.

In relation to the findings of the cross tabulations between the number of years as a Mathematics teacher and this survey item overall, we anticipated that many of the beginning teachers (between 0 to 11 years of teaching experience as a Mathematics teacher) would have indicated high or very high understanding of the SPN21 goals or the SPN21 syllabus for Mathematics. However, these were not the case. Many of them reported a medium level of understanding. In contrast, those who had indicated a high to very high proportion in understanding, we anticipated that they will be able to successfully implement the SPN21 goals or the SPN21 syllabus for Mathematics to a higher degree of implementation. Again, these do not appear to be. The number of teachers decreased, across the range of the number of teaching years in regard to the success in implementing.

Preparedness to Teach Mathematics

We also probed teachers' sense of preparedness in relation to teaching the specific topic areas in the primary Mathematics syllabus. There are several areas in relation to the main topics listed, which are Number and

Operations, Measurement, Geometry, Statistics and, Algebra or Pattern and Relation. The results are given below in Table 2. The overall results indicated that the primary Mathematics teachers rated themselves as well prepared and very well prepared in teaching majority of the topic areas listed (between 83% to 96%), with the exception of topic areas in Rates (74.8%), Algebra (77.0%) and Mathematical Thinking and Problem Solving (65.2%).

Table 2. Teachers' Preparedness to Teach the Mathematics Topic Areas

Mathematics topics and sub-topics		Percentage (%)			
		Not prepared at all	Not well prepared	Somewhat prepared	Well prepared & Very well prepared
Number & Operations	Whole Numbers	0.0	0.0	3.1	96.9
	Order of Operations	0.0	0.0	3.5	96.5
	Multiplication and Division	0.0	0.0	8.4	91.6
	Fractions	0.0	0.7	15.4	83.9
	Decimals	0.0	0.7	9.8	89.5
	Percentages	0.0	1.4	15.1	83.5
	Rates	0.7	3.9	20.6	74.8
	Mental Computation	0.0	1.7	15.7	82.6
Measurement	Time	0.0	0.7	10.2	89.1
	Perimeter and Area	0.0	0.0	6.6	93.4
	Length, Mass and Volume	0.0	0.7	7.0	92.3
	Volume and capacity	0.4	0.7	8.9	90.1
	Surface area of solids	0.4	1.4	13.1	85.2
	Volume of solids	0.4	1.1	11.7	86.8
Geometry	Lines and Angles	0.0	0.0	4.2	95.8
	Angles and Triangles	0.0	0.0	4.2	95.8
	Tessellations	0.4	1.4	14.4	83.8
	Quadrilaterals	0.0	0.0	8.4	91.6
	Position and Direction	0.4	0.7	12.1	86.9
	Nets of solids	0.4	0.4	14.2	85.1
Statistics	Collect Data in the Form of Table	0.0	1.0	11.5	87.5
	Read, Interpret, and Draw Simple Bar Graphs and Pictograms	0.0	0.3	10.5	89.2
	Read, Interpret, and Draw Simple Bar Graphs and Pictograms	0.0	0.3	10.5	89.2
	Line Graphs	0.7	1.4	10.6	87.3
	Average	0.7	1.4	12.7	85.2
Algebra / Pattern & Relation	Algebra	1.1	2.1	19.9	77.0
	Mathematical Thinking and Problem Solving	0.3	4.2	30.3	65.2

CONCLUSION AND RECOMMENDATIONS

According to Mullis et al. (1999), teachers' familiarity with the intended curriculum documents can influence the teachers' planning as well as the content delivered and the the kinds of instructional methods to be used. From our findings, the upper primary Mathematics teachers' understanding and their perceived success in implementing the curriculum was not encouraging. This suggests the need for a continuous professional development series if teachers are to realise their full potential as competent practitioners capable of successfully delivering the syllabus. Teachers' understanding of both the national curriculum and the Mathematics syllabus are critical as these documents articulate goals and provide frameworks for practice, which shapes students' learning. Further findings also revealed that the teacher respondents relied heavily on the use of workbooks (96.5%), followed by the category labelled as 'others' (78.2%) and textbooks (67.8%) as the resources used in their Mathematics lessons. These are expected findings because in Mathematics lessons, teachers are dependent on the readily available textbooks and workbooks as their main sources of references or teaching materials. In the 'others' category, majority of the responses given from the submitted questionnaires were worksheets taken from other resources listed such as from other primary mathematics textbooks, the internet and also sourced from own or other teachers' previous collections. Many have also listed the past year examination papers as the resources used by the students in their lessons.

In relation to the teachers' preparedness to teach Algebra (77.0%) and Mathematical Thinking and Problem Solving (65.2%), the results shown are not as promising. This may not be surprising as these topic areas typically involve the mathematical numbers and symbols that students may not be familiar with, although they may often encounter mathematical word problems in their classwork and/or homework exercises, tests or exam questions. Previous findings by local researchers in Brunei Darussalam (Gurung, 2003; Raimah, 2001; Saman, 2000) found that students may be having difficulties in solving word problems because the questions are set in

English. However, there have been contradicting findings that suggested their level of English competency does not influence students' performance in doing mathematics word problems significantly (Pungut & Shahrill, 2014; Yusof, 2003). In addition to that, in these topic areas especially in Mathematical Thinking and Problem Solving, teachers need to have clear understanding of the processes involved in solving non-routine problems. Peker (2009) found that pre-service primary teachers have less anxiety in teaching mathematics when they have conceptual knowledge on problem solving strategies as compared to learning to do problem solving questions using textbook where they read the problem, decide the methods, solve and check their answers. In a different study, one of the suggested effective practices evident from the 20 successful schools surveyed was to implement problem solving with the use of real-life contexts (Ofsted, 2011). Perhaps, teachers may need to explore further to what extent they are willing to make the link of the mathematics taught and to connect real life experiences and the everyday contexts; as well as the application of mathematics for students' future and promoting mathematics as a relevant and interesting subject.

ACKNOWLEDGEMENT

This research was part of a larger project by the Ministry of Education, Brunei Darussalam in collaboration with Sultan Hassanah Bolkhiah Institute of Education, Universiti Brunei Darussalam and Institut Teknologi Brunei.

REFERENCES

- Barber, M., & Mourshed, M. (2007). *How the world's best-performing school systems come out on top*. McKinsey & Co.
- Croninger, R. G., Valli, L., & Chambliss, M. J. (2012). Researching quality in teaching: Enduring and emerging challenges. *Teachers College Record*, 114(4), 1-15.
- Gurung, C. (2003). A comparative study of performance in arithmetic word problems in English language between Bruneian and Ghurkha students. Unpublished M.Ed. Dissertation, Universiti Brunei Darussalam, Brunei Darussalam.
- IAEEA (2005). *Progress in International Reading Literacy Study (PIRLS 2006): Teacher questionnaire*. IEA Publishing.
- IAEEA (2007). *Trends in International Mathematics and Science Study (TIMSS 2007): Teacher questionnaire*. IEA Publishing.
- Masters, G. N. (2009). *A shared challenge: Improving literacy, numeracy and science learning in Queensland primary schools*. Australian Council for Educational Research.
- Mullis, I. V. A., Martin, M. O., Beaton, A. E., Gonzalez, E. J., Kelly, D. L., & Smith, T. A. (1997). *Mathematics achievement in the primary school years: IEA's Third International Mathematics and Science Study (TIMSS)*. IEA Publishing.
- OECD (2009). *Creating effective teaching and learning environments: First results from TALIS*. OECD Publications.
- Ofsted (2011). *Good practice in primary mathematics: Evidence from 20 successful schools*. Manchester, UK: Corwin.
- Peker, M. (2009). The effects of an instruction using Problem Solving strategies in mathematics on the teaching anxiety level of the pre-service primary school teachers. *The New Educational Review*, 119(3-4), 95-114.
- Poet, H., Rudd, P., & Kelly, J. (2010). *Survey of teachers 2010: Support to improve teaching practice*. General Teaching Council for England.
- Pungut, M. H. A., & Shahrill, M. (2014). Students' English Language abilities in solving mathematics word problems. *Mathematics Education Trends and Research* [Online], 1-11. Available: <http://www.ispacs.com/journals/metr/2014/metr-00048/>
- Raimah, M. (2001). An investigation of errors made by primary six pupils on word problems involving fractions. Unpublished M.Ed. Dissertation, Universiti Brunei Darussalam, Brunei Darussalam.
- Richards, J. C., Gallo, P. B., & Renandya, W. A. (2001). Exploring teachers' beliefs and the processes of change. *PAC Journal*, 1.1, 41-58.
- Saman, A. (2000). Investigating understanding by primary six pupils of word problems involving multiplication and division. Unpublished M.Ed. Dissertation, Universiti Brunei Darussalam, Brunei Darussalam.
- Shahrill, M., Abdullah, N. A., & Yusof, J. (2014). *Teachers and Teaching of Mathematics in Primary Schools in Brunei Darussalam*. Ministry of Education, Brunei Darussalam.
- Wray, D., Medwell, J., Poulson, L., & Fox, R. (2013). *Teaching literacy effectively in the primary school*. London: Routledge.
- Yusof, J. (2003). *Mathematical errors in fractions word: A longitudinal study of primary level pupils in Brunei*. Unpublished Ph.D. Thesis, Curtin University of Technology, Perth, Australia.

ASSESSING TEACHER'S PERFORMANCE IN THE LIGHT USING TECHNOLOGICAL TOOLS IN TEACHING AND ITS RELATIONSHIP TO THE STUDENT'S PERFORMANCE AND THEIR ATTITUDES TOWARD MATHEMATICS EDUCATION

Dr. Othman Ali ALGHTANI
Assistant professor of teaching mathematics, University of Tabuk
othman1435@yahoo.com

ABSTRACT: The main aim of this research was assessing Teacher's Performance in the light using Technological tools in teaching mathematics. To achieve this aim, literature and previous studies were analyzed to characterize the variables of the study, and building the tools of this search, that identified with the four dimensions: (Technological tools support the educational environment in a mathematics class- Technological tools in teaching plan and applying- evaluating the performance of students – reflective teaching and professional development for teachers of mathematics). also , the mathematics test and scale to assess the student's performance and their attitudes toward mathematics Education.

The research was based on descriptive analytical method, the sample consisted of (30) teachers of mathematics in primary school and their students (n=480) from Tabuk city schools, and after field Applying procedures, the main finding was 60% of math teachers have not perspective to use the technological in supporting educational environment in a mathematics class the technological tools to encourage the learner to interact positively, and using technological tools in the planning and implementation of teaching, evaluating the performance of the students, and employ them in order to self-professional development for teachers of mathematics. also There is a direct correlation between the use of positive mathematics teachers for the technological tools and the development of students' performance and positive attitudes towards mathematics. The recommendations of study are building training programs to employ technological tools in support of learning environment school mathematics and improve their performance teaching through the development of positive attitudes towards their relevance and effectiveness in mathematics.

Keywords: teaching mathematics, Teacher's Performance.

INTRODUCTION

Kingdom of Saudi Arabia developed the curriculum in the light of both national and international standards . The main aims were: developing how the students build the knowledge, developing thinking process, and improving the smart behavior of the students. The educational system tried to solve a lot of problems that relate to the vision, mission, and the aims of learning. also the curriculum of mathematics education depends on using the technological tools in mathematics education. It is very necessary to apply the technological tools in math classes

On the other hand, in the last 20 years, a lot of researches presented the main ideas about using technological tools. it is related to developing mathematical concepts, mastering mathematical skills, and discovering many mathematical generalizations. (Hartsell , et.al, 2009). It is considered to be very essential for the students in the 21st century. technological tools is educational frameworks that helps in improving the mathematics education aims. it encourage the students, and math teachers through communicating using alternative ways. (Beyerbach, Walsh, 2001).

A lot of finding of studies refer to using technological tools in mathematics class improve student's performance in mathematics , for example solving problem skills, and word problem solving. it helps the students to make mathematics representations. Also, the to using technological tools develop their attitudes toward mathematics Education (Naida, 2003).

A good starting point when using technological tools into a school is introducing the technological tools to teachers mathematics. The experience will be more effective for students if teachers develop a deep understanding and appreciation of using technological tools before they present them to the students in class.

They may have numerous initial questions, for examples: What do these using technological tools in mathematics classes? , How will the teachers work with the students to develop mathematical knowledge using technological tools?, How can the teachers put the model into practice? And What is the role of the teachers in using technological tools?(**Yildirim, 2000**).

In addition, classroom environment plays the main role in achieving the objectives. It provides many opportunities to influence behavior, cognitive behavior, learning, and growth (**Friedman, 1999**). about using technological tools on the classroom environment providing the students with a good learning environment and developing the math objectives. (**Norton, et.al, 2000**)

Finally, Developing and assessing the mathematics education aims are the main tasks of the teachers. For that reason, a lot of researchers have been investigating the teaching procedures in order to develop them. It is very important to be able to observe the teachers and encourage them to be reflective and help them improve their performance in math class.

Research questions: This research investigates the following question:

- To what extent mathematics teachers master using technological tools in certain fields of the teaching and learning process; i.e. (teaching plan, building the knowledge, group management, assessment, and extra activities)?
- what the relationship between Teacher's Performance in the light using Technological tools and the student's performance and their attitudes toward mathematics Education?

METHODS

Instrumentation : To achieve the aims of this research two Instruments were used. To assess the teaching performance , questionnaire was prepared. It is related to the assessment of the teaching performance of learning habits of mind. It included 5 dimensions of teaching: (teaching plan, building the knowledge , groups management, assessment , extra activities) also the questionnaire was prepared to assess the students attitude.

Search sample: The sample of this search was selected from the original community at Tabuk city. it included 30 mathematics teachers and thire students (480) from primary, prep., scoubdary schools.

The instrument were applied by the researcher and mathematics supervioser at the school. they help the teachers tthrough applying the atitude scale . the researchers met the teachers to apply the questionnaire that related to measuring the atitude. The meeting with the teachers was meant to discuss and interpret a lot of question about the terms and concepts that were included in the questionnaire. Through that open discussion, we noticed that there were a lot of generalizations, and that most of the teachers did not have enough experience regarding the concepts .

RESULTS AND FINDINGS

To answer the first question: **extent mathematics teachers master using technological tools in certain fields of the teaching and learning process; i.e. (teaching plan, building the knowledge, group management, assessment, and extra activities)?**

Through using SPSS, the frequency, percentage and the mean were calculated. The results are clearly stated in the following table:

Table (1) The Frequency, Percentage And The Mean Of Using Technological Tools indicators

Teaching Performance	Distribution								The mean
	Exemplary (4)		Accomplished (3)		Developing (2)		Beginning (1)		
	frequency	Percent %	frequency	Percent %	frequency	Percent %	frequency	Percent %	

Using technological tools as a framework of teaching	2	6,6	6	20	10	31,7	12	40	1,97
Write the aims of the lesson in relation technological tools	2	6,6	5	16,7	9	30	14	46,7	1,73
Using technological tools to building mathematical knowledge	2	6,6	6	20	12	40	10	33,4	1,95
Design the cooperative learning activities	4	13,3	8	26,7	8	26,7	10	33,3	2,52
dependen on Using technological tools	5	16,7	9	30	8	26,7	8	26,7	2,38
Organize the content gradually									
Connect between conceptual and procedural knowledge using Using technological tools	8	26,6	16	53,5	5	16,7	1	3,3	3,07
Use the technological tools in problem solving strategies	4	13,3	6	20	10	33,3	10	33,3	2,13
Encourage the discussion among the students	3	10	7	28,3	12	40	8	26,7	2,15
Use of appropriate equipment in class	2	6,7	13	43,3	9	30	6	20	2,37
Use the technological tools to enhance the students in developing math thinking	3	10	6	20	9	30	12	40	1,98
create a class environment Using technological tools is main part in work	1	3,3	8	26,6	16	53,3	5	16,7	2,15
Encourage students to use the environmental tools	2	6,7	10	33,3	12	40	6	20	2,27
Connect between family and school to enhance students using technological tools	1	3,3	3	10	20	66,6	6	20	2,02
Use the technological tools to communicate with students with homework activities	6	20	16	53,3	9	30	0	0	3,03
Use the technological tools in developing thinking	8	13,3	14	23,3	30	50	8	13,3	2,37
Design the different activities, for examples: search, use library, math site, ...e-mail, facebook,..	4	6,7	13	21,6	25	41,6	18	30	2,05
The mean of total									2,26

Through the table (1) we can observe that the mean total of the checklist is (2.26). It is less than the mastering value (≥ 3.2). Also, the mean of all of the items are less than the mastering value. Through the observation, the researchers noticed that most of the teachers of the sample do not have clear perspective of using the technological tools of teaching mathematics. In addition, the range of means of the teaching indicators is (1.73 and 3.07). Most of the indicators are not close to the mastering value (3.2). There are, however, some indicators which are close to the mastering value, for example: Connect between conceptual and procedural knowledge using technological tools (3.07), Use the technological tools to communicate with students with homework activities (3.03), Use the technological tools to communicate with students with homework activities (3.03). Help the students to apply the pervious experiences (3.02). Most of the pervious indicators refer to general teaching procedures, and did not relate directly to using technological tools.

On the other hand, there are a lot of indicators that refer to a weakness in using technological tools for most of the sample. Most of those indicators are mainly related to the procedures for using technological tools, for example: Write the aims of the lesson in relation technological tools (1.73), Using technological tools to building mathematical knowledge (1.95), Using technological tools as a framework of teaching (1.97), Use the technological tools to enhance the students in developing math thinking (1.98). Finally, the researchers deduce that Most of the teachers did not master the indicators of Using technological tools as a part of teaching performance that relate to: (teaching plan, , building the knowledge, groups management, assessment, extra activities).

To answer the second question: what the relationship between Teacher's Performance in the light using Technological tools and the student's performance and their attitudes toward mathematics Education? Through using SPSS, the frequency, percentage and the mean were calculated. The results are detailed in the following table:

Table(2): The Frequency , Percentage And The Mean Of The Indicators Of 16 Habits Of Mind

	Accomplish ed		Developing		Beginning		Beginning		
	frequency	Percent %	frequency	Percent %	frequency	Percent %	frequency	Percent %	
I like the mathematics class	18	5	167	46.7	113	31.7	10	16.7	2.4
I attend in math class daily	24	6.7	71	20	157	43.3	18	30	2.03
I communctewith my teacher mathematicaly	30	8.3	83	23.3	211	58.3	6	10	2.3
Mathematics is fascinating and fun.	36	10	115	31.6	127	35	14	23.3	2.18
The feeling that I have toward mathematics is a good feeling.	30	8.3	66	18.3	117	31.7	25	41.7	1.93
Mathematics is something which I enjoy a great deal.	36	10	90	25	174	48.3	10	16.7	2.28
I help my partener to show their perspective in thinking.	30	8.3	54	15	89	25	157	51.7	1.8
Help the students to understand what the others say.	42	11.7	114	31.7	114	31.7	60	25	2.3
Ask the partener to explain they thoughts to understand mathematics concepts	36	10	168	46.3	113	31.7	43	11.7	2.55
Mathematics is a course in school which I have always enjoyed studying	24	6.7	102	28.3	169	46.7	65	18.3	2.23
I uasaully do my homework of mathematics	48	13.3	102	45	119	33.3	31	8.3	2.63
Mathematics topices are not relatetded to my life.	24	6.7	54	15	96	26.7	186	51.7	1.93
I ask my teacher when faced with a task, a problem, or a question.	23	6.7	96	26.7	209	58.3	31	8.3	2.32
I like mathematics clases include the situation that makes make me enthusiastic.	73	20	126	35	137	38.3	25	6.7	2.35
I use the pervious knowledge in solving the problems related to the situation.	107	30	168	46.3	102	23.3	0	0	3.07
I work mathematicaly with enhancement activities continuous learning.	67	18.3	192	53.3	89	25	13	3.3	2.87
I Consider the learning interests in mathematics class.	35	10	149	41.7	121	33.3	54	15	2.47
I make connection between family and school	37	10	83	23.3	109	30	22	36.7	2.07
Total									2,32

Through table (2) we can deduce that the mean total of the questionnaire is (2.32). It is less than the mastering value (≥ 3.2) . All the means' of all items are less than (≤ 3.07) and more than (≥ 1.8) . Through the observation, the researchers observed that most of the students of the sample do not have clear perspective about the mathematics education, its related to thire life . they also do not have general perspective in developing thire performance buy using technological tools.

CONCLUSION

Using Technological tools is a main part in teaching mathematics. Through the results of this research , most of the teachers did not have clear and deep perspective about using Technological tools in teaching mathematics in general and its dimensions (teaching plan, building the knowledge, groups management, assessment, and extra activities). Most of them did not write lessons aims that are relative to using Technological tools, did not organize classes, did not design strategies that encourage the students to using Technological tools in mathematics representation. They, also, did not assess thire teaching performance in the light of using Technological tools . also , most of the teachers did not have clear and deep perspective of habits of mind in general as well as in detail . They did not have enough experiences that relate to the terms of habits of mind and how to develop them. also there are positive relationship between using Technological tools in teaching mathematics, and students performance and thire atitude toward mathematics.

RECOMMENDATIONS

Finally, The study found a set of recommendations the most important building training programs procedural to employ innovations of technology in support of learning environment school mathematics and improve their performance teaching through the development of positive attitudes towards their relevance and effectiveness in mathematics.

REFERENCES

- Beyerbach, B., Walsh, C., Vannatta, R.** (2001).From teaching technology to using technology to enhance student learning: Preservice teachers' changing perceptions of technology infusion. *Journal of Technology and Teacher Education*, 9(1).105-27.
- Friedman ,M.**(1999). NCTM Member Handbook, *National Council of teacher of Mathematics* &Hawaii Department of education-School(online).
- Deborah,L.& Lisa.D.**(2000). Integrating Computer Technology Into Classroom .*Educational Technology* ,51(3).9-18.
- Naida,som.**(2003). Trends in Faculty use and perceptions of learning .*learning &teaching in action*.2(3).
- Norton, S., McRobbie C. J., & Cooper, T. J.** (2000).Exploring secondary mathematics teachers' reasons for not using computers in their teaching: five case studies. *Journal of Research on Computing in Education*, 33(1). 87-110
- Yildirim, S.**(2000). Effects of an educational computing course on preservice and in-service teachers: A discussion and analysis of attitudes and use. *Journal of Research on Computing in Education*, 32(4). 479-495.
- Hartsell, T., Herron, S., Fang, H., & Rathod, A.**(2009). Effectiveness of professional development in teaching mathematics and technology applications. *Journal of Educational Technology Development and Exchange*, 2(1). 53-

ŞİFRELEME ETKİNLİĞİNİN MATEMATİK DERSLERİNDE KULLANIMINA BİR ÖRNEK

AN EXAMPLE OF USING ENCRYPTION ACTIVITY IN MATHEMATICS CLASSES

Ahmet Şükrü ÖZDEMİR
Marmara Üniversitesi
ahmet.ozdemir@marmara.edu.tr

Sevda GÖKTEPE
Yıldız Teknik Üniversitesi
goktepe@yildiz.edu.tr

ÖZET: Son yıllarda matematik eğitiminde çeşitli şifreleme teknikleri kullanılarak yapılan etkinliklere rastlanmaktadır. Çalışmanın amacı araştırmacılara ve öğretmenlere matematik derslerinde kullanılabilecek bir şifreleme etkinliği örneği sunmaktır. Bu doğrultuda araştırmacılar tarafından “modern şifreleme” adı ile bir çalışma yapıldı ve oluşturularak iki ders boyunca etkinlik gerçekleştirilmiştir. Çalışmaya bir devlet okulunda eğitim-öğretim görmekte olan 36 altıncı sınıf öğrencisi katılmıştır. Uygulamalar sırasında her öğrenciye çalışma kâğıdı dağıtılmış, öğrenciler bireysel olarak çalışmışlardır. Bu etkinlik üç adımdan oluşmaktadır ve her bir aşamada istenilenler bir önceki aşama ile bağlantılıdır. Etkinlikteki adımlar sırasıyla öğretmen rehberliğiyle gerçekleştirilmiştir. Şifreleme etkinliği öteleme işlemi temel almaktadır. Her bir adım bir sonraki ile ilişkili olduğundan doğru şifreye ulaşabilmek için tüm adımlar hatasız bir şekilde tamamlanmalıdır. Bu da öğrencilerin dikkatli olmasını ve odaklanmasını gerektirmektedir. Nitekim etkinlik sonunda sadece beş öğrenci doğru şifreye ulaşmıştır. Matematik derslerinde eğitim-öğretim sürecinde şifreleme etkinliklerinin kullanılması öğrencilerin ilgisini çekmektedir. Dolayısıyla böyle etkinlikler öğrencilerin matematik dersine dikkatlerini çekmede ve motivasyonlarını arttırmada bir araç olarak kullanılabilir.

Anahtar sözcükler: şifreleme etkinliği, matematik eğitimi, öteleme

ABSTRACT: In recent years, there are various encryption activities which are used in mathematics lessons. The aim of the study is to present an example which can be used in mathematics classes for teachers and researchers. For this purpose a worksheet was named “ modern encryption” was prepared by researchers. This activity was carried out during two lesson time. 36 sixth grade students attended to study from a public university. The worksheet was handed out to each student and they worked individually. This activity consisted of three steps and operations in each step were associated with the previous step. The steps in the activity were performed by teacher guidance respectively. The encryption activity was based on translation process. Using of encryption in teaching-learning process has attracted the attention of students. Thus, such activities draw students' attention to mathematics and can be used as a tool to increase their motivation.

Key words: encryption activities, mathematics education, translation

GİRİŞ

Schneider (1996) kriptolojinin Yunanca krypto's (saklı) ve lo'gos (kelime) kelimelerinin birleştirilmesinden oluşturulduğunu ifade etmiştir (akt: Yerlikaya, 2006). Kriptoloji, şifreleme çalışmalarından meydana gelmektedir (Güler, 2007).

Son yıllarda matematik eğitiminde çeşitli şifreleme teknikleri kullanılarak yapılan etkinliklere rastlanmaktadır (Myerscough ve diğerleri, 1996; Özdemir ve Yıldız, 2012; Katrancı ve Özdemir, 2013; Bahadır ve Özdemir, 2012; Güler, 2007). Myerscough ve arkadaşlarının çalışmasının sonuçlarına göre bazı öğrenciler şifreyi çözmeye zorlanmış, bazıları öğretmen ipucu vermeden şifre hakkında yorum yapmamış fakat birçoğunun şifreyi çözmeye inatçı ve başarılı oldukları tespit edilmiştir (akt: Güler, 2007). Güler (2007) yaptığı çalışmada modüler aritmetik konusunun öğretiminde şifreleme etkinliklerinin kullanılmasının öğrenci tutumu ve başarısına etkisini incelemiştir. Araştırmada ön test – son test kontrol gruplu desen kullanılmış ve deney grubu öğrencilerine modüler aritmetik konusunun öğretiminde şifreleme etkinliklerine yer verilirken, kontrol grubu öğrencilerine ise geleneksel öğretim yöntemi kullanılarak dersler işlenmiştir. Araştırma sonucunda deney grubu öğrencilerin

akademik başarıları kontrol grubu öğrencilerine göre anlamlı düzeyde yüksek çıkmıştır. Deney grubu öğrencilerinin şifreleme etkinliklerine yönelik tutumlarının ise olumlu olduğu belirlenmiştir. Özdemir ve Yıldız (2012) barkodlarla ilgili bir şifreleme etkinliğinin uygulanabilirliğinin incelenmesi ve öğrencilerin etkinliklere ilgili görüşleri başlıklı çalışmalarında 11 adet sekizinci sınıf öğrencisi ile çalışmışlardır. Araştırma sonucunda, kullanılan etkinliğin ilköğretim 8. sınıf düzeyi için uygun ve kullanılabilir olduğu sonucuna ulaşılmıştır. Ayrıca öğrencilerin etkinlikle ilgili görüşlerinin olumlu yönde olduğu görülmüştür. Bahadır ve Özdemir (2012) çalışmalarında “yer değiştirme şifrelemesi” isimli şifreleme tekniği ile ilgili bir şifreleme etkinliğinin 7. sınıf matematik dersindeki permütasyon ve olasılık konu-sununun işlenmesi sırasında uygulanabilirliğini incelemiş ve bu etkinlikle ilgili öğrencilerin görüşlerini incelemiştir. Benzer şekilde kullanılan etkinliğin ilköğretim 7. sınıf düzeyi için uygun ve kullanılabilir olduğu sonucuna ulaşılmıştır ve öğrencilerin şifreleme etkinliği ile ilgili görüşleri olumlu yöndedir. Katrancı ve Özdemir (2013) araştırmalarında RSA şifreleme yöntemini kullanarak, öğrencilerin modüler aritmetik konusunu pekiştirmelerini amaçlamıştır. RSA şifrelemesi yöntemine göre hazırlanan etkinlikler bir devlet okulunda öğrenim görmekte olan 19 adet on birinci sınıf öğrencisiyle iki ders saati boyunca gerçekleştirilmiştir. Günlük hayatta pek çok şifre ile karşılaşan öğrencilerin değişik bir yöntem öğrenmenin hazzını yaşadıkları gözlenmiş, modüler aritmetik konusunda zorlandıkları noktaları aştıkları, eksik oldukları noktaları tamamladıkları sonuçlarına ulaşılmıştır.

Bu çalışmada “Mathematics Enhancement Programme” programının önerdiği “modern şifreleme” etkinliği kullanılmıştır. Matematik derslerinde kullanılacak bir şifreleme etkinliği örnek olarak sunulmuş ve bu etkinliğin değerlendirilmesi yapılmıştır.

YÖNTEM

Çalışmada doküman analizi yapılmıştır. Yapılacak olan çalışma ile ilgili mevcut kayıt ve belgelerin toplanıp incelenmesine doküman analizi denir. Bu süreçte araştırmacı kaynaklardaki bilgileri alır ve araştırması için kullanır (Çepni, 2009). Genel literatür taraması olarak da ifade edilmektedir. Bu çalışmada matematik eğitiminde şifreleme etkinliklerinin yeri araştırılmış ve bir örnek sunulmuştur. Şifreleme etkinliği üç adımdan oluşmaktadır ve her bir aşamada istenilenler bir önceki aşama ile ilişkilidir. Etkinlikteki adımlar sırasıyla öğretmen rehberliğiyle gerçekleştirilmiştir. Şifreleme etkinliği öteleme işlemi temel almaktadır. Doğru şifreye ulaşabilmek için tüm adımlar hatasız bir şekilde tamamlanmalıdır. Etkinlik bireysel olarak tamamlandıktan sonra şifreye ulaşım durumları, her bir adımın ayrı ayrı değerlendirmesi yapılmış ve toplam 36 öğrenci için genel değerlendirme puanı hesaplanmıştır. Araştırmanın çalışma grubunu bir devlet okulunda öğrenim gören 36 adet altıncı sınıf öğrencisi oluşturmaktadır. Etkinlik 2 ders saati süresince gerçekleştirilmiştir.

Uygulama Süreci

Araştırmada kullanılan etkinlik, “modern şifreleme” şeklinde isimlendirilen bir şifreleme etkinliği ile ilgilidir. İlk olarak öğrencilere uygulama süresince yapılacaklardan bahsedilmiştir. Daha sonra bireysel olarak çalışma kağıdındaki soruları çözmeleri istenmiştir. Çalışma yaprağında yer alan sorular aşağıdaki gibidir:

Çalışma Yaprağı

Modern şifreleme isimli bu etkinlik 3 adımdan oluşan bir şifreleme etkinliğidir. Her bir aşamada istenilenleri bir önceki aşama ile bağlantılı bir şekilde yapmaya dikkat ediniz.

Aşağıdaki adımları izleyerek modern şifreleme yoluyla “MATEMATİK SEVGİSİ” metnini şifreleyiniz.

Adım 1: Değişken değiştirme

Bu adımda öncelikle harfler sütunlara yerleştirilir. Sonra 3 birimlik öteleme ile yani aşağıda tabloda verildiği gibi harfler ötelenerek şifreleme yapılır.

A	B	C	Ç	D	E	F	G	Ğ	H	I	İ	J	K	L	M
Ç	D	E	F	G	Ğ	H	I	İ	J	K	L	M	N	O	Ö
N	O	Ö	P	R	S	Ş	T	U	Ü	V	Y	Z	.	,	?
P	R	S	Ş	T	U	Ü	V	Y	Z	.	,	?	A	B	C

İlk sütun aşağıdaki gibi doldurulmuştur. Benzer şekilde diğer sütunlara da harfleri yerleştirerek öteleme işlemini yapınız.

M			
A			
T			
E			

→

Adım 2: Satır değiştirme

			←
	←		
←			

Yandaki gibi satırların kendi içinde öteleme yapılır. İlk satırda hiçbir değişiklik yapılmaz. İkinci satırdaki her bir harf sola doğru 1 birim yer değiştirir. Üçüncü satırdakiler 2 birim, son satırdakiler 3 birim sola ilerlerler.

1. adım sonunda elde ettiğiniz tabloya 2. adımdaki satır değiştirme işlemini yapınız.

Adım 3: Sütun dönüşümü

Her bir sütun için aşağıdaki örnekteki gibi bir dönüşüm yapılır.

A	→	B+C+D
B		A+C+D
C		A+B+D
D		A+B+C

Toplama işlemi yapılırken ikili sisteme uygun olarak şu yol izlenir:

$0 + 0 = 0$	$0 + 1 = 1$
$1 + 0 = 1$	$1 + 1 = 0$

Her bir harfe karşılık gelen beş basamaklı sayılar şunlardır:

Harf	Sayı	Harf	Sayı	Harf	Sayı	Harf	Sayı
A	00000	Ğ	01000	N	10000	U	11000
B	00001	H	01001	O	10001	Ü	11001
C	00010	I	01010	Ö	10010	V	11010
Ç	00011	İ	01011	P	10011	Y	11011
D	00100	J	01100	R	10100	Z	11100
E	00101	K	01101	S	10101	.	11101
F	00110	L	01110	Ş	10110	,	11110
G	00111	M	01111	T	10111	?	11111

Etkinlik gerçekleştirildikten sonra çalışma yaprağında yer alan her bir adım için puan verilerek her bir öğrenci için bir değerlendirme puanı elde edilmiştir. Bu puanlara ait ortalama, standart sapma değerleri bulunarak betimsel istatistik değerleri hesaplanmıştır.

Çalışma yaprağında yer alan her bir adım ve şifreye ulaşma durumu olmak üzere toplam dört aşamada değerlendirme yapılmıştır. Adımların değerlendirilmesi için “rubrik” hazırlanmış ve sonra da genel bir değerlendirme yapılmıştır. Değerlendirme şu şekilde gerçekleştirilmiştir.

“MATEMATİK SEVGİSİ” metninin ilk tablonun sütunlarına yerleştirilmesi	İlk tabloyu kullanarak öteleme yapılması	1. adım sonunda elde edilen matrisin yerleştirilmesi	Satır değiştirme işleminin yapılması	Sütunların yerleştirilmesi	Toplamların yazılması	İkili sisteme uygun işlemlerin yapılması	Toplam Puan	Şifreye Ulaşma
1 puan	1 puan	1 puan	1 puan	1 puan	1 puan	1 puan		

Her bir durumun doğru gerçekleştirilmesi durumunda 1 puan verilecektir. Örneğin hem “MATEMATİK SEVGİSİ” metnini ilk tablonun sütunlarına doğru yerleştiren hem de ilk tabloyu kullanarak doğru öteleme yapan kişi bu adım için 2 puan alırken herhangi birini yapan kişi 1 puan alacaktır.

Son olarak şifreye doğru bir şekilde ulaşım durumu değerlendirilmiştir. Şifreye doğru ya da yanlış bir şekilde ulaşımla değerlendirme yapılmıştır.

BULGULAR

Verilerin analizinde öğrencilere dağıtılan çalışma yaprakları incelenmiştir. Çalışma yaprağında yer alan sorular yukarıda belirtildiği şekilde değerlendirilerek her bir öğrenci için elde edilen genel değerlendirme puanlarına ait ortalama, standart sapma değerleri aşağıdaki gibidir:

Tablo 1. Şifreleme etkinliğinin değerlendirilmesi

	N	Ortalama	Mak.	Min.	Standart Sapma
Genel Değerlendirme Puanı	36	3,9	7	2	1,96

Doğru şifreye ulaşan kişiler 7 puan almıştır. Dolayısıyla şifreleme etkinliğinden alınacak maksimum puan 7 dir. Şifreye ulaşma durumlarına bakıldığında ise 36 öğrenciden sadece 5'i doğru şifreye ulaşırken, 31'i yanlış bir şifreye ulaşmış ya da herhangi bir şifreye ulaşamamıştır. Sonuç olarak sınıfın yaklaşık % 86'sı doğru şifreye ulaşamamıştır.

Her bir öğrencinin çalışma kağıdı incelendiğinde öğrencilerin en az puan aldığı kısım 3. adımdır. Üçüncü adımda sütundaki her bir elemanın dönüşümü yapılacaktır. Bu aşamada öğrencilerin alışık olduklarından farklı bir toplama işlemi vardır. Ve elde edilen sayılara karşılık bir harf bulunur ve şifre çözülür.

SONUÇ VE ÖNERİLER

Bu çalışmada matematik derslerinde kullanılacak bir şifreleme etkinliği örnek olarak sunulmuştur. Etkinlik birbirini takip eden üç adımdan oluşmaktadır. Etkinlikte kullanılan çalışma yaprağı yukarıda tanıtılmaktadır. Öğrencilerin en düşük puanı 3. adımda almalarının sebebi bu adımın kendi içinde birden fazla aşama içermesidir ve öğrencilere daha karmaşık gelmiş olabilir. Doğru şifreye ulaşabilmek için bütün adımları hatasız sürdürmek gerektiğinden etkinliğe iyi odaklanılması ve işlem hatası yapılmaması gerekmektedir.

Ayrıca dersin dikkati çekme, derse geçiş aşamalarında şifreleme etkinlikleri kullanılabilir. Ders kitaplarında uygun konularda şifreleme etkinliklerine yer verilebilir. Şifreleme kullanılarak yapılan bu etkinlik örnekleri beşinci ve altıncı sınıf düzeyinde “matematik uygulamaları” dersinde etkili araçlar olarak kullanılabilir. Derste

şifreleme etkinlikleri öğretmen tarafından verildikten sonra öğrencilerden de çeşitli şifreler üretmeleri ve ürettikleri şifreleri deşifre etmeleri istenebilir.

KAYNAKLAR

- Bahadır, E. ve Özdemir, A. Ş. (2012). Yer deęiřtirme şifreleme etkinlięinin uygulanabilirlięinin incelenmesi ve öğrencilerin etkinlikle ilgili görüşleri. *KALEM Uluslararası Eğitim ve İnsan Bilimleri Dergisi*, 2(2), 51-90.
- Çepni, S. (2009). Arařtırma ve Proje Çalışmalarına Giriş (Geliřtirilmiş 4. Baskı). Trabzon: Yazarın kendisi.
- Güler, E. (2007). *Modüler aritmetik konusunun öğretiminde şifreleme aktivitelerinin matematik başarısına etkisi*. Yayınlanmamış yüksek lisans tezi, Marmara Üniversitesi Eğitim Bilimleri Enstitüsü.
- Katranç, Y. ve Özdemir, A. Ş. (2012). RSA şifreleme yardımıyla modüler aritmetik konusunun pekiřtirilmesi. *KALEM Uluslararası Eğitim ve İnsan Bilimleri Dergisi*, 3(1), 149-186.
- Özdemir, A. Ş. ve Yıldız, Z. (2012). Barkodlarla ilgili bir şifreleme etkinlięinin uygulanabilirlięinin incelenmesi ve öğrencilerin etkinlikle ilgili görüşleri. *Çankırı Karatekin Üniversitesi Sosyal Bilimler Enstitüsü Dergisi*, 2(2), 61-78.
- Yerlikaya, T. (2006). *Yeni şifreleme algoritmalarının analizi*. Yayınlanmamış doktora tezi, Trakya Üniversitesi, Fen Bilimleri Enstitüsü.

EFFECTS OF PARENTAL ROLES IN STUDENTS' MATHEMATICAL LEARNING: HOW DOES THE EDUCATION LEVEL OF PARENTS EFFECT THEIR INVOLVEMENT?

Şule ŞAHİN DOĞRUER
Şükufe Nihal Ortaokulu
sule_sahinn@hotmail.com

ABSTRACT: The purpose of this is qualitative study was to explain the parents' (specifically mothers' in this study) own experiences with mathematics, and how these practices affected beliefs and motivation about mathematics, their roles in involvement of their children's mathematics learning process. While explaining the phenomenon, the expectancy value and attribution theories were used. There were seven themes related to the obtained codes from the study. These were: Understanding of Mathematics, Importance of Mathematics, Knowing Mathematics, Nature of School practices, Mother Competency, Mother as Resource Provider, and Mother as Motivator. The study tried to explain whether their parental roles can be explained through the context of parental views of the importance of the subject and their involvement, through expectations for successful outcomes as a result of their involvement. Additionally, this study tried to investigate whether the education level of parents' effect their parental involvement their children's mathematical learning process.

Key words: parental involvement, parents' roles, mathematics, learning, teaching, student motivation.

INTRODUCTION

Parental Involvement

There is a long history of studying parental involvement in students' education (Berger, 1991). The home was recognized as the base of education nearly over 100 years ago, and the role of parents in their children's education continues to be recognized today (Cai, 2003). Jeynes (2005) created an operational definition of parental involvement as "parental participation in the educational processes and experiences of their children" (p.245). This definition includes parental involvement related to education within the school and also in the home of each child. Research has shown that parents who are involved in their child's education contribute not only to higher academic achievement but also to positive behaviors and emotional development (Eccles & Harold, 1993, Epstein, 1986, Cai, 2003). As the relationship between parents and school becomes more connected, student achievement increases (Epstein et al., 2009).

Pomerantz, Moorman, and Litwack (2007) differentiated between school- based and home-based involvement: School-based involvement requires parents to make actual contact with school personnel (for example, attending school meetings, talking to teachers, supporting school events, and volunteering time at the school). On the other hand, home-based involvement encompasses assisting with homework, responding to children's academic performance, and talking with children about happenings at school (Pomerantz et al., 2007). Recent studies suggest that the importance in examining the home involvement of parents' in their children's motivation and success (Cai, 2003). In a study of sixth through eighth graders, Grolnick and Slowiaczek (1994) found that the three dimensions were relatively independent and were associated with children's motivational resources and school performance. Specifically, mothers who were high in behavioral and cognitive involvement had children who felt more competent in school and more in control of school outcomes than those who were less involved. In turn, these motivational resources predicted school grades (Grolnick & Slowiaczek, 1994).

Among the studies examining parental roles supporting students' learning in home settings, only a few of them have been done to examine parental support in home settings involving mathematics with early childhood and elementary school children (e.g., Anderson, 1997). Recently, Cai et al. (1999) have identified five parental roles in middle school students' learning of mathematics: motivator, monitor, resource provider, mathematics content adviser, and mathematics learning counselor. Mathematics content adviser and mathematics learning counselor are roles that parents play in directly assisting students' learning of mathematics in the home setting. Parents as motivator, monitor, and resource provider are roles that parents play in providing emotional and resource support in students' learning. (Cai, 2003).

How does parents' education affect parental involvement?

Another issue is that parents' levels of involvement in school may be influenced by qualities of the parent-child communication and by characteristics of each member (Hoover-Dempsey, Bassler & Brissie, 1987). Within this category, parents' thoughts and beliefs about themselves as parents are one set of such characteristics. First, parents differ in terms of their ideas about their role in their child's learning. To the extent that they believe strongly that parents have a role in the teaching-learning process, they may be more likely to take on involvement activities. Further, personal efficacy is also likely to impact on behavior (Bandura, 1986). Parents who believe they can make a difference are more likely to be involved (Hoover-Dempsey, Bassler & Brissie, 1987). In this study, we will try to investigate how education level of parents' affects their motivation and willingness to parental involvement in their children's learning. According to the Tsui (2005), the education level of a parent is a significant predictor of a child's educational achievements and behavioral outcomes.

Theoretical Background

Expectancy-value theory and attribution theory are based in the notion of motivation and could explain differing parents' motivation to help their children learn mathematics in ways identified as meaningful in previous research (Cai, 2003). In expectancy-value theory, individuals' expectancies for success and the value placed on succeeding are important determinants of motivation to perform different tasks (Eccles & Wigfield, 2002).

The concept of *expectancy* represents the idea that most individuals will not choose to do a task or continue to engage in task when they expect to fail. The expectancy construct concerns the answer to the question "Can I do this task?" If the answer is yes most people will choose to engage in the task. If the answer is no or there are doubts about one's capabilities to succeed, individuals are less likely to engage in the task (Pintrick & Schunk, 2002). The other half of the equation is the *value* component. Value refers to the different beliefs students have about the reasons they might engage in a task. It concerns the answer to the question "Do I want to do this task and why?" Both components are important for predicting people's future choice behavior, engagement persistence and actual achievement. (Pintrick & Schunk, 2002). All parental involvement in mathematical learning is likely to be influenced by parents' perceived importance of mathematics which is value; and an expectation of success that may result from their involvement which is expectancy (Hunt & Hu, 2011).

Attribution theory suggests parental involvement in mathematics depends heavily on the controllable or uncontrollable factors involved in the task and the connected need for achievement (Weiner, 1972). Attributing an outcome to a stable cause such as ability or skill has a stronger influence on expectancies for future success than attributing an outcome to an unstable cause such as effort. This is an important point when considering parental roles and why certain parents become more involved than others. Weiner (1972) states that if individuals are high in achievement motivation perceive that effort is an important determinant of outcome that is high effort produces success and low effort results in failure. This study will expand understanding of the nature of involvement in students' mathematical learning by explaining the influences of mothers' perceptions and beliefs toward mathematics through expectancy-value and attribution theories. Specifically, this research answers the following questions:

1. What are the mothers' personal experiences in learning mathematics?
2. Why might their views, experiences and education level influence engagement of parents' regarding their child's mathematics learning?

METHODS

Design and Context of the Study

A purposive sampling was used throughout all sampling process, that's while choosing the school, the class, and the parents (mothers). Three seventh grade students' (students were also chosen from boys to eliminate the possible biases come from gender differences regarding the motivation and success in mathematics) mothers were accepted to participate to the study. Each mother was from different education level, that's one left the school from second grade and did not turn back again, another was graduated from high school, and the last one graduated from university. Additionally, two of them were housewives and the last one graduated from university, was working as Turkish teacher. Efforts were taken to interpret all research data by using various verification strategies. Verification of data analysis, resulting codes and themes, and guards against external threats to validity were achieved through a variety of means. First, two independent coders reviewed transcripts at stages two of data analysis (Grbich, 2007). Codes were deemed to be reliable if we achieved 90% agreement or greater. We reached consensus on our disagreements by having discussion on them. Second, reliability of source information was obtained through the use of verbatim translation (Grbich, 2007).

Data Sources and Data analysis

Interviews were the primary data collection method employed in the study to gain an in-depth understanding of the research questions. Each mother participated in one interview session focusing on parents' perceptions of mathematics teaching and learning and questions relating to each mother's perceived roles in her child's mathematical learning. An interview protocol was utilized during the interview process. Questions used were open-ended to allow participants to supply researchers with as little or as much information as they felt necessary to express their thoughts (Grbich, 2007). Each mother was interviewed five to ten minutes. The analysis of interview data involved stages of identifying, sorting, and analyzing. First, all interviews were audiotaped and transcribed verbatim (Grbich, 2007).

RESULTS AND FINDINGS

We came to a consensus on seven themes that were obtained from the interviews. These are Understanding of Mathematics, Importance of Mathematics, Knowing Mathematics, Nature of School practices, Mother Competency, Mother as Resource Provider, and Mother as Motivator. Table 1 shows the obtained themes from the study. Following each theme will be briefly explained.

Interview Themes	Indicators		
	Parent 1	Parent 2	Parent 3
Understanding of Mathematics	Calculations	Calculations Difficult Formulas Practice Develop thinking	Calculations Certainty
Importance of Mathematics	Will use in future/other areas Shopping	Will use in future/other areas Shopping Requirement	Will use in future/other areas Shopping Requirement
Knowing Mathematics	Hard work Practice Listening teachers	Hard work Practice Application Integration	Hard work Interest Ability Practice Application Motivation Repetition
Nature of School practices	No idea	Too simple Lack of depth Lack of application	Lack of student interest Crowd of classes Different levels of students
Mother Competency	Bad Can't do	Not good, not bad Can't do Try to be better	Not good, not bad Can't do Doesn't like
Mother as Resource Provider	Provide additional test books	Provide additional test books Send to course Search on internet Get help from teacher	Provide additional test books Send to course
Mother as Motivator	Verbal motivation	Verbal motivation Modeling	Verbal motivation

Table 1: Seven Themes Obtained from Interviews

Understanding of Mathematics

The first theme uncovered relayed parents' perceptions of the nature of mathematics. This theme revolved around ideas and memories of parents' own learning of mathematics and parent's perceptions of the learning process.

Importance of Mathematics

We defined this theme as importance of mathematics, which revolved around parents' appreciation of mathematics as a learning phenomenon as well as the relevance of mathematics to life events.

Knowing Mathematics

Knowing mathematics refers to parents' views on what it takes for someone to come to know and excel at mathematics.

Nature of School practices

The fourth theme revealed thoughts concerning how mathematical practices occur in classroom environment. Specifically, it was focused on the mothers' beliefs related to effectiveness of these practices.

Mother Competency

In general, last three themes dealt with parental roles in children's mathematical learning and factors that might have influenced these roles. Specifically this theme uncovered related to parents' feelings of competency regarding their own knowledge of mathematics.

Mother as Resource Provider

The seventh theme was about parents as resource providers for their children.

Mother as Motivator

The final theme dealt with a mother being a motivator of her child's learning process.

DISCUSSION AND CONCLUSION

The results of this study suggest that parental roles in mathematics can be explained through the context of perceptions of their views about math, expectations for successful outcomes as a result of their involvement.

Apparent in the results was the difference in the importance of mathematics between mothers. According to expectancy-value theory, perceptions of task utility (important or unimportant) could be influenced by a person's interpretations of their own past performance in mathematics and their affective memories (Eccles & Wigfield, 2002). Indeed, two mothers remembered doing not too bad in math seemed to value the subject more than another who remembered doing poorly or who attached a negative connotation to the subject. This valuing or devaluing could prove to affect the support given to children or the type of support given like being motivators (Eccles & Wigfield, 2002).

According to attribution theory, beliefs about a person's own mathematics ability or efforts may lead to feelings of controllability or uncontrollability on the part of the parent. This can lead them to become more or less involved in their child's learning or to become involved in qualitatively differing ways (Weiner, 1972). For example, second mother who has the most comfort with math, mentioned to do extra work with their children or brought mathematics into daily life routines. But the first mother who has a not a good education memory seemed to not to be involve in the process that she states that she have no ability of mathematics.

In Eccles (2005) revealed that parental involvement is actually more important than the school itself when it comes to students' academic achievement. She also pointed out that children learn by example, often through observations at home. If a child's parents are reading books, attending ongoing education classes and taking him along to the museum and they are engaging him in a number of direct-learning experiences that will help him value achievement and success (Eccles, 2005). This kind of role modeling can be seen as in the current study. One mother mentioned her taking night courses of mathematics to be more helpful for his son; and her studying with him is a good example for this issue. Also her efforts seemed to make him give more value to studying math. Again according to Eccles (2005), parents with higher education levels have stronger confidence in their child's academic abilities, and they also have higher expectations of their child. They expect that their child will earn good grades, behave well in school and attend college. These high expectations motivate their child to do well. The confidence they have in their child builds his own confidence in his academic abilities and makes him more likely to succeed. Mother 2 and mother 3 were good examples of this explanation regarding their high expectations from their children.

The study of Tsui (2005) indicated that the education level of a parent is a significant predictor of a child's educational achievements and behavioral outcomes. Parents, who are educated raise children to have healthy self-perceptions when it comes to their academic abilities, engage them in intellectual activities that help them develop a healthy attitude about learning. In current study, mother 1 was non-educated and she was and felt

herself inadequate to help her child. Since her education background was bad, she thought she do not have ability and prefer to refrain from the education process. Moreover she does not have any ideas, who are the teachers of her son and what is going on in school practices. This is a result of expectancy-value construct as well as a result of education level of parents. When we look at the mother 2, it is clear that there is not a very good memory of math with her, but she seemed to spend admirable effort to be better in math for being more helpful for her child. This is what her education level makes her more motivated to success, believes herself to be better, and related to these to participate in her child's mathematical learning process.

RECOMMENDATIONS

The results of the present study extend previous research literature in two important ways that hold implications for teacher educators and parents. First, the use of attribution and expectancy-value theories offered unique perspectives on the reasons parental support offered in mathematics to children may differ that have not been previously discussed. Previous research identified how support is offered by different parents; notions of mothers' need for achievement in parental roles.

Additionally, although the sample size was small and means of data collection were modest, the study leaves open the door for important future research regarding the possible improvement of parental involvement in mathematics learning.

REFERENCES

- Anderson, A. (1997). Families and mathematics: A study of parent-child interactions. *Journal for Research in Mathematics Education*, 28, 484-511.
- Bandura, A. (1986). The explanatory and predictive scope of self-efficacy theory. *Journal of Social and Clinical Psychology*, 4, 359-373
- Berger, E. H. (1991). Parent involvement: Yesterday and today. *The Elementary School Journal*, 91, 209-219.
- Cai, J. (2003). Investigating parental roles of students' learning of mathematics from a cross-national perspective. *Mathematics Education Research Journal*, 15(2), 87-106.
- Cai, J., Moyer, J. C., Wang, N. (1999). Parental roles in students' learning of mathematics: An exploratory study. *Research in Middle Level Education Quarterly*, 22, 1-18.
- Eccles, J. S., & Harold, R. D. (1993). Parent-school involvement during the early adolescent years. *Teachers College Record*, 94, 568-587.
- Eccles, J. S., & Wigfield, A. (2002). Motivational beliefs, values, and goals. *Annual Review of Psychology*, 53, 109-132.
- Eccles, J. S. (2005). Influences of parents' education on their children's educational attainments: the role of parent and child perceptions, *London Review of Education*, 3, pp.191-204.
- Epstein, J. S. (1986). Parents' reactions to teacher practices of parent involvement. *The Elementary School Journal*, 86, 277-294.
- Epstein, J. L., Sanders, M. G., Sheldon, S., Simon, B. S. Salinas, K.C., et al. (2009). *School, family, and community partnerships: Your handbook for action* (3rd ed.). Thousand Oaks, CA: Corwin Press.
- Grbich, C. (2007). *Qualitative data analysis: An introduction*. Los Angeles, CA: Sage.
- Grolnick, W. S., & Slowiaczek, M. L. (1994). Parents' involvement in children's schooling: A multidimensional conceptualization and motivational model. *Child Development*, 64, 237-252.
- Hoover-Dempsey, K. V., Bassler, O. C., & Brissie, J. S. (1987). Parent involvement: Contributions of teacher efficacy, school socioeconomic status, and other school characteristics. *American Educational Research Journal*, 24, 417-435.
- Hunt, J. H., & Hu, B. Y., Theoretical Factors Affecting Parental Roles in Children's Mathematical Learning in American and Chinese-Born Mothers, *The School Community Journal*, 2011, Vol. 21, No. 2
- Jeynes, W. H. (2005). A meta-analysis of the relation of parental involvement to urban elementary school student academic achievement. *Urban education*, 40(3), 237-269.
- Pomerantz, E., Moorman, E., & Litwack, S. (2007). The how, whom, and why of parents' involvement in children's academic lives: More is not always better. *Review of Educational Research*, 77(3), 373-410. doi: 10.3102/003465430305567
- Pintrich, P. R., & Schunk, D. H. (2002). *Motivation in education: Theory, research, and applications*. Columbus, OH: Merrill.
- Tsui, M. (2005). Family income, home environment, parenting, and mathematics achievement of children in China and the United States. *Education and Urban Society*, 37(3), 336-355.
- Weiner, B. (1972). Attribution theory, achievement motivation, and the educational process. *Review of Educational Research*, 42.

Wigfield, A. & Eccles, J.S. (2000). Expectancy-value theory of achievement motivation. *Contemporary Educational Psychology*, 25, 68-81

STUDENTS OPINION ABOUT EXTRA CURRICULAR EXERCISES WHICH PERFORMED WITHIN THE SCOPE OF PROJECT BASED LEARNING

Şahin İDİN
İpek Yolu Ortaokulu
sahinidin@hotmail.com

Pınar Özdemir ŞİMŞEK
Hacettepe Üniversitesi
pozdem@hacettepe.edu.tr

ABSTRACT: This research aimed to define the views that related to effects of the projects made by the secondary school students in their extracurricular exercises on their Science and Technology lesson's achievement. The study group is consisted of seven students in a secondary school in Ankara. In this research, the qualitative research technique has been internalized. The data has been consisted of the observation of the environments that the research made and the interview that made with the students. The structured interviews have been made with the 5 students who participated in the project study with the interview forms that consisted of the open ended questions. The 7 students who form the research have been observed. They defined that the project study brought positive contribution on their Science and Technology lesson; it made them develop positive attitudes and provided them to make the connection with the other disciplines. It has been among the other suggestions that these kinds of studies made as an extracurricular exercises within the concept of the Science and Technology lesson can be used during the class effectively.

Key words: Science and Technology, Project Based Learning, Qualitative Methods

FEN BİLGİSİ EĞİTİMİ İÇİN WEB TABANLI ÖĞRENME ORTAMI

WEB BASED LEARNING ENVIRONMENT FOR SCIENCE EDUCATION

Mustafa Ali AKCA

Süleyman Demirel Üniversitesi Eğitim Fakültesi Bilgisayar ve Öğretim Teknolojileri Eğitimi Bölümü
mustafaakca@sdu.edu.tr

Esra BARUT

Süleyman Demirel Üniversitesi Eğitim Fakültesi Bilgisayar ve Öğretim Teknolojileri Eğitimi Bölümü
esrabarut@sdu.edu.tr

Rasim ÖNDER

Süleyman Demirel Üniversitesi Eğitim Fakültesi Bilgisayar İlköğretim Bölümü Fen Bilgisi Eğitimi
rasimonder@sdu.edu.tr

ÖZET: Bu çalışmada fen öğretiminde öğrencilerin uzaktan öğrenmelerini sağlayabileceği web tabanlı öğrenme ortamı tasarlanmıştır. Bu e-öğrenme ortamına çoklu öğrenme uygulamaları eklendi ve kalıcı öğrenmenin oluşması amaçlandı. Tasarlanan bu e-öğrenme ortamı ile öğrenciler istediği anda ve mekânda ders içeriğine erişebilecek ve kendini sınama imkânı yakalayabilecektir. Hazırlanan bu e-öğrenme ortamı bireysel öğrenmeye imkân tanımakta ve ihtiyaç halinde tekrarlanabilmektedir. Aynı zamanda fen eğitimi için hayati öneme sahip laboratuvar etkinliklerinin yapılmasına ve tekrarlanabilmesine olanak sağlamaktadır. Öğrenci velileri, öğrenci faaliyetlerini tablo ve grafikler üzerinde takip edebilmektedirler. Ortamın geliştirilmesinde konu anlatımları, sınavlar ve grafikleri için asp tabanlı bir web ara yüzü, ders içerisindeki etkinlik ve deneyler için flash tabanlı etkileşimli animasyonlar, sistemin donanım alt yapısında ise windows tabanlı bir sunucu kullanılmıştır.

Anahtar sözcükler: fen bilgisi, e-öğrenme, etkileşimli öğrenme, çoklu ortam.

ABSTRACT: In this study, web based learning environment designed that could provide distance learning of students in science education. This e-learning environment added to multiple learning application and it is aimed to permanent learning. Designed with the e-learning environment, students can access the course content that want to at the time and place, they are able to capture to facility the self test. It is prepared this e-learning environment, allowing to learn individual can be repeated as needed. At the same time, it is permitting conducted and repeated to laboratory activities of withal importance for science education. Parents of students are able to follow to students activities on the chart and graphs. Environment in developing and asp based web interface for description of the subject, exams, graphics, flash based interactive animations for event and experiments in course and it is used windows based in the systems hardware infrastructure.

Key words: science education, e-learning, interactive learning, multiple environment

GİRİŞ

Geçmişten günümüze kadar ağırlıklı olarak geleneksel yollarla eğitim-öğretim faaliyetleri verilmeye devam etmiştir. Çağımızın gelişen teknolojisiyle beraber geleneksel eğitim-öğretime katılmayanlara yönelik olarak alternatif öğretim yöntemleri geliştirilmeye başlanmıştır. Bunlardan bazıları uzaktan eğitim, e-öğrenme, web tabanlı öğrenme gibi yollarla sağlanmıştır. Böylece eğitim-öğretim programlarına katılmayan öğrenciler web teknolojileri sayesinde öğrenimine devam edebilmekte veya eğitim-öğretimini sürdüren öğrenciler ise kendilerini farklı alanlarda geliştirme, bilgilerini revize edebilme imkânı bulmaktadırlar. E-öğrenmenin materyal, araç-gereç bakımından güçlük çekilen fen bilimlerine uygulanması da fen öğretiminin sağlanmasında oldukça kolaylık sağlamıştır. Bu yolla laboratuvarı olmayan veya materyal bakımından yetersiz durumda bulunan okullarda bilgisayar üzerinden web ortamında öğrencilere istenilen deney ve etkinlikleri kolayca yapma ve öğrendiklerini uygulama olanağı sağlanmaktadır. Bu doğrultuda bu çalışmada öğrencilerin okulda öğrendikleri bilgilerini evde tekrarlayabilmesi, eksik kaldığı konularını tamamlayabilmesi için bir e-öğrenme ortamı oluşturulmuştur. Bu e-öğrenme ortamına çoklu öğrenme uygulamaları eklenerek kalıcı öğrenmenin oluşması

amaçlanmıştır. Tasarlanan bu e-öğrenme ortamı ile öğrenciler istediği anda ve mekânda ders içeriğine erişip çalışabilecek ve kendini sınama şansını yakalayabilecektir.

E-Öğrenme

E-öğrenme; öğrenmenin istenildiği zaman, istenildiği yerde, istediği bilgiye ulaşılabilen ve öğrenmeyi sağlayan internet teknolojileri kullanılarak yapılan eğitim tekniğidir. Elliot Masie'in tanımına göre ise; (USA'da e-öğrenme gurusu), "Çevrimiçi öğrenme bir kurs alma gibi değildir, masaüstünde e-öğrenme aracına bağlantı sağlama ve kaynakların, iletişimin, performans desteğinin ve yapısal öğrenme aktivitelerinin harmanlanmasıdır." (The MASIE center: 2011, akt: Işık, Yağcı, 2011). E-öğrenme iki farklı şekilde yapılabilir. Birincisi öğrenenin kendi başına başkalarından bağımsız olarak istediği zaman bilgiye ulaşıp öğrenebilmesidir. İkincisi ise öğrenenler ve öğretici aynı anda internet ortamında bir sınıf oluşturarak öğrenmenin sağlanması şeklindedir.

E-öğrenmenin özellikleri:

- E-öğrenme daha hızlı ve esnek bir öğrenmeyi sağlar.
- E-öğrenme öğrenme için ikinci bir yol değil öğrenmeyi destekleyen bir değer olarak ele alınmalıdır.
- Öğrenci okulda öğrendiklerini e-öğrenme yoluyla pekiştirip destekleyebilir veya eksik öğrenmeleri tamamlayabilir.
- E-öğrenme öğrenci merkezlidir; öğrenci istediği zaman bilgiye defalarca ulaşabilir istediği kadar tekrar edebilir ve istediği hızda ilerleyebilir. Böylece öğrenme maliyetini de düşürür.
- Öğrencinin e-öğrenme ortamında yaptıklarına ilişkin bilgiler istatistiksel olarak tutulup veli bilgilendirilebilir.
- Eğitim içerikleri standarttır, tüm öğrenciler aynı bilgiye ulaşabilir.
- Bu çalışmada da görüldüğü üzere e-öğrenme ortamlarında öğrenci kendi kendini test edebilir ve tecrübeli öğretmenlerden yardım isteyebilir (Duran, Önal ve Kurtuluş, 2006).
- Bireyselleştirilmiş öğrenmeyi sağlayarak grup baskısından uzak kaldığı için motivasyonu artırır.
- E-öğrenme ile öğretmen-öğrenci iletişimi daha kolay sağlanabilmektedir.
- Öğrenci öz-düzenleme konusunda yetersiz ise e-öğrenme başarısız sonuçlar doğurabilir. Aynı zamanda iletişim sorunları ortaya çıkmasıyla sosyalleşmeyi engelleyebilir.
- Öğrenciler ve öğretmenler bilgisayar ve internet konusunda yeterli bilgiye sahip olamayabilirler, bu da teknik aksaklıklara yol açabilir (Altıparmak, Kurt ve Kapıdere, 2011).

E-öğrenme ortamlarına çeşitli animasyonlar, oyunlar ve görsel nesnelere desteklenmesiyle öğrencilerin dikkati artırılabilir. Özellikle soyut kavramların öğretiminde bu tür görsel nesnelere öğrenme kalıcılığını artırır. Bu çalışmada da görüleceği üzere fen öğretiminde yapılması zor olan deneylerin yapılması veya soyut kavramların öğretiminde animasyonların kullanılması anlamayı kolaylaştıracaktır.

Çoklu Ortamlarda Eğitim

Çoklu ortam uygulamaları; değişik veri tiplerini, bilgiyi ve içeriği açıklamak için bir arada dijital ortamlarda kullanılmasıdır. İnternet hızının yavaş olduğu dönemlerde çoklu ortam uygulamaları daha çok cd ve dvd gibi ortamlar üzerinden kullanılmaktaydı. İnternetin hızının artması ve yaygınlaşması ile birlikte çoklu ortamların kullanımı artış göstermektedir. Çoklu ortamlar içerik olarak; ses, görüntü, video, tablo, animasyon, simülasyon vb. türleri olabilir (Gülbahar, 2012).

Bu çalışmada eğitici, öğretici değeri olan çoklu ortam içerik türleri kullanılarak öğrenmeyi kolaylaştırıp hızlandırarak aynı zamanda çalışmaya olan istekliliği ve motivasyonu artırarak öğrenmeye yardımcı olması sağlanmıştır. Çoklu ortamların birden fazla duyu organına hitap edebilmesi özelliği ile kalıcı öğrenme kolaylaştırılır, çeşitli zekâ düzeylerine sahip bireylerin öğrenmesi sağlanabilir (Gündüz, 2009). Öğrenciler; işitsel ve görsel öğrenmenin yanında uygulayarak, deneme-yanılma ve hatalarını fark edip düzeltmesi ile bilgiyi aktif olarak yapılandırır. Aynı zamanda karmaşık konuların veya soyut kavramların öğrenilmesinde çoklu ortamların kullanılması öğrenme düzeyini artırmaktadır (Alakoç,2003). Bu çalışma kapsamında hazırlanan çoklu ortam içerikleri ile fen bilgisi dersinde imkân yetersizliğinden, güvenlik açısından veya zorluğundan dolayı deneyleri bilgisayar ortamında kolaylıkla yapılabilmesi ve defalarca denenebilme imkânının bulunması öğrenciler için büyük bir avantaj oluşturmaktadır.

Öğretim süreci boyunca yenilikçi öğretim teknolojilerinin kullanımı her sınıf ve okul düzeyi için önemli olsa da fen ve teknoloji dersi için faydalı olmanın dışında gerekli ve önemli bir yer tutmaktadır. Milli eğitim Bakanlığı'nın fen ve teknoloji dersi için hazırladığı öğretim programında bilgisayar, iletişim ve teknoloji

ürünlerinin ders içeriği öğretiminde kullanılmasının önemi vurgulanmakta ayrıca hem öğrenciler hem de öğretmenlerin bu teknolojilerden faydalanması istenmektedir (MEB, 2004). Ayrıca fen bilgisi müfredatı ele alınacak olursa; konuların birden çok kavram içermesi, kavramların birbirine yakın olması, konuların belli bir kısmının soyut ve anlaşılmasının güç olması ve dinamik bir yapıya sahip olmasından dolayı teknolojiyi kullanma ihtiyacı oldukça fazladır. Öğrenciler bu tür konuların bilgisini alıp, ön öğrenmelerini yeni bilgilerle ilişkilendirip yapılandırırken, her safhasında güçlükler yaşamaktadır. Bu sebeple ilköğretimin her kademesinde fen ve teknoloji derslerinde yer alan konuların öğretilmesinde yeni teknolojilerin olanaklarından faydalanılmalıdır. Sunulan imkânlar ile fen, teknoloji, toplum ve çevre gibi hayatın her alanında kendisine yer bulmuş kazanımlara sahip fen ve teknoloji dersinin kazanımları daha kolay, kalıcı, doğru anlaşılması ve öğrenilmesi sağlanabilir.

UYGULAMA ORTAMI

Uygulama ortamı her ders için 5 temel öğeden oluşmaktadır. Bunlar konu anlatım ekranı, video izleme ekranı, etkinlik ekranı, sınav ekranı ve soru sorma ekranıdır. Öğrenciler ortama ilk girdiklerinde sınıflarına göre tüm konuları görebilmektedirler. Bir konuyu başarıyla bitirmeyen öğrenci diğer konuya geçememektedir. Öğrenciler bu ekranda konuyu detaylı bir şekilde öğrenip, uygulama ve deneyleri tamamlayıp, ilgili testleri çözüp eğer varsa eğitimcilerle sorup diğer konuya geçmektedir. Böylece tam öğrenmenin temelleri atılmıştır.

Ortamın Altyapısı

Ortamın yazılım alt yapısı MSSQL, ASP, AJAX ve JAVASCRIPT, donanım alt yapısı ise Windows Server 2008 kullanılarak oluşturulmuştur.

MSSQL Server Windows ve web tabanlı uygulamalarda veri saklama çözümlerinde kullanılan bir sunucu yazılımıdır. SQL Server ile veriler saklanıp, işlenip, analiz ve raporlama işlemleri yapılabilir. Derslere ait konu anlatımları, konulara ait testler, öğrencilerin ve eğitimcilerin bilgileri, temel istatistikler ve soru cevap bilgilerinin hepsi MSSQL veri tabanında tutulmaktadır.

Eğitmen ve öğrenci ekranlarının tamamı ASP kullanılarak tasarlanmıştır. ASP (Active Server Pages), Microsoft'un dinamik web sayfaları oluşturmak amacıyla geliştirdiği sunucu tabanlı çalışan betik motorudur. Klasik ASP olarak da bilinir. ASP kodları HTML sayfalarının içine gömülüp çalıştırıldığında ekran çıktısı sadece HTML kodları olarak görünür.

Öğrenciler konuya ait testleri çözerlerken soruların yanıtlanması ve süre kısıtlaması gibi fonksiyonların tamamında javascript kullanılmıştır.

Windows Server 2008, sunucu tabanlı Microsoft Windows işletim sistemlerinin bir sürümüdür. Ortamın donanım alt yapısında MSSQL veri tabanı ve ASP tabanlı uygulamanın çalışabilmesi için Windows 2008 sunucu kullanılmıştır.

Ayrıca ders içerisindeki deneysel işlevlerin gerçekleştirilmesi etkinliklerin yapılabilmesi için derslere özel olarak FLASH tabanlı deney ortamları oluşturulmuştur.

Ortamın Ana Bileşenleri

Öğrenci Konu Anlatım Ekranı

Şekil 1'deki öğrenci konu anlatım ekranında, öğrenci konuya ait bilgileri metin ve resim olarak detaylı bir biçimde görüntüleyebilmektedir. Öğrenci konuyu online olarak internet üzerinden takip edebileceği gibi ilgili üniteye ait ders metnini pdf olarak bilgisayarına kaydedebilir.



Şekil 1. Öğrenci Konu Anlatım Ekranı

Öğrenci Video İzleme Ekranı

Bu bölümde öğrenciler ders anlatımından sonra derse ait kısa videolar izleyebilmektedir. Şekil 2'de görülen ders videoları öğrencilerin anlayabileceği şekilde basit grafiklerden oluşturulmuş ve seslendirilmiştir.

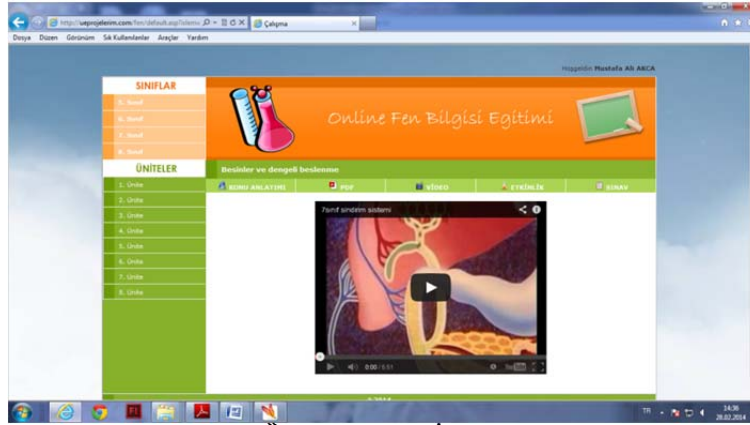

Şekil 2. Öğrenci Video İzleme Ekranı

Öğrenci video sayfasına girdiği andan itibaren bu sayfada geçirdiği sürede istatistiksel olarak takip edilmekte, bu veriler sınıf ortalaması ile karşılaştırılıp öğrenci velisine sunulmaktadır.

Öğrenci Etkinlik Ekranı

Öğrenci etkinlik ekranları konu anlatımı ve videodan sonra konunun daha iyi pekişmesi için gerekli olan etkinlikleri ve deneyleri kapsar. Deney ortamındaki tüm malzemeler öğrencinin kontrolü altındadır. Şekil 3'teki bu yapı flash kullanılarak tasarlanmıştır. Öğrenciler deney alanındaki malzemeleri konuya uygun şekilde kullanarak etkinliği tamamlar.

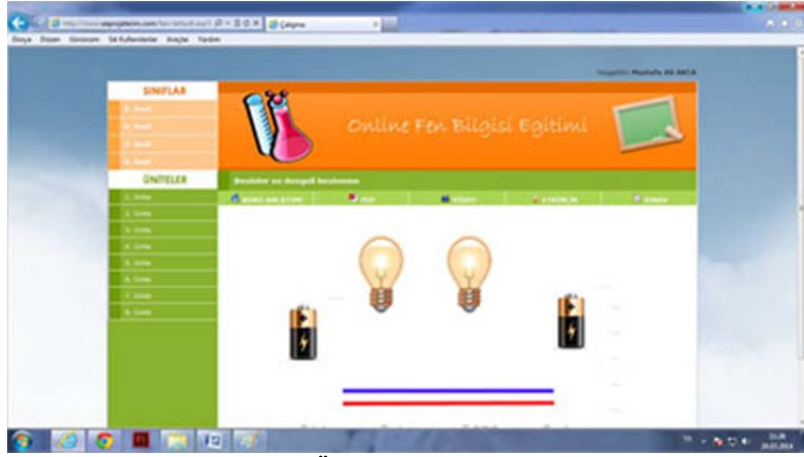

Şekil 3. Öğrenci Etkinlik Ekranı

Öğrenci Sınav Ekranı

Derse ait konu anlatımı, video izleme ve etkinlik yapma işlemleri bittikten sonra öğrenciler Şekil 4'te görülen çoktan seçmeli ve boşluk doldurma şeklinde 2 farklı tür sınava tabi tutulmaktadır. Snavlarda belirttiğimiz orandaki başarı sağlanana kadar öğrenciler yeni konuya başlayamamaktadır.

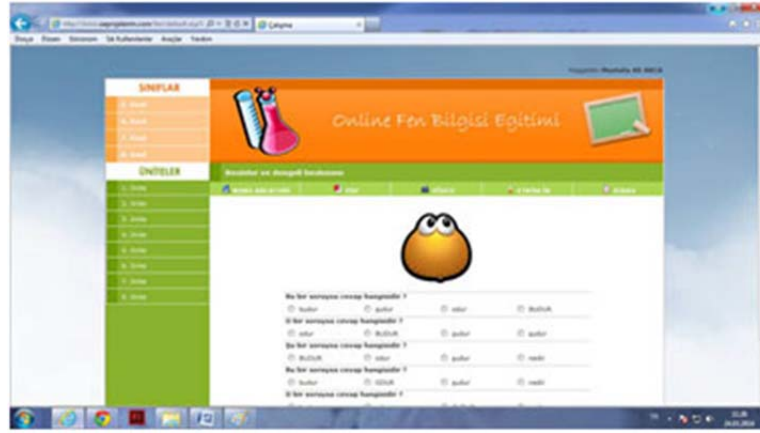

Şekil 4. Öğrenci Sınav Ekranı

Sınavla ilgili veriler istatistiksel olarak tutulup veli ekranına yansıtılabilmektedir. Öğrenciler çoktan seçmeli ve boşluk doldurma sınavını başarıyla tamamladıktan sonra yeni üniteye geçebilmektedir.

Veli Ekranı

Veli ekranı öğrenci velisinin kendisine verilen şifreyle girebileceği öğrencinin istatistiklerinin bulunduğu bir sayfadır.

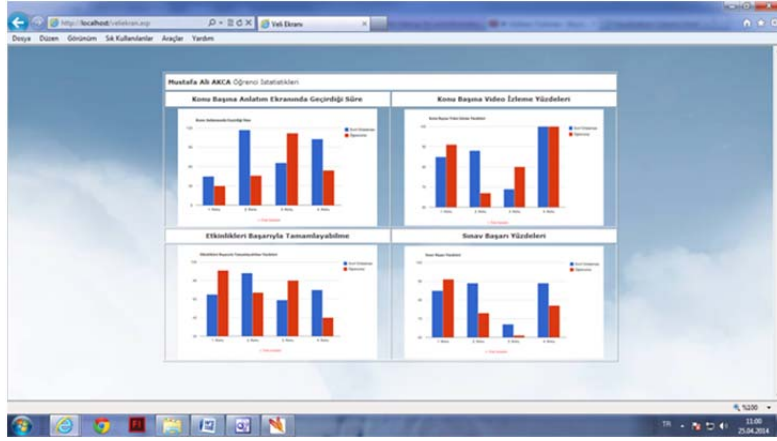

Şekil 5. Veli Ekranı

Bu sayfada veli öğrencisine ait istatistikleri görebildiği gibi, aynı istatistiklerin sınıf ortalamalarını da görebilmekte ve kendi öğrencisiyle sınıftaki diğer öğrencileri karşılaştırabilmektedir. Şekil 5'te görüldüğü gibi bu sayfada "Konu Başına Anlatım Ekranında Geçirdiği Süre", "Konu Başına Video İzleme Yüzdeleri", "Etkinlikleri Başarıyla Tamamlayabilme", "Sınav Başarı Yüzdeleri" gibi istatistikler yer almaktadır. İstatistik ekranında görülen mavi çubuklar sınıf ortalamalarını, kırmızı çubuklar ise öğrenciyi temsil etmektedir.

SONUÇ

İlköğretim fen bilgisi derslerinde öğrenciler dersin teorik kısmının işlenmesinden sonra dersin daha iyi kavranabilmesi amacıyla konuya ait etkinlikler yapması gerekmektedir. Bu e-öğrenme ortamı sayesinde dersi kaçıran veya aldığı dersi pekiştirmek isteyen öğrenciler bu e-öğrenme ortamı üzerinde çalışma şansına sahip olabilecektir. Sisteme üye olan öğrenciler, her bir konu anlatımını ve etkinlikleri tamamlayıp test aşamasına geçerek üniteyi tamamlamış olur. Ünite konuları Milli Eğitim Bakanlığı'ndaki (MEB) Fen Bilgisi programına göre sıralanmış ve aşamalılık ilkesine dikkat edilmiştir. Her bir konunun başarıyla bitirilmesinden sonra öğrenme ortamında pekiştireçlere yer verilmiş böylece öğrencilerin derse katılmaya ve çalışmaya yönelik motivasyonlarının sağlanmasına önem verilmiştir. Böylece önceki konulardaki konuyu anlama oranlarına bağlı olarak sonraki konulardaki başarıları da şekillenecektir. Geliştirilen bu e-öğrenme ortamı sayesinde öğrenciler e-öğrenme ortamına entegre edilmiş konuyla ilgili MEB'deki kitap içeriklerini okuyup, etkinlikler yaparak ve testler ile kendilerini sınyarak konuları bir bütün halinde öğrenebilmektedirler. Okulunda fen laboratuvarı olmayan, araç-gereç eksikliği nedeniyle veya tehlikeli olabilecek durumlar için fen deneylerini yapamayan öğrenciler bu e-öğrenme ortamında deneylerini yapma imkânı bulacaklardır. Etkinliklerin yapılması için flash ortamında görselliğe dikkat edilerek tasarlanan gerçekçi deney setleri hem öğrencilerin tüm deneyleri yapabilmelerini hem de öğrenci isterse aynı deneyi tekrar tekrar yapabilmelerini sağlayacaktır. Sistem çevrimiçi çalıştığı için öğrenciler gittikleri her ortamda internet üzerinden bu faaliyetleri kesintisiz olarak sürdürebilecektir. Aynı zamanda veliler de öğrencilerin ders durumlarını tablo ve grafikler halinde görebilecek ve sınıf ortalamasıyla karşılaştırıp takip edebileceklerdir.

KAYNAKLAR

- Alakoç, Z. (2003). Matematik öğretiminde teknolojik modern öğretim yaklaşımları. *The Turkish Online Journal of Educational Technology-ISSN:1303-6521*, 2(1), 43-49.
- Altınparmak, M., Kurt, İ. D. ve Kapıdere M. (2011). *E-öğrenme ve uzaktan eğitimde açık kaynak kodlu öğrenme yönetim sistemleri*. XIII. Akademik Bilişim Konferansı Bildirileri, İnönü Üniversitesi, Malatya, 319-327.
- Duran, N., Önal, A. ve Kurtuluş, C. (2006). *E-öğrenme ve kurumsal eğitimde yeni yaklaşım öğrenim yönetim sistemleri*, Akademik Bilişim Konferansı Bildirileri, Pamukkale Üniversitesi, Denizli.
- Gülbahar, Y. (2012). *e-Öğrenme (2.Baskı)*. Ankara: Pegem Akademi.
- Gündüz, M. (2009). *İnternet teknolojilerini kullanarak öğrenci başarısı ve öğrenmenin kalıcılığını artırma*. (Yayımlanmamış yüksek lisans tezi), Bahçeşehir Üniversitesi, İstanbul.

Işık, M. ve Yağcı, M. (2011). *E-öğrenme teknikleri ile örgün eğitimin desteklenmesi*. 5th International Computer & Instructional Technologies Symposium, Fırat University, Elazığ.

Masie, E. (2011). The MASIE Center, <http://www.masie.com> adresinden elde edildi.

MEB (2004). *4 – 8 fen ve teknoloji ilköğretim programı*. Ankara: MEB.

THE IMPACT OF LESSON STUDY ON PRIMARY MATHEMATICS TEACHERS' INSTRUCTIONS IN BRUNEI DARUSSALAM

Hj Ade Shahrin HJ SUHAILI
Sultan Hassanal Bolkiah Institute of Education, Universiti Brunei Darussalam
hjade501@gmail.com

Masitah SHAHRILL
Sultan Hassanal Bolkiah Institute of Education, Universiti Brunei Darussalam
masitah.shahrill@ubd.edu.bn

Madiah KHALID
Institute of Education, International Islamic University Malaysia
madiahkhalid@iiu.edu.my

ABSTRACT: This paper reports a study on the impact of “Lesson Study” on primary mathematics teachers’ instructions in Brunei Darussalam. The purpose was to determine whether Lesson Study had a positive impact on teachers’ instructions. Quantitative data were collected from; checklists from four research lesson classroom observations, and teachers’ questionnaire that was distributed to 28 practitioners and qualitative data were collected from interviews, reflective journals and the study of lesson plans. From the results, four pathways were identified in which teachers’ instructions had indeed improved, 1) Lesson plan development had broadened teachers’ content and pedagogical knowledge; 2) Observation of students’ learning helped teachers to be more conscious and sensitive towards students’ learning needs and difficulties; 3) The development of teachers’ self-confidence, teaching skills, questioning skills and classroom management skills; and 4) Feedbacks from peers and ‘knowledgeable others’ had made them more aware of the weaknesses and strengths on their own teaching.

Key words: Lesson Study; Primary Mathematics Teachers; Professional Development Program; Teachers’ Instruction; Brunei Darussalam

INTRODUCTION

The New Education System (known as *Sistem Pendidikan Negara Abad ke-21* or SPN21) provided the much needed changes and improvement towards the standard of education in Brunei Darussalam. One of the aims of the system is to equip Bruneian students with essential 21st century skills in order to meet the social and economic challenges, and compete intellectually and academically with other students internationally (Ministry of Education, 2009). Therefore there was an immediate need for the implementation of a teachers’ professional development program that can provide Bruneian teachers with sufficient content knowledge and pedagogy skills that can help them to implement the SPN21 curriculum efficiently. A teachers’ professional development program known as the Lesson Study was selected to be one of the ‘tool’ to facilitate and support the implementation process of SPN21 in Brunei Darussalam. Despite a growing body of literature on the roles of Lesson Study in facilitating educational reforms, there have been only few research publications on Lesson Study conducted in Brunei Darussalam although interest in Lesson Study in Brunei Darussalam has gained momentum since its introduction in 2009.

There has been a proliferation of research, aims to impart descriptive knowledge base of lesson study in enhancing teachers’ mathematical instructional practices. And we have since realised the importance to conduct researches on Lesson Study in schools in Brunei Darussalam and its effect towards teachers’ instructional practices. Takahashi, Watanabe and Yoshida (2006) stated that lesson study has the features to potentially influence the quality of mathematics teaching practices in the United States, and elsewhere. It offers opportunities for teachers to critically evaluate their teaching practices. The critical evaluations may take place during the planning period or post lesson discussion, in which through these evaluations, lesson study provides a concrete image of effective instructional practices. It is because of this, lesson study is seen not only as a useful tool to disseminate effective teaching practices but also a powerful mechanism to develop such practices (Takahashi, Watanabe & Yoshida, 2006). Lewis (2002) explored and identified the ‘key pathways’ that connect lesson study to the improvement of teachers’ instructional practices in the United States. These ‘pathways’ are essential to be understood if schools are to give lesson study a reasonable try in the United States (Lewis, 2002).

Given the proven success and phenomenal spread of Lesson Study in other countries over such a short period, it is important to provide a descriptive knowledge of the process of Lesson Study and its effect on Brunei teachers and students. It is hoped that the findings of this research will give valuable information regarding the effectiveness of lesson study in changing and improving teachers' instructional practices and as a 'catalyst' in changing the 'teaching culture' in Brunei primary schools. The aim of the study is to investigate the impact of Lesson Study on Brunei primary mathematics teachers' instructions. It also explored the relationships of Lesson Study and Brunei primary mathematics teachers in developing their teaching proficiency in implementing the educational reforms efficiently. The key research question is, "What is the impact of lesson study towards teachers' instructions?"

METHODS

This study has adapted a combination of both quantitative and qualitative approaches. The quantitative data were collected from two sources; the 4 research lesson classroom observations acquired from the classroom observation checklist, and teachers' questionnaire. Qualitative data were collected from the observations of planning meetings, reflective stage session, teachers' reflective journal, teachers' interview session and the study of lesson plans of the teachers.

For this study, the researchers had selected a purposive sample of teachers from 14 government schools which were involved in the Lesson Study project in 2010; a collaboration between Universiti Brunei Darussalam and the Department of Schools at the Ministry of Education, Brunei Darussalam. Four teachers from 4 schools were observed during the teaching of the research lesson using the classroom observation checklist. The purpose of using the observation checklist is to provide the necessary guidelines in observing a particular mathematics lesson. The checklist was designed to focus the researchers' and other observers' attention towards numerous teaching criteria and students' behavior that are related to the objective of Lesson Study. The lesson organization, the teachers' presentation, the teaching strategy used, the nature of teacher and students communication, assessment and students' behavior are the six areas that were observed during each research lesson. These 4 teachers were also interviewed and were required to complete a reflective journal after they have completed the Lesson Study project. The main aim of using the teachers' reflective journal was to have a clearer picture of the teacher-participants' experiences when conducting the Lesson Study processes, which include teachers' ideas, fears, mistakes, confusions and the reactions towards the experience that they have during the Lesson Study processes. Table 1 shows the demographic data of the 4 teachers from the 4 schools.

Table 1. Demographics of the 4 Teachers Involved in the Lesson Study Project

	Teacher A	Teacher B	Teacher C	Teacher D
School	SRS	SRJ	SRK	SRKT
Gender	Female	Female	Female	Female
Age-group	30-39	30-39	30-39	40-49
Highest level of education	Bachelor	Bachelor	Certificate of Education	Certificate of Education
No. of years as a Mathematics teacher	11-15 years	11-15 years	11-15 years	16-20 years

All 28 teachers from the 14 schools who were involved in the Lesson Study project were surveyed. The teachers' questionnaire was adapted and modified from three previous researches on Lesson Study and Learning Study, namely; the teachers' perceptions of the impact of the lesson study project upon their knowledge and their learning by White and Southwell (2003), 'The Learning Study – A Framework for Enhancing School-University Collaboration that Focuses Upon Individual Lessons' by Ling (2008), and by Fernandez (2005) entitled Exploring 'Lesson Study' in Teacher Preparation. The demographic information of the 28 teachers is presented in Table 2.

Table 2. Teachers Demographics

Description		Group 1 (N=8)	Group 2 (n=10)	Group 3 (N=10)
Gender	Male	0	1	4
	Female	8	9	6
Age	18-25	1	3	1
	26-35	2	7	8
	36-45	5	0	1

	46 and above	0	0	0
Highest Qualification	Certificate or Diploma	4	5	6
	Bachelor Degree	4	5	4
	Masters' Degree	0	0	0
Number of years as a Mathematics teacher	0-5 years	1	7	4
	6-10 years	4	2	5
	11-15 years	3	1	1
	16 years and above	0	0	0

RESULTS

Classroom Observation Checklist Analysis

To investigate whether the teachers' instructions were improving between the four 'cycles' of lesson study, a one-way ANOVA was used to analyze the differences of the four teachers' 'performance' and teaching based on the 'evaluation' and 'measurement' by observers using the classroom observation checklist. Table 3 shows the 4 teachers performance based on the mean scores of the observation checklist. It shows that there were substantial improvements in the mean score of instructions as the lesson cycles were progressing from Teacher A to Teacher B and to Teacher C. However, there was a decline of mean score of the instructions between Teacher C (M=108.56, SD=8.017) and Teacher D (M=101.08, SD=19.280).

Table 3. Descriptive One-way ANOVA for the 4 Teachers

	N	Mean	SD	Std. Error	95% Confidence Interval for Mean		Min	Max
					Lower Bound	Upper Bound		
Teacher A	15	94.80	11.602	2.996	88.38	101.22	74	116
Teacher B	8	105.00	11.084	3.919	95.73	114.27	93	122
Teacher C	9	108.56	8.017	2.672	102.39	114.72	100	126
Teacher D	12	101.08	19.280	5.566	88.83	113.33	72	126
Total	44	101.18	14.113	2.128	96.89	105.47	72	126

Questionnaire Analysis

A descriptive statistical data on teachers' perception of the impact of lesson study on 8 aspects of their development, as represented in section 4 of the teachers' questionnaire, was used to give a holistic and broad view of the impact of lesson study on the teachers' instructions. On the teachers' questionnaire, the teachers were asked to provide a rating for each item. The ratings were (1) no impact, (2) little impact, (3) moderate impact and (4) large impact. Table 4 shows the teachers' mean scores on every item in section 4 of the questionnaire.

Table 4. Descriptive Statistical Data of Teachers' Perception on the Impact of Lesson Study

Descriptive Statistics	N	Minimum	Maximum	Mean	Std. Deviation
Your professional development	28	2	4	3.43	.690
Your teaching skills	28	2	4	3.46	.693
Your self-confidence/self esteem	28	1	4	3.25	.844
Classroom management skills and techniques	28	1	4	3.21	.738
Students' assessment practices	28	1	4	3.32	.772
Questioning skills and techniques	28	2	4	3.57	.573
Content knowledge and understanding	28	1	4	3.29	.763
Knowledge and understanding of instructional practices	28	1	4	3.39	.737

Note: Valid N (list wise) = 28

Results from Table 4 suggests that the largest impact of lesson study was on the teachers' questioning skills and techniques ($M=3.57$, $SD=0.573$). The differences of the means of each items was not much and all items have the mean score of above 3 which indicates that lesson study have better than moderate impact on all 8 aspects of teachers' development. Positive impact on each of the 8 aspects of teachers' development can and may have positive impact on teachers' instructional practices. It can be concluded, from the entries above, that teachers' instructional practices may have been improved as a results of positive development of the 8 items above.

Qualitative Insights into the Impact of Lesson Study on Teachers' Instruction

Based on teachers' responses from the interviews and their journals, evidences suggest lesson study did have an impact on teachers' instructions and these are presented in the following areas.

The Development of Knowledge of Instructions

It was found that meaningful discussion about instructions between teachers and knowledgeable others has a positive impact on teachers' learning and hence to the improvement of their instructional practices. The following interview excerpt is consistent with the 'themes' of discussion above:

They (other group members) asked me how would I explain to students...what would I use to compare between example $3/4$ and $3/8$. Same numerator but different denominator... I mentioned that I'm going to use fraction chart to show which fraction is bigger. (Teacher A)

The Development of Capacity to Observe Students

In lesson study, ability to collect related data from observation of students' responses towards any components of the teaching of the research lesson i.e. the activities, is vital for teachers not only to assess and evaluate the lesson holistically, but also it's a prerequisite for teachers to revise their lesson plan for the next research lesson. In one of the interview session, Teacher A identified and explained the benefits of observing students' learning in the research lesson:

For me, it is beneficial for teachers, in the first and second research lessons, we can already spot the pupils' problems and weaknesses in learning the topic. We can spot who are high achiever, talk well and do well. It teaches us to observe students...now it's very easy to observe them. (Teacher A)

The Development of Teachers' Belief of Efficacy

It was found most teachers had developed a sense of efficacy; the beliefs that have changed in instructions can affect students' learning. The following responses illustrate that the sense of efficacy amongst teachers and students' learning had changed as a result of alterations in teaching methods:

- *Pupils' learning did change. It allowed them to think by themselves and they expressed their opinions and feelings of their work. (Teacher A's journal)*
- *I changed my teaching methods and affected my pupils' way of learning. They are more responsive, actively involved, communicate and think. (Teachers' D journal)*

CONCLUSION

From the analyses of all the research instruments, four pathways were identified that may lead to the improvement of teachers' instructions during the Lesson Study project.

1. Lesson plan development had broadened teachers' content and pedagogical knowledge.
2. Observing students' learning during the teaching of the research lessons helped the teachers' to be more conscious and sensitive towards students' learning needs and difficulties, and made them more critical in choosing the appropriate and most suitable activities in the lessons.
3. The development of teachers' self-confidence, teaching skills, questioning skills and classroom management skills during the process of teaching research lessons.
4. Comments and feedbacks from peers and the 'knowledgeable others' made them more aware of their weaknesses and strengths of their own teaching.

From this study, the teachers stated that they have gained a lot by observing students' learning during the teaching of the research lesson. Teachers indicated that by observing students' learning during the teaching of research lessons, they have developed a sense of consciousness and sensitivities towards students' learning needs and difficulties. It was also observed that the teachers' self confidence, teaching skills, questioning skills and classroom management skills were largely impacted during the process of teaching the research lesson. Furthermore, the teachers have built their courage to be able to 'perform' in front of peers and 'knowledgeable others'. From the experience of being observed, these teachers have developed a sense of confidence and may lead to positive effects in their subsequent teachings, classroom management and questioning skills.

Finally, the unique features of the reflective stages of Lesson Study helped teachers to assess their general weaknesses and strengths of their own teaching. These comments and feedbacks on students' learning and on their teaching in general were the key ingredient for teachers to realise their weaknesses and strengths in teaching the lessons.

RECOMMENDATIONS

The findings of this study suggested some useful implications for the use of a collaborative learning structure such as Lesson Study specifically in the Bruneian context. However, the qualitative data of the present study only involved the 4 schools. Other groups of the Lesson Study project that focused on different mathematics topics and different level of students were not explored qualitatively. Further researches are necessary to consider the impact of Lesson Study on Mathematics teachers concentrating on different Mathematics topics and different levels of students.

REFERENCES

- Fernandez, M. (2005). Exploring 'lesson study' in teacher preparation. Retrieved from <http://www.edugains.ca/resources/LeadingChange/ResearchtoInformDecisions/>
- Lewis, C. (2002). *Lesson Study: A Handbook of Teacher-Led Instructional Change*. Philadelphia: Research for Better Schools.
- Ling, L. (2008). The learning study-A framework for enhancing school-university collaboration that focuses upon individual lesson. *Proceedings of the 13th international conference of Sultan Hassanal Bolkiah Institute of Education*, (pp.162-181) Universiti Brunei Darussalam.
- Ministry of Education (2009). *21st century national education system*. Retrieved from <http://www.moe.edu.bn/web/spn21>
- Takahashi, A., Watanabe, T., & Yoshida, M. (2006). *Developing good mathematics teaching practice through lesson study: A US perspective*. Retrieved from <http://www.apecneted.org/resources/downloads/Takahashi.pdf>
- White, A. L., & Southwell, B. (2003). Lesson study: A model of professional development for teachers of mathematics in years 7 to 12. In L. Bragg, C. Campbell, G. Herbert, J. Mousley (Eds.), *MERINO: Mathematics Education Research: Innovation, Networking, Opportunity. Proceedings of the 26th Annual Conference of the Mathematics Education Research Group of Australasia*. (Vol. 2, pp.744-751). Melbourne: MERGA.

**ORTAOKUL 5. SINIF MATEMATİK DERS KİTABININ ÖĞRETMEN
VE ARAŞTIRMACI GÖRÜŞLERİNE GÖRE
DEĞERLENDİRİLMESİ**

**EVALUATION OF MIDDLE SCHOOL'S 5TH GRADE MATHEMATICS
TEXTBOOK ACCORDING TO THE VIEW OF
TEACHERS AND EXPERTS**

Nadide YILMAZ
Hacettepe Üniversitesi
nadideylmz@hacettepe.edu.tr

Başak EROĞLU TORAMAN
Hacettepe Üniversitesi
bskeroglu@hotmail.com

Sinan ERTEN
Hacettepe Üniversitesi
serten@hacettepe.edu.tr

ÖZET: Bu araştırmada 2013 öğretim programına göre hazırlanmış ortaokul 5. Sınıf matematik ders kitabı incelenerek taşınması gereken özelliklere ne derece sahip olduğunun ortaya çıkarılması amaçlanmıştır. Bu amaçla literatür ve MEB'in belirlediği özellikler çerçevesinde biçimsel ve görsel tasarım, dil ve anlatım, içerik ve öğrenme alanları, konuların sunumu ve kazanımlar ile ders kitabının uyuma yeterliği açısından ortaokul 5. Sınıf matematik ders kitabı incelenmiş ve 7 öğretmenle yarı yapılandırılmış mülakatlar gerçekleştirilmiştir. Araştırmanın sonuçları 5. Sınıf matematik ders kitabının genel olarak belirlenen niteliklere sahip olduğunu ortaya çıkarmıştır. Bunun yanında bazı özelliklerin bir kısmının göz ardı edildiği, bu nedenle bu açılardan geliştirilmesi gerektiği sonucuna varılmıştır. Bu bağlamda ön bilgilerin ortaya çıkarılmasına yönelik bazı eksikliklerin bulunduğu, teknoloji kullanımının yeterince dikkate alınmadığı, etkinliklerin azlığı ve ölçme değerlendirme sorularının üst düzey beceriler açısından geliştirilmesi gerektiği söylenebilir. Bu sonuçlardan yola çıkarak bazı önerilerde bulunulmuştur.

Anahtar sözcükler: 5. Sınıf matematik ders kitabı, öğretmen görüşü, ders kitabı inceleme

ABSTRACT: In this study the middle schools 5th grade mathematics textbook, prepared according to the 2013 curriculum, has been examined with the intention to reveal to what extent specialities are required. In terms of agreement adequacy the textbook was examined within the framework that is determined by literature and ministry of national education, which are formal and visual design, language and expression, content and learning areas, presentation of the subject and gains. In addition semi structured interviews were carried out with 7 teachers. The results of the research revealed that the 5th grade mathematics textbook possess the generally determined qualities. Also it was concluded that some qualities are ignored, which should be improved by these aspects. In this context it can be said that; there are shortcomings of revealing prior knowledge, using of technology is not sufficiently considered and the questions of assessment need to be improved in terms of high level skills. Based on these results some suggestions for improvements were made.

Key words: 5th mathematics textbook, teacher opinion, textbook examination

STUDENTS' ATTITUDES TOWARDS TECHNOLOGY EDUCATION IN FINLAND, ESTONIA AND ICELAND

Ossi AUTIO
University of Helsinki, Finland
ossi.autio@helsinki.fi

Mart SOOBİK
University of Tallinn, Estonia
msoobik@tpu.ee

Gisli THORSTEINSSON
University of Iceland
cdt@hi.is

Brynjar OLAFSSON
University of Iceland
brynjar@hi.is

ABSTRACT: This paper is based on a comparative study of craft and technology education curriculums and students' attitudes towards craft and technology in Finland, Estonia and Iceland. The study was undertaken by the Helsinki University, University of Tallinn and University of Iceland in the year 2012. Even though, the origins of craft education in Finland, Estonia and Iceland have many similarities, the Estonian and Icelandic national curriculum place greater emphasis on design and innovation, whereas the Finnish national curriculum focus on the development of students' personalities and gender issues. A quantitative survey was subsequently distributed to 493 school students in Finland, Estonia and Iceland. The questionnaire consisted of 14 questions, which aimed to ascertain students' attitudes towards craft and technology. The survey showed substantial differences in students' attitudes towards craft and technology education in the three countries. In addition, significant statistical differences were found between boys and girls. These differences may be explained by differences in the national curriculums and the different pedagogical traditions. However, these findings need to be examined further through research.

Key words: attitudes towards technology, technology education, handicraft, pedagogical traditions

INTRODUCTION

Technology is determined and guided by human emotions, motivations, values, and personal qualities. Thus the development of technology in society is dependent on citizens' attitudes towards technology, technological will to participate in and in humans' technological decisions. In this study we are trying to find out if there are differences in these attitudes between students in different countries.

The general aim of Finnish Craft and Technology education is to increase students' self-esteem by developing their skills through enjoyable craft activities; it also aims to increase students' understanding of the various manufacturing processes and the use of different materials in craft. Furthermore, the subject aims to encourage students to make their own decisions in designing, allowing them to assess their ideas and products. Students' practical work is product orientated and based on experimentation, in accordance with the development of their personality. The role of the teacher is to guide students' work in a systematic manner. They must encourage pupils' independence, the growth of their creative skills through problem-based learning and the development of technical literacy. Finnish handicraft traditions are also of importance throughout the whole curriculum (Framework Curriculum Guidelines, 2004). Analysing the Finnish curricula in a long term, a smooth development can be noted. However, the Finnish curriculum has chosen to focus on the development of students' personalities and gender equality rather than technological development.

Subjects taught in the domain of technology in Estonia enable students to acquire the mentality, ideals, and values inherent to the contemporary society. They learn to understand the options they have in solving tasks or creating new products; find and combine various environmentally sustainable techniques. In lessons, students study and analyse phenomena and situations, as well as use various sources of information, integrate creative

thinking and manual activity. As a part of the study process, students generate ideas, plan, model, and prepare objects/products and learn how to present these. Students' initiative, entrepreneurial spirit, and creativity are supported and they learn to appreciate an economic and healthy life style. Learning takes place in a positive environment, where students' diligence and development are recognized in every way. Teaching develops their skills in working and cooperating, as well as their critical thinking and the ability to analyse and evaluate. (Ainevaldkond Tehnoloogia, 2011). In long term, the political situation in Estonia has considerably changed and thus there have been fundamental changes also in education, including the syllabi of craft and technology education. Nevertheless, the syllabi of the technological domain have been drawn up as a result of the developmental work in the last decades.

The present national curriculum for the subject of Craft in Iceland places an emphasis on individual-based learning. It also gives teachers the freedom to run an independent curriculum in school, which is based on the national curriculum. As in Finland, the subject is product based and students learn via traditional craft activities. Students' work is based on craft tradition rather than technology; however, innovation and idea generation are an important part of the Icelandic curriculum. There are also the aims of developing students' manual skills, instructing them in the manufacturing processes and training them to organise their own work. The national curriculum also incorporates outdoor education, working with green wood and sustainable design. When the national curriculum was revised in 2007, it was decided to minimise the technological part of the Design and Craft curriculum and the original Sloyd values were once again included in the curriculum. The curriculum moved away from the manufacturing process (i.e., mass production) and towards handicraft-based processes. However, innovation and idea generation are still an important part of the curriculum (Olafsson & Thorsteinsson, 2010).

As seen above, there are many similarities between the national curriculums in Finland, Estonia and Iceland; however there are also some differences. In the following sections, the authors will attempt to highlight these differences and will try to ascertain whether there are any differences in these three countries, with regards to students' attitudes towards craft and technology. The research questions were:

1. Are there differences in students' attitudes towards Craft and Technology in Finland, Estonia and Iceland
2. Are there differences in students' attitudes towards Craft and Technology between boys and girls?

METHODS

The aim of the empirical aspect of the research was to answer the question: Is there a difference in students' attitudes towards craft and technology in Finland, Estonia and Iceland? Dyrenfurth (1990) and Layton (1994) referred to attitudes to technology education using the concept of 'technological will'. According to these authors, technology is determined and guided by human emotions, motivation, values and personal qualities. Thus, the development of technology is dependent on the students' will to take part in lessons and on the impact of their technological decisions.

In order to evaluate students' attitudes towards craft and technology in Finland, Estonia and Iceland, a questionnaire was devised, consisting of 14 statements. For each Likert-type item, there were five options, from 'Strongly Disagree' (= 1) to 'Strongly Agree' (= 5). The questionnaire featured some questions about students' backgrounds, in addition to questions that attempted to gauge students' motivation and success, in terms of craft and technology education classes. The questionnaire was based on the PATT standards (Pupils Attitudes Towards Technology), which were designed and validated by Raat & de Vries (1986) and van de Velde (1992). Based on their work different factors were found: interest, role models, effects of technology, complexity of technology, school and technology, career plans. From this point of view the internal consistency of the questionnaire was relevant. 493 students from Finland, Estonia and Iceland took part in the survey. The age of the student-respondents was 11-13 years.

RESULTS

Some differences in students' attitudes towards craft and technology were found in the three countries. The average response in our Likert-style (1-5) questionnaire to all 14 items was among Finnish girls 3.37, Estonian girls 3.55 and Icelandic girls 3.67. Significant statistical difference was found between boys and girls, whereas the average response of boys was in Finland 3.78, Estonia 4.00 and in Iceland 3.87. Estonian boys had the most positive attitude towards technology, whereas the lowest attitude was found among Finnish girls. The difference between boys and girls was definitely the smallest in Iceland. The averages for each statement are listed in the

table 1 below.

Table 1. Average (Mean) values for each statement, with regards to the measurement of students' attitudes towards craft and technology in Finland, Estonia and Iceland

Statement number		Mean FINLAND	Mean ESTONIA	Mean ICELAND
1. Is interested in engineering and the phenomena related to it	girls	3.45	3.32	3.55
	boys	4.30	4.40	4.40
2. Spends a lot of time with engineering-related hobby activities	girls	<u>2.71</u>	<u>2.02</u>	<u>2.82</u>
	boys	3.06	3.44	3.58
3. Newspapers, magazines, and articles from the field of engineering are interesting	girls	2.35	2.87	2.82
	boys	2.83	3.50	3.00
4. Understanding engineering-related phenomena will be beneficial in the future	girls	3.45	3.59	3.59
	boys	3.95	4.43	3.95
5. Understanding engineering-related phenomena requires a special wit	girls	3.55	3.50	3.16
	boys	3.60	4.16	3.70
6. Both boys and girls may understand engineering-related phenomena	girls	<u>4.62</u>	<u>4.42</u>	<u>4.82</u>
	boys	<u>4.29</u>	<u>4.22</u>	<u>4.60</u>
7. The mankind has rather benefited than sustained damage from the development of engineering	girls	3.85	3.89	3.98
	boys	4.25	4.29	4.23
8. In the future would like to choose a speciality or a profession related to engineering	girls	<u>2.40</u>	<u>2.40</u>	<u>2.55</u>
	boys	3.26	3.39	3.25
9. Parents have a lot of engineering-related hobbies	girls	2.98	2.61	3.07
	boys	3.09	2.96	2.88
10. The atmosphere in the Technology Education / Handicraft lessons is pleasant and inspiring	girls	3.56	4.32	4.07
	boys	4.24	4.11	4.03
11. Technology Education / Handicraft lessons considerably contribute to the development of manual skills	girls	3.85	<u>4.56</u>	<u>4.66</u>
	boys	<u>4.25</u>	<u>4.56</u>	<u>4.50</u>
12. Technology Education / Handicraft lessons develop logical thinking	girls	3.60	4.12	3.89
	boys	3.84	4.24	3.93
13. Has been successful in Technology Education / Handicraft s lessons	girls	3.49	3.99	4.55
	boys	3.80	3.93	4.25
14. Technology Education / Handicraft lessons will be beneficial in the future	girls	3.51	4.09	3.82
	boys	3.90	4.39	3.88
All 14 items	girls	3.37	3.55	3.67
	boys	3.78	4.00	3.87

The highest average values in the whole questionnaire were found in statement number:

- 6. Both boys and girls may understand engineering-related phenomena (Icelandic girls 4.82, Finnish girls 4.62, Icelandic boys 4.60).
- 11. Technology Education / Handicraft lessons considerably contribute to the development of manual skills (Icelandic boys 4.66, Estonian boys and girls 4.56, Icelandic girls 4.50).
- 1. Is interested in engineering and the phenomena related to it (Estonian and Icelandic boys 4.40, Finnish boys 4.30).
- 7. The mankind has rather benefited than sustained damage from the development of engineering (Estonian boys 4.29, Finnish boys 4.25, Icelandic boys 4.23).

The lowest values were in statement number:

- 8. In the future would like to choose a speciality or a profession related to engineering (Finnish and Estonian girls 2.40, Icelandic girls 2.55).
- 2. Spends a lot of time with engineering-related hobby activities (Estonian girls 2.02, Finnish girls 2.71, Icelandic girls 2.82).
- 3. Newspapers, magazines, and articles in the field of engineering are interesting (Finnish girls 2.35, Icelandic girls 2.82, Finnish boys 2.83,)

In addition, it was found a significant statistical difference ($p < 0.05$) between boys and girls in several items. Most remarkable differences between boys and girls were found in statement number:

- 1. Is interested in engineering and the phenomena related to it
- 8. In the future would like to choose a speciality or a profession related to engineering
- 2. Spends a lot of time with engineering-related hobby activities
- 3. Newspapers, magazines, and articles in the field of engineering are interesting
- 4. Understanding engineering-related phenomena will be beneficial in the future

CONCLUSIONS

Craft education in Finland, Estonia and Iceland originated over 140 years ago and was influenced by the Scandinavian sloyd pedagogy. In the beginning, the subjects largely focused on students copying artefacts, using a variety of handicraft tools: the purpose of this was to improve their' manual skills, rather than their thinking skills. Today, the focus is also on developing students' thinking skills, which enables them to work through various handicraft processes (from initial ideas to the final products). This work is based on the idea generation of students and is thus expected to increase their self-esteem and ingenuity.

Some differences in students' attitudes towards craft and technology were found in the three countries. Definitely, the smallest difference between boys and girls was found in Iceland. This finding corroborates with comparable results from Autio, Thorsteinsson and Olafsson (2012) which shows that Icelandic girls performed better attitudes than both Estonian and Finnish girls. Hence, Finnish and Estonian craft and technology education curriculum could also benefit from Icelandic system with two different subjects: art based textile education and innovation based technology education, compulsory for both boys and girls. This is an interesting finding as the Finnish curriculum has put large emphasis on gender equity since 1970, but still Finnish girls had the most negative attitude towards technology. Finnish girls seemed to be aware of the gender equity and their highly agree with the statement: both boys and girls may understand engineering-related phenomena. However, only a few girls are willing to challenge stereotypes about non-traditional careers for women, as it could be conducted from responses to the statement: in the future would like to choose a speciality or a profession related to engineering. In addition, only few girls seemed to have technological hobbies or had interest in technological articles. What's more in Finland the boys still want to choose technical craft studies and the girls' textiles. A practical solution to get both sexes to choose both subjects has not been found.

The Estonian boys' attitudes towards craft and technology were most positive. It indicates that the Estonian curriculum that includes two different craft subjects: the technologically based 'technology' and the art based 'handicraft and home economics is still a relatively suitable setup especially for boys. In addition, the innovation and technology part: technology in everyday life; design and technical drawing; materials and processing; home economics (study groups are exchanged); project works (girls and boys together) works fine for both boys and girls.

The critical side of the study is that the study group consisted only from 11-13 year-old students. Although students' attitudes are assumed to be rather stable during the school years (Arffman & Brunell, 1983; Bjerrum Nielsen & Rudberg, 1989), Autio, Thorsteinsson and Olafsson (2012) found that there was significant statistical difference between 11 and 13 year old Finnish girls in attitudes towards technology. Furthermore, no statistical difference was found between younger and older Finnish and Icelandic boys or between Icelandic younger and older girls.

Another critical point of the empirical part was the use of a relatively small sample of students. However, 493 students seemed to be enough as the results are consistent with previous studies (Autio, 1997; Autio, Thorsteinsson & Olafsson, 2012; Autio & Soobik, 2013). In addition, the questionnaire measures only students' attitude, not their absolute technological will which is shaped and guided by human emotions, motivation, values and personal qualities. The concept attitude is just a single one part of a larger concept, which is 'technological competence'. Attitude is a crucial part of the competence as it depends on technological knowledge and technological skills in real life situations.

The reasons behind the dissimilarities found between the three countries may be due to differences in the curriculums and in different pedagogical traditions. On the other hand, the political situation has considerably changed in Estonia and the motivation for further development seems to be ambitious also in education, including the syllabi of craft and technology education. However, further research is needed before the authors can reach their final conclusions.

REFERENCES

- Ainevaldkond „Tehnoloogia“ (2011). [Subject field „Technology“]. (2011). RT I, 14.01.2011, 1. Retrieved from https://www.riigiteataja.ee/aktiiv/1200/9201/1009/VV1_lisa7.pdf.
- Arffman, I. & Brunell, V. (1983). *Sukupuolten psykologisista eroavaisuuksista ja niiden syistä [Psychological gender differences and the reasons for them]*. Jyväskylän yliopisto. Kasvatustieteiden tutkimuslaitoksen selosteita ja tiedotteita 283.
- Autio, O. (1997). *Oppilaiden teknisten valmiuksien kehittyminen peruskoulussa [Student's development in technical abilities in Finnish comprehensive school]*. Research Reports No. 117. Helsinki: The University of Helsinki, Department of Teacher Education.
- Autio, O., Thorsteinsson, G. & Olafsson, B. (2012). A Comparative Study of Finnish and Icelandic Craft Education Curriculums and Students' Attitudes towards Craft and Technology in Schools. *Procedia - Social and Behavioral Sciences* 45 (2012), 114-124.
- Autio, O. & Soobik, M. (2013). A Comparative Study of Craft and Technology Education Curriculums and Students' Attitudes towards Craft and Technology in Finnish and Estonian Schools. *Techne series A*, 20 (2), 17-33.
- Bjerrum Nielsen, H. & Rudberg, M. (1989). *Historien om jenter og gutter. Kjonnsosialisering i ett utveklingspsykologisk perspektiv*. Oslo: Universitetslaget.
- Dyrenfruth, M. J. (1990). Technological Literacy: Characteristics and Competencies, Revealed and Detailed. In H. Szydowski & R. Stryjski (Eds.) *Technology and School: Report of the PATT Conference* (pp. 26-50). Zielona Gora, Poland: Pedagogical University Press.
- Framework Curriculum Guidelines (2004). Helsinki: Opetushallitus.
- Layton, D. (1994). A School Subject in the Making? The Search for Fundamentals. In D. Layton (Ed.) *Innovations in Science and Technology Education* (Vol.5). Paris: Unesco.
- Olafsson, B. & Thorsteinsson, G. (2010). Examining Design and Craft Education in Iceland: Curriculum Development and Present Situation. *FORMakadmisk*, 3(2), 39-50.
- Raat, J. & de Vries, M. (1986). *What do Girls and Boys think about Technology?* Eindhoven, University of Technology.
- van der Velde, J. (1992). Technology in Basic Education. In Kananaja, T. (Ed.) *Technology Education Conference*. Helsinki: The National Board of Education (151-170).

YAN ALANI MATEMATİK ÖĞRETMENLİĞİ OLAN ÖĞRETMENLERİN MATEMATİK ÖĞRETİMİNE YÖNELİK GÖRÜŞLERİ

Tuba ADA

Selçuk ALKAN

Bu çalışma yan alanı matematik öğretmenliği olan fen bilgisi veya sınıf öğretmenliğinden matematik öğretmenliğine geçen öğretmenlerin matematik öğretimine yönelik görüşlerini belirlemek amacıyla yapılmıştır. Öğretmenlerin matematik eğitimi olgusunu araştırdığımız için çalışmada olgu bilim (fenomenoloji) araştırma deseni kullanılmıştır. Olgu bilim araştırma deseni derinlemesine bilgi sahibi olmadığımız olguları açığa çıkarmak amacıyla yapılmaktadır. Bu çalışmaya 5 öğretmen katılmıştır ve katılımcıların seçiminde amaçlı örnekleme yöntem türlerinden benzeşik örnekleme yöntemi kullanılmıştır. Öğretmenlerden üçü fen bilgisinden ikisi ise sınıf öğretmenliğinden matematik öğretmenliğine geçmiştir. Çalışmada veri toplamak amacıyla yarı yapılandırılmış görüşme formu kullanılmış ve görüşmeler ses kayıt cihazı ile toplanmıştır. Görüşmelerden sonra elde edilen bulgular tematik analiz kullanılarak çözümlenmiştir. Bu çalışma sonucunda fen bilgisinden geçiş yapan öğretmenlerin sınıf öğretmenlerine göre daha az sorun yaşadıkları özellikle alan bilgisinde kendilerini yeterli gördükleri ancak pedagojik alan bilgisinde özellikle de program bilgisinde yetersiz oldukları belirlenmiştir. Sınıf öğretmenlerinin ise kendilerini hem alan hem de pedagojik alan bilgisinde kendilerini yetersiz gördükleri sonucuna ulaşılmıştır.

Anahtar Kelimeler: Matematik öğretmenliği, matematik öğretimi

oooooooooooooooooooo

YAN ALANI MATEMATİK ÖĞRETMENLİĞİ OLAN ÖĞRETMENLERİN MATEMATİK ÖĞRETİMİNE YÖNELİK GÖRÜŞLERİ

Tuba ADA

Selçuk ALKAN

Bu çalışma yan alanı matematik öğretmenliği olan fen bilgisi veya sınıf öğretmenliğinden matematik öğretmenliğine geçen öğretmenlerin matematik öğretimine yönelik görüşlerini belirlemek amacıyla yapılmıştır. Öğretmenlerin matematik eğitimi olgusunu araştırdığımız için çalışmada olgu bilim (fenomenoloji) araştırma deseni kullanılmıştır. Olgu bilim araştırma deseni derinlemesine bilgi sahibi olmadığımız olguları açığa çıkarmak amacıyla yapılmaktadır. Bu çalışmaya 5 öğretmen katılmıştır ve katılımcıların seçiminde amaçlı örnekleme yöntem türlerinden benzeşik örnekleme yöntemi kullanılmıştır. Öğretmenlerden üçü fen bilgisinden ikisi ise sınıf öğretmenliğinden matematik öğretmenliğine geçmiştir. Çalışmada veri toplamak amacıyla yarı yapılandırılmış görüşme formu kullanılmış ve görüşmeler ses kayıt cihazı ile toplanmıştır. Görüşmelerden sonra elde edilen bulgular tematik analiz kullanılarak çözümlenmiştir. Bu çalışma sonucunda fen bilgisinden geçiş yapan öğretmenlerin sınıf öğretmenlerine göre daha az sorun yaşadıkları özellikle alan bilgisinde kendilerini yeterli gördükleri ancak pedagojik alan bilgisinde özellikle de program bilgisinde yetersiz oldukları belirlenmiştir. Sınıf öğretmenlerinin ise kendilerini hem alan hem de pedagojik alan bilgisinde kendilerini yetersiz gördükleri sonucuna

Keywords: mathematics teachers, math teaching

THE AWARENESS OF PRE-SERVICE TEACHERS ABOUT LIVING THINGS AS A FUNDAMENTAL CONCEPT ON TEACHING SOCIOSCIENTIFIC ISSUES

Adem TAŞDEMİR

Tezcan KARTAL

The pre-service teachers' acquisition levels are likely to have a direct effect on learning of students' concepts. Understanding the concepts in science and knowing the ways of concept learning and teaching provide invaluable knowledge and skills for teachers. Determining the students' levels of knowledge about the concepts and their misconceptions -if there are any - is very important. The opinions of pre-service teachers related to concept of living things and the relationship between independent variables were researched in this study. 384 pre-service teachers in Faculty of Education were taken as the study group which was composed randomly. To collect the data of this descriptive study, public survey was developed and performed by the researcher. As a result, pre-service teacher had misconceptions about living things. Pre-service teachers perceived animals as living things but they had difficulties to perceive plants as living. They were also observed that they feed living things for some reasons those are; interest, getting of stress and other family members' desire. On the other hand, training students weren't member of any organizations that try to protect living.

Keywords: Living things, living conscious, pre-service teachers.

PERCEPTIONS OF PRE-SERVICE TEACHERS ABOUT INSTRUCTIONAL TECHNOLOGY: THE FINDINGS OF A QUALITATIVE STUDY

Jacqueline T. MCDONNOUGH

Adem TAŞDEMİR

The use of technology is actively situated in all levels of society in line with the requirements of today's highly technological world. Rapid changes in technology have necessitated new approaches in education. Many research findings indicated that using instructional technology (IT) of in-service and pre-service teachers is significantly limited. This study aimed to investigate the perceptions of pre-service teachers about IT as it relates to their current and future use. Determining of pre-service teachers perception about IT could be provide evidence in order to more clearly identify the barriers. In this study, qualitative data were collected in two different ways. While the focus interview was used to describe pre-service teachers' perceptions in the first stage, researchers secondly used metaphor technique to identify their perceptions from a different perspective. The study sample was comprised of selected students from a graduate education program in a mid-sized Mid-Atlantic city in the United States with using a homogeneous sampling method. The study sample included 10 pre-service teachers for the focus group interview and 43 different pre-service teachers for the metaphor. The Results of study showed that although pre-service teachers had positive perceptions with using of IT in general, some of them had concerns about it. For example, some pre-service teachers directly focused on negative experiences with technology in their courses. They had a negative attitude about their instructors' technology use. In addition, most of them emphasized inefficiencies and limitations with online courses. But, both interview and metaphors showed that pre-service teachers mostly perceived IT as facilitating the learning and teaching process, reinforcement for teaching, and helped students learn. Also, pre-service teachers wanted to enroll in IT courses to contribute the teaching career, to become a better.

Keywords: INSTRUCTIONAL TECHNOLOGY, PERCEPTIONS, PRE-SERVICE TEACHERS.

THE ROLE OF BELIFS ON UNIVERSITY MATHEMATICS TEACHERS' PROFESSIONAL KNOWLEDGE DEVELOPMENT

Azimehsadat KHAKBAZ
azimehkhakbaz@ymail.com

This study aimed to explain the role of beliefs in university mathematics teachers' professional knowledge development. To this aim, a qualitative research was done. Data were gathered through phenomenological interviews with 27 mathematics university teachers in Iran and analyzed by coding and categorizing method. Analyzing data showed an explanation which included three main themes about beliefs: beliefs about the nature of mathematics, beliefs about mathematics teaching and learning and beliefs about professional teaching knowledge development. The first theme consists of three directions: mathematics as an abstract system, mathematics as tools and mathematics as a cultural coherent network. The second theme consists of two approaches: transmission of mathematics content and nurture of mathematics logic. The last theme included four orientations through professional teaching knowledge: inborn, experience without authority, skills and reflections.

Keywords: professional knowledge development, mathematics education, beliefs, higher education

INTRODUCTION

Professional knowledge development of teachers is an important subject in mathematics education research. Although we could find many research about this subject in school teaching, little is known in university teaching. This is because the context of school and university is completely different. University teachers or professors are hired and promoted because of their research success. They do not receive a curriculum about teaching knowledge development (Brogt, 2009). It seems that teaching in higher education is under the shadow of research (D' Andrea & Gosling, 2005). Meanwhile, mathematics university teachers or professors have a big influence on culture of mathematics education since they would teach mathematics to future mathematics teachers (Burton, 2004). Moreover, not only mathematics students in university level, but also many students in other disciplines are learning mathematics and all these persons would be parents, teachers and members of society who will influence on mathematics education for future generation. Therefore, mathematics professors' teaching knowledge development is highly influential but neglected.

On the other hand, to study in context of professional teaching knowledge, as Ernest (1989) asserted: "knowledge is important, but it alone is not enough to account for the differences between mathematics teachers" (p. 99). Nowadays, research in field of teachers' belief in mathematics education are more interesting, but there is little known about mathematics university teachers or professors' beliefs. They are mainly mathematicians so it seems we could not simply generalized research findings about mathematics teachers' belief from school level to university level. Therefore, the main question of this study is to explain how do different beliefs of university mathematics teachers influence professional teaching knowledge development?

To answer this question, it was essential to first clear our theoretical framework since both main aspects of this study (professional teaching knowledge development and beliefs) have rich literature. Many models and categorizations are known for both, each of which concentrate on these concepts through a different lens. This research tried to focus on professional teaching knowledge development through Shulman's (1986) introduction about pedagogical content knowledge (PCK) and also on beliefs through Ernest' s explanation (1989) which would be discussed more in the following sections of this paper.

Pedagogical content knowledge (PCK)

Pedagogical content knowledge first has introduced by Shulman (1985) as a "missing paradigm" in teaching research. In his next paper, Shulman (1986) divides content knowledge in to three parts: subject matter knowledge, pedagogical content knowledge and curricular knowledge. He explained that pedagogical content knowledge is subject matter specific for teaching. Afterwards he described PCK as a special amalgam of content and pedagogy that is uniquely the province of teachers, their own special form of professional understanding (Shulman, 1987)

The term of PCK is inherit Dewey's(1916-1964) that teachers must learn "psychologize" their subject matter for teaching to rethink disciplinary concepts and topics to make them more accessible to students (Counts, 1999). After introduction of PCK many researchers tried to work on that concepts. One of the most influential researchers was Grossman (1988) who introduced two overarching categories: General and Specific PCK. These categories were later modified by Fernandez-Balboa & Stiehl (1995) to generic and specific. Specific PCK is particular to instruction of a specific subject or content area; and Generic PCK is common to instruction all content areas or subjects. Generic PCK refers to the fact that every discipline in higher education could have a concept of PCK. It means mathematics as a discipline has its PCK and surely this Generic PCK consist of Specific PCK, emerged from different subjects and content area.

Grossman (1990) also described four categories embodied in PCK:

- Knowledge about the purposes for teaching a given subject matter (subject matter issue); •
- Knowledge about the students' understandings about the content (students issue); •
- Knowledge about the order in which subject matter should be presented (curricular issue); •
- Knowledge about the instructional strategies useful for teaching content (pedagogical issue). •

Counts (1999) asserted that in the development of PCK, the concept of formal and practical knowledge are well documented. Formal knowledge according to Lenze (1995) might be constructed in instructional workshop, graduate pedagogy course or prior undergraduate teacher education program. Practical knowledge comes from actual teaching in classroom (Grossman,1990).

Grossman (1988) suggest at least four possible sources for PCK which some of them caused formal knowledge development and the others resulted in practical knowledge development:

- Apprenticeship of observation: refers to observation of the class as a student (Practical Knowledge) •
- Disciplinary knowledge: refers to knowledge of subject matter being taught as well as related information (Formal Knowledge) •
- Professional coursework: can help teachers make necessary translation from disciplinary understanding of subject matter to a more pedagogical understanding of subject matter (Formal Knowledge) •
- Teaching experiences: provide the opportunity for future teachers to test the knowledge they have acquired from other sources (Practical Knowledge). •

On the other hand as PCK is an academic concept for explanation of teaching, it has some limitations. Studies about PCK revealed that PCK does not consider about beliefs and values and it seems values are "missing part of the missing paradigm" (Gudmundsdottir, 1990). Shulman(1992) asserted that he forgot that important part and he referred to Fenstermacher (1992) who believed that when we talk about teaching, we should consider both manner and method.

Teachers' beliefs

Research on teachers' beliefs, emotions, attitudes, and affect has vastly increased during the last two decades. These terms, however, are not used in a uniform way in mathematics education. As Philipp (2007) defined beliefs are described as "Psychologically held understandings, premises, or propositions about the world that are thought to be true... Beliefs, unlike knowledge, may be held with various degrees of conviction" (p. 259). One of the main basic models about teachers' beliefs belongs to Ernest (1989) who explained the key belief components of the mathematics teacher are the teacher's:

- View or conception of the nature of mathematics; •
- Model or view of the of the nature of mathematics teaching; •
- Model or view of the process of learning mathematics. •

The teacher's conception of the nature of mathematics, is his or her belief system concerning the nature of mathematics as a whole. Three kinds of beliefs are distinguished through Ernest (1989) categorization which are rooted in the philosophy of mathematics and science.

- Instrumentalist view: that mathematics is an accumulation of facts, rules and skills to be used in the pursuance of some external end. Thus mathematics is a set of unrelated but utilitarian rules and facts. •
- Platonist view of mathematics as a static but unified body of certain knowledge. Mathematics is discovered, not created. •
- Problem solving view of mathematics as a dynamic, continually expanding field of human creation and invention, a cultural product. Mathematics is a process of enquiry and coming to know, not a finished product, for its results remain open to revision. •

The model of teaching mathematics is the teacher's conception of the type and range of teaching roles, actions and classroom activities associated with the teaching of mathematics. Many contributing constructs can be specified including unique versus multiple approaches to tasks, and individual versus cooperative teaching approaches. Three different models which can be specified through the teacher's role and intended outcome of instruction are:

- Instructors: skills mastery with correct performance; •
- Explainer: conceptual understanding with unified knowledge; •
- Facilitator: confident problem posing and solving. •

The use of curricular materials in mathematics is also of central, importance in a model of teaching. Three patterns of use are:

- The strict following of a text or scheme; •
- Modification of the textbook approach, enriched with additional problems and activities; •
- Teacher or school construction of the mathematics curriculum. •

Closely associated with the above is the teacher's mental model of the learning of mathematics. This consists of the teacher's view of the process of learning mathematics, what behaviors and mental activities are involved on the part of the learner, and what constitute appropriate and prototypical learning activities. Two of the key constructs for these models are: learning as active construction, as opposed to the passive reception of knowledge; the development of autonomy and child interests in mathematics, versus a view of the learner as submissive and compliant. Using these key constructs the following simplified models can be sketched, based on the child's:

- compliant behavior and mastery of skills model; •
- reception of knowledge model; •
- active construction of understanding model; •
- exploration and autonomous pursuit of own interests model. •

METHODS

This research has done in qualitative research paradigm. Data gathered mainly through semi structured phenomenological interviews about experiences of teaching and learning mathematics in university. Respondents were 19 PhD students and 8 professors in mathematics discipline who were selected from 2 universities in Iran. They were selected in pure and applied mathematics and also mathematics education. They were on a experience spectrum from juniors to seniors both in students and professors. The process of selection of respondents and gathering data from them was continued until the saturation has happened in findings from data analysis.

Data were analyzed through coding and making theme as Creswell (2008) has described in his book. The analysis had two levels. In the first level, themes which explained PCK for teaching mathematics in universities were found. On the other hand, it was found out that respondents used different resources and methods to develop their PCK for teaching mathematics at university. The second level of analysis tried to find out how beliefs of respondents influenced first level and caused different respondents showed different elements of PCK and develop it through special way by special methods and resources. The second level of analysis is what we used to answer the question of the present paper and would be explained in the following section.

RESULTS AND FINDINGS

Data analysis showed there are three main categorizes beliefs which influence on university teachers' professional teaching knowledge development:

- Beliefs about the nature of mathematics; •
- Beliefs about mathematics teaching and learning; •
- Beliefs about professional teaching knowledge development. •

Beliefs about the nature of mathematics

One of the essential beliefs influences PCK development was beliefs about the nature of mathematics. This theme itself consists of three directions:

Mathematics as an abstract system: In this direction, existed participants who look at mathematics as an external abstract result. One of them explained:

It needs patience to work with mathematics because we are working in a world which is not real...nothing is real in this world... everything is imagination and solitary. We want to survive in this world and try to make relationship between elements of this world.

The other one said:

We do not have pure mathematics and applied mathematics. Mathematics is just a discipline of abstract world and some parts of this world have applications for other worlds or real world.

The persons who are in this direction, usually teach mathematics as an abstract text. They engage students with theorem and proofs.

Mathematics as tools: In contrary with the above direction, there are university teachers who believed mathematics as a tool in the life or other sciences. One of the respondents explained:

Mathematics is alive because of its applications. If you do not have any application for a subject in mathematics, it will be disappear soon. So it is important for students to know the application of a subject which you intended to teach them.

The teachers in this direction usually engage their students with explanation of applications of a subject in mathematics, in real world or other sciences. For example, teachers who teach in economy or accounting discipline would try to explain the applications of mathematics in economy or accounting.

Mathematics as a cultural coherent network: Some of the respondents of this research who were in minority believed mathematics as a cultural coherent network. One of them said:

In my point of view, mathematics as something which some people are doing it, has its own history. Each mathematical concept has a humanistic conceptual history.

The people in this direction teach mathematics through its history and evolution of concepts. One of the participants explained:

I believe mathematics as a discipline with connected concepts. I believe in applications of mathematics concepts but not in other sciences or real world, but in mathematics itself.

Beliefs about mathematics teaching and learning

The second kinds of beliefs which is founded is beliefs about mathematics teaching and learning. This theme consists of two main approaches:

Transmission of mathematics content: In this approach mathematics professor put his main aim of education based on transmission of mathematics content. He thinks his duty is to transfer and his students duty is to receive mathematical concept. In this approach, content is based and learners are observers. However, observer may be active or inactive and professor may just transfer the content in a solid atmosphere or motivate students to learn that, but priority is with covering and conveying content. One of the participants in this research explained:

I made a plan for covering content during the semester. Each session I know the limitation of my teaching. Then I try to make my teaching interesting by cooperating students in teaching, for example put some parts of teaching for them to make conference or make some problems to solve.

The other one said:

Students should know that you know more than them. If they know that, they would listen to your teaching and you could finish the rubric.

As explained above the first professor makes students active while second professor makes them inactive, but both of them believe in covering the content.

Nurture of mathematics logic: In contrary with the following approach, professors in this approach believed the aim of mathematics education is to nurture mathematics logic. One of the participants of this research explained:

My aim of teaching mathematics is to help students to learn logical thinking and problem solving. This is more important than learning mathematical concepts. If they learn logical thinking and problem solving, they will learn all mathematical concepts....learning the soul of mathematics is important, I think.

In this approach we have found two other trends: those professors who implement their role as a responsible guide which have the more responsibility and try to cooperate students with them and those professors who implement as facilitators of learning who put the responsibility of learning mainly on students shoulders, trust and let them to move in the way of learning and they would follow them to help if students would need.

One of the professors who has the responsible guide role in teaching and learning process said:

When I am teaching, I always ask my students what they think now? What is the next step? I want to make them to think. It is better than I just teach some realities without making opportunities for them to think and reflect.

The other participant who has the facilitator role explained:

I start my teaching with the place that students are and they are the person who lead the process of teaching. I have in my mind the heart of subject of a course but they are really students who define the limitations of that and I just try to help them to make the details of each mathematical concept.

Beliefs about professional teaching knowledge development

The last category of beliefs in this research refers to beliefs about professional teaching knowledge development. Four orientations under this category are found:

Professional teaching knowledge as inborn: Some of the participants of this research believed that good teachers are inborn good teachers or they have talent of good teaching. They do not think that teachers could develop their teaching knowledge.

Professional teaching knowledge as experience without authority: In contrary with the above group, some of the respondents of this research referred that teaching knowledge could be developed but through experience. They believed that experienced teachers could teach better than new teachers and new teachers should wait to the time that they would be experienced and that time they are good teachers.

Professional teaching knowledge as skills: Majority of the participants of this research believed that they could be good teachers by learning how to teach through external resources like books, workshops, courses, receiving advice of good teachers and by experiencing. They think teaching is kind of skill that they could obtain that through some procedures.

Professional teaching knowledge as reflections: Minority of participant of this research believed development of teaching knowledge as a reflective activity. Similar to the previous group, they think knowledge of teaching could be developed, but it is not something as skills. They think teachers would create this kind of knowledge through reflection before, in and on their action.

CONCLUSION

PCK is an interdisciplinary knowledge in nature which integrate from two main elements: content (hear mathematics) and pedagogy. Therefore beliefs about mathematics and pedagogy of mathematics influence PCK. On the other hand, we wanted to study in context PCK development so beliefs about professional teaching knowledge itself would be influential. Through analysis of data in this study, it is concluded that different beliefs of university mathematics teachers influenced their PCK development as explained. Therefore PCK development is not a value-free concept and this study has provided an explanation for this claim.

RECOMMENDATION

Through results of this study, theoretical and practical recommendations is made. Practically, it is recommended to consider beliefs of mathematics professors in designing curriculum for PCK development in mathematics. Theoretically, it is recommended to find out beliefs of mathematics university teachers in other cultural contexts and try to enrich the theoretical categorization.

REFERENCES

Brog, E. (2009). **Pedagogical and curricular thinking of professional astronomers teaching the Hertzsprung- Russell diagram in introductory astronomy courses for non-science major.** Unpublished PhD dissertation of the University of Arizona.

- Burton, L. (2004). **Mathematicians as enquirers**. *Mathematics Education Library*. Kluwer Academic Publisher.
- Creswell, J. W. (2008). **Educational research**. Pearson Education International.
- Counts, M. C. **A case study of a college physics professor's pedagogical content knowledge**. PhD dissertation of the Gorgia State University.
- D'Andrea, V. & Gosling, D. (2005). **Improving teaching and learning in higher education**. Open University Press.
- Dewey, J. (1902). **The child and the curriculum**. The University of Chicago Press.
- Ernest, P. (1989). **The knowledge, beliefs and attitudes of the mathematics teacher: A model**. *Journal of Education for Teaching*, 15, Pp 13-33.
- Fernandez-Balboa, J. & Stiehl, J. (1995). **The generic of pedagogical content knowledge among college professors**. *Teaching and Teacher Education*. 11(3). 293-306.
- Grossman, P. L. (1988). **A study in contrast: Sources of pedagogical content knowledge for secondary English**. PhD dissertation, Stanford University, Stanford, CA.
- Grossman, P. L. (1990). **The making of a teacher: Teacher knowledge and teacher education**. New York: Teachers College Press.
- Gudmundsdottir, S. (1990). **Values in pedagogical content knowledge**. *Journal of Teacher Education*, 41(3), Pp 44-52.
- Lenze, L.(1995). **The pedagogical content knowledge of faculty relatively new to college teaching**. PhD dissertation of the Graduate School, Illinois.
- Shulman, L.S. (1986). **Those who understand: Knowledge growth in teaching**. *Educational Researcher*, 15(2). 4-14.
- Shulman, L. S. (1987). **Knowledge and teaching: Foundations of the new reform**. *Harvard Educational Review*, 57. 1-22.
- Shulman, L. S. (1992). **Research on teaching: A historical and personal perspective**. In Oser, F. K. ,Dick, A. & Pattry, J. *Effective and responsible teaching*. The Jossy-Bass Education Series. Pp 14-31.

TURKISH CHEMISTRY TEACHERS' VIEWS ABOUT SECONDARY SCHOOL CHEMISTRY CURRICULUM: A PERSPECTIVE FROM ENVIRONMENTAL EDUCATION

Ömer Faruk İÇÖZ
Middle East Technical University
faruk.icoz@metu.edu.tr

ABSTRACT: Teachers' views about environmental education (EE) have been regarded as one of the most important concerns in education for sustainability. In secondary school chemistry curriculum, there are several subjects about EE embedded in the chemistry subjects in Turkey. This study explores three chemistry teachers' views about to what extent the subjects related with EE should be integrated into secondary school chemistry curriculum at an individual level of analysis. The findings of the study indicate that there is a consensus among teachers on the inadequacy of secondary school chemistry curriculum for providing students an effective EE. However, there is an inconsiderable divergence among the teachers' views about the placement of subjects about EE in chemistry curriculum and the integration of subjects about EE into the curriculum. Through the results of the study, policy makers and curriculum developers would gain a comprehensive insight about deficiencies in chemistry curriculum for EE from the point of view of chemistry teachers and they would have opportunity to realize the ways for the remedy of this deficiency.

Key words: environmental education, chemistry curriculum

CONTEXT

It is clear for all mankind that the decline in the vitality of the planet is almost everywhere, which mainly results from population growth, industrial discharges, consumption patterns, solid wastes disposal, and domestic wastewater discharges, etc. However, we still have the chance to recover this tendency in declining through taking the necessary precautions before it is too late. Therefore, EE takes its place as one of the key means of reacting in the face of environmental threats (Teksoz, Sahin, & Ertepinar, 2010).

Environmental education can be defined in a general view as the education process dealing with humankind's relationship with the natural and human-made surroundings, and includes the relation of population, pollution, resource allocation and depletion, conservation, transportation, technology, economic impact and urban and rural planning to the total human environment (Peterson, 2007). Thus, the concept EE involves knowledge and comprehension about ecological, social and political processes and their influences (Bartuseviča, Cēdere, & Andersone, 2004). In Tbilisi Declaration which was created in the first Intergovernmental Conference on Environmental Education, the goals of EE stated as (1) to foster clear awareness of, and concern about, economic, social, political, and ecological, interdependence in urban and rural areas; (2) to provide every person with opportunities to acquire the knowledge, values, attitudes, commitment, and skills needed to protect and improve the environment; (3) to create new patterns of behavior of individuals, groups, and society as a whole towards the environment (UNESCO, 1977). The Tbilisi Declaration has been used as a grounding document to outline what EE is and how it should be taught in various contexts.

There are many advantageous aspects of EE. The teachers perceived that EE was not only a way to teach about the environment, but also an innovative way to achieve basic educational goals like reading and student skills. Besides becoming more aware of the environment and environmental issues, students would learn to care about the environment and appreciate nature, students would learn of their impact on the environment, and students would realize their responsibility for the earth (Middlestadt, Ledsky, & Sanchack, 1999).

Environmental education has a wide extent ranging from environmental pollution (water pollution, air pollution, soil pollution, noise pollution, solid wastes, and hazardous wastes), global warming (climate change), environmental cycles (C, H₂O and N₂ cycles), biodiversity, energy usage, health education, to resolution of environmental problems (recycling, renewable energy sources, population and environment) (Teksoz, Sahin, & Ertepinar, 2010). EE subjects are interdisciplinary in nature, thus the extent to which discipline-oriented teachers are able to deal with interdisciplinary subjects is the limiting factor for introducing environmental issues as an integral part of the science curriculum (Gough, 2002). The issues within the scope of EE should be integrated into the curriculum of all the natural sciences because the environmental issues are not separate from problems of chemistry, physics and biology (Bartuseviča, Cēdere, & Andersone, 2004). In addition, the issues related to

EE should be in the core of science curriculum. According to Edelson (2007), the reasons why the issues related to EE should be included in the core of secondary school science curriculum are (i) they are important for students and society; (ii) they are representative of contemporary science in ways that the disciplinary courses that currently comprise the core curriculum are not; (iii) they create an opportunity for students to experience an applied science; (iv) they are particularly engaging context for learning fundamental science. Implementation of EE in secondary school depends on both school curricula and teachers' environmental competencies.

Integrating the issues related EE into secondary school chemistry curriculum would be an effective means in order to come over the problem of discrepancy between the chemistry curriculum and the information necessary for life in modern society and to gain students a meaningful mode of chemical thinking and understanding attitude towards environmental processes and skills which are useful for practical life (Feiarebend, Jokmin, & Eilks, 2010). Therefore, in secondary school chemistry curriculum, an approach that establishes a joint between chemistry and environmental issues should be adopted by curriculum designers. Moreover, many researchers have suggested that teaching chemistry in the context of real-world issues as a way that motivates and interests students (Hofstein, Eilks, & Bybee, 2011; Holbrook & Rannikmae, 2007, 2009; Marks & Eilks, 2009, 2010). Thus, integrating more environmental issues in chemistry curriculum would provide students a better understanding about the relation of chemistry with daily-life. According to the findings of the study of Mandler, Mamlok-Naaman, Blonder, Yayon, and Hofstein, (2012) using more environmental examples in teaching chemistry increase students' awareness towards environmental issues, especially issues that are connected to their everyday lives and students see chemistry as a way of better understanding and as a better way of solving environmental problems. Moreover, a five-year evaluation report on Chemistry in the Community (ChemCom) which was published in 1992 concluded that students wanted to learn chemistry through environmental contexts (Sutman & Bruce, 1992).

According to the literature, there is a clear consensus among researchers about integrating environmental issues in science curriculum in general and in chemistry curriculum in particular (Edelson, 2007; Ernst, 2007; Hofstein, Eilks, & Bybee, 2011; Holbrook & Rannikmae, 2007, 2009; Liberman & Hoody, 1998; Marks & Eilks, 2009, 2010; Sutman & Bruce, 1992). In the last decade many studies have been conducted about the integration of EE in science education and implementation of EE in secondary schools (American Chemical Society, 2006; Benett & Lubben, 2006; Hofstein & Kesner, 2006). However, in science education literature there has not been any study that directly studies on the extent to which subjects related with EE should be integrated into science or chemistry curriculum. This study aims to fill this gap in the literature. The purpose of this study is to explore Turkish chemistry teachers' views about to what extent the subjects related with EE should be integrated into secondary school chemistry curriculum at an individual level of analysis. The findings of this study would be mainly important for curriculum designers and policy makers on the account of the fact that it reflects chemistry teachers'-as implementers of curriculum- views about how and to what extent EE can be embedded into chemistry curriculum. Through the findings of this study, policy makers and curriculum developers would have opportunity to comprehend and realize what the deficiencies are in chemistry curriculum and problems in implication of the curriculum for conveying EE in chemistry. The research question of this study is "To what extent the subjects related with EE should be integrated into secondary school chemistry curriculum according to Turkish chemistry teachers?" and the sub research questions used in this study are as follows:

- (1) To what extent, do chemistry teachers regard the chemistry curriculum including subjects for environmental education?
- (2) According to the chemistry teachers, which subjects about EE should be added on or removed from the secondary school chemistry curriculum and what are the reasons for those additions or removals?
- (3) According to the chemistry teachers, what should be the placements of the subjects about EE in chemistry subjects in secondary school chemistry curriculum and what are the reasons for those placements?

THE STUDY

The case-study approach was chosen as a research method in the study due to its robust grounding in reality, accessibility to teachers and its ability to generate a detailed and rich narrative. Generalization takes the form of 'theoretical inference' in which the conclusions move beyond the individual cases to a more general and a theoretical level (Hammersley, 1998).

Participants

The findings presented in this paper are based on detailed interviews undertaken with three experienced chemistry teachers, Sevil, Enis and Ersin in three secondary schools located in different cities in Turkey as a part of research. Table 1 provides some brief biographical details about the participants involved. Each participant has been working in different cities in Turkey. All of the participants have never before taken any courses on EE in their undergraduate education and they also have not attended any in-service training about environmental education.

Table 1. Details of Research Participants

	Teacher 1: Sevil	Teacher 2: Enis	Teacher 3: Ersin
Years Teaching	8	11	12
Gender	Female	Male	Male
School Type	Public	Private	Public
School Size	1000	500	1200
School Situation	Urban	Urban	Urban
Age	33	35	37

Data Collection

The researcher conducted semi-structured interviews with experienced chemistry teachers for the purpose of gathering information directly from participants' mind. One-on-one interviews were conducted by telephone by using open-ended interview questions in Table 2. Therefore, the response modes used in the interview was unstructured. Each interview lasted for about 30 minutes and interview protocols were used during the interviews.

Table 2. Interview Questions in Relation to the Research Questions

Interview Questions	Relation to the Research Question
To what extent is chemistry curriculum related to environmental education?	1 st research question
In chemistry curriculum which subjects include topics related to environmental education?	1 st research question
<i>Are they adequate for an effective environmental education?</i>	1 st research question
<i>Do you emphasize sufficiently on those subjects?</i>	1 st research question
Which of the following environmental issues should be in the chemistry curriculum? Why? a. Water pollution b. Solid wastes c. Hazardous wastes d. Global warming e. Air pollution f. Loss of biological diversity g. Consumption patterns h. Deforestation i. Noise pollution j. Soil pollution k. Population and environment l. Environmental cycles (C, H ₂ O and N ₂ cycles) m. Energy usage	2 nd research question
<i>In which chemistry subjects should those be integrated?</i>	2 nd research question
Beyond the scope of current chemistry curriculum, are there any environmental issues which are discussed in the class?	2 nd research question

<i>If yes, in which chemistry subjects should those subjects be taught? Why?</i>	3 rd research question
Do you think that environmental education should be a separate must course rather than being in chemistry curriculum? Why?	3 rd research question

Analysis of Data

The Turkish secondary school chemistry curriculum was investigated in detail and related to EE the aims and the subject matters were listed in order to validate what the interviewees stated about the curriculum and the curriculum itself. During the interviews, I checked whether interviewees' statements matched up with the curriculum or not and the issues which were not overlapped were questioned to clarify whether the interviewees omitted those issues in the lessons or forgot to state to the interviewer. Moreover, in order to validate the accuracy of findings, I got feedback from participants about the final reports about the interviews. All participants affirmed the reports without a disagreement. Furthermore, an expert scholar in the field reviewed and asked questions about the study from beginning to the end.

FINDINGS

The study revealed a remarkable degree of similarity among the views of the three chemistry teachers on the inadequacy of chemistry curriculum for providing students an effective EE. Moreover, data from all chemistry teachers suggest that subjects related to EE were not taught appropriately in the lessons. However, despite their apparent agreement about inadequacy of chemistry curriculum, the picture which emerged from detailed analysis of the interview data showed that there is a disagreement about the integration of EE subjects into the chemistry curriculum and proper placements of those subjects in the chemistry curriculum.

To what extent, do chemistry teachers regard the chemistry curriculum including subjects for environmental education?

All of the teachers agreed that the chemistry curriculum was inadequate for providing students an effective EE and the chemistry curriculum did not treat environmental subjects in a wide coverage:

I think our curriculum doesn't include subjects related with environmental issues, its relation to EE is superficial and narrow-scoped, and also it's not sufficient to develop students an understanding about environmental issues. (Sevil)

The chemistry curriculum doesn't mention a lot about the importance of environment and the effects of people's behaviours on environment ... and although chemistry is very closely related to environment, the curriculum doesn't give chance for an effective environmental education. (Ersin)

Moreover, all teachers similarly stated that existing subjects related to EE were not taught appropriately due to several reasons which were the time allocated for those subjects, the placement of those subjects in the curriculum and technical reasons in that teachers could not test some subjects as they were taught after the final examination of the semester:

There are only two subjects related with environmental education that I focus in lessons. One of them is a separate unit titled as 'Chemistry in Life'. It's the last unit of ninth grade chemistry course ... I can't teach the unit in detail as it's taught after the final exam of the semester. The other one is taught as a short part in the 'Radioactivity' unit. Here, the only focus is on the effect of radioactivity on living things ... These two subjects aren't adequate of course for a good environmental education. (Enis)

The specified lesson hours in the curriculum for subjects related with EE are so few that it's impossible to provide students an understanding about environment and to gain them an environmental perspective... (Ersin)

The only unit that wholly allocated to environmental issues is "Chemistry in Life". This is the last unit of the ninth graders and because students become tired and remain indifferent toward all lessons,

they can't learn it efficiently. If this unit hadn't been at the end of the second semester of the year, it'd probably have been more effective in terms of EE. (Sevil)

According to the chemistry teachers, which subjects about EE should be added on or removed from the secondary school chemistry curriculum and what are the reasons for those additions or removals?

There was a disagreement among teachers' views on inclusion of subjects which were related to EE in chemistry curriculum. One of the teachers (Sevil) proposed that all the subjects within the scope of EE should be in the chemistry curriculum and a comprehensive integration of EE and chemistry should be established in order to provide an effective EE claiming that chemistry is the most suitable branch of science for realization of that purpose:

Because EE subjects are more relevant to chemistry rather than other branches of science, it should be the main platform to teach environmental issues. Moreover, all of the other branches of science should include subjects related EE as well as chemistry. ... As all of the subjects of EE are closely related to chemistry, they can be taught in chemistry lessons except a few such as biological diversity and noise pollution. (Sevil)

On the contrary, the other two teachers (Ersin and Enis) suggested that some subjects related to EE should be immersed in chemistry curriculum to a certain extent. Water, soil and air pollution, consumption patterns energy usage, and climate change should be involved in the chemistry curriculum. However, they opposed EE subjects to be included in the core of chemistry curriculum due to the fact that chemistry subjects may face the danger of being undervalued and omitted in the curriculum:

It's not possible for chemistry curriculum to cover all the environmental issues but environmental pollution and consumption patterns may be involved in the curriculum due to their importance for our life. We use up our water resources by using chemicals such as detergents and fertilizers. ... Beyond the scope of curriculum, in lessons, sometimes students ask about consumption patterns and their effects on environment, and we talk over the issue. ... I want my students be more aware students of environmental issues and I want to teach them some subjects about environmental issues but I'm a chemistry teacher in the first place. (Enis)

Some subjects about EE should be taught by immersing in chemistry subjects such as water pollution, solid wastes and global warming ... If the curriculum included all the subjects in the scope of environmental education, how we would achieve to teach chemistry in detail. ... Will it be a chemistry lesson or an environmental chemistry lesson? (Ersin)

According to the chemistry teachers, what should be the placements of the subjects about EE in chemistry subjects in secondary school chemistry curriculum and what are the reasons for those placements?

There was not an agreement among teachers' views on both placement of the subjects related EE in the chemistry curriculum and how to teach EE subjects; through integrating chemistry course or as a separate course on EE. On the one hand, Ersin and Enis had the idea of teaching EE subjects as a separate course; on the other hand Sevil suggested that the EE subjects should be integrated into chemistry curriculum rather than being taught as a separate course for a better understanding:

EE subjects should be taught together with chemistry subjects, in this way students will understand the scientific background of the issues and chemistry will be a more enjoyable lesson for the students. (Sevil)

The ideas of teachers about the placements of subjects in the scope of EE into chemistry subjects are shown in Table 3.

Table 3. Placement of Subjects of EE into Chemistry Subjects

Subjects Related to EE	Chemistry Subjects according to Teachers		
	Teacher 1: Sevil	Teacher 2: Ersin	Teacher 3: Enis

Water Pollution	Compounds & Solutions	Solutions	Compounds & Solutions
Solid Wastes	Chemical Reactions	Chemical Reactions	-
Hazardous Wastes	Compounds & Radioactivity	Compounds / Electrochemistry	-
Global Warming	Gaseous State	-	-
Air Pollution	Gaseous State	Gaseous State	Gaseous State
Loss of Biological Diversity	-	-	-
Consumption Patterns	Organic Chemistry	-	Compounds & Chemical Reactions
Deforestation	Organic Chemistry	-	-
Noise Pollution	-	-	-
Soil Pollution	Solutions	Compounds & Periodic Table	Compounds & Solutions
Population and Environment	-	-	-
Environmental Cycles	Gaseous State	-	-
Energy Usage	Energy in Chemical Reactions	Energy in Chemical Reactions	-

DISCUSSION AND CONCLUSION

This study confines itself to interviewing three chemistry teachers working in high schools. The scope of the study is narrowed by secondary school chemistry curriculum and its approach to environmental education. Furthermore, affective domains such as chemistry teachers' attitudes, self-efficacy beliefs, or motivations toward environmental issues are beyond the scope of this study. On the other hand, the limited number of participants can be seen as a potential weakness for the study. However, due to the fact that participants are quite experienced and they have been in the field as the implementers of the curriculum, the findings of the study can be regarded as quite valuable and significant.

In Turkey EE is still not a part of the core secondary school chemistry curriculum and adopted curriculum does not provide a means for an effective EE and what is worse, it includes only a few subjects related with environmental education. Generally these subjects even were not taught appropriately by chemistry teachers due to some reasons such as insufficiency of amount of time allocated for those subjects and the placements of those subjects in the curriculum. Although there is not a consensus about teachers on the integration of EE subjects into chemistry curriculum, previous researches indicate that through integrating EE in chemistry, students may gain a meaningful mode of chemical thinking and understanding attitude towards environmental processes and skills (Feiarebend, Jokmin, & Eilks, 2010; Hofstein, Eilks, & Bybee, 2011). Thus, curriculum designers and policy makers should take necessary measures according to the findings of the study owing to the importance of environmental education; the subjects for EE should be immersed and integrated in secondary school chemistry curriculum urgently. In order to realize this, in-service teachers should be trained on EE by Ministry of Education, and in chemistry departments of education faculties, there should be at least one undergraduate must course about environmental education.

For further researches, quantitative studies can be conducted to reveal the deficiency and the needs in chemistry curriculum from EE perspective and to assess the competence of chemistry teachers in EE. Further analysis may also reveal the differences between the Turkish curriculum and those of other countries' from the point of chemistry teachers' views through an environmental perspective.

REFERENCES

- American Chemical Society (2006). *Chemistry in the community: ChemCom* (6th ed.), New York, NY: Freeman.
- Bartuseviča, A., Cēdere, D., & Andersons, R. (2004). Assessment of the environmental aspect in a contemporary teaching/learning model of chemistry in basic schools of Latvia. *Journal of Baltic Science Education*, 2 (6), 43-51.
- Benett J., & Lubben F. (2006). Context-based chemistry: The Salters approach. *International Journal of Science Education*, 28, 999–1015.
- Edelson, D. C. (2007). Environmental Science for All? Considering Environmental Science for Inclusion in the High School Core Curriculum. *Science Educator*, 16 (1), 42-56.
- Ernst, J. (2007). Factors associated with K-12 teachers' use of environment-based education. *Journal of Environmental Education*, 38(3) 15-32.
- Feierabend, T., Jokmin, S., & Eilks, I. (2011). Chemistry teachers' view of teaching 'climate change' – an interview case study from research-oriented learning in teacher education. *Chemistry Education Research and Practice*, 12, 85-91.
- Gough, A. (2002). Mutualism: A different agenda for environmental science education. *International Journal of Science Education*, 24, 1201-1215.
- Hofstein A., Eilks I., & Bybee R. (2011). Societal issues and their importance for contemporary science education: A pedagogical justification and the state-of-the-art in Israel, Germany and the USA. *International Journal of Science and Mathematics Education*, 9, 1459–1483.
- Hammersley, M. (1998). *Reading Ethnographic Research: A critical guide*. 2nd edition. London: Longman.
- Hofstein A., & Kesner M. (2006). Industrial chemistry and school chemistry: Making chemistry studies more relevant. *International Journal of Science Education*, 28, 1017–1039.
- Holbrook J., & Rannikmae M. (2007). The nature of science education for enhancing scientific literacy. *International Journal of Science Education*, 29, 1347–1362.
- Holbrook J., & Rannikmae M. (2009). The meaning of scientific literacy. *International Journal of Environmental and Science Education*, 4, 275–288.
- Lieberman, G.A., & Hoody, L.L. (1998). *Closing the Achievement Gap: Using the Environment as an Integrating Context for Learning*. San Diego, CA. State Education and Environment Roundtable.
- Mandler, D., Mamlok-Naaman, R., Blonder, R., Yayon, M., & Hofstein, A. (2012). High-school chemistry teaching through environmentally oriented curricula. *Chemistry Education Research and Practice*, 13, 90-92.
- Marks R., & Eilks I. (2009). Promoting scientific literacy using a sociocritical and problem-oriented approach to chemistry teaching: Concept, examples, and experiences. *International Journal of Environmental and Science Education*, 4, 231–245.
- Marks R., & Eilks I. (2010). Research-based development of a lesson plan on shower gels and musk fragrances following a socio-critical and problem-oriented approach to chemistry teaching. *Chemistry Education Research and Practice*, 11, 129–141.
- Middlestadt, S. E., Ledsky, R., & Sanchack, J. (1999). *Elementary school teachers' beliefs about teaching environmental education*. Rock Spring, Georgia: NAAEE.
- Peterson, T. A. (2007). Definition of environmental education from the environmental education act of 1970, March, 2013. Retrieve at <http://www.lbl.org/ADMIN/environedstratplanfinal.pdf>
- Sutman, F., & Bruce, M. (1992). Chemistry in the community – ChemCom: A five-year evaluation. *Journal of Chemical Education*, 69, 564–567.
- Teksoz, G., Sahin, E., & Ertepinar, H. (2010). A new vision for chemistry education students: Environmental education. *International Journal of Environmental and Science Education* 5(2) 131-149.
- UNESCO, UNEP (1977). Intergovernmental conference on environmental education organized by UNESCO in co-operation with UNEP (Tbilisi, USSR, 14-26 October 1977) Final report. New York: UNIPUB. Retrieve at <http://unesdoc.unesco.org/images/0003/000327/032763eo.pdf>

APPLICATION FOR TRACKING STUDENTS' EFFICIENCY AND PREDICTING EXPECTATIONS BASED ON CURRENT RESULTS

Srdja BJELADINOVIC
Faculty of Organizational Sciences, University of Belgrade
srdja.bjeladinovic@gmail.com

Sonja ISLJAMOVIC
Faculty of Organizational Sciences, University of Belgrade
sonjaisljamovic@gmail.com

ABSTRACT: Globalization and technological development are radically changing the landscape of higher education. Students increasingly expect to choose what they learn, how they learn and when they learn, according to their individual needs and interests. Computer applications in education system introduce unique technical, managerial and most importantly pedagogical issues. Using business discovery platform QlikView, application developed in this research, should be beneficial to both, students and professors at the university. The relation database model is based on data collected from student admission service of Faculty of Organizational Science, University of Belgrade. Application allows students to analyze current study success, but also to predict future performance success. In addition, students can use developed application as an advisor system, which can be useful in helping student plan for the upcoming semesters and also to be able to answer any questions that the student may have regarding his/her academic standing.

Keywords: knowledge-based application, student study success, higher education

INTRODUCTION

The use of modern technological resources and teaching aids, as well as the adjustment of teaching content to students, in order to achieve better results in the adoption and application of knowledge, may represent a good basis for the development of contemporary concepts of education in the 21st century. In order to achieve this, it is necessary to detect, define and analyze existing patterns of behavior and students' learning. Today, there are a large number of software products for facilitating and improving the quality of learning. Some of them are intended for students of primary schools and high schools, while the other are focused on college students. Exactly the last mentioned type of software represents interest of this paper.

In this paper, the introductory part will present related works and background of the methodology in area of educational administration software. The basic concepts of QlikView software platform and developed Academic Dashboard for Faculty of Organizational Sciences, University of Belgrade will be analyzed in the central part of the paper. The final part of the paper defines the guidelines for further development and adaptation of higher education system to the necessities of a student.

METHODOLOGY AND TECHNOLOGY SUPPORT

Methodology background and related works

Technological development has provided base for developing software with new functionality. Teaching process records constant improvement through the use of ICT (Arenas-Marquez et al, 2012). Nowadays, providing students with services they expect is more challenging than ever before. Some of those services are ability to track current students' achievements and results, planning next semester, conducting optimal selection of exams based on preferences and results, operational planning, like attending colloquia, exams, participations in projects and practices etc. Also, that kind of software is attended for professors in order to track effectiveness of students (individually, by teams or by generation) and for planning and adapting exams curriculum in order to meet future interest of students. Some of those are open source (Coll et al., 2008) and others are vendors' solutions. Software scope and architecture may vary and below is an overview of the most significant solutions.

IBM company provides personalized software package SPSS for students and teachers. This software integrates different types of data analysis, data mining trend research and quantitative methods for measuring efficiency. Students can plan obligations, track and analyze exams' results, use tools for advising etc(IBM, 2014). Beside this software, students can customize and use IBM's BI tool, named Cognos. Because of its complexity and

detailed analysis, usage of SPSS or Cognos can be demanding and difficult, especially from a student point of view.

SAP offers solution to support the work of students and teachers. Integral parts of this software are: Student Lifecycle Management, Teaching and Learning, Learner achievement Measurement and Tracking and Educational Performance Analytics (SAP, 2014). This software is a feature-rich, both for the students' and teachers' work. Student can plan and monitor present liabilities in the current semester, monitor different statistics of their past achievements and use adviser in order to get proposal of exams in subsequent semesters, use distance learning etc. Moreover, students can run "what-if" scenarios to view requirements for a program being considered, including courses adequate for transfer if they changed programs. Mentioned software allows professors to plan classes and the necessary resources (personnel, classrooms, technical resources), to monitor the presence of students (status of their obligations, progress, rating), to define grade scale, to evaluate test in-time and to send test results to students, to propose future courses based on interest of students, to optimize study process and to carry out large number of statistical analyzes.

Microsoft offers multiple solutions to support students and teachers by personalizing product from the Dynamics family or using dedicated software like: Communication and Collaboration, Device Management, Web Portals, E-learning and Tracking Institutional effectiveness for Higher Education. These software solutions allow quick and easy connection and communication between students and teachers through various types of devices, easy scheduling obligations both students and teachers in accordance with number of registered students, retention of various records. Using this software, teachers can easily perform different analysis, support online teaching, testing and decision-making. Also, all of mentioned software solutions are easy to integrate with other Microsoft's products (Microsoft, 2014).

In addition to the mentioned software there are some open source solution (qOrganizer, Planbook, StudentLife, TeachersPlanner, and StudyMinder). Characteristic of all listed open sources software solutions are that they allows only a slight adjustment to a specific software system and essentially real system needs to adapt to software requirements (called personalization process). This paper will present how to develop custom applications based on both existing data, collected from student admission service of Faculty of Organizational Science (University of Belgrade) and the required functionality. Technology used for this solution is QlikView.

QlikView technology

QlikView represents new patented software engine, which compresses data and holds it in memory, where it is available for immediate exploration by multiple users. QlikView delivers an associative experience across all the data used for analysis, regardless of where it is stored, (Harmsen, 2012). For datasets too large to fit in memory, QlikView connects directly to the data source and generates new views of data on the fly. QlikView's patented core technology, associative experience, and collaboration and mobile capabilities, make able to work with a lot of questions, passing by traditional hierarchical models, with created an associative network which works similar to human brain. Empowering the information workforce to derive insights from data helps organizations streamline, simplify, and optimize decision making, (Harmsen, 2012).

In primary frontend-backend architecture, on which is based QlikView solution, as data layer (Infrastructure resource) will be used relational database to record data on students of the Faculty of Organizational Sciences. Using OLDB connections, QlikView server will establish communication with the database with students data within specific time intervals (monthly level or after completion of the exam period). Once the connection between QlikView and elementary student database is established, the application will use the Associative Query Language (AQL) to download data from the relevant tables, necessary for the operating and usage, and after that it will be stored in its own memory. In addition to downloading data, backend part of application will be provided with ability to define application logic, rules for establishing a link between the data (in accordance with already defined relational model), as well as methods and privileges for using the application. Within the frontend, according to the rights they have, each user will be able to access the application and review it available reports and data.

STRUCTURE OF DATA MODEL AND APPLICATION

Similar to QlikView usage in public or private sector, we developed QlikView Academic Dashboard for Faculty of Organizational Sciences, University of Belgrade, in order to help educational professionals and students to maximize data governance and optimize their intellectual investments by discovering how QlikView is used at a granular level in educational sector. With this application and resulting knowledge, professors and students can

introduce more manageable and repeatable educational processes, as well as address data lineage and impact analysis questions on more efficient way. Approach of developing an integrated system for students and teachers has considerable benefits for improved data quality, mainly due to the fact that integration obviates the need for complex interfaces(Berkhoff et al., 2012).

The data contained within this application represents student personal, demographic and academic data, collected from student admission service of Faculty of Organizational Science, University of Belgrade. Using this data we can analyze the demographic and socio-economic student structure and success at the University. Developed relation data base model consists of 15 objects and more than 50 attributes.

Using the student grade data, an academic advisor can guide the student as to which classes still need to be fulfilled before graduation or how to improve current GPA (grade point average). Professors will be able to monitor students' achiness and success by each study program, student gender, finished high school, exam, semester or science filed. Application allow students to analyze current study success, but also to predict future success performance based on average exam performance from other students whit same background. Students in addition can use developed application as an advisor system, this data is useful in helping students plan for the upcoming semesters and also to be able to answer any questions that the student may have regarding his/her academic standing. This application, also, takes advantage of security level setup using section access to show different views of the data, including two basic views: a professor view and a single student view.

RESULTS AND FINDINGS

Professor View for Academic Dashboard for Faculty of Organizational Sciences

Academic Dashboard for Faculty of Organizational Sciences allows professor and administrative staff to view a breakdown of demographic data such as gender, ethnicity, class standing and province of residence. Using these data fields they can identify trends and also can get an overall picture of the demographic breakdown of the faculty and students.

Teaching staff will be able to monitor success of students in each of the courses for which they are responsible. Data for each subject will be available in different time units: specific examination period, semester, school year, calendar year etc. Teachers will be provided with option for tracking students' success on multiple courses, for example group of courses for which a particular teacher is in charge. As it shown in Figure 1, professors can keep an eye on data such as GPA, average study length, entrance exam points by country, region and high school type for each generation of students. That kind of observing students' success can be of great significance in determining trends in college enrollment.

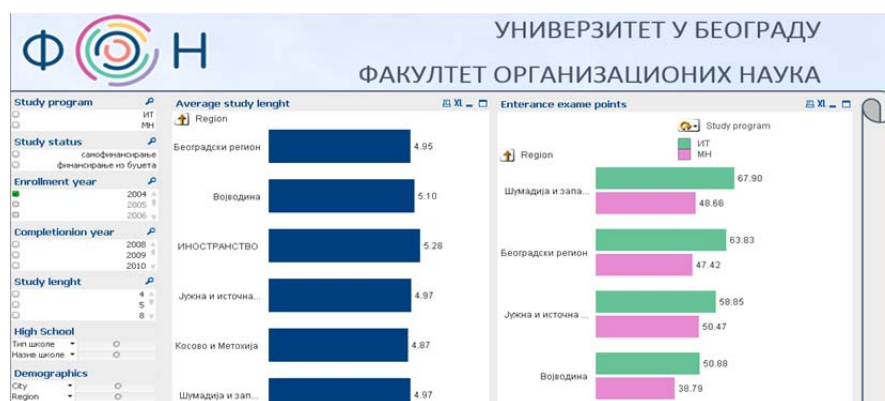

Figure 1. Students' success by Region

In order to identify, for example, gender structure and study success, on each study program by different success criteria, on both global (GPA, average study length, average entrance exam points) and individual (exam, semester, specific examination period) level, just by selecting adequate view, time period and desired variable, as it shown on Figure 2. Professor can switch to a chart view of GPA and see the disbursement of current GPAs on student, course or exam level, and with that like organized data, professors can look for trends in GPAs and get a high-level view of how our students are performing. Selecting from the list boxes on the left they can filter the data down to a particular major and/or course.



Figure 2. Detailed success statistic by student gender

Observing student profile a professor or educational office staff, as administrator, can see the academic data for any of the students enrolled in the faculty. Once the administrator identifies a single student, he/she can then get a look into that student's current academic state on more detailed level. Data such as cumulative GPA, declared major and minor, courses taken, remaining courses needed to fulfillment major requirement, and address information. As an advisor, this data is useful in helping the student plan for the upcoming semesters and also to be able answer any questions that the student may have regarding his/her academic standing. Through continuous monitoring of students during their studies, at an early stage, teachers can perceive students with good potential and students who need extra help in order to improve their results. The best students can be offered extra activities, for example additional courses, participation in scientific research and projects.

Student View for Academic Dashboard for Faculty of Organizational Sciences

Through interactive forms (and with adequate data security mechanism), students of the Faculty will be provided with the ability to monitor continuously their progress during the study (number of exams, grades etc.), as well as their ranking relative to other students from the same generation and on the same study program, as it is presented on Figure 3. This functionality commonly gives extra value for quality assurance processes in higher education (Seghedin). After completing the first year of undergraduate studies, using the application, students will be able to review the predicted potential success at the end of the study, which is certainly a good indicator and a guideline for further technical and scientific development.

Another important benefit of this software represent fact that it is provided as SaaS(Software-as-a-Service), which is defacto increasingly important paradigm in information technology and also provides education systems as a service for enhancing processes in higher education (Masud & Huang, 2013). This functionality enables students with an easy-to-use application, for which utilization they only need web browser and permitted access to application.



Figure 3. Students' success on individual level

The Student View shows a single student's academic data. Additionally, students can also use the "What-If" scenario to allow the student to hypothetically change his/her major and see the immediate impact that decision would have on the required courses necessary to fulfill the major requirements. Also, students will have ability to compare personal results (GPA or special exam grade) with success of other student in a class or with students with same demographic characteristics.

CONCLUSION

System model for recording and monitoring study performance, presented in this paper, can be used as a good basis for improving the process of higher education. The developed system aims to provide teachers with tracking functionality in order for continuously monitor students' achievements. Also, application allows them to compare students' success categorized by courses, science-education groups or exams periods. Based on these information professors can determine the patterns of students' aspirations and needs, which can directly improve the process of education.

In addition to relations that indicate dependency between of students and their success, the developed system (based on QlikView in- memory solution) allows as well identification of relationships that are not directly related to the success in studies. Example for previous would be possibility for linking student with list of elective courses and optional seminars, that they have chosen. This possibility provides students with advisory tool for choosing courses in the following semesters, gives guidelines for further scientific and professional development of each individual and also contributes to the prediction of the expected popularity of the elective subjects in the future.

Directions for future research are further improvement of the system in terms of development of modules for prediction students success and for their positioning and ranking among other students in their generation.

REFERENCES

- Arenas-Marquez, F.J., & Machuca, J.A.D., & Medina-Lopez, C. (2012). Interactive learning in operations management higher education Software design and experimental evaluation, *International Journal Of Operations & Production Management*, 32(12), 1395-1426.
- Berkhoff, K., & Ebeling, B., & Lubbe, S. (2012). Integrating research information into a software for higher education administration - benefits for data quality and accessibility, *E-Infrastructures For Research And Innovation: Linking Information Systems To Improve Scientific Knowledge Production*, 167-176.
- Coll, H., & Bri, D., & Garcia, M., & Lloret, J. (2008). Free software and open source applications in higher education. *New Aspects Of Engineering Education*, 325-330.
- Harmsen, B. (2012). *QlikView 11 for Developers*, Packt Publishing.
- IBM. (2014). Institutional SPSS software, link: <http://www-03.ibm.com/software/products/en/spss-stats-gradpack>, last accessed: april 2014.
- Masud, M.A.H., & Huang, X.D. (2013). ESaaS: A New Software Paradigm for Supporting Higher Education in Cloud Environment. *Proceedings Of The 2013 Ieee 17th International Conference On Computer Supported Cooperative Work In Design (Cscwd)*, 196-201.
- Microsoft. (2014). Institutional Effectiveness For Higher Education, link: <http://www.microsoft.com/education/ww/solutions/Pages/institutional-effectiveness.aspx>, last accessed: april 2014.
- SAP. (2014). *Executive Overview Higher Education and Research*, SAP AG.
- Seghedini, N.E., & Chitariu, D. (2013). Software Application For The Development Of Quality Culture In Higher Education, *eLearning & Software for Education*, 3, 338-343.

SEKİZİNCİ SINIF ÖĞRENCİLERİNİN HİSTOGRAM GRAFİĞİNİ OLUŞTURMA, YORUMLAMA VE ANLAMLANDIRMA SÜRECİNE İLİŞKİN BİR DURUM ÇALIŞMASI

A CASE STUDY OF EIGHTH GRADE STUDENTS RELATING TO HISTOGRAM CHART CREATING, INTERPRETATION AND THEIR SENSE-MAKING PROCESS

Nadide YILMAZ
Hacettepe Üniversitesi
nadideylmz@hacettepe.edu.tr

Sonay POLAT AY
Hacettepe Üniversitesi
zsp@hacettepe.edu.tr

ÖZET: Bir durum çalışması olarak yapılandırılan bu araştırmada sekizinci sınıf öğrencilerinin histogram oluşturma, yorumlama süreci ve sütun grafiği ile karşılaştırma sürecindeki bilişsel durumları incelenmiştir. Araştırmanın teorik alt yapısını Mooney'in (2002) karakterize ettiği istatistiksel düşünme seviyeleri oluşturmuştur. Çalışmaya Ankara ili Polatlı ilçesinde yer alan bir devlet okulunda öğrenim gören altı sekizinci sınıf öğrenci katılmıştır. Çalışmanın verileri yarı yapılandırılmış görüşmeler ile toplanmıştır. Görüşme soruları alanında uzman dört kişi tarafından incelenmiş ve pilot çalışması yapıldıktan sonra son haline getirilmiştir. Her bir öğrenciyle yapılan görüşmeler 40-60 dk arasında sürmüştür ve ses kayıt cihazı ile kaydedilmiştir. Öğrencilerin verdikleri cevaplar analiz edildiğinde histogram oluşturma ve yorumlama sürecinde bazı sıkıntıların olduğu ortaya çıkmıştır. Sürekli ve süreksiz verileri ayırt etme konusunda sıkıntı yaşayan öğrencilerin histograma ilişkin kavramsal bilgilerinde eksikliklerin olduğu belirlenmiştir. Ayrıca öğrencilerin sütun grafiği ile histogram arasındaki en temel kavramsal farkları ayırt etmekte zorlandıkları ortaya çıkmıştır. Araştırmanın tüm bulguları ve ortaya çıkan birtakım eksiklerin giderilmesi için ortaya konacak öneriler detaylı bir biçimde sunum sırasında paylaşılacaktır.

Anahtar sözcükler: histogram, sekizinci sınıf öğrencileri, istatistiksel düşünme

ABSTRACT: In this case study a comparison between the eighth grade students creation and interpretation of a histogram and a bar chart was made. During this comparison the cognitive status was examined. The theoretical background of this research is inspired by Mooney's (2002) characterized levels of statistical thinking. This study was done with the participation of six eighth grade students in Ankara/Polatlı. Data was collected through semi-structured interviews. The interview questions were examined by four experts within the field and were finalized after the pilot study was made. Each interview with the students were between 40-60 minutes long and were recorded with a tape recorder. When the students answer's were analyzed, some difficulties appeared during the process of their creation and interpretation of the histogram. It has been identified that the students who have difficulties in distinguishing continuous and discontinuous data have a lack of conceptual knowledge related to histogram. In addition it has emerged that the students have difficulties in distinguishing the most basic conceptual differences between bar chart and histogram. All of the research findings and the recommendations how to overcome the deficiencies that has emerged will be shared in details during the presentation.

Key words: histogram, eighth grade students, statistical thinking

A REVIEW OF CRITERIA FOR CONTENT SELECTION IN PRIMARY EDUCATION CURRICULUM. (IN IRAN)

Ghahraman MADADLOU
Lecturer in Farhangian University and PhD Student of Curriculum Development
madadlou@quran.ac.ir

Khadijeh Rasulli GHARAAINI
Ministry of Education Teacher

ABSTRACT: Content as an element of the curriculum plays a very important role in achieving the goals of education in society and is viewed as a key element in all approaches and perspectives. In view of the importance of content in curriculum decision-making, different criteria and measures have been offered by experts for its selection and development. This article was aimed at reviewing and analyzing these criteria and measures along with providing a set of practical criteria to select curriculum content in primary education. In this paper, after analyzing the content of books and articles available, criteria for content selection based on scientific principles of curriculum development was presented under three categories as consolidated content criteria. In philosophical criteria, appropriateness of content with the values and goals, scientific disciplines, and valid knowledge, in psychological criteria, overall growth including physical growth, etc., attention to specific learning problems, interests and talents, and the needs of learners, in social and cultural criteria, cultural heritage, issues and needs of the local and national community, ethnic and cultural characteristics and appropriateness with global issues and communications, and in economic criteria, fitness of content with the facilities available in the school and the region, appropriateness of content with the budget and operating costs have been recognized and presented as criteria for the appropriateness of content selection.

Keywords: Content, Content Selection, Curriculum Principles

INTRODUCTION

The problem and the aim of this paper are to pay attention to the importance of content and the criteria for its selection in curriculum planning, particularly in elementary course, and providing integrative criteria based on the qualities of learners and the structure of society. Therefore, by integrating the present criteria and paying attention to the scientific principles of curriculum planning, particularly economic principles, to which there has been no attention paid in the books or essays, we can present some criteria. The main question of this paper is that whether we can present some criteria according to the present criteria and the scientific principles of curriculum planning which are undoubtedly effective in choosing and developing the content. Therefore, to present a number of integrative criteria in choosing the content, first, a list of present books concerning the subject were extracted and then, according to the present criteria in the books, lack of attention to this subject made us analyze the introduced criteria in many books and essays so that we could introduce a number of comprehensive criteria to develop the content of curriculums.

To reach the goal of this study and to present it to a number of criteria for choosing the content, we chose the following three books as samples according to the fact that to choose these three sources, there was much emphasis on the criteria in selection. These books include *Principles and Concepts of Curriculum* by Fathi Vajargah, *Curriculum Development: Practice Guide* by Hasan Maleki and *Procedures and Revisions in Curriculum Development* by the experts in the center for international scientific studies and collaboration of Ministry of Education. This study was performed in a review form and a comparative way and finally, considering the different views and contemplating the scientific principles of this field of study, some criteria were presented according to philosophical, social, psychological and economic principles.

THE CONCEPT OF CURRICULUM

In this section, to enlighten the place and the importance of curriculum as well as its elements, particularly the element of content, some views and definitions are explained.

Eisner (1994), a leading curriculum theorist, believes that the origin of the word "curriculum" lies in the Latin word "currere" which means race or running course. He also believes that the elements of curriculum include

aim, content, various opportunities of learning, organizing the content, the style of presentation, answering and evaluation.

The origin of the word “curriculum” is from the Latin root of “Race course” and has its roots in a course of action or the distance which needs to be travelled to reach the intended goal. According to Zeiss, the elements of curriculum include aim, content, learning activities and evaluation methods. (FathiVajargah, 2009, p. 14: Zeiss)

Using a simile between a race course and the curriculum in both of the above-mentioned views explains the two qualities attributed to curriculum. (Mehrmohammadi, 2011, p.11) First, like race courses which have definite starting and ending points, curriculums require beginnings, endings and definite and predetermined routes. The second discernible quality of the word “curriculum”, based on its root, is that as there are obstacles in the way of course runners which make it difficult for them to proceed, the curriculums gradually get more difficult too. This issue is clearly evident in students' textbooks that the selection of content and the way it's organized can cause its difficulty.

The word “curriculum” which most of translators and experts have equalized with “curriculum development”, was common in the past, but recently, it's translated as just “curriculum” since “curriculum development” is just one aspect of curriculum as a field of study and the only controller of planning process is “curriculum development” itself. (Mehrmohammadi, 2011, p. 11)

There are so many different definitions of curriculum according to different views and patterns of curriculum as a field of study. But what is important is that the definition must be comprehensive and logical. According to the present definitions of curriculum which are many in number, the most exact and comprehensive definition is that of Mr. Maleki's (2008) which is an average definition of the others: curriculum refers to formal and informal contents, content process and overt and covert instructions through which the learner gains the required knowledge, acquires the skills and changes his values and tendencies under the expert guidance of school.

According to Klein (1991), the elements of curriculum include aims, content, teaching strategies, learning, materials and resources of learning activities, methods of evaluation, the grouping of learners and time and place. (FathiVajargah, 2009, p. 129) Evaluation of other scholar's views (Ash, 1991), (Beauchamp, 1982), (Stark and Lattuca, 1997) concerning the elements of curriculum show that most of the views focus on its content and place among the elements of curriculum and regard them as the main and indispensable elements.

The reason for profusion of definitions of curriculum in field of education is different interpretations of the word “curriculum” itself and different views in field of curriculum.

CONTENT

After prioritizing learners' needs and choosing the goals, the content of curriculum is another element which needs to be chosen, designed and developed. The first step to achieve the goals is the selection of suitable educational content. (Maleki, 2008, p. 47) Therefore, in order to choose the suitable content and present the appropriate criteria for its development, we need to know the content. There are so many different definitions of content which some of them are as follows:

The content of curriculum refers to particular facts, opinions, principles and issues which are included in a particular subject matter. (Connelly & Lantz, 1991)

The content of a subject matter includes organized knowledge, terms, information, facts, rules, principles, methods, concepts, decisions, phenomena and the issues related to the same subject matter. (Ghoorchian, 1995)

To select the content, its subject matter and goals need to be determined so that we can choose the suitable content based on the goals and related subject. For instance, if our subject is empirical science education and the aim of empirical science education is to familiarize the students with different types of rocks, the content of curriculum can be chosen in written or oral form (FathiVajargah, 2009, p. 172) or in practical form, that is to say, the course concepts are explained on an excursion so it is called an observational or practical content by providing learning opportunities.

According to the fact that the content is an effective element in the process of curriculum development and its significance due to the qualities of learners in elementary course, particular criteria need to be considered in the selection of curriculum content. These criteria are different due to difference in perspectives and this paper aims to examine some of these samples and finally, some criteria for the selection of curriculum content in elementary course will be presented.

Discussing the criteria for the selection of content, most of the researchers in this field of study have emphasized on the importance of “Proportion” criteria. (Fathi, 2004, p. 122) These criteria, which have been included in *The Principles of Curriculum Development* by FathiVajargah (pp 123-127), are as follows:

1. The proportion between the content and the social factors and values
 - 1.1 The proportion between the content and culture, ideals and social expectations
 - 1.2 The proportion between the content and scientific and technological advances
 - 1.3 The proportion between the content and issues and needs of national and practical society
 - 1.4 The proportion between the content and global issues and relations
2. The proportion between the content and the learners' qualities and needs
 - 2.1 The proportion between the content and the students' abilities and learning talents
 - 2.2 The proportion between the content and the students' needs and
 - 2.3 The proportion between the content and the students' real lives
 - 2.4 The content needs to provide the context for the experiences and the future learning of students
3. The proportion between the content and the lawfulness of curriculum
 - 3.1 Content balance
 - 3.2 Content coherence

In his book, *Curriculum Development: Practice Guide* (2008, pp 116-118), Mr. Hassan Maleki introduces the following criteria for the selection of content:

1. Importance (the importance of content for solving the problems of life, enhancing the learners' subject knowledge, etc.)
2. Validity (accuracy and validity of concepts, principles and generalizations)
3. Interest (the learners should take an interest in their learning)
4. Usefulness (useful function of content)
5. Learning ability (the content should be intelligible for the learners and it needs to be within the limits of their own experiences)
6. Flexibility (selection according to time, resources, staff, political climate, etc.)
7. Attention to knowledge structure
8. Full attention to protection and promulgation of cultural heritage and value system
9. Improving the scientific level of students for constant and self-directed education
10. Contact with life, everyday experience and current issues
11. Providing good opportunities for activities and multiple learning skills

“*Procedures and Revisions in Curriculum Development*” (2001, p. 121) written by the experts in the center for international scientific studies and collaboration of Ministry of Education, presents the following items for the selection of content:

1. For the selection of content, we need to scrutinize the structure of curriculum. Therefore to do so:
 - A set of basic concepts to describe the issues and phenomena should be determined within the limits of a subject matter.
 - A method, in which the stored knowledge in that subject matter is organized, should be determined.
 - A set of methods and basic rules which provide the required evidence in a subject matter, that is to say, the particular method of scientific researches should be determined. Since every field of study is seeking for a particular knowledge, it is clearly evident that a particular method is used to find out the accuracy of its findings.
2. We need to provide an accurate list of key concepts and basic skills in that particular subject matter and then they should be divided into groups.
3. The list of content culture, key concepts and basic skills should be selected according to the following principles:
 - It should pay attention to protection and promulgation of cultural heritage and value system.
 - An example of the latest fundamental, scientific and artistic information of that particular subject matter should be reflected in the list.
 - It should be a basis for constant and self-directed education.
 - It should be directly in contact with life, everyday experiences and current issues.
 - It should be regarded as a good opportunity for multiple educational activities and skills.
 - It should provide the context for international relationships.

INTEGRATIVE CRITERIA FOR CONTENT SELECTION

According to the importance of curriculum principles in curriculum development and selection of its elements and considering the qualities of elementary students, the criteria for the selection of curriculum content were based on scientific principles. Using various classifications which were developed from the criteria for content selection, the following criteria presented in the forms of integrative criteria for the use of curriculum designers are recommended. It is worth mentioning that this classification is presented as follows based on scientific principles of curriculum, i.e. philosophical, sociocultural, psychological, economic and political principles:

The proportion between the content and economic principles

It seems that in countries suffering from economic problems, addressing the issues concerning economic principles in designing the curriculum, particularly costly contents such as providing teaching and learning opportunities, experiment and workshop, research and excursion, performing costly scientific and practical works and attention to economic principles of curriculum, is necessary. (Parvand, 2008, p. 88) It's because sometimes so many interesting contents in different forms are produced for curriculums. But due to financial problems or since the schools cannot afford to execute the content, the execution of the plan confronts a lot of problems. In this issue, addressing the following items can be regarded as the appropriate criteria of economic principles. Since in the world today, the youth education is a sort of national investment and each country which is endeavoring more in this way shall enjoy more economic and social advancements in the future. (Emadzadeh, 2006, p. 33)

Education enhances the people's production and service capacity. Education has got economic benefits and investment in it will make people, their families and society benefit from its positive values. (ibid, p. 107) Therefore, according to the economic importance of education and the central role of the content in order to realize the goals of education as well as the importance of financial issues, expenditure and facilities In terms of quantity and quality in implementation and achievement of curriculum goals, the inclusion of economic principles in development and selection of content is necessary. The criteria for the proportion between the content and the scientific principles of curriculum are as follows:

The proportion between the content and economic principles:

- The proportion between the content and facilities like workshop, laboratory, etc. in the area and school
- The proportion between the content and allocated budget to the area or school
- The proportion between the content and administrative costs

The proportion between the content and philosophical principle of curriculum:

- Attention to ideological values in selection of content
- The proportion between the content and the goals of curriculum
- The proportion between the content and valid scientific fields of study

The proportion between the content and social and cultural principles:

- Attention to culture and cultural heritage in selection of content
- Attention to problems and needs of national and local society
- The proportion between the content and global issues and relations

The proportion between the content and psychological principles:

- Attention to physical, mental and emotional growth in selection of content
- Attention to learners' specific learning problems and difficulties
- Attention to interests and talents
- Attention to the learners' needs

REFERENCES

- FathiVajargah, K.(2009). The Principle and the Concepts of Curriculum Development. Tehran: Bal Publications.
- Mehrmohammadi, M.(2011). The Curriculum and its relationship with the Other Fields of Educational Science. Mashhad: BehNashr Publications.

Maleki, H. (2008). Curriculum Development: Practice Guide. Tehran: Madreseh Publications,.

Ghoorchian, N.G.(1995). The appearance of the procedure of curriculum changes. Tehran: Institute for Research and Planning in Higher Education.

Experts in the Center for International Scientific Studies and Collaboration of Ministry of Education. Procedures and Revisions in Curriculum Development.(2000). Tehran: Ministry of Education.

Parvand, M. H.(1999). Preparations for Educational Planning. Tehran: DonyayePajooresh Publications.

Emadzadeh, M.(2006). Economics of Education. Isfahan: ACECR.

GENEL LİSE ÖĞRENCİLERİNİN FATİH PROJESİNİN KULLANIM DÜZEYİNE İLİŞKİN GÖRÜŞLERİ (ANTALYA İLİ MURATPAŞA İLÇESİ ÖRNEĞİ)

GENERAL HIGH SCHOOL STUDENTS' OPINIONS ON THE USAGE LEVEL OF THE PROJECT FATİH (THE CASE OF MURATPAŞA DISTRICT OF ANTALYA PROVINCE)

İlhan GÜNBAI
Akdeniz Üniversitesi
igunbayi@akdeniz.edu.tr

Tayfun YÖRÜK
Akdeniz Üniversitesi
t.yoruk@gmail.com

ÖZET: Bu çalışmada, resmi ve genel liselerde öğrencilerin 2012 - 2013 eğitim öğretim yılında uygulamaya koyulan FATİH Projesi'nin kullanım düzeyine ilişkin görüşleri belirlenmeye çalışılmıştır. Çalışmada tarama modeli kullanılmış olup araştırmanın örneklemini 2012 - 2013 eğitim öğretim yılında Antalya ili Muratpaşa ilçesinde bulunan ve FATİH Projesinin uygulanmakta olduğu 16 genel lisede öğrenim görmekte olan 375 öğrenci oluşturmaktadır. Anket çözümlenmeleri için SPSS 18.0, LISREL 8.54 programlarından yararlanılarak, frekans, yüzde, aritmetik ortalama, standart sapma, t-Testi, LSD ve tek yönlü varyans analizi testleri kullanılmıştır. Araştırmadan elde edilen bulgulara göre öğrenciler, Eğitimde FATİH Projesi kullanım düzeylerine ilişkin olarak e-içerik kullanımı, eğitim gereksinimi ve kurum yeterliği boyutlarında “orta”; öğretim süreçleri, öz-yeterlik ve proje getirileri boyutlarında “yüksek” düzeyde olumlu görüşe sahiptir.

Anahtar Sözcükler: FATİH Projesi, Öğrenci Görüşleri

ABSTRACT: In this study, general high school students' opinions on the usage level of the Project FATİH were tried to be determined. Survey model was used in this research and the research's sample consists of 375 students who were selected using random method. Data collected from surveys were analysed by software SPSS 18.0 and LISREL 8.54. In the analyse process, frequency (f), percentage (%), mean (), standard deviation (SD), t-Test, LSD and One Way ANOVA tests were used. Findings show that students have high level of opinion on the factors “Progress of Instruction” and “Self-Efficacy and The Returns of The Project”, while they have moderate opinions on the factors “The Use of E-Content”, “Requirement for Education”, “Adequacy of The Institution”.

Keywords: the Project FATİH, Students Opinions

GİRİŞ

Kökene itibari ile Yunanca “teknik” kelimesinden gelen ve dilbilgisi karşılığında teknik ile ilgili bilim anlamında olan teknolojiyi, bilimin somutlaşmış biçimi şeklinde tanımlamak mümkündür. (Işık, 1981:159, Alkan, Deryakulu, Şimşek, 1995:81). Teknolojinin en yoğun uygulandığı alan eğitim alanıdır. Birçok otorite tarafından teknoloji ve eğitimde yaşanacak bütünleştirme ile öğrenme ortamlarından materyallerine kadar bütün süreçler daha verimli olacak, sonuç olarak da daha nitelikli bireyler yetişecektir. (İnel, Evrekli, Balım, 2011:129). Aggarwal (2000)'a göre 21. yüzyıl eğitimi yerden ve zamandan bağımsız, amaç ve sonuca doğru yönelimli, öğrenci merkezli, aktif takım çalışması ağırlıklı, öğrenim elde etmeye yöneliktir, beceri ve dildeki farklılıkları barındırmaktadır (Yılmaz ve Horzum, 2005:110). Bu nedenle bu noktada eğitim teknolojisi kavramından söz etmek yerinde olacaktır. Alkan (1997) eğitim teknolojisinin tanımına ilişkin olarak, “eğitimin yürütülmesine ilişkin süreçlerle ilişkili olup, davranışları saptama, eğitim durumlarını belirleme ve yaşantıları kazandırma etkinlikleriyle ilgili olarak ortamı düzenleme ya da çevreyi ayarlama etkinlikleridir” ifadesiyle süreç, eğitim ortamı ve çevre arasındaki ilişkiyi eğitim teknolojisi bağlamında açıklamıştır. Toplum, toplumu oluşturan bireyler ve bilgi kendini sürekli yenilemekte dolayısıyla eğitimin de güncelleştirilmesi gerekmektedir. Bu güncelleştirme aşamasında eğitimin kendine özgü ortamları ve teknolojilerinin neler olduğu, eğitim ve öğretimde gerçekleştirilmesi gereken hedeflerin etkili biçimde hangi yollarla gerçekleştirileceği sorularının cevaplanması eğitim teknolojilerinin uğraşısı kapsamındadır (Numanoğlu, 1995:67).

Konuya ilişkin olarak alanyazında dikkati, eğitim süreçlerine teknoloji entegrasyonunun nasıl ve ne kadar sağlandığı noktalarına çeken araştırmalar da mevcuttur. Hew ve Brush (2007) bu bütünleşmenin zorunluluğunu vurgulamış ancak okullarda böyle bir bütünleşmenin kesin bir tanımının olamayacağı fikrini savunmuşlardır. Ajjan ve Hartshorne (2008) ise internet teknolojisi ve kelime işlemci-hesaplama tablosu gibi masaüstü yazılım programlarının okullarda masaüstü bilgisayarlar ya da dizüstü bilgisayarlarda eğitim amaçlı olarak kullanımını teknoloji entegrasyonunun göstergesi olarak kabul etmişlerdir. Cuban, Kirkpatrick ve Peck(2001) bu bütünleşmenin yüksek veya düşük seviyede olabileceğini ortaya koymuşlardır. Çalışmalarına göre, düşük seviye teknoloji entegrasyonu kapsamına öğrencilerin okullarda internette araştırma gibi yalnızca basit kullanımları, yüksek seviyede teknoloji entegrasyonu kapsamına ise öğrencilerin çoklu ortam sunumları yapmaları, projeler için veri toplamaları ve açıklamaları girmektedir. Elektronik dünyasında yaşanan hızlı gelişmelerin sonucu olarak bilgisayarların yaşantımızda yer almasıyla birlikte günümüz teknolojisi ile bilgisayarların neredeyse eş anlamda kullanıldığına şahit olmaktayız. Bilgisayarların bir öğrenme-öğretme aracı şeklindeki kullanımı, diğer hizmetlerde kullanılmasından daha fazla önem taşımaktadır. Çünkü eğitim teknolojisinin temel işlevi öğrenme-öğretme süreçlerinin daha verimli ve etkili olmasını sağlamaktır. Akpınar ve arkadaşlarına göre (2005) eğitim, yıllarca öğretmenin sıkı kontrolünde gerçekleşmiş, öğretmen her zaman bilgiyi aktarmıştır. Öğrenci bilgiyi oluşturma sürecinde birincil sırayı almasıyla birlikte öğretmenin rolü de değişmiş, bilginin oluşturulması sürecinde yardım eden konumuna gelmiştir. Bilgisayar destekli öğretim ise, öğretim sürecinde bilgisayarın bir seçenek olarak değil, sistemi tamamlayıcı, sistemi güçlendirici bir etmen olarak kullanılmasıdır (Uşun, 2004:40, Bayturan, 2008:11).

Günümüze gelindiğinde MEB tarafından uygulamaya koyulan “Eğitimde FATİH (*Fırsatları Arttırma ve Teknolojiyi İyileştirme Hareketi*) Projesi”, son yıllarda eğitimde teknoloji reformu bağlamında adından sıkça bahsedilir bir konu haline gelmiştir. MEB tarafından duyurulan FATİH Projesi temelde, okulların teknolojik altyapılarının iyileştirilmesi kapsamında her dersliğe geniş bant internet erişimi, gerekli donanımların sağlanması amacını taşımaktadır. Bunun yanında eğitsel elektronik içeriğin (e-içerik) oluşturulması ve bu içeriğin öğretim süreçleri ile bütünleştirilmesi de yine projenin amaçları arasındadır. (Perkmen ve Tezci, 2011:6). Bu amaçları gerçekleştirme doğrultusunda tüm ülke çapındaki ilk ve ortaöğretim okullarına akıllı tahta ve yardımcı teknolojik cihazların sağlanacak, öğretmenlere ve öğrencilere tablet bilgisayarlar verilecek, tablet bilgisayar içine ders kitapları yerleştirilecek ve tüm bunlara ilave olarak eğitim materyallerinin birçoğuna internet üzerinden ulaşım imkânı verilecektir. (Öncü,2013:394; MEB, 2013). Proje halen tedarik aşamasında olduğu için bu uygulamaların bir kısmı gerçekleştirilmiş, bir kısmı da gerçekleştirilmeyi beklemektedir.

Yukarıdaki bilgiler ışığında bu çalışmanın amacı genel lise öğrencilerinin FATİH projesinin kullanım düzeyine ilişkin görüşlerini saptamaktır. Bu amaç doğrultusunda aşağıdaki sorulara yanıt aranmıştır:

1. Genel lise öğrencilerinin FATİH projesinin kullanım düzeyine ilişkin görüşleri nelerdir?
2. Genel lise öğrencilerinin FATİH projesinin kullanım düzeyine ilişkin görüşleri cinsiyet, alan ve öğrenim düzeyine göre farklılık göstermekte midir?

YÖNTEM

Evren ve Örneklem

Araştırmanın çalışma evrenini, 2012 - 2013 Eğitim Öğretim yılında Antalya ili Muratpaşa ilçe sınırları içinde bulunan ve Eğitimde FATİH projesi uygulanan 16 lisede öğrenim gören 14.185 öğrenci oluşturmaktadır. Alfa düzeyinin .05 olduğu dikkate alınarak yapılan örneklem hesaplamasında 16 lisenin tamamında (100%), 375 (3%) öğrenciden oluşan ve tesadüfi yöntemle oluşturulan bir örneklem alınmıştır.

Veri Toplama Aracı

Genel lise öğrencilerinin Eğitimde FATİH Projesi'nin kullanım düzeylerine ilişkin görüşleri belirlenirken, alanyazın taraması yapılmış ve alanyazında yer alan ölçekler incelenmiştir. MEB Eğitim Teknolojileri Genel Müdürlüğü FATİH Proje ekibi tarafından hazırlanan "FATİH Projesi Anketi" başlıklı anketin maddeleri öğrenciler için uyarlanmış ve bu maddelere alanyazın taraması sonucu elde edilen ilgili maddeler de eklenmiş, böylece toplamda 40 maddeden oluşan "Eğitimde FATİH Projesi'nin Kullanımında İlişkin Görüşler Anketi" başlıklı yeni bir anket elde edilmiştir. Yeniden tasarlanan anket maddeleri ile ilgili olarak uzman görüşleri de alındıktan sonra 5'li Likert tipinde olan anket öğrencilere uygulanmıştır. Nicel verilerin çözümlenmesinde likert ölçeğinde bulunan derecelerin çözümlenmesi 1,00 - 1,80: Çok düşük, 1,81 - 2,60: Düşük, 2,61 - 3,40: Orta, 3,41 - 4,20: Yüksek, 4,21 - 5,00: Çok yüksek, aralıklarına göre yapılmıştır.

Verilerin Analizi

Bilgisayara doğrudan girilen veriler üzerinden gerekli istatistiksel çözümler için SPSS 18.0 ve LISREL 8.54 paket programları kullanılmıştır. SPSS programından yararlanarak Eğitimde FATİH Projesi'nin kullanım düzeyine ilişkin görüşleri belirlemek için; frekans (f), yüzde (%), aritmetik ortalama (\bar{X}), standart sapma (SS), t-Testi, LSD ve tek yönlü varyans analizi (OneWay ANOVA) testleri kullanılmıştır. Araştırmada tüm istatistiksel analizlerin değerlendirilmesinde önemlilik düzeyi 0.05 olarak kabul edilmiştir. Uygulanan açıklayıcı faktör analizine göre Kaiser-Meyer-Olkin (KMO) test değeri, .822 olarak, Barlett's sphericity test sonucu ise 5375 ($p < .000$) olarak görülmüş, KMO'nun .60'dan yüksek, Barlett's sphericity testinin anlamlı çıkması da verilerin faktör analizi için uygun olduğunu göstermiştir. Uygulanan açıklayıcı faktör analizi sonucu ölçek maddelerinin 5 faktör altında toplandığı görülmüştür. Tüm boyutların toplam güvenilirlik düzeyi .8500'dır. Buna göre "E-İçerik Kullanımı", "Eğitim Gereksinimi", "Öğretim Süreçleri", "Öz-Yeterlik ve Proje Getirileri", "Kurum Yeterliliği" olarak belirlenen faktörlerin güvenilirlik düzeyleri sırasıyla .7990, .8770, .8680, .8010, .7440 olarak tespit edilmiştir. Öğrencilerin, Eğitimde FATİH Projesi'nin kullanım düzeyine ilişkin görüşlerinin belirlendiği anketin faktörleşme yapısının doğrulanması amacıyla doğrulayıcı faktör analizi uygulanmış ve elde edilen sonuçta göre uyum indeksleri [$\chi^2=341.78$, $sd=140$, $P<0,001$], (χ^2/sd)= 2.441, RMSEA=0,075, GFI=0,88 ve AGFI=0,83 olarak bulunmuştur. Uyum indeksleri incelendiğinde, χ^2/sd değerinin kabul edilebilir bir değere sahip olduğu ve RMSEA, GFI ve AGFI değerlerinin ise kabul edilebilir uyuma çok yakın değerlere sahip oldukları gözlenmiştir. Sonuç olarak ölçeğin beş faktörlü yapısı, doğrulayıcı faktör analizi ile de desteklenmiştir.

BULGULAR VE YORUMLAR

Bu bölüm problem cümlesi ve alt problemlere ait verilen çözümlenmesi ile elde edilen bulguları ve yorumları içermektedir.

Öğrencilerin Demografik Özellikleri

Araştırmaya genel lisede öğrenim gören 370 öğrenci katıldığı görülmektedir. Öğrencilerin 193'ü (%52,2) bayan, 177'si (%49,1) erkektir. Araştırmaya katılan öğrencilerden 156'sı (%42,2) fen bilimleri alanında eğitim görürken, 110'u (%29,7) Türkçe – matematik alanında ve 13'ü (%4,3) sosyal bilimler alanında eğitim görmektedirler. Yukarıdaki dağılıma göre araştırma öğrencilerinin 89'u (%24,1) 9. Sınıf seviyesinde, 120'si (%32,4) 10. Sınıf seviyesinde, 90'ı (%24,3) 11. Sınıf seviyesinde, 71'i (%19,2) 12. Sınıf seviyesinde eğitim görmektedirler.

Genel Lise Öğrencilerinin Genel Olarak Eğitimde FATİH Projesinin Kullanım Düzeyine İlişkin Görüşleri

Genel lise öğrencilerinin Eğitimde FATİH Projesi kullanım düzeyleri e-İçerik kullanımı ($\bar{X}=3,17$), eğitim gereksinimi ($\bar{X}=2,84$) ve kurum yeterliği boyutlarında ($\bar{X}=2,74$), "orta"; öğretim süreçleri ($\bar{X}=3,57$), öz-yeterlik ve proje getirileri ($\bar{X}=3,76$), boyutlarında "yüksek" değere sahiptir. Ortalamalara bakıldığında genel lise öğrencilerinin projenin kullanımında kendilerini yeterli görüp projenin getirilerine karşı yüksek düzeyde olumlu görüşe sahipken, projenin uygulama aşamasında kurumlarını yeterli görmemektedirler.

Tablo 1. Genel Lise Öğrencilerinin Genel Olarak Eğitimde FATİH Projesinin Kullanım Düzeyine İlişkin Görüşleri

Boyut	\bar{X}	SS
E-İçerik Kullanımı	3,1650	,82455
Eğitim Gereksinimi	2,8422	1,22812
Öğretim Süreçleri	3,5724	,84235
Öz-Yeterlik ve Proje Getirileri	3,7591	,85966
Kurum Yeterliliği	2,7419	1,01576

Genel Lise Öğrencilerinin Cinsiyet Değişkenine Göre Eğitimde FATİH Projesinin Kullanım Düzeyine İlişkin Görüşleri

Tablo 2 incelendiğinde öğrencilerin e-İçerik kullanımı [$t_{(368)} = 0,59$; $p>,05$], eğitim gereksinimi [$t_{(368)} = -0,30$; $p>,05$], öğretim süreçleri [$t_{(368)} = -0,42$; $p>,05$], öz-yeterlik ve proje getirileri [$t_{(368)} = 0,13$; $p>,05$] ve kurum yeterliği [$t_{(368)} = -0,06$; $p>,05$] boyutlarında cinsiyet değişkenine göre anlamlı bir farklılık bulunmamaktadır.

Tablo 2. Öğrencilerin Cinsiyet Değişkenine Göre Eğitimde FATİH Projesinin Kullanım Düzeyine İlişkin t-Testi Sonuçları

Boyut	Cinsiyet	N	\bar{X}	S	Sd	t	p
E-İçerik Kullanımı	Erkek	177	3,19	,84	368	,59	,553
	Kız	193	3,14	,80			
Eğitim Gereksinimi	Erkek	177	2,82	1,26	368	-,30	,760
	Kız	193	2,86	1,19			
Öğretim Süreçleri	Erkek	177	3,55	,84	368	-,42	,671
	Kız	193	3,59	,83			
Öz-Yeterlik ve Proje Getirileri	Erkek	177	3,76	,85	368	,13	,890
	Kız	193	3,75	,86			
Kurum Yeterliği	Erkek	177	2,73	1,01	368	-,06	,949
	Kız	193	2,74	1,02			

*p<.05, **p<.01, ***p<.001

Erkek öğrenciler ($\bar{X} = 3,19$) ve kız öğrenciler ($\bar{X} = 3,14$) derslerde e-İçerik kullanımının yüksek düzeyde olmadığını belirtmiş, benzer şekilde projenin uygulanması için eğitime olan gereksinimlerinin de orta düzeyde olduğunu bildirmişlerdir. Bu durum, öğrencilerin teknoloji ile tanışma yaşlarının erken oluşu dolayısıyla teknolojik cihazları kullanma yeteneklerinin yüksek olması ile açıklanabilir. Öğretim süreçleri boyutunda, erkek öğrenciler ($\bar{X} = 3,55$) ve kız öğrenciler ($\bar{X} = 3,59$), öğretim programları ile FATİH Projesi'nin sağlam temellere dayanan bir bütünleştirme içinde olduğu yönünde yüksek düzeyde olumlu görüş birliğindedirler. Erkek öğrenciler ($\bar{X} = 3,76$) ve kız öğrenciler ($\bar{X} = 3,75$) öz-yeterliklerinin ve FATİH Projesi'nin getirilerinin yüksek olduğu görüşünü bildirmişlerdir. Kurum yeterliği boyutunda erkek öğrenciler ($\bar{X} = 2,73$) ve kız öğrenciler ($\bar{X} = 2,74$) orta düzeyde bir görüş ortaya koymuşlardır. Bu sonuçtan hareketle erkek ve kız öğrencilerin, okullarının donanımsal yapıları hakkında olumlu görüşe sahip olmadıkları yargısı çıkarılabilir.

Genel Lise Öğrencilerinin Alan Değişkenine Göre Eğitimde FATİH Projesinin Kullanım Düzeyine İlişkin Görüşleri

Tablo 3 incelendiğinde, e-İçerik kullanımı [F(2-276)= 0,819 , p<.05], eğitim gereksinimi boyutunda [F(2-276)= 0,476, p<.05], öğretim süreçleri boyutunda [F(2-276)= 0,912, p<.05], öz-yeterlik ve proje getirileri boyutunda [F(2-276)= 0,962, p<.05] ve kurum yeterliği boyutunda [F(2-276)= 2,792 , p<.05] alan değişkenine göre öğrenciler arasında anlamlı fark bulunmamaktadır.

Tablo 3. Genel Lise Öğrencilerinin Alan Değişkenine Göre Eğitimde FATİH Projesinin Kullanım Düzeyine İlişkin Tek Yönlü Varyans Analizi ve LSD Testi Sonuçları

Boyut	Varyansın Kaynağı	Kareler Toplamı	Serbestlik Derecesi	Kareler Ortalaması	F	p	Anlamlı Fark
E-İçerik Kullanımı	Gruplar arası	1,044	2	,522	,819	,442	Yok
	Grup içi	175,914	276	,637			
	Toplam	183,738	278				
1. Fen Bilimleri (3,09, S:0,82) 2. Türkçe - Matematik (3,08, S:0,76) 3. Sosyal Bilimler (2,80, S:0,79)							
Eğitim Gereksinimi	Gruplar arası	1,365	2	,683	,476	,622	Yok
	Grup içi	395,518	276	1,433			
	Toplam	396,884	278				
1. Fen Bilimleri (2,82, S:1,16) 2. Türkçe - Matematik (2,94, S:1,24) 3. Sosyal Bilimler (2,67, S:1,25)							
Öğretim Süreçleri	Gruplar arası	1,374	2	,687	,912	,403	Yok
	Grup içi	207,835	276	,753			
	Toplam	209,209	278				
1. Fen Bilimleri (3,45, S:0,90) 2. Türkçe - Matematik (3,55, S:0,81) 3. Sosyal Bilimler (3,26, S:0,99)							
Öz-Yeterlik ve Proje Getirileri	Gruplar arası	,059	2	,029	,039	,962	Yok
	Grup içi	209,893	276	,760			
	Toplam	209,952	278				
1. Fen Bilimleri (3,64, S:0,95) 2. Türkçe - Matematik (3,62, S:0,72) 3. Sosyal Bilimler (3,58, S:1,05)							
Kurum Yeterliği	Gruplar arası	5,289	2	2,644	2,792	,063	Yok
	Grup içi	261,375	276	,947			
	Toplam	266,664	278				
1. Fen Bilimleri (2,66, S:0,96) 2. Türkçe - Matematik (2,73, S:1,02) 3. Sosyal Bilimler (2,58, S:0,68)							

*p<.05, **p<.01, ***p<.001

Her ne kadar istatistiksel olarak öğrenciler arasında alan değişkenine göre anlamlı bir farklılık olmasa da aritmetik ortalamalar incelendiğinde fen bilimleri ve Türkçe - matematik alanlarında öğrenim gören öğrencilerin öğretim süreçleri ile projenin bütünleştirilmesi konusunda yüksek düzeyde olumlu görüşe sahip olduğu, sosyal bilimler alanındaki öğrencilerin ise orta düzeyde olumlu görüşe sahip olduğu görülmüştür.

Genel Lise Öğrencilerinin Öğrenim Seviyesi Değişkenine Göre Eğitimde FATİH Projesinin Kullanım Düzeyine İlişkin Görüşleri

Tablo 4'e göre, e-İçerik kullanımı boyutunda [F(3-366)= 4,367 , p<.05] öğrenim seviyesi değişkenine göre öğrenciler arasında anlamlı fark bulunmaktadır. Aritmetik ortalamalar incelendiğinde, 9. sınıf öğrencileri

öğretmenlerinin ders işlenişinde e-çerik kullanım düzeylerini "yüksek" olarak belirtirken diğer öğrenim seviyelerindeki öğrenciler "orta" düzeyde kullanım olduğuna dair görüş bildirmişlerdir.

Tablo 4. Genel Lise Öğrencilerinin Öğrenim Seviyesi Değişkenine Göre Eğitimde FATİH Projesinin Kullanım Düzeyine İlişkin Tek Yönlü Varyans Analizi ve LSD Testi Sonuçları

Boyut	Varyansın Kaynağı	Kareler Toplamı	Serbestlik Derecesi	Kareler Ortalaması	F	p	Anlamlı Fark
E-İçerik Kullanımı	Gruplar arası	9,186	3	3,062	4,637**	,003	1-2, 1-3, 1-4
	Grup içi	241,688	366	,660			
	Toplam	250,874	369				
		1.9.Sınıf (3,42, S:0,82) 2. 10. Sınıf (3,17, S:0,77) 3. 11. Sınıf (3,01, S:0,83) 4. 12. Sınıf(3,04, S:0,85)					
Eğitim Gereksinimi	Gruplar arası	4,620	3	1,540	1,021	,383	Yok
	Grup içi	551,933	366	1,508			
	Toplam	556,553	369				
		1.9.Sınıf (2,76, S:1,30) 2. 10. Sınıf (2,88, S:1,22) 3. 11. Sınıf (3,00, S:1,16) 4. 12. Sınıf(2,69, S:1,25)					
Öğretim Süreçleri	Gruplar arası	10,162	3	3,387	4,926**	,002	1-2, 1-3, 1-4
	Grup içi	251,663	366	,688			
	Toplam	261,825	369				
		1.9.Sınıf (3,86, S:0,69) 2. 10. Sınıf (3,52, S:0,80) 3. 11. Sınıf (3,41, S:0,95) 4. 12. Sınıf(3,52, S:0,87)					
Öz-Yeterlik ve Proje Getirileri	Gruplar arası	26,630	3	8,877	13,203	,000	1-2, 1-3, 1-4,
	Grup içi	246,066	366	,672	***		2-3,
	Toplam	272,696	369				
		1.9.Sınıf (4,13, S:0,71) 2. 10. Sınıf (3,86, S:0,78) 3. 11. Sınıf (3,55, S:0,79) 4. 12. Sınıf(3,40, S:1,02)					
Kurum Yeterliği	Gruplar arası	10,246	3	3,415	3,374**	,019	1-4
	Grup içi	370,477	366	1,012			
	Toplam	380,723	369				
		1.9.Sınıf (2,97, S:1,07) 2. 10. Sınıf (2,76, S:0,96) 3. 11. Sınıf (2,70, S:1,00) 4. 12. Sınıf(2,47, S:1,00)					

*p<.05, **p<.01, ***p<.001

Öğretim süreçleri boyutunda [$F(3-366)= 4,926$, $p<.05$] öğrenim seviyesi değişkenine göre öğrenciler arasında anlamlı fark bulunmaktadır. Ortalamalara bakıldığında, 9. sınıf öğrencilerinin FATİH Projesi'nin kullanımına yönelik uygulamaların öğretim programlarına entegre edilmesine ilişkin olarak, 10., 11., 12. sınıf öğrencilerine göre daha yüksek düzeyde olumlu görüş içindedirler. Buna göre 9. sınıf öğrencileri mevcut öğretim programlarına proje bütünleştirmesinden, diğer kademelerdeki arkadaşlarına göre daha yüksek seviyede memnundurlar.

Öğrencilerin öz-yeterlik ve proje getirileri boyutunda [$F(3-366)= 13,203$, $p<.05$] öğrenim seviyesi değişkenine göre öğrenciler arasında anlamlı fark bulunmaktadır. Ortalamalar göstermektedir ki, 9. sınıf öğrencileri, diğer kademedeki arkadaşlarına kıyasla kendilerini projenin uygulanabilmesi için daha yüksek düzeyde yeterli görmekte olup FATİH Projesi'nin sunduğu materyallerin eğitime olan katkısı üzerinde daha yüksek seviyede olumlu görüşe sahiptirler. Bununla beraber, 10. sınıf öğrencileri de 11. sınıf öğrencilerine karşı öz-yeterlik ve FATİH Projesi'nin getirileri konusunda yüksek seviyede olumlu görüşe sahiptirler. Kurum yeterliği boyutunda [$F(3-366)= 3,374$, $p<.05$] öğrenim seviyesi değişkenine göre öğrenciler arasında anlamlı fark bulunmaktadır. Aritmetik ortalamalar incelendiğinde, her ne kadar 9. sınıf ve 12. sınıf öğrencileri FATİH Projesi'nin kullanım düzeyine ilişkin kurumlarını "orta" düzeyde yeterli görseler de, 12. sınıf öğrencileri, 9. sınıf öğrencilerine göre kurumlarının yeterliliği hakkında daha olumlu görüşe sahiptirler.

SONUÇ

Öğrenciler arasında Eğitimde FATİH Projesinin kullanım düzeyine ilişkin cinsiyet değişkenine bağlı görüşler incelendiğinde hiçbir boyutta anlamlı farklılığa rastlanamamıştır. Ancak, Öz-yeterlik ve proje getirileri boyutunda erkek öğrencilerin kız öğrencilere göre daha yüksek düzeyde olumlu görüş belirtmesi Işıksal ve Aşkar (2003) tarafından yapılan çalışma sonuçları ile paralellik göstermektedir. Kurum yeterliği boyutunda hem erkek hem kız öğrencilerin düşük seviyede olumlu görüş bildirerek kurumlarını FATİH Projesi kapsamında sunulan donanımsal altyapı açısından yeterli bulmamaları, öğrencilerin yaşları itibarıyla teknoloji ile tanışmışlıklarının çok erken olması, teknoloji ile donatılmış bir yaşantılarının olması ve okul içinde de bu düzeyde yüksek teknolojik materyallerinin kendilerine sunulması yönünde beklentilerinin olması ile açıklanabilir.

Öğrencilerin alan değişkenine bağlı olarak incelenen Eğitimde FATİH Projesinin kullanım düzeyine ilişkin görüşlerinde gruplar arasında tüm boyutlarda anlamlı farklılığa rastlanamamıştır. Kurum yeterliği ve öğretim süreçleri boyutlarında istatistiksel anlamda bir farklılığa rastlanmamasına rağmen aritmetik ortalamalar bize, sosyal bilimler alanındaki öğrencilerin bu boyutlarda diğer alanlardaki öğrencilere göre daha düşük düzeyde olumlu görüşe sahip olduklarını göstermektedir. Bu sonuç, sosyal bilimler alanlarındaki öğrencilerinin yaşadığı öğretim süreçlerinin her bir unsurunda projenin içerdiği gerekli güncellemenin yeterli şekilde yapılamaması olması ve derslerde proje bileşenlerinin yeterli biçimde kullanılmadığı konusunda bize fikir vermektedir.

Öğrenciler arasında öğrenim seviyesine bağlı olarak Eğitimde FATİH Projesinin kullanım düzeyine ilişkin görüşler incelendiğinde eğitim gereksinimi boyutu hariç tüm boyutlarda anlamlı farklılıklar olduğu sonucuna varılmıştır. Tüm sınıflar öğrenim seviyesinden bağımsız olarak "orta" seviyede Eğitimde FATİH Projesinin kullanım düzeyine ilişkin eğitime ihtiyaç duyduklarını belirtmişlerdir. E-çerik kullanımı üzerine 9. sınıf öğrencileri "yüksek" düzeyde olumlu görüş bildirirken, diğer gruplar "orta" düzeyde; kurum yeterliği boyutunda ise 12. sınıf öğrencileri kurumlarını Eğitimde FATİH Projesinin uygulanabilmesi için yetersiz bulurken, diğer grupların "orta" düzeyde yeterli buldukları söylenebilir. Öğretim süreçleri boyutuna ait ortalamalar incelendiğinde ise anlamlı farklılığın 9. sınıf öğrencileri ile diğer tüm seviyedeki öğrenciler arasında olduğu görülmektedir. Her ne kadar aralarında anlamlı farklılık bulunsa da tüm seviyedeki öğrenciler öğretim süreçlerinin Eğitimde FATİH Projesinin uygulanmasına yardımcı olacak şekilde güncellenmesini yüksek düzeyde gerekli görmektedirler. Ortalamalara göre, 9. sınıf öğrencilerinin FATİH Projesi öğelerinden olan e-çerik kullanımı boyutundan en yüksek düzeyde olumlu görüş bildirmelerinin nedeni, kendi öğrenim düzeyleri için hazırlanan mevcut e-çeriklerin çok sayıda olması ile açıklanabilir. Bu e-çeriklerin miktarının çok olması ancak aynı yoğunlukta ders öğretim süreçleri ile bütünleştirilmemesi de 9. sınıf öğrencilerinin bu durumdan duydukları rahatsızlığın sebebi olarak gösterilebilir.

KAYNAKÇA

- Aggarwal, A. (2000). *Web-Based Learning and Teaching Technologies: Opportunities and Challenges*. Hershey-USA: IdeaGroup Publishing.
- Ajjan, H., & Hartshorne, R. (2008). Investigating faculty decisions to adopt web 2.0 technologies: Theory and empirical tests. *The Internet and Higher Education*, 11 (2), 71-80.
- Akpınar, Y., Bal, V., Şimşek, H. (2005). E-Portfolyolarla Öğrenme Ortamı Geliştirme ve Destekleme Platformu. *The Turkish Online Journal of Educational Technology*, 4(4), 125-129.
- Alkan, C. (1997). *Eğitim Teknolojisi*. Ankara: Anı Yayıncılık
- Alkan, C., Deryakulu, D. ve Şimşek, N. (1995). *Eğitim Teknolojisine Giriş: Disiplin, Süreç, Ürün*. Ankara: Önder Matbaacılık.
- Bayturan, S. (2008). *Ortaöğretim Matematik Eğitiminde Bilgisayar Destekli Öğretimin Öğrencilerin Başarıları, Tutumları ve Bilgisayar Öz - Yeterlik Algıları Üzerindeki Etkisi*. Doktora Tezi. Dokuz Eylül Üniversitesi, İzmir.
- Cuban, L., Kirkpatrick, H., & Peck, C. (2001). High access and low use of technologies in high school classrooms: Explaining an apparent paradox. *American Educational Research Journal*, 38(4), 813-834.
- Hew, K., F. ve Brush, T. (2007). Integrating technology into K-12 teaching and Learning: current knowledge gaps and recommendations for future research. *Education Technology Research & Development*, 55, 223-252
- Işık, O. (1981). *Teknoloji Üretimi, Teknoloji Transferi*. 2. Türkiye Sanayi Komisyonu Tebliği, İzmir: DPT Yayın No: 1783
- Işıksal, M. ve Aşkar, P. (2003). İlköğretim Öğrencileri İçin Matematik ve Bilgisayar Öz-Yeterlik Algısı Ölçekleri, *Hacettepe Üniversitesi Eğitim Fakültesi Dergisi*, 25, 109-118
- İnel, D., Evrekli, E., Balım, A. G. (2011). Öğretmen Adaylarının Fen ve Teknoloji Dersinde Eğitim Teknolojilerinin Kullanılmasına İlişkin Görüşleri. *Afyon Kocatepe Üniversitesi Kuramsal Eğitim Bilim Dergisi*, 4(2), 128 - 150.
- MEB. (2013). *FATİH Projesi*. Web: <http://fatihprojesi.meb.gov.tr> adresinden 22.02.2013 tarihinde indirilmiştir.
- Perkmen S. ve Tezci, E. (2011). *Eğitimde Teknoloji Entegrasyonu*. Ankara: Pegem A Yayıncılık.
- Yılmaz, K., Horzum, B., M. (2005). Küreselleşme, Bilgi Teknolojileri ve Üniversite. *İnönü Üniversitesi Eğitim Fakültesi Dergisi*, 6(10), 103 - 121.
- Uşun, S. (2004). *Bilgisayar Destekli Öğretimin Temelleri*. Ankara: Nobel Basın Yayın Dağıtım.
- Öncü, S. (2013). Eğitimde Sistemik Değişim, K. Çağıltay ve Y. Göktaş. (Editörler). *Öğretim Teknolojilerinin Temelleri: Teoriler, Araştırmalar Eğilimler*. 373-396 (Birinci Baskı). Ankara: Pegem A Yayıncılık.

THE DEVELOPMENT OF AN INQUIRY BASED LEARNING UNIT FOR INTEGRAL CALCULUS: THE CASE OF VOLUMES OF SOLIDS OF REVOLUTION

Çiğdem ÖZDEMİR

Erdat CATALOĞLU, Ph.D.
Bilkent University

ABSTRACT: The latest official national curriculum published by the Turkish Ministry of Education, now formally requires high-school mathematics teachers to actively incorporate computer software in their teaching. The primary purpose of this study is to demonstrate the development of an inquiry based learning unit especially geared for high school mathematics students and teachers for the general concept of integral calculus. The main theme chosen as a case for this proposed inquiry unit, is on volumes of solids of revolution of real life daily objects. As a result, the primary purpose will provide a report about a practical example of using pedagogically driven mathematics software, 3D digital modeling coupled with hands-on real life examples all embedded in a constructivist learning environment. A secondary goal of this study is to expose pre-service high-school mathematics teachers to this inquiry unit as a teacher and student. Finally, the shared experiences about the interconnected nature of knowledge construction through a double “lens”, that is as a teacher and students through collaboratively building, testing and reflecting on their learning process will be reported.

Keywords: Mathematic Education, Inquiry, Modeling, Teacher Education

INTRODUCTION

The perspective of Turkish Ministry of National Education on technology in the new curriculum

The current official Turkish high school mathematics curriculum dictates the use of technology in mathematics classrooms (MoNE, 2013). The Turkish MoNE mathematics curriculum points out the fact that, both quality and quantity of teaching software related to mathematics education has increased as a result of the constant development of computer technology. Hence, the ministry expects mathematics teachers to make use of technology in mathematics classrooms. They emphasize that the utilization of technology could provide new learning and teaching opportunities for both teachers and students alike. Accordingly, using information and communication technology effectively, students could work on mathematical problems related to real life and they could spend more time on reasoning and creative thinking rather than time consuming computations.

The new mathematics curriculum summarizes the main information and communication technologies to be used in mathematics classrooms as; dynamic geometry software, graphing software, spreadsheet software, graphing calculators, interactive smart boards and tablets, data acquisition devices, computer algebra systems, dynamic statistics software and Internet. Correspondingly, Turkish MoNE expects students to use these technologies effectively in the new curriculum. Thus, students could explore the mathematical concepts through experiencing different types of thinking skills.

Inquiry based learning

Inquiry based learning is a concept which enables students to involve in conceptual understanding and builds students' ideas through inquiry (Chapman, 2011) {Formatting Citation}. The concept of inquiry based learning has grown since Dewey (1938) supported that students can learn better when they investigate the problems according to their own experiences as cited in Barrow (2006). Several studies emphasizes that inquiry based learning plays a remarkable role in mathematics education (Chapman, 2011; Häikiöniemi, 2013; National Council of teachers of Mathematics, 2000). However, there are some challenges in implementing inquiry based teaching in mathematics classrooms (Dorier & Garcia, 2013). Teacher beliefs and attitudes towards inquiry based mathematics teaching might be the main reasons of those challenges (Engeln, Euler, & Maass, 2013). Therefore, teachers should be supported to engage students in conceptual understanding through inquiry based teaching (Häikiöniemi, 2013).

Technology enriched inquiry based learning

Many researchers support that integrating technology into mathematics classrooms enriches inquiry based learning (Hähkiöniemi, 2013; Hakverdi-Can & Sönmez, 2012; Wentworth & Monroe, 2011). According to Hähkiöniemi (2013), particularly dynamic mathematics software promotes students' investigation and exploration opportunities. Similarly, Healy and Hoyles (2001) suggest that, with the help of dynamic mathematics software, "students move from argumentation to logical deduction" (p. 235). Moreover, students could relate one geometrical representation of a formula to another and they could build hypotheses through trial and error that they apply with dynamic mathematics software.

In this study, GeoGebra was used as the dynamic mathematics software. With the help of GeoGebra, students are able to see the relationship between the theoretical formulas and their geometric meanings. Thus, students could explore the use of those formulas in their daily lives.

Teaching integral calculus

Integral calculus is perceived as challenging by many of high school students in developing conceptual understanding because of many formal definitions. According to Orton (1983), students are struggling while solving problems that they need to notice integration as a limit process of sums. Moreover, Attorps, Björk and Radic (2013) suggest that some students perceive solving integral problems as technical ability and although they do all the calculations successfully, they may not achieve conceptual understanding. As a result, the reason why students have difficulties in integral calculus is that they fail to construct a concrete meaning of the formal definitions in their mind.

The main purpose of this study is to develop a material for teachers to provide students' conceptual understanding in integral calculus through a technology integrated inquiry based lesson. Since inquiry based learning requires to work on a concept like a scientist, first of all students should understand how scientists found integral calculus. If students could understand for which need they do the integration calculations, they could build their own hypothesis, and thus, they could achieve conceptual understanding instead of solving integral calculus problems technically.

The volume of solids of revolution

In this study, particularly volume of solids of revolution was chosen as a case for this proposed inquiry based unit plan. The volume of solids of revolution is a concept of integral calculus which is thought to high school students. To get a solid of revolution, first of all, a function $y=f(x)$ is needed on an interval $[a, b]$. When we rotate this function about the x-axis, we get a three dimensional region which is called as a solid of revolution. In order to find the volume of this solid, we use the Riemann Sums approach by which we find the area under a curve by dividing the interval into finite many small subintervals as rectangles with the width Δx and length $f(x_i)$ and summing the areas of these rectangles, passing to the limit where the length of the largest subinterval goes to zero. The representation of this sum is given by the formula;

$$f(x_i)\Delta x = \int_a^b f(x)dx$$
$$\sum_{i=1}^n \Delta A = \lim_{\Delta x \rightarrow 0} \square$$

In the case of solids of revolution we get circular disks with the length Δx and radius $f(x_i)$ instead of rectangles, and we calculate the sum of the volumes of these disks passing to the limit where the length of the largest subinterval goes zero. The volume of each circular disks are given by

$$\pi f(x_i)^2 \Delta x$$

and the sum of these circular disks passing to the limit where Δx goes zero is given by the formula;

$$V = \lim_{\Delta x \rightarrow 0} \sum_{i=1}^n \pi f(x_i)^2 \Delta x$$

Finally, we use the integral formula to compute the volume V of the solid of revolution;

$$V = \pi \int_a^b f(x)^2 dx$$

This study will provide students to relate the integration formula for volumes of solids of revolution to their daily lives through hands-on activities. These activities will be done in a laboratory setting. Students will first find the volume of a solid that is obtained by revolving a curve around various lines such as glasses and bottles by a volume measuring cup. Accordingly, students will insert the image of their object on GeoGebra in correspondence with the size of real object. Then, students will find the function of the object by plotting on the borders of the object and finding the line of best fit. Thus, students could apply the integration formula for volumes of solids of revolution with that line. As a result, students will see that the result approximately corresponds with the volume that they found first. The figures below depict three examples.

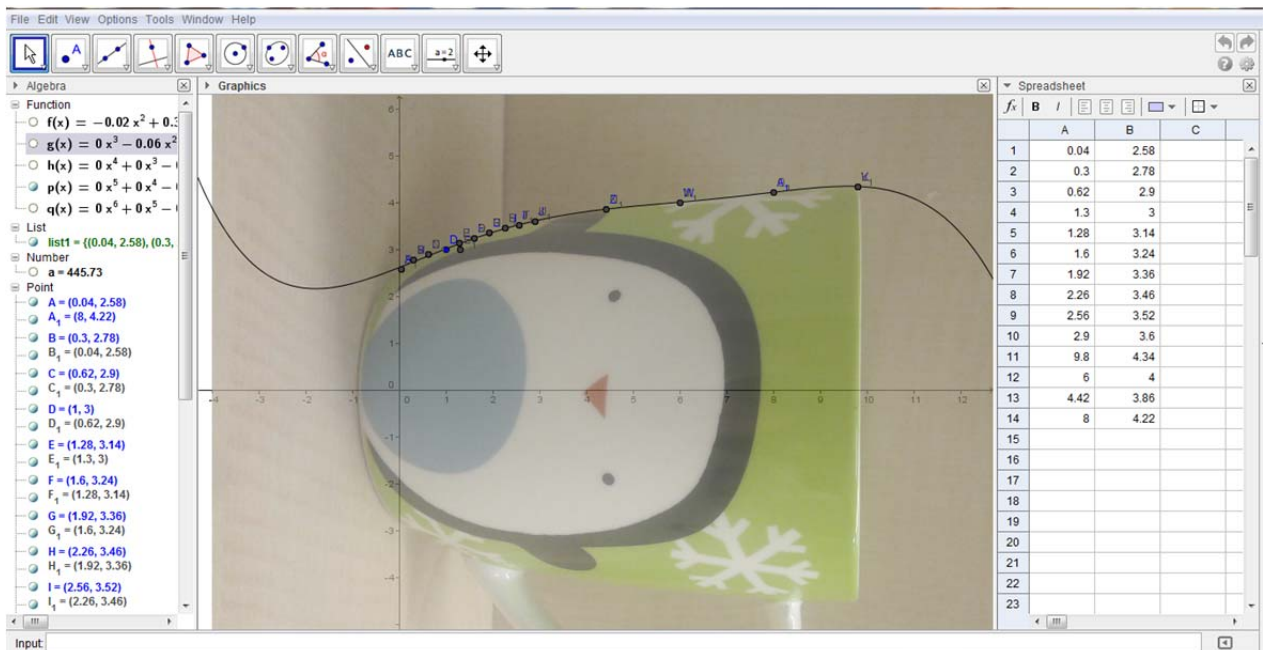

Figure 1. Volume Of A Mug

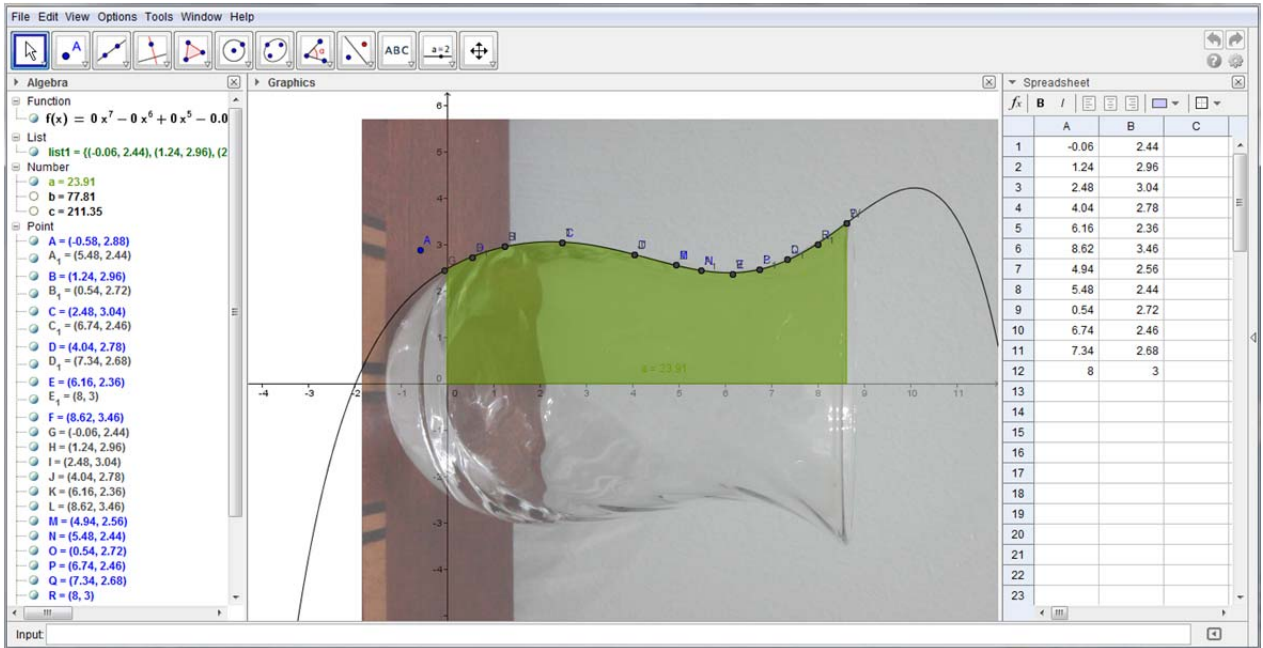

Figure 2. Volume Of A Traditional Turkish Tea Glass.

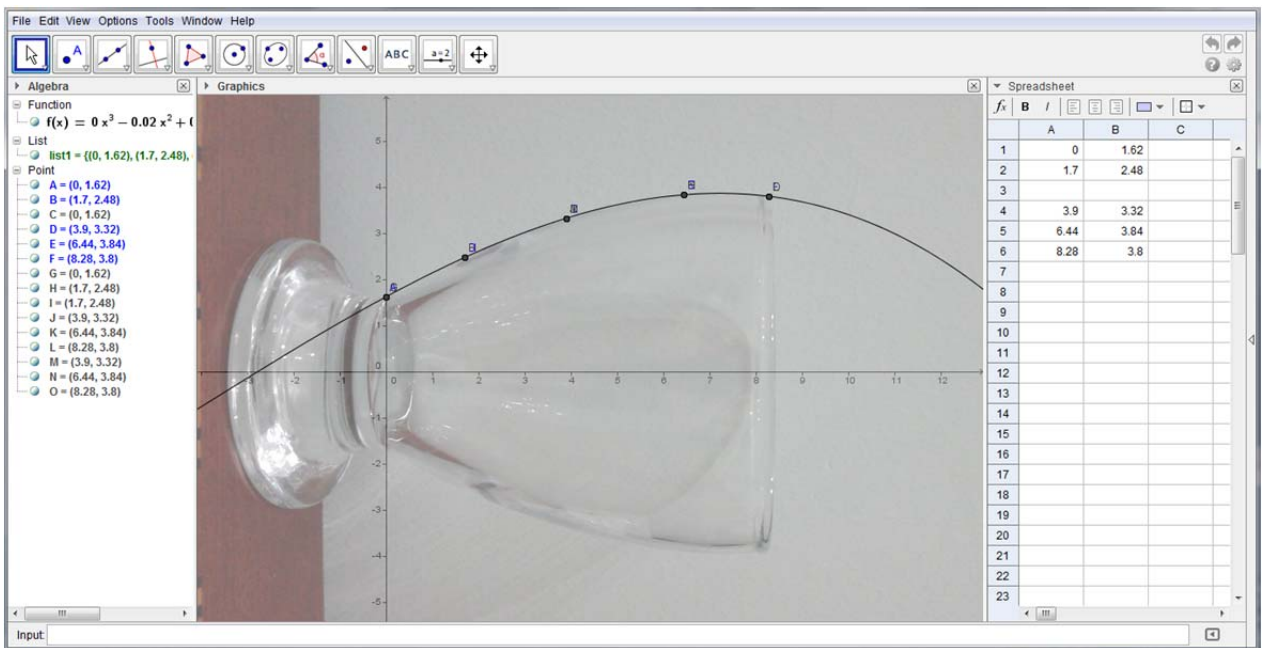

Figure 3. Volume Of A Glass

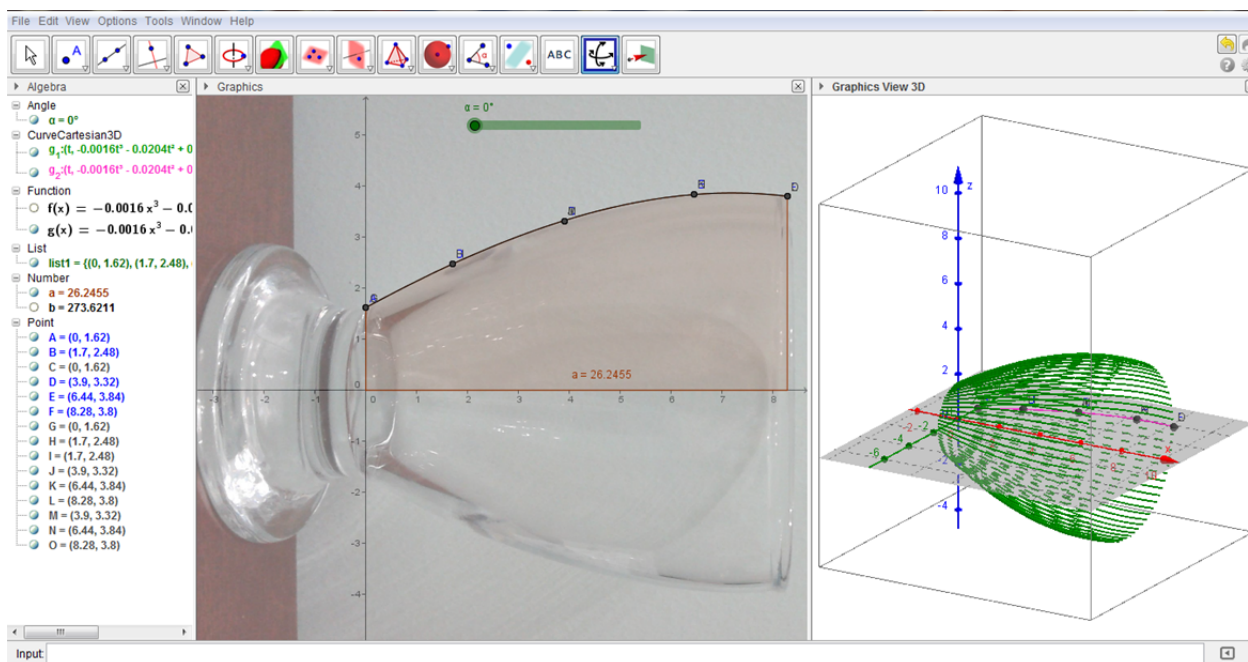

Figure4. 3D Representation Of Volume Of A Glass

I will now explain how I had done one of these sample experiments. For example, in *Figure 3* and *Figure 4* firstly I filled the glass with water and then transferred the water into a volume measuring cup. Thus, I measured the volume of the glass as 275 ml which is equal to 275 cm^3 . Then I took a photo of the glass and I inserted the image into GeoGebra as a background picture. I arranged the properties of the picture in correspondence with the length of filled part of the real glass which is approximately 8cm on the coordinate system. In order to find the curve of the border of the glass I plotted some points on the border of the glass and I entered x and y coordinates of those points on the spreadsheet view of GeoGebra. Thus, I found the line of best fit by creating a list of these points and entering them into the input box with the

$$\text{FitPoly}[\langle \text{List of Points} \rangle, \langle \text{Degree of Polynomial} \rangle]$$

command. I chose the degree of polynomial as three which gave the best curve of the border of the glass and I found the line of best fit function as

$$f(x) = -0.002x^3 - 0.02x^2 + 0.541x + 1.622$$

Accordingly, I calculated

$$\pi \int_0^{8.28} f(x)^2 dx$$

which is the formula for volume of solids of revolution by using input box command

$$\text{Integral}[\langle \text{Function} \rangle, \langle \text{Start x-Value} \rangle, \langle \text{End x-Value} \rangle].$$

Consequently, the calculation gave the volume of the glass as 273.621 cm^3 which is an approximate value of the real volume of the glass.

My experiences as a student and as a teacher

In this section, I mentioned my experiences in terms of my lack of mathematics knowledge during my formal education and my difficulties in using dynamic mathematics software which I was not familiar with. Firstly, I mentioned how I was taught mathematics in particular integral calculus during my formal education. Then I remarked the importance of using dynamic mathematics software in mathematics education through my experiences. Finally, I reflected my experiences in terms of difficulties that I had during the process of doing modeling activities by using GeoGebra.

The major portion of my formal education was formed in a traditional way. As far as mathematics education was concerned, I had difficulties in abstract mathematical concepts such as integral calculus, because I always

memorized the formal formulas and applied those formulas to challenging problems. Therefore, I always tried to improve my memorization skills; however I had forgotten the formal formulas in a short time. Thus, I had never learned the basic logic behind these concepts. For example, when I learned the integration formula as antidifferentiation, I did a lot of challenging exercises without knowing what I came up with. All those calculations were related to transforming one expression to another. I was successfully computing that;

$$\int \frac{4}{1-2x} dx = -2 \ln |1-2x| + c$$

by using integration properties, but I did not know why I was doing these computations. However, I actually did not need to know the reason, as only successful computation was enough to get good marks from the exams.

Moreover, although I knew that $\int_a^b f(x) dx$ formula refers to the area under $f(x)$ curve between $[a, b]$ interval and $\pi \int_a^b f(x)^2 dx$ formula refers to the volume of revolution of $f(x)$ curve, I did not know how these formulas give the area or a volume. On the other hand, I was good at solving 'Find the area under $f(x)$ ' or 'Find the volume of revolution of $f(x)$ ' types of problems, as I memorized which formula to be used for which situation, thus I applied the appropriate formula and did the appropriate calculations. Since I was studying exam orientated, I never wondered if these formulas really give an area or a volume.

As I experienced that dynamic mathematics software enable students to see the geometric representations of mathematical calculations, I was interested in using GeoGebra in teaching of integral calculus. By doing these GeoGebra experiments, I saw the instant visual geometrical outcomes of my calculations, thus I could analyze if they are meaningful or not. For example, firstly I found the volume of a glass by a measuring cup, but when I inserted the image of the glass and applied the integral formulas; I found a value which did not correspond with the real volume. Then, I realized that I did not place the image on the coordinate system in correspondence with the real glass. Moreover, as the notation of GeoGebra is similar to mathematical notation, it was easy to understand and use. Using GeoGebra also enabled me to consciously decide what operations to use as I saw the geometric representations of my operations. As a teacher, I thought that I could easily gain students curiosity through this kind of real life experiment and I could provide them with meaningful and conceptual understanding. For example, as a student I felt a great pleasure when I found the volume of the glass via Geogebra approximately same with the real volume of the glass.

On the other hand, I also had difficulties in doing the modeling activities both as a teacher and as a student. For example, I had never used dynamic mathematics software in my mathematics education; therefore it took time to get the basic logic behind GeoGebra. In order to do these kinds of experiments, firstly I had to learn the basic commands, notations and features of GeoGebra. However, there were plenty of sources that I could utilize through this process. For example I utilized from the GeoGebra Tube, GeoGebra forum, or YouTube videos created for teaching mathematics via GeoGebra. Nevertheless, sometimes it took a lot of time to find the appropriate feature that I need to use for my experiments. Although a lot of outcomes that I need to achieve are shown in applets or videos, I had difficulties in understanding which features of GeoGebra were used to achieve those outcomes. For instance, I had difficulties in finding the appropriate function that fits to the edges of my objects. Thus, I gave up many times. I needed to be patient in order to get the appropriate outcomes.

The views of pre-service high school mathematics teachers

The secondary goal of this study is to get the views of pre-service teachers' as both students and teachers through this inquiry based unit plan. Accordingly, a set of tutorials will be given to pre-service high school mathematics teachers and their learning process will be reported. Afterwards, their view of teaching integral calculus via a technology integrated inquiry based unit plan will be reported through several interviews.

REFERENCES

- Barrow, L. H. (2006). A Brief History of Inquiry: From Dewey to Standards. *Journal of Science Teacher Education*, 17(3), 265–278. doi:10.1007/s10972-006-9008-5
- Chapman, O. (2011). Elementary school teachers' growth in inquiry-based teaching of mathematics. *Zdm*, 43(6-7), 951–963. doi:10.1007/s11858-011-0360-3

- Engeln, K., Euler, M., & Maass, K. (2013). Inquiry-based learning in mathematics and science: a comparative baseline study of teachers' beliefs and practices across 12 European countries. *Zdm*, 45(6), 823–836. doi:10.1007/s11858-013-0507-5
- Dorier, J. L., & Garcia, F. J., (2013). Challenges and opportunities for the implementation of inquiry-based learning in day-to-day teaching, 837–849. doi:10.1007/s11858-013-0512-8
- Hähkiöniemi, M. (2013). Teacher's reflections on experimenting with technology-enriched inquiry-based mathematics teaching with a preplanned teaching unit. *The Journal of Mathematical Behavior*, 32(3), 295–308. doi:10.1016/j.jmathb.2013.03.007
- Hakverdi-can, M., & Sönmez, D. (2012). Learning how to design a technology supported inquiry-based learning environment, 23(4), 338–352.
- Healy, L., & Hoyles, C. (2001). Software tools for geometrical problem solving: potentials and pitfalls, 235–256.
- Milli Eğitim Bakanlığı (MEB) Talim Terbiye Kurulu Başkanlığı (TTKB), (2013). Ortaöğretim Matematik Dersi Öğretim Programı. Ankara
- Orton, A. (1983). Student's understanding of integration. *Educational Studies in Mathematics*, 14(1), 1-18.
- Wentworth, N., & Monroe, E. E. (2011). Inquiry-Based Lessons That Integrate Technology: Their Development and Evaluation in Elementary Mathematics Teacher Education. *Computers in the Schools*, 28(4), 263–277. doi:10.1080/07380569.2011.620938

WEB TASARIMI VE PROGRAMLAMA DERSİ İÇİN WEB TABANLI EĞİTİMİN ÖĞRENME ÜZERİNE ETKİSİ

THE INVESTIGATION OF THE EFFECT OF WEB-BASED TRAINING MODULE ON LEARNING FOR WEB DESIGN AND PROGRAMMING COURSE

Hüseyin Gültekin VURAL
Meram Teknik ve Endüstri Meslek Lisesi Bilişim Teknolojileri Alanı
hgural@gmail.com

Kubilay TAŞDELEN
Süleyman Demirel Üniversitesi Teknoloji Fakültesi Elektrik-Elektronik Mühendisliği
kubilaytasdelen@sdu.edu.tr

ÖZET: Bilişim Teknolojileri alanındaki gelişmeler sonucunda, insanoğlunun teknik, ekonomik ve toplumsal alanlardaki iletişiminde kullandığı ve bilimin dayanağı olan bilgiye erişmesi çok hızlı bir hale gelmiştir. Bilgiye erişim yollarının ve hızının artması, eğitim alanında da kendini göstermiş ve bir uzaktan eğitim modeli olan web tabanlı eğitim uygulamalarının geliştirilmesine başlanılmıştır.

Web tabanlı eğitim ile bireyler arası fırsat eşitliğinin sağlandığı bir ortamda bireylerin öğrenmelerini sağlamak ve istedikleri yer ve zamanda, kişisel gereksinimlerine en iyi şekilde karşılık verebilmek amaçlanmaktadır.

Bu çalışmada, web tasarımı ve programlama dersi için web tabanlı eğitim modülü tasarlanarak, öğrencilerin istedikleri zaman ve mekânda derslerin notlarına erişme ve uygulamalarını yapabilmelerine, derste aldıkları konular ile ilgili sonuçlarını hemen görebildikleri deneme yanıtları yapabilmelerine, eksiklerini tamamlamalarına olanak veren soruları sıklıkla çözebilmelerine, ders öğretmeni ile fikir alışverişinde bulunabilmelerine olanak sağlanmıştır. Çalışmanın sonunda öğrencilerden gelen geri bildirimler ve ders geçme notları değerlendirilerek, hazırlanan bu web tabanlı eğitim modülünün öğrenme üzerine etkisi incelenmiştir.

Anahtar sözcükler: web tabanlı eğitim, web tasarımı ve programlama

ABSTRACT: As a result of the developments in instructional technologies, accessibility of the information by human beings that is used in communication in the technical, economical and social fields, and that forms basis for science, has become faster. The increase in speed and ways to access information makes itself visible in the educational field, and web-based training application, which is a distance education model, has started to be developed.

It is aimed to provide learning of individuals in the environment in which equal opportunities between individuals are provided, and to respond personal needs of them in the best way at the place and the time desired with web-based training.

In this study, a web-based training module for web design and programming course were designed and with this module it is provided to students to access lecture notes at desired times and places, to make applications, to make trials and errors by seeing their results about the topics in the courses instantly, to solve questions which provide to them completing their mislearnings, and to compare notes with instructors. At the end of this study, the effect of this web-based training module on learning of students is investigated by assessing students' grades and their feedbacks.

Key words: web-based training, web design and programming

GİRİŞ

Son yıllarda internet ve internete erişim yolları çok gelişmiştir. Eskiden internete sadece bilgisayarlar ile ulaşılabilirken şimdi tabletler, akıllı telefonlar ve smart tv'ler gibi cihazlarla da erişilebilmektedir. Bu da uzaktan eğitimin bu kanallarla da yapılmasına sebep olmuştur(Desai vd., 2009).

Eđitim olanaklarını g¼c¼lendirmek, daha verimli hale getirmek amacıyla, geliřmiř ve geliřmekte olan ¼lkeler eđitim sistemlerini teknolojik geliřmeler ıřıđında yeniden inřa etmiřler ve bireylerin istedikleri yerden, istedikleri zamanda, diledikleri kadar tekrar ederek, diledikleri kadar uygulama yaparak ¼đrenmelerine olanak tanıyan, uzaktan eđitimin bir modeli olan Web tabanlı eđitim (WTE) uygulamalarını kullanmaya bařlamıřlardır.

WTE, daha ¼nceden saptanmıř hedeflerin, ¼đrencilere kazandırılabilmesi i¼in, internet ¼zerinde oluřturulmuř, planlı ve s¼reli bir eđitim řekli olarak tanımlanabilir.

¼lkemizde de eđitim alanında yeni geliřmeler yařanmakta ve ¼đretmen merkezli ¼đrenmenin aksine ¼đrenci merkezli, ¼đrencilerin derslere daha aktif katıldıđı, kendi ihtiya¼larını belirleyip, belirli bir plan i¼erisinde eđitimini s¼rd¼rd¼kleri eđitim anlayıřı benimsenmiřtir. (MEB, 2013).

¼đretim programlarının, Biliřim Teknolojileri (BT) destekli ¼đretime uyumlu hale getirilerek eđitsel e-i¼eriklerin oluřturulacađı bu proje ile WTE' nin ¼nemi ve ihtiya¼ı vurgulanmaktadır.

Bu ¼alıřmada Anadolu Teknik Liseleri Biliřim Teknolojileri Alanında, 11. ve 12. sınıf ¼đrencilerine okutulan Web Tasarımı ve Programlama (WTP) dersinin ¼đretimine destek olacak bir WTE mod¼l¼ oluřturulmuřtur. Hazırlanan WTE mod¼l¼nde, ¼đrencilere WTP dersi i¼in konular oluřturularak, WTP dersinin yıllık planı ¼erçevesinde ¼đrencilerin yararlanmalarına izin verilmiřtir. Ders ¼đretmeninin yıllık planına g¼re anlattıđı derslere katkı sađlayacađı uygulamalar ve ders notları bu mod¼l i¼erisinde yer almaktadır. Mod¼lde ¼đrencinin hi¼bir yardımcı programa gerek duymadan yazarak ve hemen sonu¼larını g¼rd¼đ¼ bir Java platformu bulunmaktadır. ¼đrencilerin sisteme giriř ve ¼ıkıř zamanları, konuları tamamlayıp tamamlamadıkları, konuların hangi kısımlarında ne kadar zaman harcadıkları, hangi konularda zorlandıkları, hangi soruları ne kadar zamanda ¼zebildikleri, en ¼ok yanlıř yaptıkları uygulamalar gibi pek ¼ok veri kayıt altına alınmakta ve ders ¼đretmenin bu verileri y¼netici sayfasından detaylıca inceleyebildiđi, ¼đrenci-¼đretmen ve ¼đretmen g¼zetiminde ¼đrenci-¼đrenci iletiřimin sađlandıđı bir sistem oluřturulmuřtur. Sistemdeki t¼m kodlar C# programlama dili kullanılarak oluřturulmuřtur.

Oluřturulan WTE mod¼l¼ 11. Sınıf ¼đrencilerinden se¼ilen 12 ¼đrenciye a¼ılarak deney grubu oluřturulmuř, bu gruba alınmayan ve bir ¼nceki eđitim ¼đretim yılında WTP dersini aynı ¼đretmen ve aynı yıllık plan ile alan ¼đrenciler ile de kontrol grubu oluřturulmuřtur.

¼alıřmanın sonunda ¼đrencilerden gelen geri bildirimler ve ders ge¼me notları deđerlendirilerek, hazırlanan bu WTE mod¼l¼n¼n ¼đrenme ¼zerine etkisi incelenmiřtir.

Y¼NTEM

Web Tabanlı Eđitim

Web Tabanlı Eđitim (WTE)' in anlamı ¼zerine pek ¼ok g¼r¼ř bildirilmiřtir. Manzanares (2004), WTE sistemlerini, geliřen web teknolojileri ve bilgisayar konferans sistemleri sayesinde mekân ve zamandan bađımsız bir řekilde ¼đrencilerin birlikte ¼alıřmasına olanak veren oluřumlar olarak tanımlamaktadır

Web Tabanlı Eđitimde Bulunması Gereken ¼zellikler

WTE' lerin web ¼zerindeki basit eđitim i¼eriklerinden ayrılabilmesi i¼in sahip olması gereken temel ¼zellikler vardır. Bu ¼zellikler eđitim sisteminin amacına ve hedef kitlesine g¼re kimi zaman deđeriklikler g¼sterse de genel hatlarıyla ařađıdaki fonksiyonları i¼ermelidir.

- Kullanıcıların tanımlanması ve y¼netilmesi
- Ders i¼eriklerinin hazırlanması
- Derslerin y¼netilmesi
- ¼đrenciye ¼zel programların a¼ılması
- ¼dev ve proje verilmesi/teslimi
- Sınav ve testlerin hazırlanması ve uygulanması
- ¼đrenci davranıřlarının izlenmesi ve incelenmesi
- ¼đrencilerin bařarı durumlarının deđerlendirilmesi
- Etkileřimli iletiřim ortamlarının oluřturulması ve y¼netilmesi (Topuz, 2010)(Al vd., 2004).

Web Tasarımı Ve Programlama Dersi

Tasarımda dikkat edilecek temel ilkeler, HTML dili komutlarını kullanma, web tasarım editörünü ve stil şablonlarını kullanarak web sayfası tasarımı yapma, betik dilini kullanma ve etkileşimli web uygulamaları için programlar hazırlama ile ilgili konularda gerekli bilgilerin verildiği derstir. Bu derste öğrenciye; HTML dili komutları ve/veya web tasarım editörü yardımıyla web sayfaları oluşturma, programlama kodlarını kullanarak etkileşimli web uygulamaları yapma yeterliklerini kazandırmak amaçlanmaktadır(TTKB, 2006).

BULGULAR

Hazırlanan WTE Modülü üç kısımdan oluşmaktadır. Bunlar tüm verilerin saklandığı ortak veritabanı ve bu veritabanını kullanan, öğretmen tarafından tüm ayarlamaların yapıldığı, istatistiklerin incelenebildiği sunucu yazılımı ile öğrencilere, sistemde var olan derslere erişme ve bu derslerden faydalanma haklarının verildiği istemci yazılımdır.

WTE Modülü içerisindeki önemli özelliklerden birisi de hem öğrencilerin birbiri ile hem de öğretmen ile haberleşme imkânının bulunmasıdır. Ancak tüm haberleşme trafiği ders öğretmeni tarafından gözlemlenebilmektedir.

WTE Modülündeki dersler öğretmenin belirleyeceği takvime göre öğrencilerin kullanımına açılmaktadır. Sisteme giren öğrenciler bu takvim içerisindeki derslerin ders notlarına erişebilmektedirler. Dersle ilgili uygulamalar yaparak dersi daha iyi kavramaları sağlanmaktadır. Ders notlarından elde ettikleri bilgiler ve uygulamalardan edindikleri tecrübelerden sonra öğrenciler değerlendirmeye alınmaktadır. Dersin değerlendirmesinde başarılı olunursa ders tamamlanmış olarak işaretlenmektedir. Eğer başarılı olunamaz ise ders değerlendirme işlemi, ders tamamlanana kadar tekrar etmektedir. Gerek dersin tamamlanması gerekse tamamlanamaması durumlarında da derse ait uygulama ekranı ve ders notları her daim öğrenciye açık tutulmaktadır. Dersin tamamlanması durumunda ise dersin değerlendirme soruları yeniden çözülebilecek şekilde öğrenciye sunulmaktadır. Bu süreç sistemdeki tüm dersler tamamlanana kadar, zamanı gelen ders için devam etmektedir.

Sunucu (Server) Yazılımı

Gerçekleştirilen uygulamada tüm ayarların yapıldığı ve sonuçların gözlemlendiği bölümdür. Yönetim bölümü sadece öğretmen tarafından kontrol edilmekte olup öğrencilerin girişine kapalıdır.

Sunucu Yazılımının Çalışması Ve Kullanılması

Bu bölümde öğretmene, ders başlangıç - bitiş tarihlerini belirleyebilme, sisteme öğrenci ekleyebilme, öğrenci bazında bireysel istatistikleri takip edebilme, sınıfın gelen istatistiğini gözlemlenebilme, gereken öğrenciye yaptırım uygulayabilme ve mesaj trafiğini kontrol edebilme hakları tanımlanmıştır.

Bireysel İstatistikler Ve Yaptırımlar

WTE modülünde kendisine tanımlanan ve süresi içerisinde tamamlanması gereken derslerde öğrenciler dersin notlarını okumalı, kendin yap bölümünde uygulamalar yapmalı, varsa uygulama sınavına katılmalı ve son olarak bölüm sonu değerlendirme sorularını çözmelidir.

Öğretmen her bir öğrencinin WTE modülündeki ilerleyişini ders bazında Şekil 1’ de gösterilen öğrenci istatistik sayfası ile görebilmektedir.

The screenshot shows a web interface for student statistics. At the top, there is a search bar with 'Öğrenci Adı Soyadı: Mustafa S...' and 'Konu Başlığı: 3 HTML Temel Etiketleri'. Below this, a table displays performance data for a student named Mustafa. The table has columns for 'SORULAR' (1-11) and 'PUAN'. The data is as follows:

SORULAR	1	2	3	4	5	6	7	8	9	10	11	PUAN
Doğru şık	A	D	B	A	B	B	A	A	D	C	C	
Öğrencinin Verdiği Cevaplar	A	C	B	B	A	A	A	A	B	C	C	10
	A	D	B	C	A	B	A	A	B	C	C	17
	A	D	B	B	B	B	A	B	D	A	C	19
	A	D	B	A	B	B	A	A	D	C	C	26

Şekil 1. İstatistik Penceresi

Sınıfın Genel İstatistikleri

WTE modülünü alan tüm öğrencilerin genel olarak istatistikleri grafiksel olarak gözlemlenebilmektedir. Sadece öğretmen kullanıcısının erişmesine izin verilen genel durum grafikleri öğrencilerin derslere katılım gerçekleştirmeleri ile eş zamanlı olarak değişiklik göstermektedir.

İstemci (Client) Yazılımı

İstemci yazılımı WTE Modülünün öğrenciler tarafından kullanılan yüzüdür. Bu kısım, derslere ait kaynak notlar, uygulama ekranı ve değerlendirme sınavından oluşmaktadır. Bu yazılım ile öğrencilere, sistemde var olan derslere erişme ve bu derslerden faydalanma hakları verilmiştir. İstemci yazılımının genel mimarisi Şekil 2’ de gösterilmiştir.

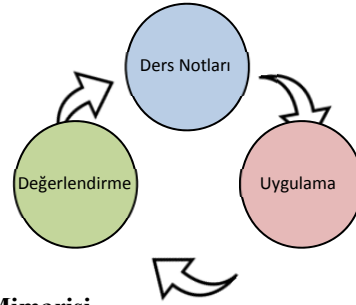

Şekil 2. İstemci Yazılımının Genel Mimarisi

Öğrenci İşlemleri

Sisteme giren öğrenci, WTE modülünü kullanmak üzere öğrenci ana sayfasına ulaşır. Bu sayfada öğrenciye, sistemde var olan tüm derslerin listesi, WTE modülündeki ilerleyişini gösteren bilgi çubuğu, sistemdeki derslerin tamamlanma oranı, şimdiye kadar topladığı puan bilgisi ve içerisinde, öğretmenine ve arkadaşlarına mesaj gönderebileceği, öğretmeninden ve arkadaşlarından gelen mesajları okuyabileceği ve şifresini değiştirebileceği bir menü sunulmaktadır. Öğrenci ana sayfası Şekil 3’ de gösterilmiştir.

KONU	BAŞLAMA TARİHİ	BİTİŞ TARİHİ
1. Web Tasarımda Temel İlkeler	17.09.2012	24.09.2012
2. İnternet Ortamı ve Web Tasarımı	25.09.2012	30.09.2012
3. HTML Temel Etiketleri	01.10.2012	07.10.2012
4. Listeleme Etiketleri	08.10.2012	14.10.2012
5. Metin ve Görünüm Düzenleme Etiketleri	15.10.2012	21.10.2012

Şekil 3. Öğrenci Ana Sayfası

Derslerin Kaynak Notları

Hazırlanan WTE Modülü içerisindeki tüm derslerde, seçilen derse ait kaynak notlar bulunmaktadır. Bu kaynak notlar MEB tarafından hazırlanmış WTP dersinin modülleri ve ders öğretmenin hazırladığı ders notlarıdır. Bu notların içerisinde bilgi ve örnekler bulunmakta olup uygulamanın öğrenci tarafından “Kendin Yap” bölümünde yapılması istenmektedir.

Derslerin Kendin Yap Bölümü

WTE modülünün en önemli özelliği öğrencilerin dersler ile ilgili uygulama yapmalarını sağlayan kendin yap bölümüdür. Kendin yap bölümü Şekil 4’ de gösterilen, bir tarafta kodların yazıldığı, bir tarafta da sonuçlarının gösterildiği ikiye bölünmüş bir pencere olup gerçek zamanlı çalışan bir yapıya sahiptir.

Bu bölümde öğrenci ikiye bölünmüş ekranın, üst kısmına kodları yazmakta ve bu kodların sonuçlarını, her bir tuşa bastıkça aşağıdaki diğer kısımda hemen görmektedir.



Şekil 4. Kendin Yap Bölümünün Çalışması

Derslerin Uygulama Sınavları

WTE modülünün içerisinde yer alan derslerde kendin yap bölümlerinin dışında öğrencilere uygulama sınavları sunulmaktadır. Öğrenciye yöneltilen uygulama sorularında boş bırakılan yerlerin öğrenci tarafından doğru olarak doldurulması istenmektedir. Öğrencinin cevaplarını vermesi ile uygulama sınavı cevap ekranında, doğru olarak doldurulan boşluklar yeşil renkle boyanırken, yanlış cevap verilen alan kırmızı renkle işaretlenmektedir.

Derslerin bölüm sonu değerlendirme sınavları

WTE modülü içerisindeki tüm dersler bölüm sonu değerlendirme sınavlarına sahiptir. Modül içerisindeki derslerin tamamlanmasının şartı öğrencinin bu bölüm sonu değerlendirme sınavından yeterli puanı almasıdır.

SONUÇ

Bu çalışma, uygulandığı gruptaki öğrencilerin, sözlü ve proje notları hariç ders geçme notlarına göre değerlendirildiğinde; sistemin kullanım oranı ile öğrencinin ders geçme başarısının bir biri ile doğru orantılı olduğu, sistemi en çok kullanan öğrencinin ders geçme notlarında en yüksek sonucu aldığı görülmüştür.

Çalışma, uygulandığı gruptaki ve diğer öğrencilerin ders geçme notları ile kıyaslanıp değerlendirildiğinde; WTE Modülü uygulanan grubun sözlü ve proje notları hariç, yazılılardan aldıkları notların aritmetik ortalaması 51,5 iken WTE Modülü uygulanmadan derslerine devam eden öğrencilerin oluşturduğu diğer grubun ortalamasının 43,15 olduğu görülmüştür. Dolayısıyla WTE Modülü uygulanan grubun WTP dersindeki başarısında %19,35 puanlık bir artış görülmüştür.

WTP dersi için hazırlanan ve dersin öğrenilmesine olan etkisinin araştırıldığı bu çalışmada, gerek anket sonuçlarına, gerek öğrencilerin ders geçme notlarına ve gerekse diğer grup ile karşılaştırılma sonuçlarına bakıldığında, hazırlanan WTE Modülünün WTP dersinin öğrenilmesine olumlu yönde etki ettiği görülmüştür.

Hazırlanan WTE Modülünün WTP dersi için kullanılabilir olduğu sonucuna varılmıştır.

KAYNAKLAR

- Al, U., Madran, R.,O., (2004). Web Tabanlı Uzaktan Eğitim Sistemleri: Sahip Olması Gereken Özellikler ve Standartlar. *Bilim Dünyası*, 5(2), 259-271.
- Desai, G.,C., Shinde, N.,S., (2009). Web Based Education in India: A Changing Scenario, 2009 *Second International Conference on Computer and Electrical Engineering*, 28-30 December, Dubai, 262-265.
- Fiş Erümit, S., (2011). Web Tabanlı Uzaktan Eğitimde Ders Materyali Tasarımı, Uygulaması ve Materyal Tasarım Kriterlerinin Belirlenmesi. *Karadeniz Teknik Üniversitesi, Fen Bilimleri Enstitüsü, Yüksek Lisans Tezi*, 123s, Trabzon.
- Manzanares, M.G., (2004). Attitudes of Counseling Students' Use of Web-Based Instruction for Online and Supplemental Instruction in a Master's Degree Program of Study. *Colorado State University, Doctoral Thesis*, 148p, Colorado.
- MEB, (2013). Erişim Tarihi:26.04.2013. <http://fatihprojesi.meb.gov.tr/tr/icerikincele.php?id=6>
- Topuz, F., (2010). Veri Yapıları ve Algoritma Dersi İçin Sanal Laboratuar Uygulaması. *Afyon Kocatepe Üniversitesi, Fen Bilimleri Enstitüsü, Yüksek Lisans Tezi*, 65s, Afyonkarahisar.
- TTKB 269, (2006). Meslekî ve Teknik Eğitim Okul ve Kurumlarının 42 Alanına/194 Dalına Ait Haftalık Ders Çizelgeleri ile Modüler Çerçeve Öğretim Programları. *Talim ve Terbiye Kurulu Başkanlığı*, Ankara.
- Yeniad, M., (2006). Uzaktan Eğitimde Kullanılmak Üzere Web Tabanlı bir Portal Yazılımı Gerçekleştirme. *Çukurova Üniversitesi, Sosyal Bilimler Enstitüsü, Yüksek Lisans Tezi*, 154s, Adana.

SINIF ÖĞRETMENLİĞİ ÖĞRENCİLERİNİN TEKNOLOJİK PEDAGOJİK ALAN BİLGİSİ ÖZ YETERLİK DURUMLARININ BELİRLENMESİ

DETERMINATION OF CLASSROOM TEACHER TRAINING CANDIDATES' SELF SUFFICIENCY IN TECHNOLOGICAL PEDAGOGICAL CONTENT KNOWLEDGE

Nazmiye BAŞER

Murat DEMİRBAŞ

Harun ÇELİK

Kırıkkale Üniversitesi Eğitim Fakültesi

ÖZET: Bu araştırmanın amacı üniversite öğrencilerinin teknolojik pedagojik alan bilgisi öz yeterlik algılarını belirlemektir. Çalışmada survey yöntemi kullanılmıştır. Öğrencilerin pedagojik alan bilgisi öz yeterlik durumunu belirlemek için, Kaya vd. (2011) tarafından Türkçe'ye uyarlanan, "TPAB" anketi kullanılmıştır. Elde edilen verilerin analizi SPSS-21 istatistik programı aracılığıyla yorumlanmıştır. Çalışmada betimsel istatistiksel analizlere ek olarak bağımsız gruplar t-testi ve ANOVA testi yapılmıştır. Araştırmanın örneklemini Kırıkkale Üniversitesi Eğitim Fakültesi'nde öğrenim görmekte olan 1. 2. ve 3 sınıf öğrencilerinden toplam 391 Sınıf Öğretmenliği bölümü öğrencileri oluşturmaktadır. Analiz sonuçlarına göre öğretmen adaylarının cinsiyet değişkeniyle ilgili olarak öz yeterlik seviyeleri arasında pedagojik bilgi (PB), alan bilgisi (AB) ve pedagojik alan bilgisi (PAB) alt boyutlarında kız öğrenciler lehine anlamlı fark olduğu görülmektedir. Teknolojik bilgi(TB) boyutunda ise erkek öğrenciler lehine anlamlı bir farklılık olduğu sonucuna ulaşılmıştır. Ayrıca sonuçlara göre, öğretmen adaylarının öz yeterlik seviyeleri arasında sadece teknolojik bilgi alt boyutlarında okudukları sınıfa göre anlamlı bir farklılık görülmüştür.

Anahtar sözcükler: Öz-yeterlik, Teknolojik Pedagojik Alan Bilgisi, Fen öğretimi, Sınıf öğretmen adayları

ABSTRACT: The aim of the study is to determine university students' sense of self sufficiency in technological pedagogical content knowledge. Survey method was used in the study. To determine students' self sufficiency in pedagogical content knowledge, the survey of "TPAB" which was adapted by Kaya (2011) et al. was used. The gathered data was interpreted using SPSS-21 Program. In addition to descriptive statistical analyses, independent t-test and ANOVA were applied. The sample of the study constituted of 391 students who attend 1.,2, and 3. grades in the department of Classroom Teacher Training in Kırıkkale University. As a result of analysis, it was found that there is a significant difference between teacher candidates' gender and self-efficiency in the sub-dimensions of pedagogical content knowledge and field knowledge for girls. In the dimension of technological knowledge, an important difference was found for boys. Moreover, it was found that grades were only an important factor in the sub-dimension of technological knowledge.

Key words: Self-sufficiency, technological pedagogical content knowledge, science teaching, classroom teacher training candidates.

GİRİŞ

İnsan yaşamının teknolojiyle biçimlenmesinin hızlı bir gelişme gösterdiği yirmi birinci yüzyılda, teknolojinin kullanım alanlarından birisi de eğitimidir. Öğrenme kuramlarındaki gelişmeler, eğitimde teknoloji kullanımının gerekliliğini ortaya koymaktadır. Özellikle her öğretmenin mesleğinde başarılı olabilmesi için iletişimde ve eğitimde kullanılan araç, yöntem ve tekniklerin neler olduğunu, bunların birbirleriyle ilişkilerini, belirli hedef davranışları oluşturacak yaşantıların nasıl seçileceğini ve bunları kazandıracak öğretim durumlarının nasıl düzenleneceğini bilmesi bir zorunluluk olarak ortaya çıkmaktadır.(Çilenti 1984; Akt:Yaman, 2007). Bu doğrultuda Shulman (1986) tarafından literatüre kazandırılan pedagojik alan bilgisi (PAB)ne teknoloji bilgisi boyutu eklenerek yapılandırılan Teknolojik Pedagojik Alan Bilgisi (TPAB) ön plana çıkmaktadır. Bu yapılanmada teknoloji, pedagoji ve alan bilgisinin birleştirilmesi ile oluşan 7 bilgi alanı yer almaktadır. Bunlar; Alan bilgisi, Pedagoji bilgisi, Teknoloji bilgisi, Pedagojik alan bilgisi, Teknolojik alan bilgisi, Teknolojik pedagoji bilgisi ve Teknolojik pedagojik alan bilgisi şeklindedir(Mishra ve Koehler, 2006; Akt. Horzum, 2011). Bu yapı şekli 1'de yer almaktadır(Mishra ve Koehler, 2006; Akt: Konokman vd. 2013).

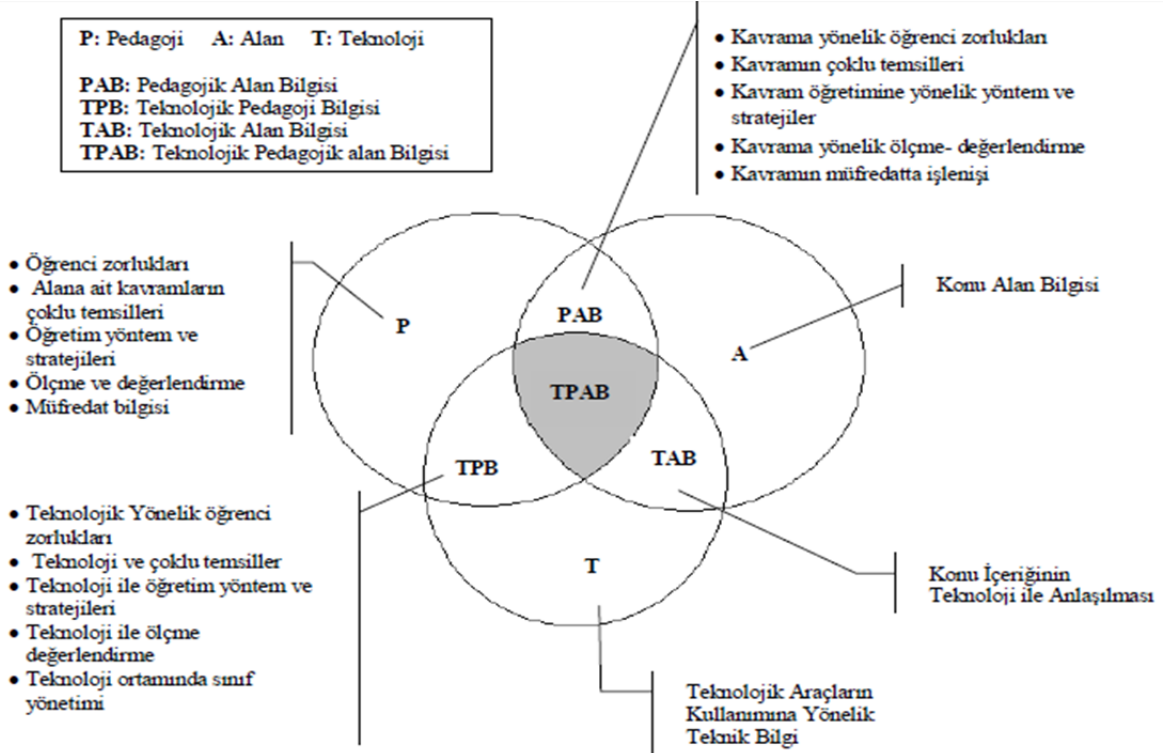

Şekil 1: TPAB'nin Bileşenlerinin Kapsam ve İçerikleri

Bu model öğretmenlere, öğretmen eğitimcilerine sınıflarda teknolojinin kullanımı ve bilgilerini yeniden değerlendirmelerine neden olmuştur(Bal ve Karademir, 2013). TPAB sinin bileşenleri:

Alan Bilgisi (AB): Alanda yer alan ve öğrenilecek ya da öğretilecek bir konudur.

Pedagojik Bilgi (PB): Öğretim yaklaşımlarının ve öğretilecek konuya hangi yaklaşımın uygun olacağını bilgisidir.

Teknolojik Bilgi (TB): Kara tahta, kitap gibi standart veya dijital video, hikâyeleme, internet gibi daha gelişmiş teknolojiler hakkındaki bilgisidir.

Pedagojik Alan Bilgisi (PAB): Konunun (alan) öğretimi bilgisidir.

Teknolojik Pedagojik Bilgi (TPB): Teknolojilerin öğrenme ve öğretim ortamlarında kullanmanın ve bu teknolojilerin öğretimi nasıl değiştireceğinin bilgisidir.

Teknolojik Alan Bilgisi (TAB): Teknoloji ve alan bilgisinin karşılıklı olarak ilişkili olduğu bilgisidir.

Teknolojik Pedagojik Alan Bilgisi (TPAB): Teknoloji, pedagoji ve alan bilgisinin bileşiminden oluşan ve bu bilgilerin ayrı ayrı formunun çok ötesinde bilgi bütünüdür.

TPAB gelişmiş olan öğretmenler sınıflarında bilgiyi daha çok teknolojik araçları kullanarak sunabilir, öğrencilerinin anlama ve düşünme seviyelerinin farkına varabilirler. Öğrencinin bilişsel seviyesini anlayan ve bu doğrultuda açıklamalar yapan örnekler veren, benzetmeler ve farklı öğretim stratejileri kullanan öğretmenler, daha iyi bir şekilde bilgiyi sunabilirler (Bal ve Karademir, 2013). Bu nedenle öğrenme-öğretme sürecinde öğretmenlerin birçok işini kolaylaştırmada teknolojinin önemi yadsınamaz. Bu yüzden öğretmen adaylarımızın bilgi ve iletişim teknolojilerini doğru ve etkili bir şekilde kullanmaları, mesleki hayatlarında etkin olarak kullanmaları oldukça önemlidir.

Bu çalışmanın amacı, Eğitim fakültelerinin sınıf öğretmenliği bölümünde okuyan 1.,2. Ve 3. sınıflarındaki öğrencilerin teknolojik pedagojik alan bilgileri algılarını farklı değişkenler (sınıf, cinsiyet) açısından incelemektir.

Araştırma Soruları

1. Sınıf öğretmen adaylarının sahip oldukları TPAB öz-yeterlik seviyeleri, cinsiyetleri açısından anlamlı bir farklılık göstermekte midir?
2. Sınıf öğretmen adaylarının sahip oldukları TPAB öz-yeterlik seviyeleri sınıf seviyeleri açısından anlamlı bir farklılık göstermekte midir?
- 3.

YÖNTEM

Mevcut araştırmada Kırıkkale Üniversitesi'nin İlköğretim Bölümü Sınıf Öğretmenliği Ana Bilim Dalı'nda öğrenim gören 1., 2., ve 3. sınıflardaki öğretmen adaylarının teknolojik pedagojik alan bilgisi (TPAB) konusunda özyeterlik seviyeleri arasındaki ilişki belirlenmeye çalışıldığı için tarama modeli kullanılmıştır. Tarama modeli, geçmişte ya da halen var olan bir durumu var olduğu şekliyle betimlemeyi amaçlayan bir araştırma yaklaşımıdır (Balci, 2001; Karasar, 2009).

Çalışma Grubu

Bu araştırmanın çalışma grubunu 2012-2013 eğitim-öğretim yılında Kırıkkale Üniversitesi Eğitim Fakültesi Sınıf Öğretmenliği Bölümü 1.,2., ve 3. sınıfta öğrenim gören 391 sınıf öğretmen adayları oluşturmaktadır.

Veri Toplama ve Analizi

Veri toplama aracı olarak, Kaya vd. (2011) tarafından Türkçeye uyarlanan teknolojik pedagojik alan bilgisi (TPAB)" adlı likert bir ölçek kullanılmıştır. 24 likert maddeden oluşan anket, pedagojik bilgi (PB), teknolojik bilgi (TB), alan bilgisi (AB), teknolojik alan bilgisi (TAB), pedagojik alan bilgisi (PAB), teknolojik pedagojik bilgi (TPB) ve teknolojik pedagojik alan bilgisi (TPAB) olmak üzere toplam yedi faktörden oluşmaktadır. Çalışmada TPAB'ın yedi bileşeni için "Çok kötü-Çok iyi" şeklinde 5'li likert yapı kullanılmıştır.

Verilerin Analizi

Sınıf öğretmen adaylarının TPAB'ı oluşturan bileşenler açısından sahip oldukları öz yeterlik seviyelerinin belirlenmesinde ve kişisel bilgiler anketindeki verilerin analizinde, betimsel istatistik testler olan yüzde ve frekans analizleri yapılmıştır. Ayrıca öğretmen adaylarının sahip oldukları TPAB öz-yeterlik seviyelerinin, cinsiyetleri ve öğrenim gördükleri sınıf değişkenleri açısından anlamlı bir farklılık gösterip göstermediğini belirlemek için bağımsız gruplar t-testi uygulanmıştır. TPAB öz yeterlik seviyelerinin bu değişkenler açısından bir farklılık gösterip göstermediğini belirlemek için de tek-yönlü ANOVA analizi kullanılmıştır. Elde edilen verilerin analizi SPSS-21 istatistik programı aracılığıyla yorumlanmıştır.

BULGULAR

Bu bölümde, araştırma sonuçlarına ilişkin elde edilen bulgular tablolar halinde sunulmuş ve değerlendirilmiştir.

Tablo1: Araştırmaya Katılan Öğrencilerin Cinsiyet Durumlarına Göre Dağılımı

Cinsiyet	f	%
Kız	295	75,4
Erkek	96	24,6
TOPLAM	391	100

Tablo 1 incelendiğinde; araştırmaya katılan sınıf öğretmenliği bölümü öğrencilerinin % 75,4'ünün kız(295) ve % 24,6'sının da erkek(96) öğrencilerden oluştuğu görülmektedir. Araştırmaya katılanların çoğunluğunu kız öğrenciler oluşturmaktadır.

Tablo2: Araştırmaya Katılan Öğrencilerin Okudukları Sınıflara Göre Dağılımı

Sınıf	f	%
I.sınıf	199	50,9
II.sınıf	125	32,0
III.sınıf	67	17,1
TOPLAM	391	100

Tablo 2 incelendiğinde; araştırmaya katılan sınıf öğretmenliği öğrencilerin % 50,9'unu I. Sınıf öğrencileri(199), % 32'sini II.sınıf öğrencileri(125) ve %17,1'ini ise III. Sınıf öğrencileri(67) oluşturmaktadır.

Tablo3: Araştırmaya Katılan Öğrencilerin Okudukları Sınıfların Cinsiyete Göre Dağılımı

Sınıf	Cinsiyet	f	%
I.sınıf	Kız	146	73,4
	Erkek	53	26,6
	TOPLAM	199	100
II.sınıf	Kız	100	80,0
	Erkek	25	20,0
	TOPLAM	125	100
III.sınıf	Kız	49	73,1
	Erkek	18	26,9
	TOPLAM	67	100

Tablo 3 incelendiğinde; araştırmaya katılan sınıf öğretmenliği I. sınıf öğrencilerinin 146'sı kız, 53'ü erkek; II. Sınıf öğrencilerinin 100'ü kız, 25'i erkek; III. Sınıf öğrencilerinin 49'u kız, 18'i erkek öğrencilerden oluştuğu görülmektedir.

Tablo4: Araştırmaya Katılan Öğrencilerin Cinsiyet Durumlarına Göre TPAB Özyeterliklerine İlişkin Bağımsız Gruplar İçin t -Testi Sonuçları

Değişkenler	Cinsiyet	N	\bar{X}	S	sd	t	p
Genel Toplam	Kız	295	89,37	12,35	389	1,391	.165
	Erkek	96	87,38	11,35			

TPAB puan ortalamalarında kız öğretmen adaylarının puanlarının ortalamaları $\bar{X} = 89,37$ erkek öğretmen adaylarının ortalamaları $\bar{X} = 87,38$ 'dir. Ayrıca her iki grup için standart sapmalar sırasıyla $S_s = 12,35$ ve $S_s = 11,35$ olarak hesaplanmıştır. Hesaplanan t değeri ve %95 güven aralığına göre ($p < .05$); kız ve erkek öğretmen adaylarının genel toplamdan aldıkları puanlar cinsiyet değişkeni açısından incelendiğinde gruplar arasında anlamlı bir farklılık olmadığı anlaşılmaktadır. [$t(389) = 1,391$ ve $p > .05$].

Tablo5: Sınıf Öğretmenliği Öğrencilerinin Sahip Oldukları TPAB Özyeterlik Seviyelerinin Cinsiyetleri Açısından t-Testi Analizi Sonuçları

Değişkenler	Cinsiyet	N	\bar{X}	S	sd	t	p
Pedagojik Bilgi	Kız	295	11,78	1,847	389	2,391	,017*
	Erkek	96	11,27	1,695			
Teknolojik Bilgi	Kız	295	9,22	2,557	389	-3,481	,001*
	Erkek	96	10,28	2,736			
Alan Bilgisi	Kız	295	11,87	1,869	389	3,013	,003*
	Erkek	96	11,20	1,961			
Teknolojik Alan Bilgisi	Kız	295	10,62	2,088	389	-,569	,569
	Erkek	96	10,75	1,880			
Pedagojik Alan Bilgisi	Kız	295	15,33	2,458	389	2,999	,003*
	Erkek	96	14,46	2,504			
Teknolojik Pedagojik Bilgi	Kız	295	15,22	2,947	389	1,824	,069
	Erkek	96	14,61	2,498			
Teknolojik Pedagojik Alan Bilgisi	Kız	295	15,35	2,468	389	1,807	,072
	Erkek	96	14,82	2,445			

Tablo 5'e göre sınıf öğretmenliği öğrencilerinin sahip oldukları TPAB öz yeterlik seviyeleri cinsiyet değişkeni açısından incelendiğinde; kız öğrenciler ile erkek öğrenciler arasında pedagojik bilgi (PB), alan bilgisi (AB) ve pedagojik alan bilgisi (PAB) alt boyutlarında kız öğrenciler lehine anlamlı fark olduğu görülmektedir. ($p < .05$). Teknolojik bilgi boyutunda ise erkek öğrenciler lehine anlamlı bir farklılık olduğu görülmektedir.

Tablo6: Sınıf Öğretmenliği Öğrencilerinin Sahip Oldukları TPAB Özyeterlik Seviyelerinin Okudukları Sınıfa İlişkin Betimsel İstatistik Sonuçları

Değişkenler	Cinsiyet	N	\bar{X}	SS
Pedagojik Bilgi	I. Sınıf	199	11,63	1,89
	II. Sınıf	125	11,56	1,85
	III. Sınıf	67	11,88	1,52
Teknolojik Bilgi	I. Sınıf	199	9,74	2,79
	II. Sınıf	125	9,45	2,40
	III. Sınıf	67	8,73	2,46
Alan Bilgisi	I. Sınıf	199	11,81	1,83
	II. Sınıf	125	11,52	2,05
	III. Sınıf	67	11,71	1,84
Teknolojik Alan Bilgisi	I. Sınıf	199	10,76	2,08
	II. Sınıf	125	10,51	1,94
	III. Sınıf	67	10,53	2,07
Pedagojik Alan Bilgisi	I. Sınıf	199	15,16	2,53
	II. Sınıf	125	14,94	2,43
	III. Sınıf	67	15,28	2,50
Teknolojik Pedagojik Bilgi	I. Sınıf	199	15,16	2,96
	II. Sınıf	125	15,03	2,37
	III. Sınıf	67	14,82	3,32
Teknolojik Pedagojik Alan Bilgisi	I. Sınıf	199	15,27	2,63
	II. Sınıf	125	15,01	2,25
	III. Sınıf	67	15,43	2,35

Değişkenler	Varyansın Kaynağı	Kareler Toplamı	sd	Kareler Ortalaması	F	p
-------------	-------------------	-----------------	----	--------------------	---	---

Pedagojik Bilgi	Gruplar Arası	4,594	2	2,297	,691	
	Grup içi	1289,795	388	3,324		,502
	Toplam	1294,389	390			
Teknolojik Bilgi	Gruplar Arası	51,463	2	25,732	3,748	
	Grup içi	2664,102	388	6,866		,024*
	Toplam	2715,565	390			
Alan Bilgisi	Gruplar Arası	6,653	2	3,327	,910	
	Grup içi	1418,933	388	3,657		,404
	Toplam	1425,586	390			
Teknolojik Alan Bilgisi	Gruplar Arası	6,039	2	3,019	,726	
	Grup içi	1613,256	388	4,158		,484
	Toplam	1619,294	390			
Pedagojik Alan Bilgisi	Gruplar Arası	6,073	2	3,037	,487	
	Grup içi	2421,748	388	6,242		,615
	Toplam	2427,821	390			
Teknolojik Pedagojik Bilgi	Gruplar Arası	6,151	2	3,076	,377	
	Grup içi	3167,250	388	8,163		,686
	Toplam	3173,402	390			
Teknolojik Pedagojik Alan Bilgisi	Gruplar Arası	8,759	2	4,380	,717	
	Grup içi	2369,762	388	6,108		,489
	Toplam	2378,522	390			

Tablo7: Sınıf Öğretmenliği Öğrencilerinin Sahip Oldukları TPAB Özyeterlik Seviyelerinin Okudukları Sınıfa Göre ANOVA Sonuçları

Tablo7’deki ANOVA analizi sonuçlarına göre sınıf öğretmenliği öğrencilerinin teknolojik bilgi puanlarının ortalamaları arasında anlamlı bir farklılık bulunmuştur.($F=3,748$, $p<0,05$). Bu farklılığın hangi gruplar arasında olduğunu belirleyebilmek için yapılan Scheffe testi sonuçları tablo 8’de görülmektedir.

Tablo8: Sınıf Öğretmenliği Öğrencilerinin Sahip Oldukları Teknolojik Bilgi Boyutundaki Scheffe Testi Sonuçları

Grup	\bar{x}	Teknolojik Bilgi		
		Sınıf I	Sınıf II	Sınıf III
Sınıf I	9,74			*
Sınıf II	9,45			
Sınıf III	8,73			

Tablo 8’de görüldüğü gibi sınıf öğretmenliği I. sınıf öğrencilerinin teknolojik bilgi ($\bar{x}=9,74$) boyutunda sınıf öğretmenliği III. sınıf öğrencilerinin teknolojik bilgi ($\bar{x}=8.73$) boyutuna göre anlamlı bir farklılık göstermektedir.

SONUÇ

Araştırmanın sonuçlarına bakıldığı zaman öğretmen adaylarının genel olarak yüksek teknolojik pedagojik alan bilgisi (TPAB) öz yeterlik seviyelerine sahip oldukları görülmektedir. Yine araştırma sonuçları dikkate alındığında cinsiyet değişkeni ile öğretmen adaylarının TPAB öz yeterlik seviyelerinde farklılık olmadığı görülmektedir. Ancak öğretmen adaylarının TPAB bileşenlerinden en başarılı oldukları alan açısından cinsiyet değişkeni dikkate alındığında kız öğrenciler ile erkek öğrenciler arasında pedagojik bilgi (PB),alan bilgisi (AB) ve pedagojik alan bilgisi (PAB) alt boyutlarında anlamlı fark olduğu görülmektedir. Araştırmada erkek öğretmenlerin kendilerini teknolojik bilgi konusunda daha yeterli gördüğü söylenebilir. Buna karşın erkekler ve kızların teknolojik bilgi konusunda görüş puanları arasında anlamlı fark olmadığını da gösteren çalışmalar da mevcuttur. Ancak bu çalışmalarda da erkeklerin görüş puanlarının yüksek olduğunu görülmektedir (Ekici 2008;

Gezer ve Sevim, 2006); akt. Bal ve Karademir, 2013). Bu durum erkeklerin teknolojik gelişmeler konusunda daha ilgili olmaları ve bu konuya daha fazla zaman ayırmaları ile açıklanabilir. Ayrıca öğretmen adaylarının okudukları sınıf derecesi arttıkça sahip oldukları teknolojik bilgilerinde de artış olduğu görülmektedir. Bu durum ise teknolojik araçların eğitim alanında kullanılma durumu ile açıklanabilir. Bu noktadan hareketle öğretmen eğitiminde teknolojik pedagojik alan bilgisi olgusunu geliştirmek için, adaylara teknolojik araçların eğitim ortamında etkin kullanılabileceğini ve bunun önemi vurgulanmalıdır. Teknolojik araçların avantajları ve bunları kullanmada karşılaşılabilecekleri sıkıntıları tanımaları, bu sıkıntıları gidermede çözüm yolu üretebilecekleri bir eğitim süreci adaylara sağlanmalıdır. Alan eğitiminde kullanabileceği teknolojik araca hakim olan ve bu konuda olumlu tutumu olan bir öğretmen adayının gelecekte bu teknolojiyi dersinde kullanması muhakkaktır(Bilgin vd. 2012).

KAYNAKLAR

- Balcı, A. (2001). Sosyal bilimlerde araştırma yöntem, teknik ve ilkeler. Ankara: Pegem Yayıncılık.
Bal, M. S., & Karademir, N. (2013). Sosyal bilgiler öğretmenlerinin teknolojik pedagojik alan bilgisi (tpab) konusunda öz-değerlendirme seviyelerinin belirlenmesi:*Pamukkale Üniversitesi Eğitim Fakültesi Dergisi*,

- Sayı 34 (Temmuz 2013/II), ss. 15-32.*
- Bilgin, İ., & Tatar, E.; & Ay, Y. (2012). Sınıf öğretmeni adaylarının teknolojiye karşı tutumlarının teknolojik pedagojik alan bilgisi (TPAB)' ne katkısının incelenmesi: Erişim: 23 Nisan 2014
http://kongre.nigde.edu.tr/xufbmek/dosyalar/tam_metin/pdf/2392-30_05_2012-15_39_28.pdf
- Horzum, M. B. (2011). Web pedagojik içerik bilgisi ölçeği'nin türkçeye uyarlaması. *Elementary Education Online, 10(1), 257-272, 2011. İlköğretim Online, 10(1), 257-272, 2011.* [Online]: <http://ilkogretim-online.org.tr>
- Kaya, Z., & Özdemir, Y. T. & Emre, İ., & Kaya, N. O. (2011). *Bilişim teknolojileri öğretmen adaylarının teknolojik pedagojik alan bilgisi öz yeterlik seviyelerinin belirlenmesi.* 5th International Computer & Instructional Technologies Symposium, 22-24 September 2011 Fırat University, Elazığ- Turkey.
- Karasar, N. (2009). Bilimsel araştırma yöntemleri. *Ankara: Nobel Yayın Dağıtım.*
- Konokman, G., & Yelken, T., & Tokmak, H. (2013). *Sınıf öğretmeni adaylarının tpab'lerine ilişkin algılarının çeşitli değişkenlere göre incelenmesi: mersin üniversitesi örneği.* Kastamonu Eğitim Dergisi Mayıs 2013 Cilt:21 No:2
- Yaman, H. (2007). Türkçe öğretmeni adaylarının "öğretim teknolojileri ve materyal geliştirme" dersi bağlamında türkçe öğretiminde teknoloji kullanımına ilişkin yeterlilik ve algıları. *Hasan Ali Yücel Eğilim Fakültesi Dergisi Sayı 7 (2007-1), 57-71*

EXAMINATION OF VISUALS IN MIDDLE SCHOOL SCIENCE TEXTBOOKS

Hasan Ozgur KAPICI

Funda SAVASCI-ACIKALIN

Particulate nature of matter(PNM) is one of the crucial topics in science education owing to the fact that it constitutes fundamentals of many other subject such as chemical bonding and reactions,solutions and matter phases.For this reason,it is important to teach PNM effectively to middle school students.To teach the topic successfully,teachers and textbooks have vital roles through learning process.Textbooks are primary sources for most of teachers in classrooms(Chiappetta&Fillman,2007).Due to the fact that its importance in educational context,they should include accurate scientific knowledge as much as possible.Textbooks not only involve texts but also contain visuals.This is called multimedia learning which occurs when students receive information presented in more than one mode, such as in pictures and words(Mayer,1997).

On the other hand,Johnstone(1993) introduced three basic levels(macroscopic,submicroscopic and symbolic) in chemistry and Gabel(1993)emphasized that level of achievement in the science lectures,which include these three types of representations,is higher.While macroscopic level comprises things that can be observed by naked eyes,submicroscopic level involves that cannot be seen naturally such atoms,molecules and so on.Symbolic level implies that equations,symbols,etc.

In this study,researchers aimed to examine visuals in middle school textbooks and research questions were determined as below:

- 1)What kind of representations are there in the unit of PNM in middle school science textbooks?
- 2)In what degree are there relationships between text and visuals in the unit of PNM in middle school science textbooks?
- 3)Are there captions that were used for the representations appropriate in the unit of PNM in middle school science textbooks?

In the study,document analysis was used.1166 visuals in the 8 textbooks were examined.

Analyses of data are on progress.

Keywords: Multiple representations, Textbooks, Particulate Nature of Matter, Science Education

NON-MATHEMATICS STUDENTS' REASONING IN NON-ROUTINE CALCULUS TASKS

Ljerka Jukić MATIĆ
Department of Mathematics
University of Osijek
ljukic@mathos.hr

ABSTRACT: This paper investigates reasoning of first year non-mathematics students in non-routine calculus tasks. The students in this study were accustomed to imitative reasoning during their schooling in primary and secondary education. In order to move from imitative reasoning toward more creative reasoning, the non-routine tasks were implemented as the part of the calculus course. Using qualitative strategy in a form of interview, we examined reasoning of six students in the middle of the calculus course and at the end of the course. Analyzed data showed that creative reasoning develops slowly even when students are exposed to the non-routine tasks. Also, we have found several negative met-befores and met-afters affecting students' knowledge and interfering with the reasoning process.

Keywords: calculus, reasoning, non-mathematics students

INTRODUCTION

Society today highlights mathematical literacy as an important educational goal. Mathematical literacy means that one should possess certain mathematical competencies. Niss (2003) distinguishes eight, distinct and clearly recognizable competencies: thinking mathematically, posing and solving mathematical problems, modelling mathematically, reasoning mathematically, representing mathematical entities, handling mathematical symbols and formalisms, communicating in, with and about mathematics and making use of aids and tools. These mathematical competencies should be developed not only through primary and secondary education, but in tertiary education as well. This is surely in line with demands of industries and businesses worldwide; mathematics provides a powerful tool to understand, to investigate and to make predictions in the solution of a wide range of problems, therefore it is important to produce employees who are both mathematically capable and trained (Chinnappan et al., 2009). But, we can ask ourselves what competencies students are developing in tertiary education when they are given the same types of tasks in the exams as they have met in the mathematics courses. When it comes to exam requirements, students actually do expect this kind of situation to happen. Their expectations are anchored in previous accessible exams copies, and this is usually part of didactical contract between students and lectures (Lithner, 2010). The reasoning which students employ in such situations Lithner (2003) calls imitative reasoning. This kind of reasoning is founded on copying task solutions, for example by looking at a textbook example or remembering an algorithm. Examining final exams from the introductory calculus courses at Swedish universities, Bergqvist (2007) found that most of the tasks can be solved using imitative reasoning. Investigating teachers' view on the reasoning requirements in the calculus exams, Bergqvist (2012) found that teachers were concerned with the exam passing rate, therefore majority demanded imitative reasoning. The situation is no different in Croatian universities as well. Even though there are no published studies, browsing exams and course material accessible on the web pages of different Croatian universities, one can reach the similar conclusion, especially when it comes to calculus courses for non-mathematics students.

Lithner (2008) points out that even after many years of research, students still do inefficient rote thinking and rely on imitative reasoning. Guided with the aforementioned concerns, we examined reasoning of several non-mathematics students who have been exposed to non-routine calculus tasks. Our goal was to see how the non-routine tasks affected students' reasoning.

THEORETICAL FRAMEWORK

In the mathematics education literature, there can be found many definitions describing the term reasoning. Lithner (2008) defined reasoning as the line of thought that is adopted to produce assertions and to reach conclusions when solving tasks. It is not necessarily based on formal logic, nor restricted to proof. It may even be incorrect as long as there are some sensible reasons (to the reasoner) supporting it and can be seen as thinking

process, as the product of these processes, or as both. It can have characteristics of high and low quality. In this paper we adopt aforementioned definition of reasoning.

Lithner (2008) distinguishes two types of mathematical reasoning: imitative and creative mathematically founded reasoning. Everything that includes rote learning reasoning is in fact imitative reasoning, and the opposite reasoning is creative reasoning. Creative mathematically founded reasoning fulfills following criteria: novelty, plausibility, flexibility and mathematical foundation. *Novelty* includes new reasoning sequence that is created or recreated if forgotten. *Plausibility* can be described as using arguments to support the strategy choice and/or strategy implementation. *Flexibility* admits different approaches and adaptations to the situation and it does not suffer from fixation that hinders the progress. *Mathematical foundation* means the argumentation is founded on intrinsic mathematical properties of the component involved in the reasoning. Creative reasoning does not have to be a challenge as problem solving but conceptual understanding is deeply anchored in it, unlike in imitative reasoning.

Imitative reasoning consists of several different types of superficial reasoning. *Memorized Reasoning (MR)* is when the strategy choice is founded on recalling an answer and the strategy implementation consists of writing this answer down with no further consideration. *Algorithmic Reasoning (AR)* is implemented when the strategy choice involves recalling a certain algorithm (set of rules) for solving the given problem. The strategy implementation is trivial, straightforward once the rules are recalled. AR has several variants: familiar algorithmic reasoning, delimiting algorithmic reasoning and guided algorithmic reasoning. The strategy choice in *Familiar AR* is founded on recognizing the task as being familiar, which can be solved by a corresponding known algorithm. In *Delimiting AR*, an algorithm is chosen from a set that is delimited through surface relation with the task. Following the algorithm carries out the implementation of the strategy. If this implementation does not produce desired outcome, the algorithm is abandoned and a new one is chosen. In *Guided AR*, the reasoning is mainly guided by two types of sources that are external to the task. In person-guided AR, a teacher pilots the student's solution. In text-guided AR, the strategy choice is founded on identifying, in the task to be solved, similar surface properties to those in a text source (e.g., a textbook).

The main problem with algorithmic reasoning is not that students do not learn creative reasoning, but that they do not develop the conceptual knowledge necessary for learning different aspects of mathematics (Lithner, 2004). Cox (1994) argued that many first-year university students obtain good grades by concentrating on routine topics, instead of aiming at deep understanding of fundamental topics. Schoenfeld (1991) pointed out that while many teachers are trying to reduce complexity of mathematical concepts and processes, students are trying to cope with curriculum goals so they often use quicker short-cut strategies to learning and passing exams. Lithner (2008) claimed that the most frequent type of reduction of complexity is focused on algorithmic procedures that can solve advanced task and not using conceptual understanding or creative reasoning at all. He supported Tall's (1997) conclusion on "vicious circle" of procedural learning and teaching where, for example, calculus lecturers focus on the differentiation and integration on symbolic level and ask similar question in examinations.

Met-befores and met-afters

A met-before is a mental construct that person uses at a given time based on prior experiences (Tall, 2006). Using met-befores can sometimes be an advantage when person is learning a new mathematical concept and sometimes it can be an obstacle which causes severe difficulties. Hence, met-befores affect learning of new concepts, but new mathematical concepts may also affect older knowledge. Such mental constructs are called *met-afters* (Lima & Tall, 2008). Met-afters are those experiences met at the later time that affect the retention of old knowledge. Met-afters can also be both positive and negative, and the negative effect of some met-after shows fragility or inconsistency of the earlier learned knowledge.

New knowledge that builds on previous knowledge is much better remembered, but concepts that do not fit into earlier experience are learned temporarily and easily forgotten or not learned at all. According to McGowen and Tall (2010), this can be observed when student, for instance, is interested only in algorithmic reasoning, relying on well-established procedures or algorithms. If there is no conceptual meaning, this kind of knowledge is stored improperly and is very fragile when person tries to adapt it to new situation. This previous knowledge makes it difficult to understand new subject matter, since the student is trying to distinguish among accessible rules and is trying to imbed new knowledge into his fragmented knowledge structure.

Setting up the scene

The tasks that are given to students within some mathematics course can be categorized as routine and non-routine tasks. The main difference between the non-routine and routine task is that in the former the solver has to, at least partially, construct his/her solution method, while in the routine task, the method is already known by the solver or provided by an external source such as the book or the teacher (Lithner, 2012). To be able to determine if a task is routine or not, it is insufficient to consider properties of the task alone, but the relation between the task and the solver has to be considered (Schoenfeld, 1985).

In order to move from aforementioned “vicious circle”, where university calculus courses promote procedural knowledge and imitative reasoning, the non-routine tasks were implemented in a calculus course given to one group of civil engineering students at one university in Croatia. Selden et al. (1998) suggested that the non-routine tasks should be implemented as the explicit part of the curriculum in traditional calculus courses, not at the end, but throughout the course in the exercises sessions or in the homework. This group of civil engineering students obtained two or three non-routine tasks for homework in each exercise session. The homework should have been handed over to the teaching assistant of the course. The homework tasks were solved sometimes in the next exercise session, and sometimes the solution was only commented. The routine calculus tasks, which were given to the students in the course, asked for the application of some procedure that was shown to them either by lecturer or teaching assistant, while the non-routine tasks asked for more conceptual understanding. For instance, the routine tasks, that students solved in exercise session, asked for evaluation of function limit at some point e.g. “Find $\lim_{x \rightarrow 1} \frac{1-x^3}{1-x}$ ”, while the corresponding non-routine task given for a homework had the following form “Is there an a such that $\lim_{x \rightarrow 3} \frac{x^2+x-ax-a+4}{x^2-2x-3}$ exists? Explain your answer.”

Since Hiebert (2003) argues that students learn when they are given an opportunity to learn, we wanted to see if, and how, the non-routine tasks influenced on students’ reasoning.

METHODOLOGY

Participants

This study was conducted at one university in Croatia, and participants were the first year students who belonged to the civil engineering study program. The participants were chosen according to the scores obtained in the calculus mid-term exam. We have chosen students who scored between 65% and 70% in the exam, and we have classified them as average students, i.e. students who possessed some knowledge, were far from failing the exam, but also were not close to excellent scores. Their scores represent the most common results in the calculus exam among civil engineering students. In order to pass the calculus course, the students in this study program have to pass both written exam and oral exam. Moreover, the written exam consists of the mid-term exam and the final exam. In the written exam students have to solve various tasks, while the oral exam puts emphasis on the mathematical theory. Participating in the study was voluntary and students had right to withdraw from the study at any time, therefore we believe that students invested a significant effort into solving given tasks. The students in this study will be named only with the capital letters of their names in order to assure their privacy.

Method

The empirical data was collected from six task-based interviews. The students were interviewed in pairs. Arksey & Knight (1999) argue that this method is better for establishing an atmosphere of confidence with two students being interviewed at the same time and because the interviewees may ‘fill in gaps’ for each other. Also, students’ interaction may also be of interest. Schoenfeld (1985) gives support for this kind of interview, stating that two-person protocols often provide better insight and information about students’ reasoning and knowledge.

In order to estimate if there were any changes in students’ reasoning, students were interviewed in two occasions: in the middle of the course, just after the mid-term exam, and after passing the course. In the interview, the participants were given specific non-routine tasks designed in collaboration with lecturer and teaching assistant of the course. At the start of the interview, participants were given directions how to behave when solving given tasks. They were asked to talk to each other when solving the task, to state out loud everything they are thinking at the moment, not to plan what to say, and to behave like they are alone in the room working together on their homework or any other assignment. Similar directions were recommended by Ericsson & Simon (1993) in order to initiate the student’s thinking out loud.

In both occasions, the interview was separated into two parts. In the first minutes, the author only reminded the participants to keep talking if they were silent for a while. If the students struggled with the given tasks more

than several minutes, the author asked direct questions, trying to get the students to explain what they were doing and why they were doing it.

The interviews were video-taped, transcribed and analyzed together with the students' written work. We videotaped students work because we wanted to see their gestures, type of interaction between the students and their tone of voice. We believe this plays an important part in the student's behavior and can say something about the student's mathematical reasoning. However, in this paper we will focus more on the verbal expressions.

Tasks

Before the interviews took place, we examined participants' results and solutions in the mid-term exam and in the final exam where they had to solve several routine tasks from differential calculus. This was necessary to determine whether the students had the requisite calculus knowledge to solve the non-routine tasks.

The routine tasks in the mid-term asked students to:

- calculate the limit of the function at the point,
- examine whether or not the function is continuous at the point
- determine extreme values for the given function

The routine task in the final exam asked students to investigate all properties (domain, zero points, continuity, asymptotes, extremes, intervals of decrease and increase, the point of inflection, intervals of concavity) of certain function given with algebraic expression and to draw the graph of the function accordingly.

In the interview, students were given the non-routine task with concepts that emerged in the routine tasks in the exercise sessions and in the exams. However, there were no concrete algebraic expression for the functions in the tasks, wherefore those tasks asked for flexibility and creative reasoning.

Following tasks were given to students:

1. It is given function $f: R \rightarrow R$. Let $f'(x_0) = 0$ for only one point x_0 . Also let $x_0 > 0$ and $f(x_0) < 0$. If $\lim_{x \rightarrow +\infty} f(x) = \lim_{x \rightarrow -\infty} f(x) = +\infty$, how many zero points does function f have?
2. Sketch the graph of a function f which satisfies the following conditions:
 - a. f is discontinuous at $x = 0$ and $f(0) = 1$;
 - b. $f''(x) < 0$ for all $x < 0$ and $f''(x) > 0$ for all $x > 0$;
 - c. $f'(-1) = 0$ and $f'(x) \neq 0$ for $x \neq -1$.

The first task was given to students after the mid-term exam, and the second task was given after passing the course. Students were given sheets of papers for solving tasks. Also they could use their notebooks if they felt they should look something up.

RESULTS

Here we will not provide only students' answer to non-routine tasks, but we also will describe the whole process of solving to be able to observe students' reasoning.

Task 1

Firstly, we will report on Task 1, given in the middle of the course, and afterwards we will report on Task 2, given to students after passing the course.

Students D&P

Task 1 was given to students D&P when they were in the middle of the calculus course. When confronted with the task, students sat in a silence for a while and then student P gave his solution to the task where he identified $f'(x_0) = 0$ as zero point of the function and consequently concluded how this function had only one zero point. Furthermore, he placed this zero point in the origin of coordinate system.

P: It is equal with zero so... When we search for zero point of the function, it is in fact first derivative. Here it says $f'(x_0) = 0$, therefore it means that we have only one zero point. And it's 0. This point is in the origin of coordinate system.

Student D did not interfere while student P was explaining his solution; however, his face mimic implicated that he was not sure that this solution was right. Some time elapsed since students spoke, so interviewer started the second part of the interview. Here the interviewer asked students if they have ever met derivatives and where derivatives were used in the course. Student P interpreted $f'(x_0) = 0$ again as zero point of the function, and

even when interviewer explained that in fact x_0 represents critical point of the function, student P resumed with reasoning in wrong way. However, student D claimed that x_0 was point of inflection:

I (interviewer): Have you ever used a first derivative? What for?

P: Yes, we have. It's point in which graph of the function crosses x -axis.

I: Hm... What if I say it's, in fact, a critical point. What would that be?

P: Zero point.

I: Hm... Have you ever used another derivative?

P: Yes, second. When something is maximum or minimum.

D: I think $f'(x_0) = 0$ says x_0 is point of inflection.

[silence]

Even with significant guidance from the interviewer, students D&P could not move in the reasoning sequence. They claimed the task was too difficult pointing out the fact they had never met task phrased this way, and that task was created for mathematics students. Although students had experienced tasks without calculation, they eventually gave up, not examining other given conditions and claiming there are no concrete numbers to work with.

I: Hm... Let's try this way... Where is this point? What else is given?

D: It's in the origin.

I: Do you have some other information?

P: I do not understand. I have never met task like this.

D: It's too difficult. I know to calculate zero point for the function but this way no... We are not mathematics students.

I: But you met tasks without calculation in the course, didn't you?

P: Yes.

Students N&M

Students N&M solved task without any assistance or prompts from the interviewer. They had read the task silently and afterwards they commented the amount of the written text in the tasks. Their whole reasoning process lasted very shortly, but they also experienced some difficulties in the process: the student N identified x_0 as the zero point, and the student M situated the point in the wrong part of the coordinate system, namely the first quadrant:

N: Too much text [laughs].

M: Hm, well...

N: How many zero points does function f have?

M: So for only one x we have $f'(x_0) = 0$... Aha, it means that function has only one extreme.

N: Zero point.

M: Zero point and extreme are not the same.

N: Oh, yes yes... It's about extreme values.

M: This extreme value is here [shows first quadrant]....

N: No... x_0 is here [point at positive part of the x axis]... and $f(x_0)$ is negative.... so the point is in fourth quadrant.

Students got the idea to separate function limit in two parts and to see what each part represents. Student M said that function values go to the positive infinity for all positive x -values, and students N concluded the same for negative x -values. They made the figure of the given function in their head and this enabled them to give answer to the posed question. Interestingly, when the reasoning went in the wrong direction, the students helped each other; one member of the pair steered the reasoning process on the right track.

Students B&J

The student B had read Task 1 out loud, and both students had the same reaction to the given task, namely they were intimidated with the amount of data in the task. When students began to interpret the given data, student B concluded that $f'(x_0) = 0$ is a derivative of the constant, but student J corrected him.

J: This is weird... Never seen something like this... this information... too much data.

B: Yes. I agree... Much data... It [tasks] says that derivative of the constant is zero.

J: No, that's critical point.

B: Hm...

[silence]

The interviewer asked students to express out loud what they were thinking that moment, but the students stayed silent for several minutes. In order to stimulate the reasoning process, the interviewer gave students a prompt:

I (interviewer): Go on... What seems to be the problem?

B: Do not know what to do with the data.

I: What about drawing what is given in the task?

Even with this prompt, students were not able to move further in the reasoning sequence, and the task was solved with a significant guidance from the interviewer. The interviewer asked what the given data represented and the students responded accordingly. The students B&J alternated in data interpretation, but none of them was independent in the reasoning process. The point $(x_0, f(x_0))$ was drawn in the correct quadrant, and students concluded that the function values go to infinity:

I: Where does the point $(x_0, f(x_0))$ lie?

B: In the second quadrant [pointing at the fourth quadrant] because x_0 is positive and that is on the right from the origin on x -axis, and $f(x_0)$ is negative and that is down on y -axis.

I: What about next piece of data? What does it says?

B: That everything goes to infinity.

At the end of the task, student B concluded that he can sketch parabola from the given data but he was uncertain how to draw it because there is only one point given in the task. However, student J took initiative and made drawing.

B: Hmm... this is kind of parabola... (laughs). But where to put it? I have only one point at disposition.

J: [takes pencil and draws] You do not need another point. See? If you connect all conditions, you get graph.

B: Oh... and there are two zero points

Task 2

Here we will present detail of students' solution for Task 2. This task was given to students shortly after they passed the calculus course. Here we will also provide detailed descriptions of students' reasoning and excerpts.

Students D&P

Initial behavior of students D&P was similar as in Task 1, but this time student D was involved in solving from the start. Student P stated that function crosses over x -axis when the function has discontinuity in zero, and student D stated that second derivative is usually used for calculating minimum and maximum of some function.

P: [draws coordinate system] This means that function in 0 would cross axis. [draws small circle in the origin of coordinate system]

D: Second condition... We used this when we calculated minimum and maximum.

[silence]

Students stopped after interpretation of two conditions. It seemed that they did not know what to do next, so after several minutes of silence, the interviewer asked them to explain the role of the first and second derivative when examining properties of the function. The students remained silent, so the interviewer tried another approach asking them how they determined intervals of concavity for some function. It was only after this prompt that students connected concavity and second derivative. Later student P interpreted -1 as the zero point of the function in third condition $f'(-1) = 0$, but student D corrected him. However, the students could not incorporate all conditions to sketch the figure.

I (interviewer): How did you determine where the function is concave upward or concave downward?

P: It's concave upward when second derivative is less than zero.

D: Hm...no... I think is concave downward in that case.

P: [draws graph of function where certain parts are concave upward and concave downward] So let's look at parabola... second derivative... greater than zero here where [it] is concave upward, and concave downward here [pointing to the figure]

[silence]

I: What about next condition? What does -1 represent?

P: It's zero point.

D: Hmm... no it's maximum. See here at the figure [pointing to upper figure]... the derivative is zero in the critical point and then it follows it's maximum form other given conditions

[silence]

I: And now, can you incorporate all condition in your sketch?

P: I cannot make figure in my head.

Students N&M

After several months, when faced with Task 2, students N&M employed the same strategy as they had in Task 1. They read the task silently and then they started to interpret conditions like they are talking to each other. First of all, student N decided to draw the coordinate system. Then student M said that the function f had a hole in 0 and student N sketched that hole in the coordinate system as an empty circle at the point (0,0) and drew a full black circle at the point (0,1). Then they interpreted condition b . Student M concluded that condition b described when the function was convergent or divergent, and student N concluded that function increased or decreased at given intervals. On the other side of the paper, student M drew his sketch of divergent and convergent functions. In fact, those figures represented curves being concave upward and concave downward. Student N pointed out that discontinuity should be incorporated in the drawing, and it should be where the function was changing its shape from concave downward to concave upward. But, this remark had disturbed the reasoning sequence of student M. He became puzzled with the outcome, but student N took over and drew that part of figure.

M: Second condition... It could be ... [silence]

I (interviewer): Where have you used second derivative?

M: When something is convergent and divergent...but I do not remember when you use the first thing and when the second

N: For intervals of decrease or increase.

M: That is the first derivative, the second is used for that when something converges or diverges [draws a figure of curves being concave upward and concave downward]

N: Ok, you mean concave upward and downward...Discontinuity is here where the function changes its shape.

M: Well, no... that would mean... when $f''(x) > 0$, it is concave upward, when $f''(x) < 0$, it is concave downward.

N: See, here where $y = 1$, it fits... it goes like this [corrects figure, draws curve looking like parabola, having minimum]

The students M&N switched to condition c . identifying -1 as the only extreme value of this function. They changed their figure according to a new condition, and again the student M was a bit puzzled if new figure was correct solution of the task. The student N explained that new figure fulfills all conditions, but the student M expressed his doubts once more because that graph did not look alike any other graph he had ever seen:

M: But we have two functions now...

N: We fulfilled all conditions. It's alright.

M: So it's ok that we have two parts?

N: The function has discontinuity in 0.

M: Hm...I tried to imagine something I have seen before, and now I see it doesn't make sense.

Students B&J

In Task 2, the students B&J decided to draw the coordinate system firstly, and then they read the rest of the task. Reading out loud the condition a ., the student B noticed there are some points in the text and drew them in the coordinate system. The points, he marked, had following coordinates (1,0) and (0,0). He said that condition b was about intervals of increase and decrease of that function, and then he stopped looking puzzled. During that time, student J was silent, examining the task. Since both students did not say a word for longer time, the interviewer got involved asking questions about given condition. Those questions served as an aid in the reasoning sequence. The student B corrected his drawing by marking point (0,1) instead of point (1,0), but he interpreted condition b . again in the same manner. This time student J got involved and corrected him.

I (interviewer): Are you sure you drew it correctly?

B: Well...no [corrects his drawing]

I: What about condition b ?

B: We had this at maximum and minimum. When f'' is less than zero, then we have maximum. When f'' is greater than zero we have minimum.

J: No. This [condition] says when the function is concave upward and when the function is concave downward...

[silence]

I: Where the function is concave upward and where the function is concave downward?

J: On the left side of x -axis is concave upward and on the right side is concave downward.

[silence]

Students B&J discussed how shapes of concave upward and concave downward looked like, trying to decide what shape parabola $y = x^2$ has. After discussion, the student J drew the graph of function that satisfied condition b . Students moved to condition c . However, this new information caused confusion when students tried to incorporate it with other data they had. The aid of interviewer was needed again in the form of leading questions. At the end of the task, the students did not adjust their figure so that all conditions were met. Moreover, drawing represented the graph of the function with two extrema; having maximum on the left side of x -axis, and having minimum on the right side of x -axis. In this part of interview, students J had took the lead role.

I: What does the third condition says?

J: That's critical point.

I: Where?

J: On the negative part of the x -axis.

I: What property does function have there?

J: It's concave upward

I: So what kind of point we have there.

J: Hm ... It's maximum. [puts the pencil down]

I: Is this solution?

B: Yes.

DISCUSSION

These non-routine tasks do not represent problems in terms of Schoenfeld (1985), but can be characterized as the moderately non-routine tasks. The interviews given in two occasions highlighted some difficulties, which students can encounter when solving such non-routine tasks. Also, we were able to detect if there were changes in the students' reasoning as they progressed through the course.

Students D&P experienced significant difficulties in the process of reasoning in both occasions. The absences of computation in the given tasks prevented students to rely on procedures and to use algorithmic reasoning to which they were more accustomed. Their reasoning in Task 1 had erroneous base from the start what disabled them to move further from the first condition. In the beginning, student P used familiar AR when he concluded that the function in fact has one zero point. Here he relied on superficial property, namely the expression where the function f was equal with the zero. Student D also used imitative reasoning when he concluded that x_0 is the point of inflection. He relied on recalling something he has seen before, not giving any arguments why he reached such conclusion. The students experienced significant frustration because they could not interpret the given condition in the right way and this reflected on their reluctance to examine other conditions. They pointed out that they knew how to calculate derivatives, but that the tasks without any calculations were only for mathematics students. Certain difficulties appeared also in Task 2, where students, only after the intervention, could move on further in the task. The students showed they were quite dependent on the external guidance in their reasoning. But, if we compare students' reasoning examined in two occasions, in the middle of the course (Task 1), and the other after the course (Task 2), we can see some positive shifts in the sequence of reasoning. Reasoning in the second task is in some part local creative since students did use argumentation and considered intrinsic properties of problematic components all together.

We identified some negative met-befores and met-afters in the base of their knowledge structure, which hindered their reasoning sequence. For example, student P interpreted $f'(x_0) = 0$ or $f'(-1) = 0$ as x_0 or -1 were the zero point of the function, and that had a stopping effect in his further reasoning. Calculation of zero points of some function is frequently done in high school mathematics, wherefore student P disregarded a sign for the derivative and identified this expression with commonly seen expression $f(x_0) = 0$ and this triggered

familiar AR. On the other hand, in this calculus course, students learn about the concepts of critical points and extrema before the concept of point of inflection. Therefore identifying the expression $f'(x_0) = 0$ in Task 1 as a property which satisfies the point of inflection can be considered as the met-after which, we believe, influenced on student D's reasoning.

Students M&N solved given tasks themselves with almost no assistance from the interviewer in both occasions. They complemented their reasoning in both tasks and together reached conclusions that were anchored in relevant mathematical properties of the concepts they were reasoning about. In Task 1, student positioned given point in the right quadrant and concluded it was a critical point from the relations that were provided. They reached meaningful conclusion about function values after separating the function limit in two parts and they verified their solution at the end of the task. In Task 2, they interpreted all conditions in the right way, and sketched required graph of the function. But, in Task 2, it became more evident that student M aspired toward something he had seen before, showing the desire toward familiar AR. Even though students relied on conceptual understanding, the puzzlement of student M at the end of the task exposed his uncertainty. The obtained graph did not resemble any graph he had seen before and he believed this was not the right solution.

We identified certain negative met-befores in their knowledge structure. In Task 1, those were interpretation of x_0 as zero point in $f'(x_0) = 0$ (student N), and placing the point $(x_0, f(x_0))$ in the first quadrant (student M). The first is similar as in the case of students D&P, and the latter can be connected with presentation of many function graphs in the textbooks and lectures. Usually, when the lecturer (either at university or secondary school) sketches graph of arbitrary function as an example to show some property, it is mainly placed in the first quadrant, or the major part of the graph is sketched there. In Task 2, student N identified the second derivative with properties of increase or decrease of the function. In this calculus course, usage of first derivative for intervals of increase and decrease is taught before the second derivative and its connection with concavity. This met-before indicates that concepts related to the first and second derivatives were not properly understood. But, it seems that this mental construct did not have negative effect on solving the tasks in calculus exams, because student did pass the course. Even though these met-befores were evident in students' knowledge, their reasoning was not suppressed like in the case of students D&P. The members of the pair corrected each other, and consequently, produced a valid solution for the tasks. The question that remains unanswered is whether students alone would be able to solve the tasks, and whether these negative met-befores would stop them to proceed further in the reasoning process.

Reasoning of students B&J was guided with the assistance of the interviewer in both occasions (in the middle of the course and after the course). Moreover, in Task 1, students showed inability to move further beyond their inference about the amount of the text and data in the task. Besides giving a prompt for drawing data in the coordinate system, the interviewer asked what the certain piece of data represents, but did not participate in the interpretation. Therefore components of the local creative reasoning can be found in students' reasoning sequence. Using their conceptual understanding, students obtained the right solution, but the final conclusion could not be reached without interviewer's initial help. In Task 2, students showed more initiative, namely they were more creative, but the interviewer again served as the support and the guidance in the reasoning sequence. The students were reluctant to express their thinking out loud and to continue their reasoning, what can be inferred from silence gaps in the process. However, we would not say that students lacked resources or knowledge for the tasks. Students used arguments that are mathematically founded to provide validity of their conclusions. Their reasoning was anchored in intrinsic properties of the components in the reasoning: the relation between the property of function being concave upward or downward and the shape of parabola to determine what shape given function has, or the relation between critical point and the shape of the function to conclude what extreme value is given.

Some negative met-befores were found in knowledge structure of student B. At the end of the Task 1, student B identified graph of the function as the graph of well-known quadratic function. This interpretation of the obtained graph does not have to be necessarily problematic met-before, but it certainly can have negative impact in other situations. Here we see another met-before as much more problematic and that is a need for "formula" i.e. concrete expression which should help the student to draw "parabola". According to Tall (2006), seeking for a function that person has already met and the need for formula hinders the development of advanced mathematical thinking. Another negative met-before is the interpretation of condition $b.$, namely connecting $f'' < 0$ with the property of increase or decrease of some function, what together with the interpretation of $f'(x_0) = 0$ as the derivative of the constant, indicates that student did not quite understand the topic of first derivative and related concepts of: extrema and intervals of increase and decrease. However, the student did pass the calculus course with the average grade, what indicates that these problematic met-befores were not visible in reasoning that was required in the calculus exams.

CONCLUSION

The students in this study frequently used imitative reasoning during their schooling in primary and secondary education. The aim of the study was to examine if meeting the non-routine tasks in the calculus course had any effect on their reasoning. The results of the study showed that creative reasoning was developing slowly. When solving the non-routine tasks, students showed tendency to be guided in the reasoning sequence even at the end of the course, or more likely, after passing the course. Also, they expressed the need for concrete expressions to work with. On the other hand, what students had met before and after learning some mathematical topic had a wide impact on their reasoning. Negative met-befores and met-afters stopped students in further task solving, or turned them to imitative reasoning. However, our intention is not to classify all met-befores and met-afters that can appear in students' knowledge and that can inhibit creative reasoning, but to caution to their existence. The students in our study passed the calculus course, what indicates that those met-befores and met-afters did not prevent them to successfully solve tasks that asked for imitative reasoning. We based our conclusion also on students' mid-term and final exams that we have examined before each interview session.

When faced with new situations, students tend to look for something familiar, and usually seek for a remedy in the form of imitative reasoning, like searching the textbook for similar solutions or going through their recollection of similar tasks (e.g. Boesen et al., 2010, Haavold, 2012). Selden et al. (1998) pointed out that students lack tentative solution starts, i.e. general ideas for beginning the process of finding a solution, and that, together with mental constructs of met-befores and met-afters, provides significant obstacle for creative reasoning. We argue that mathematics educators and lecturers should take this into consideration when teaching students. On the other hand, creative reasoning is beneficial to investigate students' understanding and to check the quality of their long-term knowledge. In imitative reasoning, students do not consider intrinsic properties of the objects they are reasoning about, and frequently they rely on well-established procedure, mimicking, almost unconsciously, its every step (Lithner, 2012). Even though imitative reasoning provides reduction of complexity in the course requirements, students do not construct appropriate meaning in such process. The remedy is not avoidance of non-routine tasks, but quite opposite, facing students with new situations. The non-routine tasks and creative reasoning can uncover negative met-befores and met-afters which students are oblivious to when they perform imitative reasoning. This uncovering is important for the sequencing courses that build upon previous courses, i.e. where new knowledge is building up previous acquired and mastered concepts.

But is it possible that the non-routine tasks become more visible in the course, not only as the part of the homework, but also as the part of exercise sessions? And to whom does this matter? Giving answers to these questions is not simple. In the calculus course that our participants took, the non-routine tasks were implemented mainly in the homework part. The course syllabus is overloaded, and it is difficult to explicitly deal with non-routine task on regular basis. During the course, students showed the resistance toward non-routine tasks that demanded more of their invested time than usual routine tasks. But we as educators argue that it does matter, because we want to build up working force that can adapt to any requirements business and economy demand today. We believe that flexible thinking and creative reasoning are part of this ability. Looking from the students' position, this question does not have unique answer. Students, not only in this study program, but in many other science and technical study programs, have many requirements in the courses more related to their profession. They usually lack time for deeper engagement in mathematics, but at the same time they want to pass the mathematics course and would like to know how to apply gained mathematical knowledge (Jukić Matić, 2013). There is no simple solution to this problem and these facts put us in very difficult position. We conclude this paper with a note that the non-routine tasks, besides being part of the homework, became the part of the oral exam in this study program.

REFERENCES

- Arksey, H., & Knight, P. (1999). *Interviewing for social scientists*. London: Sage.
- Bergqvist, E. (2007). Types of reasoning required in university exams in mathematics. *Journal of Mathematical Behavior*, 26(4) 348-370.
- Bergqvist, E. (2012). University mathematics teachers' views on the required reasoning in calculus exams. *The Montana Mathematics Enthusiast*, 9(3), 371-408
- Boesen, J., Lithner, J., & Palm T. (2010). The relation between types of assessment tasks and the mathematical reasoning students use. *Educational Studies in Mathematics*, 75 (1), 89-105
- Chinnappan M., Dinham S., Herrington A., & Scott, D. (2007). Year 12 students and Higher Mathematics: Emerging issues, *AARE 2007 International education research conference*

- Cox, W. (1994). Strategic learning in a-level mathematics? *Teaching Mathematics and its Applications*, 13, 11–21.
- Ericsson, K., & Simon, H. (1993). *Protocol analysis: Verbal reports as data*. Cambridge: MIT Press.
- Haavold, P. (2010). What characterizes high achieving students' mathematical reasoning? In *The elements of creativity and giftedness in mathematics*. Sense Publisher
- Hiebert, J. (2003). What research says about the NCTM standards. In Kilpatrick, J., Martin, G., & Schifter, D. (eds) *A Research Companion to Principles and Standards for School Mathematics*, pp 5-26. Reston Va., National Council of Teachers of Mathematics.
- Jukić Matić, Lj. (2013). Non-mathematics students' knowledge and their beliefs about mathematics (under review)
- Lima R.N. de, & Tall D. (2008). Procedural embodiment and magic in linear equations. *Educational Studies in Mathematics*, 67(1), 3-18.
- Lithner, J. (2003). Students' mathematical reasoning in university textbook exercises. *Educational Studies in Mathematics*, 52, 29–55.
- Lithner, J. (2004). Mathematical reasoning in calculus textbook exercises. *Journal of Mathematical Behavior*, 23, 405–427.
- Lithner, J. (2008). A research framework for creative and imitative reasoning. *Educational Studies in Mathematics* 67(3).
- Lithner, J. (2012). University mathematics students' learning difficulties, *Education Inquiry*, 2(2), 289-303
- McGowen, M., & Tall, D. (2010). Metaphor or Met-before? The effects of previous experience on the practice and theory of learning mathematics. *Journal of Mathematical Behavior*, 29, 169--179.
- McNeal, B. (1995). Learning not to think in a textbook-based mathematics class. *Journal of Mathematical Behavior* 14 18–32.
- Niss, M. A. (2003). Quantitative literacy and mathematical competencies. In B. L. Madison, & L. A. Steen (Eds.), *Quantitative literacy: why numeracy matters for schools and colleges*. (pp. 215-220). Princeton: National Council on Education and the Disciplines.
- Schoenfeld, A H. (1991). On mathematics as sense-making: An informal attack on the unfortunate divorce of formal and informal mathematics. In J. Voss, D. Perkins, and J. Segal, editors, *Informal Reasoning and Education*, pages 311–344. Hillsdale, NJ: Lawrence Erlbaum Associates
- Schoenfeld, A. (1985). *Mathematical problem solving*. Orlando, FL: Academic Press.
- Selden, J., Mason, A., & Selden, A. (1998). Can Average Calculus Students Solve Nonroutine Problems? *Journal of Mathematical Behavior*, 8, 45-50.
- Tall, D. (1997). Functions and Calculus. In A. J. Bishop et al (Eds.), *International Handbook of Mathematics Education*, 289–325, Dordrecht: Kluwer.
- Tall, D. (2006). A Theory of Mathematical Growth through Embodiment, Symbolism and Proof, *Annales de Didactique et de Sciences Cognitives*, IREM de Strasbourg, 11, pp. 195-215.

5. SINIF “VÜCUDUMUZ BİLMECESİNİ ÇÖZELİM” ÜNİTESİ BAŞARI TESTİ: GEÇERLİK VE GÜVENİRLİK

5th CLASS “OUR BODY: LET’S SOLVE THE PUZZLE” UNIT ACHIEVEMENT TEST: VALIDITY AND RELIABILITY

Büşra BAKİOĞLU
Tokat Kızılköy Ata Yavalar Ortaokulu ve Amasya Üniv. Fen Bil. Ens. Doktora Öğrencisi
busra.durmus86@hotmail.com

Doç. Dr. Sevilay KARAMUSTAFAOĞLU
Amasya Üniversitesi, Eğitim Fakültesi, İlköğretim Bölümü
sevilayt2000@yahoo.com

Doç. Dr. Orhan KARAMUSTAFAOĞLU
Amasya Üniversitesi, Eğitim Fakültesi, İlköğretim Bölümü
orseka@yahoo.com

ÖZET: Bu çalışmada, 5.sınıf fen bilimleri dersi “Vücudumuz Bilmecesini Çözelim” isimli ilk ünitesine ilişkin öğrencilerin başarılarını belirlemede etkili olabilecek geçerli ve güvenilir bir başarı testi geliştirilmesi amaçlanmıştır. Çalışma grubunu 2013-2014 eğitim-öğretim yılında 5. sınıflarda öğrenim gören 76 öğrenci oluşturmaktadır. Testin geliştirilmesi sürecinde öncelikle öğretim programı dikkate alınarak bir kazanım listesi hazırlanmış, kapsam geçerliliği için belirtke tablosu oluşturulmuş ve bu kazanımlara uygun sorular seçilmiş, üç uzman ile altı öğrencinin görüşleri alınarak testin uygulama süresi ve anlaşılmasında zorluk çekilen kısımlar tespit edilerek gerekli düzeltmeler yapılmıştır. Daha sonra Vücudumuz Bilmecesini Çözelim Ünitesi Başarı Testi (VüBiÇöt) çalışma grubuna uygulanmıştır. Analizler sonucunda testin, ortanca 21, ortalaması 19.72, modu 26, ortalama güçlüğü 19.33, standart sapması 5.99 ve KR-21 güvenilirliği ise 0.839 olarak hesaplanmıştır. Bu doğrultuda geliştirilen VüBiÇöt’ün öğretmen, öğrenci ve araştırmacılar tarafından kullanılabilirlik geçerli ve güvenilir bir test olduğu sonucuna varılmıştır. Çalışma sonunda ilgililere uygulanabilirliği ve geliştirme sürecine ilişkin öneriler sunulmuştur.

Anahtar Kelimeler: vücudumuz bilmecesini çözelim, test geliştirme, başarı testi.

ABSTRACT: In this study it is aimed to develop an available and reliable achievement test that is able to be effective to define the success of students related to the first unit Science of 5th grades named “Our Body: Let’s Solve the Puzzle” 76 students, studying in 5th grade during 2013-2014 academic year generating the workgroup. In the process of developing test; considering curriculum, an acquisition list was prepared, for content validity a table of specifications was made and questions suitable for these acquisitions were chosen, duration of test application and some parts of the test that were difficult to understand were determined and necessary corrections were made with the received options of three specialist and six students. Thereafter, the achievement test of the unit “Our Body:Let’s solve the puzzle” (VüBiÇöt) was carried out to workgroup. In the consequence of analyses; median 21, mean 19.72, mode 26, average difficulty 19.33, standart deviation 5.99 and KR-21 reliability was calculated as 0.839. Accordingly, it was concluded that (VüBiÇöt) was a valid and reliable test that can be used by students, teachers and researchers. At the end of the study, suggestions were presented about practicability and development process for those concerned.

Key Words: our body:let’s solve the puzzle, test development, achievement test.

GİRİŞ

Sınavlar, eğitim sistemimizin ayrılmaz ve önemli bir parçasıdır (İpek Akbulut & Çepni, 2013). Dünyanın birçok yerinde ve ülkemizde eğitim sisteminin kontrolü ölçme ve değerlendirme yardımı ile yapılabilmektedir. Eğitim kurumlarında ölçme ve değerlendirme yapmanın birçok nedeni vardır. Eğitimde ölçme ve değerlendirme yapmanın ana nedeni, “hedeflerin gerçekleşme düzeyi nedir?” sorusuna cevap aramaktır (Özhan & Odabaş, 2009). McDonald (2002), öğretmenlerin ölçme yaparken doğru aracı seçmelerinin eğitimde doğru kararlar almak için önemini vurgulamıştır. Eğitimde kullanılan ölçme araçları bilişsel alan, duyuşsal alan ve devinişsel alana göre farklılık gösterir. Bilişsel alan ölçme araçları; yazılı sınavlar, kısa cevaplı testler, doğru yanlış tarzı

sorular, çoktan seçmeli testler, eşleştirmeli testler, sözlü sınavlar, ödev ve projeler; duyuşsal alan ölçme araçları; ilgi ölçekleri ve tutum ölçekleri; devinişsel alan ölçme araçları; iş-performans testleri, rubrikler, derecelendirme ölçeđi ve kontrol listeleridir (Özhan ve Odabaş, 2009). Günümüzde en yaygın kullanılan ölçme aracı çoktan seçmeli testlerden oluşan araçlardır (FEM, 2011). Bunun nedeni, çoktan seçmeli testler nesnel olması ve aynı zamanda kolay puanlanmasıdır (Bağcan Büyükturan & Çıkrıkçı Demirtaşlı, 2013). Milli Eğitim Bakanlığı, 2013-2014 öğretim yılından itibaren fen bilimleri dersi öğretim programında araştırma-sorgulamaya dayalı öğrenme yaklaşımı temel alınarak hazırlanan yeni müfredat programını uygulamaya geçirmiştir. Bu program, 2004 yılındaki öğretim programının revize edilmiş şeklidir. Araştırma-sorgulamaya dayalı öğrenme sürecinde; genel olarak öğrencilerin öğrenmesinden kendilerinin sorumlu olduğu, öğrenme sürecine öğrencinin aktif katıldığı, öğrencinin bilgiyi kendi zihinlerinde yapılandırmaya olanak tanıdığı bir strateji benimsenmiştir (MEB, 2013). Bu yeni programın ölçme-değerlendirme anlayışına göre, öğrenciler öğrenme süreci içerisinde izlenmeli ve yönlendirilmelidir. Öğrenme sırasında oluşabilecek güçlükler belirlenerek giderilmeli, anlamlı ve kalıcı öğrenmeyi tam olarak sağlamak için öğrencilere geri bildirim yapılmalıdır. Bu nedenlerden dolayı biçimlendirici (formative) değerlendirme biçimi bu programa göre ön plana çıkmaktadır. Formal eğitim kurumlarında biçimlendirici değerlendirmeler ünite sonu değerlendirmeleri, dönem içi sınavları şeklindedir. Ünite sonu değerlendirmeleri için her üniteye uygun geçerli ve güvenilir başarı testlerinin geliştirilmesinin ölçme ve değerlendirmeyi objektif kılacağı düşünülmektedir. İlgili alan yazınına baktığımızda ülkemizde pek çok başarı testi geliştirme çalışmalarının olduğu görülmüştür (Uzunöz & Buldan, 2012; Şen & Eryılmaz, 2011; Börekci, 2010; Çoşkun, 2010; Bağcan Büyükturan & Çıkrıkçı Demirtaşlı, 2013; Güngör & Özgür, 2009; Gül & Yeşilyurt, 2011, Yurdabakan & Olgun, 2011). 5.sınıf Vücudumuz Bilmecesini Çözelim Ünitesine dair ülkemizde geliştirilmiş ölçüm araçları incelendiğinde sadece bir tane çalışma ile karşılaşmıştır (Güngör & Özgür, 2009). Bu ölçüm araçları başlı başına ölçme aracı geliştirmek için değil de, diğer değişkenlerle korelasyona bakılmak için geliştirilmiş ve kullanılmıştır.

Yapılan bu çalışma ile 5.sınıf Vücudumuz Bilmecesini Çözelim Ünitesi'ne yönelik bir başarı testi geliştirilerek ilgili alan yazınındaki eksikliğin giderileceđi, fen bilimleri öğretmenlerine biçimlendirici ve tanılayıcı değerlendirme yapımları için yardımcı olunacağı ve 5.sınıf öğrencilerine ünite ile ilgili soru kaynađı olacağı düşünülmektedir. Yapılan bu çalışmada 2013 yılında revize edilen fen bilimleri dersi öğretim programının, 5.sınıf Vücudumuz Bilmecesini Çözelim Ünitesi kazanımlarına uygun olarak sorular içeren geçerli ve güvenilir bir ölçüm aracı geliştirilmesi amaçlanmıştır.

YÖNTEM

Evren ve Örneklem

Araştırmada 5.sınıf Vücudumuz Bilmecesini Çözelim Ünitesine dair bir başarı testi geliştirilip geçerlik ve güvenilirlik incelemeleri yapılması için üniteye ait kazanımlar 2013 fen bilimleri öğretim programına paralel olarak hazırlanmıştır. Bu kazanımlara uygun sorular araştırmacı tarafından bizzat hazırlanmıştır. Test son şeklini almadan önce uzman görüşleri alınmış, altı ortaokul 5.sınıf öğrencisine pilot uygulama için hazırlanan sorular çözdürülmüştür. Öneriler doğrultusunda teste son şekli verilip 76 ortaokul 5.sınıf öğrencisine uygulanmış ve veri analizleri tamamlanmıştır. Çalışmadaki örneklem, kolaylık örnekleme (convenient sampling) yoluyla seçilmiştir. 2013-2014 eğitim-öğretim yılının birinci döneminde Tokat ili merkezindeki 5 ortaokuldan seçilen toplam 76, 5.sınıf öğrencisi bu çalışmanın örneklemini oluşturmaktadır.

VüBiÇöt'nin Geliştirilme Süreci

5. sınıf Vücudumuz Bilmecesini Çözelim Ünitesi Başarı Testi (VüBiÇöt) araştırmacı tarafından öğrencilerin bu ünitedeki başarılarını değerlendirmek amacı ile geliştirilmiştir. Bu ünite 5.sınıf fen bilimleri dersinde 13 kazanımdan oluşmaktadır. VüBiÇöt, 30 tane çoktan seçmeli, dört seçenekli sorulardan oluşan bir testtir. Soruların hepsi çoktan seçmeli olarak hazırlanmıştır. Bunun nedeni; çoktan seçmeli soruların diğer soru tiplerine göre daha kolay ve hızlı bir şekilde uygulanabilir olması ve bu tip soruların araştırmacının, sonuçları daha nesnel bir şekilde değerlendirmesine yardımcı olmasıdır (Gronlund & Linn, 1990; Akt: Şen & Eryılmaz, 2011).

VüBiÇöt geliştirilmeden önce 2013 fen bilimleri dersi öğretim programında olan Vücudumuz Bilmecesini Çözelim Ünitesine ait bütün üniteyi kapsayan 13 maddelik bir kazanım listesi hazırlandı. Daha sonra araştırmacı tarafından fen bilimleri öğretim programına konulması gerektiđi düşünülen 7 kazanım da bu kazanımlara eklenerek toplam 20 kazanım oluşturuldu. Kazanım listesi bir fen eğitimi uzmanı tarafından iki kez revize edildi. Bu 20 kazanımın toplam 36 soru ile ölçülmesi planlandı. Daha sonra ilgili kazanımlarla örtüşen maddeler araştırmacının kendisi tarafından titizlikle yazıldı. Sadece sorulardaki şekiller www.fenokulu.net internet adresinden alınmıştır. Daha sonra, kazanımların ve ilgili soruların 5.sınıf Vücudumuz Bilmecesini Çözelim Ünitesini tam olarak kapsadığından emin olmak için bir belirtke tablosu oluşturuldu. Bu tablo aynı zamanda

testin içerik geçerliği için de bir kanıt oluşturmaktadır. Hazırlanan belirtke tablosundaki sorular ve kazanımlar Bloom Taksonomisi'nin bilişsel alanına göre hazırlandı. Duyuşsal ve psikomotor (devinişsel) öğrenme alanları test tekniği ile ölçülemeyeceğinden, bu alanlara yönelik sorular, öğrencilerin sahip olması gereken alt bilgilerini ölçecek tarzda yazılmıştır. Bu doğrultuda sorular test belirtke tablosu da göz önünde bulundurularak bir fen bilimleri öğretmeni tarafından son kez gözden geçirildi. Testin kapsam geçerliğini sağlamak için üniversitelerin İlköğretim Fen Bilgisi Eğitimi alanında görevli öğretim üyesi ve iki fen bilimleri öğretmeni tarafından içerik ve format yönünden, iki Türk Dili uzmanı tarafından da yazım kuralları ve dil bilgisi açısından incelenmiştir. Uzmanların değerlendirmeleri ışığında testte gerekli düzeltmeler yapılmıştır. Bu işlemler sonucunda uzmanlar, geliştirilen başarı testinin bütün üniteyi temsil ettiğini, dil açısından öğrencilerin seviyesine uygun olduğunu, yazı ve şekillerin 5.sınıf öğrencilerinin seviyesine uygun olduğunu ve bir ders saati içinde testin uygulanabileceğini belirtmişlerdir. Testin ilk halinde, test 36 sorudan oluşmaktadır. Soruların tümü çoktan seçmeli soru olarak yazılmıştır. Bazı sorular kazanımlarda olmasına rağmen yapılan analizlerde madde ayırt ediciliği düşük çıkmasından dolayı testin ikinci halinden çıkarılmıştır. Her bir kazanımın en azından bir soru ile ölçülmesi ve Vücutumuz Bilmecesini Çözelim Ünitesinin tüm konularının teste temsil edilmesi zorunlulukları göz önünde bulundurularak testin ikinci hali için toplam soru sayısı 30 olarak belirlenmiştir.

BULGULAR

Geliştirilen VüBiÇöt, Vücutumuz Bilmecesini Çözelim Ünitesi işlendikten sonra pilot çalışma olması açısından 6 öğrenciye uygulanmıştır. Pilot çalışmada öğrencilerin 1 ders saati (40 dakika) içerisinde soruları çözebildikleri gözlemlenmiştir. Öğrencilerin kelimeleri, cümleleri, şekilleri vb. anlayıp anlamadıklarına bakılmış, testin zorluğu hakkında düşünceleri alınmıştır. Öğrenciler testin dilinin anlaşılır olduğunu ve 1 ders saati içinde çözebildiklerini belirtmişlerdir. Pilot çalışmanın ardından Vücutumuz Bilmecesini Çözelim Ünitesini tamamlayan, 5 ayrı okulda öğrenim gören toplam 76 öğrenciye VüBiÇöt uygulanarak veriler toplanmıştır. Daha sonra her bir soru için madde ayırt edicilik ve madde güçlük indeksleri hesaplanmıştır. Madde ayırt edicilik indeksleri 0.40'dan büyükse madde çok iyi, 0.30-0.39 arasında ise oldukça iyi, 0.20-0.29 arasında ise düzeltilmeli ve 0.20'den küçükse madde testten çıkarılmalıdır (Büyüköztürk ve diğerleri, 2010). 6 adet sorunun madde ayırt edicilikleri zayıf bulunmuştur. Bu sorular testten çıkarılmıştır. Bu soruların kapsadığı kazanımları ölçen başka sorular da olduğu için, bu soruların testten çıkarılması, testin kapsam geçerliğini etkilememiştir. Bu maddelerin ayırt edicilik ve madde güçlükleri Tablo 1. de verilmiştir.

Tablo 1. Testten Çıkarılan Maddelerin Madde Ayırt Edicilik ve Güçlük İndeksleri

Soru No.	Madde Ayırt Edicilik Gücü	Madde Güçlük Düzeyi	Soru No.	Madde Ayırt Edicilik Gücü	Madde Güçlük Düzeyi
1	D=0.09 ZAYIF	P=0.95 KOLAY	15	D=0.14 ZAYIF	P=0.98 KOLAY
2	D=0.19 ZAYIF	P=0.90 KOLAY	18	D=0.10 ZAYIF	P=0.96 KOLAY
7	D=0.14 ZAYIF	P=0.36 ORTA	22	D=0.10 ZAYIF	P=0.96 KOLAY

Tablo 1. de görüldüğü gibi 1., 2., 7., 15., 18. ve 22. soruların madde güçlük ve ayırt edicilikleri belirtilen sınırdan altında olduğu için test dışında tutulmuştur. Bu sorulardan 1., 2. ve 15. sorular duyuşsal öğrenme alanı, 7. ve 18. sorular Bloom Taksonomisi'nin bilişsel öğrenme alanının uygulama basamağı, 22. soru Bloom Taksonomisi'nin bilişsel öğrenme alanının değerlendirme basamağını temsil eden sorulardır. Madde güçlük ve ayırt edicilik indeksi en iyi çıkan soru 29. soru olarak temsil edilen sorudur. Bu sorunun madde ayırt ediciliği 0.80 ve madde güçlüğü 0.45 olarak hesaplanmıştır. Bu soru Bloom Taksonomisi'nin bilişsel alanının uygulama basamağını temsil etmektedir.

Test, örnekleme bir kez uygulandığı zaman güvenilirlik katsayısı, testin varyansına dayalı yöntemler ve testi yarılama yöntemi kullanılarak hesaplanır (Büyüköztürk ve diğerleri, 2010). Ayrıca test puanları arasındaki iç tutarlılığı anlamak amacıyla da, Kuder-Richardson-20,21 (KR-20,21) ve alfa katsayıları kullanılır (Büyüköztürk, 2007). KR-21 formülü çoktan seçmeli maddeler ve ölçekler için kullanılır (Şencan, 2005). Bu nedenle çalışmada Kuder-Richardson 21 (KR-21) kullanılmıştır. Bu yöntemi kullanırken her bir maddeye verilen cevaplar doğru ise 1, yanlış ise 0 verilerek puanlanmıştır. Testin KR-21 puanı ise; 0.839 olarak hesaplanmıştır. Şencan (2005),

KR-21 değerinin 0.70'den büyük olması gerektiğini belirtmiştir. Hesaplanan değer 0.70'den büyük olduğu için geliştirilen bu test güvenilirdir ve aynı zamanda iç tutarlılığa da sahiptir.

Bütün bu bilgiler ışığında VüBiÇöt analiz sonuçları Tablo 2.'deki gibidir.

Tablo 2. VüBiÇöt Analiz Sonuçları

N	\bar{X}	SS	Ortanca	Mod	Varyans	Ort. Güçlük	KR-21
76	19.72	5.99	21	26	35.88	19.33	0.839

Tablo 2.'yi incelediğimizde ortanca (21) ile ortalama (19.72) birbirine yakındır. Ancak mod (26) ortanca ve ortalamadan büyüktür. Bu duruma göre testin sola çarpık olduğunu söyleyebiliriz. Testin ortalama güçlüğü 19.33, standart sapması 5.99 ve KR-21 güvenilirliği ise 0.839 olarak hesaplanmıştır. Eldeki verilere bakıldığında geliştirilen test, kullanılabilir özellikte sahiptir.

SONUÇ

5.sınıf fen bilimleri dersi 'Vücudumuz Bilmecesini Çözelim' ünitesi kazanımlarına uygun olarak sorular içeren bir başarı testi geliştirilerek ortaokul fen bilimleri öğretmenlerinin sınıf içi değerlendirme süreçlerinde kullanabilecekleri geçerli ve güvenilir bir ölçüm aracı geliştirilmesi amaçlanarak bu çalışma gerçekleştirilmiştir. Hazırlanan belirtke tablosuna bakıldığında, yeni kazanımların daha çok üst düzey becerileri kapsadığını görülmüştür. 2004 yılı fen ve teknoloji dersi öğretim programındaki kazanımlarla, 2013 yılı fen bilimleri öğretim programı kazanımlarını karşılaştırsak 2013 yılı öğretim programındaki kazanımların üst düzey becerileri daha çok içerdiği görülmektedir (MEB, 2004; MEB, 2013). Berk (1996), alan yazını incelediğinde birçok çalışmanın çoktan seçmeli testlerin üst düzey becerileri ölçemeyeceğini belirttiğini, ancak üst düzey becerileri ölçecek çoktan seçmeli bir test geliştirdiğini ve bu testin başarılı olduğunu ortaya koymuştur. Ayrıca Burton, Sudweeks, Merrill ve Wood (1991), çoktan seçmeli testlerin basit ve karmaşık becerileri ölçmede çok iyi bir araç olduğunu belirtmişlerdir (Akt. İpek Akbulut & Çepni, 2013). Bu doğrultuda üst düzey becerilerin de çoktan seçmeli test maddeleriyle ölçülebileceği sonucu çıkarılabilir.

Yapılan analizler sonucunda madde ayırt ediciliği "zayıf" olarak nitelendirilen 6 soru testten çıkarılmıştır. Bu soruların madde ayırt ediciliklerinin zayıf çıkmasının nedeni olarak soruların çeldiricilerinin güçlü olmasından dolayı kaynaklandığı düşünülmektedir. Testten çıkarılan soruları niteleyen kazanımları başka sorular da kapsadığı için, testin kapsam geçerliğinde herhangi bir değişiklik olmamıştır. Analizlerdeki ortanca (21) ile ortalamanın (19.72) birbirine yakın olduğu tespit edilmiştir. Ancak mod (26) ortanca ve ortalamadan büyüktür. Bu duruma göre testin sola çarpık olduğunu söyleyebiliriz. Yani test öğrencilere kolay gelmiştir. Testin ortalama güçlüğü 19.33, standart sapması 5.99 ve KR-21 güvenilirliği ise 0.839 olarak hesaplanmıştır. Yapılan analizler ışığında testin öğretmen, öğrenci ve araştırmacılar tarafından kullanılabilir geçerli ve güvenilir bir test olduğu sonucuna ulaşılmaktadır.

ÖNERİLER

Yapılan bu araştırma sonucu aşağıdaki öneriler geliştirilmiştir.

- 1) İlkokul ve ortaokul fen bilimleri dersinin bu ünitesi ve diğer üniteleri ile ilgili yeni başarı testleri geliştirilebilir.
- 2) Geliştirilen başarı testleri internet ortamında paylaşarak öğretmen ve öğrencilerin testten faydalanması sağlanabilir.
- 3) Öğretmen adaylarına test geliştirme dersleri verilerek, meslek hayatlarında geçerli ve güvenilir testleri kendilerinin geliştirilmesi sağlanabilir.
- 4) Öğretmenlere hizmet içi kurslarla test geliştirme konusunda dersler verilebilir.

KAYNAKLAR

- Bağcan Büyükturan, E. & Çıkrıkçı Demirtaşlı, S. (2012). "Çoktan Seçmeli Testler ile Yapılandırılmış Gridlerin Psikometrik Özellikleri Bakımından Karşılaştırılması". *Ankara Üniversitesi Eğitim Bilimleri Fakültesi Dergisi*. 45 (1), 395-415.
- Berk, R. A. (1996). *A Consumer's Guide to Multiple- Choice Item Formats That Measure Complex Cognitive Outcomes*. In National Evaluation Systems, From policy to practice Amherst.

- Börekci, C. (2010). *Bilişim Teknolojileri Dersi İçinTasarlanan BirAğ Araştırması (Webquest) Etkinliğinin Öğrenci Başarısı Üzerine Etkisi*. Yayınlanmış Yüksek Lisans Tezi. Balıkesir Üniversitesi Fen Bilimleri Enstitüsü, Balıkesir.
- Burton, S.J., Sudweeks, R.R., Merrill, P.F. & Wood, B. (1991). *How to Prepare Better Multiple- Choice Test Items: Guidelines for University Faculty*. Brigham Young University Testing Services and the Department of Instructional Science.
- Büyüköztürk, Ş. (2007). *Sosyal bilimler için veri analizi el kitabı (7. Baskı)*. PegemA Yayıncılık, Ankara.
- Büyüköztürk, Ş., Kılıç Çakmak, E., Akgün, Ö.E., Karadeniz Ş., Demirel, F. (2010). *Bilimsel Araştırma Yöntemleri*. Pegem Akademi Yayınları, 5. Baskı, Ankara.
- Çoşkun, A. (2010). *'Yeryüzünde Hareket' Konusunda Bilgisayar Destekli Eğitimin (Ortaöğretim Öğrencilerinde) Öğrenci Başarısına Etkisi*. Yayınlanmış Yüksek Lisan Tezi. Çukurova Üniversitesi Fen Bilimleri Enstitüsü, Adana.
- FEM, (2011). *KPSS Eğitim Bilimleri Ölçme ve Değerlendirme Kitabı*. Çağlayan Yayınevi, İstanbul.
- Gül, Ş. & Yeşilyurt, S. (2011). "Yapılandırıcı Öğrenme Yaklaşımına Dayalı Bilgisayar Destekli Öğretimin Öğrencilerin Tutumları ve Başarıları Üzerine Etkisi". *Necatibey Eğitim Fakültesi Elektronik Fen ve Matematik Eğitimi Dergisi (EFMED)*. 5(1), 94-115.
- Güngör, B. & Özgür, S. (2009). "İlköğretim Beşinci Sınıf Öğrencilerinin Sindirim Sistemi Konusundaki Didaktik Kökenli Kavram Yanılgılarının Nedenleri". *Necatibey Eğitim Fakültesi Elektronik Fen ve Matematik Eğitimi Dergisi (EFMED)*. 3(2), 149-177.
- Gronlund, N. E. & Linn, R. L. (1990). *Measurement and Evaluation in Teaching*, 6th ed. Macmillan Publishing Company, Newyork.
- <http://www.fenokulu.net/>
- İpek Akbulut, H. & Çepni, S. (2013). "Bir Üniteye Yönelik Başarı Testi Nasıl Geliştirilir? : İlköğretim 7. Sınıf Kuvvet ve Hareket Ünitesi". *Amasya Üniversitesi Eğitim Fakültesi Dergisi*. 2(1), 18-44.
- Özhan, K. & Odabaş, S. (2009). *Yediklim KPSS Eğitim Bilimleri Dergisi*. Eğitim Bilgisayar Yayıncılık, Ankara.
- McDonald, P. 2002. "Sustaining Fertility Through Public Policy: The Range of Options". *Population-E*, 57(3), 417-446.
- MEB, (2004). *İlköğretim 4.-5. sınıf fen ve teknoloji dersi öğretim programı*. T. C. Milli Eğitim Bakanlığı Talim ve Terbiye Kurulu Başkanlığı, Ankara.
- MEB (2013). *İlköğretim Kurumları (İlkokullar ve Ortaokullar) Fen Bilimleri Dersi Öğretim Programı*. T. C. Milli Eğitim Bakanlığı Talim ve Terbiye Kurulu Başkanlığı, Ankara.
- Uzunöz, A. & Buldan, İ. (2012). "Ortaöğretim Coğrafya Dersi Doğal Sistemler Konu Alanı Atmosfer Ve İklim Ünitesi Başarı Testi Geliştirme Çalışması". *Kastamonu Eğitim Dergisi*. 20(1), 291-312.
- Şen, E. C. & Eryılmaz, A. (2011). "Bir Başarı Testi Geliştirme Çalışması: Basit Elektrik Devreleri Başarı Testi Geçerlik Ve Güvenirlik Araştırması". *Yüzüncü Yıl Üniversitesi, Eğitim Fakültesi Dergisi*, 8(1), 1-39.
- Şencan, H. (2005). *Sosyal ve Davranışsal Ölçümlerde Güvenirlik ve Geçerlik*. Seçkin Yayıncılık, Ankara.
- Yurdabakan, İ. & Olğun, M. (2011). *Öz ve Akran Değerlendirmenin Öğrenme ve Bilişüstü Bilgi Üzerindeki Etkisi: Sonuçsal Geçerlik*. Siyasal Kitabevi, Ankara.

THE EFFECT OF INTERDISCIPLINARY NATURE EDUCATION PROGRAM ON GIFTED AND TALENTED STUDENTS' PROBLEM SOLVING SKILLS

Aims of this study are a) to develop an interdisciplinary nature education program that will help children discover that learning is a part of daily life; develop consciousness for the environment and nature by actively participating to fun and educative activities, b) to examine the effect of this program on gifted students' problem solving skills.

This study has a one group pretest-posttest design. The program developed for this study was implemented with 20 voluntary primary school students who were identified as gifted. Implementation took place in Nezahat Gökyiğit Botanical Garden, which is a natural life and teaching environment, and lasted a total of 30 hours; 6 hours a day for 5 days. The program is learner centered and based on active learning principle. It was differentiated and enriched via observations, workshops, nature themed games, empathy activities, experiments and thinking activities. Children worked individually and as a group during the activities.

The effect of the program was measured by a five point likert type scale called "Problem Solving Inventory for Primary School Children", developed by Serin, Serin and Saygılı (2010) who also conducted the reliability-validity analyses for the scale. Interviews conducted with children and observation reports written by the educators were taken into account.

Data analysis revealed that children's problem solving scores were improved significantly ($t=3,580$; $p = 0,002 < 0,05$). It was observed that the implemented program made a positive impact on children's problem solving skills.

SYNTHESIS, SPECTROSCOPIC, AND BIOLOGICAL STUDIES OF CHROMIUM(III), MANGANESE(II), IRON(III), COBALT(II), NICKEL(II), COPPER(II), RUTHENIUM(III), AND ZIRCONYL(II) COMPLEXES OF N¹, N² - BIS (3 - ((3 - HYDROXYNAPHTHALEN - 2 - YL) METHYLENE - AMINO) PROPYL) PHTHALAMIDE

Ahmed N. Al-Hakimi†, Mohamad M. E. Shakdofa‡, Ahemd M. A. El-Seidy‡, and Abdou S. El-Tabl*,§

†Department of chemistry, Faculty of science, Ibb University, Ibb, Yemen

‡Inorganic Chemistry Department, National Research Center, P.O. 12622 Dokki, Cairo, Egypt

§Department of chemistry, Faculty of science, El-Menoufia University, Shebin El-Kom, Egypt.

E-mail: asaeltabl@yahoo.com

ABSTRACT: Novel chromium(III), manganese(II), iron(III), cobalt(II), nickel(II), copper(II), ruthenium(III), and zirconyl(II) complexes of N¹,N²-bis(3-((3-hydroxynaphthalen-2-yl)methylene-amino)propyl)phthalamide (H₄L, 1) have been synthesized and characterized by elemental, physical, and spectral analyses. The spectral data showed that the ligand behaves as either neutral tridentate ligand as in complexes 2-5 with the general formula [H₄LMX₂(H₂O)]·nH₂O (M=Cu(II), Ni(II), Co(II), X = Cl or NO₃), neutral hexadentate ligand as in complexes 10-12 with the general formula [H₄LM₂Cl₆]·nH₂O (M=Fe(III), Cr(III) or Ru(III)), or dibasic hexadentate ligand as in complexes 6-9 with the general formula [H₂LM₂Cl₂(H₂O)₄]·nH₂O (M = Cu(II), Ni(II), Co(II) or Mn(II), and 13 with general formula [H₄L(ZrO)₂Cl₂]·8H₂O. Molar conductance in DMF solution indicated the non-ionic nature of the complexes. The ESR spectra of solid copper(II) complexes 2, 5, and 6 showed g_{||} > g_⊥, indicating distorted octahedral structure and the presence of the unpaired electron in the d_{x²-y²} orbital with significant covalent bond character. For the dimeric copper(II) complex [H₂LCu₂Cl₂(H₂O)₄]·3H₂O (6), the distance between the two copper centers was calculated using field zero splitting parameter for the parallel component that was estimated from the ESR spectrum. The antibacterial and antifungal activities of the compounds showed that, some of metal complexes exhibited a greater inhibitory effect than standard drug as tetracycline (bacteria) and Amphotricene B (fungi).

Keywords: Complexes, Synthesis, Schiff base, Magnetism, Biological studies

INTRODUCTION

Schiff base transition metal complexes have been of great interest for many years since they are becoming increasingly important as biochemical, analytical and antimicrobial reagents.¹ Many of metal complexes were showed anticancer and antimicrobial activities.²⁻⁴ It was reported that, some drugs have greater activity when administered as metal complexes than that as free organic compounds.⁵ So, Schiff base complexes might an untapped reservoir for drugs. Synthetic model studies involving magnetically coupled binuclear transition metal systems had attracted much interest because these studies provided deeper insights into complex biological processes. Also, homo binuclear lanthanide(III) complexes with isonicotinoyl hydrazone ligand had been prepared and characterized.⁶ Polyamino carboxylate groups had been used for the design of polydentate ligands such as ethylenediamine tetraacetic acid and diethylenetriamine penta acetic acid, generally showed high affinity for metal cations.⁷ These ligands were widely used as chelating agents in fundamental research⁸ or as diagnostic tools in the pharmaceutical industry⁹ and they are particularly suitable for magnetic resonance imaging (MRI).^{10,11} A majority of Schiff base complexes incorporating five- or six-membered metallocycles are represented by N, O- ligand environment have been published.¹² The aim of this work is the preparation, characterization and antimicrobial activity of chromium(III), manganese(II), iron(III), cobalt (II), nickel(II), copper(II), ruthenium(III), and zirconyl (II) complexes of N¹,N²-bis(3-((3-hydroxynaphthalen-2-yl)methylene amino)propyl)phthalamide (H₄L).

EXPERIMENTAL

All chemicals and solvents were reagent grade commercial material and used as received. Elemental analyses for (C, H, N, Cl) were determined at the Analytical Unit of Cairo University, Egypt. Standard analytical methods were used to determine the metal ion content.¹³ IR spectra of the ligand and its metal complexes were measured using KBr discs with a Jasco FT/IR 300E Fourier transform infrared spectrophotometer covering the range 400-4000 cm⁻¹ and in the 500-100 cm⁻¹ region using polyethylene-sandwiched Nujol mulls on a Perkin Elmer FTIR 1650 spectrophotometer. Mass spectrum of the ligand recorded using a JEOL JM-S-AX-500 mass spectrometer. Electronic absorption spectra in the 200-900 nm regions were recorded on a Perkin-Elmer 550 spectrophotometer.

Magnetic susceptibilities were measured at 25 °C by the Gouy method using mercuric tetrathiocyanatocobaltate(II) as the magnetic susceptibility standard. The magnetic moments were calculated from the equation:

$\mu_{\text{eff.}} = 2.84 \sqrt{\chi^{\text{corr}}_{\text{M}} \cdot T}$. Molar conductance was measured on a Tacussel type CD₆NG conductivity bridge using 10⁻³ M DMF solutions. Thermal analyses (DTA and TG) were carried out in air using a Shimadzu DT-30 thermal analyzer. The ESR spectra of the solid complexes at room temperature and at 77 K were recorded using a Varian E109 spectrophotometer (Leicester University, England). DPPH was used as the marker. TLC was used to confirm the purity of the prepared compounds.

Preparation of the ligand

Ethylphthalate was prepared using a published procedure.¹⁴

Preparation of N¹,N²-bis(3-aminopropyl)phthalamide: The N¹,N²-bis(3-aminopropyl)phthalamide was prepared (Fig. 1) by the dropwise addition of ethanol solution (50 cm³) of ethyl phthalate (5.0 g, 0.22 mol) to the ethanol solution (25 cm³) of 1,3-diaminopropane (3.33 g, 0.044 mol) with gentle warming and stirring for one hour. The white precipitate formed was filtered off, washed with ethanol, and dried under vacuum over anhydrous CaCl₂.

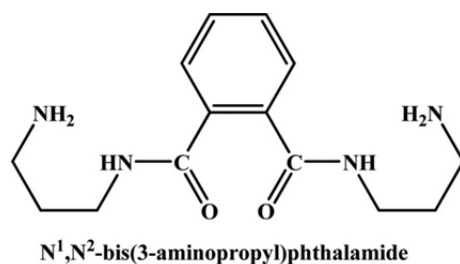

Fig. 1.

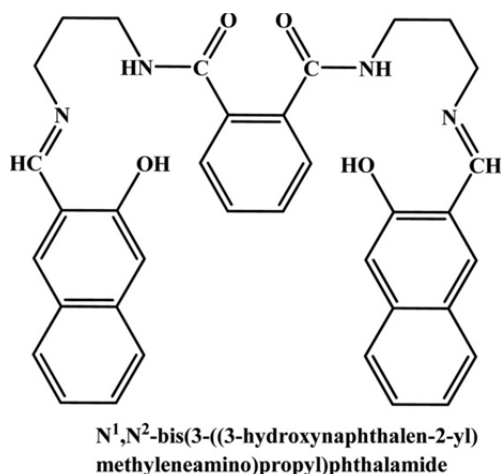

Fig. 2. Structure representation of the ligand.

Preparation of the ligand (H₄L, 1): The ligand (H₄L, 1) (Fig. 2) was prepared by adding hot ethanol solution (50 cm³) of N¹,N²-bis(3-aminopropyl)phthalamide (5.0 g, 0.018 mol) to a hot ethanol solution (50 cm³) of naphthaldehyde (6.19 g, 0.036 mol). The mixture was refluxed for two hours and left to cool at room temperature. The yellow product was filtered off, washed with ethanol and dried under vacuum over anhydrous CaCl₂.

Preparation of metal complexes

Complexes 2-5 were prepared by the dropwise addition of a hot (60 °C) methanol solution of CuCl₂·2H₂O, NiCl₂·6H₂O, CoCl₂·6H₂O or Cu(NO₃)₂·2.5H₂O to a hot (70 °C) ethanol solution of the ligand in molar ratio

1:1M/L (Metal/Ligand). The mixture was refluxed for four hours. The precipitates formed after cooling were filtered, washed with ethanol, then with diethyl ether and dried under vacuum over anhydrous CaCl_2 .

Complexes 6-13 were prepared by mixing a hot (60°C) methanol solution of $\text{CuCl}_2 \cdot 2\text{H}_2\text{O}$, $\text{NiCl}_2 \cdot 6\text{H}_2\text{O}$, $\text{CoCl}_2 \cdot 6\text{H}_2\text{O}$, $\text{Mn}(\text{Cl})_2 \cdot 4\text{H}_2\text{O}$, $\text{FeCl}_3 \cdot 6\text{H}_2\text{O}$, $\text{RuCl}_3 \cdot 3\text{H}_2\text{O}$, $\text{CrCl}_3 \cdot 6\text{H}_2\text{O}$ or $\text{ZrOCl}_2 \cdot 8\text{H}_2\text{O}$ with a hot (70°C) ethanol solution of the ligand in molar ratio 2:1 M/L (Metal/Ligand). The mixture was refluxed for four hours. The precipitates formed after cooling were filtered, washed with ethanol, then with diethyl ether and dried under vacuum over anhydrous CaCl_2 .

In-vitro antibacterial and antifungal activities

The investigation of the biological activities of the newly synthesized Schiff base ligand, its metal complexes and their corresponding metal salts were carried out in the Botany Department Lab. of microbiology, Faculty of Science, El-Menoufia University. The antibacterial and antifungal activities were investigated by disc diffusion method.^{15,16} The antibacterial activities were done using *Escherichia coli* and *Aspergillus niger* at 2000 ppm concentrations in DMSO. DMSO poured disc was used as negative control. The bacteria were subcultured in nutrient agar medium which was prepared using ($\text{g} \cdot \text{L}^{-1}$ distilled water) NaCl (5 g), peptone (5 g), beef extract (3 g), agar (20 g). The fungus was subcultured in Dox's medium which was prepared using ($\text{g} \cdot \text{L}^{-1}$ distilled water) yeast extract (1g), sucrose (30 g), NaNO_3 , agar (20 g), KCl (0.5 g), KH_2PO_4 (1 g), $\text{MgSO}_4 \cdot 7\text{H}_2\text{O}$ (0.5 g) and trace of $\text{FeCl}_3 \cdot 6\text{H}_2\text{O}$. These mediums were then sterilized by autoclaving at 120°C for 15 min. After cooling to 45°C the medium was poured into 90 mm diameter Petri dishes and incubated at 37°C or 28°C , respectively. After few hours, Petri dishes were stored at 4°C . Microorganisms were spread over each dish by using sterile bent loop rod. The test is carried out by placing filter paper disks with a known concentration of the compounds on the surface of agar plates inoculated with a test organism. Standard antibacterial drug (tetracycline), antifungal drug (Amphotericin B) and solution of metal salts were also screened under similar conditions for comparison. The Petri dishes were incubated for 48 h at 37°C or 28°C , respectively. The zone of inhibition was measured in millimeters carefully. All determinations were made in duplicated manner for each of the compounds. An average of the two independent readings for each compound was recorded.

RESULT AND DISCUSSION

All the prepared compounds are colored, non-hygroscopic, crystalline solid and stable at room temperature. The complexes are insoluble in non-polar solvents but soluble in polar coordinating solvents such as DMSO and DMF. Elemental analyses, physical data, Table 1, and spectral data, Tables 2 and 3 are compatible with the proposed structures shown in Fig. 4. To date, no diffractable crystals have been grown.

N^1, N^2 -bis(3-((3-hydroxynaphthalen-2-yl)methyleneamino)propyl)phthalamide (H_4L) can exist in the keto form (I), keto-enol form (II), enol form (III), Fig. 3. 113

H- and C-NMR spectra of 1

The ^1H -NMR spectrum of the ligand (H_4L , 1) in $d^6\text{DMSO}$ shows signals consistent with the proposed structure (Fig. 2) and indicated that, the ligand is present in its ketonic form.¹⁷ This conclusion was supported by the presence of peaks due to NH groups appearing at 8.62 ppm (s, 2H)^{18,19} and azomethine group $\text{HC}=\text{N}$ appearing at 8.12 ppm (s, 2H).²⁰ The peak appeared at 10.1 ppm, may be due to the proton of hydroxyl groups (s, 2H).²¹ The peaks appearing in the 7.04-7.85 ppm range may correspond to protons of the aromatic hydrogen (16H). The signals at 3.96, 3.51 and 2.1 ppm may be assigned to terminal $-\text{CH}_2-\text{N}=\text{C}$, terminal $-\text{CH}_2-\text{NH}$ and middle $-\text{CH}_2-$ groups. The ^{13}C -NMR spectrum showed different peaks appearing at 182.1 and 160.23 ppm. These peaks can be due to $-\text{CH}=\text{N}-$ and $-\text{C}-\text{OH}$ groups respectively,²¹ however the peaks at 127.63-140.2 ppm range assigned to the carbon of aromatic ring.²¹ The peaks appearing at 60.22 and 31.52 ppm may be due to terminal $-\text{CH}_2-\text{N}$ - and middle $-\text{CH}_2-$ group carbons.²²

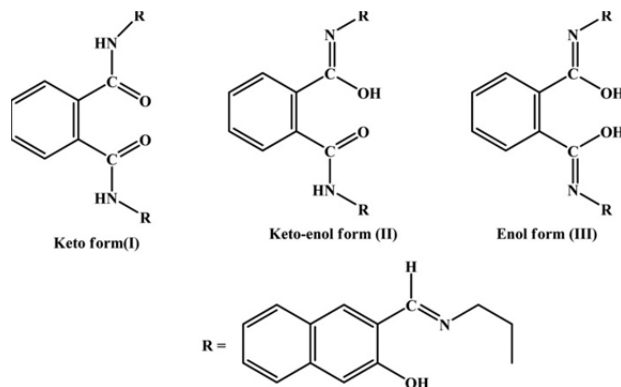

Table 1. Elemental analyses and physical properties of the ligand (H₄L) and its metal complexes

No. Ligand/complexes	Colour	Yield %	M.P (C ⁰)	$\Omega^{-1}\text{mol}^{-1}\text{cm}^2$	μ_{eff} (B.M)	Found (Calc.) %				
						C	H	N	Cl	M
(1) [(H ₄ L)] [C ₃₆ H ₃₄ N ₄ O ₄	Yellow	90	200	----	-----	73.54(73.70)	5.64(5.84)	9.60 (9.55)	----	-----
(2) [(H ₄ L)CuCl ₂ (H ₂ O)]	Green	85	295	15	1.73	58.40(58.50)	5.11(4.91)	7.70(7.58)	9.40(9.59)	8.50(8.60)
(3) [(H ₄ L)NiCl ₂ (H ₂ O)].H ₂ O	D. green	80	>300	12	2.8	57.35(57.48)	5.22(5.09)	7.80(7.45)	9.60(9.43)	7.90(7.80)
(4) [H ₄ LCuCl ₂ H ₂ O].2H ₂ O	Brown	87	280	23	4.8	56.00(56.13)	5.30(5.23)	7.50(7.27)	9.00(9.20)	7.40(7.62)
(5) [(H ₄ L)Cu(NO ₃) ₂ (H ₂ O)].2H ₂ O	Brown	80	300	21	1.7	52.00(52.20)	5.16(4.87)	10.3(10.15)	-----	7.70(7.67)
(6) [(H ₂ L)Cu ₂ Cl ₂ (H ₂ O) ₄].3H ₂ O	Brown	81	245	22	1.5	47.49(47.58)	5.20(5.10)	6.40(6.17)	8.30(7.80)	14.2(13.99)
(7) [(H ₂ L)Ni ₂ Cl ₂ (H ₂ O) ₄].H ₂ O	D. green	77	290	15	1.87	50.00(50.10)	5.00(4.91)	6.70(6.49)	8.30(8.22)	13.51(13.60)
(8) [(H ₂ L)Co ₂ Cl ₂ (H ₂ O) ₄].2H ₂ O	Brown	75	285	23	2.83	48.90(49.08)	5.11(5.03)	6.70(6.36)	8.00(8.05)	13.51(13.32)
(9) [(H ₂ L)Mn ₂ Cl ₂ (H ₂ O) ₄].H ₂ O	Brown	82	280	15	3.8	50.40(50.54)	5.06(4.95)	6.90(6.55)	8.40(8.29)	12.90(12.84)
(10) [(H ₄ L)Fe ₂ Cl ₆].H ₂ O	D. brown	75	>300	18	3.69	46.60(46.54)	4.07(3.91)	-----	-----	6.20(6.03)
(11) [(H ₄ L)Cr ₂ Cl ₆].2H ₂ O	D. brown	83	>300	12	2.85	45.90(46.00)	4.20(4.08)	-----	-----	6.20(5.96)
(12) [(H ₄ L)Ru ₂ Cl ₆].3H ₂ O	Black	80	290	14	2.1	40.83(40.96)	3.88(3.82)	5.60(5.31)	20.40(20.15)	19.00(19.15)
(13) [(H ₂ L)(ZrO) ₂ Cl ₂].8H ₂ O	Yellow	85	>300	20	Dia.	42.40(42.64)	5.03(4.77)	5.60(5.52)	7.00(6.99)	20.91(21.15)

D = Dark $\Omega^{-1}\text{mol}^{-1}\text{cm}^2$ in 10^{-3} M DMF

Table 2. IR spectra (assignments) of the ligand (1) and its metal complexes

NO.	H ₂ O _{hydr./coord.}	$\nu(\text{OH})$	$\nu(\text{NH})$	$\nu(\text{C}=\text{O})$	$\nu(\text{C}=\text{N})$	$\nu(\text{C}-\text{O})$	$\nu(\text{M}-\text{O})$	$\nu(\text{M}-\text{N})$	$\nu(\text{M}-\text{Cl})$
(1)	-	3360s	3252s	1656v.s	1620s	1315m	---	---	---
(2)	3452br	3361s, 3341m	3254s, 3239m	1655v.s	1621s, 1609m	1317m, 1325m	680m	570m	402w
(3)	3580-3445br	3362s, 3338m	3250s, 3237m	1654v.s	1623s, 611m	1316m, 1325m	656m	565	382w
(4)	3620-3450br	3358s, 340m	3249s, 3241m	1655v.s	1621s, 607m	1314m, 1321m	690m	565m	398w
(5)	3610-3440br	3359s, 3346m	3250s, 3235m	1653v.s	1624s, 1606m	1315m, 1328m	660m	560m	-----
(6)	3625-3454br	-	3239m	1655v.s	1605m	1325m	670m	550m	385m
(7)	3605-3449br	-	3235m	1657v.s	1608m	1330m	690m	590m	410m
(8)	3600-3455br	-	3225m	1656v.s	1611m	1338m	675m	565m	380w
(9)	3612-3450br	-	3231m	1655v.s	1604m	1335m	680m	565m	380w
(10)	3580br	3349m	3236m	1657v.s	1606m	1330m	670m	605m	375m
(11)	3590br	3344m	3239m	1656v.s	1605m	1325m	650m	570m	365m
(12)	3585br	3347m	3239m	1658v.s	1610m	1329m	670m	595m	405m
(13)	3605br	-	3235m	1655v.s	1612m	1339m	650m	570m	413m

Fig. 3.

Mass spectra

The mass spectrum of the ligand reveals the molecular ion peak (m/z) 587 a.m.u consistent with the molecular weight of the ligand. The most fragments appear at (m/z) 77, 144, 163, 170, 248 and 417 a.m.u corresponding to [C₆H₅], [C₁₀H₈O], [C₁₀H₁₃NO], [C₁₁H₈NO], [C₁₄H₂₀N₂O₂], and [C₂₅H₂₇N₃O₃], respectively (Fig. 5). However copper(II) complexes 2 and 6 show molecular ion peaks (m/z) at 739 and 908a.m.u., consisted with the molecular weights of 739.15 and 908.79 respectively.

Conductivity measurements

The molar conductance values of the complexes in DMF (10^{-3} M), lie in the 12-23.2 $\Omega^{-1}\text{mol}^{-1}\text{cm}^2$ range, Table 1, indicating that, all the complexes are not electrolytes. These confirmed that the anion is coordinated to metal ion.^{23,24}

IR spectra

The IR spectral data for the ligand (H₄L, 1) and its metal

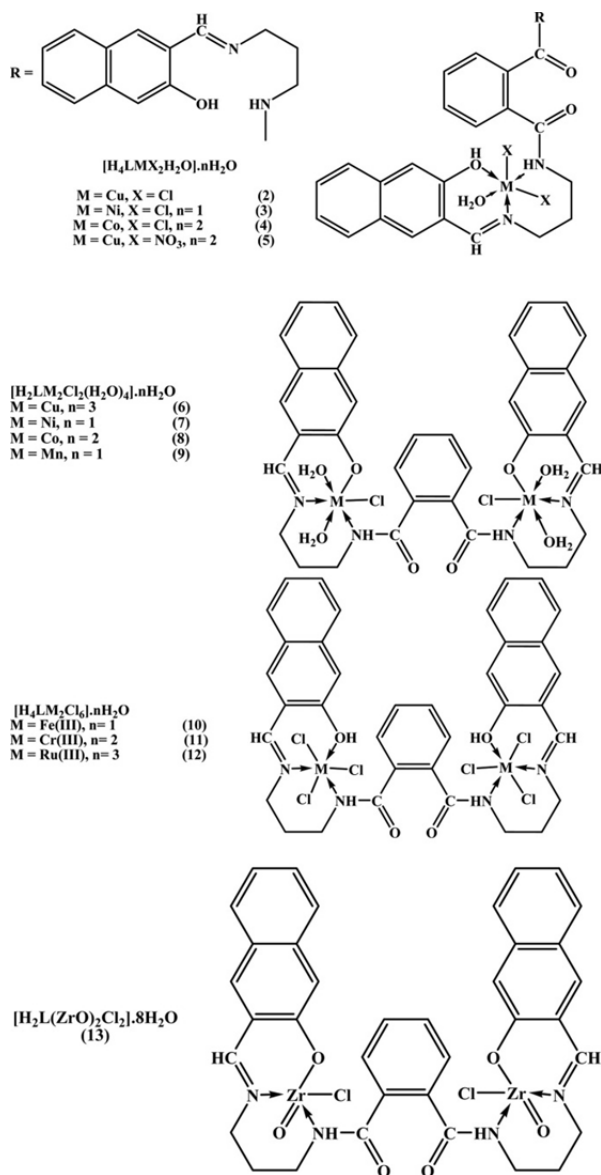

Fig. 4. Structure representation of metal complexes.

complexes are presented in Table 2. The IR spectrum of the ligand showed bands at 3360 and 3252 cm^{-1} may be due to $\nu(\text{OH})$ and $\nu(\text{NH})$ group.¹⁹ However, broad, medium bands were observed in the 3450-3200 and 3180-2600 cm^{-1} ranges, attributed to intra- and intermolecular hydrogen bonding between -OH and -C=N, -NH and -C=O groups respectively^{19,25} thus, the higher frequency band is associated with a weaker hydrogen bond and the lower frequency band with a stronger hydrogen bond. Also, the spectrum shows bands at 1656 and 1620 and 1586 cm^{-1} which were assigned to $\nu(\text{C=O})$, $\nu(\text{C=N})$ and $(\text{C=C})_{\text{Ar}}$ respectively.^{26,27} The spectra of solid complexes are compared with those of the ligand in order to know the mode of bonding. The spectra showed that the ligand behaved either as:

Neutral tridentate ligand, coordinating through OH, C=N, and NH of one arm of the ligand as in case of complexes 2-5, the mode of coordination was suggested by the following evidence: i) the bands due to OH, C=N, and NH were shifted to lower wave number with decreasing their intensities, while the other ones found almost at their original place, indicating that, only one of each pair were involved in the coordination,^{19,25,28-30} ii) one band of the two C-O bands was shifted to a higher wave number while the other is found almost at its original place, indicating that, only one phenolic oxygen was involved in the coordination,²⁸ iii) the band of both carbonyl groups found as one band almost at its original place in the ligand indicating that they are not involved in the coordination,^{18,26,27} iv) the simultaneous appearance of new bands in the 656-690 and 560-570 cm^{-1} regions are due to the $\nu(\text{M-N})$ and $\nu(\text{M-O})$ vibrations,^{31,32} respectively.

Bibasichexadentate ligand, coordinating through all O⁻, C=N and NH groups as in case of complexes 6-9 and 13, the mode of coordination was suggested by the following evidence: i) the disappearance of the band of the two OH groups,²⁸ ii) the bands of C=N and NH groups were shifted to lower wave number with decreasing their intensities, indicating that, all C=N and NH groups were involved in the coordination,^{19,25,29,30} iii) the band of two C-O groups were shifted to higher wave number, indicating that, both phenolic oxygen atoms were involved in the coordination²⁸ iv) the bands of both carbonyl groups were observed as single band at its original place in the ligand indicating that, they are not involved in the coordination,^{18,26,27} iv) the simultaneous appearance of new bands in the 650-690 and 550-590 cm⁻¹ regions are due to the $\nu(\text{M-N})$ and $\nu(\text{MO})$ vibrations, respectively.^{31,32}

Neutral hexadentate ligand, coordinating through all OH, C=N and NH groups as in case of complexes 10-12, the mode of coordination was suggested by the following evidence: i) the bands of C=N, OH and NH groups were shifted to lower wave number with decreasing their intensities, indicating that, all C=N, OH and NH groups were involved in the coordination,^{19,25,28-30} iii) the band of both C-O groups were shifted to higher wave number, indicating that, all hydroxyl groups were involved in the coordination²⁸ iv) the bands of both carbonyl groups were observed as single band at its original place in the ligand indicating that, they are not involved in coordination,^{18,26,27} iv) the simultaneous appearance of new bands in the 650-670 and

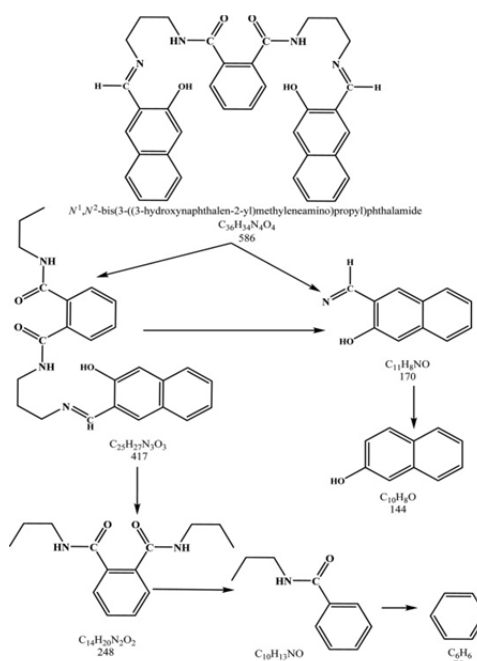

Fig. 5. The fragmentation pattern of the ligand.

570-605 cm⁻¹ regions are due to the $\nu(\text{M-N})$ and $\nu(\text{M-O})$ vibrations, respectively.^{31,32} All complexes except complex 5, show band in the 375-413 region, assignable to $\nu(\text{M-Cl})$.^{19,28} The broad bands in the 3600-3400 cm⁻¹ region are due to coordinated water or water of crystallization. Complexes 2-9 showed a band in the 400-600 cm⁻¹ region indicating the presence of coordinated water, but the absence of these bands in the spectra of complexes 10-13 indicate the presence of hydrated water rather than coordinated ones. The presence of water molecules within the coordination sphere in the hydrated complexes 2-9 is further supported by the presence of bands in the 3480-3494, 1605-1610, 940-950 and 613-630 cm⁻¹ regions due to OH stretching, HOH deformation, H₂O rocking and H₂O wagging, respectively.^{33,34} The spectrum of the complex 5 showed bands at 1465 cm⁻¹ (ν_1), 1050 cm⁻¹ (ν_2), 1377 cm⁻¹ (ν_4) and 710 cm⁻¹ (ν_5) with ν_1 - ν_4 separation of 88 cm⁻¹, characteristic of monodentate nitrate group.³⁵ Zirconyl(II) complex 13 shows band at 825 cm⁻¹ assigned to Zr=O.¹⁹

Electronic spectra

The electronic spectral data of the ligand (H₄L, 1) and

Table 3. UV-Vis. spectra of the ligand, (H₄L) and its metal complexes

No.	Compounds	λ_{\max} , nm (ϵ mol ⁻¹ cm ⁻¹)
(1)	[(H ₄ L)] [C ₃₆ H ₃₄ N ₄ O ₄	320(3684), 370(2787)
(2)	[(H ₄ L)CuCl ₂ (H ₂ O)]	315(2320), 345(2966), 450(791), 590(232), 640(58)
(3)	[(H ₄ L)NiCl ₂ (H ₂ O)].H ₂ O	305(1699), 345(2295), 490(476), 580(188), 610(151), 865(189)
(4)	[H ₄ LCoCl ₂ H ₂ O].2H ₂ O	315(2360), 455(3654), 610(370), 665(190)
(5)	[(H ₄ L)Cu(NO ₃) ₂ (H ₂ O)].2H ₂ O	315(2464), 345(1947), 430(992), 585(66)
(6)	[(H ₂ L)Cu ₂ Cl ₂ (H ₂ O) ₄].3H ₂ O	305(3497), 345(2057), 460(764), 580(257), 625(170)
(7)	[(H ₂ L)Ni ₂ Cl ₂ (H ₂ O) ₄].H ₂ O	305(3236), 345(2330), 510(497), 600(388), 870(104)
(8)	[(H ₂ L)Co ₂ Cl ₂ (H ₂ O) ₄].2H ₂ O	300(2457), 475(1654), 590(296), 650(135)
(9)	[(H ₂ L)Mn ₂ Cl ₂ (H ₂ O) ₄].H ₂ O	325(3714), 430(2844), 480(636), 590(85)
(10)	[(H ₄ L)Fe ₂ Cl ₆].H ₂ O	290(2204), 310(5176), 400(1390), 600(92)
(11)	[(H ₄ L)Cr ₂ Cl ₆].2H ₂ O	315(2153), 460(3700), 500(429), 540(38)
(12)	[(H ₄ L)Ru ₂ Cl ₆].3H ₂ O	305(4097), 430(3465), 460(969), 665(25)
(13)	[(H ₂ L)(ZrO) ₂ Cl ₂].8H ₂ O	320(2885), 370 (4464), 430(594)

its metal complexes in DMF solution are summarized in Table 3. The ligand (H₄L, 1) showed two bands at 370 and 320 nm which may be assigned to n→π* and π→π* transitions respectively.³² In the metal complexes, the spectra showed bands in the 345-290 nm range, due to intraligand transitions. Copper(II) complexes 2, 5, and 6 in DMF solution showed bands in the 430-460, 580-590 and 625-640 nm range, which were assigned to ligandcopper(II) charge transfer, ²B₁→²E and ²B₁→²B₂ transitions indicating a distorted octahedral structure.^{36,37} Nickel(II) complexes 3 and 7 showed bands in 490-510, 600-610 and 865-870 nm ranges respectively, which are attributable to

$3 \quad 3 \quad 3 \quad 3 \quad 3$
 $A_{2g}(F) \rightarrow T_{1g}(P)$ (ν_3), $A_{2g}(F) \rightarrow T_{1g}(F)$ (ν_2) and $A_{2g}(F) \rightarrow 3 T_{2g}(F)$ (ν_1) transitions indicating octahedral nickel(II) complexes.^{38,39} The ν_2/ν_1 ratio for these complexes were 1.41 and 1.45 respectively, which is less than the usual range of 1.5-1.75, indicating distorted octahedral nickel(II) complexes.³⁷ The cobalt(II) complexes 4 and 8 showed bands at 455-475, 590-610 and 650-665 nm ranges, which were assigned to $4T_{1g}(F) \rightarrow 4T_{1g}(P)$, $4T_{1g}(F) \rightarrow 4A_{2g}$ and $4 \quad 4$
 $T_{1g}(F) \rightarrow T_{2g}(F)$ transitions respectively, corresponding to high spin cobalt(II) octahedral complexes.^{19,40} Manganese(II) complex 9 showed bands at 430, 480 and 590 nm, these bands were corresponding to $6A_{1g} \rightarrow 4E_g$, $6A_{1g} \rightarrow 4T_{2g}$ and $6A_{1g} \rightarrow 4T_{1g}$ transitions which are compatible to an octahedral structure for manganese(II) complexes.^{41,42} Iron(III) complex 10 gave bands at 400 and 600 nm are due to charge transfer and $6A_1 \rightarrow 4T_1$ transitions, suggesting octahedral structure.^{19,36,42} Chromium(III) complex 11

showed bands at 460 and 540 nm which are attributed to charge transfer and $4A_2 \rightarrow 4T_1$ transitions of six coordinate chromium(III) complex.^{43,44} Ruthenium(III) complex 12 showed bands at 460 and 665 nm, are due to LMCT transition and the other one is assigned to $2T_{2g} \rightarrow 2A_{2g}$ transition. These band were similar to those observed for octahedral ruthenium(III) complexes.^{19,45,46} Zirconyl(II) complex 13 shows bands (Table 3) were due to intraligand transitions.

Magnetic moments

The room temperature magnetic moments of complexes 2-14 are present in Table 1. Copper(II) complexes 2, 5 and 6 show values 1.73, 1.7 and 1.5 B.M.. These values are correspond to one unpaired electron in an octahedral structure.¹⁹ Nickel(II) complexes 3 and 7 show values 2.8 and 1.87 B.M., indicating octahedral nickel(II) complexes.^{19,47,48} Cobalt(II) complexes 4 and 8 show values 4.8 and 2.83 B.M., indicating high spin octahedral cobalt (II) complexes.^{19,38} Manganese(II) complex 9 shows 3.8

B.M., suggesting octahedral geometry around the manganese(II) ion.^{19,38} Iron(III) complex shows 3.69 B.M., indicating high spin iron(III) octahedral geometry.^{19,50} Chromium(III) complex 11 shows 2.85 B.M., which is lower than the spin-only value, implying an operation of spin-exchange interactions take place between chromium (III) ions.⁴⁴ The ruthenium(III) complex 12 shows a magnetic value of 1.67 B.M., indicating an octahedral ruthenium(III) structure.^{19,51} Zirconyl(II) complex 13 shows diamagnetic property.¹⁹ The complexes 6-11 showed low magnetic moment values indicating spin exchange interactions take place between the two ion centers.^{19,47,49}

ESR spectra

The ESR spectra of solid copper(II) complexes 2, 5 and 6 at room and at liquid nitrogen temperatures were characteristic of a d⁹ system and having an axial symmetry type of a d_{x²-y²} ground state.⁵² On lowering the temperature to liquid nitrogen, the spectra were not changed, suggesting that, the geometry of the complexes is

not changed on cooling. The g -values suggest octahedral geometry for complexes 2, 5 and 6. The complexes show $g_{\parallel} > g_{\perp} > g_e$, indicating a $d_{x^2-y^2}$ ground state, and spectral features were characteristic of axial symmetry.⁵³ The ESR parameters for 2 is $g_{\parallel} = 2.27$, $g_{\perp} = 2.05$, $g_{iso} = 2.13$, $G = 5.4$, $K_{\perp}^2 = 0.64$, $K_{\parallel}^2 = 0.68$, $K^2 = 0.65$ and $K = 0.81$, for 5 is $g_{\parallel} = 2.24$, $g_{\perp} = 2.06$, $g_{iso} = 2.12$, $G = 4.0$, $K_{\perp}^2 = 0.81$, $K_{\parallel}^2 = 0.61$, $K^2 = 0.74$ and $K = 0.86$, for 6 is $g_{\parallel} = 2.26$, $g_{\perp} = 2.08$, $g_{iso} = 2.14$, $G = 3.25$, $K_{\perp}^2 = 1.02$, $K_{\parallel}^2 = 0.67$, $K^2 = 0.9$ and $K = 0.95$. Kivelson and Neiman⁵⁴ show that, the g_{\parallel} -value in the copper(II) complexes can be used as a measure of covalent character of the metal-ligand bond. If this value is greater than 2.3, the environment is essentially ionic and the value less than this limit indicate a covalent environment. All complexes showed covalent bond character.^{19,54,55} The g -values were related by the expression,⁵⁶ $G = (g_{\parallel}-2)/(g_{\perp}-2)$, if $G > 4.0$ then local tetragonal axes were aligned parallel or only a slightly misaligned, if $G < 4.0$, significant exchange coupling is present. Complexes 2 and 5 show value ≥ 4.0 , however complex 6 shows $G = 3.25$, indicating spin-exchange interactions take place between the copper(II) ions, which is further confirmed from the magnetic moment value (Table 1). Also, the g -values of copper(II) complexes with a ${}^2B_{1g}$ ground state ($g_{\parallel} > g_{\perp}$) may be expressed.^{35,57}

$$K_{\perp}^2 = (g_{\perp} - 2.002)\Delta E_{xz}/2\lambda^0 \quad (1)$$

$$K_{\parallel}^2 = (g_{\parallel} - 2.002)\Delta E_{xy}/8\lambda^0 \quad (2)$$

$$K^2 = (K_{\parallel}^2 + 2K_{\perp}^2)/3 \quad (3)$$

Where K_{\parallel} and K_{\perp} were the parallel and perpendicular components respectively of the orbital reduction factor (K), λ^0 is the spin-orbit coupling constant for the free copper, ΔE_{xy} and ΔE_{xz} were the electron transition energies. From the above relations, the orbital reduction of covalency^{35,57} can be calculated for an ionic environmental, $K=1$ and for a covalent environment $K<1$, the lower the value of K , the greater is the covalent character. The K -values of the complexes 2, 5, and 6 were lower than 1.0, confirming covalent bond character.^{19,35,58} The ESR spectra of 4, 9, and 10 showed isotropic type with $g_{iso} = 2.21$, 2.012 and 2.0035, indicating octahedral geometry around Co(II), Mn(II), and Fe(III) ions respectively.^{54,57}

The zero field splitting parameter (D) for the parallel components of the dimer complex 6 was estimated from the spectrum, and is equal to 414. The distance between two copper centers was calculated using the following equation.⁵⁹

$$D = (3\mu_B / 2R^3) * (3 \cos^2 \theta - 1) \quad (4)$$

Where μ_B is the magnetic moment of the electron and R is the distance (\AA) between two electrons. For parallel component (D), $\theta=0$, by substitution in equation 4, D is equal to $3 \mu_B/2R^3$. For a diradical system in the triplet-state, it is found that, D for the parallel components is equal to 402 G and the distance between the two radicals is equal to 5.2 \AA . From these data, the distance between the two copper(II) centers was calculated and is equal to 5.3 \AA . This value is close to that for a dimeric copper(II) compound in the triplet state.⁶⁰

Thermal analyses (DTA and TG)

The results of TG and DTA analyses of complexes were shown in Table 4. The results showed good agreement with theoretical formula as suggested from the analytical data (Table 1). All complexes except complex 2, lost hydration water molecules in the temperature 78-90 $^{\circ}\text{C}$ range and were accompanied with an endothermic peak. The coordinated water molecules were eliminated from these complexes at relatively higher temperature; 110-142 $^{\circ}\text{C}$, than those of the hydrate water molecules (Table 4). The removal of HCl molecules was observed for all complexes in the temperature 190-240 $^{\circ}\text{C}$ range, which was accompanied by an endothermic peak. The complexes decompose through degradation of the Schiff base ligand at a temperature over than 400 $^{\circ}\text{C}$ leaving metal oxides (480-590) range.

Biological activity

The antibacterial and antifungal activities of the ligand and its metal complexes were screened on bacterial and fungal strains using the disk diffusion method. It is important to note that the ligand and most of its metal complexes exhibit more antifungal inhibitory effects than the Standard antifungal drug (amphotericin B) and most of the metal complexes more active than parent ligands and the solution of metal ions. It is also clear that the ligand and its metal complexes have more antifungal activity than antibacterial activity. The inhibition zone diameter of the compounds is shown in Figs. 6 and 7. The order of antifungal activity of the compounds is 9, 10 > 6, 11 > 12 > 5 > Ligand > Amphotericin B > 7, however, the order of antibacterial activity of the compounds is Tetracycline > 11, 12 > 9 > 6 > 5 > 7. The increased activity of the metal complexes can be explained on the basis of chelation theory.⁶¹ It is known that the chelation tends to make the

No.	Temp. (C)	DTA (peak)		TGA (Wt. loss %)		Assignment
		Endo	Exo	Calc.	Found	
Table 4. Thermal data for the metal complexes						
(2)	119	endo	---	2.4	2.5	Loss of coordinated water (1 H ₂ O)
	230	endo ----	exo	9.6	9.5	Loss of chloride atom (2Cl)
	450					
	590	----	exo	10.8	10.7	Decomposition with the formation of CuO
(3)	90	endo	endo ----	2.5	2.6	Loss of hydration water (1H ₂ O)
	142	endo	----	2.5	2.5	Loss of coordinated water (1H ₂ O)
	240	----	---exo	9.7	9.5	Loss of chloride atom (2Cl)
	350					
	420	----	exo			
550	----	exo	10.2	10.1	Decomposition with the formation of NiO	
(4)	85	endo	endo ----	4.7	4.6	Loss of hydration water (2H ₂ O)
	118	endo	----	2.3	2.3	Loss of coordinated water (1H ₂ O)
	225		----	9.2	9.1	Loss of chloride atom (2Cl)
	350	----	exo			
	570	----	exo	9.7	9.6	Decomposition with the formation of CoO
(6)	80	endo	endo -----	6.1	6.0	Loss of hydration water (3H ₂ O)
	140	endo	-	8.1	8.1	Loss of coordinated water(4H ₂ O)
	220			8.0	8.1	Loss of chloride atom (2Cl)
	450	----	exo			
	550	----	exo	17.9	18.0	Decomposition with the formation of (2CuO)
(7)	78	endo	endo -----	2.1	2.3	Loss of hydration water (H ₂ O)
	115	endo	-	8.4	8.5	Loss of coordinated water(4H ₂ O)
	210			8.2	9.1	Loss of chloride atom (2Cl)
	450	----	exo			
	500	----	exo	17.3	17.1	Decomposition with the formation of (2NiO)
(9)	80	endo	endo -----	2.1	2.3	Loss of hydration water (H ₂ O)
	110	endo	-	8.4	8.5	Loss of coordinated water(4H ₂ O)
	190			8.2	9.1	Loss of chloride atom (2Cl)
	450	----	exo			
	480	----	exo	16.6	16.3	Decomposition with the formation of (2MnO)
(10)	85	endo	----	1.9	2.0	Loss of hydration water (H ₂ O)
	215	endo	----	22.5	22.3	Loss of chloride atom (6Cl)
	450	----	exo			
(13)	580	----	exo	33.7	33.5	Decomposition with the formation of (2Fe ₂ O ₃)
	90	endo	----	14.2	14.5	Loss of hydration water (8H ₂ O)
	205	endo	----	1.1	0.9	Loss of chloride atom (2Cl)
	450	----	exo			
	540	----	exo	24.3	24.9	Decomposition with the formation of (2ZrO ₂)

ligand act as more powerful and potent fungicidal and bactericidal agents, thus killing more fungi and bacteria than the ligand. It is known that, in a complex, the positive charge of the metal is partially shared with the donor atoms present in the ligands, and there may be π -electron delocalization over the whole chelating system,⁶² this

increases the lipophilic character of the metal chelate and favors its permeation through the lipid layer of the membranes. There are other factors which also increase the activity, which are solubility, conductivity, coordination mode and bond length between the metal and the ligand. The variation in the effectiveness of different compound against different organisms also depends either on the impermeability of the cell of the microbes or differences in ribosomes of microbial cells.^{63,64} The variation of biological activity of the complexes may be due to change in electronic configuration of the metal and also, the environment around the metal ion.

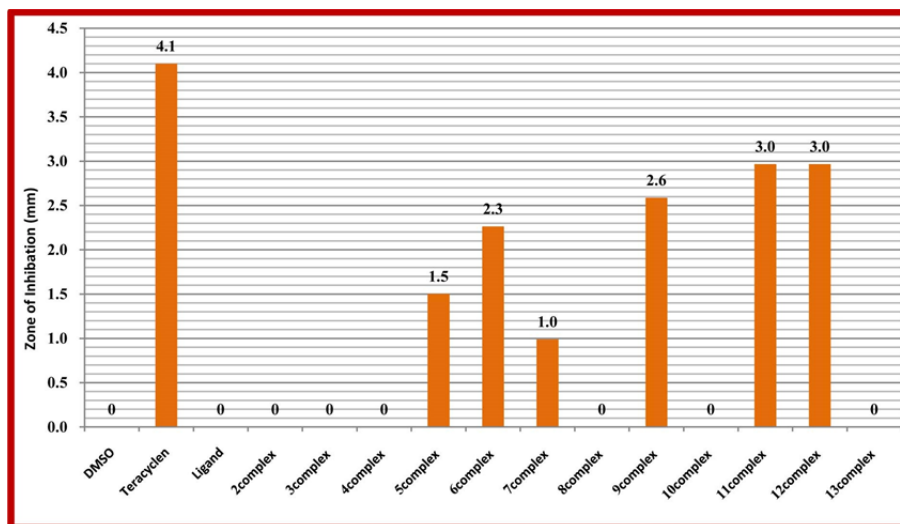

Fig. 6. Antibacterial activity of the ligand and its metal complexes against gram-negative bacterium (*E. coli*).

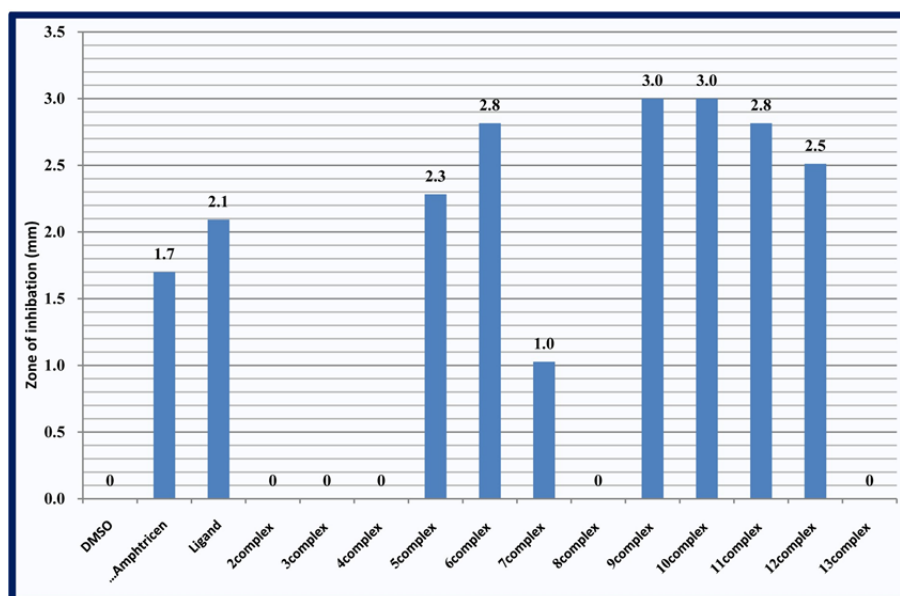

Fig. 7. Antifungal activity of the ligand and its metal complexes against Fungus (*Aspergillusniger*).

SUMMARY

The chromium(III), manganese(II), iron(III), cobalt(II), nickel(II), copper(II), ruthenium(III) and zirconyl(II) complexes of N^1,N^2 -bis(3-((3-hydroxynaphthalen-2-yl)methyleneamino)propyl) phthalamide has been synthesized and characterized by elemental and thermal analyses as well as spectroscopic techniques. The analyses data showed that, the ligand behaves as a neutral tridentate, neutral hexadentate, dibasic tridentate or dibasic hexadentate ligand bonded to the metal ion/ions through azomethine nitrogen atoms, protonated or deprotonated hydroxyl groups and protonated or deprotonated amine groups. The metal complexes have a distorted octahedral, square planer or octahedral geometry. The ESR spectra of solid copper(II) complexes 2, 5,

and 6 show $g_{\parallel} > g_{\perp} > g_c(2.0023)$, indicating octahedral structure with significant covalent bond character. The biological studies showed that the ligand biologically is active against Gram negative bacterium (*Escherichia coli*), and its metal complexes have mild activity in comparing with Standard antibacterial drug (Tetracycline) but has strongly biological activity against Fungus (*Aspergillus niger*) in comparing with Standard antifungal drug (Amphotericin B).

REFERENCES

1. You, Z.-L.; Shi, D.-H.; Xu, C.; Zhang, Q.; Zhu, H.-L. *European Journal of Medicinal Chemistry*. 2008, 43, 862.
2. Bekhit, A. A.; El-Sayed, O. A.; Al-Allaf, T. A. K.; AboulEnein, H. Y.; Kunhi, M.; Pulicat, S. M.; Al-Hussain, K.; Al-Khodairy, F. Arif, J. *Eur. J. Med. Chem.* 2004, 39, 499.
3. Golcu, A.; Tumer, M.; Demirelli, H.; Wheatley, R. A. *Inorg. Chim. Acta*. 2005, 35, 8.
4. Singh, K.; Barwa, M. S.; Tyagi, P. *Eur. J. Med. Chem.* 2006, 41, 147.
5. Chakraborty, J.; Patel, R. N. *J. Indian Chem. Soc.* 1996, 73, 191.
6. Bu, X. H.; Du, M.; Zhang, L.; Song, X. B.; Zhang, R. H. *Inorg. Chim. Acta*, 2000, 308, 143.
7. Carraquilleo, J. A.; White, J. D.; Paik, C. H.; Raubitschek, A. N.; Rotman, M.; Brechbiel, M.; Gansow, C. A.; Top, L. E.; Peretesis, P.; Reynolds, J. C.; Nelson, D. L.; Waldmann, T. A. *J. Nucl. Med.* 1999, 40, 268.
8. Guo, Z.; Sadler, P. J. *Angew. Chem. Int. Ed.* 1999, 38, 1512.
9. Mortellaro, M. A.; Nocera, D. G. *J. Am. Chem. Soc.*, 1996, 118, 7414.
10. Zhang, S.; Wu, K.; Sherry, A. D. *Angew. Chem. Int. Ed.*, 1999, 38, 3192.
11. Caravan, P.; Ellison, J. J.; McMurry, T. J.; Lauffer, R. B. *Chem. Rev.* 1999, 99, 2293.
12. Garnovskii, A. D.; Vasilchenko, I. S.; Garnovskii, D. A.; Kharisov, B. I. *J. Coord. Chem.* 2009, 62, 151.
13. G. Svehla "Vogel's textbook of macro and semi micro Quantitative inorganic analysis" fifth Ed. Longman Inc. New York 1979.
14. Hoffman, R. V. "Organic chemistry an intermediate text" 2nd Ed. John Wiley & Sons, Inc., Hoboken, New Jersey 2004, pp 188.
15. Offiong, E. O.; Martelli, S.; Farm, I. L. 1994, 49, 513.
16. Collee, J. G.; Duguid, J. P.; Farser, A. G.; Marmion, B. D. (editors) "Practical Medical Microbiology" New York, Churchill Livingstone (1989).
17. Wu, L.; Qiu, G.; Teng, H.; Zhu, Q.; Liang, S.; Hu, X. *Inorg. Chim. Acta*, 2007, 360, 3069.
18. Puralimardan, O.; Chamayou, A.-C.; Janiak, C.; Monfared, H. H. *Inorg. Chim. Acta*, 2007, 360, 1599.
19. El-Tabl, A. S.; El-Saied, F. A.; Al-Hakimi, A. N. *Trans. Met. Chem.* 2007, 32, 689.
20. Maurya, M. R.; Agarwal, S.; Bader, C.; Rehder, D. *Eur. J. Inorg. Chem.*, 2005, 147.
21. Glu, M. K.; Ispir, E.; Glu, N. K.; Serin, S. *Dyes and Pigments*, 2008, 77, 75.
22. Han, H. O.; Kim, S. H.; Kim, K. H.; Hur, G. C.; Yim, H.J.; Chung, H. K.; Woo, S. H.; Koo, K. D.; Lee, C. S.; Koh, J. S.; Kim, G. T. *Bioorg. Med. Chem. Lett.* 2007, 17, 937.
23. Geaey, W. J. *Coord. Chem. Rev.* 1971, 7, 81.
24. El-Tabl, A. S.; Issa, R. M.; Morsi, M. A. *Trans. Met. Chem.* 2004, 29, 543.
25. El-Tabl, A. S. *Trans. Met. Chem.* 1997, 22, 400.
26. Tas, E.; Ulusoy, M.; Guler, M.; Yilmaz, L. *Trans. Met. Chem.* 2004, 29, 180.
27. El-Behery, M.; El-Twigry, H. *Spectrochim. Acta Part A*, 2007, 66, 28.
28. Nakatamoto, K. "Infrared Spectra of Inorganic and Coordination Compounds" 2nd Edit., Wiley Inc. New York, 1967.
29. El-Wahab, Z. H. A.; Mashaly, M. M.; Salman, A. A.; El-Shetary, B. A.; Faheim, A. A. *Spectrochim. Acta Part A*, 2004, 60, 2861.
30. El-Tabl, A. S.; Imam, S. M. *Trans. Met. Chem.* 1997, 22, 259.
31. El-Tabl, A. S. *J. Chem. Res.(s)*, 2002, 529.
32. Cukuravali, A.; Yilmaz, I.; Kirbag, S. *Trans. Met. Chem.*, 2006, 31, 207.
33. Chen, C.-Y.; Chen, Q.-Z.; Wang, X.-F.; Liu, M.-S.; Chen, Y. F. *Trans. Met. Chem.* 2009, 34, 757.
34. Tatwawadi, S. V.; Singh, A. P.; Narang, K. K. *J. Sci. Res. Banaras Hindu Univ.*, 1980, 3, 143.
35. Shauib, N. M.; Elassar, A.-Z. A.; El-Dissouky, A. *Spectrochim. Acta Part A*, 2006, 63, 714.
36. Lever, A. B. P. "Inorganic Electronic Spectroscopy" 2nd edn, Elsevier, Amsterdam, 1984.
37. El-Tabl, A. S.; El-Enein, S. A. *J. Coord. Chem.* 2004, 57, 281.

38. Gudasi, K. B.; Patil, M. S.; Vadavi, R. S.; Shenoy, R. V.; Patil, S. A.; Nethaji, M. *Trans. Met. Chem.* 2006, 31, 580.
39. Thakkar, N. V.; Bootwala, S. Z. *Indian J. Chem.* 1995, 34A, 370.
40. El-Boraey, H. A.; El-Tabl, A. S. *Polish J. Chem.* 2003, 77, 1759.
41. Parihari, R. K.; Patel, R. K.; Patel, R. N. *J. Ind. Chem. Soc.* 2000, 77, 339.
42. Singh, N. K. *Trans. Met. Chem.* 2001, 26, 487. 43. Blinc, R.; Hadzi, D. *J. Chem. Soc.* 1958, 4536.
44. Zhang, S. W.; Liao, D. Z.; Jiang, Z. H.; Wang, G. L. *Trans. Met. Chem.* 1996, 21, 166.
45. Nehru, K.; Athappan, P.; Rajagopal, G. *Trans. Met. Chem.* 2001, 26, 652.
46. El-Tabl, A. S.; Issa, R. M.; Morsi, M. A. *Trans. Met. Chem.* 2004, 29, 543.
47. Motaleb, A. E.; Ramadan, M.; Sawodny, W.; Baradie, H. F. E.; Gaber, M. *Trans. Met. Chem.* 1997, 22, 211.
48. Nag, J. K.; Pal, S.; Sinha, C. *Trans. Met. Chem.* 2005, 30, 523.
49. Singh, M. K.; Kar, N. K.; Lai, R. A.; Asthana, M. J. *Coord. Chem.* 2009, 62, 2893.
50. Murukan, B.; Mohanan, K. *Trans. Met. Chem.* 2006, 31, 441.
51. El-Tabl, A. S.; Ayad, M. I. *Synth. React. Inorg. Met.-Org. Chem.* 2003, 33, 369.
52. Chandra, S.; Kamar, U. *Spectrochim. Acta, Part A*, 2005, 61, 219.
53. Patel, R. N.; Singh, N.; Gundla, V. L. N. *Polyhedron*, 2006, 25, 3312.
54. Kivelson, D.; Neiman, R. J. *Chem. Phys.* 1961, 35, 149.
55. Ray, R. K. *Inorg. Chem. Acta*, 1990, 174, 257.
56. El-Tabl, A. S. *Bull. Korean Chem. Soc.* 2004, 25, 1.
57. Mao, Z. W.; Yu, K. B.; Chen, D.; Han, S. Y.; Sui, Y. X.; Tang, W. X. *Inorg. Chem.* 1993, 32, 3104.
58. Symons, M. C. R. "Chemical and Biochemical Aspects of Electron Spin Resonance" Van Nostrand Reinholds Wokingham. 1979.
59. Natarajan, C.; Shanth, P.; Athappan, P.; Murugesan, R. *Trans. Met. Chem.* 1992, 17, 39.
60. Berrand, J. A.; Black, T. D.; Eller, P. G.; Helm, F. T.; Mahmood, R. *Inorg. Chem.* 1976, 15, 2965.
61. El-Wahab, Z. H. A.; Mashaly, M. M.; Salman, A. A.; ElShetary, B. A.; Fahei, A. A. *Spectrochim. Acta Part A*, 2004, 60, 2861.
62. Sengupta, S. K.; Pandey, O. P.; Srivastava, B. K.; Sharma, V. K. *Trans. Met. Chem.* 1998, 23, 349.
63. Glu, M. K.; Ispir, E.; Glu, N. K.; Glu, S. T.; Serin, S. *Trans. Met. Chem.* 2005, 30, 765.
64. Glu, M. K.; Gdelen, M. M. D.; Glu, S. T. *Trans. Met. Chem.* 2006, 31, 382.

IDENTIFICATION LOCAL MATTER TYPICAL SOUTH SUMATRA TO DEVELOP MODEL OF LEARNING BASED CONTRUCTIVISM FOR ENVIRONMENT LITERACY ON JUNIOR HIGH SCHOOL STUDENT IN INDONESIA

Oleh:

Meilinda*), Khoiron Nazip*), Ermayanti *) Ekapty Tyas Pradietha*), Rahmi Adila Putri*), Heni Indri Yastuti *)
*) Prodi Pendidikan Biologi fkip unsri
Address: Jl raya Palembang-Prabumulih Km 35 Indralaya-Ogan Ilir Sumsel-Indralaya
Meilinda.unsri@gmail.com

The main purpose of this research is to produce a prototype model of learning based typical local materials from South Sumatra to develop student environment literacy on junior high school in Indonesia. The purpose of the first year of the research one is identifying the material locally which are local wisdom, potential local and typical local problems of South Sumatra which can be utilized for the development students environment literacy model of learning which was done. Sampled area in this research is based on topography and demography divided into three district namely municipality Palembang represent urban areas, regency muara enim represent mountainous regions and regent Ogan Ilir represent of coastal marshes and transition. The result showed that on each sampled district for many local materials that could be used in learning biology especially to form characters environment literacy. Local content in the form of local wisdom are Tunggu Tubang, Lebak Lebung, Siring System. Being locally potential are productive forest area, waterfalls Curug, Swamp forest, River, Musi River and other tributaries, Pundi forest wood, Kemaro island as well as the coal mining, petroleum. Local wisdom and local potential can be utilized for learning on learning topics (Interaction between living organisms, pollution, Global warming, Increasing population, technology products) which relate to develop environmental literacy.

Keywords: local Materials, South Sumatra. The Learning Model, Environment Literacy;

Education environment since 1991 been entered curriculum all education level in Indonesia. The aim is to raise awareness of and passion for the environment and to learners having attitude care and not harm the environment (Nurjhani, 2003). The entry of the living environment in education, obligatory national curriculum becomes an alternative of the most rational for the success of the management of the environment and also become important means in producing human resources that can carry out the principle of sustainable development (Rowe, D., 2002; Martin *et al.*, 2006; Trevor, D., 2009; Trevor, D., 2010).

After 22 years, teaching material of environmental education applied in the study should have produced a real manifestation of attitudes and behaviour of environmentally conscious society (Adisensjaya, Y.H., 2009). But based on the research universities Adelaide (Corey J.A., 2010), Indonesia, including in four big countries most contribute to the environmental damage after Brazil, United States and China. Seven an indicator used in the research is deforestation, the use of chemical fertilizers, water pollution, carbon emissions, catching fish, and the threat of species of plants and animals, as well as transition land green to commercial land such as mall, or the center of trade and also an estate. Above an indication of the fact that the purpose of education environment haven't completely achieved. Yet to achieve educational objectives on the environment because the application of environmental education at all levels of education, ranging from elementary school SMP, SMA even in college has undergone disorientation. Likewise can be seen from learning and the process of material substance. On the substance of material ranging from elementary, junior high school and even in college, the material being taught more reflect the substance of the material science material substance yet ecological environment that is becoming a core staple on environmental education, even though substantially between ecology and environmental sciences is very different. The difference lies in viewpoints where ecology looked not human being out system nature contrarily science to a human environment viewed as inevitably a part of a system of nature. As the impact, strategy implementation of learning which used teacher or lecturer in teaching also be improper especially when viewed as achieving educational objective environmental oriented to development side affective learners psychomotor and learners form of attitude concern of the environmental experiencing shift into just a source of information cognitive form of knowledge only (Martin *et al.*, 2006; Adisensjaya, Y.H., 2009; Leksono *et al.*, 2012).

According to some studies, cognitive information conveyed to students anything separated from the environmental condition students who lived and do not touch the aspect of mental students actively in fact of

learning environment dna-based local matter is a recommendation on the agenda of 21 (Joseph et al. , 2007; Adisendjaja, 2009; Leksono et al. , 2012, Burn d.p. et al. 2009), the impact of all of these things is learning biology of the environment only limited to only hapalan only and does not provide any change in the attitude of students. Attitude affected by three things: knowledge (cognition) fondness (afeksi) and intention to commit (Conation). Knowledge affect conception.A conception of different, with the concept of if the concept is regarded as a collection of systematic knowledge that which is constituted or notion that are meaningful and agreed upon between scientists, then conception often regarded as' in a receptive manner a konsep' that is spatially subjective (Rustaman and Widodo, 1997). Other view expressed by pratt (1992) quoted Devlin (2006): one-twelve that conception is the specific signification given to a phenomenon and further show a response someone in represent and apprehends a phenomenon and learn according to konstruktivis is change conception (conceptual change).

Based on the above issues, it needs to be developed based on the constructivist model of learning biology with local materials typical of South Sumatra with the aim of cultivating the attitude of care environment (Environmental Literacy) especially in the junior high school students because the students of junior high school have the subjects of biology and research results Hess and Torney (1967) found that childhood is an important period for the development of the concept of self and sensitivity to be responsible citizens. Research also shows that after graduated from high school just get knowledge that is spatially fragmentation (Adisendjaja y.h. 2009).

Formulation of the Problem

Based on the description above, the outline of the research problem is how is the development of models of biological learning and local materials typical of South Sumatra which can Foster Literacy in students Enviroment.

Research Method

This research is development research, therefore the approach used also follow turnarounds development Research (Borg&Gall,1989) consisting of ten steps: 1) needs analysis and the study of literature; 2) product planning; 3) development of a prototype product; 4 limited Testing); 5 major product Revisions); 6) field testing; 7 Product Improvements); 8) Trial Court; 9) Revision of Final Products; and 10) dissemination and implementation. On this paper will be discussed at the third stage, namely the development of prototype products.

This research purposes to develop kind of classroom biology with local matherial typical south sumatra to grow enviromental literacy students. Research purposes are:

- a. Identify local material typical south sumatra form of the local wisdom, natural resources and problem of environment typical south sumatra.
- b. Develop blueprint model aimed to develop character enviroment literacy students

RESULTS AND FINDINGS

Model of Learning

According to Orr (1992, p.92), environmental literacy is the 'knowledge necessary to comprehend relatedness, and an attitude of care or stewardship [An environmentally literate] person would also have the practical competence required to act on the basis of knowledge and feeling'. UNESCO-UNEP (1989) suggests that 'environmental literacy' is the ultimate goal of environmental education. Orr (1992) argues that environmental literacy is primarily concerned with '*knowing, caring and practical competence*'. To this end, Orr (1992) argues that the environmentally literate person understands the dynamics of the environmental crisis which includes a thorough understanding of how people (and societies) have become so destructive.

Attitude is a term first used by Hebert Spencer (1862) which refers to a person's mental status (Azhar, 2013) in its development there are three frameworks of thought about the attitude that is defined as a form of feeling attitude favoring or impartial person on a certain object, both represented by Chave stating that attitude is a kind of readiness to react to an object with certain ways, readiness is a potential tendency to react in a certain way when the individual is exposed to a stimulus which requires the presence of response. The group third oriented scheme triadik stating that attitude is kontelasi components cognitive, affective and konatif who interact in the understanding; feel and behaves toward an object.Approach oriented to scheme triadik is known also -named tricompnent.Aspect attitude to be developed in this kind of classroom adheres to understand scheme triadik but

the placement third component konitif, affective and konatif this views on tripartite model namely attitude somebody already can be known from see one course of that response but description fully on attitudes of individuals should be obtained from seeing third response the full.

According to understand behaviouris, learning is a change in attitude (Behaviour Change) to make changes in the attitude of students required physical stimuli from the outside in the form of reinforcement (reinforcement), practice and external learner motivation are viewed passively while according to constructivism, learning is a change in the concept of (Conceptual Change). On the change of concept going on several stages the first stage called assimilation and the second stage is called accommodation. In order to assimilation and accommodation required terms such as dissatisfaction against the concept that there is a new concept, should be able to understand, rational and able to resolve the issue or phenomenon that is changing the concept of the ultimate goal of learning behaviour is changing the attitude of the students but the student how to change no further explanation other than just the conditioning of a learning environment while on approach to triadik scheme or third case involving attitude tricomponent i.e. cognitive, affective and konatif. Kontruktivisme focus on cognitive structure changes according to Posner (1982) there is a change in learning concepts, the concept of change there is assimilation and accommodation. Assimilation is the use of concepts that have existed for dealing with the phenomenon or new concepts while accommodation is a change concept radically because of incompatibility with the new phenomena encountered.

One of the constructivist learning model developed from constructivist theory of Vygotsy and Ausabel is Learning 5E Learning Cycle (root, 2005) model consists of 5 stages of Engagement, Exploration, Explanation, Elaboration and Evaluation (Bybee, 2009) while the conceptual changes in the models developed Joseph i. Stepan consists of 6 phases i.e. Commit to a position or learning outcomes, Exposé of limiting beliefs, beliefs, Confront Accomodate the concept, Extend the concept, Go beyond. On **first phase commit to a positions or outcome**, students invited to explore his mind own by sought response over a question or completion a problem. **On both phases expose belief students** with discussed and share ideas, reason, predictions against a problem with my one class or one group before they try to test the idea with a activity. **Thirth is confront student belive early ideas** they have experimented with conspiring to test conception early. Gregarious this experiment it might be working with tools and materials, collected data or consult on affairs. **At fourth phase acommodate the concept students accommodate views**, concept, and new skills in various ideas and situation. **At phase fifth extend the concept students** apply and make the relation between concept or new skills for the situation and a new idea. **The sixth phase of the Go beyond students** to apply these new ideas in their daily lives, from the analysis of the third theory above, developed a new learning model based on local materials to improve student literacy enviroment.

Identification Local Matter Typical South Sumatra

Learning science that uses a source of learning from local matter or environment around on a variety of studies (yuniatuti, 2013; mariantini, 2005; suratsih, 2010) can increase the competency basic science students in addition to that content of learning developed not from the environment distinctive about students led to students only gain knowledge technical course without impact of long-term with the students. This happens because the students who are at the age of smp are still facing the development of the ability of reflective and metakognitif and so students can not distinguish between information that is both factual and analyses the possibility because the students could not put different things reported in the same category (fleischer.S, 2010)

Typical local South Sumatra material identified in this research include local wisdom. Local wisdom is the agreement of local communities in the form of a series of values, rules and norms that are considered good and maintained hereditary. Local potentials identified in this research is artificial and natural resources in a region that is preserved as a local problem is all the negative aspects of human activities that have an impact on the physical environment include climate change, the loss of natural resources and pollution. The identification of local wisdom can be seen in table 1.

Table 1. Some Potential The Local Wisdom Typical South Sumatra To Build Character Enviroment Literacy

No	Potential wisdom	Location
1	Stage house	Most of the territory sumsel
2	Auction System of Lebak Lebung	OKI dan OI
3	Tekiang System	Semendo Territory
4	Tebat Mandian	Semendo

According to Sudjana and Ahmad (2009) learning resource requirements are: a) economical, economical low prices do not mean, can also Fund for procurement of learning resources is quite high but due to its utility for the long term so it could economically; b) practical and simple, c) easy to obtain; d) is flexible; e) components in accordance with the purpose, process and support the achievement of the learning objectives, can stir up motivation and interest in students learning. Those conditions can be pervaded by the stage. The stage is home construction field raised with traditional stories from surface soils with poles as penopangnya. Building stage is an adaptation, humans against environmental conditions e.g. when the tide water not come into the house. Building material is kayu derived from nature. Adaptation and of natural resources utilization examples human interaction with environment. This line with opinion Siswanto (2009) that the construction of a stage indirectly care environment is attitude may benefit in maintaining ecological to stay up earth ecosystems. It relates with the construction of buildings on the underside of the stage that is empty land, the water flow and keep water absorbs. Level responsife building in anticipation influence of temperate to tropical humid demonstrating ability building in interact in in its environment. The same advanced by Main (2013) that home traditional built and developed by considering environmental conditions around is the local wisdom because knowledge arif it obtained either from earlier generations or of his experiences relating to people and environment others and to finish problem. Interaction of human and its environment affecting the manner of construction house so house kept feel comfortable as the residence besides remain a harmonious with the environment. The same is expressed by Main (2013) that traditional home built and developed taking into account the environmental conditions surrounding the local wisdom as knowledge that is obtained either from arif the previous generation as well as from her experiences dealing with environmental and other community as well as to resolve the issue at hand. Human interaction and the environment affect the way the construction of the House so the House still felt comfortable as a residence in addition to remain harmonious with the surrounding environment. Such circumstances can be used as an object of discussion between teachers and students through a contextual approach, in particular regarding the adaptation and dependency towards nature which is a form of interaction of living things and the environment.

Ogan Ilir Regency, the Government issued local regulations (Perda) related fisheries in lebak lebung namely lebak lebung auction system. Lebak lebung auction system that is a way of getting the right system or an attempt to get a business license fishing for one year's time (Thys Michels, 2009). Lebak lebung is an area rich in nutrient elements that many aquatic plants are a source of natural fish fodder. Auction system of lebak lebung identified in this research is worthy as a learning resource. These can be seen from eligibility for compliance with the concept of the curriculum and learning materials science. According to the Department of national education science learning concept covers four main elements that: 1) attitude: curiosity about benda, natural phenomena, living beings, and relations for consequence to cause new problems that can be resolved through the correct procedure; 2) the process: procedure problem-solving through scientific method; 3) of: form of fakta prisp, theory and law; 4) application: the application of scientific method and concept science in daily life. Fourth concept learning science can be pervaded by bidding system lebak lebung good of solving a problem or kesesuaiannya with competence curriculum Yunior high school in Indonesia

Staple food semende society is rice and most district semende is sawah. In the provision of food usually people semende humped-up rice crop in tengkiang. Tengkiang is a typical the barn rice semende. Existence more in tengkiang closely related to food security. The purpose of making tengkiang semende is by society as a reserve supply of food when the lean season arrives. This conformable to law no 7 1996 about food which dictates that the government along the people responsible externalise his food security. The construction tengkiang nearly the same as breadbasket konstruksi rice in general is sustained by poles so as not to disturb water catchment area underneath. According to sartini (2004); custom basically capable in naturally and it is valued both, because those habits is a social repeated and had been increasing (reinforcement). Wisdom society semende tengkiang make effort in food security is a the local wisdom that shows the need humans against natural resources.

Tebat mandian is one of the utilization of water resources by society countryside muara calm by with menampungnya in two pool equipped with the circulation of water is good. Wisdom semende people in water resources management among others can be seen from making two pool shelter that serves as source of drinking water and toilet activity maintain clean environment around pond source of drinking water to prevent water from contaminated. Wisdom semende people in water resources management indicative of the human need for water and the interaction between humans and the environment in the utilization of natural resources.

CONCLUSION

Blue Print that development by this research are **first phase commit to a positions or outcome, On both phases expose belief students. Thirth is confront student belive early ideas** they have experimented with conspiring to test conception early.. **At fourth phase acommodate the concept students accommodate views,**

concept, and new skills in various ideas and situation. **At phase fifth extend the concept students** apply and make the relation between concept or new skills for the situation and a new idea. **The sixth phase of the Go beyond students** to apply these new ideas in their daily lives, from the analysis of the third theory above, developed a new learning model based on local materials to improve student literacy environment. **Some Potential The Local Wisdom Typical South Sumatra To Build Character Environment Literacy are** Stage house, Auction system of lebak Lebung, tekiang system and tebat mandian.

RECOMMENDATIONS

This result from the first year of research. Need more time to validity the model that developed. Thank you for DIKTI to funding this research in HIBAH BERSAING Year 2013.

REFERENCES

- Achyani, Rustaman, N.Y., Redjeki .S., Choessin, D.N., (2009). Model Penulisan Buku Ajar Biologi Sma Berwawasan Ekologi Dan Lokal untuk Meningkatkan Kepedulian Siswa Terhadap Lingkungan. *Jurnal BIOEDUKASI* 5(2), 15-35 UMMETRO
- Adisendjaja, Y.H., (2009). *Pembelajaran Pendidikan Lingkungan Hidup: Belajar Dari Pengalaman Dan Belajar Dari Alam*. Makalah Penelitian di Unduh dari Direktori Dosen UPI www.Upi.Edu/direktori/Dosen/Mipa/Pdf. Tanggal 2 Maret 2013
- Amini. R., (2010). Keterampilan Calon Guru Sekolah Dasar dalam Pembelajaran Pendidikan Lingkungan hidup Berbasis Outdoor. *Jurnal/Pendidikan Dasar/Nomor 13-April 2010/April 2010.pdf*.
- BSNP, (2006). *Standar Isi Untuk Satuan Pendidikan Sekolah Dasar dan Menengah*. Depdiknas:Jakarta
- Bonnett, M. (2007). Environmental Education and the Issue of Nature. *Journal of Curriculum Studies*, 39(6),
- Baharuddin dan Esa N. Wahyuni. 2010. *Teori Belajar dan Pembelajaran*. Yogyakarta: Ar-Ruzz Media.
- Cutter.A., Smith R., (2001). Gaunging Primary Scholl Teacher is Enviromenta Literacy an Issue of Priority. *Journal of Asia Pasific Education Review* Vol.(2) 45—60
- Chawla, L., & Flanders Cushing, D. (2007). Education for Strategic Environmental Behavior. *Journal of Environmental Education Research*, 13(4), 437-452.
- Carter .L., Dediwalage. R., (2010) . Globalisation and Science Education: The Case of Sustainability by the Bay. *Journal of Cultural Study of Science Education* (5):275–291
- Corey J. A., Bradshaw, Giam X., Navjot .S, Sodhi.,(2010). Evaluating the Relative Environmental Impact of Countries. *Jurnal of PLoS ONE* (5)5-e10440
- Depdiknas, 2003. *Mata Pelajaran Biologi untuk SMA dan MA..* Balitbang, Puskur,Departemen Pendidikan Nasional, Jakarta.
- Leksono S.M., Rustaman, N. (2012) Uji Coba Pengembangan Model Pembelajaran Konservasi Biodiversitas Berbasis Kearifan Lokal untuk Meningkatkan Literasi Biodiversitas bagi Calon Guru Biologi. *Proceeding Seminar Nasional Cakrawala Pembelajaran Berkualitas di Indonesia*.
- Martins, Mata M.A. Carlos A. V. Costa. (2006). Education for Sustainability: Challenges and Trends. *Journal of Clean Techn Environ Policy* Vol 8: 31–37
- Mueler, M.P. (2008). Educational Reflection on The “Ecology Crisis” Eco Justice, Environmentalism and sustainability. *Journal Science and Education. Vol 18 hal 1031-1056*
- Munck.M. 2007. Science Pedagogy, Teacher Attitudes, and Student Success. *Journal of Elementary Science Education*, Vol. 19, No. 2 (Fall 2007), pp. 13-24.
- Meilinda. Rustaman.N.Y. Widodo. A.(2009). Efektifitas E-Modul Interaktiv Berbasis Konstruktivisme untuk Meningkatkan Kompetensi Guru Biologi SLTP.*Jurnal Penelitian Pendidikan IPA*.3(2):153-163
- Meilinda.(2009).Teacher’s Pattern in Identifying of Genetic Material on E-Module interactive Based on Constructivism. *Proceeding of International Seminar about Technology Application on Learning Sciences. Education University of Yokya. Yokyakarta*.
- Meilinda, Tibrani,M.M., 2011 Identification Of Biology Science Teacher’s Misconception On Junior High School In Palembang. *Prosiding/Makalah Internasional ISBN: 979-979-9923294-0*. Bandung
- Nurjhani,(2003). Model Pembelajaran Tematik ‘Makanan Untuk Hidup’ Dengan Mengembangkan Kemampuan Bekerja Ilmiah Di Sekolah Dasar. *Jurnal Pendidikan UPI. No. 3*
- Nuyen, A. (2008). Ecological education: What resources are there in Confucian ethics? *Journal Environmental Education Research*, 14(2), 187-197.

- Nurwidodo. 2012. Peningkatan Kepekaan terhadap Masalah Lingkungan dan Pengaplikasiannya untuk Menyusun Rencana Penelitian melalui Penerapan Group Investigation (GI). *Proceeding Seminar Nasional Cakrawala Pembelajaran Berkualitas di Indonesia*.
- Oerke, B., Bogner F.X., (2010). Gender, Age and Subject Matter: Impact On Teachers' Ecological Values. *Journal Environmentalist (30):111–122*
- Penttinen. R, Minkkinen S. 2007. Technology and Pedagogy – How to Learn Technique. *J. Studies in Computational Intelligence (SCI) 62, 255–283*
- Perdan S, Azapagic A, Clift R (2000) Teaching sustainable development to engineering students. *International Journal Sustain Higher Education 1(3):267–279*
- Rowe D. (2002). Environmental Literacy And Sustainability As Core Requirements: Success Stories And Models. *Jurnal of Teaching Sustainability At Universitie (5) 39-45*
- Rebich S., Gautier C., (2005). Concept Mapping to Reveal Prior Knowledge and Conceptual Change in a Mock Summit Course on Global Climate Change. *Journal of Geoscience Education, v. 53, n. 4, p. 355-365*
- Suparno,P.(1997). *Filsafat Konstruktivism dalam Pendidikan*.Yogyakarta.Penerbit Kanisius
- Spiropoulou D., Antonakaki T., Kontaxaki S., Bouras S.,(2007). Primary Teachers' Literacy and Attitudes on Education for Sustainable Development. *Journal Science Education Technology Vol. 16:443–450*
- Sipos. Y. (2009). Non-Traditional Pedagogies In Advanced Education: Engaging Head, Hands & Heart For Environmental And Educational Benefit. S. Allen-Gil et al. (eds.), *Addressing Global Environmental Security Through Innovative Educational Curricula*, © Springer Science + Business Media B.V.
- Suratsih. (2010). Pengembangan Modul Pembelajaran Biologi Berpotensi Budaya Lokal
- Sellmann D. & Bogner F.X. (2012). Effects of a 1-day environmental education intervention on environmental attitudes and connectedness with nature. *Eur J Psychol Educ. DOI 10.1007/s10212-012-0155-0*

Trevors, J.T. & Saier, M.H.,(2010). Education for Humanity. *Jurnal Water Air Soil Pollution* 206:1–2

UNESCO (tanpa tahun). *UN decade for education for sustainable development*. diunduh 1 Maret 2013 dari <http://portal.unesco.org/education/en/ev.php>

Van, Berkel .R.V. (2000). Integrating The Environmental And Sustainable Development Agendas Into Minerals Education. *Jurnal of Clean Production* 8:413–423

Yustina. (2006). Hubungan Pengetahuan Lingkungan Dengan Persepsi, Sikap dan Minat Dalam Pengelolaan Lingkungan Hidup Pada Guru Sekolah Dasar Di Kota Pekanbaru. *Jurnal Biogenesis* Vol. 2(2):67-71, 2006

Yusuf. Y., Rhoma D.W., (2007). Transformasi Masyarakat Melalui Pendidikan Lingkungan Hidup (Kajian Perilaku Masyarakat Kampus Dan Kurikulum Pendidikan Lingkungan di Perguruan Tinggi Yogyakarta). *Jurnal Penelitian Bappeda Kota Yokyakarta* Volume 2. 2007

KO TE ARO WHAKAMURĪ KĪA ANGA WHAKAMUA. REFLECT ON THE PAST IN ORDER TO FORGE THE FUTURE.

Leeana HEREWĪNĪ

Roslyn BARTOSH

This paper is a critical reflection on our involvement and experience in Pāngarau Education (or Mathematics Education) in Aotearoa (New Zealand) which is how mathematics is constructed and taught through the medium of New Zealand's indigenous language, Māori. Pāngarau education has been described as contributing to and being firmly located within the overall context of Māori development which includes the maintenance and revitalisation of the Māori language (Christensen, 2002).

We have been actively involved in Pāngarau education for 15 years through our work as professional learning and development facilitators in schools throughout the country. Pāngarau education has undergone significant changes during this time. Some of the key highlights during the 15 years have been the focus given to mathematical literacies and the links to information and communication technologies. This paper examines some of these changes and highlights and proposes some ways for the continued growth and development of Pāngarau education in the future.

Keywords: Mathematics, reflection, language

ASRIN SU PROJESİ: KUZEY KIBRIS ORTAÖĞRETİM ÖĞRENCİLERİNDE SU TÜKETİMİNE VE ÇEVREYE YÖNELİK FARKINDALIK

THE WATER PROJECT OF THE CENTURY: AWARENESS OF THE STUDENTS ABOUT WATER CONSUMPTION AND ENVIRONMENT IN NORTH CYPRUS HIGH SCHOOLS

Aşkın KİRAZ

Yrd. Doç. Dr., Yakın Doğu Üniversitesi Atatürk Eğitim Fakültesi
askkiraz@yahoo.com

Altay FIRAT

Dr., Coğrafya Öğretmeni, Güzelyurt Türk Maarif Koleji
altayfiratus@yahoo.com

ÖZET: Çevre sorunları kapsamında karşılaşılan büyük tehlikelerden biri yeraltı ve yerüstü sularında görülen azalmadır. Son yıllarda nüfusun hızla artması, iklim şartlarının ve artan sanayileşmenin kısıtlı olan su kaynaklarını olumsuz şekilde etkilemesi nedeniyle yeryüzünde bir su kıtlığı sorunu baş göstermiştir. Kuzey Kıbrıs'ta çevre problemleriyle ve iklimle bağlantılı olarak belirginleşen su sıkıntısı için "Asrın Su Projesi" hazırlanmış ve çalışmalara başlanılmıştır. Ada'nın da içinde bulunduğu yerkürede ortaya çıkan çevre ve su problemlerine getirilen çözüm önerilerinden en önemlisi ve kalıcı olanı şüphesiz insanların eğitilmesidir. Bu çalışmada Kuzey Kıbrıs'ın batısında yer alan ve proje alanı olan Güzelyurt yöresinde ortaöğrenime devam eden öğrencilerin çevreye yönelik bilinçleri ile suyun önemine yönelik tutumlarının belirlenmesi hedeflenmiştir. Çalışma betimsel türde bir araştırmadır ve ilişkisel tarama deseniyle yürütülmüştür. Veriler "Çevreye Yönelik Bilgi ve Bilinç Ölçeği" ve "Su Tutum Ölçeği" ile elde edilmiştir. Sonuçlar istatistiksel olarak yordanmış, iki ölçek arasındaki korelasyon ve öğrencilerin demografik bilgileri ile ilişkilendirilmiştir.

Anahtar sözcükler: Asrın Su Projesi, Kuzey Kıbrıs, su tutumu, çevre bilinci.

ABSTRACT: One of the dangers met within environmental problems is the decrease in surface and ground waters. In the recent years, shortage of water has appeared because the population has increased rapidly and climate conditions and rising industrialization have had a negative effect on limited water sources. In Northern Cyprus, for the water problems which have arisen in relation with environmental problems and climate, "The Water Project of the Century" has been prepared and put into practice. The most important and lasting solution offer brought for the water and environmental problems which have appeared in the hemisphere where the Island is also in, is undoubtedly educating people. In this study, it is aimed to determine the attitudes of environmental consciousness and the importance of water of the students who attend high school education in Güzelyurt in the west of the island and where the project area is. This is a descriptive study and it has been designed with correlational survey model. The data has been gained with "The Scale of Environment Oriented Knowledge and Consciousness" and "Water Attitude Scale". The Results have been expected statistically and have been related with the correlation between two scales and students' demographic knowledge.

Key words: The Water Project of the Century, North Cyprus, water attitude, environmental consciousness.

GİRİŞ

Çevre, insanın sosyal, biyolojik ve kimyasal bütün faaliyetlerini sürdürdüğü bir ortamdır (Aydoğdu ve Gezer, 2009). Belirli bir dönemde direkt veya dolaylı bir şekilde şahsı etkileyen, onun maddi manevi gelişmesini ve yaşam şartlarını belirleyen biyolojik, coğrafik ve toplumsal olayların tamamına çevre denir. Çevre bugün doğal ekonomik ve kültürel değerlerin bütünü olarak algılanmakta ayrıca insanla birlikte bütün organik ve inorganik varlıklarla canlı varlıkların her çeşit eylem ve davranışını etkileyen fiziksel, kimyasal, biyolojik ve toplumsal nitelikteki unsurların bütünü olarak değerlendirilmektedir (Bozkurt, 2010). Çevre toprak, su ve hava küre şeklinde üç geniş kavramı ifade etmektedir. İnsanlar, bitkiler ve hayvanlar ile bunların yaşadıkları çevre ile olan ilişkilerini inceleyen bilim dalı ise Çevre Bilimi veya Ekoloji olarak adlandırılmaktadır (Özey, 2009).

Su, biyosfer için en gerekli maddelerin başında gelmektedir. Toplumsal yaşamda suyun yeri hiçbir madde ile ikame edilemez. Yaşamın, iklimin, havanın, toprağın, bitkilerin, canlı organizmaların fiziksel ve kimyasal özelliklerinin biçimlenmesinde suyun rolü oldukça büyüktür (Güney 2008). Su ile toprak, ülkelerin gelişme süreçlerinde birincil olarak başvurulan kaynaklar olma özelliklerine sahiptir (Tomanbay, 2008). Su, atmosfer döngüsü süreci içerisinde doğal dengenin sağlanmasında ve canlı yaşamının devamı için gerekli temel unsurların başında gelmektedir. Su, bu özelliği sayesinde hidrolojik, ekonomik, hukuk, politika ve biyoloji gibi çeşitli bilim dalları tarafından da incelenmektedir. Su sadece oksijen ve hidrojen kaynağı değildir. Bunun yanında canlıların temel yapı maddesi olup, insan kütleinin %60'ını, bitkinin %95'ini, tahılların %79'unu, mantarların %80'ini oluşturur. Yeryüzünün ise 2/3'si (363 milyon km²) sudur (Akman, Ketenoğlu, Kurt, Düzenli, Güney; 2012).

Yeryüzünde bulunan toplam su miktarı 1600000 x 103 km³'tür. Bunun 220000x103 km³'ü kimyasal olarak bağlı su, geriye kalan 1380.000x103 km³'ü ise serbest sudur. Toplam su miktarının %97'si tuzlu su olup bu miktar insanların kullanımı için uygun değildir. Karalardaki toplam tatlı su miktarı %3 olup bu miktarı yer altı suları, kar/buz, yüzey tatlı suları ve atmosferdeki su buharı oluşturmaktadır (Özdemir, 1997).

Su kaynakları son yüzyılda büyük problemlerle karşı karşıya kalmıştır. Su kıtlığı probleminin yanında su kalitesinin de hızla bozulmakta olması dünya genelinde bir alarm konusudur (WWAP, 2009). Bu sorunlar sadece ekolojik anlamın yanında, sosyal ve ekonomik açıdan domino etkisi yaparak pek çok soruna sebebiyet verdiklerinden oldukça önemlidirler (Brody, 1995). Özellikle içme ve kullanma suyu elde edilen su kaynakları, evsel ve endüstriyel özellikli atıklar, aşırı gübreleme, bilinçsiz kullanılan zirai mücadele ilaçları, aşırı nüfus artışı ve şehirleşmenin etkisi altındadır (UNEP, 1987; WWAP, 2006; 2009).

Çevre ve Su Eğitimi

Çevre eğitiminin amacı, insanların ekolojik çevrelerini ve bunun içerisindeki yerini kavramalarına, buna paralel olarak kişilerin insan toplumlarının dünyamızla nasıl uyum içerisinde yaşayabileceklerine ilişkin görüş geliştirmelerine, etkin ve sorumlu bir katılım için lüzum olan gerekli becerileri kazanmalarına yardım etmektir (Aydoğdu ve Gezer, 2009). Su eğitimi ise, insanlara su bilinci ve suyu dikkatli kullanma alışkanlığı kazandırmayı hedeflemektedir. Çevre ve su sorunlarının çözümünde "eğitim" önemli bir yer tutmaktadır. Su ve çevre problemlerinin çözümü için özellikle öğrenim çağındaki bireylerde bazı davranış değişikliklerinin sağlanması ve buna bağlı olarak bir farkındalığın gerçekleştirilmesi gerekmektedir. Çevre ve su eğitiminde hedef kitle sadece öğrenciler değil, tüm insanlardır. Fakat eğitimin amacına ulaşmasında bireylere küçük yaştan itibaren istedik yönde davranış kazandıran örgün eğitim sisteminin temel yapısı okullara büyük görevler düşmektedir.

Çevre eğitimi, çevre koruma ile ilgili bir eğitimidir. Çevre sorunları ile ilgilenme çevre eğitiminin çekirdeğini oluşturur. Bu süreç, birlikte yaşamın kuralları, çevrenin kuralları, yaşama alanlarının planlanması, yeni ekolojik görüş açısının ön plana alındığı bir eğitim sürecidir. Çevre eğitimi, çevre ile ilgili konuların çok özele indirgenmeden ve fazla bilgi bombardımanına tabi tutmadan yapılmasıdır. Kızıroğlu (2001), çevre eğitimi ile ilgili aşağıdaki yargılara varmıştır:

- Çevre eğitimi, bireyin ekolojik davranış biçimini şekillendirir,
- Çevre eğitimi, okulda öğrencilerden istenen doğal, sosyal ve yapay çevre ile olan davranış ilişkilerini kapsar,
- Çevre eğitimi, okulda sorunların çözümü için gerekli yeteneğin öğrenciye kazandırılmasına yardımcı olur, ilerde siyasi yaşama katılımını sağlar,
- Çevre eğitiminin interdisipliner düzeyde verilmesi gerekir,
- Çevre eğitimini öğrenci, aile, kitle iletişim organları, sivil toplum örgütleri, okul yönetimi ve öğretmenler birlikte çalışarak şekillendirmelidir.

Su Tutumu

Tutum, sosyal psikologlar tarafından kişilerin gözle görülmeyen kişi, nesne veya olaylara bağlı duygu, düşünce ve davranışlarını birleştiren eğilimleri olarak ifade edilmiştir (Aydm, 2007). Tutum sahibi olan birey olumlu veya olumsuz tepkileri gösterme eğilimine sahiptir. Dolayısıyla birey sahip olduğu düşünce ve davranışların olumlu ve olumsuzluğuna bakmadan zamanını düşünmekle, ilgilenmekle ve ilişkili konularla uğraşmakla geçirir (Tezbaşaran, 1997). Bireylerin su tüketimi ve su kullanımına yönelik tutumlarının olumlu yönde gelişmesi, suyun önemi, yaşam kaynağı olarak su, metabolizma ve su, küresel ısınma, yer altı ve yer üstü suları, sulardaki kirlenme ve azalma gibi konularda bilinçlendirilmeleri ve eğitilmeleri ile mümkündür. Auriault (1998) su eğitiminin amaçlarını aşağıdaki gibi belirtmiştir:

- Su kaynakları, kullanımı, kirliliği, korunması ve yönetimi konularında bilgi kazandırmak.
- Suyun tasarruflu kullanımı ve su kaynaklarının korunması üzerine tutum ve davranışlar kazandırmak.
- Su kaynaklarının korunması ve kirliliğin azaltılması üzerine kişisel ve toplumsal sorumluluk kazandırmak ve bireylerin katılımını sağlamak.

Çevre Bilinci

Fiziki ve beşeri çevrenin bozulması halinde birey ve birey topluluklarının büyük problemlerle karşılaşacağını bilmesi ve algılaması için her türlü eğitim imkanlarından yararlanarak onlara çevre bilincinin verilmesi gerekmektedir. Çevre bilincine erişmede en önemli şart ise kişinin sosyal davranışlarının temelden değişmesidir. Bu da ancak verilecek etkili ve kapsamlı bir çevre eğitimi ile mümkündür (Sipahioğlu, Yıldız ve Yılmaz; 2009).

Bilinç, çevre ile ilgili kararları, ilke ve yorumları kapsayan düşüncelerden ve bunların hayata aktarılması olan davranışlardan ve tüm bunlarla ilgili çeşitli duygulardan meydana gelir. Çevre bilinci, kişilerin geçmişi, bugünü ve geleceği aklından çıkarmadan hem kendine hem de doğaya saygılı olabilmesi demektir. Çevre bilincinin düşünsel, duygusal ve davranışsal boyutları mevcuttur (Türküm, 1998). Çevre bilincinin kazandırılmasında etkili olan faktörler aşağıda sunulmuştur.

- Kişilerde çevreye yönelik olumlu bir tutumun gelişmesini sağlayacak uygun ortam, uygun model ve uygulamalar sağlanmalıdır.
- Fikir, düşünce ve mesajlar; propaganda, dayatma ve dikte etme tarzında verilmeye çalışılmamalıdır. Yöntem olarak alternatifler sunarak, uygun yollar önererek bireylerin meseleyi anlamasını ve benimsemesini sağlamaya çalışılmalıdır.
- Süreç içinde uygun sıklıkta tekrar yapılması sağlanmalıdır.
- Bireylerin mümkün olduğu oranda doğayla iç içe olması sağlanmalıdır.
- Sadece teorik bilgiler ve mesajlarla kalmayıp, mesajlarda görselliğe önem verilmelidir.
- Çevre, çevre konusunda bilgilendirme, eğitim ve sorumluluk görevleri sadece kamu kurum ve kuruluşlarına yüklenmemeli, sosyal sorumluluk kapsamında özel sektörün de desteği olmalıdır.
- Uyarıcıların çok yönlü olması, güven ve inandırıcılığı artıracaktır (Türk, 2011).

Araştırmanın Amacı

Kıbrıs Adası, yarı kurak (Subtropikal) iklim kuşağının Akdeniz İklim Tipi içerisinde yer almaktadır. Bu özelliği ile, Kuzey Kıbrıs'ta yıllık yağış ortalaması 285mm ile 550mm arasında olup, en az yağış adanın batısındaki Güzelyurt Yöresine düşmektedir. Yörede yağış azlığı ve yer altı su aküferinin tarımda ve içme suyu temin etmede sürekli kullanılması, suların ve toprağın tuzlanmasına ve yer altı su aküferinin zayıflamasına ve dolayısı ile adanın en büyük yer altı su rezervine sahip olan yöresinde büyük su sıkıntısı yaşanmasına neden olmaktadır. Kuzey Kıbrıs'ta çevre problemleriyle ve iklimle bağlantılı olarak belirginleşen su sıkıntısı için "Asrın Su Projesi" hazırlanmış ve çalışmalara başlanılmıştır. Bu proje ile Kuzey Kıbrıs'a sulama ve içme suyu aktarılması hedeflenmiş ve deniz seviyesinden 250m derinliğinde askı borularla yıllık 75 milyon m³ su aktarımı yapılması amaçlanmıştır. Bu noktadan hareketle, bu araştırma, ada batısında bulunan Güzelyurt Yöresinde yaşayan ortaöğretim öğrencilerinin bu proje ile gelecek olan suyun çevre üzerindeki etkisine bağlı olarak, çevre bilinç düzeyleri, su tutumları ve bunun neticesinde çevre ve su farkındalıklarının ne düzeyde olduğunun tespit edilmesi amacı ile yapılmıştır. Araştırmanın genel amacı doğrultusunda belirlenen alt amaçları aşağıda verilmiştir:

- Öğrencilerin "Çevreye Yönelik Bilgi ve Bilinç Ölçeği" puanları ile "Su Tutum Ölçeği" puanları ne düzeydedir?
- Öğrencilerin "Çevreye Yönelik Bilgi ve Bilinç Ölçeği" puanları ve "Su Tutum Ölçeği" puanları cinsiyetlerine, okul türlerine, sınıflarına ve anne – baba eğitim durumlarına göre değişkenlik göstermekte midir?
- Öğrencilerin "Çevreye Yönelik Bilgi ve Bilinç Ölçeği" puanları ile "Su Tutum Ölçeği" puanları arasında anlamlı bir ilişki var mıdır?

YÖNTEM

Proje alanı olan Güzelyurt Bölgesinde yaşayan ve öğrenimlerine devam eden lise öğrencilerinin çevreye yönelik bilinçleri ile su tutumlarını inceleyen bu araştırmada korelasyonel tarama araştırma deseni kullanılmıştır. Karasar (2007), ilişkisel tarama modellerini iki veya daha çok sayıdaki değişken arasındaki değişimin varlığını ya da derecesini belirlemeyi amaçlayan araştırma modelleri olarak tanımlamaktadır.

Çalışmanın evreni Asrın Su Projesi alanı olan Güzelyurt Bölgesinde öğrenimlerine devam eden 9, 10, 11, 12. sınıf öğrencilerdir. Örneklem olarak 1 kolej, 1 meslek lisesi ve 1 düz lise seçilmiştir. Çalışmaya örneklem kapsamına dahil edilen Güzelyurt Türk Maarif Kolejinden 68 öğrenci, Güzelyurt Meslek Lisesinden 53 öğrenci ve Kurtuluş Lisesinden 78 öğrenci olmak üzere toplamda 199 öğrenci katılımcı olmuştur. Öğrencilerin 115'i kız, 84'ü erkektir. Çalışmaya katılan öğrencilerden 60'ı 9. sınıf, 36'sı 10. sınıf, 52'si 11. sınıf ve 51'i 12. sınıftır. Çalışmaya katılan örneklem grubunun anne eğitim durumu ilkököl mezunu 41 kişi, ortaokul mezunu 33 kişi, lise mezunu 90 kişi, üniversite mezunu 22 kişi, yüksek lisans – doktora mezunu 4 kişi ve okuryazar olmayan 9 kişidir. Çalışmaya katılan örneklem grubunun baba eğitim durumu ise ilkököl mezunu 43 kişi, ortaokul mezunu 38 kişi, lise mezunu 88 kişi, üniversite mezunu 21 kişi, yüksek lisans – doktora mezunu 9 kişidir.

Araştırmada veri toplama aracı olarak “Çevreye Yönelik Bilgi ve Bilinç Ölçeği” ve “Su Tutum Ölçeği” kullanılmıştır. Çevreye Yönelik Bilgi ve Bilinç Ölçeği Özpınar tarafından 2010 yılında geliştirilmiştir. Araştırmacı tarafından Kuzey Kıbrıs'a uyarlaması yapılan ölçek, geçerlik ve güvenilirlik hesaplamalarının ardından 26 madde ile uygulamaya konulmuştur. Arkış (1992) tarafından hazırlanan Su Tutum Ölçeği ise, 3lü likert tipinde 24 maddeden oluşmaktadır. Ölçeğin Cronbach alfa güvenirlik katsayısı .79 olarak belirtilmiştir. Araştırmacı tarafından tekrar değerlendirmeye alınan ölçeğin Cronbach alfa güvenirlik katsayısı .813 olarak belirlenmiştir. İki ölçekten oluşan anket formunun en başına araştırmacı tarafından hazırlanan demografik bilgiler kısmı eklenmiştir. Anket sorularına verilen cevapların analizleri SPSS 16.00 paket programı ile yapılmış ve değişkenler ile katılımcıların çevreye yönelik bilinçleri ve su tutumları istatistiksel olarak karşılaştırılmıştır. Veriler aritmetik ortalama, frekans-yüzde dağılımı, t-testi, anova ve Pearson Correlation analizi kullanılarak çözümlenmiştir.

BULGULAR VE TARTIŞMA

Bu bölümde çalışmanın verilerine ait istatistiksel analizler çalışmanın alt amaçları doğrultusunda sunulmuştur. Öncelikle katılımcıların cevapladıkları ölçeklerin genel bir değerlendirilmesi yapılmıştır. Değerlendirme sonuçları Tablo 1'de belirtilen aralıklar doğrultusunda değerlendirilerek Tablo 2'de sunulmuştur.

Tablo 1. Ölçek Aralıkları

	İyi	Orta	Kötü
Çevreye Yönelik Bilgi ve Bilinç Ölçeği	78-61	60-44	43-26
Su Tutum Ölçeği	72-57	56-41	40-24

26 maddeden oluşan Çevreye Yönelik Bilgi ve Bilinç Ölçeği'nden alınabilecek en düşük puan 26, en yüksek puan ise 78'dir. 24 maddelik Su Tutum Ölçeği'nde ise en düşük puan 24, en yüksek puan 72'dir. Düşük puan aynı zamanda düşük bilinç ve tutumu, yüksek puan ise yüksek bilinç ve tutumu göstermektedir.

Tablo 2. Ölçek Ortalama Puanları

	Mean	Std. Deviation	N
Çevreye Yönelik Bilgi ve Bilinç Ölçeği	57,9383	5,92718	199
Su Tutum Ölçeği	61,3272	7,20750	199

Analiz sonucunda Çevreye Yönelik Bilgi ve Bilinç Ölçeği'nin genel madde ortalaması 57,94 olarak bulunmuştur. Bu değer katılımcıların ölçeğe “orta” düzeyinde görüş bildirdiklerini göstermektedir. Su Tutum Ölçeği'nden alınan puanların ortalaması ise 61,33'tür. Bu puan “iyi” düzeyinde olup, Güzelyurt yöresinde yaşayan ve eğitim alan katılımcıların su tutumlarının, çevre bilinçlerinden daha olumlu ve yüksek olduğunu göstermektedir. Ünal'ın 2011 yılında yaptığı “İlköğretimde Sürdürülebilir Çevre Eğitiminde Suyun Yeri” adlı çalışmasında, çevre eğitiminin öncelikle ailede, bunu takip eden süreçte okullarda ve yaşam boyunca devam ettiği tespiti yapılmış, sürdürülebilir çevre eğitiminin önemli konusunun ise yaşam kaynağı olan su olduğu belirtilmiştir. Ayrıca çalışmada öğretmen ve öğrenciler için çevre eğitim programlarının değiştirilmesi veya düzenlenmesi gerektiği tespiti yapılmıştır. Şimşekli'nin (2004) “Çevre Bilincinin Geliştirilmesine Yönelik Çevre Eğitimi Etkinliklerine İlköğretim Okullarının Duyarlılığı” adlı çalışmasında, konuya dahil olan ilköğretim öğrencilerinin çevre konularına dikkatleri çekilmiş, bu konuda düşünceleri ve fikir üretmeleri sağlanmış fakat çevre eğitimi duyarlılıklarının istenilen düzeyde çıkmadığı saptanmıştır.

Tablo 3. Çevreye Yönelik Bilgi ve Bilinç Ölçeği ile Su Tutum Ölçeğinin Cinsiyete Göre Değerlendirilmesi

		N	\bar{X}	SS	F	Df	P
Çevre	Kız	115	55,08	5,89	.137	197	.375
	Erkek	84	55,84	5,98			

Su	Kız	115	62,96	6,60	6,170	197	.297
	Erkek	84	61,86	7,94			

Tablo 3, katılımcıların Çevreye Yönelik Bilgi ve Bilinç ile Su Tutum ölçeklerinden aldıkları puan ile cinsiyetleri arasındaki ilişkiyi göstermektedir. Tablolar incelendiğinde Çevre Bilinç ve Su Tutum ölçekleri sonuçlarının cinsiyetler üzerinde anlamlı bir fark yaratmadığı görülmektedir. Aslan, Sağır ve Cansaran (2008), “Çevre Tutum Ölçeği Uyarlanması ve İlköğretim Öğrencilerinin Çevre Tutumlarının Belirlenmesi” adlı çalışmada, kız ve erkek öğrencilerin çevreye yönelik tutumları arasında istatistiksel olarak anlamlı bir fark bulunmamıştır. Buna karşın Kaya, Akıllı ve Sezek (2009), “Lise Öğrencilerinin Çevreye Karşı Tutumlarının Cinsiyet Açısından İncelenmesi” adlı çalışmalarında, çevre tutumunda cinsiyetin kız öğrenciler lehine anlamlı olduğu tespitini yapmışlardır.

Tablo 4. Çevreye Yönelik Bilgi ve Bilinç Ölçeği ile Su Tutum Ölçeğinin Okul Türüne Göre Değerlendirilmesi

	Varyansın Kaynağı	Kareler Toplamı	Sd	Kareler Ortalaması	F	P	Anlamlı Fark
Çevre	Grupları Arası	210,317	2	105,158	3,055	0,049	Var*
	Gruplar içi	6745,712	196	34,417			2-3
	Toplam	6956,030	198				
Su	Grupları Arası	1992,434	2	996,217	23,544	0,00	Var*
	Gruplar içi	8293,284	196	42,312			1-3, 2-3
	Toplam	10285,718	198				

* p<.05,

- 1: Düz Lise , 2: Kolej , 3: Meslek Lisesi
- Çevre: X= '1' 55,30 , X= '2' 56,50 , X= '3' 53,92
- Su: X= '1' 64,55 , X= '2' 64,29 , X= '3' 57,26

Tablo 4, katılımcıların Çevreye Yönelik Bilgi ve Bilinç ile Su Tutum ölçeklerinden aldıkları puan ile okul türleri arasındaki bağlantıyı göstermektedir. Öğrencilerin her iki ölçekten aldıkları puanlar ile eğitim gördükleri okul türleri arasında anlamlı bir fark olduğu görülmektedir. Çevre Bilinç ölçeğine göre devlete ait olan ve sınavla seçilen kolej öğrencilerinin, meslek lisesi öğrencilerine göre daha yüksek bilgi ve bilinç düzeyine sahip oldukları tespit edilmiştir. Su Tutum ölçeği puanlarına göre düz lisenin, meslek lisesine ve kolejin, meslek lisesine göre manidar bir fark yarattığı görülmektedir. Bunun nedeninin kolej ve düz liselerde uygulanan ders programlarında çevreye yönelik temalara daha fazla ve kapsamlı yer verilmesi olduğu düşünülmektedir. Meslek liselerindeki ders programları ve ders sayıları, öğrencilerin seçtikleri mesleklerle ilgilidir. Yavuz (2006), “Proje Tabanlı Öğrenme Modelinin Kimya Eğitimi Öğrencilerinin Çevre Bilgisi İle Çevreye Karşı Tutumlarına Olan Etkisinin Değerlendirilmesi” adlı çalışmada, öğrencilerin hazır bulunuşluk ön test ve son test puanları arasında son test lehine anlamlı bir farklılık olduğunu saptamış ve bunun sonucu olarak çevre ile ilgili önceden alınan eğitimin yetersiz olduğu yönünde görüş bildirmiştir. Diğer bir çalışmada Dervişoğlu ve Kılıç (2012), eğitimde öğrencileri su tasarrufuna teşvik edecek eğitim etkinliklerine yönelik programların geliştirilebileceği ve öğretim programında bu konuda yapılabilecek düzenlemelere katkı sağlanabileceği yönünde önerilerde bulunmuştur.

Tablo 5. Çevreye Yönelik Bilgi ve Bilinç Ölçeği ile Su Tutum Ölçeği Puanlarının Sınıfa Göre Değerlendirilmesi

	Varyansın Kaynağı	Kareler Toplamı	df	Kareler Ortalaması	F	P	Anlamlı Fark
Çevre	Grupları Arası	78,254	3	26,084	0,739	0,529	Yok
	Gruplar içi	6877,776	195	35,270			
	Toplam	6956,030	198				
Su	Grupları Arası	682,607	3	227,535	4,620	0,003	Var*
	Gruplar içi	9603,110	195	49,246			1-4, 2-4, 3-4
	Toplam	10285,718	198				

* p<.05

- 1: 9.sınıf, 2: 10.sınıf, 3: 11.sınıf, 4: 12.sınıf
- Su: X= '1' 60,68 , X='2' 61,64 , X='3' 62,31 , X='4' 65,49

Tablo 5, katılımcıların Çevreye Yönelik Bilgi ve Bilinç ile Su Tutum ölçeklerinden aldıkları puan ile sınıfları arasındaki bağlantıyı göstermektedir. Sınıflara göre Çevre Yönelik Bilgi ve Bilinç ölçeği incelendiğinde anlamlı bir farkın olmadığı görülmekte fakat Su Tutum ölçeğinde 12. sınıfların diğer bütün sınıflara göre anlamlı bir fark yarattığı görülmektedir. Çevreye yönelik bilincin sınıflara göre değişiklik göstermemesinin sebebinin müfredatta çevreye yönelik özel bir dersin olmaması ve sosyal ve fen bilimleri derslerinde çevre temalarına

yeteri kadar yer verilmemesinin bir sonucu olduğu düşünülmektedir. Su tutumlarında anlamlı fark olmasının sebebinin ise, artan sınıf düzeyi ile birlikte bölgenin gerek yıllar öncesinden sahip olduğu küçük barajın, gerekse uygulamaya konulacak olan su projesinin bölge insanların su kullanımına yönelik bilinç ve duyarlılıklarını arttırmasından kaynaklandığı düşünülmektedir. Fırat, Sepetcioğlu ve Kiraz (2012), “Öğretmen Adaylarının Yenilenebilir Enerjiye İlişkin Tutumlarının İncelenmesi” başlıklı araştırmalarında öğretmen adaylarının sınıf düzeyleri ile çevre davranışları arasında artan sınıf düzeyi lehine anlamlı bir farklılık olduğunu bulmuşlar ve bu farklılığın ders programında yer alan çevre derslerinin artmasıyla doğru orantılı olduğunu ileri sürmüşlerdir. Cappellaro, Çoban, Akpınar, Yıldız ve Ergin (2011) “Yetişkinler İçin Yapılan Uygulamalı Çevre Eğitime Bir Örnek: Su Farkındalığı Örneği” adlı deneysel çalışmalarında, eğitim ile su kullanımına yönelik davranış ve tutumların olumlu yönde etkilendiği, çevre bilincinin anlamlı düzeyde geliştiği, ancak bu olumlu etkilerin sınırlı düzeyde kalıcı olduğu sonucuna varmışlardır.

Tablo 6. Çevreye Yönelik Bilgi ve Bilinç Ölçeği ile Su Tutum Ölçeği Puanlarının Anne Eğitim Durumuna Göre Değerlendirilmesi

	Varyansın Kaynağı	Kareler Toplamı	df	Kareler Ortalaması	F	P	Anlamlı Fark
Çevre	Grupları Arası	383,140	5	76,628	2,250	0,049	Var*
	Gruplar içi	6572,890	193	34,056			1-3, 2-3, 1-6,
	Toplam	6956,030	198				2-6
Su	Grupları Arası	425,907	5	85,181	1,667	0,144	Yok
	Gruplar içi	9859,811	193	51,087			
	Toplam	10285,718	198				

* p<.05

- 1: İlkokul , 2: Ortaokul , 3: Lise , 4: Yüksek Lisans Doktora , 5: Okuryazar değil , 6: Üniversite
- Çevre: X=’1’ 53,80 , X=’2’ 53,42 , X=’3’ 56,40 , X=’6’ 56,91

Tablo 6, katılımcıların Çevreye Yönelik Bilgi ve Bilinç ile Su Tutum ölçeklerinden aldıkları puan ile anne eğitim durumu arasındaki ilişkiyi göstermektedir. Çevreye ilişkin ölçekte anne mezuniyet durumunun ilkökul ile lise, ortaokul ile lise, ilkökul ile üniversite ve ortaokul ile üniversite mezunları arasında farklılaştığı görülmektedir. Artan eğitim seviyesinin çevreye yönelik bilinci de artırdığı düşünülmektedir. Su tutum ölçeğinden alınan puanlar, anne eğitim durumu ile su kullanımı arasında bir ilişki olmadığını göstermektedir. Annelerin eğitim düzeyleri, çocuklarının su kullanımı ve su tasarrufu davranışlarını etkilememektedir. Kabaş (2004), “Kadınların Çevre Sorunlarına İlişkin Bilgi Düzeyleri ve Çevre Eğitimi” adlı çalışmasında, deney gurubuna uyguladığı ön test ve son test sonuçlarında, son test lehine anlamlı bir farklılık elde edildiği ve eğitimle bayanların çevreye yönelik tutumlarında olumlu gelişmeler sağlanabileceği bulgusuna ulaşmıştır.

Tablo 7. Çevreye Yönelik Bilgi ve Bilinç Ölçeği ile Su Tutum Ölçeği Puanlarının Baba Eğitim Durumuna Göre Değerlendirilmesi

	Varyansın Kaynağı	Kareler T Oplamı	df	Kareler Ortalaması	F	P	Anlamlı Fark
Çevre	Grupları Arası	485,722	4	121,430	3,640	0,007	Var*
	Gruplar içi	6470,307	194	33,352			1-6, 2-3, 2-4,
	Toplam	6956,030	198				2-6
Su	Grupları Arası	601,981	4	150,495	3,014	0,019	Var*
	Gruplar içi	9683,737	194	49,916			2-3, 2-4, 2-6
	Toplam	10285,718	198				

* p<.05

- 1: İlkokul , 2: Ortaokul , 3: Lise , 4: Yüksek Lisans Doktora , 5: Okuryazar değil , 6: Üniversite
- Çevre: X=’1’ 54,60 , X=’2’ 52,82 , X=’3’ 56,15 , X=’4’ 57,33 , X=’6’ 57,81
- Su: X=’2’ 59,08 , X=’3’ 63,40 , X=’4’ 63,11 , X=’6’ 64,48

Tablo 7, katılımcıların Çevreye Yönelik Bilgi ve Bilinç ile Su Tutum ölçeklerinden aldıkları puan ile baba eğitim durumu arasındaki ilişkiyi göstermektedir. Çevreye yönelik ölçekte ilkökul ve üniversite arasında üniversite lehine, ortaokul ile lise arasında lise lehine, ortaokul ile yüksek lisans-doktora arasında yüksek lisans-doktora lehine ve ortaokul ile üniversite arasında üniversite lehine anlamlı bir farkın olduğu söylenebilir. Su Tutum ölçeğinde ise ortaokul ile lise arasında lise lehine, ortaokul ile yüksek lisans-doktora arasında yüksek lisans-doktora lehine ve ortaokul ile üniversite arasında üniversite lehine anlamlı bir farkın olduğu görülmektedir. Babaların eğitim seviyesinin artmasıyla, çocukların suya yönelik olumlu davranışlarının da arttığı görülmektedir. Bunun yanında Güzelyurt yöresine gelecek olan suyun babaların eğitim seviyesi etkeniyle birlikte suya yönelik duyarlılıklarını ve buna paralel olarak su tutumlarını da yükselttiği söylenebilir. Ayrıca bu sonuçlar, babaların çocuklarının eğitiminde etkili bir yere sahip olduğunu düşündürmektedir. Köse (2010),

“Lise Öğrencilerinin Çevreye Yönelik Tutumlarına Etki Eden Faktörler” adlı çalışmasında, anne-babaların öğrenim düzeyinin çevre tutumu üzerinde anlamlı bir etkisinin olmadığını ancak anne-baba öğrenim düzeylerinin arttıkça öğrencilerin çevreye karşı tutumunda iyileşme olduğu tespitini yapmıştır. Kızılaslan ve Kızılaslan (2005) “Çevre Konularında Kırsal Halkın Bilinç Düzeyi ve Davranışları” adlı çalışmalarında, araştırma bölgesinde çevre bilincinin yeterli olmadığı, okul programlarından başlamak üzere yaygın eğitim kapsamında da çevre eğitiminin alınması gerektirdiği sonucuna varmışlardır.

Tablo 8. Öğrencilerin Çevreye Yönelik Bilgi ve Bilinç Ölçeği Puanları ile Su Tutum Ölçeği Puanları Arasındaki İlişki

Correlations		Çevre	Su
Çevre	Pearson Correlation (r)	1	,391**
	Sig. (2-tailed)		,000
	N	199	199
Su	Pearson Correlation (r)	,391**	1
	Sig. (2-tailed)	,000	
	N	199	199

** Correlation is significant at the 0.01 level (2-tailed).

Tablo 8’de öğrencilerin “Çevreye Yönelik Bilgi ve Bilinç Ölçeği” puanları ile “Su Tutum Ölçeği” puanları arasındaki ilişkiye bakılmıştır. Tablodan görüldüğü gibi öğrencilerin çevreye yönelik bilgi ve bilinç düzeyleri ile su tutumları arasında pozitif yönde bir ilişki vardır. Öğrencilerin çevreye yönelik bilinçleri arttıkça, su tüketimi ve suyun önemine yönelik tutumlarının da arttığı görülmektedir.

SONUÇ VE ÖNERİLER

Bu araştırma, Ada batısında bulunan Güzelyurt yöresinde yaşayan, Güzelyurt Türk Maarif Koleji, Güzelyurt Kurtuluş Lisesi ve Güzelyurt Meslek Liselerindeki 9, 10, 11. ve 12. sınıflarında eğitim alan ortaöğretim öğrencilerinin, Asrın Su Projesi bölgesinde yaşama ve eğitim alma sebebi ile çevre bilinç düzeyleri, su tutumları ve buna bağlı olarak çevre ve su farkındalık düzeylerinin tespit edilmesi amacı ile yapılmıştır. Çalışmada büyük su projesi ile tanışan ve proje öncesi küçük bir baraj bölgesi olarak kullanılan yörede yaşayan öğrencilerin çevre ve su davranışları cinsiyet, okul türü, sınıf ve anne-baba eğitim düzeyi değişkenleri paralelinde incelenmiştir.

Araştırma sonucunda katılımcılar Çevreye Yönelik Bilgi ve Bilinç Ölçeğine “orta” düzeyinde görüş bildirmişlerdir (genel madde ortalaması 57,94). Su Tutum Ölçeği ise “iyi” düzeyinde yanıtlanmıştır (genel madde ortalaması 61,33). Bu puan Güzelyurt Bölgesinde yaşayan ve eğitim alan katılımcıların su tutumlarının, çevre bilinçlerinden daha olumlu ve yüksek olduğunu göstermektedir.

Katılımcıların Çevreye Yönelik Bilgi ve Bilinç Ölçeği ile Su Tutum ölçeklerinden aldıkları puan ile cinsiyetler arasındaki ilişkiye bakıldığında anlamlı bir farkın olmadığı görülmektedir. Kız ve erkek öğrencilerin çevre ve su davranışlarının eşit düzeyde olduğu saptanmıştır.

Katılımcıların her iki ölçekten aldıkları puan ile eğitim aldıkları okul türleri arasındaki ilişki incelenmiştir. Bulgular değerlendirildiğinde öğrencilerin gerek çevre, gerekse su davranışlarının okul türüne göre anlamlı bir şekilde değişkenlik gösterdiği, kolej ve düz lisenin meslek liselerine göre daha olumlu sonuçlar verdiği saptanmıştır. Öğrencilerin Çevre Bilgi ve Bilinç Ölçeği ortalama puanları, düz lise: 55.30, kolej: 56.50, meslek lisesi: 53.92 ve Su Tutum Ölçeği ortalama puanları ise düz lise: 64.55, kolej: 64.29 ve meslek lisesi: 57.26 şeklinde hesaplanmıştır. Genel olarak kolej ve düz lisede okuyan öğrencilerin ortalamalarının yüksek olduğu görülmektedir.

Araştırmada yer alan ve 9, 10, 11 ve 12. sınıfta öğrenim gören öğrencilerin Çevreye Yönelik Bilgi ve Bilinç Ölçeği ile Su Tutum ölçeklerinden aldıkları puanlar ile sınıfları arasındaki ilişki değerlendirilmiştir. Sınıflara göre çevreye yönelik davranışlarda anlamlı bir farkın olmadığı anlaşılmıştır. Su projesi bölgesinde uygulanan Su Tutum Ölçeği sonuçlarında artan sınıf düzeyine göre ortalamaların yükseldiği (9. sınıflarda 60.68, 10. sınıflarda 61.64, 11. sınıflarda 62.31 ve 12. sınıflarda 65.49) ve 12. sınıfların diğer bütün sınıflara nazaran anlamlı fark yarattığı bulunmuştur.

Katılımcıların Çevreye Yönelik Bilgi ve Bilinç ile Su Tutum ölçeklerinden aldıkları puan ile annenin eğitim durumu arasındaki ilişki incelenmiştir. Annelerin eğitim seviyeleri arttıkça, çocukların çevre bilinçlerinin de anlamlı bir şekilde yükseldiği, fakat anne eğitim durumu ile su davranışları arasında manidar bir ilişki olmadığı saptanmıştır.

Katılımcıların Çevreye Yönelik Bilgi ve Bilinç ile Su Tutum ölçeklerinden aldıkları puan ile babanın eğitim durumu arasındaki ilişkiye bakıldığında artan eğitim seviyelerinin her iki ölçekte de anlamlı farklar yarattığı görülmüştür. Çevreye Yönelik Bilgi ve Bilinç ölçeğinde baba eğitim durumu değişkeni kapsamında üniversitenin ilk ve ortaokula, lise ve lisanüstü eğitim seviyesinin ortaokula; Su Tutum Ölçeğinde ise lise, üniversite ve lisanüstü eğitimin ortaokula baskın olduğu görülmüştür.

Öğrencilerin “Çevreye Yönelik Bilgi ve Bilinç Ölçeği” puanları ile “Su Tutum Ölçeği” puanları arasındaki ilişkiye bakılmış, aralarında pozitif bir korelasyon olduğu belirlenmiştir. Bu korelasyonla öğrencilerin çevreye yönelik bilinçlerinin artmasıyla, su tüketimi ve suyun önemine yönelik tutumlarının da arttığı görülmüştür..

Araştırma sonuçları genel olarak incelendiğinde katılımcıların su davranışlarının, çevre davranışlarından daha olumlu ve yüksek bilinçte olduğu görülmüştür. Bu durumun, Güzelyurt yöresinde hem tarım, hem kullanma ve hem de içme suyuna olan ihtiyaçtan ve bu alanlarda yaşanan ve yaşanacak olan sorunların katılımcılarda yarattığı endişeden kaynaklandığı düşünülmektedir. Bu etkiler ile Türkiye’den gelecek olan suyun önemi, halkın konuya olan duyarlılık seviyelerini artırmış ve suya karşı olan tutumlarının yükselmesine neden olmuştur. Bu bilgiler doğrultusunda Yöredeki yerel yönetimden sorumlu olan belediye ve kaymakamlığın gerekli planlama çalışmalarını bitirmiş olmaları, yörede yer alan okullarda görevli eğitimcilerin öğrencilere çevre ve su duyarlılıklarını artırıcı, bilinçlendirici ve bilgilendirici eğitim vermeleri gerekmektedir. Ayrıca çevre bilinci ve su tüketimi konusunda ailelerin de eğitimi sağlanmalıdır. Yörede yer alan sivil toplum örgütlerinin ve medyanın da konu ile ilgili duyarlılık seviyesini yükseltmek amacıyla çalışmalarını artırarak devam ettirmeleri ve sadece proje bölgesinin değil, tüm ada halkının çevre ve su konusunda bilinçlenmelerini sağlamaları önerilmektedir.

KAYNAKLAR

- Akman, Y., Ketenoglu, O., Kurt, L., Düzenli, S., Güney, K. ve Kurt, F. (2012). Çevre Kirliliği (Çevre Biyolojisi). Ankara: Palme.
- Arkiş, S. (1992). The Effect of Water Conservation Unit Integrated into 6th Grade Junior High School Science Curriculum on the Water Related and Environmental Attitudes of the Students. Master Thesis, Ankara: METU.
- Aslan, O., Sağır, Ş. ve Cansaran, A. (2008). Çevre Tutum Ölçeği Uyarlaması ve İlköğretim Öğrencilerinin Çevre Tutumlarının Belirlenmesi. Selçuk Üniversitesi Ahmet Keleşoğlu Eğitim Fakültesi Dergisi, 25, 283-295.
- Auriault (1998). Une Strategie D' Education a l' eau de Lasociete Congre's International de Klasik. www.funredes.org/aqua/index_fr.htm.
- Aydın, O. (2007). Davranış Bilimine Giriş. Eskişehir: Anadolu Üniversitesi.
- Aydoğdu, M. ve Gezer, K. (2009). Çevre Bilimi (4. Baskı). Ankara: Anı.
- Bozkurt, O. (2010). Çevre Eğitimi (2. Baskı). Ankara: Pagem.
- Brody, M. (1995). Development of Curriculum Framework for Water Education for Educators, Scientist and Resource Maneger, Journal of Environmental Education, 26(4), 18-30.
- Cappellaro, E., Çoban, G., Akpınar, E., Yıldız, E. ve Ergin Ö. (2011). Yetişkinler İçin Yapılan Uygulamalı Çevre Eğitimine Bir Örnek: Su Farkındalığı Eğitimi. Türk Fen Eğitim Dergisi, 8(2), 157-173.
- Dervişoğlu, S. ve Kılıç, D. (2012). Davranış Teorisi Çerçevesinde Geliştirilen Su Tasarrufu Davranış Anketi. Hacettepe Üniversitesi Eğitim Fakültesi Orta Öğretim Fen ve Matematik Alanlar Eğitimi Bölümü.
- Fırat, A., Sepetçioğlu H. ve Kiraz, A. (2012). Öğretmen Adaylarının Yenilenebilir Enerjiye İlişkin Tutumlarının İncelenmesi. Ankara: Hacettepe Üniversitesi Eğitim Fakültesi Dergisi (H.U. Journal of Education) Özel Sayı, 1: 216-224, ISSN: 1300-5340.
- Güney, E. (2008). Genel Ortam Kirlenmesi. Ankara: Palme.
- Kabaş, D. (2004). Kadınların Çevre Sorunlarına İlişkin Bilgi Düzeyleri Ve Çevre Eğitimi. Yayınlanmamış Yüksek Lisans Tezi. TC Gazi Üniversitesi Eğitim Bilimleri Enstitüsü, Ankara.
- Karasar, N. (2007). Araştırmalarda rapor hazırlama. Ankara: Nobel Yayın Dağıtım.
- Kaya, E., Akıllı, M. ve Sezek, F. (2009) Lise Öğrencilerinin Çevreye Karşı Tutumlarının Cinsiyet Açısından İncelenmesi. Mehmet Akif Ersoy Üniversitesi. Yıl 9, Sayı:18.
- Kızılaslan, H. ve Kızılaslan, N. (2005). Çevre Konularında Kırsal Halkın Bilinç Düzeyi ve Davranışları (Tokat İli Artova İlçesi Örneği). ZKÜ Sosyal Bilimler Dergisi, 1(1), 68-89.
- Kızıroğlu, İ. (2001). Ekolojik Potpuri (1. Baskı). Ankara: Tekav.
- Köse, E. (2010). Lise Öğrencilerinin Çevreye Yönelik Tutumlarına Etki Eden Faktörler. Türk Fen Eğitim Dergisi. Atatürk Üniversitesi Kazım Karabekir Eğitim Fakültesi, Ortaöğretim Fen ve Matematik Alanları Eğitim Bölümü, Erzurum. 7, 198-211.
- Özdemir, Ş. (1997). Temel Ekoloji Bilgisi ve Çevre Sorunları. Ankara: Hatipoğlu.
- Özey, R. (2009). Çevre Sorunları (Geliştirilmiş 3. Baskı). İstanbul: Aktif.
- Özpinar, B. (2010). Ortaöğretim Öğrencilerinde Sosyo-Ekonomik Düzeyin Çevre Bilincine Etkisi. Yüksek Lisans Tezi. Ankara Üniversitesi Sosyal Bilimler Enstitüsü, Ankara.
- Sipahioğlu, Ş., Yıldız, K. ve Yılmaz, M. (2009). Çevre Bilimi ve Eğitimi (2. Baskı). Ankara: Gündüz.

- Şimşekli, Y. (2004). Çevre Bilincinin Geliştirilmesine Yönelik Çevre Etkinliklerine İlköğretim Okullarının Duyarlılığı. *Uludağ Üniversitesi Eğitim Fakültesi Dergisi*. 17(1), 83-92,
- Tezbaşaran, A. (1997). Likert Tipi Ölçek Geliştirme Kılavuzu. Ankara: Türk Psikologları Derneği.
- Tomanbay, M. (2008). Dünyada Su ve Küresel Isınma Sorunu. İstanbul: Ulusal Yayıncılık.
- Türk, M. (2011). Çevre Bilinci (Geliştirilmiş 2. Baskı). Ankara: Nobel.
- Türküm, A. (1998). Çağdaş Toplumda Çevre Sorunları ve Çevre Bilinci. Anadolü Üniversitesi.
- UNEP (1987). Our Common Future World Commission on Environmental and Development. UK Oxford University Press.
- Ünal, F. (2011). İlköğretimde Sürdürülebilir Çevre Eğitiminde Suyun Yeri. *Bilim ve Aklın Aydınlığında Eğitim*. 132, 68-73.
- WWAP (2006). Z'eme Rapport Mondial Des Nations Unies Sur La Mise En Valeur Des Ressources En Eau: (L'eau, Une Responsabilite Pratagee). Paris: UNESCO.
- WWAP (2009). World Water Assessment Programme. <http://www.unesco.org/water/wwap>
- Yavuz, S. (2006). Proje Tabanlı Öğrenme Modelinin Kimya Eğitimi Öğrencilerinin Çevre Bilgisi İle Çevreye Karşı Tutumlarına Olan Etkisinin Değerlendirilmesi. Yayımlanmamış Doktora Tezi. Hacettepe Üniversitesi Eğitim Bilimleri Enstitüsü, Ankara.

INVESTIGATING THE DISTINCTIVE ROLE OF THE INTERACTIVE WHITEBOARDS FOR MATHEMATICS TEACHING

Mauro De Vita, PhD
Scholar, CIP&T, K.U.Leuven, Dekenstraat 2, 3000 Belgium
Tel. +32 484 862802
email: mauro.devita@student.kuleuven.be

Lieven Verschaffel, Professor
CIP&T, K.U.Leuven, Dekenstraat 2, 3000 Belgium
tel. +32 16 326258

email: lieven.verschaffel@ped.kuleuven.be

Jan Elen, Professor
CIP&T, K.U.Leuven, Dekenstraat 2, 3000 Belgium
tel. +32 16 325733
email: jan.elen@ped.kuleuven.be

ABSTRACT: Interactive Whiteboards (IWBs) are a relatively new tool that provides interesting affordances in the classroom environment, such as construction of visualizations and multimedia. These affordances make IWBs an innovative tool with high potential for mathematics instructional environments. The research involved a small group of Italian mathematics teachers in secondary schools and aimed at exploiting the distinctive role of IWBs in mathematics teaching. Three essential elements were considered: the mathematical tasks on which students work, the discourse activities in the classroom and the support that IWBs give to the previous two elements. Analysing a first series of video recorded lessons, the teachers and the researcher engaged in a discussion about possible improvements relating the IWB use to enhance high-level mathematical tasks and productive discourse interaction. Outcomes of the discussion were used to design and enact a new set of lessons, again video recorded and analysed. Outcomes were compared with those of the previous set. Results show significant improvements in the tasks' quality, in the classroom dynamics and in the exploitation of IWBs affordances. What emerged from the study is that IWBs technology may be used to enrich the lessons' experience and that an attentive orchestration by the teacher leads to the construction of an effective and beneficial learning and teaching environment.

Keywords: Interactive Whiteboards, Mathematics Education, Teaching/learning Strategies.

INTRODUCTION

Interactive whiteboard (IWB) systems comprise a computer linked to a data projector and a large touch-sensitive electronic board displaying the projected image. IWBs are equipped with dedicated software, but might also be considered as a digital hub which allows the integration of Internet or other hardware resources, as orchestrated by the teacher and the students.

Objects from other technologies, such as geometric dynamic software, can easily be displayed on the IWB, and can be directly manipulated by teachers and students to provide an interactive experience in lessons that is accessible to all. Results from these manipulations can also be stored and retrieved in future lessons to further discussions (Mercer, Hennessy & Warwick. 2010).

Today, the IWB is an increasingly popular educational technology all over the world; in 2013 globally one in eight elementary and secondary classrooms (34 million teaching spaces) had an IWB and by 2015, one in five will have one (Hennessy & London, 2013). It is found in 80% of British classrooms and its prevalence is rapidly increasing in a number of other countries too, notably the Netherlands, Denmark, Australia and the United States. Further rapid growth is expected in the next few years (Hennessy & London, 2013).

Different studies highlighted the IWB potentialities. Many teachers have found the IWB to be an important and highly motivating teaching resource (Warwick & Kershner, 2008). Several studies (e.g. Higgins et al., 2005; Moss et al., 2007, Somekh et al., 2007) state that IWBs aid the teaching of difficult, abstract and complex ideas, improve students' motivation to learn, increase lessons' pace, promote classroom interaction and reinforce

conceptual learning through the use of animation or visual representation. Different authors (e.g., Beauchamp, Kennewell, Tanner & Jones, 2010; Glover, Miller, Averis & Door, 2007; Jewitt, Moss & Cardini, 2007) presented classroom observations in which teachers working with IWBs developed their own technological fluency, promoted students' group work activities for authentic problems, and for innovative processes of exploration. Other studies (e.g. Jewitt et al., 2007; Kennewell, Tanner, Jones, & Beauchamp, 2008; Miller & Glover, 2007) reported improvements in students' conceptual and cognitive understanding. The IWB is argued to provide collaborative opportunities for reasoning, hypothesis testing and interpretation that go well beyond those afforded by more established classroom devices. Hennessy, Deaney, Ruthven and Winterbottom (2007) stated it provides a "dynamic and manipulable object of joint reference which offers new forms of support for interactivity" (Hennessy et al., 2007, p. 284).

Despite these positive observations current evidence from the literature (Glover et al., 2007; Miller & Glover, 2010; Smith, Hardman & Higgins, 2006) points to teachers' limited acquaintance with the educational potential of IWBs; many teachers seem to use the IWB merely as a large-scale visual blackboard or presentation tool. So, often teachers do not succeed in exploiting the above-mentioned more innovative pedagogical advantages of IWBs (Moss et al., 2007, Somekh et al., 2007). In fact, if IWBs are merely used in a presentation mode, they may induce teachers to teach in an expository way, reducing rather than stimulating students' activity and interactivity and exploiting the affordances of a media-rich content only for surface aims. Thus the use of IWBs may have no significant impact on teachers' existing pedagogy and more specifically on enhancing high quality interaction and thinking processes.

The pedagogy associated with IWBs use requires further investigations and in-depth analyses to understand better what underlies teachers' difficulties with exploiting the affordances offered by IWBs and to stimulate the design of new kinds of learning environments (Glover & Miller, 2009; Kennewell et al., 2008, Warwick, Mercer, Kershner & Kleine Staarman 2010). Hennessy and London (2013, p.13) observe that "IWBs are deceptively complex and to fully utilise the interactive aspects of the technology, teachers must invest time to build confidence, design resources, adapt practices and learn to harness their power". Teachers need time to develop the knowledge to exploit technology in ways that effectively enhance student learning.

The research reported here aimed at exploring and exploiting the distinctive role of IWBs in teaching environments, for supporting and contextualising productive dialogue and other forms of interaction in the classroom and developing opportunities for students' learning, in the domain of mathematics education.

THEORETICAL FRAMEWORK

Besides technology, two other basic factors for learning are the tasks in which students are engaged and the nature of classroom activities (Collins, Brown, & Newman, 1989). Therefore, in constructing the theoretical framework for the research, three elements were individuated as essential ingredients of the development of an IWB-supported interactive environment for mathematics teaching and learning:

- the quality of the interaction with the mathematical content, i.e. tasks in which students are engaged;
- the quality of discourse interaction between the teacher and the students and amongst the students, intended as indicator of classroom activities;
- the support that IWB may provide to the two previous elements, i.e. mathematical content and discourse interaction.

The first element refers to the modality and the quality of the mathematical tasks addressed in the classroom. Most mathematics educators have argued that full understanding of mathematics consists of more than knowledge of mathematical concepts, principles, techniques, procedures (e.g. Schoenfeld 1992). It is important to teach students that doing mathematics not only consists in applying standard procedures generally explicated in school textbooks, but in engaging in the processes of mathematical thinking, in reasoning about main mathematical concepts and in solving and managing mathematical problems. Mathematics learning is an essentially constructive activity (Schoenfeld 1992). In effective mathematics instruction a teacher assists students to engage productively with a problem (Hiebert & Grouws, 2007). Teachers have an important role in guiding students' mathematical development by discerning and making explicit the key mathematical ideas in different tasks, deciding which solution strategies displayed by students are worth, and encouraging consideration of those that merit further inquiry (Silver et al., 2005). Hiebert and Grouws (2007) analysed in depth the different approaches to mathematics teaching. They discerned between *teaching for skill efficiency*, that is accurate, smooth and rapid execution of mathematical procedures, and *teaching for conceptual understanding*, i.e. "the mental connection among mathematical facts, procedures and ideas" (Hiebert & Grouws, 2007, p.380). In the pattern of teaching for developing conceptual understanding they individuated two different key feature: *teachers and students attending explicitly to concepts*, i.e. treating mathematical

connections in an explicit way, discussing the mathematical meaning underlying procedures, attending to the relationships among mathematical ideas, etc., and *students struggling with important mathematics*, i.e. expending efforts to make sense of mathematics, figuring something out that is not immediately apparent, solving problems “that are within reach and grappling with key mathematical ideas that are comprehensible but not yet well formed” (Hiebert & Grouws, 2007, p.387).

The framework used for classifying the mathematical tasks was elaborated by Stein, Grover and Henningsen (1996). Stein et al. (1996) define a *mathematical task* as a classroom activity the purpose of which is to focus students' attention on a particular mathematical idea; the kind of mathematical tasks with which students become engaged determines not only what substance they learn but also how they come to think about, develop, use, and make sense of mathematics. According to Stein et al. (1996), “the tasks used in mathematics classrooms highly influence the kinds of thinking processes in which students engage” (p.462). So, their concept and operationalization of mathematical task is well-suited for analysing the first element of our theoretical framework as described above. Stein and Smith (1998a) classify tasks at two levels in four categories of cognitive demand:

Low level tasks (corresponding to *teaching for skill efficiency* by Hiebert and Grouws, 2007):

- *Memorization*: committing facts, rules, formulas or definitions to memory;
- *Procedures without connections to concepts or meaning*: the use of formulas, algorithms, or procedures *without connection* to concepts, understanding, or meaning;

High level tasks (corresponding to *teaching for conceptual understanding* by Hiebert and Grouws, 2007):

- *Procedures with connections to concepts and meaning*: the use of formulas, algorithms, or procedures *with connection* to concepts, understanding, or meaning;
- *Doing mathematics*: including complex mathematical thinking and reasoning activities such as making and testing conjectures, framing problems, looking for patterns, and so on.

Furthermore, mathematics learning is conceived as an inherently social (as well as cognitive) activity (Collins, et al., 1989; Schoenfeld, 1992). Therefore, the second aspect of the theoretical framework concerns the discourse interaction within the classroom between the teacher and the students and amongst the students.

Discourse interaction grounds on the concept of ‘dialogic teaching’ (Alexander, 2008; Mercer, 2004) as a means to promote and enhance students’ learning. Basically (Wolfe & Alexander, 2008), a dialogic approach is collective (teachers and students addressing the learning task together), reciprocal (teachers and students listening to each other to share ideas and consider alternative viewpoints), and cumulative (teachers and students building on their own and each others’ ideas to chain them into coherent lines of thinking and enquiry). Often directive forms of teaching consist of closed teacher questions, short student answers which teachers do not build upon, and superficial feedback (Mercer et al., 2010). The dialogic approach to teaching aims to orchestrating classroom talk and activity through open-ended tasks, high level open questioning, high level classroom discussions, topics explorations, sharing ideas and co-constructing interpretations.

A peculiar modality of discourse interaction is enacted in the problem solving work developed by students in small groups, and its presentation in front of the whole classroom for further discussion. According to Collins et al. (1989) and Schoenfeld (1983), small group problem solving sessions favour discussion and argumentation in choosing alternative solution methods, improve students’ collaboration and self-confidence and encourage more critical and elaborated contributions from pupils. Besides solving problems in small groups other forms of dialogic teaching promote an active involvement of the students, such as high quality whole class discussion in which students engage in the same problem and compare the different ways they solved it, or explore different problems with similar solution methods.

Analysis of discourse interaction based on the framework developed by Smith et al. (2006). Grounding on the concept of ‘dialogic teaching’, they conducted a study in which they looked specifically at the different types of discourse moves, and consequently at the different teaching styles in an IWB environment. The scheme of their analysis primarily focused on the three-part IRF structure of a discourse unit (Sinclair & Coulthard, 1975): an *Initiation*, usually in the form of teacher’s explain or a question submitted to the students, a *Response* in which students attempt to answer the question and a *Feedback*, in which the teacher provides some form of feedback to the student’s response. Each of the three parts is further divided into more detailed elements. *Initiation* includes *closed questions*, *open questions*, *students’ questions*, and *explain*. *Response* includes *single student answer*, *choral response*, *spontaneous contribution* and *general discussion*. Finally, *Feedback* includes *Repeat question* (questions that shape the course of implementation provide teacher with specific ways of focusing students on the key mathematical ideas leaving less “in the moment” decision-making regarding next instructional moves),

Uptake question (teacher incorporate students' answers into subsequent questions), *Probe* (teacher stimulates students for further elaboration), and *Refocus* (get students back on task).

The third central element refers to different kinds of support that IWBs may provide to the previous two aspects, mathematical tasks and discourse moves.

IWBs provide a multimodality environment wherein images, texts, objects from other software can be combined and manipulated directly on the screen by teacher and students. It might also be considered as a digital hub which allows the integration of Internet or other resources, as orchestrated by the teacher and the students. Tools provided as part of the IWB software package include, besides general functions, also some specific mathematical tools, such as a calculator, numbers line, Cartesian axis, etc.

Thus, the IWB affords a flexible powerful environment, where both teachers' modelling and coaching activities and students' exploring activities can be easily included. In mathematics lessons, the affordance to use external software, such as dynamic geometrical software (e.g., Geogebra) or spreadsheets in combination with functions as highlighting and annotating, is especially valuable. The potentialities of the dynamic geometry software are emphasized by employing it in an IWB setting rather than being used on individual computers, allowing affordances for whole class discussion and reflection. As the IWB becomes the centre of the classroom activities, it allows a dynamic use of the resources that favours the creation of a learning environment in which the participants actively communicate and engage in the practice of solving problems in a cooperative way. Students can get engaged in the discussion about the topics presented at the IWB and improve their critic abilities monitoring the line of reasoning. Furthermore, IWBs can favour collaborative students' group activities guided and mediated by the teacher (Warwick et al. 2010). Reflection is enhanced by the IWB affordance to store and retrieve the course of the lesson (including transformed objects); saved lessons may be 'replayed' for further discussion.

The tool used for analysing the third element of the theoretical framework, namely the different kinds of support that IWBs may provide to the previous two elements, mathematical tasks and discourse moves, is based on the work of Kennewell and Beauchamp (2007), who investigated how teachers used features of IWBs to enhance learning activities in a set of observed lessons. These activities concerned learner-IWB interaction, teacher-IWB interaction, learner-teacher and learner-learner interaction through the IWB. The authors identified teacher and learner actions supported by IWB features and built a classification framework concerning the impact of these actions on learning. These actions included *Composing* (using IWB as a tool to elaborate or record ideas), *Editing* (easily changing the data stored and displayed), *Selecting* (choosing resources or procedures), *Comparing* (comparing features of same object from different views or comparing different items), *Retrieving* (easily using stored resources), *Apprehending* (students interpreting the display, i.e. text, images, sound, diagrams), *Focusing* (drawing attention to particular aspects of a process or representation), *Transforming* (changing the way data are displayed), *Collating* (bringing together a variety of items from different sources), *Annotating* (adding notes to a process or a representation), *Repeating* (iterating an automated or stored process), *Modelling* (simulating a process by representing relationships between variables), *Revisiting* (returning to an activity with a different focus), *Undoing* (reversing an action). As in mathematics lessons external software is often used, the framework was adapted in this study by dividing the action *Composing* in two categories, *Composing using software* (indicates the elaboration through external software) and *Composing without software* (elaboration without external software).

The three analytic tools are summarized in Table 1.

Tab. 1. Frameworks Used In The Analysis.

<p>Mathematical tasks</p> <p><i>Low level tasks</i></p> <ul style="list-style-type: none"> • <i>Memorization</i> • <i>Procedures without connections to concepts or meaning</i> <p><i>High level tasks</i></p> <p><i>Procedures with connections to concepts and meaning:</i></p> <p><i>Doing mathematics</i></p>
<p>Discourse moves</p> <p><i>Initiation:</i></p> <p><i>Teacher's open question</i></p> <p><i>Teacher's closed question</i></p> <p><i>Student's question</i></p> <p><i>Explain</i></p>

<i>Direct</i> <i>Response</i> <i>Single student answer</i> <i>Choral response</i> <i>Spontaneous contribution</i> <i>General discussion</i> <i>Feedback</i> <i>Repeat question</i> <i>Uptake question</i> <i>Probe</i> <i>Refocus</i>	
IWB actions	
<i>Composing without software</i> <i>Composing using software</i> <i>Editing</i> <i>Selecting</i> <i>Comparing</i> <i>Retrieving</i> <i>Apprehending</i>	<i>Focusing</i> <i>Transforming</i> <i>Collating</i> <i>Annotating</i> <i>Repeating</i> <i>Modelling</i> <i>Revisiting</i> <i>Undoing</i>

In line with these three elements of the theoretical framework, this study addressed the following three research questions:

how can the teacher enhance the quality of the interaction with mathematical tasks in an IWB supported mathematics lesson?

how can the teacher improve the discourse interaction within the classroom between the teacher and the students and amongst students in an IWB supported mathematics lesson?

what precise kinds of support IWB may contribute to the quality of mathematical tasks execution and to the discourse interaction?

METHOD

The research involved five Italian mathematics teachers in secondary schools, in the period February-May 2013, who volunteered to participate in discussing the design and in video-recording lessons. The research went through two phases of video-recorded lessons in the classrooms, interlaced by discussion between the researcher and the teachers and design of a new set of lessons, as detailed below. Comparison between the first and the second lessons set helped to understand which kind of configuration would better support mathematical understanding and interactive learning.

The classrooms in which the lessons were video recorded were all provided with a stable IWB, and students were accustomed to use it. The range of the students' age varied from twelve to seventeen years old (High School grades 2 to 7).

The research went through four different phases. In the first phase (February) the five teachers involved in the research developed one or two lessons about a mathematics topic in order to exploit IWB affordances that they considered effective. Lessons were developed by each teacher individually, and the topic was chosen freely and differently by each of them. The lessons were taught in the presence of the researcher and video recorded by him. The researcher analysed the lessons and coded them on the basis of three main variables, i.e., mathematical tasks, discourse interaction and support provided by IWB, following for each element the proposed classification. The three kinds of coding were carried out by registering what was happening in the classroom every 30 seconds, from the beginning to the end of the lesson. An independent observer coded randomly chosen fragments of about ten minutes of each of the taught lessons. The achieved intercoder reliability was calculated using the criterion that the observer's coded responses were considered equivalent only if they are identical (Lombard, Snyder-Duch, & Bracken, 2002). For the analysis of mathematical tasks reliability was complete, with 100% equivalent responses; for discourse interaction reliability averaged 90% and for IWB support 92%.

In the second phase the teachers' group jointly with the researcher discussed some fragments of the lessons and the results of the researcher's classification. The fragments were selected upon indication of the teachers and the researcher, choosing the most significant in the use of IWBs. Three discussion groups were held in March. Teachers and researcher engaged in discourse about students' levels of thinking and achievement of the mathematical tasks, about the role they had in stimulating students' contribution in the lesson context, and about the IWB contribution to the classroom interactivity.

In the third phase, grounding on the analysis of the previous phase, the joint group of teachers, guided by the researcher, designed the main lines of a new set of lessons to teach, again about different topics. General outlines of the lesson design were decided upon collectively, but each teacher refined then her/his own lesson highlighting the important role of the IWB in its design.

In the fourth phase (May) each teacher taught the lesson she/he prepared. These were again video recorded and recordings were analysed using the same analytic tools than in the first phase of the analysis. The researcher compared then the first set (February) with the second set (May) of lessons, checking changes and improvements in mathematical tasks, dialogue interactivity and IWB support. Results from this comparison were briefly discussed with the teachers (the team intends to carry on with the work) and are presented in the following section.

RESULTS

Findings show considerable changes between the two sets of recorded lessons.

Mathematical Tasks

In February lessons topics concerned ellipse's construction, sinus function, derivative calculus, exponential growth and geometry properties of parallels. All the lessons were accurately prepared. The mathematical tasks were classified by the researcher as *procedures with connections to concepts and meaning* in all the lessons except one. In some of them the teacher linked the lesson to previously developed dynamic geometrical files, operating with them in front of the classroom and showing connections between different variables and between different important mathematical concepts; in other lessons the teacher started from a geometrical concept and developed it through the lesson, building geometrical constructions and linking them to real world objects, and guiding students in explorations of the inherent mathematical properties.

In the discussions held in March, February lessons were generally considered rather 'directive' and teacher centred. In this regard one teacher observed: "IWB poses many constraints in the teacher's work and lesson's preparation. I feel freer when I do not use the IWB. When I prepare an IWB lesson I feel obliged to follow the prepared scheme and I give less space to the students' suggestions. This is an aspect that may favour a teacher centred lesson."

Nevertheless, all the participants (teachers and researcher) agreed about the appropriateness to move the centre of the lesson focus from the teacher to the students and improve the collaboration between students and teacher and between students themselves. A possible solution was individuated shifting the mathematical tasks from the level *procedures with connections to concepts and meaning* to the level *doing mathematics*, i.e. problem solving. Interactivity in the lessons might take advantage of this shift providing students more opportunities to develop their potential while struggling with stimulating problems. The discussion engaged in affordances and difficulties to use problem solving in the curriculum, due to lack of time and different lessons' organisation. Problem solving activities require from teachers a considerable effort, in terms of the interactive demands on them during the lesson. During the discussion, one teacher observed that "students are not accustomed to problem solving, and often require teachers to explain". A second teacher remarked how "perhaps students should be given more time to reflect and carry on with their own answers". Finally, the whole group decided to develop lessons through this kind of task. The group also highlighted and approved the utility of working on realistic tasks, situating abstract tasks in more authentic contexts, so that students could understand the relevance of the work.

The May topics concerned exponential law, derivative calculus, geometry properties of the triangle, statistic indexes. All the mathematical tasks were classified as *doing mathematics*. They required students to analyze the task and actively examine alternative solution strategies and solutions, exploring and understanding the nature of mathematical concepts, processes, or relationships. All the tasks required complex and non-algorithmic thinking, where a pathway is not explicitly suggested by the task, task instructions, or a worked-out example. To promote the maintenance of high-level cognitive demands (Schoenfeld, 1992; Schoenfeld, 2006; Stein & Smith, 1998b), teachers encouraged students in engaging in cognitive effort, in making reasoning explicit, in drawing conceptual connections and in struggling with the tasks. In three lessons (over five) the tasks were based on real world problems.

Discourse Interaction

Analysing the discourse interaction through the tool presented in the theoretical framework, the February lessons resulted rather teacher centred, with a prevalence of teacher's explain, closed questions and single student's answer. To increase students' participation and involving them in cooperation and co-constructing knowledge, during the March discussions the team decided to organize students in small groups working in problem solving. These groups had to present their solutions at the IWB, discussing them with the entire classroom, and were encouraged by the teacher to give justifications, explanations and meaning of their solutions. The aim was to involve more directly students in the implementation of the lessons, increasing cooperation and communication among students. Indeed, students were generally given more space in the course of the May lessons. From February to May *initiation* decreased from 42.2% to 20%, *responses* increased from 32.4% to 60.2%, mainly because of *spontaneous contribution*, and *feedback* passed from 24.8% to 20%. *Initiation* showed a significant increase of *open questions* (7.8% → 12.6%) and a strong decrease of teacher's *explain* (23% → 5.6%), *closed questions* and *student's questions* practically disappeared. In *Responses*, the prevalent modality was *spontaneous contributions*, intended as students reporting findings of the work groups at the IWB (2.6% → 44.8%), *general discussions* increased (1.2% → 8.8), while *single student answers* drastically decreased (24% → 4.4%). In *Feedback*, the percentage of *uptake questions* (in which teacher stimulates further elaboration starting from students' answers) was the higher (9.2%). The difference between discourse moves in May and February lessons is statistically significant ($\chi^2 = 133.68$; $p < .0001$). Results are shown in Table 2.

Tab. 2 Changes In Discourse Moves From February To May (% Over Total Lessons)

	February (N=497)	May (N=501)
Discourse moves	Mean percentages	Mean percentages
Initiation		
open questions	7.9	12.5
closed questions	6.6	0
students questions	2	1
explain	23.1	5.6
direct	2.8	0.8
<i>Subtotal</i>	42.4	19.9
Response		
Single student answer	24.1	4.4
Choral response	4.6	2.2
spontaneous contribution	2.6	44.7
general discussion	1.3	8.8
<i>Subtotal</i>	32.6	60.1
Feedback		
repeat questions	6.6	4.2
uptake questions	7.7	9.2
probe	8.1	5.2
refocus	2.6	1.4
<i>Subtotal</i>	25	20

IWB Support

The third element of the theoretical framework, IWB support, was analysed using the tool based on the work of Kennewell and Beauchamp (2007), presented above. Results from analysis showed that in February the IWB mainly supported the teacher's discourse and was directly managed by her/him. Even when students were involved they were always directed by the teacher, acting rather as teacher's assistants. Teachers mostly used the IWB as a normal blackboard (*composing without software*) or as a mean to show students different texts or images. Nevertheless, they also made large use of external software, i.e. Geogebra, for geometrical constructions and algebraic elaborations.

During the March discussions all participants stressed the IWB relevance in modelling the shape of the lesson as strong centre of attention and reflection, and in enhancing mathematical understanding, especially using external software, and exploiting the multimodality IWB affordances. Different teachers stated that IWB concentrates attention on the salient points, that lessons are prepared more accurately, that IWB favours more cooperation and discussion with respect to a lesson with a normal blackboard or to a computer laboratory. IWB use did not exclude the use of other didactical instruments (textbook, hands work, drawings, cardboards, etc.). Orchestrating

IWB lessons requires a considerable effort from the teachers, both in terms of lesson preparation and the interactive demands on them during the lesson.

An important aspect stressed by all is the need of having the IWB available in the daily work in the classroom. Analysing the different IWB actions and their use in the implementation of the lesson, some actions appeared to be more effective in developing mathematical tasks and supported more than other an interactive, multimodal use of IWB fostering mathematical conceptual understanding:

composing using software typically dynamic geometry software as Geogebra or spreadsheet as Excel; the software Geogebra is managed for exploration and elaboration, looking for connections or theorem demonstrations. As one teacher said, ‘it gets students used to see mathematical objects move’;
comparing, i.e. same object are analysed from different points of view;
transforming, i.e. changing data representations;
modelling, simulation of a process by representing relationships between variables.

During the lessons recorded in May, presenting their works students’ groups made large use of these effective actions, displaying multiple representations in a dynamic way often through mathematical software, such as Geogebra or Excel. Their solutions were presented to the whole classroom, inviting other students to participate, to criticize and to suggest better ways to solve the problems. The IWB was used constantly during all the lessons (93% of the total lessons time), except for some short periods in which students worked in small groups to elaborate their answers.

A comparison of the data in February and in May shows a relevant decrease in *composing without software* (27.8% → 17.8%) and in *apprehending* (26% → 14.2%), actions which might connote a more traditional IWB use. On the other hand, actions significant for an interactive and multimodal IWB use increase: *composing using software* 22% → 26.2%; *modelling* 10.6% → 17; *comparing* 2.2% → 5.2%; *transforming* 2% → 7.6%; %. Overall, actions significant for an interactive and multimodal IWB use cover 56% of the lesson time, while in February it was only 36.6%. The difference between IWB actions in May and February lessons is statistically significant ($\chi^2 = 64.90$; $p < .0001$). Data are shown in Table 3.

Tab. 3 Changes In IWB Actions (% Over Actions Total In All Lessons)

	February (N=503)	May (N=499)
Action	Mean percentages	Mean percentages
<i>Composing without software</i>	27.5	17.9
<i>Composing using software</i>	22	26.2
<i>Editing</i>	0.2	2.6
<i>Selecting</i>	0	0.2
<i>Comparing</i>	2.2	5.2
<i>Retrieving</i>	6	4
<i>Apprehending</i>	25.8	14.3
<i>Focusing</i>	0.6	2.2
<i>Transforming</i>	2	7.6
<i>Collating</i>	0	0.2
<i>Annotating</i>	2.2	1.4
<i>Repeating</i>	0	0
<i>Modelling</i>	10.5	17
<i>Revisiting</i>	0.4	1.2
<i>Undoing</i>	0.6	0

DISCUSSION AND CONCLUSIONS

By relating the IWB use to the design of mathematical tasks and ways of discourse interaction, teachers have been stimulated to look for effective ways of exploiting its interactive and multimodal features to support the enhancing of two main elements of the classroom practice.

In the first set of lessons, the IWB mainly supported the teachers’ discourse. IWB offered teachers a powerful instrument for the kind of high-level mathematical tasks defined as *procedures with connection to concepts and meaning*. The limit was that lessons were mainly teacher centred: though students were often involved in co-

operating with the teacher, directly manipulating objects and annotating texts, the thread of the discourse was mainly directed by the teacher.

To increase students' participation the challenge was to design and implement a teaching and learning environment in which students would be more involved in handling the lesson and in building knowledge. As a first step, based on the teachers' critical reflections on the February lessons supported by the theoretical/analytic framework provided by the researcher, the team decided to try to change the kind of mathematical tasks from *procedures with connection to concepts and meaning* to *doing mathematics*, i.e. activities of problem solving.

This change in mathematical tasks helped also in modifying the discourse interaction. Students were more actively involved in managing the lesson. Direct intervention of the teacher, in form of explanations, and questioning in form of closed questions played a minor role, while open questioning and, overall, students' spontaneous contributions, in the form of exposition and elaboration of the group works, had a preeminent part in the development of the classroom discourse; the teacher assisted students in engaging productively with a problem, increasing interaction amongst students and with the teacher.

In addition, when looking for ways to make the quality of the interaction better, the teachers came up with the idea of working with group work, directly involving students in the development and implementation of the lessons. So doing, the teachers promoted an environment in which students were expected to serve as resources to each other in working on mathematical problems, collaborating to develop solutions and sharing their strategies with each other. Therefore, students worked on the tasks in small groups and jointly presented the group solutions at the IWB, discussing them with the entire classroom and in this way improving also a high-quality discussion in the whole classroom.

In February the IWB mostly supported the teacher discourse. In May students were much more involved in using the IWB by their own. They used the IWB exploring geometrical properties of an object, researching the best mathematical model of physical and demographic phenomena, investigating different strategies of solving difficult calculus problems. In these activities students compared different data representations, symbols, tables, charts, graphs, transforming from one representation to the other and looking for the best one. This use was at least partially sustained by teachers' scaffolding whenever students needed guide in discerning and choosing different mathematical strategies or lacked technological experience. The difference between February and May is reflected by the change in IWB actions employed in the lessons. In elaborating their group works students made large use of multimodal IWB actions, such as simulation of processes, comparison between different ways to represent a phenomenon, use of dynamic external software. Actions that might characterize a more traditional use of the IWB, such as displaying texts or images and composing like in a traditional board, decreased significantly. The IWB was exploited like a 'laboratory' for a better understanding of mathematical tasks and connections. Collective reasoning was actualised within a range of evolving multimodal representations that could beneficially be managed, organised, interpreted, saved and revisited so that connections and elaborations were created cumulatively over time. Of course the IWB offers students a large range of affordances, but also involves the necessary competencies, both in manipulating objects from other technologies, e.g. software as Geogebra or Excel, and in managing the tools included in the same IWB.

What emerges from this study is that IWBs technology may be used to enrich the lessons and the students' experience of challenging mathematical situations. Teachers may enhance the quality of interaction with mathematical tasks through an accurate balancing between theoretical attention to mathematical concepts and problem solving activities that involve students more directly. The discourse interaction may be improved basing less on direct explain and closed questions and leaving more space to students' discussions and autonomous works. The IWB sustains the two previous elements affording flexible and powerful tools and actions that allow students to visualize multiple representations, analysing, comparing and modelling relationships between variables. Mathematical tasks, discourse interaction and IWB support play each an important role but it is their attentive orchestration and combination by the teacher that leads to the construction of an effective and beneficial learning and teaching environment,

As stated by Hennessy and London (2013), the key difference between the IWB and a set of desktop computers is that the IWB allows technology to be used flexibly, and it brings technology firmly into the classroom and away from confinement to centrally located computer labs.

Resources and findings described in this paper may be useful in stimulating discussion about pedagogical practices in classrooms where the IWB is currently used and in improving a wider professional development for in-service teachers and pre-service teachers.

Surely, further research is needed to understand what important aspects of applications and modelling are touched (or not touched) upon by the technological environment and how the culture of the classroom is influenced by the presence of this technological device.

ACKNOWLEDGEMENTS

We are very grateful to the teachers and students who willingly participated in the study.

REFERENCES

- Alexander, R.J. (2008). *Towards Dialogic Teaching. Rethinking classroom talk*. (4th ed.). York, GB: Dialogos
- Bantchev, B. B. (2010). *A Brief Tour to Dynamic Geometry Software*.
Retrieved from: <http://www.math.bas.bg/omi/DidMod/Articles/BB-dgs.pdf>
- Beauchamp, G., Kennewell, S., Tanner H., & Jones S. (2010). Interactive whiteboards and all that jazz: the contribution of musical metaphors to the analysis of classroom activity with interactive technologies. *Technology, Pedagogy and Education*, 19 (2), 142 -157.
- Beauchamp, G., & Kennewell, S., (2010). Interactivity in the classroom and its impact on learning. *Computers & Education* 54 (3), 759-766.
- Collins, A., Brown J. S., & Newman, S. E. (1989). Cognitive Apprenticeship: Teaching the Crafts of Reading, Writing and Mathematics. In L.B. Resnick (ed) *Knowledge, Learning and Instruction, Essays in honour of Robert Glaser* (pp. 453-494). Hillsdale, N.J: Lawrence Erlbaum Associates.
- Glover, D., Miller, D., Averis, D., & Door, V. (2007). The evolution of an effective pedagogy for teachers using the interactive whiteboard in mathematics and modern languages: an empirical analysis from the secondary sector. *Learning, Media and Technology*, 32 (1), 5-20.
- Glover, D., & Miller, D. (2009). Optimising the use of interactive whiteboards: an application of developmental work research (DWR) in UK , *Professional Development in Education* 35(3), 469-483.
- Hennessy, S., Deaney, R., Ruthven, K., & Winterbottom, M. (2007). Pedagogical strategies for using the interactive whiteboard to foster learner participation in school science. *Learning, Media and Technology*, 32(3), 283–301.
- Hennessy, S., & London, L. (2013). *Learning from international experiences with interactive whiteboards: The role of professional development in integrating the technology*. OECD Education Working Paper 89.
- Hiebert, J., & Grouws, D. A. (2007). The effects of classroom mathematics teaching on students' learning. In F. K. Lester (Ed.), *Second Handbook of Research on Mathematics Teaching and Learning* (pp. 371–404). Charlotte, NC: Information Age Publishing.
- Higgins, S., Falzon, C., Hall, I., Moseley, D., Smith, F., Smith, H. & Wall, K. (2005) *Embedding ICT In The Literacy And Numeracy Strategies: Final Report*. Newcastle, Newcastle University.
- Jewitt, C., Moss, G., & Cardini, A. (2007). Pace, interactivity and multimodality in teachers' design of texts for interactive whiteboards in the secondary school classroom. , *Learning, Media and Technology*, 32 (3), 302-318.
- Kennewell, S., Tanner, H., Jones, S., & Beauchamp, G. (2008). Analysing the use of interactive technology to implement interactive teaching. *Journal of Computer Assisted Learning*, 24(1), 61-73.
- Kennewell, S., & Beauchamp, G.(2007). The features of interactive whiteboards and their influence on learning, *Learning, Media and Technology*, 32(3), 227-241.
- Lombard, M., Snyder-Duch, J., and Bracken, C. C. (2002). Content Analysis in Mass Communication: Assessment and reporting of intercoder reliability. *Human Communication Research*, 28, 587 – 604.
- Mercer, N. (2004) Sociocultural discourse analysis: analysing classroom talk as a social mode of thinking. *Journal of Applied Linguistics*, 1(2), 137-168.
- Mercer, N., Hennessy, S., & Warwick, P. (2010). Using interactive whiteboards to orchestrate classroom dialogue. *Technology, Pedagogy and Education*, 19 (2), 195–209.
- Miller, D.J., & Glover, D. (2007). Into the unknown: the professional development induction experience of secondary mathematics teachers using interactive whiteboard technology. *Learning, Media and Technology*, 32(3), 319-331.
- Miller, D.J., & Glover, D. (2010). Presentation or mediation: is there a need for 'interactive whiteboard technology-proficient' teachers in secondary mathematics??. *Technology, Pedagogy and Education*, 19 (2), 253- 259.
- Moss, G., Jewitt, C., Levaãç,R., Armstrong, V., Cardini, A., & Castle, F., (2007) *The Interactive Whiteboards, Pedagogy and Pupil Performance Evaluation: An Evaluation of the Schools Whiteboard Expansion (SWE) Project: London Challenge* , School of Educational Foundations and Policy Studies, Institute of Education, University of London.

- Schoenfeld, A. H. (1983). Problem solving in the mathematics curriculum: A report, recommendations and an annotated bibliography. *The Mathematical Association of America, MAA Notes, 1*.
- Schoenfeld, A. H. (1992). Learning to think mathematically: Problem solving, metacognition, and sense-making in mathematics. In D. Grouws (Ed.), *Handbook for Research on Mathematics Teaching and Learning* (pp. 334-370). New York, NY: MacMillan.
- Schoenfeld, A. H. (2006). Mathematics teaching and learning. In P. A. Alexander & P. H. Winne (Eds.), *Handbook of Educational Psychology* (2nd ed.) (pp. 479-510). Mahwah, NJ: Erlbaum.
- Silver, E., Goussein, H., Gosen, D., Charambolous, C. & Font Strawhun, B. (2005). Moving from rhetoric to praxis: Issues faced by teachers in having students consider multiple solutions for problems in the mathematics classroom. *The Journal of Mathematical Behavior, 24* (3-4), 287–301.
- Sinclair, J. & Coulthard, M. (1975). *Towards an Analysis of Discourse*. Oxford, GB: Oxford University Press
- Smith, F., Hardman, F. & Higgins, S. (2006) The impact of interactive whiteboards on teacher-pupil interaction in the national literacy and numeracy strategies. *British Educational Research Journal, 32*(3), 443–457.
- Somekh, B., M. Haldane, Jones, K., Lewin, C., Steadman, S., Scrimshaw, P., Sing, S., & Woodrow, D. (2007). *Evaluation of the Primary Schools Whiteboard Expansion Project*. London, Report to the Department for Education and Skills.
- Stein, M.K., Grover, B., & Henningsen, M. (1996). Building student capacity for mathematical thinking and reasoning: an analysis of mathematical tasks used in reform classrooms. *American Educational Research Journal, 33*, 455-488.
- Stein, M.K., & Smith, M. (1998 a). Mathematical tasks as a framework for reflection: from research to practice. *Mathematics Teaching in the Middle School, 3* (4), 268-275.
- Stein, M.K., & Smith, M. (1998 b). Reflections on practice: selecting and creating mathematical tasks: from research to practice. *Mathematics Teaching in the Middle School, 3* (5), 344-350.
- Straesser, R. (2001). Cabri-géomètre: Does Dynamic Geometry Software (DGS) Change Geometry and its Teaching and Learning? *International Journal of Computers for Mathematical Learning, 6* (3), 319-333.
- Warwick, P., & Kershner, R. (2008). Primary teachers' understanding of the interactive whiteboard as a tool for children's collaborative learning and knowledge-building. *Learning, Media and Technology, 33*(4), 269–287.
- Warwick, P., N. Mercer, R. Kershner & Kleine Staarman, J. (2010), In the Mind and in the Technology: The Vicarious Presence of the Teacher in Pupils' Learning of Science in Collaborative Group Activity at the Interactive Whiteboard, *Computers and Education, 55*(1), 350-362.
- Wolfe & Alexander, (2008). Argumentation and dialogic teaching: alternative pedagogies for a changing world. *Beyond current horizons*.
Retrieved from: http://www.beyondcurrenthorizons.org.uk/wp-content/uploads/ch3_final_wolfealexander_argumentationalalternativepedagogies_20081218.pdf

FATİH PROJESİYLE İLGİLİ AMPİRİK ÇALIŞMALARIN ANALİZİ: BİR LİTERATÜR TARAMASI

THE ANALYSIS OF EMPIRICAL STUDIES RELATED TO FATİH PROJECT: A LITERATURE REVIEW

Fatih Süleyman BİÇER
Süleyman Demirel Üniversitesi
fatihssuleymanbicer@gmail.com.tr

Mustafa KOÇ
Süleyman Demirel Üniversitesi
mustafakoc@sdu.edu.tr

ÖZET: Bu çalışmanın amacı 2010 yılı Kasım ayından itibaren Milli Eğitim Bakanlığı tarafından yürütülmekte olan teknoloji entegrasyonu “FATİH Projesi” kapsamında yapılmış bilimsel araştırmaların taranması ve irdelenmesi yoluyla projede ulaşılan ilk çıktıları, etkileri, sorunları ve paydaş görüşlerini değerlendirmektir. Literatür taraması metodu kullanılarak ulusal ve uluslararası dergilerden, lisansüstü tez veritabanlarından ve internet arama motorlarından ilgili çalışmalara ulaşılmıştır. Yapılan taramalarda “FATİH projesi”, “bilgi teknolojileri”, “Tablet PC” ve “akıllı/etkileşimli tahta” gibi anahtar kelimeler kullanılmıştır. Araştırmalar 2011-2014 yılları arasında yayınlanmış olan güncel çalışmalarla sınırlandırılmıştır. Tarama sonucunda elde edilen bütün ampirik çalışmalar içerik analizi yöntemiyle ayrıntılı bir şekilde incelenmiş ve gözden geçirilmiştir. Araştırmalar, konuları ve örneklemelerindeki benzerlikler dikkate alınarak (a) öğretmenler ve (b) öğrenciler üzerine yapılan çalışmalar olmak üzere iki ana tema altında toplanmıştır. Sonuç olarak, yapılmış araştırmaların genellikle donanımsal araçların kullanımına yönelik tutum ve algıların ölçülmesine yönelik olduğu görülmektedir. İleriki çalışmalarda projenin yöntem, içerik ve süreci bakımından daha kapsamlı ele alınmasına ve projede dağıtılmış olan teknolojilerin öğrencilerin motivasyon, başarı ve düşünme becerileri gibi bilişsel ve duyuşsal çıktılar üzerinde etkilerinin araştırılmasına önem verilmesi önerilmiştir.

Anahtar sözcükler: FATİH Projesi, Tablet PC, Akıllı Tahta, Teknoloji Entegrasyonu, Literatür Taraması

ABSTRACT: The aim of this study is to evaluate first outputs, problems and stakeholder’s views reached in FATİH Project, a technology integration initiative carried out by Turkish Ministry of National Education since November, 2010. Literature review methodology was employed to obtain related research studies from both national and international journals, graduate thesis databases, and Internet search engines. Such keywords as “FATİH Project”, “Tablet PC”, and “Smartboard” were used in searching the literature. Since the project is relatively new, research studies were limited to those published from 2010 to beginning of 2014. A content analysis was conducted to deeply examine empirical studies gathered from the literature survey. Based on the similarities in their scopes and samples, the studies were categorized under two main themes as (a) research on students and (b) research on teachers. Overall, it was revealed that the studies conducted so far were devoted to measure mostly attitudes and perceptions about the use of hardware tools. The findings suggest that future studies should give priority to intensive examination of the method, content and process of the project as well as investigation of potential effects of technologies distributed within the project on students’ cognitive and affective characteristics such as motivation, achievement, and thinking skills.

Key words: FATİH Project, Tablet PC, Smart Board, Technology Integration, Literature Review

GİRİŞ

Dünyada gelişen teknoloji karşısında her alan gibi eğitimde kaçınılmaz bir değişimin içerisine girmiştir. Sanayi toplumundan bilgi toplumuna geçiş ve aynı zamanda teknolojideki sürekli gelişim, hayatın hemen her alanına yansımıştır. Teknolojinin günlük yaşantılarla bütünleşmesiyle birlikte dijital okur-yazarlık, dijital vatandaşlık, dijital uçurum, dijital yerlilik ve dijital göçmenlik gibi kavramlar toplum yaşantısında önem kazanmaya başlamıştır. Sürekli olarak gelişen ve bu gelişimle birlikte değişen dünyada bireylerin bu gelişmelere ayak uydurabilmesi, çağın beklentilerine cevap verip bunun yanında araştırıp, sorgulayan ve kendini gerçekleştirmiş, özgüven duygusu gelişmiş bireyler yetiştirmek ve davranışlarındaki değişiklikleri kalıcı hale getirebilmek ancak eğitimle mümkün olmaktadır (Akgün, Yılmaz ve Seferoğlu, 2011).

FATİH Projesi

Eğitim kurumları toplumsal gelişmeleri başlatan ve yönlendiren kurumlardan birisi olarak teknolojik gelişmeleri takip edip kullanmakla birlikte bu teknolojilerin kullanımını da öğretmek zorundadır (Akkoyunlu, 1995). Devlet politikası olarak ülkemizde okullarda bilgi ve iletişim teknolojileri (BİT) entegrasyonu uzun zamandır sürdürülmekte ve bu süreçte gelişim ve değişim yeni projelerle birlikte devam etmektedir. Milli Eğitim Bakanlığı (MEB) tarafından 2010 yılı Kasım ayında duyurulan Fırsatları Arttırma ve Teknolojiyi İyileştirme Hareketi (FATİH) projesi bunlardan birisidir. Projenin temel amacı okullardaki teknolojiyi iyileştirmek ve eğitim ve öğretimde fırsat eşitliğini sağlamaktır (MEB, 2014). Proje kapsamında okul öncesi, ilköğretim ve ortaöğretim düzeyindeki tüm dersliklere LCD panel etkileşimli tahta ve internet ağı alt yapısı sağlanarak BİT araçlarının öğrenme-öğretme sürecinde daha fazla duyu organına hitap edilecek şekilde, derslerde etkin kullanılması hedeflenmektedir. Ayrıca her öğretmen ve öğrenciye tablet bilgisayar dağıtılmasının yanı sıra öğretmenlere hizmet içi eğitimler verilecek ve öğretim programları BİT destekli öğretime uygun hale getirilerek eğitsel e- içerikler oluşturulacaktır (MEB, 2014). Proje (a) donanım ve yazılım altyapısı sağlanması, (b) eğitsel içeriklerin geliştirilmesi, (c) öğretim programlarında BİT kullanımı, (d) öğretmenlerin eğitimi ve (e) bilinçli, güvenli ve ölçülebilir BİT kullanımı şeklinde beş ana bileşenden oluşturulmuş ve beş yılda tamamlanacak şekilde planlanmıştır.

Projenin pilot okullarda başlamasıyla birlikte ilgili akademik ve bilimsel araştırmalarda ivme kazanmıştır. Bu çalışmalar projenin yürütülmesi sürecinde proje paydaşları (öğretmenler, öğrenciler, yöneticiler vb.) üzerinden veriler toplanarak projenin gidişatı, etkileri ve projeden beklentilerin belirlenmesinde önemli bir role sahiptir. Çalışmalardan elde edilen bulgular ve öneriler projenin biçimlendirici değerlendirilmesinde kullanılarak projeye yön vermede ve aksaklıkların giderilmesinde yürütücülere yardımcı olacaktır. Dolayısıyla bu çalışmanın amacı 2010 yılı Kasım ayından itibaren Milli Eğitim Bakanlığı tarafından yürütülen FATİH Projesi kapsamında yapılmış bilimsel araştırmaların taranması ve irdelenmesi yoluyla projede ulaşılan ilk çıktılar, etkileri, sorunları ve paydaş görüşlerini değerlendirmektir.

YÖNTEM

Çalışma önceki araştırmaların incelenmesini kapsayan literatür taraması şeklinde desenlenmiştir. Ulusal ve uluslararası dergilerden, Yükseköğretim Kurulu (YÖK) lisansüstü tez veri tabanından ve Google arama motorundan yararlanılarak kapsamlı bir yayın araması yapılmıştır. Elektronik ortamlarda yapılan taramalarda “FATİH projesi”, “bilgi teknolojileri”, “Tablet PC” ve “akıllı/etkileşimli tahta” gibi anahtar kelimeler kullanılmıştır. Proje başlangıç tarihi 2010 yılının Kasım ayı olduğu için araştırmalar 2011-2014 yılları arasında yayınlanmış olan güncel çalışmalarla sınırlandırılmıştır. Tarama sonucunda elde edilen bütün ampirik çalışmalar ayrıntılı bir şekilde incelenmiş ve gözden geçirilmiştir. Araştırmalar, konuları ve örneklemelerindeki benzerlikler dikkate alınarak (a) öğretmenler üzerine yapılan çalışmalar ve (b) öğrenciler üzerine yapılan çalışmalar olmak üzere iki ana tema altında toplanmıştır.

BULGULAR

Öğretmenler Üzerine Yapılan Çalışmalar

FATİH Projesi hakkında öğretmenler ile yapılan çalışmalar incelendiğinde BİT kullanımına yönelik bilgi, beceri ve duyuşsal yeterlikleri noktasında ortaya iki farklı sonuç çıktığı görülmektedir. Yapılan araştırmaların çoğunluğu öğretmen ve öğretmen adaylarının BİT kullanımına hazır veya yeterli olmadığı sonucuna ulaşırken (Akıncı, vd., 2012; Bulut ve Koçoğlu, 2012; Çiftçi vd., 2013; Dinçer, 2011; Dinçer vd., 2012; Gürol vd., 2012; Kayaduman vd., 2011; Korkmaz ve Aktürk, 2013; Tekedere, 2013; Türel, 2012), diğer araştırmalar BİT kullanımına kısmen de olsa hazır ve yeterli düzeyde olduklarını belirtmektedir (Oktay ve Çakır, 2012; Tekerek vd., 2012).

Türel'in (2012) İstanbul ili Anadolu Yakası'ndaki çeşitli ilköğretim okullarının orta düzeyinde (6, 7 ve 8. sınıflar) farklı dallarda ders vermekte olan 210 öğretmenin katıldığı çalışmada, öğretmenlerin teknik bilgi eksikliği, içerik yetersizliği ve teknik sorunlar nedeniyle akıllı tahtaları kullanamadıkları sonucu ortaya çıkmıştır. Yine benzer bulguların ortaya çıktığı Adıgüzel ve arkadaşlarının (2011) yaptığı çalışmada akıllı tahtaların kullanımı için öğretmenlerin daha kapsamlı bir eğitim almaları gerektiğini vurgulamaktadır. Gürol ve arkadaşlarının (2012) Elazığ ili Merkez ilçede yer alan ilköğretim okullarında görev yapan sınıf öğretmenleri ile yapmış olduğu çalışmada da FATİH projesi hakkında öğretmenlerin olumlu düşündüklerini ama bilgi eksikliği ve yeterlilik gibi konuların problemleri olduğuna değinmişlerdir. Gök ve Yıldırım (2013) öğretmenlerin FATİH

projesi kapsamındaki teknolojilerin kendilerine sağlanmasında ve ihtiyaçlarının belirlenmesinde görüşlerinin alınmamasını bu teknolojileri kullanmada olumsuz bir etken olarak gördükleri bulgusuna ulaşmıştır.

Öğretmen adayları ile yapılan çalışmalarda da paralel bulgular elde edilmiştir. Örneğin, Dinçer'in (2011) Çukurova Üniversitesi Eğitim Fakültesi'nde öğrenim gören öğrencilerin örnekleme oluşturduğu çalışmada FATİH projesi hakkında olumlu görüş belirttikleri ama uygulama açısından kendilerini yetersiz buldukları sonucuna ulaşılmıştır. Yine Demire ve arkadaşlarının (2011) Selçuk Üniversitesi, Bilgisayar ve Öğretim Teknolojileri Eğitimi Bölümünde öğrenim görmekte olan öğretmen adayları kendilerini yetersiz bulduklarını, bilgi eksikliği ve teknik donanımdan kaynaklı problemler yaşadıkları ve FATİH Projesinin amacı ve kapsamı hakkında yeterli bilgiye sahip olmadıklarını belirtmişlerdir. Korkmaz ve Aktürk'ün (2013) Kilis 7 Aralık Üniversitesi Eğitim Fakültesi Sınıf Öğretmenliğinde okuyan 165 öğretmen adayı ile yaptığı çalışmada benzer bulgulara rastlanmıştır. Bilgisayarların öğretimde kullanılmasının gerekliliği, öğrenciye ve öğretmene sağladığı faydalar ve zararlar ile ilgili tutumlarına göre verilere bakıldığında, öğretmenliğe adım atacak öğretmen adaylarının halen düşük seviyede olduğu bulgusuna ulaşılmıştır.

Diğer taraftan öğretmen ve öğretmen adaylarının FATİH projesi kapsamında BİT kullanımına hazır ve yeterli olduğunu gösteren çalışmalara bakıldığında ise bu araştırmaların sınırlı sayıda olduğu görülmektedir. Tekerek ve arkadaşlarının (2012) Kahramanmaraş Sütçü İmam Üniversitesi Eğitim Fakültesi BÖTE bölümü ve İnönü Üniversitesi Eğitim Fakültesi BÖTE bölümü öğrencileri üzerinde yaptığı çalışmada öğretmen adaylarının proje kapsamındaki teknolojilere karşı tutum ve algı boyutunda olumlu cevap verdikleri görülmüştür. Oktay ve Çakır'ın (2012) Amasya ili Suluova ilçesinde devlete bağlı ilköğretim kurumlarında farklı dallarda görev yapan 222 öğretmen üzerinde yaptığı çalışmada yine benzer bulgulara ulaşılmıştır. Öğretmenlerin FATİH projesinde dağıtılmış teknolojilerin kullanımına karşı tutum ve algı boyutunda olumlu cevap verdikleri görülmüştür. Öğretmenlerin teknolojiyi benimsedikleri ama teknolojinin sürekli gelişme gösterdiği bir ortamda öğretmelere sürekli eğitimlerin verilmesi ve teknolojiyi yakından tanımaya yönelik çalışmaların artırılması ön görülmüştür.

Öğrenciler Üzerine Yapılan Çalışmalar

FATİH Projesinin kapsamı hakkında öğrenciler üzerinde yapılan ampirik çalışmalara bakıldığında; Sünkür ve arkadaşlarının (2011) Malatya ilindeki ilköğretim okullarında akıllı tahta uygulamalarından yararlanan II. kademe (6, 7 ve 8. sınıf) öğrencileri üzerinde yapmış olduğu çalışmada öğrencilerin akıllı tahtayı kullanmaları ile ilgili olumlu düşünce belirttikleri görülmüştür. Yine benzer sonuçlara Zengin ve arkadaşlarının (2011) 2010-2011 bahar yarıyılında Elazığ'da merkeze bağlı bir ilköğretim okulunun 6. Sınıf öğrencileriyle yapmış olduğu çalışmada akıllı tahta kullanımının BİT 'e karşı tutuma olumlu yönde katkı sağlamakla birlikte, başarıyı da arttırabileceği görüşüne vurgu yapılmıştır. Fakat algı ve tutum kavramlarının zamanla oluşmasından dolayı önümüzdeki yıllarda tekrar araştırma yapılmasının önemli olduğu belirtilmektedir. Ayrıca, Alanay ve Arkadaşlarının (2013) iki pilot lisede yaptıkları araştırmada öğrencilerin projeye hakkında olumlu bir yaklaşım sergilemesine karşın, yaşanan bir takım aksaklıkların (yazılımsal ve donanımsal), e- içeriklerin eksikliğinin ve öğretmenlerin teknoloji kullanımı konusundaki eksiklikleri, öğrencilerin proje hakkındaki düşüncelerini olumsuz olarak etkilediği görülmektedir.

Ağır ve Arkadaşlarının (2013) proje kapsamında 9-12. sınıf Coğrafya dersi için hazırlanan e-içerik ile ilgili yapmış olduğu çalışmada paralel bulgulara ulaşılmıştır. Öğrencilerin kazanım bazlı coğrafya videosu (etkileşimli tahtada öğretmen anlatımı ve bu anlatım esnasında 3 boyutlu animasyonlar, belgeseller, çeşitli orijinal çizimler, haritalar, animasyonlar vb.) hakkında oldukça olumlu düşündükleri, bu videoların öğrenmelerine kolaylaştıracağını, aldıkları eğitimin kalitesini arttıracığını, motivasyonlarını arttıracığını ve dersi daha ilgi çekici/eğlenceli kılacağını vb. düşündükleri kanısına ulaşılmıştır. Ayrıca öğrencilerin neredeyse tamamı kazanım tabanlı videoda yer alan pek çok nesnenin (3 boyutlu animasyon, akıllı tahta kullanımı vb.) yer almasını istemektedir. Öztürk ve Can'ın (2013) 2011-2012 eğitim-öğretim yılı İstanbul ili Gaziosmanpaşa ilçesinde bir devlet ilköğretim okulunun 5.sınıfında öğrenim gören öğrencilerle yapmış olduğu çalışmada e-kitapların kolay taşınabilmesi, herhangi bir zamanda rahatça okunabilmesi(durakta, otobüste, seyahat halinde vb.) ve e-kitap özelliklerinin(sesli okuma, yazıların büyütülmesi vb.) teknolojiyi benimsemelerine yardımcı olduğu bulgusuna ulaşılmıştır.

Öte yandan FATİH projesi kapsamında dağıtılmış BİT'lerin (Tablet PC, etkileşimli tahta vb.) nasıl ve ne düzeyde öğrenciler tarafından kullanıldığını araştıran çalışmalarda bulunmaktadır. Akbay ve Küçük'ün (2013) Kars ilinde FATİH projesi kapsamındaki pilot okullardan birinde öğrenim gören 9. sınıf düzeyindeki öğrenciler ile yapmış olduğu çalışmada, öğrencilerin tablet bilgisayarlarını e-kitap olarak genellikle evde sözel dersler için kullanıldığı bulgusuna ulaşılmıştır. Ayrıca öğrenciler sayısal derslerle ilgili e-materyallerin yetersiz olduğunu belirtmişlerdir. Pamuk ve arkadaşlarının (2013) FATİH projesi kapsamında 11 pilot okulda 918 öğrenci ile

yaptığı çalışmada benzer bulgulara ulaşılmıştır. Proje kapsamında dağıtılan tablet PC'lerin kullanım alanı bakımından sınırlı olduğu ve e-içerik bakımından yetersiz olduğu bulgusuna ulaşılmıştır.

SONUÇ

FATİH Projesi hakkında yapılan ampirik çalışmalara bakıldığında çalışmaların genelinde algı ve tutumu ölçen çalışmalar bulunmaktadır. Yapılan bu çalışmalarda ise FATİH Projesi kapsamında dağıtılan donanımsal araçların kullanımına karşı tutum ve algı ölçülerek yorum yapıldığı görülmektedir. Bulgular öğretmen boyutunda incelendiğinde öğretmenlerin genel olarak projeye olumlu baktıkları söylenebilir. Öğretmenlerin teknik bilgi ve beceri yetersizliği, e-içerik eksikliği ve teknik sorunlar projenin önünde bulunan öncelikli engeller olarak görülmektedir. Bu bağlamda, proje yürütücüsü ve paydaş kurumların öğretmenlerin sıkıntı yaşadıkları ve kendilerini yetersiz bulduğu alanlarda destek verebilecek birimlerin kurulması ve eğitim programlarının geliştirilmesi üzerinde ivedilikle çalışılmalıdır. Örneğin, il genelinde kurulacak bir merkezde BİT ve alan/branş öğretmenlerinin uzmanlarla birlikte e-içerik geliştirerek projeye aktif katılımları sağlanabilir. Ayrıca proje kapsamındaki her okulda teknik personel istihdam edilerek BİT öğretmenlerinin teknik iş ve sorumlulukları azaltılmalıdır. Böylece BİT öğretmenlerinin diğer branş öğretmenlerine yapacakları teknolojik rehberliği ve desteğini arttırılması sağlanmalıdır.

Öğrenci boyutundaki bulgular incelendiğinde ise öğrencilerin proje hakkında genel olarak oldukça olumlu düşündükleri görülmektedir. Hatta öğretmenlerden daha fazla ilgili ve istekli oldukları söylenebilir. Fakat öğrencilerin olumlu karşılamaşının projeden elde ettikleri kazanımlardan mı yoksa öğrencilerin yeni bir araç kullanmasına karşı merak uyandırmasından mı kaynaklı olduğunun araştırılması ve bu tür çalışmaların belirli periyotlar halinde tekrarlanması gerekmektedir. İncelenen çalışmalarda öğrencilerin dağıtılmış BİT'leri daha verimli kullanmaları için mevcut e-içeriklerin arttırılması sağlanmalıdır.

Alanyazın incelendiğinde şimdiye kadar yapılmış araştırmaların donanımsal araçların kullanımına yönelik tutum ve algıların ölçülmesine yönelik olduğu görülmektedir. Bundan sonraki çalışmaların projenin yöntem, içerik ve süreci bakımından daha kapsamlı ele alındığı çalışmalara önem verilmelidir. Ayrıca projede dağıtılmış ve kullanılması istenmiş olan BİT'lerin öğrencilerin motivasyon, başarı ve düşünme becerileri gibi bilişsel ve duyuşsal çıktılar üzerinde etkilerinin araştırıldığı deneysel ve boylamsal çalışmalar yapılmalıdır.

KAYNAKLAR

- Adıgüzel, T., Gürbulak, N., & Sarıçayır, S. (2011). Akıllı tahtalar ve öğretim uygulamaları. *Mustafa Kemal Üniversitesi Sosyal Bilimler Enstitüsü Dergisi*, 8(15), 457-471.
- Ağır, A., Polat, E., & Hopcan, S. (2013). *Fatih projesi e-içerik: 9.-12. sınıf kazanım bazlı Coğrafya videolarına ilişkin öğrenci görüşleri*. 7th International Computer & Instructional Technologies Symposium, Atatürk Üniversitesi, Erzurum.
- Akbay, M., & Küçük, S. (2013). *Ortaöğretim öğrencilerinin e-kitap kullanımına yönelik görüşleri*. VII. Uluslararası Bilgisayar ve Öğretim Teknolojileri Sempozyumu, Erzurum, Türkiye.
- Akgün, E., Yılmaz, E. O., & Seferoğlu, S. S. (2011). *Vizyon 2023 strateji belgesi ve fırsatları artırma ve teknolojiyi iyileştirme hareketi (FATİH) projesi: Karşılaştırmalı bir inceleme*. XIII. Akademik Bilişim Konferansı (AB11).
- Akıncı, A., Kurtoğlu, M., ve Seferoğlu, S.S. (2012). *Bir teknoloji politikası olarak Fatih Projesi'nin başarı olması için yapılması gerekenler: Bir durum analizi çalışması*. Akademik Bilişim Konferansı (AB12).
- Alanay, H., Gürol, M., Aydın, H. (2013). *Fatih Projesi Kapsamındaki Pilot Okul Öğrencilerinin Proje Hakkındaki Tutumları*. VII. Uluslararası Bilgisayar ve Öğretim Teknolojileri Sempozyumu, Erzurum, Türkiye.
- Bulut, İ., ve Koçoğlu, E. (2012). *Sosyal bilgiler öğretmenlerinin akıllı tahta kullanımına ilişkin görüşleri (Diyarbakır ili örneği)*. Dicle Üniversitesi Ziya Gökalp Eğitim Fakültesi Dergisi, 19, 242-258
- Çiftçi, S., Taşkaya, S. M., & Alemdar, M. (2013). Sınıf öğretmenlerinin FATİH Projesine ilişkin görüşleri. *İlköğretim Online*, 12(1), 227-240.
- Demirer, V., Saban, A., Küçük, Ş., & Şahin, İ. (2011). *Bilişim teknolojileri öğretmen adaylarının fatih projesi hakkındaki görüşlerinin değerlendirilmesi*. 11th International Educational Technology (IETC2011), İstanbul.
- Dinçer, S. (2011). *Öğretmen yetiştiren kurumlardaki öğrencilerinin öğrenim hayatları boyunca bilgisayar öğrenme düzeylerinin ve bilgisayar okuryazarlıklarının incelenmesi*. Akademik Bilişim Konferansı (AB11).
- Dinçer, S., Kutlar, N., Kaleci, D., & Kıran, H. (2012). *İlköğretim öğrencilerinin bilgisayar okuryazarlık düzeyleri ve bilgisayar derslerine karşı tutumları*. Akademik Bilişim Konferansı (AB12).

- Gök, A., Yıldırım, Z. (2013). *Fatih projesi kapsamındaki pilot okul öğrencilerinin proje hakkındaki tutumları*. VII. Uluslararası Bilgisayar ve Öğretim Teknolojileri Sempozyumu, Erzurum, Türkiye.
- Gürol, M., Donmuş, V., ve Arslan, M. (2012). İlköğretim kademesinde görev yapan sınıf öğretmenlerinin Fatih Projesi ile ilgili görüşleri. *Eğitim Teknolojileri Araştırmaları Dergisi*, 3(3).
- Kayaduman, H., Sırakaya, M., & Seferoğlu, S. S. (2011). *Eğitimde FATİH projesinin öğretmenlerin yeterlik durumları açısından incelenmesi*. Akademik Bilişim Konferansı (AB11).
- Zengin, F. K., Kırılmazkaya, G., & Keçeci, G. (2012). Akıllı tahta kullanımının fen ve teknoloji dersindeki başarı ve tutuma etkisi. *e-Journal of New World Sciences Academy (NWSA)*, 7(2).
- Korkmaz, A., Aktürk, A. (2013). *Fatih Projesi Sürecinde Sınıf Öğretmeni Adaylarının Bilgisayara Yönelik Tutumlarının İncelenmesi: Kilis 7 Aralık Üniversitesi Örneği*. VII. Uluslararası Bilgisayar ve Öğretim Teknolojileri Sempozyumu, Erzurum, Türkiye.
- Milli Eğitim Bakanlığı (2014). Eğitimde FATİH Projesi. [Çevrim-içi: <http://fatihprojesi.meb.gov.tr/tr/index.php>], Erişim tarihi: 01.01.2014.
- Oktay, S., ve Çakır, R. (2012). *İlköğretim öğretmenlerinin teknoloji kullanımları ve teknolojiye yönelik tutumları arasındaki ilişkinin incelenmesi*. X. Ulusal Fen Bilimleri ve Matematik Eğitimi Kongresi, Niğde, Türkiye.
- Öztürk, E., & Can, I. (2013). İlköğretim 5. Sınıf Öğrencilerinin Elektronik Kitap Okumaya İlişkin Görüşleri. *Türkiye Sosyal Araştırmalar Dergisi*, 171, 137-153.
- Pamuk, S., Çakır, R., Yılmaz, H. B., Ergun, M., & Ayas, C. (2013). Öğretmen ve Öğrenci Bakış Açısıyla Tablet PC ve Etkileşimli Tahta Kullanımı: FATİH Projesi Değerlendirmesi. *Kuram ve Uygulamada Eğitim Bilimleri*, 1-24.
- Sünkür, M., Arabacı, İ.B., ve Şanlı, Ö., (2012). Akıllı tahta uygulamaları konusunda ilköğretim II. kademe öğrencilerinin görüşleri (Malatya ili örneği). *E-Journal Of New World Sciences Academy (NWSA)*,7(1).
- Tekedere, H. (2013). *Öğretmenlerin Fatih Projesine Yönelik Görüş ve Önerileri*. VII. Uluslararası Bilgisayar ve Öğretim Teknolojileri Sempozyumu, Erzurum, Türkiye.
- Tekerek, M., Ercan, O., Udum, M. S., & Saman, K. (2012). Bilişim teknolojileri öğretmen adaylarının bilgisayar öz-yeterlikleri. *Turkish Journal of*, 1(2).
- Türel, Y. K. (2012). Öğretmenlerin akıllı tahta kullanımına yönelik olumsuz tutumları: Problemler ve ihtiyaçlar. *İlköğretim Online*, 11(2), 423-439.

ADAPTATION OF TECHNOLOGICAL PEDAGOGICAL CONTENT KNOWLEDGE (TPACK) AND TECHNOLOGY INTEGRATION SELF-EFFICACY SCALE (TISE) INTO TURKISH

Changes in technology directly affect educational process. Integration of technology into teaching and learning process is considered an important part of today's learning. In particular, teachers' role in the adaptation of technology into education and instruction is crucial. Teachers are responsible for preparing technologically literate students in the technology era. In order to achieve this, teachers should be technologically literate and integrate their technology, pedagogy and content knowledge (TPACK) into their instruction. Technology principle of National Council of Teachers Mathematics (2000) also emphasizes the role of teachers in technology integration because the effective use of technology in mathematics depends on knowledge and technological skills of mathematics teachers. However, technology knowledge is not enough. Teachers should make a decision about when and how to use technology in instruction effectively. In Turkey, there are some attempts to integrate technology into mathematics such as FATİH project.

Although the importance and necessity of technological pedagogical and content knowledge (TPACK) are emphasized, there is currently no comprehensive survey to evaluate TPACK. Moreover, to integrate technology into their pedagogy and curriculum successfully, teachers must develop confidence in their abilities to integrate technology in the classroom because the integration of technology affects how much students learn in the classroom (Bunch et al., 2012b). So, the aim of the study is adaptation of the TPACK scale which was developed by Handal et al. (2013) and TISE scale developed by Wang et al. (2004) to Turkish. The former instrument consists of 30 items and three dimensions: TCK, TPK and TPCK. The latter scale included 21 items. In order to adapt the scales, firstly scale items were translated to Turkish by the researchers. Then, translation form was further modified by specialists. Also, back translation was done by experts. English and Turkish forms of scale were both filled by pre-service secondary mathematics teachers in education. Turkish version of the scale was applied the same group after 4 weeks. After that, the data was analyzed by using SPSS. In this paper, the results of the pilot study which is the first part of more comprehensive study will be presented.

THE DERIVATIVE GRAPHS WITH NUMERIC AND GRAPHICS APPROACH

Jose CARLOS

Cortes ZAVALA

Several researchers point to the importance of introducing the concept of rate of change as a bridge to reach the intuitive concept of derivative . Based on this initial idea design and software development , which we called "Functions and Derivatives " . The proposed software activities that highlight difference, increments , and rationale increments aspects first with a numerical approach and subsequently using graphical approaches highlight visual ideas involving numerical - graphical relationship is incorporated .

The numerical and graphic treatment is rarely used and when it is only serves as an introduction without a proper connection to the algebraic process. Proposals such as Duval (1988.1993 and 1995) , withFry (1993) , Scher (1993) , Mejia (1997) , Hitt (2002) and Pluinage (2005) mention the importance it has for the learner , the graph management and numeric. Numeric , graphic and algebraic aspects are representations of mathematical objects and each presents certain information object also allow certain types of cognitive activities in the subject. When only one type of representation is used there is a risk , as mentioned by Duval (1988) , to confuse the object representation , so as methodology, this research proposes the use of multiple representations of an object.

Each representation leaves visible types of information, but also hides another and each of them allows us to perform certain types of operations . Both textbooks and in classroom work , these representations are given partially concealing information that allows us to make the right connections ; Taking into account the above is that we propose the construction of the graph starting from the numerical , but emphasizing that there is hidden information in such numerical representation

Keywords: differences, ration of increments, derivative function

DEVELOPING INNOMATTS TO IMPROVE MATHEMATICS TEACHERS' PEDAGOGICAL AND PROFESSIONAL COMPETENCES: AN INDONESIAN PERSPECTIVE

Mohammad ASIKIN

Mathematics Department of Semarang State University Indonesia
mohammad_asikin@yahoo.com

Iwan JUNAEDI

Mathematics Department of Semarang State University Indonesia
iwanjunmat@gmail.com

ABSTRACT: This project proposes an integrated model of mathematics teacher training which is developed based on the real need and potential of Indonesian mathematics teachers in improving mathematics learning. The main objective of this research is to develop the training model called INNOMATTS which has characteristics of independency, innovative, sustainable and problem solver in providing wider chance for mathematics teachers to improve their pedagogical and professional competences. This study employs R&D design using 10 steps of development model of Gall. This article describes the result of exploration study, model validation and practical testing. A sample of 30 mathematics teachers from various schools joined the INNOMATTS and were tested of pedagogical and professional competences. The results indicate that INNOMATTS is a promising training model for mathematics teachers' improvement in pedagogical and professional competences.

Key words: professional development, mathematics teacher training model, INNOMATTS model

INTRODUCTION

Teacher as a profession needs to be developed through several training methods. We see teacher as the one who organize learning and determine the quality of students. That is why teachers should have high competences and excellent characters to run their duties (Kunandar, 2007:40). The government of Indonesia has imposed a certification program for professional teachers. Teachers who can perform well in teaching and have high competences in pedagogy, social, personality and professional would be awarded by a significant incentive.

In order to run the program, the government provides several programs of professional development such as in-service training. However, these efforts can not significantly impact the improvement of teachers' quality. There are two reasons of why the training can not improve the quality of the teachers. The first is because the training was not based on the real problem in the classrooms. It seems that the program saw teachers from various regions in the same capacity and equal background while most of them came to the training with the different problems. The second is in the level of teacher practice, the knowledge or skill they got from training is not implemented in their classrooms (Hendayana, 2007). This condition leads to the idea that teachers always need a sustainable training which provides follow up in order to make sure that the training can significantly impact toward the improvement of teaching practice.

This issue is strengthened by the result of Teacher Competence Test in 2012. This test was conducted by the Ministry of Education and Culture to evaluate the certification program and to know whether the program brought significant impact toward teachers competence. The participants of this test were all certified teachers and those who have participated in in-service training held by the government. The result is not too satisfying. Among 217,766 teachers joined this test, the national average score is 49,57 which is below expectation with the minimum score is 0 and, maximum score is 95 and deviation standard 11.41.

The result in Central Java and Semarang City suggests the same condition as shown in Table 1. From the table, we can learn that the certified teacher, even those who have joined in-service training, still can not perform optimally in pedagogy and professional competence. In mathematics education, for instance, there are a lot of skill that the mathematics teacher should master, some of which are skill of organizing the appropriate mathematics class, skill of conducting classroom action research, and skill of analyzing the students' learning result. Those skills have not optimally covered in the recent training conducted by government.

Table 1. The Result of Junior High School (JHS) Teacher Competence Test 2012

Score of UKG	Central Java	Semarang City	Semarang City (Mathematics Teacher of JHS)
Average score of pedagogy and professional	53,99	55,22	69,71
Maximum	90	82	91,2
Minimum	0	21	26,3
Average of pedagogy	14,72	14,91	55,41
Maximum of pedagogy	29	27	86,96
Minimum of pedagogy	0	2	8,7
Average of professional	39,28	40,31	70,48
Maximum of professional	70	63	94,74
Minimum of professional	0	15	29,82

Source: BPSDMK-PMP Ministry of Education and Culture 2012/info-ukg.kemendikbud.go.id

Several studies of mathematics instruction suggests that the mathematics teaching practices in Indonesia still have not promoted either the innovative learning or innovative assessment (Ardhana, 2005; Iswahyudi, 2010; Marsigit, 2007). Most of them caused by the lack of knowledge and willingness to conduct and to explore various innovative mathematics instruction. From that condition, professional competence of teachers, especially mathematics teachers, should be paid attention by conducting in-service training or on job training based on the root problems in the classrooms. The training shall also be feasible to conduct independently by the teacher association and shall not always depend on the government program.

Teachers always question about a 'what next' program after such training conducted. This question commonly happens because most of training end up by less application in the classrooms. This phenomenon suggests that such training should accommodate the feasibility and empowerment that lead to the sustainability of the problem. It can be understood that once the program ended without any follow up to guarantee the sustainability, then the skills will be lost and the knowledge will be forgotten. In another hand, one of the keywords of professionalism is the capability to apply innovative learning in order to increase the learning quality. Thus, any training for teachers would be meaningful if it also accommodates the innovative learning.

Now we have keywords of what kind of training that mathematics teachers demand. It is a training which have characteristics of independent, problem solver, innovative and gives sustainable impacts and wider chance for mathematics teachers to improve their competences. This article proposes INNOMATTS which stands for Innovative Mathematics Teaching Study. INNOMATTS training model is a model of professional development for mathematics teacher inspired by several professional development philosophies and has characteristics which are suitable with the grass-root problems of Indonesian mathematics teaching practice.

Research Problems

The problems of this research are: (1) what kind of professional development training that mathematics teachers demand? (2) is the INNOMATTS model valid based on experts appraisal? and (3) how does it engage the teachers to improve their practice?

Professional Development Training Model

The establishment of INNOMATTS inspired by various professional development training model ideas. Some of which are:

- (1) Pauline Roger Model;
It is believed that teachers need time to apply changes in their teaching and critically respond the changes. This process needs support from the mathematics education expert. In the end, if the changes positively impact the students' learning result, then the teachers' belief would also positively change, and conversely.
- (2) Problem Solving Cycle (PSC) Model;
PSC believes that mathematics teacher profession development needs a long sustainable program. An iteration of PSC consists of 3 integrated workshops which allow teachers to share their experience.
- (3) Lesson Study;
The idea of lesson study is collaboration in designing, observing, and reflecting the learning. There are 7 keywords in lesson study, namely profession development, learning analysis, collaboration, sustainable, collegial, mutual learning, and learning community.
- (4) RCC Model;

The structure of RCC consists of 2 components, namely collective meeting and assignment both at classroom and at home. The main activities in the collective meeting are structure variation, group meeting, class taping, assignment discussion, sharing, and designing the next learning.

(5) Guskey Model;

The purpose of this model is to understand the trend as dynamic changes in learning. The model suggests that teachers experience determine the instruction changes. Once teachers see that the changes they made in their learning positively impact the students learning result, then the teachers' paradigm will change, too.

Characteristics of High-quality Teacher Professional Development

Burns (2011) stated that the professional development of teachers should have characteristics as follows.

- (1) Be competency-based, focused on helping teachers develop the knowledge, skills, attitudes, and dispositions demonstrably shown to improve teaching;
- (2) Be based on an understanding of teachers' needs and of their work environments;
- (3) Focus on deepening teachers' content knowledge and pedagogical skills;
- (4) Model the exact behaviors teachers are supposed to employ in their own classrooms;
- (5) Include opportunities for practice, research, and reflection;
- (6) Use information related to student learning for teacher development;
- (7) Be embedded in educators' workplaces and take place during the school day;
- (8) Be sustained over time;
- (9) Be grounded in a sense of collegiality and collaboration among teachers and between teachers and principals to solve important problems related to teaching and learning;
- (10) Build professional learning communities (technical and social support provided by professional learning communities helps to overcome inertia of status quo and helps teachers make complex changes);
- (11) Build teacher leadership and distributed leadership;
- (12) Focus on a small number of student learning goals; and
- (13) Match adult learning processes to intended outcomes.

Furthermore, NCTE (2009) said that any effort to strengthen teachers' professional practice must equally respect them as professionals. This includes matters of training in content and approach, how trainings are announced and how they are implemented. Programmes must build on and strengthen the teacher's own identity as a professional teacher and in many cases also establish and nurture the linkage with the academic disciplines of their interest. Programmes that compromise on the professional identity of the teacher and his/her autonomy will be unsustainable in the long run, providing very little psychological motivation for teacher to internalize what they have been 'told' in their practice.

METHODS

The steps of research followed the R&D design of Gall (2007:571). There are 10 steps of research adapted from the Gall design, namely: (1) Theoretical analysis; (2) Management analysis of the training implementation; (3) Exploration study; (4) Designing hypothetical model; (5) Designing the philosophical ground, purposes, characteristics and principles of the model; (6) Designing the strategy of implementation; (7) Designing the devices; (8) Evaluation (validation, practical testing, and effectiveness); (9) Revision; and (10) Final product. While this article focus on the description of the result of exploration study, validation process, and practical implementation testing.

Exploration Study

Exploration study is the initial step of R&D. The main purpose is to collect information as a provision to develop INNOMATTS. The objects considered are: theoretical framework of teacher training model, mathematics learning theories, the description of the learning implementation, the description of mathematics teacher competences, factors influencing the mathematics learning, and the other supporting learning factors.

The participants of the exploration study are 40 mathematics teachers in Semarang Central Java Indonesia who join the mathematics teacher council in Semarang. They were asked about their perception toward professional development training that they have ever joined and toward INNOMATTS through questionnaire and interview. The study also explored phenomena of teachers and students activities by using observation sheet.

Validation of Hypothetical Model Design

The INNOMATTS hypothetical model is validated by using Delphi technique. The validation was conducted in two phases. Delphi technique is a way to get consensus among experts by using intuitive approach. This technique has two advantages, namely it can accommodate subjective opinion of each individual and enable the opinion expressed freely without any domination. The steps of validation process are: (1) preparation; (2) expert determination which consists of 3 academic experts (professors), 5 policy makers (school principals and assessors), and 10 teachers; (3) instrument development, (4) distribution; (5) data collection; and (6) analysis. The second phase was the follow up of the revision after the model was validated in the first phase.

Practical Implementation Testing

The INNOMATTS training model was being tested to train mathematics teachers in Semarang city. There were 30 teachers joined the training for 3 months. The teachers divided into 5 clusters, each cluster consists of 6 teachers. They were all required to produce lesson plan and implement the instruction in their classes in 4 meetings. In the beginning and the end of the training, the participants were assessed by using teacher assessment guidance from the Development Center of Teacher Profession Development of the Ministry of Education and Culture 2011. They were also tested by using Teacher Competence Test based on the guidance of mathematics teacher competence test 2013. The data was collected through direct observation and video taping. The competence is considered as good if they get score above 75.

RESULTS AND FINDINGS

The exploration study suggests the perception of mathematics teachers as shown in the table 2.

Table 2. The Contribution of Training toward the Improvement of Mathematics Teacher Competence

No.	Contribution	Percentage
1.	Motivation to join the training came from another party	72,5 %
2.	The suitability of training material toward the need of teachers	75%
3.	Experiencing the benefits of training	90%
4.	Demanding the innovative training based on the demand of the age	97,5%
5.	Demanding the character development training	97,5%
6.	Demanding the assistance of colleagues, supervisor, expert in improving teachers' competence	92,5%
7.	Joining training only if it is funded by central or regional government	60%
8.	Understanding the training principles joined	70%
9.	Understanding the training strategies joined	40%
10.	Understanding training model joined	37,5%
11.	Understanding training characteristics joined	37,5%

Based on the table above, it can be described that mathematics teachers in Semarang city need innovative training which answers their real problems. Before this research, they only joined training if there was government program which required them to join certain training. They also demand assistance from experts in improving their competences. The table also suggests that less than 50% of the training participants really understand the strategy, model and characteristics of the training they joined.

Table 3. Training Management in Improving Mathematics Teachers' Competences

No.	Contribution	Percentage
1.	Understanding the planning of the training	22,5%
2.	Understanding the consensus initial planning of the training	17,5%
3.	Understanding the purpose and target of the training	52,5%
4.	Understanding the supporting resources in the training	55%
5.	Understanding the way to analyze and identify activities or tasks to reach the target	45%
6.	Providing management activities and coordination in every level of responsibility	52,5%
7.	Evaluating the implementation of training	55%
8.	There is evaluation to see the impact of planning and result of training toward the related parties	55%
9.	There is evaluation process of training by giving comment about the suitability of result and expectation	57,5%
10.	There is a follow up program after the training	27,5%

From the table above, only 22,5% of mathematics teachers in Semarang understand the planning, only 52,5% who understand the purpose of the training, and only 27,5% who suggests that there is follow up program of the training they ever joined. The result of exploration study suggests that mathematics teachers need training which gives deeper understanding toward purpose, strategy, evaluation mechanism and management activities of the training. In addition, they also demand follow up of training.

INNOMATTS Training Model

INNOMATTS training model is a model of professional development for mathematics teacher and has characteristics which are suitable with the grass-root problems of Indonesian mathematics teaching practice.

The Philosophical Ground

The INNOMATTS training model also have philosophical foundation according to the condition of Indonesian mathematics instructions below.

- (1) There are 4 components that should be concerned in constructing teachers' mathematics knowledge, they are knowledge of content, general pedagogy, specific pedagogy, and contextual pedagogy.
- (2) Any professional development program for teachers should be based on the government policy.
- (3) Any professional development program for mathematics teachers should be based on the constructivist and innovative paradigm.
- (4) Any professional development program for mathematics teachers should support the trend of mathematics education, especially the implementation of the 2013 curriculum.
- (5) Any professional development program for mathematics teachers should accommodate the aspiration and needs of mathematics teachers. Thus, the program should be flexible and accommodative.
- (6) Any professional development program for mathematics teachers should be in a form of collegial training, instead of individual.

The purposes of INNOMATTS model training are:

- (1) To facilitate mathematics teachers in order to reach the required competences,
- (2) To facilitate mathematics teachers in order to conduct innovative learning,
- (3) To motivate mathematics teachers in order to keep committing to do the main duties as professional teacher,
- (4) To give chance for mathematics teachers to share ideas, to help each other, and to give feed back,
- (5) To increase the knowledge and skill of innovative learning, and
- (6) To raise the image and dignity of mathematics teacher profession as well as the pride and respect toward the profession.

The INNOMATTS in Action

Based on the philosophical foundations above, the INNOMATTS is developed by the following ideas.

- (1) The INNOMATTS can be initiated by policy maker (government), professional organization (teacher council), or teacher directly request to the regional council.

- (2) The initiator analyzes the need and problems of the teachers dealing with the improvement of teachers' competence.
- (3) The need analysis is then matched with the INNOMATTS.
- (4) The government/teacher council establishes a team to design the INNOMATTS training based on the need analysis in a form of in-service training.
- (5) The next is the in-service training in a group. The result of this step is the design of cluster activity in a form of lesson study.
- (6) Implementing the on-service training in a form of Do and See parts of lesson study. The implementation of *Do* and *See* in this *cluster* is done by team consisting of 5 - 6 teachers. Each team can do the activities in different schools.
- (7) The result of *Lesson Study* is then designed to be applied individually in teacher's own school.
- (8) The result of *See* process in each cluster is used as the review material to design the next *in-service* activities. This cycle ends until the end of the proposed program.

The action of INNOMATTS can be explained as follows. The input of the model is Junior High School mathematics teachers. Within the model, cyclic activities happen in the first circle within the small IN circle, the activities are: (1) explanation about INNOMATTS model, (2) sharing ideas about desire, hope and problems in classrooms (3) material presentation, (4) initial data collection of teacher competence, and (5) designing the ON activities. The ON activities is the implementation of what designed in the IN. ON activities conducted in the cluster to implement lesson study. After that, the cluster implement R activities which is reviewing the implementation of ON activities. The illustration about the IN, ON, and R activities can be seen in Figure 1.

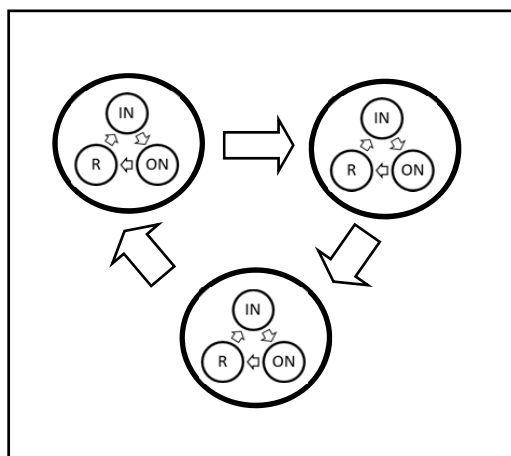

Figure 1. The IN, ON, and R cycles

From the figure above, there are three cycles of IN, ON, and R activities. In the second circle, what will happen in the IN, ON and R activities are the continued activities of the first circle, with IN is the designing, ON is the implementation and the R is the review activities.

In the third circle, we collect data of teacher competence in IN activities. After that, we collect data of students' learning result in each school, conducting interview with the principal, teachers and students in ON activities; and at last, we conduct R activities by reviewing the entire training activities and designing the follow up program.

In order to smoothen the implementation of INNOMATTS training model and to reach the training goals, we need several strategies as follows:

- (1) INNOMATTS training model can be implemented in a scheduled program within mathematics teacher association, or else, it can be conducted under the authority of education foundation or another teacher association.
- (2) INNOMATTS training model is designed and implemented in cyclic model (applying Deming cycle P-D-C-A/ *Plan-Do-Check-Act*).
- (3) The training activities conducted in a group based project or in an individual project.
- (4) The training provides expert advisor during the activities.

The structure of the INNOMATTS training program is shown in Table 4.

Table 4 The Structure of INNOMATTS

No	Subject	Theory (IN)	Practice (ON/ Cluster)	Practice (ON /Class)	Review (R)
A	GENERAL				
	Government policy about the curriculum and teacher professional development	3			
B	BASIC				
	1. The 2013 mathematics curriculum for JHS	6	2 x 3		
	2. Sustainable professional development for teacher	3			
	3. Brain storming about selected topics of mathematics teachers' need and problems	4	4 x 2		
	4. Mathematics learning theories	3			
	5. Innovative Learning Model and Approach in Mathematics (PBL/ problem based learning, PjBL/project based learning, RME/Realistic Mathematics Education, MEA/ Model Eliciting Activities, etc)	4	3 x 2	3x 2	4
	6. The use of ITC in mathematics learning	4	3 x 2		
	7. Lesson Study in mathematics learning	2	2 x 2		4
	8. Selected topics of comprehending the essential mathematics JHS material	6			
III	SUPPORT				
	1. Capacity Building	3			
	2. Follow up program	5			
IV	EVALUATION			6	

The Result of Validation

The validation process includes assessment toward the guidance of the implementation of INNOMATTS and the prediction of the result after the implementation of the training. Among the indicators, the percentage of item which is considered as good and very good (scored 3 and 4) is reaching 95%. Based on the validation, several recommendations addressed to revise the model as follows:

- (1) The innovation should be expressed clearly;
- (2) Evaluation after training shall be added;
- (3) Several detail such as table of content, layout, the use of symbols, the meaning of several pictures shall be clear;
- (4) The time allocation shall be wisely arrange and clear;
- (5) It is necessary to add the advanced material such as mathematics Olympiad material;
- (6) The monitoring and evaluation activities shall be well planned;
- (7) The senior teachers shall be involved;
- (8) The characteristics and steps shall be cleared

All the recommendation has been accommodated at above design by doing revision. Overall, the result of validation process suggests that among 34 indicators, they are considered as good and very good.

Furthermore, the result of Kruskal Wallis hypothesis testing shows that there is no difference assessment given by academic experts, policy makers, nor teachers. Below is the output of 3 independent samples testing of mean difference Kruskal Wallis.

Researcher formulated hypothesis as follows:

H_0 : There is no significant difference among academic experts, policy makers, nor teachers

H_1 : There is significant difference among academic experts, policy makers, or teachers

Then we got output as shown in Table 5, Table 6, and Table 7 respectively.

Table 5. Descriptive Statistics Kruskal Wallis SPSS Output

	N	Mean	Std. Deviation	Minimum	Maximum
Data	41	3.4002	.30673	2.91	3.97
Validator	41	2.44	.776	1	3

From the table, there are 41 validators engaged in this validation process which the result shown in detail in Table 6 and Table 7.

Table 6. Ranks of Kruskal-Wallis Test

Validator	N	Mean Rank
Data	1	23.00
	2	21.28
	3	20.34
Total	41	

Among 41 validators, 7 validators came from academic experts, 9 validators came from policy makers, and the rest came from teachers.

Table 7. Test Statistics^{a,b}

	Data
Chi-square	.276
df	2
Asymp. Sig.	.871

a. Kruskal Wallis Test

b. Grouping Variable: Validator

Based on Table 7, we gain *p value* of Kruskal Wallis is $0.871 > 0.05$. It means that the H_0 is accepted. This result suggests that there is no revision for instrument validation.

Practical Implementation Testing Result

The result of practical implementation of INNOMATTS training model is shown in Table 8.

Table 8. Practical Testing Result

Cluster	Lesson plan (1 – 4)	Implementation (0-100)	Assessment Before Training (0-100)	Assessment Training (0-100)	After	Competence Test
A	3.6	89	71	82		82
B	3.8	92	70	86		88
C	3.7	90	70	84		83
D	3.5	87	73	83		85
E	3.6	86	72	87		82

The result for each cluster shows that teachers improve their teaching and got their score of competence more than 75, which is good.

The Improvement of Pedagogical and Professional Competence

Teacher competence is defined as knowledge, skill, and behavior that shall be possessed, internalized, mastered, and actualized by teacher (Depdiknas, 2004:7). The pedagogical competence is the teachers' ability to understand their students and learning including: (1) wide perspective of learning foundation, (2) students understanding, (3) curriculum development, (4) planning of learning, (5) educated learning, (6) the use of information and computer technology, (7) evaluation, and (8) promoting students potential. While the professional competence is teachers' ability in mastering knowledge, technology, arts and culture in their field, including: (1) mastering the material based on curriculum, (2) mastering concepts related to their discipline, (3) application of concepts in life, (4) competing professionally in global context.

INNOMATTS is inspired by the principles of various models of professional development adapted with the need of Indonesian mathematics teachers. The principles of the implementation of INNOMATTS include:

- (1) Effective and efficient;
Mathematics teachers have chance and ability to see and discuss their teaching practice in intensive discussion by using the facilities in INNOMATTS. The parameter of effectiveness measured by the accomplishment of the goal of training, while the parameter of efficiency measured by the ability of the model to use and to empower all the supporting potential either human resources, equipment, or leadership in order to save the fund and time to reach the goal.
- (2) Problem solving oriented;
INNOMATTS is formulized based on the need of mathematics teachers in implementing their learning, thus it is supposed to be able to encounter the core problem of mathematics learning.
- (3) Easy to conduct;
The structure program of INNOMATTS is simple.
- (4) Innovative;
Though it is inspired by various model of teacher professional development, the essence of INNOMATTS training model is philosophically different with the other model of professional developments. The excellent characteristics is in the IN, ON, and R activities which gives wider chance for teachers to develop and to improve their practices. The innovation can also be seen through the program structure and the material which promotes the innovation in mathematics learning.

The Characteristics of INNOMATTS

Based on the INNOMATTS principles, we can describe the characteristics of the training model as follows. First, INNOMATTS is a problem solver training model. Before the program structure of INNOMATTS constructed, the initiator of the training conduct a need analysis which can identify the core problems faced by mathematics teachers. Once the problems have been identified, then the training program can be formulated.

Second, INNOMATTS is independent. It means that whether the government can fund or support the program or not, INNOMATTS can be initiated and conducted by teachers community at schools, foundation, or association.

Third, the structure and programs of INNOMATTS accommodate the trend and innovation in mathematics learning. Patel (2011) suggests that innovation in teaching mathematics can be diversified in terms of methods, pedagogic resources and mastery learning strategy. Thus the training structure is designed in a hierarchy cycles, starts from the classical meeting, cluster activities or individual practice in each school. It is supposed that after the training, teachers can master the skills such as designing and implementing innovative learning model, namely *problem based learning*, *project based learning*, *RME/Realistic Mathematics Education*, *MEA/ Model Eliciting Activities*, and so on.

The forth is sustainability. INNOMATTS provides post-training program as a follow up of the training.

CONCLUSION

From the analysis about characteristics and implementation above, we learn that: (1) Indonesian mathematics teachers demand on the sustainable training to develop their pedagogical and professional competences, (2) INNOMATTS training model is considered as valid based on theoretical framework by academic experts, (3) INNOMATTS can facilitate mathematics teachers to develop good practice in mathematics teaching and to improve their pedagogical and professional competences. Mathematics teachers get wider chance to design, discuss, and solve their problems in mathematics learning through cluster activities and collegial practice at schools. INNOMATTS can be an alternative training model which is excellent and feasible to be conducted independently through teacher association.

RECOMMENDATIONS

The INNOMATTS training model has been conceptualized and discussed through various teacher forum. Thus, it makes INNOMATTS a promising training program to improve the pedagogical and professional mathematics teachers. There are yet several questions which need to be addressed through further reasearch. We need more empirical evidence to claim the effectiveness of this model in order to accomplish the goal of Indonesian teacher professional development. Furthermore, we need to disseminate the model in order to spread the advantages and opportunities for mathematics teachers.

REFERENCES

- Ardhana, W., Kaluge, L., & Purwanto. (2005). Pembelajaran inovatif untuk pemahaman dalam belajar matematika dan sains di SD, SLTP, dan di SMU. *Research Report of Postgraduate Grant Batch 1 Second year*. Ministry of National Education: Directorate of Research and Community Service of Higher Education.
- Atweh, B. (1998). The Construction of Social Context of Mathematics Classroom: A Sociolinguistic Analysis. *Journal for Research in Mathematics Education*, 29(1), 63-82.
- Baroody, A. J. (1993). *Problem Solving, Reasoning, and Communicating*. New York: Macmillan Publishing.
- Beaton, A. E. (1996). *Mathematics Achievement in The Middle School Years*. Boston: TIMSS International Study Center.
- Beck, S., & Frederiksen, L. F. (2008). Teaching, leadership and school culture – from loose to tight couplings. *International Journal of Management in Education*, 2(1), 1-13.
- Brooks, J. G., & Brooks, M. G. (1993). *In search of understanding: The case for constructivist classrooms*. Virginia: Association for Supervision and Curriculum Development.
- Burns, M. (2011). *Distance Education for Teacher Training: Modes, Models, and Methods*. Washington, DC: Education Development Center, Inc.
- Butler, D., & Leahly, M. (2003). *The TeachNet Ireland Project as a Model for Professional Development for Teacher*. Dublin: St Patricks College of Education, Dublin City University.
- Carole, et. al. (2009). The Professional Development of Leaders and Teachers of Mathematics. *NCSM Spring Journal*.
- Cai, J., & Patricia. (2000). Fostering Mathematical Thinking through Multiple Solutions. *Mathematics Teaching in the Middle School*, 5(8). Retrieved 8 April 2001 from <http://www.nctm.org/mtms/2000/04/index.htm>.
- Cerbin, W., & Kopp, B. (2006). Lesson Study as a Model for Building Pedagogical Knowledge and Improving Teaching. *International Journal of Teaching and Learning in Higher Education*, 18(3), 250-257.
- Covington, L. M. (2007). Reforming Mathematics to Meet the Needs of Exceptional Learners. *NCSM Journal*.
- Depdiknas. (2008). *Project Operasional Manual Program "BERMUTU"*. Jakarta: Depdiknas.
- Ditjen PMPTK. (2010). *Panduan Penilaian Kinerja Guru*. Jakarta: Pusbangprodik.
- Ditjen PMPTK. (2010). *Pedoman Pengelolaan Pengembangan Keprofesian Berkelanjutan (PKB)*. Jakarta: Pusbangprodik.
- Gaible, E. & Burns, M. (2005). *Using Technology to Train Teacher*. Retrieved from infoDEV.
- Gorris, T. (1998). *Reforms in secondary mathematics education in the Netherland*. Retrieved 24 March 2001 from www.fiuu.nl/en/indexpublicaties.html.
- Gravemeijer, K. 1994. Educational Development and Developmental Research in Mathematics Education. *Journal for Research in Mathematics Education*, 25, 443-471.
- Hendayana, S. et. al. (2006). *Lesson Study: Pengalaman IMSTEP-JICA*. Bandung: UPI Press.
- Hull, T. (2007). Manager to Instructional Leader: Developing Teachers As Leaders. *NCSM Journal Winter*.
- James, K. (2005). Learner-Centered Teacher Leadership in Mathematics Education. *NCSM Journal Summer*.
- Jennifer, J. (2009). The Problem-Solving Cycle: A Model of Mathematics Professional Development. *NCTM Journal Spring*. Reston, VA: National Council of Teacher Mathematics.
- Jones, P., & Song, L. (2005). *Action research fellows at Towson University*. Retrieved 24 March 2001 from <http://www.nipissingu.ca/oar/PDFS/V832E.pdf>.
- Karim, M. A. (2006). Implementation of Lesson Study for Improving The Quality of Mathematics Instruction In Malang. *Tsukuba Journal of Educational Study in Mathematics*, 25.
- Kristin L. (2011). *Preparation of Effective Teachers in Mathematics*. USA: National Comprehensive Center for Teacher Quality.
- Ivan Tasić. (2011). *Management Theories In Education*. Paper in International Symposium Engineering Management and Competitiveness 2011 (EMC2011) Serbia.
- Lawson J. M. (2000). Knowledge Connectedness in Geometry Problem Solving. *Journal for Research in Mathematics Education*, 3(1), 27-43.
- Lesnick, A., & Cook-Sather, A. (2009). Building Civic Capacity on Campus Through a Radically Inclusive Teaching and Learning Initiative. *Innov High Educ*, 35, 3-17.
- Lewis, C., Perry, Rebecca, Hurd, & Jacqueline. (2004). A Deeper Look at Lesson Study. *Academic Search Premier*, 61(5).
- Lewis, C. (2002). Does lesson study have a future in the United States? *Nagoya Journal of the Education and Human Development*, 1, 1-23.
- Lie. (2010). *Cooperative Learning*. Jakarta: Grasindo.
- Mangkuprawira, S. (2007). *Manajemen Mutu Sumber Daya Manusia*. Bogor: PT Ghalia Indonesia.
- Mark, J., Gorman, J., & Johannah, N. (2009). Keeping Teacher Learning of Mathematics Central in Lesson Study. *NCSM Journal*, Spring 12(1), 3-11.

- Matthew G. J. (2007). Lessons From A University-K-12 Partnership: Five Strategies for Mathematics Professional Development. *NSCM Journal*.
- Morris, L. V. (2009). Leadership and the Future of Higher Education. *Innov High Educ*. No 35: 1-2
- National Council for Teacher Education. (2009). *Towards Preparing Professional and Humane Teacher*. New Delhi: NCTM.
- National Council of Teachers of Mathematics. (2000). *Principles and Standards for School Mathematics*. NCTM: Reston VA.
- National Council of Teachers of Mathematics. (2000). *Learning Mathematics For A New Century, 2000 Yearbook*. NCTM: Reston VA.
- Orey, M. (2009). *Model-Based Methods for Assessment, Learning, and Instruction: Innovative Educational Technology*. Chapter submitted for the 2009 Educational Media and Technology Yearbook. Florida: Greenwood Publishing Group.
- Pattanida, P. (2004). *School-Based Training for In-Service Teacher Development: A Strategy for the Success of Learning Reform in Thailand*. Paper in The Fourth Scrutinizing Committee of The Council Minister.
- Podhorsky, C. & Moore, V. (2006). *Issues in curriculum: Improving instructional practice through lesson study*. Retrieved 15 August 2007 from <http://www.lessonstudy.net>.
- Prendergast, M. (2002). *Action research: The improvement of student and teacher learning*. Retrieved from <http://educ.queensu.ca/~ar/reports/MP2002.htm>.
- Pugalee K., & David. (2001). Using Communication to Develop Students Mathematical Literacy. *Mathematics Teaching in The Middle School*, 6(5), 296-299.
- Richey, Nelson, & Jonassen, D. (Ed). (1996). Developmental Research. *Handbook of Research for Educational Communication and Technology*. New York: Macmillan Simon & Schuster.
- Seago, N. (2007). Fidelity and Adaptation of Professional Development Materials: Can They Co-Exist? *NCSM Journal*.
- Seegers, G & Gravemeijer, K. (1997). Implementation and Effect of Realistic Curricula. In Beishuizein, Gravemeijer & van Leishout (Eds.). *The Role Of Contexts and Models in The Development of Mathematical Strategies and Procedures*. CD-β Series On Research And Mathematics Education. Freudenthal Institute Utrecht Netherland.
- Silver, A. E., & Smith, S. M. (1996). Building Discourse Communities in Mathematics Classroom. *1996Yearbook*. NCTM: Reston VA.
- Sullivan, P. (2011). *Teaching Mathematics: Using research-informed strategies*. Australian Education Review. Australian Council for Educational Research.
- Takahashi, A., Watanabe, T., & Yoshida, M. (2001). *Developing Good Mathematics Teaching Practice through Lesson Study: A US Perspective*. Retrieved 5 June 2012 from www.apectened.org/resources/downloads/takahashi.pdf.
- Taylor, E.V. (2011). Supporting children's mathematical understanding: professional development focused on out-of-school practices. *Journal Math Teacher Education*. doi: 10.1007/s/10857-011-9187-7.
- UNESCO. (1998). *Education For the Twenty-first century: issues and prospects*. Unesco Publishing.
- Van-den Akker, & Plomp, T. (1993). *Development Research in Curriculum: Propositions and Experiences*. Netherlands: University of Twente.
- Van-den Akker, Nieveen, & Plomp, T. (Eds). (2000). *Design and Development Methodology in Education*. Dodrecht: Kluwer Academic Pub.
- Verschafel, L. & De Corte, E. (1997). Teaching Realistics Mathematical Modeling in the Elementary School: A Teaching Experiment with Fifth Graders. *Journal for Research in Mathematics*, 28(5), 577-601.
- Zawojewski, J.S, Robinson, M, & Hoover, M. (1999). Reflections on Developing Mathematics and the Connected Mathematics Project. *Journal for Mathematics Teaching in the Middle School*, 4, 324-330.

STUDENTS' PERCEPTIONS TOWARDS CONCEPTS OF DOMAIN, CODOMAIN AND IMAGE OF DOMAIN

Tuğba HANGÜL

İlyas YAVUZ

The purpose of this study is to identify undergraduates' perceptions of domain, codomain and image of domain of functions and their preferences in using different representations of the function concept. To do this, an open ended questionnaire linked to the function concept was asked to 77 first graders at a university during the fall semester of the 2013-2014 academic year . In this paper, only results of the analysis of students' answers to one question is presented. The results of this study revealed that students preferred verbal, diagram, graph and numerical representations of functions. In addition, it was seen that students had lack of knowledge about the concept of function and classification of numbers as well as had problems translating among multiple representations of the function concept and using of mathematical language correctly.

Keywords: Multiple representations, codomain, function concept, image of domain, domain

İLKOKUL 4.SINIF MADDEYİ TANIYALIM ÜNİTESİNE YÖNELİK BİR BAŞARI TESTİ GELİŞTİRME ÇALIŞMASI

Menşure ALKIŞ KÜÇÜKAYDIN
TOKAT MEM/Amasya Üniversitesi Sosyal Bilimler Enstitüsü Doktora Öğrencisi
mensurealkis@hotmail.com

Doç.Dr. Sevilay KARAMUSTAFAOĞLU
Amasya Üniversitesi Eğitim Fakültesi İlköğretim Bölümü
sevilayt2000@yahoo.com

Doç.Dr. Şafak ULUÇINAR SAĞIR
Amasya Üniversitesi Eğitim Fakültesi İlköğretim Bölümü
safak.ulucinar@amasya.edu.tr

ÖZET: Çalışmanın amacı, ilkokul dördüncü sınıf fen programında bulunan “Maddeyi Tanıyalım” ünitesine yönelik öğretmenlerin öğretim sürecinde ve araştırmacıların çalışmalarında yararlanabilecekleri geçerli ve güvenilir çoktan seçmeli bir ölçme aracı geliştirmektir. Bu doğrultuda üniteye mevcut kazanımlar Bloom Taksonomisi’ne göre analiz edilmiş, yetersiz olduğu düşünülen bazı kazanımlar eklenerek, bu kazanımları ölçecek çoktan seçmeli dört seçenekten oluşan 30 soruluk Maddeyi Tanıyalım Başarı Testi (MTBT) hazırlanmıştır. İlgili kazanımların ve soruların belirtke tablosu düzenlenerek alan eğitimi uzmanlarına ve konu alanı öğretmenlerine sunulmuş ve onların görüşleri doğrultusunda kapsam geçerliği sağlanmıştır. Bundan sonra pilot çalışması yapılarak, teste son hali verilmiştir. Test 200 öğrenciye uygulanmıştır. Uygulama sonrasında her bir maddenin madde güçlüğü, madde ayırt ediciliği, standart sapma, aritmetik ortalama, varyans gibi değerler hesaplanmıştır. Bununla birlikte yapılan diğer hesaplamalarla KR 20 güvenirlik katsayı 0,89; KR 21 değeri 0,88 olarak bulunmuştur. Madde analizi ile testin ortalama madde güçlük ve ayırt edicilik endeksleri sırasıyla 0,51 ve 0,40 olarak hesaplanmıştır. Araştırmanın sonunda ilkokul 4. Sınıf düzeyinde Maddeyi Tanıyalım ünitesine yönelik öğretmenlerin ve araştırmacıların kullanabileceği geçerli ve güvenilir bir ölçme geliştirilmiştir. Araştırmanın yürütme sürecinde karşılaşılan durumlarla ilgili bazı önerilerde bulunulmuştur.

Anahtar Kelimeler: Başarı Testi, Geçerlik, Güvenirlik, Maddeyi Tanıyalım

ABSTRACT: The aim of this study is to develop a reliable and valid measurement tool for primary school 4th graders by taking the course "Properties of Matter" as the basis. For this purpose, the questions were prepared according to the achievements gained in the course together with the gains aimed. The questions prepared were presented to expert opinions first, and then the table of specifications of the test was created. After the pilot study, the final test was applied to 200 students. After the application of each item difficulty, item to distinguish the spur, the standard deviation is the arithmetic mean, the variance calculated values such as. The KR 20 reliability coefficient of the test results was found as 0.89, and the KR 21 value was 0.88. And the item analysis revealed the average item difficulty and differentiation indexes as 0.51 and 0.40, respectively. At the end of primary school survey 4 th the class level, getting to know the unit, use the current teachers and researchers for the item, and developed a reliable measurement. Based on the results obtained, we have made certain proposals.

Keywords: Achievement Test, Validity, Reliability, Properties of Matter

GİRİŞ

Gelişmiş veya gelişmeyi hedefleyen her ülke, mevcut eğitim sisteminin kalitesini ölçme ve değerlendirme işlemleriyle gerçekleştirir. Değerlendirme sonuçlarına dayanarak mevcut eğitim sistemini devam ettirme ya da reform yapma gerekliliğine odaklanır. Dolayısıyla değerlendirmenin amacı ve rolü daima öncelikli bir konu olmuştur. Resmi eğitim programı sorumluları ya da değerlendirme uzmanları her yıl yeni bir eğitim programı konusu geliştirmezler ama öğretmenler daima öğrencilerine mevcut programı sunmak için yeni yollar denerler. Bu nedenle öğrenciler aslında sürekli bir biçimde öğretim programı deneyimi yaşarlar. Bu deneyim veya değişiklikler oldukça ufaktır ve değişik eğitici rutinler içerir. Fakat aynı zamanda yapılan resmi öğretim programı değişimlerinden de çok etkili olabilir (Orpwood, 2001). Dolayısıyla sınıf ortamında öğretmen

tarafından verilen bilgilerin öğrenciler tarafından ne düzeyde öğrenildiği ancak geçerlilik ve güvenilirliği sağlanmış ölçme araçlarıyla yapılabilir (Gönen, Karakaya ve Kocakaya, 2011). Bu anlamda başarı durumlarının ölçülmesi ve değerlendirilmesine ihtiyaç hissedilen konu veya ünitelerde bir takım ölçme araçlarının kullanılması yoluna başvurulur. Araştırmacıların genel olarak öğretmenlere tavsiye ettikleri değerlendirme biçimi formative (süreç) değerlendirme ve summative (erişi) değerlendirme değildir. Ancak bu şekilde öğrenci öğrenmeleri üzerinde geri bildirimler sağlanabilir. Daha etkili olduğu düşünülen metotlar, öğretmenin yaratıcılığı için pratikte daha az kalabalık bir sınıf ortamı gerektirir ve bu metotlar çok fazla zaman alırlar (Treagust, 2006). Bu durumda klasik bir ölçme aracı olarak karşımıza çoktan seçmeli testlerin çıktığını görmekteyiz. Test sonuçlarının puanlanmasının kolay olması, konu alanı bilgisini ölçmede geniş bir alanı tarayabilmesi, öğrenci tarafından cevaplanmasında zaman kaybı olmaması, soru analizlerinin kolay olması, soruların amaca uygunluğunun ölçmede kolaylık tanınması gibi nedenlerin çoktan seçmeli testlerin kullanılma nedenleri olduğunu söylemek mümkündür (Bahar,2001). Mevcut eğitim sistemine bakıldığında bu anlamda yapılacak bir başarı testinin hemen her alanda bir ihtiyaç olduğu görülebilir. Özellikle Fen ve Teknoloji alanında yapılan testlerin genel amacı; bugüne kadar değinilmiş olan önemli olgu, kavram, ilke ve yasaları kapsayan dayanıklı bilgi birikimlerini ve gözlem veya deney yapma, düzenleme, yorumlama ve genellemeyi kapsayan verimli bilgi yollarını ölçmektir (Özçelik, 2013). Bu noktadan hareketle ilkökul 4.sınıf Fen ve Teknoloji dersi “Maddeyi Tanıyalım” ünitesi temel alınarak geçerlilik ve güvenilirliği hesaplanmış bir başarı testi geliştirme çalışması içine girilmiştir. Madde ve maddenin tanecikli yapısı, günlük hayatta pek çok olayın açıklanmasında kullanılan mikroskobik ve soyut özellikte bir konudur (Kaya, 2006:6). Pek çok eğitimci özellikle “maddenin yapısı” konusunu teorik kimyanın kalbi olduğu yönünde anlaşırlar. Çünkü maddenin yapısı pek çok bilim eğitimi programında, anaokulu yıllarından başlayarak ikinci kademedeki okulların çeşitli safhalarına kadar devam eden anahtar bir yapıya sahiptir. Ancak bilim öğrenme sürecinde öğrencilerin pek çok hata yaptığı ve kavram yanlışlarına sahip olduğu konu da yine madde ve yapısıdır. Tüm bu öneminden dolayı son otuz yılda maddenin doğası hakkında pek çok çalışma yapılmıştır (Özmen, 2011). Maddenin yapısı konusunda; ülkemizde ilköğretim öğrencilerinden başlanarak, öğretmen adaylarına kadar yapılan pek çok çalışma mevcuttur (Ayas ve Özmen, 2002; Nakiboğlu, 2001; Demircioğlu, Akdeniz ve Demircioğlu, 2004; Kavak, 2007; Eroğlu ve Öztuna Kaplan, 2010;Kocaarslan, 2012; Karaduman ve Emrahoğlu, 2011; Özalp ve Kahveci, 2011;Canbazoğlu ve Demrelli, 2010; Özmen, Ayas ve Coştu, 2002). Benzer biçimde yurt dışındaki alan yazı incelendiğinde de bu konuda yapılan çalışmalar dikkat çekmektedir (Gabel, Samuel ve Hunn, 1987; Novick ve Nussbaum, 1981; Novick ve Nussbaum, 1987; Dorothy, 1993; Brook, Briggs ve Driver, 1984;Valanides, 2000; Yezierski ve Birk, 2006). Ancak yapılan çalışmalar incelendiğinde madde ve yapısı ile ilgili olarak kavram yanlışları incelenmiş, tespit etme yoluna gidilmiş, bu yanlışları gidermek için öneriler sunulmuş ya da ünite öğretiminde farklı metotlar denenmiştir.

Bu çalışmada ilgili alan yazında ilkökul 4. Sınıf düzeyinde eksik olduğu düşünülen; test geliştirme basamakları dikkate alınarak ilkökul 4.sınıf öğrencilerinin “Maddeyi Tanıyalım” ünitesine yönelik geçerlik ve güvenilirlik çalışması yapılmış çoktan seçmeli bir başarı testi geliştirmek amaçlanmıştır.

YÖNTEM

Bu çalışmada test geliştirme basamakları dikkate alınarak, ilkökul 4. Sınıf seviyesinde Maddeyi Tanıyalım ünitesine yönelik 2005 Fen ve Teknoloji, 2013 Fen Bilimleri Öğretim Program’larında kullanılabilecek, öğrencilerin başarılarını ölçebilen bir test geliştirilmiştir. Soruların hazırlanması, kazanımların belirlenmesi gibi çalışma aşamalarında doküman analizi yönteminden yararlanılmıştır. Araştırmanın örneklemini 2013-2014 eğitim öğretim yılında Tokat ili ve ilçelerinde öğrenim gören toplam 200 ilkökul dördüncü sınıf öğrencisi oluşturmaktadır. Çalışmanın uygulandığı okullara göre öğrenci dağılımı Tablo 1’de gösterilmiştir.

Tablo 1. Öğrenci Sayılarının Okul ve Cinsiyete Göre Dağılımı

Okul Türü	Cinsiyet	
	Kadın	Erkek
İl merkezi	52	38
İl merkezine bağlı köy/kasaba	16	18
İlçe merkezi	15	20
İlçeye bağlı köy/kasaba	20	21
Toplam	103	97

Çalışmada ayrıca verilerin toplanması aşamasında geniş bir doküman analizi yapılmıştır.

MTBT’nin Geliştirilme Süreci

Maddeyi Tanıyalım Ünitesi Başarı Testi, araştırmacılar tarafından belirtilen ünitelerde öğrenci başarılarını ölçmek amacıyla geliştirildi. Test geliştirilmeden önce ilköğretim Fen ve Teknoloji dersi (4 ve 5.Sınıflar-2005) öğretim programı temel alınarak, belirtilen ünite ile ilgili kazanımlar ele alınmış, Bloom taksonomisinde yer alan bilişsel

düzelere göre sınıflandırılmıştır. Olması gerektiği düşünölen alanlarda bilişsel düzeyde kazanımlar eklenmiştir. Ünite ile ilgili belirtke tablosu oluşturularak, soru havuzu hazırlanmıştır. Sorular hazırlanırken, farklı yayınevine ait kitapçık ve testler, ders kitapları, elektronik kaynaklar ve daha önce yapılmış sınav sorularından yararlanılmıştır. Havuzda yer alan sorular üç tane Fen ve Teknoloji öğretmeni, daha önce derse girmiş dördüncü sınıf öğretmeni ve bu alanda ders veren öğretim üyelerine incelettirilerek kapsam geçerliği sağlanmıştır. Elde edilen taslak başarı testinde toplam 30 sorunun yer almasına karar verilmiştir.

Uygulama ve Veri Analizi

Kapsam geçerliği için uzman görüşü alınan ve belirtke tablosu oluşturulan soruların son şekli verilmeden önce pilot uygulaması yapılmıştır. Pilot uygulama sonucu elde edilen dönütlere göre soru köklerinde veya resimlemelerde bir takım değişiklikler yoluna gidilmiş ve 4 şıklı 30 soru içeren bir test oluşturulmuştur. Ardından son hâli verilen başarı testi toplam 200 öğrenciye uygulanmıştır. Puanlama 100 üzerinden yapılmış olup kusuratlđ ifadeler onluk yuvarlama hesabına göre tam sayı ifadelerine çevrilmiştir. Elde edilen veriler teker teker okunarak bir sınıflamaya tabii tutulmuştur. Buna göre elde edilen veriler düşük puandan yüksek puana göre sıralanmış ardından verilerin %27'si alt grup, %27'si üst grup olmak üzere iki gruba ayrılmıştır. Alt ve üst gruplardan elde edilen veriler dayanarak maddelerin ayırt edicilik ve güçlük dereceleri hesaplanmıştır. Buna göre ayırt ediciliđi 0, 25'in altında kalan iki soru testten çıkarılmıştır. Testten soruların çıkarılmasının ardından testin iç tutarlılığına yönelik olarak; arzulanan cevaplar verilmişse "1", yanlış veya boş bırakılmışsa "0" puan verilerek KR 20 ve KR 21 güvenilirlik hesaplamaları yapılmıştır.

BULGULAR

Hazırlanan başarı testi, uygulamadan sonra bir takım istatistikî çözümlemelere tabii tutulmuştur. Yapılan analizler sonucunda madde ayırt ediciliđinin 0,35 ile 0,70 arasında deđiştđi tespit edilmiştir. Ancak ayırt ediciliđi 0,25'in altında olan iki sorunun (12. ve 15.sorular) diđerleri kadar başarılı olmadığı görölmüştür. Dolayısıyla ayırt ediciliđi 0,25'in altında kalan soruların testten çıkarılması gerektiđine karar verilmiştir (Çepni, Bayrakçeken, Yılmaz, Yücel, Semerci, Köse, Sezgin, Demirciođlu ve Gündođdu,2008). Testten çıkartılan 12. madde dođal, işlenmiş ve yapay madde ile ilgili analiz düzeyinde bir soru olup ayırt ediciliđi düşük düzeyde bir sorudur. Testten çıkarılan diđer soru ise ısınma sođuma sürecinin ısı alış verişı ile gerçekteştiđi kazanımına dayanan deđerlendirme düzeyinde bir sorudur. Testin ortalama güçlük düzeyi 0, 51; ayırt ediciliđi ise 0,40'dır. Bu deđerlere bakarak testin nihai olarak amacına hizmet ettiđini söyleyebiliriz. Çoktan seçmeli bir test olması nedeniyle, başarı testi iç tutarlık hesaplamalarına tabii tutulmuştur. Testin 1-0 puanlama yapısında olması nedeniyle KR 20 ve KR 21 güvenilirlik katsayıları hesaplanmıştır. Buna göre KR 20 sonucu 0,89; KR 21 sonucu ise 0,88 olarak hesaplanmıştır. Genellikle ölçeklerde kabul gören güvenilirlik düzeyi 0,70 olarak tavsiye edilir (Tezbaşaran, 1996) dolayısıyla geliştirilen testin güvenilir ve amacına hizmet ettiđi söylenebilir. Aşađıda bu çalışmada elde edilen veriler özetlenmiştir.

Tablo 2. Başarı Testi İçin Elde Edilen İstatistikî Sonuçlar

	Başarı Testi Verileri
Soru Sayısı	30
Uygulanan Kişı Sayısı	200
Aritmetik Ortalama	15,905
Standart Sapma	6,95
Ortalama Madde Güçlüđü	0,51
Ortalama Ayırt Ediciliđi	0,40
KR 20 Deđeri	0,89
KR 21 Deđeri	0,88

Tablodan elde edilen verilere göre testin ortalama güçlüđü 0,51 ve ortalama ayırt ediciliđi ise 0,40'dır. Bu verilere göre testte kullanılan maddelerin iyi çalıştıđı söylenebilir. Testin iç tutarlılık katsayılarına bakıldığında ise testin güvenilir bir ölçme aracı olduđu görölmektedir. Testte ayırt ediciliđi yüksek ve çeldiricilerin işlerliğinin yüksek olduđu maddeler aşağıdaki tabloda sunulmuştur.

Tablo 3. Testte Yer Alan Çeldirici İşlerliğine Göre Madde Analizi

	Madde Güçlüđü En İyi Olan Madde (Madde No.4)	Madde Güçlüđü Düşük Olan Madde (Madde No.12)	Madde Ayırt Ediciliđi En Yüksek Olan Madde (Madde No.26)	Madde Ayırt Ediciliđi Düşük Olan Madde (Madde No.15)
Alt Grupta Çeldiriciye Yakalanma Oranı	%14	%68	%74	%83

Tabloya göre testten madde güçlük düzeyi oldukça düşük olan ($p=0,35$) ve madde ayırt edicilik oranı düşük olan ($d=0,07$) soruların çeldiricilerinin iyi işlemediği yani alt ve üst grupta çeldiricilere yakalanma oranlarının birbirine oldukça yakın oldukları görülmektedir.

SONUÇ VE ÖNERİLER

Bu çalışmada ilkököl 4.sınıf öğrencilerine yönelik olarak geçerlik ve güvenilirliği sağlanmış, madde analizleri yapılmış Maddenin Yapısı ünitesine yönelik bir başarı testi geliştirilmeye çalışılmıştır. Bunun için uzman görüşleri alınarak ve pilot uygulaması yapılarak test geliştirme süreci içine girilmiştir. Elde edilen sonuçlara dayanılarak bir takım yargılara ulaşılmıştır. Varılan sonuçlara dayanarak, hazırlanan başarı testinin ülke genelinde kullanılabileceğini söylemek mümkündür. Mevcut eğitim sistemine dayanarak çoktan seçmeli testlerin kullanıldığını ve bu uygulamanın uzun bir süre devam edeceğini söylemek yanlış olmayabilir. Dolayısıyla üzerinde çalışılmış ve geliştirilmiş bir başarı testine olan ihtiyacı yadsımak mümkün olmayabilir. Yapılan çalışmanın öğretmen ve uzmanlar için fayda getireceği ümit edilmektedir. Geliştirilmiş olan başarı testinden elde edilen verilere dayanarak araştırmacılar için bir takım öneriler aşağıda sunulmuştur.

1. Geliştirilen başarı testi uygulamaları esnasında erime ve çözünme konusunda ve karışımı oluşturan maddelerin saflık durumları ile ilgili bir takım kavram yanlışları tespit edilmiştir. Ancak tespit edilen kavram yanlışları giderilme yoluna başvurulmamıştır. Sonraki aşamada tespit edilen kavram yanlışlarını giderme çalışmaları hazırlanıp uygulanabilir.
2. Yapılan çalışma farklı sınıflarda ve farklı ünitelerde benzer biçimde örnek teşkil edebilir.
3. Hazırlanan çalışma belirlenen üniteye eksiklikleri görme ve giderme amacıyla da kullanılabilir.
4. Testte ayırt ediciliği ve madde güçlüğü düşük olan soruların düzeyleri incelendiğinde üst bilişsel düzeyde hazırlanan sorular olduğu görülmüştür. Bu noktadan hareketle özellikle üst grupta yer alan öğrencilerin çeldiricilere yakalanma oranlarının yüksekliği göz önüne alınıp, benzer düzeyde ve ilgili kazanımda farklı ölçme araçları uygulanarak maddenin neden yanlış cevaplandırıldığı tespit edilebilir.
5. Pilot uygulama esnasında öğrencilerin çok büyük bir kısmı tarafından ilgili sorularda yer alan “tortu, suni çim ve kâse” kelimelerinin anlamları sorulmuş ve uygulayıcı bu kelimelerin anlamları üzerinde açıklama yapmak durumunda kalmış, esas uygulamada farklı kelimeler kullanma yoluna gidilmiştir. Öğrenciler ders esnasında sadece ders kitaplarında yer alan örnekler üzerinden konu öğrenimi yapmakta, farklı kaynaklara yönelmemekte ve değişik örneklerle karşılaşmamaktadır. Bu duruma yönelik olarak öğrencilerin fen okur yazarlık düzeyleri ve fene karşı tutumları bu çalışma ile birlikte yürütülerek, aralarındaki ilişkiye bakılabilir.

KAYNAKLAR

- Ayas, A. ve Özmen, H. (2001) Lise Kimya Öğrencilerinin Maddenin Tanecikli Yapısı Kavramını Anlama Seviyelerine İlişkin Bir Çalışma, Boğaziçi Üniversitesi Eğitim Dergisi, 19 (2), 45-60.
- Bahar, M. (2001) Çoktan Seçmeli Testlere Eleştirel Bir Yaklaşım ve Alternatif Metotlar, Kuram ve Uygulamada Eğitim Bilimleri Dergisi, 1(1), 23-38.
- Brook, A., Briggs, H. ve Driver, R. (1984) Aspects of Secondary Students Understanding of The Particulate nature of Matter, Leeds Centre for Studies in Science and Mathematics Education University of Leeds.
- Canbazoglu, S., Demrelli, H. ve Kavak, N. (2010) Fen Bilgisi Öğretmen Adaylarının Maddenin Tanecikli Yapısı Ünitesine Ait Konu Alan Bilgileri İle Pedagojik Alan Bilgileri Arasındaki İlişkinin İncelemesi, İlköğretim Online, 9(1), 275-291.
- Çepni, S., Bayrakçeken, S., Yılmaz, A., Yücel, C., Semerci, Ç., Köse, E., Sezgin, F., Demircioğlu, G. ve Gündoğdu, K. (2008). *Ölçme ve Değerlendirme*. Ankara: Pegem Akademi
- Demircioğlu, H., Akdeniz, A.R. ve Demircioğlu, G. (2004) Maddenin Tanecikli Yapısına İlişkin Kavram Yanlışlarının Giderilmesinde Çalışma Yapraklarının Etkisi, XII. Eğitim Bilimleri Kongresi Gazi Eğitim Bilimleri Enstitüsü, 3, 2137-2160.
- Eroğlu, N. ve Öztuna, K.A. (2010) “6.Sınıf Maddenin Tanecikli Yapısı” Ünitesindeki Kavramların Öğretiminde Öğrenci Ürünü Karikatürlerin Kullanımı, IV. Ulusal Fen Bilimleri ve Matematik Eğitimi Kongresi.
- Gabel, D.L. (1993) Use of The particulate Nature of Matter in Developing Conceptual Understanding, Journal of Chemical Education, 70(3), 193-194.
- Gabel, L.D., Samuel, K.V ve Hunn, D. (1987) Understanding The Particulate Nature of Matter, Journal Of Chemical Education, 64(8), 695-697.
- Gönen, S., Kocakaya, S. ve Kocakaya, F. (2011) Dinamik Konusunda Geçerliliği ve Güvenirliği Sağlanmış Bir Başarı Testi Geliştirme Çalışması, Yüzüncü Yıl Üniversitesi Eğitim Fakültesi Dergisi, 8 (1), 40-57.

- Karaduman, B ve Emrahođlu, N.(2011) “Maddenin Tanecikli Yapısı” Ünitesinin Öğretiminde Bilgisayar Destekli ve Bilgisayar Temelli Öğretim Yöntemlerinin Akademik Başarı ve Kalıcılığa Etkisi, Kastamonu Üniversitesi Kastamonu Eğitim Fakültesi, 19(3), 929-938.
- Kavak, N. (2007) Maddenin Tanecikli Doğası Hakkında İlköğretim 7.Sınıf Öğrencilerinin İmaj Oluşturmalarına Rol Oynama Öğretim Yönteminin Etkisi, G.Ü.Gazi Eğitim Fakültesi Dergisi, 27(2), 327-339.
- Kaya, G. (2010) İlköğretim 6.Sınıf Fen ve Teknoloji Dersi Maddenin Tanecikli Yapısı Ünitesinin Didaktiksel Dönüşüm Teorisine Göre İncelenmesi, Yayınlanmamış Yüksek Lisans Tezi, Ondokuz Mayıs Üniversitesi, Samsun.
- Kocaarslan, M.(2012) Tanılayıcı Dallanmış Ağaç Tekniđi ve İlköğretim 5.Sınıf Fen ve Teknoloji Dersi Maddenin Deđişimi ve Tanınması Adlı Ünite de Kullanımı, Mustafa Kemal Üniversitesi Sosyal Bilimler Enstitüsü Dergisi, 9(18), 269-279.
- MEB (2005) İlköğretim Fen ve Teknoloji Dersi (4 ve 5.Sınıflar) Öğretim Programı Kılavuzu, Ankara.
- Nakibođlu, C. (2001) “Maddenin Yapısı” Ünitesinin İşbirlikli Öğrenme Yöntemi Kullanarak Kimya Öğretmen Adaylarına Öğretilmesinin Öğrenci Başarısına Etkisi, G.Ü.Gazi Eğitim Fakültesi Dergisi, 21(3), 131-143.
- Novick, S. ve Nussbaum, J.(1981) Pupils’ Understanding of The Particulate Nature Of Matter: A Cross Age Study, Science Education, 65(2), 187-196.
- Orpwood, G. (2001) Assessment in Education: Principles, Policy & Practice, Assessment in Education, 8 (2), 135-151.
- Özalp, D. ve Kahveci, A.(2011) Maddenin Tanecikli Yapısı İle İlgili İki Aşamalı Tanılatıcı Soruların Ontoloji Temelinde Geliştirilmesi, Milli Eğitim, 191, 135-156.
- Özçelik, D.A. (2013) Test Hazırlama Kılavuzu, Pegem Akademi, Ankara.
- Özmen, H.(2011) Turkish Primary Students’ Conceptions About The Particulate Nature Of Matter , International Journal Of Environmental and Science Education, 6 (1), 99-121.
- Özmen, H., Ayas, A. ve Coştu, B. (2002) Fen Bilgisi Öğretmen Adaylarının Maddenin Tanecikli Yapısı Hakkında Anlama Seviyelerinin ve Yanılgılarının Belirlenmesi, Kuram ve Uygulamada Eğitim Bilimleri, 2(2), 507-528.
- Tezbaşaran, A. A. (1996). Likert tipi ölçek geliştirme kılavuzu. Ankara: Türk Psikologlar Derneđi Yayınları.
- Treagust, D. F. (2006) Diagnostic Assessment in Science As a Means To İmproving Teaching, Learning and Retention, (science.uniserve.edu.au/pubs/.../treagust.pdf adresinden 01.12.2013 tarihinde indirilmiştir).
- Valanides, N.(2000) Primary Student Teachers Understanding of The particulate Nature of Matter and Its Transformations During Dissolving, Chemistry Education Research and Practice, 1, 249-262.
- Yeziarski, J.E. ve Birk, P.J.(2006) Misconceptions About The Particulate Nature of Matter: Using Animations to Close The Gender Gap, Journal of Chemical Education, 83(6),954-960.

SOME RESULTS ON CYCLIC CODES OVER $F_2 + uF_2 + vF_2 + uvF_2$

Murat GÜZELTEPE

Evren SALKIM

In this paper, we investigate the structure and properties of cyclic codes over the ring $F_2 + uF_2 + vF_2 + uvF_2$ where $u^2=u$, $v^2=v$ and $uv=vu$. We first study the relationship between cyclic codes over and binary cyclic codes. We prove that cyclic codes over the ring are principally generated, and give the generator polynomial of cyclic codes over this ring.

Keywords: Cyclic code, gray map, generator matrix, finite rings.

ZEKÂ OYUNLARI DERSİNE İLİŞKİN ÖĞRETMEN VE ÖĞRENCİ GÖRÜŞLERİ

TEACHERS' AND STUDENTS' PERSPECTIVE ABOUT MIND GAMES COURSES

Yasemin DEVECİOĞLU
Bayburt Üniversitesi Bayburt Eğitim Fakültesi İlköğretim Bölümü
ydevecioglu@bayburt.edu.tr

Zekeriya KARADAĞ
Bayburt Üniversitesi Bayburt Eğitim Fakültesi İlköğretim Bölümü
zekeriya@bilelim.net

Elif ÇELİK, Melda YILMAZ, Ünzile LEYLEK, Burçin DURDU
Bayburt Üniversitesi Bayburt Eğitim Fakültesi İlköğretim Bölümü

ÖZET: Bu çalışma, ülkemizde ortaokullarda yeni yürütülmeye başlayan Zeka Oyunları Dersi'nin(ZOD) ortaokullarda öğretmen ve öğrenciler tarafından nasıl karşılandığının belirlenmesi amacıyla yürütülmüştür. Tarama yönteminin kullanıldığı çalışmanın verileri, 2013-2014 Eğitim-Öğretim Yılı Güz Döneminde Bayburt il merkezindeki ortaokullardan elde edilmiştir. ZOD hakkında öğretmen, öğrenci ve idareci görüşlerini belirlemeye yönelik beş açık uçlu sorudan oluşan anket 133 öğrenci ve 15 öğretmen uygulanmıştır. Betimsel olarak analiz edilen anket verilerinde katılımcıların ZOD hakkındaki beklentileri, dersin amaçları, derste karşılaşılan problemler ve dersin daha etkili olmasına yönelik öneriler belirlenmeye çalışılmıştır. Çalışmada, ZOD amaçları tanımlanmış ve bu alanda kazanımların artırılmasına ve problemlerin giderilmesine yönelik öneriler sunulmuştur. Ülkemizin beyin gücünün artmasında çok önemli katkıları olacağına inanılan ZOD ile tanımlanacak davranışların öğrencilere kazandırılmasının, öğrencilerin bilişsel, duyuşsal ve devinişsel yeterliklerinin gelişiminde ve gelişmiş insan gücünün oluşturulmasında çok önemli olduğuna, bu nedenle de ZOD dersine gereken önemin verilmesi gerektiğine inanılmaktadır.

Anahtar sözcükler: zekâ oyunları dersi, katılımcı görüşü.

ABSTRACT: This research has been conducted to investigate the ways how teachers and students perceive Mind Games Courses, which had been recently put into curriculum. Data was collected from Bayburt middle schools in 2013-2014 school year. In order to investigate teachers and students' perspective, five open-ended questions were given to 133 students and 15 teachers. In this descriptive research, it has been aimed to define the problems confronted, the goals of the course perceived, and the suggestions to improve the course content. It has been re-defined the goals of the Mind Games Course, improved the course content, and provided suggestions to overcome the problems. It is our belief that the course has significant importance in improving the work force, the number of well-educated people, and therefore the level of development of our country.

Key words: mind games course, participant perspective

ORTAOKUL ÖĞRENCİLERİNİN PROBLEM ÇÖZME TUTUMLARININ ÇEŞİTLİ DEĞİŞKENLER AÇISINDAN İNCELENMESİ ÜZERİNE BİR ARAŞTIRMA

A RESEARCH ON THE EXAMINING OF SECONDARY STUDENTS' PROBLEM SOLVING ATTITUDES IN TERMS OF DIFFERENT VARIABLES

Dilek SEZGİN MEMNUN
Uludağ Üniversitesi
dsmemnun@uludag.edu.tr

ÖZET: Bu araştırma, ortaokul beşinci ve altıncı sınıf öğrencilerinin problem çözme tutumlarının incelenmesi ve bu tutumların cinsiyet, sınıf düzeyi ve matematik dersi başarıları değişkenlerine göre değişiminin araştırılması amacıyla gerçekleştirilmiştir. Bu amaçla, 2012-2013 eğitim-öğretim bahar döneminde Bursa ilinde bulunan 4 farklı ortaokulda öğrenim görmekte olan beşinci ve altıncı sınıf öğrencileri arasından rasgele seçilen toplam 238 öğrenciye *Matematik Problemi Çözme Tutum Ölçeği* uygulanmıştır. Öğrencilerin ölçeği tamamlamaları yaklaşık 15 dakika sürmüştür. Ulaşılan araştırma verilerinin analizinde, betimsel istatistiklerin yanında bağımsız örneklem t-testi, korelasyon analizi, Mann-Whitney U ve Ki-Kare testleri kullanılmıştır. Ulaşılan veriler, SPSS 14.0 paket programı aracılığı ile analiz edilmiştir. Araştırmanın sonucunda, ortaokul beşinci ve altıncı sınıf öğrencilerinin büyük çoğunluğunun matematik problemi çözme hakkında pozitif tutuma sahip oldukları anlaşılmıştır. Beşinci ve altıncı sınıf öğrencilerinin matematik problemi çözme tutumu kapsamındaki *hoşlanma* boyutu puanları arasında hem cinsiyet hem de sınıf düzeyleri bakımından anlamlı farklılıklara ulaşılmıştır. Ayrıca, bu öğrencilerin matematik problem çözme tutumu *hoşlanma* boyutu puanları ile matematik dersi başarı notları arasında orta düzeyde, *öğretim* boyutu puanları ile matematik dersi başarı notları arasında düşük düzeyde pozitif ve anlamlı ilişkiler olduğu açıklanmıştır.

Anahtar sözcükler: Matematik problemi, tutum, problem çözme tutumu, beşinci ve altıncı sınıf öğrencisi.

ABSTRACT: The aim of this research is to examine the problem solving attitudes of secondary fifth- and sixth-grade students and investigate the variation of their problem solving attitudes according to gender, grades or mathematics course success. *Problem Solving Attitudes Scale* was administered to a total of 238 fifth- and sixth-grade students who were studying in four different middle schools in Bursa during the 2012-2013 academic year spring semester with this aim. These schools and students were selected randomly. These fifth- and sixth-grade students volunteered to participate in this study and completed this scale within 15 minutes. In addition to descriptive analysis, independent samples t-test, correlation analysis, Mann-Whitney U and Chi-Square tests were used for analyzing the data. Data were analyzed using the SPSS 14.0 program. Research findings indicate that many of these fifth- and sixth-grade students have positive problem solving attitudes. It has been understood that there are significant differences in fifth- and sixth-grade students' *like* dimension scores within the context of problem solving attitudes in terms of both gender and grade level. Additionally, it has been revealed that there is an intermediate positive relationship between *like* dimension scores and mathematics course success, and there is a low positive relationship between *teaching* dimension scores and course success of these students.

Key words: Mathematical problem, attitudes, problem solving attitudes, fifth and sixth grade students.

GİRİŞ

Eğitimde bilişsel değişken ve stratejilerin yanında duyuşsal değişkenler de oldukça önemlidir ve bu duyuşsal değişkenlerden biri de tutum değişkenidir. Bireylerin matematik ile ilgili duygularından ortaya çıkan matematiğe yönelik tutumları da, matematik öğrenme ve öğretilmede önem taşımaktadır (Royster, Haris ve Schoeps, 1999). Bununla birlikte, matematik dersi ilköğretimden üniversite eğitimine bireylerin olumsuz tutum geliştirdiği derslerden biridir (Avcı, Coşkuntuncel ve İnandı, 2011). Bireyler matematiği tam olarak anlayamamakta ve bu nedenle de matematik dersine karşı olumsuz tutum sergilemektedirler (Yıldızlar, 2001). Oysaki matematik hakkında olumlu tutuma sahip olan bireyler olumsuz tutuma sahip olan bireylerden daha fazla başarılıdırlar (Reyes, 1984; Ma, 1997). Bu nedenle, öğrencilerin olumlu tutum oluşturmaları, var olan

tutumlarını geliřtirmeleri, olumlu tutumlarını korumaları ve güçlendirmeleri sürekli olarak önemsenmelidir (Suydam ve Weaver, 1975).

Matematik eğitiminin temel amaçlarından biri, bireylere problem çözme becerisinin kazandırılmasıdır. Çünkü matematiksel bilgileri anlama ve bu bilgiler arasında ilişki kurma problem çözme sürecinde meydana gelmektedir. Matematikte problem çözme, “problemi çözme gayreti sırasındaki süreçlerin tümü”dür (Altun, 2008). National Council of Teachers of Mathematics (2001) tarafından *Okul Matematiğinin Prensipleri ve Standartları*’nda *Okul Matematiği için Standartlar* başlığı altında yer alan üçüncü bölümde de, matematikte problem çözme “çözüm yolunun bilinmediği bir durumla meşgul olmak” olarak tanımlanmıştır. Bu nedenle, matematikte problem çözme bilinmeyen bir durumla meşgul olma isteği ve gayreti gerektirmektedir. Bireylerin problem çözme esnasında bu istek ve gayreti gösterebilmeleri de, matematikte problem çözme konusunda olumlu inanç ve tutuma sahip olmaları ile mümkün olabilir. Bireylerin tutumlarının başarı da oldukça önemli olduğu da bilinmektedir (Aşkar, 1986; Maye ve Kishor, 1997).

Ülkemizde ilköğretim düzeyinde matematiğe yönelik tutumların incelendiği farklı arařtırmalar (Köğçe, Yıldız, Aydın ve Altındağ, 2009; Şengül ve Öz, 2008; Taşdemir, 2008) bulunmakla birlikte, problem çözme tutumlarının detaylı bir biçimde incelendiği arařtırmaya rastlanamamıştır. Bu nedenle, bu arařtırmada ortaokul beşinci ve altıncı sınıf öğrencilerinin problem çözme tutumları ve bu tutumlarının cinsiyet, sınıf düzeyleri ve matematik dersi başarılarına göre deęişimi incelenmiştir. Bu amaçla, aşağıda yer alan arařtırma problemlerine cevap aranmıştır:

1. Ortaokul öğrencilerinin matematik problemi çözme tutumları nasıldır?
2. Ortaokul beşinci ve altıncı sınıf öğrencilerinin matematik problemi çözme tutum puanları (hoşlanma ve öğretim boyut puanları) cinsiyete göre farklılaşmakta mıdır?
3. Ortaokul beşinci ve altıncı sınıf öğrencilerinin matematik problemi çözme tutum puanları (hoşlanma ve öğretim boyut puanları) sınıf düzeylerine göre farklılaşmakta mıdır?
4. Ortaokul öğrencilerinin matematik problemi çözme tutum puanları ile matematik dersi başarıları arasında anlamlı bir ilişki var mıdır?

YÖNTEM

Arařtırma Yöntemi

Bu arařtırma, tarama modelinde gerçekleştirilmiş olan bir arařtırmadır. Bilindiği gibi tarama modelleri, geçmişte ya da var olan bir durumu var olduğu şekliyle betimlemeyi amaçlayan arařtırma yaklaşımlarıdır. Evren hakkında genel bir yargıya ulaşmak amacıyla evrenin tümü veya evrenden alınacak bir grup örnek veya örneklem üzerinde yapılan düzenlemelerdir (Karasar, 2003).

Katılımcılar

Arařtırmanın evrenini 2012-2013 eğitim-öğretim bahar döneminde Bursa ilinde yer alan ilköğretim okullarında öğrenim görmekte olan beşinci ve altıncı sınıf öğrencileri oluşturmaktadır. Arařtırmanın örneklemini ise, 2012-2013 eğitim-öğretim döneminde Bursa ilinde bulunan ortaokullar arasından tesadüfi örnekleme yöntemi ile belirlenen 4 farklı ortaokulda öğrenim görmekte olan beşinci ve altıncı sınıf öğrencileri arasından rasgele seçilen toplam 238 beşinci ve altıncı sınıf öğrencisi oluşturmaktadır. Arařtırmaya katılan öğrencilerin 116 (%48.7)’si beşinci sınıf, 122 (%51.3)’si altıncı sınıf öğrencisidir. Arařtırmaya katılan bu öğrencilerin 104’ü kız ve 134’ü ise erkek öğrencidir.

Veri Toplama Aracı

Bu arařtırmanın verileri, Çanakçı ve Özdemir (2011) tarafından geliştirilen *Matematik Problemi Çözme Tutum Ölçeği*’nin ortaokul beşinci ve altıncı sınıf öğrencilerine uygulanması ile elde edilmiştir.

Matematik Problemi Çözme Tutum Ölçeği, beşli likert türünde hazırlanmış olan, toplam 19 maddeden oluşan iki boyutlu bir ölçektir. Ölçekten alınabilecek en yüksek puan 95, en düşük puan ise 19’dur. Toplam 10 maddeden oluşan birinci boyutta (hoşlanma boyutu) yer alan maddeler genel olarak öğrencinin problem çözme sevip sevmediği, problem çözerken sıkılıp sıkılmadığı ya da zorlanıp zorlanmadığı ile ilgili tutumlarını yansıtmaktadır. Diğer boyutta (öğretim boyutu) yer alan maddeler ise, öğrencinin problem çözmenin öğretim süreci ile ilgili tutumlarını yansıtmaktadır. Her iki faktör için açıklanan toplam varyans miktarı %42.693 olarak belirlenmiştir. Test-tekrar test tekniği kullanılarak hesaplanan Pearson korelasyon katsayısı 0.89 olarak bulunmuştur. Cronbach alfa iç tutarlılık katsayıları ölçeğin tümü, hoşlanma boyutu ve öğretim boyutu için

sırasıyla 0.848, 0.869 ve 0.777 olarak hesaplanmıştır. Aynı zamanda, bu araştırmada *Matematik Problemi Çözme Tutum Ölçeği*'nin ortaokul beşinci ve altıncı sınıf öğrencilerine uygulanması sonucunda elde edilen elde edilen veriler için Cronbach alfa katsayısı 0.87 olarak hesaplanmıştır. Bir test için hesaplanan güvenilirlik katsayısının .70 ve daha yüksek olması test puanlarının güvenilirliği için genel olarak yeterli görülmektedir (Büyüköztürk, 2010). Bu durum, araştırma kapsamına alınan ölçme aracı için ölçme puanlarının yeterli olduğunu göstermektedir.

Verilerin Toplanması ve Analizi

Araştırmaya katılan öğrencilere *Matematik Problemi Çözme Tutum Ölçeği* matematik dersi öğretmenleri eşliğinde uygulanmıştır. Öğrencilerin ölçeği tamamlamaları yaklaşık 15 dakika sürmüştür. Ayrıca, matematik dersi öğretmenleri aracılığı ile araştırmaya katılan ortaokul beşinci ve altıncı sınıf öğrencilerinin matematik dersi notlarına da ulaşılmıştır.

Araştırmaya katılan öğrencilerin ölçeklerde yer alan maddelere verdikleri cevaplardan elde edilen veriler, belirlenen farklı 5 dereceye göre analiz edilmiştir. Bu aşamada, öğrencilerin ölçekte yer alan maddelerden aldıkları toplam puanların madde sayılarına bölünmesi sonucunda ortalama puanlara ulaşılmıştır. Ardından, grup aralık katsayısı değerlerinin “ölçme sonuçları dizisindeki en büyük değer ile en küçük değer arasındaki farkın belirlenen grup sayısına bölünerek (Kan, 2009)” hesaplanmasıyla puan aralık genişlikleri belirlenmiştir. Bu araştırmada, öğrencilerin ölçeklere vermiş oldukları cevapların için değerlendirme aralığı da $(5-1)/5=0.80$ olarak belirlenmiştir. Buna göre, öğrencilerin *Matematik Problemi Çözme Tutum Ölçeği*'ne vermiş oldukları cevapların yorumlanması için aralıklar; 4.21-5.00 kesinlikle katılıyorum, 3.41-4.20 katılıyorum, 2.61-3.40 kararsızım, 1.81-2.60 katılmıyorum ve 1.00-1.80 kesinlikle katılmıyorum olarak belirlenmiştir.

Ulaşılan veriler, SPSS 14.0 paket programı aracılığı ile analiz edilmiştir. Veri dağılımının normallik varsayımının test edilmesinde Kolmogorov-Smirnov Z testinden, verilerin homojenliğini test etmede ise Levene istatistiğinden faydalanılmıştır. Yapılan inceleme sonucunda, hoşlanma alt boyutu ile ölçeğin tümüne ait veri dağılımının homojen bir dağılım gösterdiği ($F_H=0.047$, $p=.828$ ve $F_T=2.603$, $p=.108$); ancak öğretim alt boyutu için veri dağılımının heterojen bir dağılım gösterdiği ($F_0=5.147$, $p=.024$) belirlenmiştir. Bu nedenle, verilerin analizinde betimsel istatistiklerin yanında *hoşlanma* alt boyutu ile ölçeğin *tümü* için bağımsız örneklem t-testi ile korelasyon analizi kullanılmıştır. Korelasyon analizinin değerlendirilmesinde Pearson korelasyon katsayısı için 0.00-0.30 aralığı düşük, 0.31-0.70 aralığı orta ve 0.71-1.00 aralığı ise yüksek düzeyde anlamlı bir ilişki biçiminde yorumlanmıştır (Büyüköztürk, 2010). Bununla birlikte, *öğretim* alt boyutu için de Mann-Whitney U testi ile Ki-Kare testi kullanılmıştır.

BULGULAR ve YORUM

Bu bölümde, ortaokul beşinci ve altıncı sınıf öğrencilerinin matematik problemi çözme tutum puanlarının cinsiyet ile sınıf düzeylerine göre değişiminin incelenmesi amacıyla gerçekleştirilen betimsel istatistik sonuçlarına yer verilmiştir. Bununla birlikte, beşinci ve altıncı sınıf öğrencilerinin matematik problemi çözme tutum puanlarının cinsiyet ya da sınıf düzeylerine göre farklılaşmasına ilişkin t-testi sonuçları açıklanmıştır. Ayrıca, beşinci ve altıncı sınıf öğrencilerinin matematik dersi notları ile problem çözme tutum puanları arasındaki ilişkiyi araştıran korelasyon analizi sonuçları da raporlanmıştır.

“Ortaokul beşinci ve altıncı sınıf öğrencilerinin matematik problemi çözme tutumları nasıldır?” biçimindeki birinci araştırma problemine cevap aranırken, ortaokul öğrencilerinin ölçeğe verdikleri cevaplar cinsiyet ve sınıf düzeyleri açısından incelenmiş ve elde edilen bulgular Tablo 1 ve Tablo 2’de sunulmuştur.

Tablo 1. Öğrencilerin Problem Çözme Tutum Puanlarının Cinsiyete Göre Değişimi

Puan aralıkları	Cinsiyet					
	Kız		Erkek		Toplam	
	f	%	f	%	f	%
1.81-2.60 puan	5	2.1	4	1.7	9	3.8
2.61-3.40 puan	18	7.6	22	9.2	40	16.8
3.41-4.20 puan	44	18.5	44	18.5	88	37.0
4.21-5.00 puan	37	15.5	64	26.9	101	42.4
Toplam	104	46.7	134	56.3	238	100.0

Ortaokul beşinci ve altıncı sınıf öğrencilerinin matematik problemi çözme tutum puanlarının cinsiyete göre

değişimine ilişkin yüzde ve frekans değerleri incelendiğinde, öğrencilerin 189 (%79.4)'unun problem çözme hakkında pozitif tutuma sahip oldukları görülmüştür. Bununla birlikte, pozitif tutuma sahip olan erkek öğrencilerin sayısının ve yüzde değerlerinin (108- %45.4) kız öğrencilerin sayısı ve yüzde değerlerine (81-%34) kıyasla çok oluşu da dikkat çekicidir.

Tablo 2. Öğrencilerin Matematik Problemi Çözme Tutum Puanlarının Sınıf Düzeylerine Göre Değişimi

Puan aralıkları	Sınıf Düzeyleri					
	Beşinci sınıf		Altıncı Sınıf		Toplam	
	f	%	f	%	f	%
1.81-2.60 puan	5	2.1	4	1.7	9	3.8
2.61-3.40 puan	20	8.4	20	8.4	40	16.8
3.41-4.20 puan	37	15.5	51	21.5	88	37.0
4.21-5.00 puan	54	22.7	47	19.7	101	42.4
Toplam	116	48.7	122	51.3	238	100.0

Araştırmaya katılan ortaokul öğrencilerinin matematik problemi çözme tutum puanlarının sınıf düzeylerine göre değişimine ilişkin yüzde ve frekans değerleri incelendiğinde ise, pozitif tutuma sahip beşinci sınıf öğrencilerinin sayısı ve yüzde değerleri (116-%38.2) ile pozitif tutuma sahip olan altıncı sınıf öğrencilerinin sayısı ve yüzde değerlerinin (122-%41.2) de birbirine oldukça yakın olduğu anlaşılmıştır.

Araştırma kapsamında yer alan “Ortaokul beşinci ve altıncı sınıf öğrencilerinin matematik problemi çözme tutum puanları (hoşlanma ve öğretim boyut puanları) cinsiyete göre farklılaşmakta mıdır?” biçimindeki ikinci araştırma problemine cevap aranırken, öğrencilerin problem çözme tutumları ile cinsiyet arasında anlamlı farklılıklar olup olmadığı bağımsız örneklem t-testi ve Mann-Whitney U testi ile ortaya koyulmaya çalışılmıştır. Ortaokul öğrencilerinin matematik problemi çözme *tutum* puanları ile *hoşlanma* alt boyut puanlarının cinsiyete göre farklılaşıp farklılaşmadığını ortaya koymak amacıyla gerçekleştirilen bağımsız örneklem t-testi sonuçlarına, Tablo 3’te yer verilmiştir.

Tablo 3. Problem Çözme Tutum Puanlarının Cinsiyete Göre Değişimine İlişkin t-Testi Sonuçları

	Cinsiyet	N	\bar{x}	ss	t	p
Problem Çözme Tutumu	Kız	104	3.90	0.657	-1.318	0.191
	Erkek	134	4.01	0.684		
Hoşlanma Boyut Puanları	Kız	104	3.50	0.962	-2.027	0.042
	Erkek	134	3.75	0.902		

Araştırmaya katılan kız ve erkek öğrencilerin hem matematik problemi çözme tutumu ortalama puanları arasında anlamlı farklılıklara ulaşamamıştır ($t_p(236) = -1.318$; $p > .05$). Bununla birlikte, kız ve erkek öğrencilerin problem çözme tutumlarını oluşturan *hoşlanma* boyut puan ortalamaları arasında anlamlı farklılığa ulaşılmıştır ($t_h(236) = -2.027$; $p < .05$). Yapılan incelemelerde, erkek öğrencilerin matematik problemi çözme tutumu ortalama puanları ($\bar{x} = 4.01$) ile kız öğrencilerin problem çözme tutumu ortalama puanlarının ($\bar{x} = 3.90$) birbirine oldukça yakın düzeyde olduğu görülmüştür.

Bu ortaokul öğrencilerinin problem çözme tutumu *öğretim* alt boyut puanlarının cinsiyete göre farklılaşıp farklılaşmadığını ortaya koymak amacıyla gerçekleştirilen Mann-Whitney U testi sonuçlarına ise, Tablo 4’te yer verilmiştir.

Tablo 4. Tutum Puanlarının Cinsiyete Göre Farklılaşmasına İlişkin Mann-Whitney U Testi Sonuçları

Cinsiyet	n	Sıralar Ortalaması	Sıralar Toplamı	U	Z	p
Kız	104	113.67	11822.00	6362.00	-1.153	.249
Erkek	134	124.02	16619.00			

Uygulanan bu parametrik olmayan analiz sonucuna göre, araştırmaya katılan kız ve erkek öğrencilerin problem çözme tutumlarını oluşturan *öğretim* boyut ortalama puanları arasında anlamlı farklılıklara ulaşılamamıştır ($U=6362.00$; $p>.05$). Sıra ortalamaları dikkate alındığında, erkek öğrencilerin problem çözme tutumlarının kız öğrencilerin tutumlarına göre daha yüksek olduğu anlaşılmaktadır.

Araştırma kapsamında yer alan “Ortaokul beşinci ve altıncı sınıf öğrencilerinin matematik problemi çözme tutum puanları (hoşlanma ve öğretim boyut puanları) sınıf düzeylerine göre farklılaşmakta mıdır?” biçimindeki üçüncü araştırma problemine cevap aranırken, öğrencilerin problem çözme tutumları ile sınıf düzeyleri arasında anlamlı farklılıklar olup olmadığı bağımsız örneklem t-testi ve Mann-Whitney U testi ile ortaya koyulmaya çalışılmıştır. Ortaokul öğrencilerinin matematik problemi çözme *tutum* puanları ile *hoşlanma* alt boyut puanlarının cinsiyete göre farklılaşıp farklılaşmadığını ortaya koymak amacıyla gerçekleştirilen bağımsız örneklem t-testi sonuçlarına, Tablo 5’te yer verilmiştir.

Tablo 5. Tutum Puanlarının Sınıf Düzeylerine Göre Farklılaşmasına İlişkin t-Testi Sonuçları

		Sınıf Düzeyi	N	\bar{x}	ss	t	p
Problem Çözme Tutumu	Beşinci Sınıf		116	4.00	0.716	0.742	0.459
	Altıncı Sınıf		122	3.93	0.632		
Hoşlanma Boyut Puanları	Beşinci Sınıf		116	3.79	0.932	2.441	0.015
	Altıncı Sınıf		122	3.50	0.919		

Araştırmaya katılan kız ve erkek öğrencilerin hem problem çözme tutumu ortalama puanları arasında anlamlı farklılıklara ulaşılamamıştır ($t_p(236)=-0.742$; $p>.05$). Yapılan incelemelerde, beşinci sınıf öğrencilerinin matematik problemi çözme tutumu puan ortalamaları ($\bar{x}=4.00$) ile altıncı sınıf öğrencilerinin problem çözme tutumu puan ortalamalarının ($\bar{x}=3.93$) birbirine oldukça yakın düzeyde olduğu anlaşılmıştır. Bununla birlikte, beşinci ve altıncı sınıf öğrencilerinin matematik problemi çözme tutumu kapsamındaki *hoşlanma* boyutu ortalama puanları arasında anlamlı farklılığa ulaşılmıştır ($t_h(236)=2.441$; $p<.05$).

Ortaokul öğrencilerinin matematik problemi çözme tutum *öğretim* alt boyut puanlarının cinsiyete göre farklılaşıp farklılaşmadığını ortaya koymak amacıyla gerçekleştirilen Mann-Whitney U testi sonuçlarına ise, Tablo 6’da yer verilmiştir.

Tablo 6. Tutum Puanlarının Sınıf Düzeylerine Göre Değişimine İlişkin Mann-Whitney U Testi Sonuçları

Sınıflar	n	Sıralar Ortalaması	Sıralar Toplamı	U	Z	p
Beşinci Sınıf	116	120.67	13998.00	6940.00	-0.257	.797
Altıncı Sınıf	122	118.39	14443.00			

Uygulanan bu parametrik olmayan analiz sonucuna göre Araştırmaya katılan beşinci ve altıncı sınıf öğrencilerinin matematik problemi çözme tutumları kapsamındaki *öğretim* boyut ortalama puanları arasında anlamlı farklılıklara ulaşılamamıştır ($U=6940.00$; $p>.05$). Sıra ortalamaları dikkate alındığında, beşinci sınıf öğrencilerinin problem çözme tutumlarının altıncı sınıf öğrencilerinin tutumlarına göre daha yüksek olduğu anlaşılmaktadır.

Araştırma kapsamında yer alan “Ortaokul öğrencilerinin matematik problemi çözme tutum puanları ile matematik dersi başarıları arasında anlamlı bir ilişki var mıdır?” biçimindeki dördüncü araştırma problemine cevap aranırken de, öğrencilerin matematik problemi çözme tutum puanları ve hoşlanma boyutu puanları ile matematik dersi başarı puanları arasında anlamlı ilişki olup olmadığı korelasyon analizi ile ortaya koyulmaya çalışılmıştır (Tablo 7).

Tablo 7. Tutum İle Ders Başarı Puanları Arasındaki İlişkiyi Araştıran Korelasyon Analizi Sonuçları

	N	Pearson Korelasyonu	p
Problem Çözme Tutum Puanları Matematik Dersi Başarı Notları	238	0.380*	.00

* $p < .05$

Araştırmaya katılan beşinci ve altıncı sınıf öğrencilerinin matematik problem çözme tutumu puanları ile matematik dersi başarı notları arasında orta düzeyde, pozitif ve anlamlı bir ilişki bulunmaktadır ($r_p=0.380$, $r_n=0.340$, $p<.05$).

SONUÇLAR

Bu araştırmada elde edilen bulgular, araştırmaya katılan beşinci ve altıncı sınıf öğrencilerinin büyük çoğunluğunun matematik problemi çözme hakkında pozitif tutuma sahip olduklarını göstermektedir.

Araştırmaya katılan beşinci ve altıncı sınıf öğrencilerinin hem matematik problemi çözme tutumu puan ortalamaları hem de problem çözme tutumu kapsamındaki *öğretim* boyutu puan ortalamaları arasında anlamlı farklılıklar bulunamamıştır. Benzer şekilde, kız ve erkek öğrencilerin hem matematik problemi çözme tutumu puan ortalamaları hem de problem çözme tutumu kapsamındaki *öğretim* boyutu puan ortalamaları arasında anlamlı farklılıklar bulunamamıştır. Aksine, öğrencilerin matematik problemi çözme tutumu kapsamındaki *hoşlanma* boyutu ortalama puanları arasında hem cinsiyet hem de sınıf düzeyleri bakımından anlamlı farklılıklara ulaşılmıştır. Bu durum, sınıf düzeyi arttıkça öğrencilerin problem çözmeyi daha fazla sevdiğini düşündürmektedir. Erkek öğrencilerin hoşlanma alt boyut ortalama puanlarının yüksek olması da, erkek öğrencilerin matematik problemi sevmeyi daha çok sevdiğine işaret etmektedir.

Öğrencilerin matematik problem çözme tutumu *hoşlanma* boyutu ortalama puanları ile matematik dersi başarı notları arasında orta düzeyde, *öğretim* boyutu ortalama puanları ile matematik dersi başarı notları arasında düşük düzeyde pozitif ve anlamlı bir ilişki bulunmaktadır. Bu durum, öğrencilerin problem çözmeyi sevmeleri (*hoşlanma* boyutu) ya da problem çözmenin öğretim süreci ile ilgili tutumları (*öğretim* boyutu) arttıkça matematik dersi başarı notlarının da arttığını gösterir niteliktedir. Yapılacak olan araştırmalarda, farklı yaş gruplarında matematik problemi çözmeye ilişkin inanç ve tutumlar incelenebilir ve karşılaştırmalar yapılabilir.

KAYNAKLAR

- Altun, M. (2008). *İlköğretim ikinci kademe (6, 7 ve 8. sınıflarda) matematik öğretimi*. Bursa: Aktüel Yayınları.
- Aşkar, P. (1986). Matematik dersine yönelik tutumu ölçen likert tipi bir ölçeğin geliştirilmesi. *Eğitim ve Bilim*, 11(62), 31-36.
- Avcı, E., Coşkuntuncel, O. ve İnandı, Y. (2011). Ortaöğretim on ikinci sınıf öğrencilerinin matematik dersine karşı tutumları. *Mersin Üniversitesi Eğitim Fakültesi Dergisi*, 7(1), 50-58.
- Büyüköztürk, Ş. (2010). *Sosyal bilimler için veri analizi el kitabı*. Ankara: Pegem Yayıncılık, s. 170.
- Çanakçı, O. ve Özdemir, A.Ş. (2011). Matematik problemi çözme tutum ölçeğinin geliştirilmesi. *Abant İzzet Baysal Üniversitesi Eğitim Fakültesi Dergisi*, 11(1), 119-136.
- Kan, A. (2009). Ölçme sonuçları üzerinde istatistiksel işlemler. H. Atılgan (Ed.), *Eğitimde ölçme ve değerlendirme* (s. 397-456). Ankara: Anı Yayıncılık, s. 407.
- Karasar, N. (2003). *Bilimsel araştırma yöntemi* (12. Baskı). Ankara: Nobel Yayın Dağıtım.
- Köğce, D., Yıldız, C., Aydın, M. ve Altındağ, R. (2009). Examining elementary school students' attitudes towards mathematics in terms of some variables. *Procedia-Social and Behavioral Sciences*, 1(1), 291-295.
- Ma, X. (1997). Reciprocal relationships between attitude toward mathematics and achievement in mathematics. *The Journal of Educational Research*, 90(4), 221-229.
- Maye, X., & Kishor, N. (1997). Assessing the relationship between attitude toward mathematics and achievement in mathematics: A meta-analysis. *Journal for Research in Mathematics Education*, 28(1), 26-47.
- National Council of Teachers of Mathematics (2001). *Principles and Standards for School Mathematics*. Reston, VA: NCTM Publications.
- Reyes, L. H. (1984). Affective variables and mathematics education. *The Elementary School Journal*, 84(3), 558-581.
- Royster, D.C., Haris, M.K. & Schoeps, N. (1999). Dispositions of college mathematics students. *International Journal of Mathematical Education in Science and Technology*, 30(3), 317-333.
- Suydam, M. N. & Weaver, J. F. (1975). Research on mathematics learning. In J. N. Payne (Ed.), *Mathematics Learning in Early Childhood: Thirty-Seventh Yearbook* (pp. 44-67). Reston, VA: National Council of Teachers of Mathematics.
- Şengül, S. ve Öz, C. (2008). İlköğretim 6. sınıf ünitesinde çoklu zeka kuramına uygun öğretimin öğrenci tutumuna etkisi. *İlköğretim Online*, 7(3), 800-813.
- Taşdemir, C. (2008). İlköğretim 6, 7 ve 8. sınıf öğrencilerinin matematik dersine yönelik tutumlarının bazı değişkenlere göre belirlenmesi. *Atatürk Üniversitesi Kazım Karabekir Eğitim Fakültesi Dergisi*, 17, 185-201.

Yıldızlar, M. (2001). *Matematik problemlerini çözebilme yöntemleri*. Ankara: Eylül Yayınevi.

AN EXAMINING OF MIDDLE SCHOOL STUDENTS' METACOGNITIVE SKILLS AND MATHEMATICS PROBLEM SOLVING ATTITUDE

Fadime GÜR

Graduate Student, Institute Of Education Sciences, Dokuz Eylul University, Izmir, Turkey

Berna CANTÜRK GÜNHAN

Assistant Professor, Department of Elementary Mathematics Education, Dokuz Eylul University, Izmir, Turkey

ABSTRACT: In today's educational approach instead of memorizing individuals who are aware of their own learning and correctly perceives itself is aimed to train individuals. For this reason, it is expected from individuals to be aware of the cognitive processes, to think about thinking and how to stand on rather than what they had learned. In studies, it is showed that students were using awareness of their own thinking in problem solving situations and planned learning processes. For this reason, it is found to be very important for the relationship between mathematics and metacognition to investigate in order to explain the process of problem solving and cognitive activities that people use in this process. The purpose of this study is to examine mathematics problem solving attitudes of middle school students and their metacognitive skills and compare a variety of variables in terms. For this purpose, in the 2013-2014 academic year at a middle school in the province of Denizli with 5th,6th,7th and 8th grades studying a descriptive study was conducted with a total of 204 students. The data were collected using Aydın and Ubuz (2010) by adapted to Turkish on the "Metacognitive Awareness Inventory" and Çanakçı (2008) by developed "Mathematics Problem Solving Attitude Scale". The data obtained in the research process through the program SPSS 15.0 statistical package was analyzed. In the analysis of the survey data independent samples t-test, One-Way Analysis of Variance (ANOVA), Pearson Product Moment Correlation Coefficient was used. At the end of the study, it was found that metacognitive skills of the middle school students differed across grade levels, and math problem-solving attitudes of the students differed across grade levels and gender. Metacognitive skills of students with mathematics problem solving attitude, there is a significant relationship between success in mathematic course was observed. In addition, there was a significant correlation between metacognitive skills and mathematics problem solving attitudes. These results are based on students' mathematics problem solving skills and to develop their problem-solving attitude and will be included in the assessment process, taking responsibility for their own learning and metacognitive skills can develop self regulation , learning environment should be prepared.

Key Words: Metacognitive skills, mathematics problem solving attitudes, middle school students.

ORTAOKUL ÖĞRENCİLERİNİN BİLİMSEL YARATICILIKLARININ FEN LABORATUVARI DENEYİMLERİ İLE GELİŞTİRİLMESİ

IMPROVING MIDDLE SCHOOL STUDENTS' CREATIVITY WITH SCIENCE LABORATORY EXPERIENCES

Sema AYDIN CERAN
Milli Eğitim Bakanlığı
sema.aydin.ceran@gmail.com.tr

Seda ÇAVUŞ GÜNGÖREN
Giresun Üniversitesi
sdacavus@gmail.com.tr

Nilda BOYACIOĞLU
Milli Eğitim Bakanlığı
nildaboyacioglu@hotmail.com.tr

ÖZET: Bu araştırmanın amacı 6. ve 8. sınıf öğrencilerinin bilimsel yaratıcılıklarının fen laboratuvarı deneyimleriyle gelişimini incelemektir. Deneysel yöntemin kullanıldığı bu araştırma 2013-2014 Eğitim-Öğretim yılı güz döneminde 18 hafta süreyle devam etmiştir. Çalışmaya 6. ve 8. sınıf olmak üzere 80 ortaokul öğrencisi katılmıştır. Deney gruplarında tüm dersler laboratuvarda gerçekleştirilmiş, açık uçlu deney ve etkinlikler uygulanmıştır. Böylece öğrencilerin araştırma ve sorgulama becerileri pekiştirilmiştir. Kontrol gruplarıyla ise yine laboratuvar ortamında daha çok kapalı uçlu deneylerin uygulandığı dersler gerçekleştirilmiştir. Veriler, Hu ve Adey (2002) tarafından geliştirilen, Deniz Çeliker ve Balım (2012) tarafından Türkçeye uyarlanan 'Bilimsel Yaratıcılık Ölçeği' ile toplanmıştır. Analizler sonucunda öğrencilerin laboratuvar deneyimlerinin bilimsel yaratıcılık düzeylerini artırdığı tespit edilmiştir. Bu artış 6. sınıflarda 8. sınıflara göre daha fazla olmakla birlikte 8. sınıf öğrencilerinin bilimsel yaratıcılık düzeyinin uygulama öncesi ve sonrasında da 6. sınıflardan daha düşük seviyede olduğu dikkat çekmektedir.

Anahtar sözcükler: Bilimsel Yaratıcılık, Laboratuvar Deneyimleri, Fen Eğitimi.

ABSTRACT: The aim of this study is to investigate the development of sixth and eighth grade students' scientific creativity through science laboratory experiences. The experimental method was used during 18 weeks in the fall semester of 2013-2014 academic year. 80 students participated to the study as half of them attended as control group and half of them experimental group. The experimental group conducted their all lessons in laboratory by using open ended experiments and activities accordance with the scope of the content. In this way, students' inquiry skills were reinforced. On the other hand, closed-ended experiments were utilized to the control group. Data were gathered through "Scientific Creativity Scale" which was developed by Hu and Adey (2002) and was translated into Turkish by Deniz Çeliker and Balım (2012). The results revealed that laboratory experiments increases students' scientific creativity. In other words, sixth grade students' performing laboratory lessons with open-ended experiments exhibited more scientific creativity than eighth grade students. Moreover, it was found that laboratory implications increased scientific creativity of sixth grade students more than eight graders.

Keywords: Scientific Creativity, Laboratory Experiences, Science Education.

GİRİŞ

Fen okuryazarı bireyler, kendilerini toplumsal problemlerin çözümü konusunda sorumlu hisseden, yaratıcı ve analitik düşünme becerileri yardımıyla bireysel ya da işbirliğine dayalı alternatif çözüm önerileri üretebilirler (MEB, 20013). Ancak bu bireylerin bu özelliklerle donatılması ya da bu özelliklerinin daha çok ortaya çıkarılması için eğitim sürecinde uygun ortamlar sağlanmalıdır. Lee ve Erdogan (2007), öğretmenlerin öğretim stratejilerinin ve öğrenme ortamlarının öğrencilerin fene karşı tutumlarında ve yaratıcılıklarında etkili olduğunu belirtmişlerdir. Hu ve Adey (2002), bu konuda yapılacak çalışmaların özellikle toplumun bilime bakış açısını ortaya koymasından değerli olduklarını ifade etmişlerdir. Bazı araştırmalar laboratuvarda yapılan etkinliklerin öğrencilerin fen kavramlarını öğrenmelerini ve bilimsel düşünmeyi dersten daha etkili bir şekilde kazandırdığını göstermiştir (Noiwong ve Phinyocheep, 2012).

Bu araştırma fen eğitimi için önemli olan bilimsel anlamda yaratıcı düşünme ile fen laboratuvarı deneyimlerinin etkisini araştırmaktadır. Öncü (2003) bilimsel yaratıcılığın eğitimin üst kademelerinde azalma gösterdiğini ifade etmiştir. Aydın Ceran ve arkadaşları da (2014) yapmış oldukları çalışmada benzer bir sonuç elde etmiş özelliklerle 7. sınıf öğrencilerinin diğer sınıf kademelerinden (8. sınıflar) daha yüksek olduğunu belirlemiştir. Devam niteliğinde olan bu araştırmada ise öğrencilerin 2013 yılında yenilenen fen öğretim programı paralelinde araştırmaya ve sorgulamaya dayalı ortamlar ile pekiştirilen yaratıcılık özelliklerinin aralarında belirli bir yaş farkı bulunan 6. ve 8. sınıf öğrencilerinin bilimsel yaratıcılıklarının ne ölçüde etkilendiğinin incelenmesidir.

YÖNTEM

Çalışma Grubu

Bu araştırma tam donanımlı bir laboratuara sahip olan bir ortaokulda 6. ve 8. sınıf öğrencileriyle gerçekleştirilmiştir. Araştırmaya 40 tane 6.sınıf (n=20 deney grubu ve n=20 kontrol grubu) ve 40 tane 8. sınıf (n=20 deney grubu ve n=20 kontrol grubu) öğrencisi katılmıştır. 6. ve 8. sınıflardan birer deney ve kontrol grubu rastgele seçilmiştir. 6. sınıf deney grubu öğrencilerine açık uçlu araştırma sorgulamaya dayalı deney teknikleri ile hazırlanan çalışma yaprakları 'Canlılarda Üreme-Büyüme-Gelişme, Kuvvet ve Hareket, Madde ve Değişim, Yaşamımızdaki Elektrik' ünitelerinde uygulanmıştır. 8. sınıf deney grubu öğrencilerine de yine açık uçlu araştırma sorgulamaya dayalı deney teknikleriyle hazırlanmış çalışma yaprakları 'Hücre Bölünmesi ve Kalıtım, Kuvvet ve Hareket, Maddenin Yapısı ve Özellikleri' ünitelerinde uygulanmıştır. 6.ve 8. sınıf kontrol gruplarıyla dersler laboratuvarında kapalı uçlu deneyler ile yürütülmüştür. Araştırma 18 hafta (1 dönem) sürmüştür.

Veri Toplama Araçları

Çalışmada öğrencilerin bilimsel yaratıcılık düzeylerini belirlemek amacıyla Hu ve Adey (2002) tarafından geliştirilen, Deniz Çeliker ve Balım (2012) tarafından Türkçe'ye uyarlanan 'Bilimsel Yaratıcılık Ölçeği (BYÖ)' kullanılmıştır. BYÖ açık uçlu 7 sorudan oluşmaktadır ve ölçekteki her bir madde birden çok alt boyutu kapsamaktadır. Ölçekte birinci madde bilimsel bir amaç için nesne kullanımını, ikinci madde bilimsel problem karşısında duyarlılık derecesini, üçüncü madde öğrencinin teknik ürün tasarlamadaki yeteneğini, dördüncü madde öğrencilerin bilimsel hayal gücünü, beşinci madde yaratıcı bilimsel çözme yeteneğini, altıncı madde yaratıcı deneysel yeteneğin saptanması ve yedinci madde yaratıcı bilimsel ürün tasarlama becerisini ölçmek amaçlarıyla tasarlanmıştır.

Verilerin Analizi

Çalışmada kullanılan BYÖ ait öğrenci ifadeleri araştırmacılar tarafından kodlanmış, frekansları belirtilmiş ve puanlanmıştır (Hu ve Adey, 2002). Puanlama analizinin sonucunda öğrencilerin bilimsel yaratıcılık düzeylerinin belirlenmesi, deney ve kontrol gruplarının veri toplama araçlarından aldıkları puanlarının karşılaştırılmasında, aritmetik ortalama, standart sapma, ilişkisiz ve ilişkili örneklem t testi kullanılmıştır. Verilerin analizinde SPSS 17.00 paket programından yararlanılmıştır.

BULGULAR

Bu bölümde araştırmanın amacına uygun olarak belirlenen hipotezlere yanıt aramak üzere çeşitli istatistiksel teknikler kullanılarak elde edilen bulgulara ilişkin yorumlar yapılmıştır.

6. Sınıf Deney ve Kontrol Gruplarının Deneysel İşlemler Öncesi Bilimsel Yaratıcılık Puanları

Deneysel işlemlerin uygulanmasından önce 6. sınıf deney ve kontrol grubu arasında bilimsel yaratıcılık puanları bakımından bir farklılık olup olmadığına bakılmış, deney ve kontrol grubunun BYÖ'den aldıkları puanlar açısından denkliklerinin kontrolü yapılmıştır. Verilerin analizinde ilişkisiz örneklem t testi kullanılmıştır. Bulgular Tablo 1'de verilmiştir.

Tablo 1: 6. Sınıf Deney ve Kontrol Gruplarının Ön Test Bilimsel Yaratıcılık Puan Ortalamalarının Karşılaştırılması

BYÖ Puanları	N	\bar{X}	S	sd	p
6.Sınıf Deney Grubu Ön Test	20	50,25	16,43	19	,658
6. Sınıf Kontrol Grubu Ön Test	20	52,50	23,54		

Tablo 1'e göre 6.sınıf deney grubu öğrencilerinin bilimsel yaratıcılık toplam puan ortalaması ($\bar{X} = 50,25$), 6.sınıf kontrol grubu öğrencilerinin bilimsel yaratıcılık toplam puan ortalamaları ($\bar{X} = 52,50$) dir. $t(19) = -,450$ ve $p > 0.01$ olduğundan 6. sınıf deney ve kontrol gruplarının bilimsel yaratıcılık toplam puanları bakımından deneysel işlem öncesinde denk gruplar olduğu sonucuna ulaşılabilir.

6. Sınıf Deney ve Kontrol Gruplarının Deneysel İşlemler Sonrası Bilimsel Yaratıcılık Puanları

Deneysel işlemler uygulandıktan sonra 6.sınıf deney ve kontrol gruplarında ki öğrencilerin bilimsel yaratıcılık toplam puan ortalamaları arasındaki farka bakılmış ve farkın anlamlılığı test edilmiştir. Bulgular Tablo 2'de özetlenmiştir.

Tablo 2: 6. Sınıf Deney ve Kontrol Gruplarının Son Test Bilimsel Yaratıcılık Toplam Puan Ortalamalarının Karşılaştırılması

BYÖ Puanları	N	\bar{X}	S	sd	p
6. Sınıf Deney Grubu Son Test	20	109,30	26,88	19	,000
6.Sınıf Kontrol Grubu Son Test	20	64,45	20,04		

Tablo 2'ye göre 6. sınıf deney grubu son test bilimsel yaratıcılık toplam puan ortalamaları ($\bar{X} = 109,30$), 6.sınıf kontrol grubu son test bilimsel yaratıcılık toplam puanları ortalamaları ($\bar{X} = 64,45$) tir. $t(19) = 6,225$ ve $p < 0.01$ olduğundan bağımsız t testi sonuçları, bilimsel yaratıcılık toplam puanlarının laboratuvar deneyimleri uygulamaları ile oldukça anlamlı bir düzeyde arttığını açıkça göstermektedir. Tablo 1'deki veriler ile kıyaslandığında deney grubu süreç içerisinde bilimsel yaratıcılık toplam puan ortalamalarını 59,05 puan (109,30- 50,25) artırmışken kontrol grubu süreçte bilimsel yaratıcılık toplam puan ortalamasını 11, 95 puan (64,45- 52,50) artırabilmiştir. Bu sonuçta açık uçlu araştırma ve sorgulamaya dayalı laboratuvar deneyimlerinin etkililiği hakkında bilgi vermektedir.

8. Sınıf Deney ve Kontrol Gruplarının Deneysel İşlemler Öncesi Bilimsel Yaratıcılık Puanları

Deneysel işlemlerin uygulanmasından önce 8. sınıf deney ve kontrol grubu arasında bilimsel yaratıcılık puanları bakımından bir farklılık olup olmadığına bakılmış, deney ve kontrol grubunun BYÖ'den aldıkları puanlar açısından denkliklerinin kontrolü yapılmıştır. Verilerin analizinde ilişkisiz örneklem t testi kullanılmıştır. Bulgular Tablo 3'te verilmiştir.

Tablo 3: 8. Sınıf Deney ve Kontrol Gruplarının Ön Test Bilimsel Yaratıcılık Toplam Puan Ortalamalarının Karşılaştırılması

BYÖ Puanları	N	\bar{X}	S	sd	p
8.Sınıf Deney Grubu Ön Test	20	38,40	14,929	19	,954
8. Sınıf Kontrol Grubu Ön Test	20	38,65	14,177		

Tablo 3'e göre 8.sınıf deney grubu öğrencilerinin bilimsel yaratıcılık toplam puan ortalaması ($\bar{X} = 38,40$), 8.sınıf kontrol grubu öğrencilerinin bilimsel yaratıcılık toplam puan ortalamaları ($\bar{X} = 38,65$) dir. $t(19) = -,058$ ve $p > 0.01$ olduğundan 8. sınıf deney ve kontrol gruplarının bilimsel yaratıcılık toplam puanları bakımından deneysel işlem öncesinde denk gruplar olduğu sonucuna ulaşılabilir.

8. Sınıf Deney ve Kontrol Gruplarının Deneysel İşlemler Sonrası Bilimsel Yaratıcılık Puanları

Deneysel işlemler uygulandıktan sonra 6.sınıf deney ve kontrol gruplarındaki öğrencilerin bilimsel yaratıcılık toplam puan ortalamaları arasındaki farka bakılmış ve farkın anlamlılığı test edilmiştir. Bulgular Tablo 4'de özetlenmiştir

Tablo 4: 8. Sınıf Deney ve Kontrol Gruplarının Ön Test Bilimsel Yaratıcılık Puan Ortalamalarının Karşılaştırılması

BYÖ Puanları	N	X	S	sd	p
8.Sınıf Deney Grubu Son Test	20	82,95	16,337	19	,001
8.Sınıf Kontrol Grubu Son Test	20	66,45	15,826		

8. sınıf deney grubu son test bilimsel yaratıcılık toplam puan ortalamaları ($\bar{X} = 82,95$), 8.sınıf kontrol grubu son test bilimsel yaratıcılık toplam puanları ortalamaları ($\bar{X} = 66,45$) tir. (Tablo 4). $t(19) = 4,040$ ve $p < 0,01$ olduğundan bağımsız t testi sonuçları, bilimsel yaratıcılık toplam puanlarının laboratuvar deneyimleri uygulamaları ile oldukça anlamlı bir düzeyde arttığını göstermektedir. Tablo 3 teki veriler ile kıyaslandığında deney grubu süreç içerisinde bilimsel yaratıcılık toplam puan ortalamalarını 44,55 puan (82,95-38,40) artırmışken kontrol grubu süreçte bilimsel yaratıcılık toplam puan ortalamasını 25,80 puan (66,45-38,65) artırabilmiştir. Bu sonuçta 8. sınıf öğrencilerinin laboratuvar deneyimlerinin bilimsel yaratıcılıklarını artırmadaki etkinliği hakkında bilgi vermektedir.

6. ve 8. sınıflar Deney Gruplarının Bilimsel Yaratıcılık Ön ve Son Test Toplam Puan Ortalamalarının İncelenmesi

6. ve 8. sınıf öğrencilerin bilimsel yaratıcılık düzeylerini ön ve son testlere göre kıyaslayabilmek amacıyla ilişkili örneklem t testi kullanılmış ve sonuçlar Tablo 5'te özetlenmiştir.

Tablo 5: 6. ve 8.Sınıf Deney Gruplarının Ön ve Son Test Bilimsel Yaratıcılık Puan Ortalamalarının Karşılaştırılması

BYÖ Puanları	N	\bar{X}	S	sd	p	$\bar{X}_1 - \bar{X}_2$
6.Sınıf Deney Grubu Ön Test	20	50,05	16,433	19	,000	-59,25
6.Sınıf Deney Grubu Son Test	20	109,30	26,88			
8.Sınıf Deney Grubu Ön Test	20	38,40	14,929	19	,000	-44,55
8.Sınıf Deney Grubu Son Test	20	82,95	16,337			

Deneyel işlem başlamadan önce 6. sınıf deney grubunun bilimsel yaratıcılık toplam puan ortalamalarının 8. sınıf deney grubunun bilimsel yaratıcılık toplam puan ortalamasından daha yüksek olduğu yani BYÖ sonuçlarına göre 6. sınıfların bilimsel yaratıcılıklarının daha yüksek olduğu görülmektedir (Tablo 5). Açık uçlu araştırma ve sorgulamaya dayalı laboratuvar deneyimleri uygulamasıyla birlikte 6. ve 8. sınıf deney gruplarının ön ve son test toplam puan ortalamaları arasındaki fark incelendiğinde 6. sınıf deney grubunun bilimsel yaratıcılık son test toplam puan ortalamalarının 8. sınıf deney grubunun bilimsel yaratıcılık son test toplam puan ortalamalarından daha yüksek olduğu tespit edilmiştir. Süreçte 6. sınıf deney grubunun bilimsel yaratıcılık toplam puan ortalamalarını 59,25 puan artırmışken, 8. sınıf deney grubunun bilimsel yaratıcılık son test toplam puan ortalamalarını 44,55 puan artırdıkları gözlenmiştir.

TARTIŞMA VE SONUÇ

Deney ve kontrol gruplarının bilimsel yaratıcılık ön test puanlarında anlamlı bir fark bulunamazken açık uçlu araştırma sorgulamaya dayalı laboratuvar deneyimleri edinen deney grubu öğrencilerinin son test bilimsel yaratıcılık toplam puan ortalamaları kontrol grubu öğrencilerine göre anlamlı derecede farklılık göstermiştir. Çocukların yaratıcılıklarını geliştirmek için onları belirli kalıplara sokmadan özgür kalmalarına izin vermek ve onlara zenginleştirilmiş öğrenme ortamları hazırlamak gerekir. Her birey aslında yaratıcılık potansiyeli ile doğar. Önemli olan bu özelliği geliştirebilmektir (Fisher,1995; Lowenfeld, 1953). Çocukların bilimsel yaratıcılıklarını geliştirmek için açık uçlu araştırma ve sorgulamaya dayanan laboratuvar deneylerinin kullanılmasında bu faktörler etkili olmuştur. Yaratıcılığın sadece özel yetenekleri olan bireylere özgü bir özellik olduğu fikrinden uzaklaşarak öğretmenlerin yaratıcılık hakkındaki inanç ve eğitimleri desteklenmelidir. Haigh (2007), yapmış olduğu çalışmada uzun süreli laboratuvar etkinliklerinin öğrencilerin yaratıcılıklarını gelişiminde daha etkili olduğunu ifade etmiştir. Bu çalışmada Haigh'in çalışmasını destekler nitelikte sonuçlar elde edilmiştir. Ayrıca yaratıcılığın gelişmesi için belirli bir süreye de ihtiyaç vardır. Graham Wallis yaratıcılığın dört aşamalı bir süreç olduğunu tespit ederek(Lytton, 1971), bu süreyi yaratıcılığın dört aşamasından biri olan kuluçkaya yatırma aşaması ile açıklamıştır. Öyle ki alan yazındaki bilimsel yaratıcılığın geliştirilmesine yönelik bazı çalışmalarda anlamlı bir farklılık bulunamamıştır (Şahin Pekmez, Aktamış, Can, 2010; Kaptan ve Kuşakçı, 2001).

6. ve 8. sınıf deney gruplarının ön test toplam puanları incelendiğinde 6. sınıf öğrencilerinin bilimsel yaratıcılık düzeylerinin 8. sınıf öğrencilerinin bilimsel yaratıcılık düzeylerinden daha yüksek olduğu ve 6. sınıf deney grubunun bilimsel yaratıcılık toplam puanlarını 8. sınıf deney grubuna göre daha fazla artırdığı gözlemlenmiştir. Torrance (1962) yaratıcılıktaki bu düşüşlerin erinliğin fizyolojik değişimleri sonucu ortaya çıkan çatışmalardan kaynaklandığını ifade etmiştir (Torrance, 1962, s: 94-95; akt Öncü, 2003). Ayrıca 8. sınıf öğrencilerinin merkezi sınava hazırlanmaları sonucu yaşadıkları kaygılarda bu düşüşe sebep olmuş olabilir.

Hem deney hem de kontrol gruplarının süreç sonunda bilimsel yaratıcılık toplam puanlarının arttığı gözlenmiştir ancak deney gruplarındaki pozitif artış dikkat çekmektedir. Wallace Tsoi, Calkin ve Darley (2003)' in yürüttükleri bir araştırmada öğrencilerin açık uçlu deneyleri tercih ettiklerini belirtmişlerdir. Deney gruplarında öğrenciler açık uçlu araştırma ve sorgulamaya dayalı laboratuvar deneyimleri edinmiş olmakla birlikte kontrol grupları da derslerde laboratuvar kullanmış ancak deneyler kapalı uçlu, öğretmen denetiminde ve genellikle gösteri deneyleri şeklinde yürütülmüştür ve her iki yöntemde de bilimsel yaratıcılığın geliştirilebildiği görülmüştür. Aydın Ceran, Çavuş Güngören ve Boyacıoğlu (2014)'nun yapmış oldukları bir tarama çalışmasında deney ve etkinlik ağırlıklı ders işlediklerini belirten öğrencilerin bilimsel yaratıcılık düzeylerinin daha yüksek olması da bu çalışmanın sonuçlarını destekler niteliktedir.

KAYNAKÇA

- Aydın Ceran, S., Çavuş Güngören, S., Boyacıoğlu, N. (2014). Determination of scientific creativity levels of middle school students and perceptions through their teachers. *European Journal of Research on Education, 2014, Special Issue: Contemporary Studies in Education, 47-53.*
- Deniş Çeliker, H., Balım, A.G. (2012). Bilimsel Yaratıcılık Ölçeğinin Türkçeye Uyarlama Süreci ve Değerlendirme Ölçütleri. *Uşak Üniversitesi Sosyal Bilimler Dergisi 5, 1-21.*
- Fisher, R. (1995). Teaching Children to Think UK, Stanley Thornes (Publishers) Ltd.
- Haigh, M. (2007). Can Investigative Practical Work in High School Biology Foster Creativity? *Journal of Research in Science Education, 37, 123-140.*
- Hu, W. & Adey, P. (2002). A scientific creativity test for secondary school students. *International Journal of Science Education, 24, 389-403.*
- Kaptan, F. ve Kuşakcı, F. (2001). *Fen öğretiminde beyin fırtınası tekniğinin öğrenci yaratıcılığına etkisi.* V. Ulusal Fen Bilimleri ve Matematik Eğitimi Kongresi, ODTÜ-Ankara.
- Lee, M.K., & Erdogan, I. (2007). The effect of science–technology–society teaching on students' attitudes toward science and certain aspects of creativity. *International Journal of Science Education, 29, 1315-1327.*
- Lowenfield, V. (1953). *Education and Art: A symposium*, Lausanne: Unesco.
- Lytton, Hugh. (1971). *Creativity And Education*. London: Routledge & Kegan Paul Pub.
- MEB, (2013). *Fen bilimleri dersi öğretim programı*, Ankara.
- Noiwong, W., Phinyocheep, P. (2012). Promoting secondary students' understanding of scientific concepts through a guided-inquiry laboratory : Polymers and their properties” *The International Journal of Learning, 18(10), 327-343.*
- Öncü, T. (2003). Torrance yaratıcı düşünme testleri-şekil testi aracılığıyla 12-14 yaşları arasındaki çocukların yaratıcılık düzeylerinin yaş ve cinsiyete göre karşılaştırılması. *Ankara Üniversitesi Dil ve Tarih Coğrafya Fakültesi Dergisi, 43, 221-237.*
- Şahin Pekmez, Esin, Aktamış, H., Can, B. (2010). The Effectiveness of Science Laboratory Course Regarding the Scientific Process Skills and Scientific Creativity of Prospective Teachers. *INONU UNIVERSITY JOURNAL OF THE FACULTY OF EDUCATION, Volume. 11, Issue. 1, pp. 93-112.*
- Torrance, E. P. (1962). *Guiding creative talent*. Englewood Cliffs, NJ: Prentice-Hall.
- Wallace, S. C., Tsoi, M. Y., & Calkin, J. D. M. (2003). Learning from Inquiry-Based Laboratories in Nonmajor Biology: An Interpretive Study of the Relationships among Inquiry Experience, Epistemologies and Conceptual Growth. *Journal of Research in Science Teaching, 40(10), 986-1024.*

BİLİMSEL SÜREÇ BECERİLERİ ETKİNLİKLERİNİN ORTAOKUL ÖĞRENCİLERİNİN BİLİMSEL BİLGİYE YÖNELİK GÖRÜŞLERİNE ETKİSİ

THE EFFECT OF SCIENTIFIC PROCESS SKILLS ACTIVITIES ON MIDDLE SCHOOL STUDENTS' VIEWS ABOUT SCIENTIFIC KNOWLEDGE

Cennet YILDIRIM
MEB
daughter_of_heaven@hotmail.com

Bilge CAN
Pamukkale Üniversitesi
bilgeta@hotmail.com

ÖZET: Bilimsel bilgi kavramına yönelik görüş, bireylerin bilginin ne olduğu, bilme ve öğrenmenin nasıl gerçekleştiği ile ilgili inançları olarak tanımlanmaktadır. Bilimsel süreç becerilerine sahip bir birey problem çözme becerilerine sahip, etrafında gelişen olaylara anlam katabilen akılcı bir bireydir. Bu tür bireylerin yetişmesine fen dersinin katkısı çok büyüktür ve fen öğretmenleri bu konuda çok önemlidir. Çalışmanın amacı, ortaokul 6. sınıf öğrencilerinin “Madde ve Isı” ünitesine yönelik hazırlanan bilimsel süreç becerileri etkinliklerinin bilimsel bilgiye yönelik görüşlerine olan etkisini belirlemektir. Çalışmada öntest-sontest kontrol gruplu deneme modeli kullanılmıştır. Araştırmanın çalışma grubunu, 2013-2014 eğitim öğretim yılında Manisa ili Sarıgöl ilçesi Atatürk Ortaokulu’nda öğrenim görmekte olan elli altıncı sınıf öğrencisi oluşturmaktadır. Araştırmada öğrencilerin bilimsel bilgiye yönelik görüşlerini belirlemek üzere “İlköğretim Öğrencilerinin Bilimsel Bilgiye Yönelik Görüşlerini Belirleme Ölçeği” kullanılacaktır. Bunun yanında hem deney hem de kontrol grubundan 3’er öğrenciyle uygulama öncesi ve sonrasında bilimsel bilgiye yönelik yarı yapılandırılmış görüşme yapılacaktır.

Anahtar sözcükler: Bilimsel Bilgiye Yönelik Görüş, Bilimsel Süreç Becerileri, Ortaokul Öğrencileri, Fen Öğretimi

ABSTRACT: Views about concept of scientific knowledge is defined as individuals’ beliefs about what knowledge is and about how knowing and learning occur. A person who has scientific process skills has problem solving skills and can give meaning to the events surrounding his/her and is rational. Contributions of science lessons are enormous to growth of these kinds of individuals and science teachers are very important in this regard. The purpose of this study is to determine the effect of scientific process skills that prepared for the unit of “Matter and Heat” on middle school sixth grade students’ views about scientific knowledge. In the research, the pre-test post-test experimental model was used. The participants of the research were 50 sixth grade students attending to a state middle school in Manisa/ Sarıgöl Atatürk Middle School during 2013-2014 instructional year. In the research, to determine students’ views about scientific knowledge “The Instrument for Determining the Views of Primary School Students about Scientific Knowledge” will be used. Besides that, 3 student from both experimental and control group will be done semi-structured interview before and after the instruction about the scientific knowledge.

Key words: Views About Scientific Knowledge, Scientific Process Skills, Middle School Students, Science Education

ENHANCING STUDENT LEARNING THROUGH USE OF ONLINE TECHNOLOGIES

Zeynep YURTSEVEN AVCI

This study focuses on using communication and collaboration technologies to facilitate and empower student learning of authentic mathematics problems. Two teachers and 35 students at a U.S. public high school participated in this study. A specific curriculum, which is called MINSET (Mathematics INstruction using Decision Science and Engineering Tools), was chosen for this study consists of contextual problems from business as well as from students' lives that employ multi-step mathematical problem-solving techniques to solve and interpret real life situations. Students were introduced two online technologies, Voice Threads and Google Documents, to practice problems, homework, and projects. This research has been designed using qualitative case study method. Data was collected through classroom observations, student and teacher interviews, and teacher reflections. Data was analyzed by open coding applying content analysis method. Results of this research suggest that using online technologies for communication and collaboration purposes might have potential to enhance student learning. Most of the students had positive perceptions about the impacts of using online technologies on their comprehension of the contents of the classes. Some students had also critiques about using online tools in their mathematics class. The reasons of positive perceptions and critiques by students; and teacher perceptions about the impacts of using online tools on student learning were analyzed in detail. It can be concluded that communication and collaboration with peers supported deepening of students' conceptual understanding by providing them access to each other's theories and perspectives on the mathematical problems posed. Students' 21st century skills were strengthened by using contemporary forms of communication and collaboration, participating in discussions, questioning each other's theories, and comparing ideas in the community of practice that they developed in online platforms.

Keywords: Online Tools, Mathematics Education, Collaboration

AN EXAMINING OF MIDDLE SCHOOL STUDENTS' SELF-EFFICACY TOWARD GEOMETRY AND ATTITUDES TOWARDS MATHEMATICS

Hatice AÇAN

Graduate Student, Institute Of Education Sciences, Dokuz Eylul University, Izmir, Turkey.

Büşra ŞAHİN

Graduate Student, Institute Of Education Sciences, Dokuz Eylul University, Izmir, Turkey.

Sevde ÖZBAY

Graduate Student, Institute Of Education Sciences, Dokuz Eylul University, Izmir, Turkey.

Berna CANTÜRK GÜNHAN

Assistant Professor, Department of Elementary Mathematics Education, Dokuz Eylul University, Izmir, Turkey.

ABSTRACT: The readiness must be enough in order to students can learn a new topic in mathematics and geometry courses and to make sense in the mind. Therefore, one of the most important aspects of readiness students' attitudes towards courses and self-efficacy beliefs should be high. Hence this research is made to determine self-efficacy of the middle school students toward geometry and attitude level for mathematics. The present study aims to reveal if the middle school students' self-efficacy toward geometry and attitude for mathematics differentiates in terms of gender, grade level and their latest math grades. The universe of the current study is composed of the students from secondary schools in Izmir studying in the 2013-2014 academic year. And the sample is consist of 294 randomly selected students including 52 from the 5th grade level, 84 from 6th grade level, 93 from 7th grade, 65 from 8th grade level. The data were collected through the "Geometry Self-Efficacy Scale" improved by Cantürk-Günhan (2006) and the "Scale of Attitudes towards Mathematics" by Nazlıççek ve Erkin (2002) demographic information form designed by the researchers. For data analysis, t-test, analysis of variance, correlation ve regression analyzes methods were used. According to the findings; it was determined that there is no significant difference in geometry self- efficacy of students according to gender variable whereas the present study shows significant difference in attitude among gender variable and according to grade level between attitudes and self-efficacy beliefs. According to research findings there is significant relationship between self-efficacy, attitudes and mathematics achievement also self-efficacy and attitudes has been identified as predictors of mathematics achievement. Findings support the importance of students self-efficacy and attitude on their academic achievement thus several suggestions were made according to research findings.

Keywords: Attitude Towards Mathematics, Geometry Self- Efficacy , Mathematics Achievement, Elementary School Students

THE EXPERIENCE OF TEACHING STATISTICS TO NON-SPECIALIST STUDENTS IN SAUDI UNIVERSITIES: THE ROLE OF TECHNOLOGY AND LANGUAGE

Abdullah ALOMIR
University of Glasgow
a.al-omir.1@research.gla.ac.uk

John H. MCCOLL
University of Glasgow
John.McColl@glasgow.ac.uk

Catherine BOVILL
University of Glasgow
Catherine.Bovill@glasgow.ac.uk

ABSTRACT: The importance of statistics is not limited to statisticians but also impacts on non-statisticians who have to use statistics. One important issue is how statistics is best taught to, and learned by, non-specialist students. The pervasive use of the English language causes additional challenges to learners whose first language is not English, especially when technological resources that use English language, such as statistics software packages, are an integral part of the course. This paper presents research into the current position in Saudi universities, where there has previously been a lack of research into this topic. Mixed methods research has been used: a questionnaire survey of 1,053 students and qualitative interviews with 16 teachers of statistics from all colleges within all six universities where statistics is taught to non-specialist students in Saudi Arabia's Eastern Region. This presentation will discuss differences between the experiences of learners taught in the Arabic and English languages.

Key words: Language in Statistics, Introductory statistics course, Non-specialist students, Statistical software packages; Saudi Arabia.

INTRODUCTION

With the continuing development of statistics as an independent discipline, the number of researchers and those interested in this discipline continues to increase. The need to learn statistics is not limited only to statisticians but also includes non-statisticians in various disciplines who use statistics within their fields, and this has made the teaching of statistics more complex. Therefore, one important issue that requires attention by researchers and those interested in the field of educational statistics is the teaching of statistics to non-specialist students (Garfield and Ben-Zvi 2007, Simpson 1995).

Research and studies related to the teaching and learning of statistics to non-specialist students are only beginning to emerge. Some of the most important topics in this research area which will be discussed in this paper are the impact of English language in learning and teaching statistics to non-specialist students whose first language is not English and how language can affect students' use of technological resources such as statistics software packages in statistics courses.

English Language in Learning and Teaching Statistics

Language plays a crucial role to connect parts of the educational process but sometimes it can be an obstacle for students. Usually, disciplines use specific terminologies which are unknown to junior students or those who are unfamiliar with the discipline. Also, many students who learn subjects in a second language have usually faced some difficulties with the language. Furthermore, printed and online reading resources and software tools which are used in the study of statistics are often not available in languages other than English. Students may face difficulties in their courses in trying to overcome these problems.

The language which is used in teaching statistics is one of most important factors that may help students to understand statistics courses. The use of technical words in teaching statistics to beginner students, particularly students from a non-English Speaking Background (NESB) who have a limited level of language skills, may lead these students to believe statistics courses are more difficult than they really are (Kaplan et al. 2009). Some

technical words used in statistics do not exist in all languages and some of them are not fully explained in the dictionaries (Abdelbasit 2010; Hubbard 1990). Moreover, in statistics there is often more than one meaning indicated by one word and in addition, there are several words used to imply one meaning, and this can add to student confusion. For instance, teachers often use "normally" and it does not necessarily relate to "normal distribution" but may relate to another meaning. Also teachers use "average" and sometimes "mean" and both can relate to the same concept. Kaplan et al. (2009) mention that "The use of domain-specific words that are similar to commonly used English words, therefore, may encourage students to make incorrect associations between words they know and words that sound similar but have specific meanings in statistics that are different from the common usage definitions" (p. 2). This can delay or reduce students' understanding of lectures.

Many difficulties that may face students when they use the English language in their studies need to be considered by teachers when designing statistics courses for non-specialists. One of these difficulties is that students need more time in lectures to understand the subject and this may cause the loss of students' attention. Students in many countries also rarely use English outside the classroom, so their level of English language does not improve as much as those students living in English-speaking countries (Abdelbasit 2010).

Technology in Learning and Teaching Statistics

In recent years, technology has become a major influence upon student learning of statistics because of the rapid development of a range of different technologies. At the moment, we cannot imagine that the process of learning and teaching statistics does not include technology because it has become an integral part of teaching. Statistical problems and calculations used to be calculated by hand and by calculator, but technology has changed this and thus approaches to teaching statistics have also needed to change (Chance et al. 2007). In previous years, teachers needed more time to explain new statistical concepts to students in the classroom and some statistical problems and analyses took more time to complete. This situation has changed because technology has provided us with many modern methods and tools to demonstrate these concepts better (Good 2006).

Technology has helped many teachers to teach statistics and it has also helped many students to learn statistics. Chance et al (2007) argue that the use of technology can benefit students through them being able to: collect data on a large-scale and deal with it more accurately; undertake statistical procedures and operations automatically; obtain the results and statistical interpretations more easily and display them with more clarity. These benefits can contribute to building confidence among students during their study of statistics and can encourage and motivate them to learn statistics (Good 2006).

This study examines the role played by English language in teaching statistics to non-specialist students (especially NESB students), and how the language used in teaching affects the use of technology in statistics in Saudi Arabian universities. This paper will discuss differences between the experiences of non-specialist students in Saudi universities taught in the Arabic and English languages.

METHODS

Mixed methods research is used in this study. Quantitative data allows the researcher to gather data from a large number of participants while qualitative data provides in-depth information from a smaller group of participants. Both quantitative and qualitative data complement each other in this study.

The first method of data collection (questionnaire) was used to collect data from non-specialist students who had completed at least one statistics course in different disciplinary colleges of the six universities in the Saudi Arabian Eastern Region. The instrument was designed to identify the current state of learning and teaching statistics for non-specialist students in Saudi universities. The instrument has thirty-one closed questions using yes/no and Likert scale responses, Strongly Disagree (SD), Disagree (D), Neutral (N), Agree (A), Strongly Agree (SA), as well as some open ended questions. The second method of data collection (interview) was used with teachers of statistics who teach statistics courses to non-specialist students in these colleges.

Because of limitations of cost and time affecting the data collection phase of the study, the researcher decided to collect the data from the eastern region of Saudi Arabia as a sample for this study. The eastern region is considered the largest province and covers 33% of the entire area of the country. Also, the population of the region represents 15.6% of the country's total population and, because of its location on the coast of the Arabian Gulf, the people who live in the eastern region represent a mixture of all of the groups in Saudi Arabia. Through the previous justifications, non-specialist students and teachers of statistics courses in the six universities in eastern region, which represent 18.2% of universities in Saudi Arabia and 100% sampling of universities in this

region, are the research study population and also provide the researcher with a realistic representation about other universities in Saudi Arabia. The researchers have chosen not to identify the specific institutions at this stage of the analysis.

Sampling

The 16 disciplinary colleges within the six universities in eastern region and 39 academic departments which form most of the academic departments within these colleges where statistics courses are taught to non-specialist students were identified. Then, one suitable class from each academic department was randomly selected and the study aimed to obtain 100% response rate from the study population (students) in these classes for two reasons; first, in order for this study to be more realistic and credible. Second, the last 15 minutes of lectures in these classes were used by the researcher to distribute the questionnaires to students participating in the study, so it was considered unjustified to include some students and not others. Therefore, questionnaires were distributed to every student present in the classes.

When the researcher (AA) entered the classrooms, he introduced himself to the students and briefly explained four important points: students who participated in the study would have to have completed at least one course in statistics, their participation would be voluntary and they were to make sure that they answered the questionnaire as realistically and honestly as possible. Finally, he informed them that all of the information in the questionnaires would be treated confidentially and would be used for research purposes only. He then distributed the questionnaires to every student in each classroom, regardless of the number of students, and so this is the main cause of variation in the number of participants in the various academic departments. The researcher stood at the front of the room until the students had finished filling in the questionnaires, which he then collected from them. The total number of responses from students in this study was 1053 non-specialist students.

To conduct the study of statistics teachers who teach non-specialist students from the six universities being studied, 16 statistics teachers who teach non-specialist students were randomly selected from most of colleges within these universities where statistics is taught to non-specialist. The interviews took 20-35 minutes for the teachers to answer all the questions.

Data analysis methods

The questionnaire contained questions asking respondents to rate their own English language abilities for four skills – reading, writing, listening and speaking – each at one of three levels – Excellent (scored 1), Good (2) or Poor (3). Cross-tabulations and chi-square tests were conducted to identify the level of association between these skills. The associations were very strong and the chi-square tests gave highly significant results, so the mean value of the four scores was calculated and rounded to give an integer-valued overall score for English language skill of 1, 2 or 3 with 3 representing the poorest level of ability.

Several questions had a ‘not applicable’ response option; ‘not applicable’ responses were discounted from the analysis. Seven questions using Likert scales phrased in a negative direction were reverse coded before being analysed.

Because there are many individual questions in the questionnaire, with substantial associations expected among them, factor analysis was conducted for dimension reduction. It was anticipated that the large number of observed items would represent a much smaller number of underlying factors, including the influences of English language and technology use. Cross-tabulations and chi-square tests were then used to explore the relationships between factor scores and background variables, including the main language used for teaching the statistics course (Arabic or English) and the student’s level of English language skill.

RESULTS AND FINDINGS

The-Kaiser-Meyer-Olkin measure verified the sampling adequacy for the factor analysis, KMO=0.82 overall and > 0.6 for individual items, which is well above the acceptable limit of 0.5. Bartlett’s Test of Sphericity, chi square = 4718.69, $p < .001$, indicated that correlations between items might be sufficiently large to make factor analysis useful. Five factors were identified with eigenvalues over Kaiser’s criterion of 1, which in combination explained 57.28% of the variance. These factors were interpreted as: (1) Effectiveness of Teachers, (2) English Language, (3) Relevance of Course, (4) Students Engagement and (5) Using Technology. This paper will focus on Factor 2 (English Language) and Factor 5 (Using Technology). Items contained in these factors are listed in

Table 1 and the frequencies of responses for these items after reverse coding (as necessary) are shown in Table 2 below. For each factor, an overall score was obtained by taking the mean value of all the completed items involved in that factor, then rounding the mean to an integer value of 1, 2, 3, 4 or 5 with 5 being the most positive response.

Table 1. Items Contained in Factors 2 and 5

Factor 2 (English Language)	Factor 5 (Using Technology)
Q34. Some statistical technical words which are not translated into my language make it difficult for me to learn statistics. (reverse coded) Q35. Most statistical software programs are in English and this makes it difficult to learn statistics. (reverse coded) Q36. My lack of English language skills is an obstacle to me using statistical software programs. (reverse coded) Q37. My level of English language skills has prevented me from accessing statistics resources and references in the English language. (reverse coded)	Q26. The teacher used technology (e.g. PowerPoint, the internet, statistical packages) effectively to help teach this course. Q27. Using a statistical software program led me to concentrate on the technology and not the statistical concepts being taught. Q28. Using a statistical software program to compute the statistical problems caused me misunderstanding of some steps of statistical procedures. Q29. Enough time was spent in learning and using a statistical software program. Q30. I could have used technology to learn statistics just as effectively without the teacher.

Table 2. Frequencies of Responses for Items in Factors 2 and 5

Factor 2 (English Language)						Factor 5 (Using Technology)							
	SD	D	N	A	SA	All		SD	D	N	A	SA	All
Q34	111	218	227	257	163	976	Q26	214	122	83	264	241	924
Q35	86	180	203	215	198	882	Q27	190	212	233	140	57	832
Q36	119	203	166	240	188	916	Q28	143	236	210	160	57	806
Q37	130	194	177	242	194	937	Q29	189	202	208	177	47	823
							Q30	169	194	236	248	77	924

Comparison of Universities

In this section we summarize the abilities of students in the English language and describe the overall picture of their responses for Factors 2 and 5, depending on which university they were attending. Within the universities (1, 5 and 6) that used English as the main language for teaching, most students classified themselves in the first and second level (excellent and good) of English language skills. The highest rates were for universities 5, 1 and 6 respectively. After that came universities 2 and 3, where some of the colleges used English and the others used Arabic, then university 4, which used Arabic as the main language and where most students claimed to have poor English skills. Scores for Factor 2 showed that the majority of students in universities 1 and 5 had a positive experience of the way English was used in their statistics courses. After that came students in universities 6, 2 and 3 respectively, but the majority of students in university 4 felt that the use of English impacted negatively on their study of statistics. Furthermore, the scores for Factor 5 reveal that universities 5 and 1 also had the highest rates of satisfaction among students towards the use of technology in studying statistics, then came universities 2 and 3. In universities 6 and 4, the majority of students were dissatisfied with the use of technology. Despite the results for the other universities, it is perhaps surprising that in university 6, although English is the main language of instruction, the majority of students were dissatisfied with the use of technology in studying statistics.

English Language (Factor 2)

Figure 1 compares the distribution of Factor 2 (English Language) scores for students who were taught statistics in Arabic and English. 34% of students who were taught in Arabic had a negative experience of the impact of English on their study of statistics (factor scores of 1 or 2) whereas 32% of them had a positive experience (scores of 4 or 5). However, 58% of students who studied statistics in English had a positive experience and only 18% of them a negative experience. A chi-square test of association between language of instruction and Factor 2 score was significant: $\chi^2(4, N = 1010) = 78.96, p < .005$. The association was of moderate strength, Cramer's $V = 0.28$.

Figure 2 compares the distribution of Factor 2 (English Language) scores for students who reported different levels of skill in English. Within level 1 (Excellent) in English language skills, almost 75% of students had a positive experience of the use of English in their study of statistics (scores of 4 or 5), while 18% were neutral and 7% of them had a negative experience. On the other hand, pupils whose English skills are at level 3 (Poor),

49% found that the English language negatively affected their study of statistics. A chi-square test of association between level of English language skill and Factor 2 score was significant: $\chi^2(8, N = 1010) = 227.57, p < .005$. The association was of moderate strength, Cramer's $V = 0.34$.

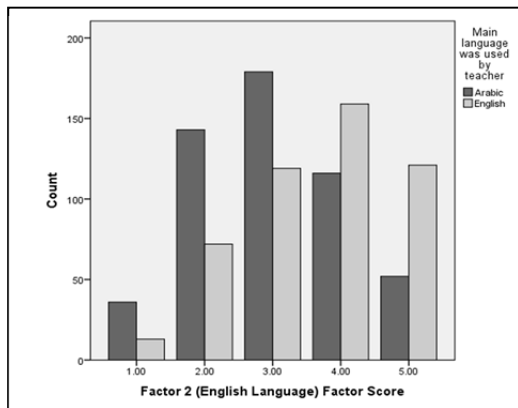

Figure 1. Frequencies of Factor 2 (English Language) Scores for Students Taught in Arabic and English Skills

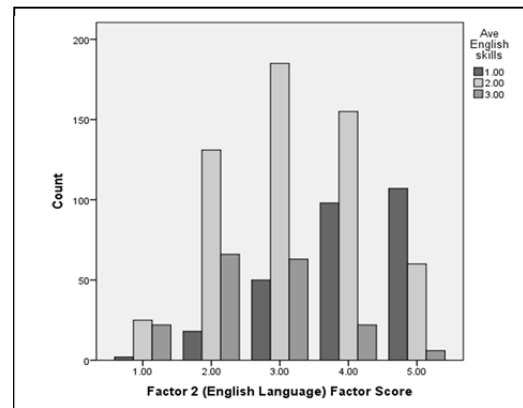

Figure 2. Frequencies of Factor 2 (English Language) Scores for Students with Different Levels of English Language

Using Technology (Factor 5)

Figure 3 compares the distribution of Factor 5 (Using Technology) scores for students who were taught statistics in Arabic and English. When English was the main language of the course, 20% of students were dissatisfied with the use of technology (scores of 1 or 2) and 26% of them had positive satisfaction (scores of 4 or 5). Of students who studied the statistics course in Arabic, 46% were dissatisfied and 18% positively satisfied. A chi-square test of association between language of instruction and Factor 5 score was significant: $\chi^2(4, N = 1002) = 76.29, p < .005$. The association was of moderate strength: Cramer's $V = 0.28$.

Figure 4 compares the distribution of Factor 5 (Using Technology) scores for students who reported different levels of skill in English. Among students whose English language skills were excellent (level 1), 21% had negative responses (factor scores of 1 or 2) regarding the use of technology in their statistics course compared to 25% who had a positive response (scores of 4 or 5). On the other hand, 46% of students whose English level was poor (level 3) were not satisfied and just 17% were positively satisfied. A chi-square test of association between level of English language skill and Factor 5 score was significant: $\chi^2(8, N = 1002) = 33.18, p < .005$. The association was of weak strength, Cramer's $V = 0.13$.

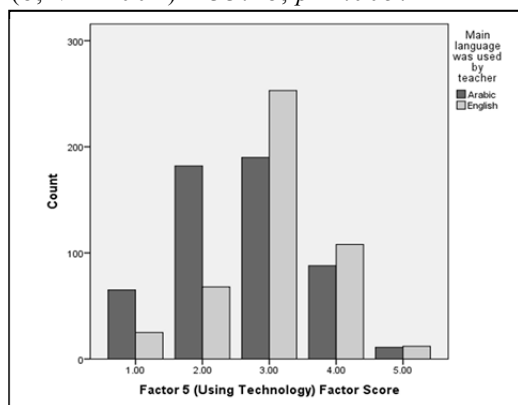

Figure 3. Frequencies of Factor 5 (Using Technology) Scores for Students Taught in Arabic and English

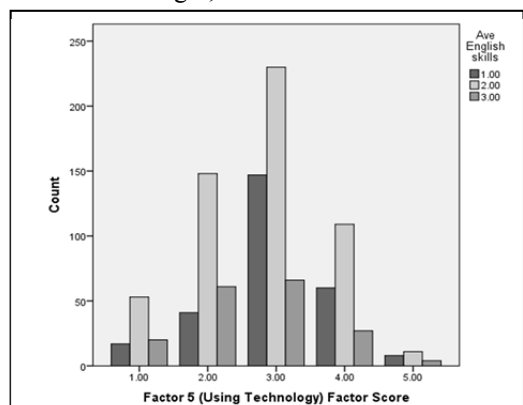

Figure 4. Frequencies of Factor 5 (Using Technology) Scores for Students with Different Levels of English Language Skills

Teachers' Interviews

Analysis of the staff interviews is at an early stage, but some themes related to this paper are already emerging. In using technology, almost all the teachers are using PowerPoint and the Internet for teaching statistics. Most of the interviewees are using statistical software in their teaching (3 are not) and the following packages are mentioned: Excel, SPSS, Matlab, Minitab, Statistica and SAS. Lack of technical facilities and support staff and large class sizes are the main challenges that face teachers who try to use technology in teaching statistics.

Concerning the influence of the students' limited English language skills on their study of statistics, teachers were divided into two groups based on their opinions. Teachers in group one said there are no problems relating to this issue. For example, teachers 1, 2 and 12 find that there is no effect of English in studying statistics; as Interviewee 1 said, "There is no significant effect because Statistics does not require students to have a good command of English language". The student questionnaires on the other hand revealed that the majority of students in the same colleges as these members of staff have negative responses regarding to the influence of English in their study of statistics. The rest of the teachers in this first group explained that the lack of impact of the English language on studying statistics is due to the good English skills of their students; as Interviewee 8 said, "This problem does not affect students' learning of Statistics in this university because the course is 100% taught in English. The fact that the teacher's mother tongue is Arabic may drive him to spontaneously use some Arabic words in the lecture, though the use of Arabic is not encouraged". The second group of teachers argue that the limited English language skills of students, does affect their study of statistics, whether they used Arabic or English as the main language. For instance, Interviewee 15 said, "I often find in exams that the most common errors in the answer sheet result from students' incorrect understanding of the questions, which affects their final results. The students themselves admit that their level in the English language is not good enough to understand the exam questions". Also, Interviewee 16 mentioned that, "Sometimes, I imagine that were the teaching of Statistics in Arabic, students' understanding would be much better. In general, the English language stands as a stumbling block to students' learning."

CONCLUSION

Most statistical software packages and their commands are in English. Text books, websites, lectures on YouTube and other available statistics resources are mainly in the English language and significantly outweigh resources available in Arabic. Consequently, as we can see from the data presented here, many of the non-specialist students in Saudi Arabia's Eastern Region who are taught statistics courses in Arabic have encountered challenges and difficulties in using technology in statistics courses, and most of the students taught in Arabic agree that the English language is an obstacle to their study of statistics. Conversely, the majority of students who are taught a statistics course in English have found that English language was very useful for them and supported them in learning statistics and in dealing with technology. High percentages of students who reported that there were no challenges in using technology were also those students who described their English language ability as excellent. This suggests that English language skills play a key role among non-specialist students in their studying of statistics courses. Our future analysis will include examining whether the type of university is related to the decision about what language is used to teach statistics teaching, and whether student capabilities in particular institutions are related to language skills.

To maximise the benefits of studying statistics for non-specialist students in Saudi Arabia's higher education institutions, the administrators and teachers of statistics in these institutions need to consider several things. First, for institutions that use English language in teaching statistics, they have to be sure that their students' English language skills are sufficient in order for English not to be an obstacle to them. In these institutions as well as in institutions that use Arabic for teaching statistics courses, institutions need to consider teaching some supplementary English language covering relevant statistical terminology to assist students to use more statistics resources that can enhance their use of technology, support student learning through making studying statistics easier. It is also necessary to help students by teaching them the basic skills to use statistical software programmes (Simpson 1995). In designing assessments in English and Arabic, it is important that questions are stated as clearly and unambiguously as possible, and with cognisance of the potential for students to misunderstand statistical terms that are not clearly stated. Where students have good English language skills, teachers should be encouraged to use the good range of statistics resources available in the English language to benefit students. Finally, it is very important for institutions to encourage statistics specialists and researchers to write and translate statistics books into Arabic and create online resources to provide a better range of references for non-specialist students studying in Arabic.

- Abdelbasit, K. M. "Teaching Statistics in a Language Other Than the Students'." *Presented at Data and Context in Statistics Education: Towards an Evidence-Based Society. Proceedings of the Eighth International Conference on Teaching Statistics. Voorburg, The Netherlands: International Statistical Institute.* <http://www.stat.auckland.ac.nz/~iase/publications.php>.
- Chance, B., Ben-Zvi, D., Garfield, J., and Medina, E. (2007). "The Role of Technology in Improving Student Learning of Statistics."
- Garfield, J., and Ben-Zvi, D. (2007). "The Discipline of Statistics Education." http://www.ugr.es/~icmi/iase_study/BackgroundpaperGarfield.pdf.
- Good, P. (2006). *Resampling Methods*: Birkhauser.
- Hamadu, D., Adeleke, I., and Ehie, I. (2011). "Using Information Technology In Teaching Of Business Statistics In Nigeria Business School." *American Journal of Business Education (AJBE)*, 4(10), 85-92.
- Hubbard, R. (1990). "Teaching Statistics to students who are learning in a foreign language." *ICOTS 3*, 514 – 517.
- Kaplan, J. J., Fisher, D. G., and Rogness, N. T. (2009). "Lexical ambiguity in statistics: What do students know about the words association, average, confidence, random and spread." *Journal of Statistics Education*, 17(3), n3.
- Simpson, J. M. (1995). "Teaching statistics to non-specialists." *Statistics in medicine*, 14(2), 199-208.

MODERN ICT SOLUTIONS TO BE TAUGHT IN TOURISM AND HOSPITALITY EDUCATION: EVALUATION AND IMPLICATIONS

Edina AJANOVIC
Institute of Social Sciences Akdeniz University
edinaajanovic@akdeniz.edu.tr

ABSTRACT: While there are still short terms courses or one semester teaching on how to use software solutions for property management, technology continues with its rapid development. Introduction of cloud computing had a major impact on almost all sectors that are using ICT services and solutions. In tourism and hospitality industry cloud technology has made a revolution and moved their property management systems online.

It is necessary for tourism educational institutions to include the lessons of ICT usage into their academic curriculum. This is considered as a possibility for students to learn about modern ICT solutions, accept changeable nature of it and get better preparation for the real business world. In this study, current program for teaching desktop solutions and ICT developments in tourism and hospitality were analyzed and compared with new, web-based solutions and teaching methods. Implications on how this topic might be useful for all interested parties in education process were derived.

Key words: Cloud computing, Teaching ICT in tourism and hospitality, ICT practice

INTRODUCTION

According to Cohen (1997) technology-rich classrooms enable more fluid social interaction between teachers and students, making learning a more natural process. Technology enhanced education in classroom is still based on traditional teaching methods in terms of class meetings and faculty lectures. However, technology plays significant role inside and outside the classroom through Power point presentations, online material, computer simulations CD-ROMs, etc. When it comes to topic of teaching and learning usage of modern ICTs (information and communication technologies), it is still not implemented and realized in its full potential. It is based on overview and display of teaching materials and ideas usually involving passive communication with the students. Teaching in a more vivid and interactive environment can significantly increase satisfaction with the learning environment as well as interest in the topic (Nicholson et al. 2008).

To produce quality product and be competitive on the market, companies are recognizing the importance of high talented, knowledgeable, skilful and well motivated working force. Therefore these companies are trying to create environment which will allow employees to implement their knowledge and skills and, if necessary, companies will invest further in their employees' education. One of the reasons why company has to pay attention to the education and development of employees is due to development of information technologies and their application in the company (Krsak et al. 2014).

Researching management education as a category of professional education, Bhaumik (2012) stated that it has been influenced by technology both as a driver and as an enabler. Taking into consideration that in hotel industry Property Management Systems (PMS) software are playing a vital role in overall successful management of a hotel, it is therefore understandable the need and importance of including practical use of ICTs in tourism and hotel industry into faculty courses. In the first part of the paper new ICTs used in the tourism and hospitality industry will be presented. In continuation, example of teaching both desktop and web based systems used in tourism and hotel industry will be presented and analyzed. Important implications for all interested sides in education process will be derived as well. In conclusion, the suggestions for further planning of the academic programs regarding usage of modern ICTs in the sector will be proposed.

MODERN ICTs IN TOURISM SECTOR

Usage of modern ICTs can become a facilitator in successful performance of every-day operations in hotels and also help travel agencies to struggle in the era of increasing usage of Internet in planning travel activities.

Success for some hospitality companies has been achieved, in large part, by taking advantage of information technology (Siguaw and Enz, 1999). While gathering valuable information about guests, PMSs are increasingly incorporating business intelligence tools to help hoteliers organize and make sense of these guest data. PMS

helps hotels with keeping a more comprehensive record of its reservations, guest's information and enables better coordination between different departments in the hotel, as the record of important functions in hotel is also kept in this system.

Cloud computing is the contemporary technology that is being recognized by the IT industry as the next (potential) revolution that will change how the internet and information systems operate (Sharif, 2010). Computing is being transformed to a model consisting of services that are commoditized and delivered in a manner similar to traditional utilities such as water, electricity, gas, and telephony. In such model, users access services based on their requirements without regard to where the services are hosted or how they are delivered (Buyya et al., 2009). Cloud computing is being able to deliver this utility computing vision with its specific infrastructure from which businesses and users are able to access applications from anywhere in the world on demand (Buyya et al., 2009). Thus, the computing world is rapidly transforming towards developing software for millions to consume and, in cloud computing, business applications are exposed as sophisticated services that can be accessed over a network.

In the past, company needed at least three requirements in order to install one hotel management system: software, server and data base system. With cloud based PMS there is no need for large investments in software and hardware because "Cloud Servers" are always updated to latest technology. Cloud Servers work at a very low cost (in fact no investment cost) but a reasonable monthly subscription fee is usually charged. Simplicity of the cloud based property management system allows it to be productive. Cloud based PMS can operate on any advice that has a web browser and the companies are putting their efforts to make it even more user-friendly on smaller devices like tablets and smart phones.

Importance of teaching ICTs in tourism sector

Education in tourism should be more functional and offer expertise in a particular area of tourism sector. Considering tourism is a service-oriented field constantly changing towards the needs and requirements of the clients and markets, more specialized skills are required in the area of IT, marketing, planning, promotion activities etc. This should be valid for all enterprises and businesses in tourism sector, including travel agencies and hotels. With this kind of education, as defined by Dale and Robinson (2001), Functional Tourism Degree combined with Generic Tourism Degree and Product/Market Tourism Degree should be incorporated into body of knowledge in tourism.

Important determinant of tourism development on global level is a highly efficient information technology and its use. In the research of Krsak et al. (2014), they were examining the needs for additional training for employees of organization in the field of tourism in order to improve services provided to clients by their fully trained staff. The results of the research, conducted among the providers of the services such as accommodation, catering and transport companies, information, cultural and social facilities and other tourism organizations, showed the high awareness of the need for the introduction of information technologies in tourism enterprises as a means of increasing the market share and the willingness of employees and their managers to further educate in the field.

In order to develop tourism education that will meet the needs of an expanding and differentiated global industry, there is a need for education program that will allow graduates to demonstrate good management skills and add value to organizations operating in tourism environment (Dale and Robinson, 2001). On classes of usage of ICTs in tourism and any other sector, students are able to meet with the practical terms and working conditions in the real sector. Being able to use the programs and software that are used in the real working environment means that student is able to solve some every-day operation tasks. Knowing the basics of IT sector is always recommendable as this is the fastest growing and changing sector where everything that is newly used is based on the previously learned topics.

EXAMPLE OF TEACHING MODERN ICTs IN TOURISM SECTOR

In this paper, experience of teaching both desktop and cloud versions of the management programs used in tourism and hospitality sector are examined. The research was conducted in the Tourism Faculty at Akdeniz University in Antalya. Being known as Turkish Riviera, Antalya attracts millions of tourists every year. Therefore there are hundreds of hotels and significant number of travel agencies operating in this region. According to TUROFED (Federation of Turkish Hoteliers), in 2013, 51% of 5 star hotels in Turkey are being located in Antalya. Operating in condition of great competitiveness, providing quality, fast, on time service is crucial for hotels in differentiating from the other competitors. Akdeniz University Tourism Faculty is known

for its successful cooperation with the tourism sector and as an institution that provides quality, competent and well trained students to work in the tourism sector in Antalya as well. This is partially due to the education program that includes both theoretical and practical teaching of modern ICT technologies used in tourism. After conducting interview with the teaching staff and observing the education process for a two-semester period, the research was aiming to compare teaching of desktop and cloud based PMS versions.

Following the needs of tourism and hospitality industry in Antalya, Akdeniz University Tourism Faculty has included two programs, "Agency Automation" and "Hotel Automation", in its curriculum. These programs aiming to educate students on how to use hotel and incoming travel agency automation computer programs, are being taught for one year, divided in two semesters. For the hotel automation system, students are taught the basics of using most commonly used programs in hotel industry in Turkey (FIDELIO and ELEKTRA). After the course students will be able to independently work in the program in terms of performing basic front office operations –entering both individual and group reservation, check-in and check-out operations, room management and cashier operations, create all the necessary reports, etc. It is important to mention that both English and Turkish versions of the program are being taught during the course which is very useful for students as they are able to adopt the necessary terminology in both languages and get used to changes in the working programs which may be expected to happen in the real business world. After finishing the two-semester course on incoming travel agency program, students will be able to use new age agency automation program: make basic hotel, agency, flight and similar settings inside the system, enter hotel contracts and daily tour prices, make reservations records and changes of the same in different real time situations, performing flight, rent-a-car, transfer, accounting and other operations necessary for the successful functioning of travel agencies of modern age. Both desktop and web or "cloud" versions of the travel agency program are being taught.

FINDINGS

The main characteristics of two PMS versions and, according to them, derived advantages and disadvantages of the two types of systems are presented in Table 1.

Table 1. Advantages and disadvantages of teaching desktop and web versions of the PMS

Type of system	Advantages	Disadvantages
Desktop Version	<ul style="list-style-type: none"> • Used in majority of the tourism and hospitality companies • No need for Internet connection • Every user can set the program functions and design templates according to individual needs • In case of error on one computer student can continue with the work on another one 	<ul style="list-style-type: none"> • Harder installation of the system (for every computer individually) • Students can practice only when they have access to computer classrooms • Control of the tasks given lasts longer • Extra equipment needed for server
Cloud Version	<ul style="list-style-type: none"> • Access from anywhere at any time • Giving homework and doing the same is easier • Easier control of the given tasks by teacher • Longer practicing period • More user friendly interface • No need for installation because program is always ready to use and reach from the web • No need for the additional server equipment 	<ul style="list-style-type: none"> • High Internet speed is mandatory • In case of lost of Internet connection there is no access to the system • In case connection when "server is lost" user does not have access to the system • In case of error in the system, it is present on all computers

Teaching this subject does not have only practical dimension but also theoretical one. Before going directly on the practical part of explaining the use of the management software, there is always a need to theoretically explain vocabulary and operations in the hotel or travel agency business.

IMPLICATIONS

Inclusion of modern ICTs into curriculum and teaching programs and courses will be beneficial for all interested groups in educational process: students, their future employers and educational institutions.

Students will broaden their perspective of overall business operations in tourism and hospitality sector. They will receive theoretical knowledge and gain necessary practical skills in handling property managements systems that are vital for successful performing of everyday business activities.

From the perspective of future employers, teaching modern ICTs allow them to recruit students that possess combination of generic and value-adding specialist skills. They are in constant need and search for well prepared and skilful working force, enhanced with knowledge about modern technologies and, most of all, fresh ideas. Usage of new technologies brought revolutionary and continuous changes in everyday business operations in tourism and hospitality sector. Due to this, companies in this sector became more flexible in offering their services according to needs of their customers. Therefore, they are in need of employees that are flexible and ready to handle changes in needs and requirements of the industry. Teaching and releasing university students with the knowledge about contemporary ICTs used in sector can be one positive step toward creating this kind of working force.

Universities need to encourage practitioners to participate more widely in consultative meetings on the future development of tourism education. This can be done by inviting practitioners to become members of course development committees, ask for their advice and guidance on necessary skills and emerging areas within tourism that require expertise. Through cooperation with the real business sector, universities can obtain valuable information about the trends in the sector and keep their programs up-to-date for the future benefits of all three parties. Meeting people from the industry, that are doing real job in the manner how they were taught at university, allows students to perceive their course valuable because it enriches their knowledge. Practices will be ensured for the successful students where they will have a chance to work on jobs for which they were educated. With participation of the real sector courses will be tailored according to the needs of both learners and employers.

CONCLUSION

The higher integration of ICTs with the rest of the learning environment, the higher would be its impacts (Bhaumik, 2012). Not only should web based learning systems be included in teaching and learning process in order to increase overall success of the whole course, it is necessary for the students to be taught the use of a new web-based technologies that are already in use in a real time business operations in enterprises.

If following the statements that the three interrelating factors that affect the actual use of ICTs in teaching and learning process in classroom and beyond are institutions, resources and teachers (Mumtaz, 2000), therefore the main effort should be to animate subjects involved in planning the course or provide resources necessary for the successful performing of teaching-learning activities and processes.

Career paths in tourism are so wide and open, but not all students stay in the field. This is partially due to employment possibilities in the field. Therefore the more realistic and structured employment opportunities that are able to sustain students for a career within the tourism industry should be provided. If the path is not clearly defined this can de-motivate the students and discourage them from entering into industry. Clearer career guidance needs to be given before, during and after the completion of the student's tourism degree and opportunities for practical learning of modern ICTs need to be fully integrated into their courses. Institutions should also consider opening new specialized departments or, by following the innovations in the field, update the existing teaching curriculums that will concentrate on providing more effective and practical knowledge.

In this paper the overview of the two different technologies used in real business environment in tourism and hospitality industry is provided. Although web based version of the hotel and agency management program is still not that widely used as the desktop one, the speed with which modern human society accepts and implements modern technology in every day life can allow us to predict that this situation may change in a couple of years. Therefore, tourism educational institutions should create programs that follow the trends in development of modern ICTs and include teaching of "cloud" based management systems already used in the field. In this way, educational institution will be able to act proactively and respond to challenges that tourism sector will face in the future.

REFERENCES

- Bhaumik, P.,K. (2012) Use of ICT in the Classroom Teaching of Management, *Vision*, 16. 245–252
- Buyya, R., Yeo, C.S, Venugopal, S., Broberg, J., Brandic, I. (2009). Cloud computing and emerging IT platforms: Vision, hype, and reality for delivering computing as the 5th utility, *Future Generation Computer Systems*, 25. 599-616.
- Cohen, V.L. (1997). Learning styles in a technology-rich environment. *Journal of Research on Computing in Education*, 29(4), 338–350.

- Dale, C., Robinson, N., The theming of tourism education: a three-domain approach. *International Journal of Contemporary Hospitality Management* 13/1 (2001) 30-34
- Evans, J.R. (2001). The emerging role of the internet in marketing education: From traditional teaching to technology-based education. *Marketing Education Review*, 11(3), 1–14.
- Krsak, B., Tobisova, A. & Sehnalkova, M. (2014) 5th World Conference on Educational Sciences WCES 2013 Education in Information Technology as a tool for tourism development, *Procedia – Social and Behavioral Sciences* 116, 1096-1100.
- Mumtaz, S. (2000). Factors affecting teachers' use of information and communications Technology: A review of the literature. *Journal of Information Technology for Teacher Education*, 9(3), 319–341.
- Nicholson, J., Nicholson, D., & Valacich, J.S. (2008). Examining the effects of technology attributes on learning: A contingency perspective. *Journal of Information Technology Education*, 7, 185–204.
- Siguaw, J. A., Enz, C. A., (1999). Best Practices in Information Technology. *Cornell Hotel and Restaurant Administration Quarterly* 40, (5), 58-71
- Sharif, A. M., (2010) It is written in the cloud: The hype and promise of Cloud Computing, *Journal of Enterprise Information Management*, 1-5.
- Zeng, B., Gerritsen, R. (2014) What do we know about social media in tourism? A review. *Tourism Management Perspectives* 10, 27-36

DEVELOPING AND EVALUATING PHYSICS TEACHING MATERIAL WITH ALGODOO (PHUN) IN VIRTUAL ENVIRONMENT; ARCHIMEDES' PRINCIPLE

Harun ÇELİK

Elementary Science Education, Education Faculty, Kırıkkale University, Turkey
hcelik.ef@hotmail.com

Uğur SARI

Elementary Science Education, Education Faculty, Kırıkkale University, Turkey
usari05@yahoo.com

UntungNugroho HARWANTO

Surya Institute, Indonesia
unt.nugroho@gmail.com

ABSTRACT: This study examines pre-service teachers' computer-based learning (CBL) experiences through virtual physics program, Algodoo (phun). We took one specific physics topic for the 10th grade according to the physics curriculum in Turkey. Archimedes' principle is one of the most important basic concepts needed in the study of fluid mechanics. We decided to design a simple virtual simulation in Algodoo (phun) related to Archimedes' principle. Smart board was used in order to make clear demonstration. There were 37 participants in this study who are studying pedagogical proficiency at Kırıkkale University, Faculty of Education in Turkey. Case study method was used and the data was collected by the researchers. The questionnaire consists of 28 items and 2 open-ended questions that had been developed by Akbulut, Akdeniz & Dinçer (2008). The questionnaire was used to find out the teachers' perceptions toward Algodoo for teaching physics. The result of this research recommends that using Algodoo program in physics teaching has positive impact and can improve the students' understanding.

Keywords: physics teaching, virtual environment, Algodoo, Archimedes' principle.

INTRODUCTION

The most emphasized and explored field in analysis of the physics educational research on the computer-based learning is related to the application of simulation (Şengel, Özden & Geban, 2002; Bayrak, Kanlı & İnceç 2007; Bozkurt & Sarıkoç, 2008; Jaakkola & Nurmi, 2008; Çelik, Özbek & Kartal, 2013). In the physics area, there are so many abstract concepts and principles so that it is important to generate some simulations with the kinds of computer program for the physical activities and experiment. Researchers have found that using computer simulations in instructional contexts may afford students with opportunities to promote their understanding of unobservable phenomena in science (De Jong et al., 1999; Khan, 2002; Stratford 1997).

Technology provides some of products that can be used for educational purposes. For example: smart board with related instruments can be used for teaching physics, it also parallel takes part of the continuous development for enhancing the quality of education (Geban & Demircioğlu, 1996). Technology-based teaching environment accommodates simulation so that students can use it for calculating data, sorting data, recording intended layout, testing the hypothesis, changing the variables, observing the results and visualizing the process of information. The simulation accommodates students' initiative so that they can control or operate by their own without teachers. It also provides tips and access information to the students. Increasing the students' motivation enables them to have the opportunity to learn everything by their own (Edelson, Gordin & Pea, 1999; Tao & Gunstone, 1999; Şen, 2001).

There are some prepared and used software that can be applied for simulation-assisted instruction, such as: Interactive physics, Crocodile physics, Phet and Algodoo. All of the programs have different properties and uniqueness. The specification of Algodoo is that it provides dynamic simulation using water that can't be found in other physics simulation programs. Algodoo provides fluid dynamic simulation in which gravitational acceleration automatically works. So it can be used to explain the phenomena of Archimedes' principle virtually. We decided to use and develop the physics material program with Algodoo in order to prepare an alternative physics course in virtual environment.

The new modified physics program had been prepared to improve students' scientific process skills, develop a framework of students' analytical and critical thinking skills, realize the physics concepts in their daily activity, and build a suitable correlation between science, technology, society and environment. The application of information technology, like smart board, can be used for performing a simulation or practicing an educational activity on virtual laboratory. It becomes an important issue in educational activities (MEB, 2013).

Algodoo is a unique 2D-simulation software from Algorix Simulation AB. It is designed in a playful, cartoony manner, making it a perfect tool for creating interactive scenes. Explore physics, build amazing inventions, design some cool games or experiment with Algodoo in your science classes. It encourages students and children's own creativity, ability and motivation to construct knowledge while having fun. Making it as entertaining as it is educational game. It is also a perfect aid for children to learn and practice physics at home (www.algodoo.com). As Algodoo is the number one software for creating interactive physics simulations, it is the perfect tool for learning, exploring and experimenting with real physics.

This study tried to develop a physics course program with Algodoo in virtual environment. Researchers focused on designing Archimedes' principles with Algodoo program that provides some useful simulations. This study also explored the pre-service physics teachers' perceptions towards Algodoo for teaching physics.

METHODOLOGY

Research Model

The overall research methodology was comprised of two effective assessments, including quantitative and qualitative research methods. For that reason, case study method was used in this research (Cohen & Manion, 1994). Since few contemporary physics education programs had been effectively implemented in schools in Turkey, the present study focused on pre-service teachers' learning performances to upgrade their competence via integrated simulations in physics teaching. In this research we used Algodoo program as integrated animations of physics instruments. All of the followed-up questionnaires had assessed pre-service physics teachers' performances in the Algodoo-based instruction toward Archimedes' principles. It was believed that physics instruction in Algodoo program would stimulate more interactions between students and instructors and it is suitable for the students' learning competence. We decided to choose the Algodoo program because it was so easy to operate, suitable for physics simulation and provide water simulation that are not available in other simulation programs.

Population and Sampling

Assessments of statistical samples for surveys were taken from 37 pre-service physics teachers in Kırıkkale. The participants take some pedagogical courses and practical teaching in Education Faculty of Kırıkkale University. They were enrolled in a course entitled "the Archimedes' principles with Algodoo simulation". This was a required course for pre-service physics teachers and taught by a bilingual Turkish and English instructor.

Data collection instrument and procedure

Data's gathered with quantitative and qualitative method was analyzed for this study. Quantitative data sources included a questionnaire that used semantic differentials of a likert scale. Akbulut, Akdeniz & Dinçer, (2008); Yalın, (2001); Öztekin, (2001); Uşun, (2000); Şahin & Yıldırım, (1999) had developed and used it to test teachers' perception on computer-based learning in 5 likert scale. The developed questionnaire consists of 4 major factors with 28 questions. Twenty eight questions were completed and returned by participants. The questionnaire that evaluates computer assisted teaching material was used to collect the pre-service physics teachers' perception on Algodoo-based teaching instruction. The first part which was made up of four factors, such as: instructional relevance, convenience of the program, convenience of instruction & program and formal conformity. The first factor consists of 14 questions, the second factor 4, the third factor 5 and the fourth factor 5. In the second part, two open-ended questions were conducted as qualitative data sources to find out and explore the participants' opinions about virtual physics teaching through Algodoo. The participants could write freely about their opinions toward virtual physics teaching through Algodoo. We used SPSS 17.0 to find out the statistical calculation.

Materials

In this study we developed a physics material through Algodoo in virtual environment. We decided to take one physics course in accordance with the standard curriculum of Turkey. In this point we used the 10th grade course program in accordance with the instruction of the Turkish Ministry of Education. We agreed to take the physics

topic of Archimedes' principles. The Archimedes' principle was explained to the pre-service teachers from the basic concept. We tried not to use formula in the beginning of learning. The virtual simulation through Algodoo (phun) was conducted to visualize how the Archimedes' principle works in the fluid without real experiment in laboratory (Fig. 1.). Algodoo program is appropriate to be operated for this topic. Algodoo provides dynamical simulations that help the teachers' performance when they were explaining physical phenomena to the students in the class. Algodoo program also provides a simulation of fluid dynamic so it can be applied to show the Archimedes' principle in virtual environment. Some of the tools in Algodoo can be changed automatically by the users. For example: the material's density can be changed just by controlling a bottom so that we can get any desired value of density.

Figure 1. Example of Algodoo program output

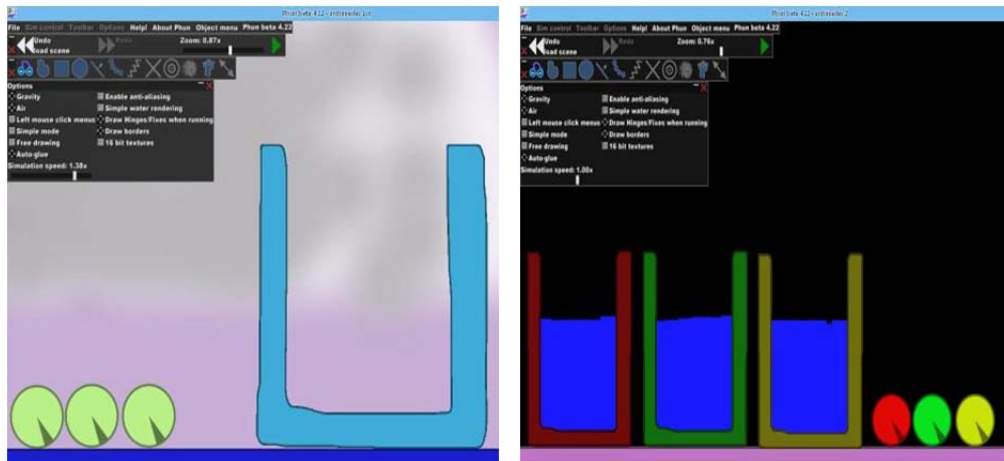

RESULTS AND FINDINGS

Table 1 showed some mean values from all factors: instructional relevance ($\bar{x} = 3.98$), convenience of program (3.59), convenience of instruction and program ($\bar{x} = 3.89$) and formal conformity ($\bar{x} = 3.89$). Each factor has mean value more than $\bar{x} = 3.43$. It indicates that Algodoo is good enough as a virtual program for teaching the Archimedes' principles. There are 3 items that have mean value more than $\bar{x} = 4.23$, show specific reason why Algodoo has high influence for teaching physics, such as: remarkable, using appropriate visualization, and encouraging creativity and developing the logical thinking.

From the qualitative analysis, researchers found some of the advantages on using Algodoo for teaching physics, such as: increasing the students' understanding toward physics (29.03%) and providing good visualization (27.42%) (Table 2.). We also found some disadvantages of using Algodoo for teaching physics, such as: problem of foreign language (26.47%), incapability to represent the overall of physical phenomena (17.65%) and preparation time (17.65%).

Table 1. Table pre-service physics teachers' perceptions about Algodoo for teaching physics

Instructional relevance		N	Mean	St. Dev.	Total $\bar{x} = 3,98$	Total SD= 0,803
Q1	Accuracy and topicality of information	37	4,00	0,707		
Q2	Compatibility of content and activities	37	4,06	0,674		
Q3	Evident and understandable instructions	37	3,73	0,902		
Q4	Feedback properties	37	3,76	0,796		
Q5	Compliance between individual and collaborative learning	37	4,00	0,745		
Q6	Content of comprehensible level	37	4,05	0,848		
Q7	Active participation and interactive accommodation	37	4,05	1,104		
Q8	Encouraging creativity and developing the logical thinking	37	4,41	0,644		
Q9	Appropriate content of partition and logical sequence of presentation	37	3,89	0,699		
Q10	Remarkable	37	4,54	0,650		
Q11	Increasing the motivation	37	3,97	0,866		
Q12	Easy to operate	37	3,65	0,949		
Q13	Understanding the content level	37	3,81	0,811		
Q14	Compatibility of students' characteristics and growth	37	3,86	0,855		
Convenience of the program						

Q15	Clear of errors	37	3,43	0,765	Total $\bar{X} = 3,59$	Total SD= 0,726
Q16	Working properly	37	3,57	0,603		
Q17	Faultless display to the students' input	37	3,58	0,692		
Q18	The speed of operation	37	3,81	0,845		
Convenience of instruction and program						
Q19	The length of working time	37	3,57	0,689	Total $\bar{X} = 3,89$	Total SD= 0,751
Q20	Compliance between the course's objectives and outcomes	37	4,03	0,763		
Q21	Providing complete subject	37	4,03	0,833		
Q22	Using flexibility and upgradeability software	37	3,84	0,688		
Q23	Constructivism activity	37	4,00	0,782		
Formal conformity						
Q24	Using color and graphic	37	4,16	0,727	Total $\bar{X} = 4,06$	Total SD= 0,835
Q25	Using appropriate visualization	37	4,24	0,723		
Q26	Display intensity	37	3,92	0,924		
Q27	Available to read the display	37	3,81	0,938		
Q28	Using the screen space	37	4,16	0,866		

Table 2. Table pre-service physics teachers' opinion about Algodoo for teaching physics

Advantages		Frequency	Percentage
1.	Increasing the students' understanding toward physics	18	29,03
2.	Providing good visualization	17	27,42
3.	Easy to operate	7	11,29
4.	Enhance the students' creativity	5	8,06
5.	Making physics easier	5	8,06
6.	Represent the physical phenomena in visual program	5	8,06
7.	Entertaining	3	4,84
8.	Good for fluid simulation	2	3,23
Disadvantages			
1.	Problem with foreign language	9	26,47
2.	Can't represent the overall of physical phenomena	6	17,65
3.	Preparation time	6	17,65
4.	Lack of properties and tools	5	14,71
5.	The water density can't be changed	4	11,76
6.	Unavailable for mathematical calculation	2	5,88
7.	Lack of computer literacy	1	2,94
8.	Operating program	1	2,94

CONCLUSION

Findings indicated that most pre-service teachers were highly interested in using the Algodoo for teaching physics. According to the participants, the integration of data acquisition experiments with closely associated computer simulations has proved to be particularly effective in the learning process (Kocijancic & Q'sullivan, 2004). In this study, deemed appropriate and supporting meaningful learning of the simulation program is remarkable. So, we believe that there is considerable additional pedagogical advantage to be gained by the integration of the various CBL tools and concepts available, particularly by integrating "teaching curriculum" and "virtual" laboratory activities (Podolefsky, Perkins & Adams, 2010; Tatlı & Ayas, 2010; Sari & Güven, 2013).

RECOMMENDATION

The computer program can be used to enhance the students' motivation toward physics (Şen, 2001). Computer program sometimes provides an alternative solution for solving unobserved phenomena. Algodoo is one program that can be operated in various physical phenomena. It provides fluid simulation so it can be utilized for explaining the Archimedes' principle to the students. By giving attractively demonstration and virtual visualization, it can increase the students' motivation and gain a better understanding toward physics. To gain a better educational service, the teachers and students should improve their English language skills because almost the computer program is operated in English instructional language. And Algodoo should develop their program in order to provide a better and more complete physical simulation.

REFERENCES

Akbulut, Ö. E., Akdeniz, A. R. & Dinçer, G. T. (2008). Bilgisayar destekli bir öğretim materyalinin tasarlanması ve değerlendirilmesi. 8. Uluslararası Eğitim Teknolojileri Konferansı, 974-978, Eskişehir: Anadolu Üniversitesi.

- Bayrak, B., Kanlı, U. & İnceç, Ş.K. (2007). To Compare the Effects of Computer-Based Learning and the Laboratory-Based Learning on Students' Achievement Regarding Electric Circuits. *The Turkish Online Journal of Educational Technology*.
- Bozkurt, E. & Sarıkoç, A. (2008). Fizik Eğitiminde Sanal Laboratuvar, Geleneksel Laboratuvarın Yerini Tutabilir mi?. *Selçuk Üniversitesi Ahmet Keleşoğlu Eğitim Fakültesi Dergisi*, 25: 89-100.
- Cohen, L. & Manion, L. (1994). Research methods in education. (Fourth Edition), Newyork: Rutledge.
- Çelik, H., Özbek, G., & Kartal, T. (2013). The Effect Of Computer-Aided 7E Instruction Model On Students' Scientific Process Skills. *Mediterranean Journal of Educational Research*, Issue 14a, pp. 926-932.
- De Jong, T., Martin, E., Zamarro, J. M., Esquembre, F., Swaak, J., & van Joolingen,. (1999). The integration of computer simulation and learning support: An example from the physics domain of collision. *Journal of Research in Science Teaching*, 36(5), 597-615.
- Edelson, D.C.,Gordin, D.N. & Pea, R.D. (1999). Addressing the Challenges of Inquiry-Based Learning Through Technology and Curriculum Design. *Journal of the Learning Sciences*, 8: 391-450.
- Geban, Ö. & Demircioğlu, H. (1996). Fen Bilgisi Öğretiminde Bilgisayar Destekli Öğretim ve Geleneksel Problem Çözme Etkinliklerinin Ders Başarısı Bakımından Karşılaştırılması. *Hacettepe Üniversitesi Eğitim Fakültesi Dergisi*. 12: 183-185.
- Jaakkola, T., & Nurmi, S. (2008). Fostering elementary school students' understanding of simple electricity by combining simulation and laboratory activities. *Journal of ComputerAssisted Learning*, 24(4), 271-283.
- Khan, S. (2002). *Teaching chemistry using guided discovery and an interactive computer tool*. Unpublished doctoral dissertation (pp. 1-337). Amherst: University of Massachusetts.
- Kocijancic, S. & Q'sullivan, C. (2004). Real or Virtual Laboratories in Science Teaching –is this Actually a Dilemma? *Informatics in Education*, Vol. 3, No. 2, 239-250
- MEB. (2013). Fizik öğretim programı, Talim ve Terbiye Kurulu Başkanlığı. Ankara
- Öztekin, B. (2001). *Excel Yardımıyla Birinci ve İkinci Dereceden Fonksiyonlar Konusunun Öğretimi Tasarım, Uygulama, Değerlendirme*. Yayınlanmamış Yüksek Lisans Tezi. Karadeniz Teknik Üniversitesi, Trabzon.
- Podolefsky, N.S.,Perkins, K.K., & Adams, W.K. (2010). Factor spromoting engaged exploration with computer simulations. *Physical review special topics – physics education research*,6, 020117.
- Sarı, U. & Güven, G.B. (2013). Etkileşimli Tahta Destekli Sorgulamaya Dayalı Fizik Öğretiminin Başarı ve Motivasyona Etkisi ve Öğretmen Adaylarının Öğretime Yönelik Görüşleri, *Necatibey Eğitim Fakültesi Elektronik Fen ve Matematik Eğitimi Dergisi (EFMED)* Cilt 7, Sayı 2, sayfa 110-143.
- Stratford, S. (1997). A review of computer-based model research in precollege science classroom. *Journal of Computers in Mathematics and Science Teaching*, 16(1), 3-23.
- Şahin, T. Y. & Yıldırım, S. (1999). *Öğretim Teknolojileri ve Materyal Geliştirme*. Ankara: Anı Yayıncılık.
- Şen, A. İ. (2001). Fizik Öğretiminde Bilgisayar Destekli Yeni Yaklaşımlar. *G.Ü. Gazi Eğitim Fakültesi Dergisi*, 21 (3): 61-71.
- Şengel, E., Özden, M. Y. & Geban, Ö. (2002). Bilgisayar Simulasyonlu Deneyle Lise Öğrencilerinin Yerdeğiştirme ve Hız Kavramlarını Anlamadaki Etkisi. V. *Ulusal Fen Bilimleri ve Matematik Eğitimi Kongresi*, 2, 1424-1429.
- Tao, P. K. & Gunstone, R. F. (1999).The Process of Conceptual Change in Force and Motion during Computer-Supported Physics Instruction. *Journal of Research in Science Teaching*, 36(7), 859-882.
- Tatlı, Z. & Ayas, A. (2010). Virtual laboratory applications in chemistry education. *Procedia Social and Behavioral Sciences*, 9, 938-942.
- Uşun, S. (2000). *Dünyada ve Türkiye'de Bilgisayar Destekli Eğitim*. Ankara: Pegem A Yayıncılık.
- Yalın, H. İ. (2001). *Öğretim Teknolojileri ve Materyal Geliştirme* (5.baskı). Ankara: Nobel Yayın Dağıtım.

AKADEMİSYENLERİN TABLET PC KULLANIMI HAKKINDAKİ GÖRÜŞLERİ: SÜLEYMAN DEMİREL ÜNİVERSİTESİ ÖRNEĞİ

ACADEMICIANS' OPINIONS ON USING TABLET PC: SULEYMAN DEMIREL UNIVERSITY CASE

Abdullah ÖZKALE
Süleyman Demirel Üniversitesi
abdullahozkale@sdu.edu.tr

Mustafa KOÇ
Süleyman Demirel Üniversitesi
mustafakoc@sdu.edu.tr

ÖZET: Teknolojik gelişmelerin hızına yetişmenin oldukça zor olduğu bir dönemde teknolojinin kişiler tarafından nasıl algılandığı ve kullanıldığını araştırmak oldukça zor ve bir o kadarda önemli bir süreçtir. Kullanıcıların akademisyen ya da eğitimci olması bu durumun başka bireyleri de etkileyeceği anlamına gelmektedir. Bu çalışma; Türkiye’de araştırma sayısı oldukça az olan tablet bilgisayarların akademik çevrede nasıl benimsendiği ve kullanıldığı; bunun yanında algıları nasıl yönlendirdiğini ortaya koymayı amaçlamaktadır. Çalışmanın teorik çerçevesini Teknoloji Kabul Modeli (TKM) ve İnsan Bilgisayar Etkileşimi (İBE) oluşturmaktadır. Katılımcılar amaçlı ve kartopu örnekleme yöntemleriyle seçilmiştir. Veriler Süleyman Demirel Üniversitesi’ndeki Tablet PC kullanıcısı bir grup akademisyenden yarı yapılandırılmış görüşme yoluyla toplanmış ve içerik analizine tabi tutulmuştur. Bu görüşmeler genel olarak akademisyenlerin Tablet PC kullanımına yönelik tutum, görüş, beklenti ve tecrübelerini ve diğer PC çeşitleri ile kıyaslamalarını içermektedir. İçerik analizi sonucunda bulgular; Tablet PC alma gerekçeleri, kullanım desenleri (sıklık, ortam, deneyim, amaç), kullanımında karşılaşılan kolaylıklar ve zorluklar, mesleki ve öğretimsel kullanımı, kullanımından doğan performans artışı, kullanımı üzerine düşünceler (verimlilik, memnuniyet, ilk tercih, diğer PC’lere ihtiyaçta azalma), diğer PC çeşitleri ile kıyaslanması, Tablet PC’ye yönelik beklentiler temaları altında düzenlenmiştir.

Anahtar sözcükler: Tablet PC, Akademisyenler, Görüşler, Deneyimler

ABSTRACT: It is a difficult and important process to explore how people perceive, adopt and use technology especially in the era of rapid and constant technological developments. When it comes to academicians or educators as being the users of technology, such process also impacts other users such as students. This qualitative study aimed to reveal how Tablet PCs are being adopted and used and how they shape perceptions in academic environments within the context of higher education. The theoretical framework of the study was grounded on Technology Acceptance Model (TAM) and Human Computer Interaction (HCI). Participants were selected through purposeful and snowball sampling strategies from the academicians working at the Suleyman Demirel University in Isparta, Turkey. The main characteristic that made an academician eligible for participation in the study was being a Tablet PC user. Data were collected from 15 academicians through in-depth semi-structural interviews and analyzed by means of content analysis technique. The interviews generally contain academicians’ lived experiences, opinions, attitudes, and expectations germane to Tablet PC use as well as their comparisons’ of Tablet PC to other PCs including desktop and laptop computers. The findings were organized under these themes: reason for buying Tablet PC, usage patterns (frequency, context, experience, and purpose), ease and difficulty of use, professional and instructional use, perceived performance increase due to its use, opinions and expectations from Tablet PCs, and comparison of Tablet PC to other PCs.

Key words: Tablet PC, Academicians, Opinions, Lived experiences

VERİ MADENCİLİĞİ TEKNİKLERİ KULLANILARAK ORTAOKUL ÖĞRENCİLERİNİN MATEMATİK ÖĞRENME STILLERİ İLE MATEMATİK DERSİNE YÖNELİK TUTUMLARININ VE ARALARINDAKİ İLİŞKİLERİN İNCELENMESİ

USING DATA MINING TECHNIQUES TO EXAMINE THE RELATIONSHIP BETWEEN MIDDLE SCHOOL STUDENTS' MATHEMATIC LEARNING STYLES AND THEIR ATTITUDES TOWARDS MATH LESSON

Feriha Hande ÇIKRIKÇI
Dokuz Eylül Üniversitesi

Serkan NARLI
Dokuz Eylül Üniversitesi

Esra AKSOY
Dokuz Eylül Üniversitesi

ÖZET: Bu araştırmada, ortaokul öğrencilerinin matematik öğrenme stilleri ile matematik dersine yönelik tutumları arasındaki ilişkinin veri madenciliği ile belirlenmesi amaçlanmıştır. Araştırmanın kapsamında İzmir, Aydın ve Manisa illerinde öğrenim gören 702 ortaokul öğrencisinin matematik öğrenme stillerini belirlemek amacıyla “Matematik Sınıfta Nasıl Öğrenilir?” ölçeği ve matematik dersine yönelik tutumlarını ölçmek amacıyla tutum ölçeği uygulanmıştır. Veri madenciliği yöntemlerinden karar ağaçları ve birliktelik kuralları kullanılmıştır. Ayrıca ağ grafiği kullanılarak değişkenler arasındaki ilişki görselleştirilmiştir. Oluşturulan C5.0 karar ağacında öğrenme stillerini belirlemede en önemli değişkenin matematik dersine yönelik tutum olduğu görülmüştür. Birliktelik Kurallarından Apriori uygulanarak %76 güvenirlilik ile anne ve baba eğitim düzeyleri ortaokul olan kız öğrencilerin açıklayıcı öğrenme stiline sahip oldukları gözlenmiştir. Matematik dersine yönelik tutum ile matematik öğrenme stilleri arasındaki ağ grafiği incelendiğinde ise en kuvvetli ilişkinin açıklayıcı öğrenme stili ile matematik dersine yönelik çok yüksek düzeyde tutuma sahip öğrenciler arasında olduğu görülmektedir.

Anahtar sözcükler: Matematik öğrenme stilleri, matematik dersine yönelik tutum, eğitimsel veri madenciliği

ABSTRACT: The aim of this study is examining the relationship between middle school students' mathematic learning styles and their attitudes towards mathematic lesson with data mining. ‘How do I actually learn?’ inventory and attitude scale was applied to 702 middle school students studying in İzmir, Aydın and Manisa. Data mining techniques such as decision tree and association rules were implemented. Furthermore web graph was used for visualisation of relationship between mathematic learning styles and attitude towards mathematic lesson. Constructed decision tree models with C5.0 algorithm revealed that attitude towards mathematic lesson was the most important attribute to identify learning style. Using association rules, several rules are constructed with %76 confidence. In network graph, it was found that the strongest relationship was between **açıklayıcı** learning style and very high level attitude towards mathematic lesson.

Key words: Mathematic learning styles, attitude towards mathematic lesson, educational data mining

GİRİŞ

Öğrenme süreci tüm bireyler için aynı değildir. Öğrenmeyi yönlendiren fiziksel yollar her birey için değişebilen süreçlerin oluşmasına yol açmaktadır. Her öğrenci öğrenirken ya da hatırlamaya çalışırken kendine ait bir yol izler, öğrenme esnasında takip ettiği bu yola öğrenme stili denir. Bilgiyi alma ve işleme sürecinde her öğrenci, farklı yollar kullandığı için, farklı öğrenme stillerine sahip olur. Örneğin, bir kısım öğrenciler, olaylar ve simgelere yoğunlaşırken, bazıları da kuramlar ve matematiksel modellerde daha rahatlar. Öğrencilerin bazıları resimler, diyagramlar, şemalar gibi görsel uyaranlara daha güçlü tepki gösterirken, diğerleri daha çok yazılı ve sözlü açıklamaları içeren sözel formları tercih eder. Bazı öğrenciler, aktif ve etkileşimli bir şekilde öğrenmeyi tercih ederken, bazıları daha kişisel ve kendi duygularını ışığında öğrenmeyi tercih eder (Felder, 1996) Farklı

dersler açısından öğrencilerin öğrenme stilleri hakkında bilgi sahibi olmak öğrencilere öğretim esnasında nasıl yaklaşılacağı açısından önemlidir. Bu çalışmadan da anlaşılacağı gibi matematiği öğrenirken bireyler farklı öğrenme stillerinden yararlanırlar. Bu çalışmada veri toplama aracı olarak kullanılan “Matematik Sınıfta Nasıl Öğrenilir?” ölçeğinde dört farklı öğrenme stili ile ilgili sorular bulunmaktadır. Bu öğrenme stilleri şunlardır: Açıklayıcı öğrenme, sorgulayıcı öğrenme, çabalayıcı öğrenme ve kullanımcı öğrenme.

- **Açıklayıcı öğrenme:** Bu öğrenme stiline sahip bireyler matematiği en iyi; sınıf çalışmalarında sorulara yanıt vererek, arkadaşlarının sorularına yanıt vererek ve arkadaşlarına konuyu anlatarak öğrenirler.
- **Sorgulayıcı öğrenme:** Bu öğrenme stiline sahip bireyler matematiği en iyi; öğretmene kendi düşüncelerine aynen katılıp katılmadığını sorarak, konuların birebir açıklamasını öğretmenden isteyerek, arkadaşlarına düşüncelerine katılıp katılmadığını sorarak ve arkadaşlarından konuların açıklanmasını isteyerek öğrenirler.
- **Çabalayıcı öğrenme:** Bu öğrenme stiline sahip bireyler matematiği en iyi; problemleri derste çözerek, problemleri diğer öğrencilerle çözerek, kendi başına çalışarak ve çözümleri yazarak öğrenirler.
- **Kullanımcı öğrenme:** Bu öğrenme stiline sahip bireyler matematiği en iyi; hesap makinesi (bilgisayar vb.) kullanarak, işlemleri hesap makinesinde/bilgisayarda deneyerek ve bütün sınıf çalışmaları boyunca öğretmeni dinleyerek öğrenirler.

Bireylerin kendi öğrenme stillerinin farkında olarak öğrenme-öğretme sürecinde bulunmalarının sağlanması ve akademik başarı, özgüven gibi özelliklerinin geliştirilebilmesi için, küçük yaşlardan başlayarak öğrenme stili özelliklerinin belirlenmesi gerekmektedir. Öğrencilerin bir dersten başarılı olmalarını etkileyen faktörlerden bir diğeri ise öğrencilerin iyi çalışma, tutum ve alışkanlıklarına sahip olmalarıdır (Küçükahmet, 2000). Belirli nesne, durum, kurum, kavram ya da diğer insanlara karşı öğrenilmiş, olumlu ya da olumsuz tepkide bulunma eğilimi (Tezbaşaran, 1996) olarak tanımlanan tutumlar öğrenme süreci sırasında ortaya çıkan duygularla başa çıkma ve kontrol altına alma ile ilgili olup, insan davranışlarına yön vermede önemli bir role sahiptir. Bir değer ve inanç sistemine bağlı olarak oluşan tutumların olumlu ya da olumsuz olması öğrenme sürecini doğrudan etkilemekte ve bireylerin gelecekteki yaşantılarına yön vermektedir (Seferoğlu, 2004; Sünbül ve diğerleri, 2004). İlköğretim basamağından başlayarak gerçekleştirilecek öğrenme stillerini belirleme çalışmaları ile öğrencilerin derslerde daha başarılı olmaları sağlanırken, kimi derslerde öğrenmeye ilişkin olumsuz yaşantılarla karşılaşmalarının önüne geçilebilir.

Araştırmada, ortaokul öğrencilerinin matematik öğrenme stilleri ile matematik dersine yönelik tutumları arasındaki ilişkinin veri madenciliği teknikleri kullanılarak belirlenmesi amaçlanmıştır. Veri madenciliği, veriyi farklı açılardan analiz etmeyi ve bu veriyi kullanışlı bilgiye dönüştürerek özetlemeyi sağlayan veri analizi metodudur. Eğitimsel veri madenciliği ise eğitimsel veri tabanlarından elde edilen veriye, eğitimsel amaçlar doğrultusunda veri madenciliği yöntemlerinin uygulanmasıyla ortaya çıkan bir araştırma alanıdır.

Uygulamaya yönelik bakış açısı ile bakıldığında eğitimsel veri madenciliği, örneğin, eğitimsel sistemleri değerlendirmeye yardımcı olmak için öğrencilerin kullanılabilir verilerine dayalı yeni bilgiler keşfetmeye ve eğitim kalitesini bazı yönlerden potansiyel olarak geliştirmeye ve daha etkili bir öğrenme süreci için altyapı hazırlamaya izin verir. (Romero, Ventura&Bra, 2004).

Ortaokul öğrencilerinin matematik öğrenme stilleri ile matematik dersine yönelik tutumları arasındaki ilişkinin veri madenciliği ile belirlenmesi kapsamında aşağıdaki problem ve alt problemlere yanıt aranmıştır:

Problem cümlesi: Veri madenciliği ile incelendiğinde, ortaokul öğrencilerinin matematik öğrenme stili ile matematik dersine yönelik tutumları arasındaki ilişkiler nasıldır?

Alt problemler:

1. Ortaokul öğrencilerinin matematik öğrenme stillerinin dağılımı nasıldır?
2. Ortaokul öğrencilerinin matematik dersine yönelik tutum düzeyleri nelerdir?
3. Ortaokul öğrencilerinin matematik öğrenme stili ile matematik dersine yönelik tutum düzeyleri arasındaki ilişkiler, veri madenciliğinin karar ağaçları ve birliktelik kuralları yöntemleri ile incelendiğinde nasıl belirlenmekte ve ağ grafiği ile gösterimi nasıl olmaktadır?

YÖNTEM

Araştırmanın modeli

Araştırma betimsel nitelikte olup, ortaokul öğrencilerinin buldukları matematik öğrenme stili boyutunun matematik dersine yönelik tutumlarının ve bunların bazı değişkenlerle ilişkisinin belirlenmesi amacıyla yapılan

Survey (Tarama) Modeli'nin bir alt yöntemi olan ilişkisel tarama kullanılmıştır. İlişkisel tarama yöntemi, en az iki durum ya da değişken üzerindeki korelasyonu ortaya koymada kullanılan araştırma modelidir. (Karasar,1998)

Evren ve örneklem

Araştırmanın evrenini 2013-2014 eğitim öğretim yılında Aydın ili Köşk ilçesinde bulunan ortaokullarda öğrenim gören 5.,6.,7. ve 8. sınıf öğrencileri, örneklemini ise random yoluyla belirlenen dört ortaokulda öğrenim gören 702 ortaokul öğrencisi oluşturmuştur.

Veri toplama araçları

Çalışmada, verilerin toplanması aşamasında öğrencilerin öğrenme stillerini belirlemek için, Forster (1999) tarafından geliştirilen, dört öğrenme stilini temsil eden toplam 22 maddeden oluşan 5'li likert tipi "Matematik Sınıfta Nasıl Öğrenilir ?" ölçeğinden yararlanılmıştır. Öğrencilerin matematik dersine yönelik tutumlarını ölçmek için ise geçerliliği ve güvenilirliği yapılmış Aşkar (1986) tarafından geliştirilen 5'li likert tipi tutum ölçeği kullanılmıştır. Araştırmaya katılan öğrencilerin demografik özelliklerini belirlemek amacıyla ölçeğin üst kısmına bir bölüm eklenmiş ve bu bölümdeki sorular yardımıyla öğrencilerin cinsiyet, sınıf düzeyi, okul öncesi eğitimi alıp almama, anne ve baba eğitim düzeyleri gibi özelliklerine ulaşılmıştır.

Veri çözümleme teknikleri

Elde edilen veriler SPSS paket programı ve SPSS Clementine programları ile analiz edilecektir. Clementine veri madenciliği uygulamaları için SPSS tarafından geliştirilmiş görsel modelleme aracıdır. Clementine farklı veri kaynaklarına ulaşma olanak sağlayan, modelleri hızlı bir şekilde oluşturma ve karşılaştırma olanaklarıyla ön plana çıkan yazılımdır (Aydın, 2007).

BULGULAR

Ortaokul öğrencilerinin matematik öğrenme stilleri ve matematik dersine yönelik tutumlarının farklı bağımsız değişkenler de dahil edilerek incelenmesinden elde edilen bulgulara yer verilmiştir. Bu değişkenler cinsiyet, sınıf seviyesi, okul öncesi eğitimi alma durumu, anne ve baba eğitim düzeyleridir. Alt problemlere yönelik araştırma bulguları aşağıda verilmiştir:

1. Alt probleme ilişkin bulgular

Ortaokul öğrencilerinin matematiksel öğrenme stilleri dağılımı incelendiğinde öğrencilerin en çok açıklayıcı öğrenme stiline (41,6%), en az ise kullanımcı öğrenme stiline (6,4 %) sahip oldukları görülmektedir.(Tablo 1)

Tablo 1 Ortaokul Öğrencilerin Matematiksel Öğrenme Stili Dağılımları

	Matematiksel Öğrenme Stili					Toplam
	Çift Stil	Açıklayıcı	Kullanımcı	Çabalayıcı	Sorgulayıcı	
Öğrenci Sayısı	84	292	45	46	235	702
Öğrenci Yüzdeleri	12,0%	41,6%	6,4%	6,6%	33,5%	100%

2. Alt Probleme İlişkin Bulgular

Ortaokul öğrencilerinin matematik dersine yönelik tutum dağılımı incelendiğinde öğrencilerin en çok çok yüksek tutuma (39,3%), en az ise çok düşük tutuma (1,1 %) sahip oldukları görülmektedir.(Tablo 2)

Tablo 2 Ortaokul Öğrencilerin Matematik Derine yönelik Tutum Dağılımları

	Matematik Dersine Yönelik Tutum					Toplam
	Çok Düşük Tutum	Düşük Tutum	Orta Tutum	Yüksek Tutum	Çok Yüksek Tutum	
Öğrenci Sayısı	8	45	153	220	276	702
Öğrenci Yüzdeleri	1,1%	6,4%	21,8%	31,3%	39,3%	100%

3. Alt probleme ilişkin bulgular

Ortaokul öğrencilerinin matematik öğrenme stilleri ile matematik dersine yönelik tutumları arasındaki ilişkinin incelenmesinde veri madenciliği tekniklerinden karar ağaçları ve birliktelik kuralları kullanılmıştır. Ayrıca web ağı kullanılarak aralarındaki ilişki görselleştirilmiştir.

Karar ağacı

Karar ağacı ağaç yapısına benzer bir akış şemasıdır. Bu şemada her bir düğüm bir bağımsız değişken üzerinde testi, her bir dal test sonucunu ve ağacın yaprakları ise sınıfları gösterir (Garg & Sharma, 2013). Karar ağacı oluşturulurken veri tekrarlı bir biçimde daha küçük alt kümelere bölünür. Her bir bölmede en uygun bağımsız değişkenin seçimi önemli bir konudur. Burada bağımlı değişkene göre en homojen alt kümeyi oluşturan bölme seçilmiş olmalıdır. Bölme süreci daha uygun bir bölme kalmayana kadar devam eder (Güntürkün, 2007).

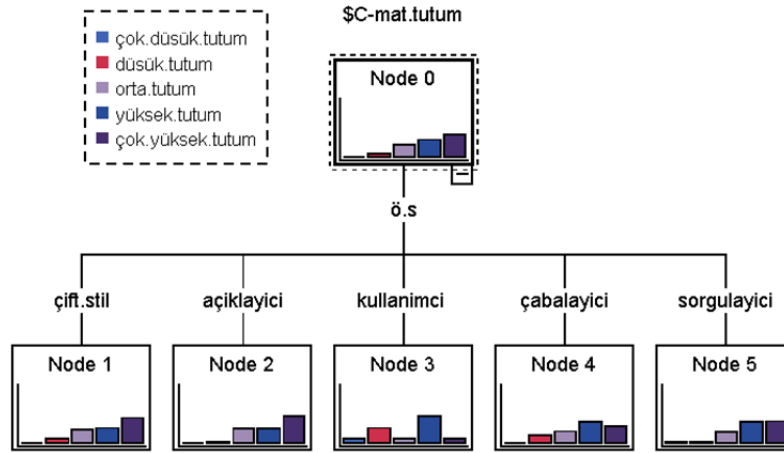

Şekil 1 Matematik Dersine Yönelik Tutum Ve Matematik Öğrenme Stili C5.0 Karar Ağacı

Matematik dersine yönelik tutum bağımlı değişken ve matematik öğrenme stili bağımsız değişken kabul edilerek oluşturulan C5.0 karar ağacında son düğümdeki frekanslar grafiksel olarak gösterildiğinde matematiksel tutumun öğrenme stiline göre farklılaştığı, açıklayıcı ve çift öğrenme stiline sahip öğrencilerin matematik dersine yönelik tutumunun çok yüksek düzeyde olduğu görülmektedir.(Şekil 1)

Cinsiyet, sınıf seviyesi, okul öncesi eğitim alma durumu, anne-baba eğitim düzeyi ve matematik dersine yönelik tutum değişkenleri kullanılarak matematik öğrenme stiline belirlenmesi için oluşturulan C5.0 karar ağacında ise en etkili değişkeni gösteren ilk dallanmanın matematik dersine yönelik tutum olduğu; matematik dersine yönelik tutumun belirlenmesinde ise en etkili değişkenin sınıf seviyesi olduğu belirlenmiştir.

Ağ grafiği

Ağ grafiği, değişkenler arasındaki ilişkinin gücünü gösteren grafik türüdür. İki değişken arasındaki çizginin kalınlığı o iki değişken arasındaki ilişkinin kuvvetini gösterir. Şekil 2'de matematik öğrenme stilleri ile matematik dersine yönelik tutum düzeyleri arasında oluşturulan ağ grafiği incelendiğinde en kuvvetli ilişkinin açıklayıcı öğrenme stili ve çok yüksek düzeyde matematik dersine yönelik tutuma sahip öğrenciler arasında olduğu görülmektedir. Ağ grafiğinde duyarlılığın azaltılması ile sadece ilişki gücü yüksek olan değişkenler arasındaki ilişkiyi görmek mümkün olmaktadır.

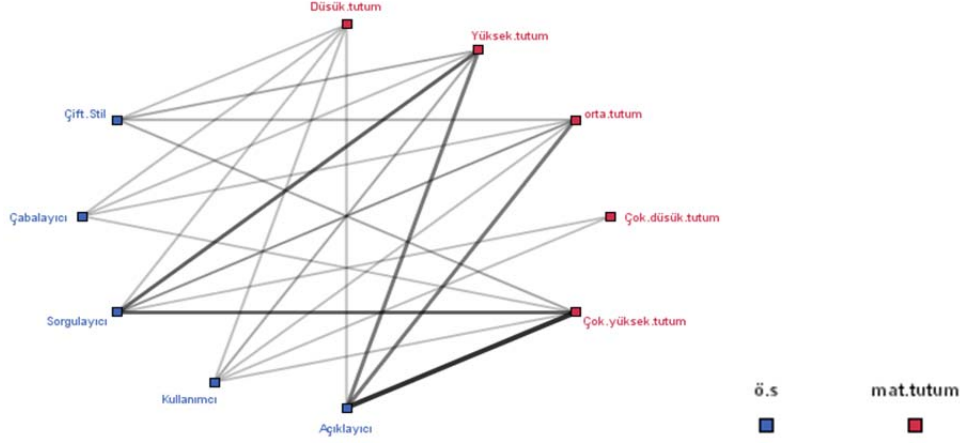

Şekil 2 Matematik Öğrenme Stilleri ve Matematik Dersine Yönelik Tutum Düzeyleri Arasındaki İlişki Ağ Grafiği

Birliktelik kuralları

Birliktelik kuralları verideki güçlü birliktelik özelliklerini tanımlayan örüntüleri keşfetmek için kullanılan bir analiz yöntemidir. Keşfedilmiş örüntüler özel olarak çıkarılan kurallar veya özellik alt grupları şeklinde temsil edilebilir (Aydın, 2007). Sol kısım öncül veya koşul olarak adlandırılırken sağ kısımda bağlı koşul olarak adlandırılır. Buradaki genel form IF-THEN ilişkisi ile ifade edilmektedir. IF<önkoşul> THEN<bağlı koşul> şeklinde gösterilebilir. Birliktelik kuralında değişkenler arasındaki bağıntı destek ve güven kriteri ile hesaplanmaktadır. Destek kriteri, veride öğeler arasındaki ilişkinin ne kadar sık olduğunu, güven kriteri ise A öğesinin hangi olasılıkla B öğesi ile beraber olduğunu ifade etmektedir. İki öğenin birlikteliğinin önemli olması için hem destek hem de güven kriterinin yüksek olması gerekmektedir (Han & Kamber, 2006). Birliktelik kurallarında 1'in üzerindeki lift değeri ise değişkenler arasında kuvvetli ilişkileri gösterir (Pandey & Pal, 2011). Bu çalışma kapsamında birliktelik kuralları için apriori algoritması kullanılmıştır.

Consequent	Antecedent	Support %	Confidence...	Lift
ö.s = açıklayıcı	sinif = 8,00 mat.tutum = çok.yüksek.tutum cinsiyet = erkek babaegitimdüzeyi = ilkokul anneegitimdüzeyi = ilkokul	5.413	76.316	1.835

Şekil 3 Matematiksel Öğrenme Stili, Matematiksel Tutum ve demografik Değişkenler Arasında Birliktelik Kuralları

Sınıf seviyesi, cinsiyet, anne baba eğitim düzeyi, okul öncesi eğitim alma durumu gibi demografik değişkenleri ile matematik tutumunun ön koşul ve matematik öğrenme stili değişkeninin bağlı koşul olarak alındığı en az %75 güvenilirlik seviyesindeki birliktelik kuralları analizi sonuçlarına göre çok yüksek seviyede matematiksel tutuma sahip ve anne-baba eğitim düzeyi ilkokul olan 8. Sınıf erkek öğrencilerin yaklaşık olarak %76 'sının matematiksel öğrenme stiline açıklayıcı olduğu ve bu öğrencilerin örneklem grubumuzun yaklaşık olarak %5,4'üne karşılık geldiği, görülmektedir. (Şekil 3)

SONUÇ ve ÖNERİLER

Araştırmada ortaokul öğrencilerinin matematik öğrenme stilleri ile matematik dersine yönelik tutumlarının veri madenciliği ile incelenmesi amaçlanmıştır. Bu amaç doğrultusunda öncelikle öğrencilerin matematik öğrenme stilleri ve matematik dersine yönelik tutum düzeyleri dağılımı incelenmiştir. Buna göre ortaokul öğrencilerinin matematik öğrenme stillerinden en çok açıklayıcı, en az ise kullanımcı öğrenme stilini tercih ettikleri görülmüştür. Bu durum öğrencilerin çoğunun bütün sınıf çalışmaları boyunca öğretmeni dinlemek yerine sorulara yanıt vererek ve arkadaşlarına anlatarak öğrenmeyi tercih ettiği şeklinde yorumlanabilir. Ortaokul öğrencilerinin matematik dersine yönelik tutum düzeylerinden ise 'çok yüksek tutum' frekansının en yüksek olduğu bulunmuştur. Bu sonuç ilköğretim 4, 5, 6, 7 ve 8.sınıf öğrencilerinin matematik dersine yönelik tutum puanlarının düşük olduğu yönünde bulgulara rastlayan Akın (2002)'nin sonuçları ile farklılık göstermektedir.

Matematiksel öğrenme stiline bağlı olarak matematik dersine yönelik tutum için oluşturulan karar ağacı matematiksel tutumun öğrenme stiline göre farklılaştığı, açıklayıcı ve çift öğrenme stiline sahip öğrencilerin matematik dersine yönelik tutumunun çok yüksek düzeyde olduğu görülmektedir. Ağ grafiği bu sonucu desteklemekte ve en kuvvetli ilişkiyi gösteren en kalın çizginin açıklayıcı öğrenme stili ile çok yüksek tutum düzeyi olduğu görülmektedir. Sonuç olarak arkadaşlarına konuyu anlatarak ve sorulara yanıt vererek öğrenmeyi tercih eden öğrencilerin matematik dersine yönelik tutum düzeylerin arttığı yorumu yapılabilir. Matematik dersine yönelik tutumun öğrenme stillerine göre değişiklik göstermesi Albayrak(2008)'in farklı öğrenme stiline sahip öğrencilerin en az iki grubunun matematiğe karşı tutum puanı ortalamaları arasında anlamlı fark bulduğu çalışması ile örtüşmektedir.

Ortaokul öğrencilerinin bazı demografik özellikleri ve matematik dersine yönelik tutum değişkenleri kullanılarak matematik öğrenme stiline belirlenmesi için karar ağacı oluşturulduğunda ise en etkili değişkeni gösteren ilk dallanmanın matematik dersine yönelik tutum olduğu; matematik dersine yönelik tutumun belirlenmesinde ise en etkili değişkenin sınıf seviyesi olduğu belirlenmiştir. Öğrencilerin sınıf düzeyi ilerledikçe ve matematiğe ilişkin yaşantıları arttıkça matematiğe yönelik tutumda düşme olduğunu tespit eden diğer araştırmacıların (Baykul, 1990; Hannula, 2002; Taşdemir, 2009) bulgularıyla örtüşmektedir.

Öğrenme stilleri ile tutum ve demografik değişkenler arasındaki birliktelik kuralları analizi sonuçlarına göre çok yüksek seviyede matematik dersine yönelik tutuma sahip ve anne-baba eğitim düzeyi ilkökul olan 8. Sınıf erkek öğrencilerin yaklaşık olarak %76 'sının matematiksel öğrenme stiline açıklayıcı olduğu ve bu öğrencilerin örneklem grubumuzun yaklaşık olarak %5,4'üne karşılık geldiği, görülmektedir.

Sonuç olarak, öğrencilerin farklı öğrenme stillerine sahip olabildikleri görülmektedir. Bu nedenle, matematik öğretmenlerinin öğrenme stiline önemine inanması, temellerini içselleştirmesi gerekir. Bu yolla öğrenme stiline dayalı öğrenme süreci tasarımları ve geliştirmeleri gerçekleştirilebilir. Öğretmenlerin sınıf içerisindeki tüm öğrencilerine ulaşabilmeleri için onların öğrenme stillerinden haberdar olmaları gerekir. Öğrencilerin matematik öğrenme stillerini dikkate alarak düzenlenmiş sınıf ortamlarının, öğrencilerin büyük kısmının önyargılı olarak yaklaştığı matematik dersine yönelik tutumlarını olumlu yönde geliştireceği açıktır. Dersle yönelik tutumunda öğrencilerin derslerdeki başarılarını etkileyen bir etmen olduğu unutulmamalıdır.

KAYNAKLAR

- Akın, F. (2002). *İlköğretim 4,5,6,7 ve 8. Sınıf Öğrencilerinin Matematik Dersine Yönelik Tutumlarının Çeşitli Değişkenlere Göre İncelenmesi*, Yayınlanmamış Yüksek Lisans Tezi, Pamukkale Üniversitesi, Denizli.
- Albayrak, Y. (2008). *Sağlık meslek lisesi öğrencilerinin öğrenme stilleri ile matematik dersine karşı tutumları arasındaki ilişki*. Yayınlanmamış Yüksek Lisans Tezi, Bolu, Abant İzzet Baysal Üniversitesi Sosyal Bilimler Enstitüsü
- Aydın, Ş. (2007). *Veri madenciliği ve Anadolu üniversitesi uzaktan eğitim sisteminde bir uygulama*. Yayınlanmamış Doktora Tezi, Anadolu Üniversitesi Sosyal Bilimler Enstitüsü
- C. Romero, S. Ventura, and P. De Bra, "Knowledge discovery with genetic programming for providing feedback to courseware author," *User Model. User-Adapted Interaction: J. Personalization Res.*, vol. 14, no. 5, p. 425-464, 2004.
- Felder, R. (1996). Matters of Style, *ASEE Prism*, 6(4) 18-23.
- Forster, P.A. (1999). *How do I Actually Learn? A Questioner for (co) Practipatory Learning in the Presence of Tecnolcy*. Proceedings Western Australian Institute for Educational Research Forum.
- Garg, S., & Sharma, A. K. (2013). Comparative Analysis of Data Mining Techniques on Educational Dataset. *International Journal of Computer Applications*, 74.
- Güntürkün, F. (2007). "A comprehensive review of data mining applications in quality improvement." Yayınlanmamış yüksek lisans tezi, Ortadoğu Teknik Üniversitesi Fen Bilimleri Enstitüsü, Ankara.
- Han, J., Kamber, M., & Pei, J. (2006). *Data Mining: Concepts And Techniques* (2nd.Edition).San Francisco: Morgan Kaufmann
- Karasar, N. (1998). *Bilimsel Arastırma Yöntemi*. Ankara, Nobel Yayın Dağıtım.
- Küçükahmet, L. (2000). *Öğretimde planlama ve değerlendirme*. (11. Baskı). Ankara: Nobel Yayınları.
- Pandey, U. K., & Pal, S. (2011). A Data Mining view on Class Room Teaching Language. *International Journal of Computer Science Issues (IJCSI)*, 8(2).

Seferođlu, S. S., 2004, Öğretmen Adaylarının Öğretmenliğe Yönelik Tutumları. XII. Ulusal Eğitim Bilimleri Kongresi Bildirileri. Ankara: 413-425

Tezbaşaran, A. (1996). *Likert tipi ölçek geliştirme kılavuzu*. Ankara: Türk Psikologlar Derneđi Yayınları

PROJECT MATHS IN IRELAND: THE EFFECT ON INTERNATIONAL STUDENTS

Mark PRENDERGAST
Dublin Institute of Technology
mark.prendergast@dit.ie

ABSTRACT: Project Maths is an ambitious reform of Irish post-primary education. It involves changes to what students learn in mathematics, how they learn it and how they will be assessed. There is a much greater emphasis placed on student understanding of mathematical concepts, with increased use of contexts and applications that will enable students to relate mathematics to their everyday experiences. The assessment reflects the different emphasis on problem solving and applications in the teaching and learning of mathematics and there is a much greater emphasis on reading and understanding the problems. Hence there is a greater emphasis on student's English language proficiency. This study aims to investigate the effect of Project Maths on International students studying in Ireland who do not speak English as their first language.

Key words: Project Maths, International Students, Language and Mathematics

INTRODUCTION

In Ireland formal education takes place in three stages. After completing eight years of primary education all students progress to the second level system. Second level education is typically of six years and during this time students complete two main State examinations namely the Junior Certificate (JC) and the Leaving Certificate (LC) examinations. These examinations can be taken at three levels with the upper level referred to as Higher, the next level referred to as Ordinary, and the lowest level that can be taken referred to as Foundation. Students can gain entry to Higher Education Institute's (HEI's) depending on how well they perform in the LC examinations. In this system the importance of mathematics is recognised by students, teachers and policy makers alike. Its inclusion as a compulsory subject in schools has widespread support (National Centre for Curriculum and Assessment (NCCA), 2005a) and students who achieve at least a D3 in Higher level LC mathematics examinations are awarded bonus marks (Central Applications office (CAO) - www.cao.ie).

However despite this importance, numerous concerns have been highlighted throughout the literature in recent years regarding mathematics educational strategy in Ireland. These concerns include class time, class and teacher allocation, difficult content, traditional assessment and an out of date curriculum (Prendergast and O'Donohue, 2014). Until recently, changes to this curriculum had not taken place since the 1960's when, even then, a major review of the Irish mathematics syllabuses at second level was undertaken highlighting "*mathematical structures, abstraction and rigorous presentation*" (Oldham, 1993 as cited in Lyons et al., 2003:5). These syllabuses resulted in a highly didactic and procedural approach to mathematics teaching in Ireland (NCCA, 2005b). There was a formal, behaviourist style evident that consisted of whole class teaching and the repetition of skills and procedures demonstrated by the teacher (Morgan and Morris, 1999). This resulted in students learning the 'how' rather than the 'why' of mathematics (Prendergast and O'Donohue, 2014). There was little or no emphasis on students' understanding the mathematics they were taught or indeed relating it to everyday life (Lyons et al., 2003). These concerns were compounded by the low numbers of students studying Higher level mathematics. For example in 2010, figures show that only 45 per cent of the Junior Cycle cohort took the JC Higher level mathematics' examination (State Examinations Commission (SEC) - www.examinations.ie). More worryingly only 16 per cent opted for the Higher level LC examination (SEC- www.examinations.ie). These figures are also very low in comparison to other subjects. For example, in the same year 68 per cent of students took Higher Level English in the JC examination, while 64 per cent took Higher level English in the LC examination (SEC- www.examinations.ie). To further compound this problem, 10 per cent of students failed Ordinary level mathematics in their LC examination in 2010 (SEC- www.examinations.ie).

As a result of such poor performance in mathematics by second level students, concern is widespread in many Irish HEI's regarding the mathematical under - preparedness of their entrant's. This does not just affect mathematics courses, but also impacts on other courses such as science, technology, engineering, business and finance where mathematics provides an important basis for development. This has serious repercussions for the

Irish economy, particularly in relation to the technology and industrial sectors (Expert Group on Future Skills Needs (EGFSN), 2008).

The Irish Government has been under increased pressure to take action as a result of such concerns. There was a stark realisation that the syllabuses and teaching methods were inadequate in providing students with the skills and knowledge which the twenty first century requires. Mathematics teaching today must emphasise the process of learning, applications of mathematics to the everyday world and problem solving (NCCA, 2005b). In order to achieve this aim and help solve the ‘maths problem’, the Irish Government have introduced a major new initiative in second level schools called Project Maths.

Project Maths

Project Maths overall aim is to teach mathematics in a way which leads to real understanding (Department of Education and Skills (DES), 2010a). It involves changes to what students learn in mathematics, how they learn it and how they will be assessed (www.projectmaths.ie). The initiative is designed to ensure an appropriate balance between understanding mathematical theory and concepts and developing practical applications skills. There is a much greater emphasis placed on student understanding of mathematical concepts, with increased use of contexts and applications that will enable students to relate mathematics to their everyday experiences. The focus is on students understanding the concepts involved, building from the concrete to the abstract and from the informal to the formal, and learning to apply their knowledge in familiar and unfamiliar contexts (DES, 2010a).

The Junior and Senior Cycle syllabuses are divided into five strands namely, Statistics and Probability; Geometry and Trigonometry; Number; Algebra; and Functions. After an initial pilot phase beginning with 24 schools in 2008, it was rolled out nationally in 2010. Changes are being phased in over a number of years covering all 5 strands of mathematics, with assessment in the examinations being adapted as each strand of mathematics comes on stream. The assessment reflects the different emphasis on problem solving and applications in the teaching and learning of mathematics and there is a much greater emphasis on reading and understanding the problems. It is an objective of Project Maths to increase the uptake of Higher level mathematics at LC to 30 per cent and to 60 per cent at JC (Cosgrove et al., 2012). While Strands 1 and 2 of the revised syllabi were first examined in 2012 at LC level in all schools, the phased implementation means that it will be 2017 before a first cohort of students who have experienced all 5 strands of Project Maths from 1st to 6th year will be examined. Thus it is very early to make any conclusions regarding the successes / failures of the initiative. However, an interim report commissioned by the NCCA and conducted by the National Foundation for Educational Research (NFER, UK) has been published and includes findings on students’ attitudes and achievements. Overall this report found that there is emerging evidence of the positive impacts of Project Maths on students’ experiences of, and attitudes towards, mathematics (Jeffers et al., 2013). Furthermore, students’ are achieving more at individual strand level, and in some instances students appear to be successfully drawing together their knowledge across different mathematics topics (Jeffers et al., 2013). This suggests that students are beginning to acquire a deeper understanding of mathematics and how it can be applied (Jeffers et al., 2013).

However, despite such emerging evidence of the positive impacts on students’ experiences of, and attitudes towards, mathematics, many challenges remain for Project Maths. The majority of these challenges centre on the manner of the implementation process and the availability of teaching and learning resources. However concern has also been expressed regarding the perceived literacy demands of the revised mathematics syllabus (Cosgrove et al., 2012; Jeffers et al., 2013). Such concerns highlight the importance of language and literacy in the teaching and learning of mathematics.

Language and Mathematics

Mathematics can be recognised as a language in its own right, a language which has its own vocabulary, grammar, symbols and punctuation (Ellerton and Clarkson, 1996). The teaching of mathematics, however, takes place within a spoken language, such as English (Zevenbergen, 2001). This spoken language is an essential element of the teaching and learning of the subject (Gorgorió & Planas, 2001). It is the vehicle of communication within a mathematics classroom and provides the tool for teacher – student interactions (Smith and Ennis, 1961). Language permits mathematics learners to ask and answer questions, to convey their understanding and to discuss their answers with others. It also plays a significant role in the processing of mathematical text and the interpretation of questions (Hoosain, 1991). This is now particularly relevant in Ireland with the introduction of Project Maths where there is far greater emphasis solving word problems and applications. Students are required to translate every day problems into mathematics, solve them and then clarify their answers in the context of the original problem. Many teachers feel that students with low literacy levels and particularly non – national students for whom English is not a first language are struggling with

comprehension of this material and the wordy nature of some of the questions (Cosgrove et al., 2012). *'the language used when phrasing a question poses a major problem for students whose literacy skills would be weak, they can therefore not answer a question they are mathematically capable of doing! This is a major issue!'* (Cosgrove et al., 2012:72). Many students (including those studying at Higher Level) have also expressed difficulties interpreting word based problems and with providing written explanations for their solutions to mathematical problems (Jeffers et al., 2013). Students also appear to lack confidence when asked to draw conclusions from a considerable amount of written information (Jeffers et al., 2013).

THE STUDY

Approximately 1.7 million students, almost half of whom are from non – English speaking developing nations in Asia, cross borders every year to acquire a foreign education (Sawir, 2005). In Ireland, the percentage of international students has increased from 3 per cent in 2002 to 10 per cent in 2012 (Perkins et al., 2013). The Government aims to increase this further as it bids to promote the internationalisation of the Irish Higher Education sector and to significantly increase the proportion of fee paying international students as a means to diversify the income base for HEI's (DES, 2010b). This need to diversify the income base of institutions was further restated in the Hunt Report specifically referencing income generated from the recruitment of fee paying international students (Hunt, 2011). However, the increased arrival of international students has also coincided with the introduction of Project Maths in second level schools and its high emphasis on literacy and the English language. Of the 10 per cent of students in Ireland classified as international, about half speak languages other than Irish or English at home (Perkins et al., 2013). This research aims to investigate the effect (if any) which Project Maths has on International students and to view the initiative from their perspective.

METHODS

The authors decided to use a mixed method approach by combining both qualitative and quantitative methods of research. The use of multiple methods was decided upon in order to get an in-depth understanding of the research. The study evaluates International student's opinions of Project Maths and compares their scores in a traditional style mathematics examination with their scores in a Project Maths style examination.

Participants

The participants for this study comprised of 41 International students who were enrolled in an International Foundation Programme in an Irish HEI. Mathematics is one of six core year-long subjects that all students are required pass, along with two elective choices, in order to complete the programme. Upon successful completion of the programme, students are granted direct entry onto an undergraduate programme of their choice in the HEI. The aim of the programme is to equip them with the skills to meet the minimum entry requirements of such undergraduate programmes. All of the students who participated in the study originated from either Saudi Arabia or Oman and all spoke Arabic as their first language. Thus for many of these students, the main skills required involve improving their English language proficiency. This proficiency is measured using the International English Language Testing Score (IELTS). The IELTS is an internationally standardised 9-band scale. Each band corresponds to a level of English competence. All parts of the test (listening, reading, writing, speaking) and the Overall Band Score can be reported in whole and half bands, for example 6.5, 7.0, 7.5, 8.0.

In order to gain entry onto the Foundation Programme students must have an IELTS of at least level 5.0 or one whole band below the entry requirements of their undergraduate destination. Students with an IELTS of 5 are defined as modest English language users (www.ielts.org). They should have a partial command of the language, and although they are likely to make many mistakes, they should be able to cope with the overall meaning in most situations. Students with an IELTS of 6 are defined as competent English language users (www.ielts.org). They should have a generally effective command of the language despite some inaccuracies and misunderstandings. They should be able to use and understand fairly complex language, particularly in familiar situations. 58.5 per cent of the students who participated in this study had an overall IELTS of 5 and 24.4 per cent had an overall IELTS of 5.5. The remaining students had an overall IELTS of between 6 and 7.5.

The participants were predominately male (80 per cent) and ranged in age from 18 – 24 years old. 61 per cent of the participants were aged between 18 – 19 years old. All of the data was collected by the author in September 2013 in the participants first academic week of the programme.

Quantitative Data

In order to get a quantitative measure on the effect of Project Maths on International students the author decided to compare the scores of students in Project Maths style examination (Exam A) with their scores in a traditional style mathematics examination (Exam B). Each examination comprised of ten questions from the Junior Cycle Number strand and each question was taken from Irish second level textbooks and previous State examination papers. Students had 50 minutes to complete each examination. The questions in Exam A were based on the Project Maths method of assessment and thus reflected the emphasis on understanding, problem solving and applications. The questions in Exam B were technically the same questions from Exam A but were mathematical procedure and skill based only with the removal of any context or language. For example:

Exam A - Question 3

Usain Bolt, the fastest man on earth, has a stride length of $2\frac{4}{5}$ m when he is at full stride. In a 100m sprint, how many strides would Usain take to cover the final 30m when he is at full stride?

Exam B - Question 3

Evaluate $30 \div 2\frac{4}{5}$

Students completed Exam A first and then Exam B directly afterwards. Ten marks were awarded per question. Both examinations were corrected by a qualified Irish second level mathematics teacher who has six years experience in correcting State examinations. Each student received a mark out of 100 for each examination.

At the end of Exam B, there were also three closed ended questions which all participants were invited to answer. The questions enquired about which examination the participants preferred; which examination did they find more difficult; and whether their English language skills had negatively affected their ability to answer questions in either of the exams. These questions were further expanded upon more in the focus group.

Qualitative Data

In order to get feedback regarding International student's opinions of Project Maths, a focus group was conducted with eight students who volunteered from the examination participants. This focus group was conducted two days after the students completed the examinations. The quantitative findings from the examinations and closed ended questions were considered. Each student was coded to ensure confidentiality (P1 – P8). Their responses were transcribed and analysed using NVivo software and arranged into themes by the author and a mathematics education colleague.

RESULTS AND FINDINGS

Quantitative Data

Descriptive analysis of the data shows that the students performed poorer in Exam A (M: 41.49; SD: 18.06) in comparison to Exam B (M: 63.59; SD: 16.84). A paired- samples t – test found that there was a statistically significant difference in the performance of students in both examinations ($t(41) = -9.89, p = .000$). Further analysis of the data found that in Exam A, students with an IELTS of 5.5 (M: 52.60; SD: 15.36) performed much better than those with an IELTS of 5.0 (M: 34.08; SD: 16.41). An independent – samples t – test also found that these differences were statistically significant ($t(41) = -3.05, p = .005$). Such differences were not evident in Exam B where students with an IELTS of 5.5 (M: 67.00; SD: 11.79) and an IELTS of 5.0 (M: 63.45; SD: 14.47) in Exam B performed similarly.

The data collected from the three closed ended questions at the end of Exam B shows that 80.5 per cent of the participants preferred Exam B. 95.1 per cent found Exam A more difficult and 82.9 per cent felt that their English language skills had negatively affected their ability to answer questions in either of the exams.

Quantitative Data

Participants of the focus group gave a number of reasons why the majority of the participants preferred Exam B.

P4: *'because it was straight forward'*.

P6: *'there were no words which I can't understand'*.

P7: *'I didn't have to translate the words; I could understand the method directly by the numbers'*.

However some also gave explanations why they preferred Exam A.

P2: *'it makes you think of the actual situation and it improves our English at the same time. Also, it's more fun than seeing a paper filled with numbers'*.

P3: *'because it helps us improve our language and our reading and it makes us understand what we need'*.
P8: *'it gave me the chance to use math in real life'*.

There was a general conclusion amongst participants that Exam A was more difficult. Language and literacy levels were the foremost factors.

P1: *'in Exam A, most of the questions I didn't understand because I didn't know some words. It had hard expressions that an International student whose English is his second language wouldn't be able to understand'*.

P8: *'the questions were written in a different language and that was the hard part. Understanding the question is half if the answer as we say in Arabic'*

P6: *'Sometimes I think I had the solution, but because I did not understand the question, I solved it in the wrong way'*.

P4: *'some of the language was not familiar - the questions were like complicated short stories. Sometimes I could understand the words but found it hard to explain the answer'*.

The allocated time was also consistently mentioned as a factor which made Exam A more difficult.

P3: *'in Exam A there is a lot of reading questions and it takes a long time to solve it especially for non – speaking English student'*.

P8: *'Exam B was just numbers while Exam A was like reading English paragraphs which took more time'*.

P2: *'we need to read the question many times to understand it and that may lose time'*.

Overall their opinion of Project Maths was very positive.

P2: *'I think it is great because you can apply it in your daily use. I would like to see how it turns out because I think it has a bright future and it could change the way of teaching math all over the world'*.

P3: *'I think it is enjoyable and good idea because we will use it in real life or work to solve problems and it helps us to improve our language'*.

P8: *'I think it's a good practice to know how to use math, so the student will be able to solve real life problems using math. It also combines our language skills and our maths skills'*.

However some did express reservations about the difficulty of Project Maths particularly for International students.

P8: *'the questions are more difficult to answer for International students when English is not first language'*

P7: *'it might fail lots of students due to their lack of English'*.

P4: *'it's difficult to understand the language as we are not native speakers. If I have good English I can answer it, if not, I will face some difficult things'*.

Several participants offered suggestions about what could be done to help International students become more accustomed to the changes brought about by Project Maths.

P1: *'Keep the language of the questions basic. Don't use strong language that not everyone can understand'*.

P2: *'I think if there was a class to teach math language and improve our language at the same time. Maybe more projects and discussion to give us more practice in English language in Maths'*.

P7: *'we must improve our language - maybe classes where they just learned math vocab'*.

CONCLUSION

Similar to the findings of the 'Research into the impact of Project Maths on student achievement, learning and motivation' (Jeffers et al., 2013) and 'Teaching and Learning in Project Maths: Insights from Teachers who Participated in PISA 2012' (Cosgrove et al., 2012) reports, this study highlights concern for non – national students for whom English is not a first language in how they manage the high literacy demands of Project Maths. The heavy emphasis on English language in the problem solving and application questions is difficult for International students. Statistically significant differences were found in the results of student scores in a traditional style mathematics examination with their scores in a Project Maths style examination. There was also statistically significant differences in the scores of students in the Project Maths style examination who had an IELTS of 5.5 compared to those who had an IELTS of 5.0. This shows that student's language levels were a main factor. To support this, 82.9 per cent of participants felt that their English language skills had negatively affected their ability to answer questions in either of the mathematics exams. These findings highlight the importance that language has on the teaching and learning process. A student can have excellent mathematical ability but this is futile unless they can communicate effectively with their teacher and their peers and can competently understand the language in which they are being taught and examined.

RECOMMENDATIONS

This study does not wish to convey negativity towards Project Maths. Indeed, the students of the focus group had very positive opinions of the initiative. However, it does wish to highlight that more needs to be done to cater for non – national students for whom English is not a first language, to ensure that they are not disadvantaged by Project Maths. The number of these students enrolling in Irish HEI’s has soared in recent years. It is important that they are given every opportunity to succeed. Further research in this area is needed, but the author feels that Foundation Year Programmes for International students run by Irish HEI’s have a major role to play here. These programmes help improve English language skills through traditional classes, tutorials and group work as well as the immersion of students in the day to day life of an Irish HEI. The teaching and assessment of all subjects such as mathematics through English is of great benefit. For mathematical learners, this is twofold. Students gain competence in the language of instruction and also the language of mathematics. Furthermore students enrolled in International Foundation Programmes are introduced to the learning styles which will be expected of them in Irish HEI’s. Many students encounter problem solving, applications, discussion and debate for the first time. These are all important components of Project Maths. As mentioned, further research is needed to validate these opinions. The author plans to carry out a longitudinal study to investigate whether international students are better equipped for Project Maths at the end of their year-long Foundation programme and how this helps them make a successful transition to Irish third level education.

REFERENCES

- Central Applications Office (CAO) [online], available: www.cao.ie [accessed April 2014].
- Cosgrove, J., Perkins, R., Shiel, G., Fish, R., & McGuinness, L. (2012). *Teaching and Learning in Project Maths: Insights from Teachers who Participated in PISA 2012*, Dublin: Educational research Centre.
- Department of Education and Skills (2010a). *Report of the Project Maths Implementation Support Group*, Dublin: Department of Education and Skills.
- Department of Education and Skills (2010b). Investing in Global Relationships – Ireland’s International Education Strategy 2010 – 15, *Report of the High-Level Group on International Education to the Tánaiste and Minister for Education and Skills*, Dublin: Department of Education and Skills.
- Ellerton, N.F. and Clarkson, P.C. (1996). Language factors in mathematics teaching and learning, in A.J. Bishop et al (Eds.) *International handbook of mathematics education* (pp. 987-1033). The Netherlands: Kluwer Academic Publishers.
- Expert Group on Future Skills Needs (2008). *Statement on Raising National Mathematical Achievement*, Dublin: EGFSN.
- Gorgorió, N. and Planas, N. (2001). ‘Teaching mathematics in multilingual classrooms’, *Educational Studies in Mathematics*, 47(1), pp.7-33.
- Hoosain, R. (1991). *Psycholinguistic Implications for Linguistic Relativity: A Case Study of Chinese*. Hillsdale, NJ: Lawrence Erlbaum.
- Hunt, C. (2011). National Strategy for Higher Education to 2030 - Report of the Strategy Group, Dublin: Department of Education and Skills.
- International English Language Testing Score (IELTS) [online], available: www.ielts.org [accessed April 2014].
- Jeffes, J., Jones, E., Wilson, M., Lamont, E., Straw, S., Wheatler, R. and Dawson, A. (2013). *Research into the impact of Project Maths on student achievement, learning and motivation: final report*. Slough: NFER.
- Lyons, M., Lynch, K., Close, S., Sheerin, E. and Boland, P. (2003). *Inside Classrooms- The Teaching and Learning of Mathematics in the Social Context*, Dublin: Institute of Public Administration.
- Morgan C. and Morris, G. (1999) *Good Teaching and Learning: Pupils and Teachers Speak*, London: Open University Press.
- National Council for Curriculum and Assessment (2005a). *Review of Mathematics in Post – Primary Education*, Department of Education and Science, Dublin: The Stationary Office.
- National Council for Curriculum and Assessment (2005b). *International Trends in Post – Primary Mathematics Education* [online], available: <http://www.ncca.ie/uploadedfiles/mathreview/intpaperoct.pdf> [accessed March 2014].
- Perkins, R., Shiel, G., Merriman, B., Cosgrove, J. and Morgan, G. (2013). *Learning for Life: The Achievements of 15 year olds on Mathematics, Reading Literacy and Science in PISA 2103*, Dublin: Educational Research Centre.
- Prendergast, M. and O’Donoghue, J. (2014). ‘‘Students enjoyed and talked about the classes in the corridors’’: pedagogical framework promoting interest in algebra’, *International Journal of Mathematical Education in Science and Technology (IJMEST)* [online] available: <http://www.tandfonline.com/doi/full/10.1080/0020739X.2013.877603>.
- Sawir, E. (2005). Language Difficulties of International Students in Australia: The Effects of Prior Learning Experience. *International Education Journal*, 6(5), 567-580.

- Smith, B. O and Ennis, R. H. (1961). *Language and concepts*. Chicago: Rand McNally & company.
- State Examinations Commission (SEC) [online], available: www.examinations.ie [accessed April 2014].
- Zevenbergen, R. (2001). Changing contexts in tertiary mathematics: implications for diversity and equity, in D. Holton (Ed.) *The Teaching and Learning of Mathematics at University Level, An ICMI Study*. Dordrecht, The Netherlands: Kluwer Academic Publishers.

ÖĞRETMEN ADAYLARININ TEMEL MATEMATİKSEL İFADELERİN DOĞRULUĞUNA YÖNELİK GÖRÜŞLERİ

Şahin DANIŞMAN
Eskişehir Osmangazi Üniversitesi
sahin.danisman@gmail.com

Emre EV ÇİMEN
Eskişehir Osmangazi Üniversitesi
evcimen@ogu.edu.tr

ÖZET: Matematiğin temel yapı taşlarından birisi olan ispat, öğrencilerin kavramları daha iyi anlamalarına ve matematiksel düşünce yapılarını geliştirmelerine katkı sağlamaktadır. Matematiksel düşünmede önemli rol oynayan ispat sürecinde, bir önermeyi açıklama, neden doğru veya yanlış olduğunu söyleme ve değişik mantıksal düşünme yollarını ve ispat çeşitlerini seçme ve kullanma gibi eylemler söz konusudur. İspatlar, sadece bir ifadenin doğruluğunu göstermekle kalmaz, aynı zamanda öğrencilerin kavramları daha iyi anlamasına ve matematiksel algı ve anlayışlarının gelişmesine yardımcı olur. Bu bakımdan, ispat süreci matematik öğretim programının ayrılmaz bir parçası olup öğrencilerin bu süreçte, ispat yapma becerilerini kazanmaları gerekmektedir. Bu noktada ise, öğretmenlere önemli bir rol düşmektedir. Öğretmen adaylarının öğrencilerini eleştiren, araştıran, sorgulayan ve muhakeme eden bireyler olarak yetiştirmeleri açısından öğrenim hayatlarında sorgulama ve ispat yapma becerilerini geliştirmeleri önemli görülmektedir. Bu araştırma, öğretmen adaylarının eğitimleri süresince karşılaştıkları ve ileride mesleki yaşamlarında yaygın bir biçimde kullanacakları sayı ve kesirler ile ilişkili bazı temel matematiksel ifadelerin doğruluğu hakkındaki görüşlerini belirlemeyi amaçlamaktadır. Bu amaca yönelik olarak durum çalışması deseni kullanılmış olup, 133 kadın ve 31 erkek olmak üzere toplam 164 öğretmen adayından yapılandırılmış görüşme formlarıyla veri toplanmıştır. Öğretmen adaylarından, görüşme formunda yer alan temel matematiksel ifadelere (Örn: “Her sayının sıfırncı kuvveti 1’dir; Her sayının sıfıra bölümü tanımsızdır; Üslü sayılarda çarpma işlemi yapılırken üsler toplanır” gibi.) yönelik düşüncelerini gerekçeleri ile birlikte belirtmeleri istenmiştir. Araştırmada elde edilen verilerin analizi sonucunda, öğretmen adaylarının çoğunun temel matematiksel gerçeklikleri sorgulamadıkları ve bu gerçeklikleri ispatlama konusunda da yetersiz oldukları ortaya çıkmıştır. Öğretmen adaylarından bazılarının, ilköğretimden itibaren öğretmenlerinin söylediklerini sorgulamadan ezberlediklerini ifade etmeleri ve bazı ifadelerde sayı kümelerine dikkat etmeden gerekçelendirme sunmaları ilginç bulgular arasındadır. Çalışma sonunda öğretmen adaylarının yorumları incelendiğinde, matematikte temel olan bu tür temel gerçeklikleri sorgulamaları konusunda merak ve farkındalık oluşturulduğu sonucuna ulaşılmıştır.

Anahtar sözcükler: Matematik eğitimi, ispat, sorgulama becerileri

HİZMET ÖNCESİ FEN ÖĞRETMENLERİNİN LİSE ÖĞRENİMLERİNDEKİ LABORATUVAR YAŞANTILARI

PRESERVICE SCIENCE TEACHERS' LABORATORY EXPERIENCES DURING HIGH SCHOOL EDUCATION

Yrd. Doç. Dr. Emine ÇİL
Muğla Sıtkı Koçman Üniversitesi
enimeonyedi@hotmail.com

Hazel KAR
Muğla Sıtkı Koçman Üniversitesi
heyzilk988@hotmail.com

Funda Gül İRİ
Muğla Sıtkı Koçman Üniversitesi
fndaglr3409@hotmail.com

Seda ŞAHİN AKYÜZ
Muğla Sıtkı Koçman Üniversitesi
sedas-14@hotmail.com

Durmuş YANMAZ
Muğla Sıtkı Koçman Üniversitesi
durmusyanmaz@mu.edu.tr

ÖZET: Öğrencilerin fen kavramlarını derinlemesine ve anlamlı öğrenmelerinde laboratuvar uygulamalarının etkili bir yol olduğu sıklıkla vurgulanmaktadır. Bu çalışmanın amacı, hizmet öncesi fen öğretmenlerinin lise öğrenimlerinde laboratuvar yaşantılarını ortaya çıkarmaktır. Çalışmaya 2012-2013 Eğitim-Öğretim yılında Muğla Sıtkı Koçman Üniversitesi, Eğitim Fakültesi, İlköğretim Eğitimi Bölümü, Fen Bilgisi Öğretmenliği Anabilim Dalı 1. sınıfında öğrenim gören 120 öğrenci katılmıştır. Çalışmanın verileri öğrenci kompozisyonlarıyla toplanmıştır. Öğrenciler kompozisyonlarında açık uçlu soruları yanıtlamışlardır. Öğrencilerin kompozisyonlarında yazmış oldukları açıklamaları daha iyi anlamak için rastgele seçilen 10 öğrenciyle yarı yapılandırılmış mülakat yürütülmüştür. Elde edilen nitel verilerin analizinde betimsel analiz ve içerik analizi kullanılmıştır. Okulda laboratuvar bulunmaması, var olan laboratuvarların fiziki koşullarının yetersiz olması, öğretmenlerin laboratuvar kullanımında yetersiz olması gibi nedenlerden ötürü öğrencilerin laboratuvar yaşantılarının çok az olduğu tespit edilmiştir. Elde edilen bulgulara dayalı olarak şunlar önerilebilir: Liselerde görev yapmakta olan fizik, kimya ve biyoloji öğretmenlerinin laboratuvarları daha etkili kullanmalarına yönelik eğitimler tasarlanıp uygulanabilir.

Anahtar sözcükler: fen öğretimi, hizmet öncesi fen öğretmenleri, laboratuvar yaşantıları

ABSTRACT: It is highly emphasized that laboratory experience is an effective way to teach science notions deeply and substantially. The aim of this work is to reveal the laboratory experiences which the science teachers receive in preservice period during high school education. 120 First Grade students who study at The Faculty of Education, Primary School Education, Science Teaching Department in Muğla Sıtkı Koçman University attended in this work in 2012-2013 Academic Year. The data of the work was collected from the essays which were written by these students. The students answered some open ended questions in their essays. In order to understand these essays a semi constructed interview was conducted among 10 students that were chosen randomly. Descriptive analysis and content analysis were used while analysing the qualitative data that was gained. It is founded that laboratory experiences of children are very limited due to the reasons such as the lack of labs in schools, the inadequacy of the labs in schools or the inadequacy of the lab teachers. These can be offered according to the findings of this work: some seminars can be given to the high school teachers who give the science, chemistry and biology lessons in order to make them use the labs more efficeintly.

Key words: science education, preservice science teachers, laboratory experiences

GİRİŞ

Labratuvar uygulamalarının yaparak ve yaşayarak öğrenme ortamları sağladığı bu sayede edinilen bilgilerin derin izli ve uzun süre kalıcı olduğu sıklıkla vurgulanmaktadır (Can, 2012; Güneş, Şener, Topal Germi ve Can, 2013; Karaca, Uluçınar ve Cansaran, 2006; Sürücü, Özdemir, Bilen ve Köse, 2013). Özellikle anlamakta zorluk çekilen soyut fen kavramları öğrencilerin bizzat üzerinde çalışması sağlanarak somutlaştırılabilir (Ayas, 1998; Güneş vd., 2013; Kocakulah ve Savaş, 2011).

Fen bilimleri deney ve gözlemi ön planda tutması bakımından diğer bilimlerden ayrılır (Can, 2012). Deneyerek, görerek, araştırarak, inceleyerek, tartışarak öğrenme ortamı sağlanan bireylerin olaylar karşısındaki tutumları, problem çözme becerileri klasik yöntemlerle yetişen bireylerden farklı olacaktır (Güneş vd., 2013; Taşkın Ekici, Ekici ve Taşkın, 2002). Doğru ve etkili bir şekilde yürütülen labratuvar uygulamaları fene karşı olumlu tutum gelişmesine ve istenilen öğretim hedeflerine daha kolay ulaşılabilmesine katkılar sağlayacaktır (Kaya ve Büyük, 2011; Yeşilyurt, 2006). Bu noktada fen öğretiminde labratuvarın etkili bir şekilde kullanılmasında öğretmenlere büyük görevler düşmektedir (Feyzioğlu, Demirdağ, Ateş, Çobanoğlu, Altun ve Akyıldız, 2011).

İlgili literatürde sınıf mevcutlarının kalabalık olması, yetersiz malzeme, labratuvar uygulamalarına ayrılan sürenin yetersiz olması, öğretmenlerin labratuvar kullanmadaki yetersizlikleri gibi nedenlerle labratuvar uygulamalarına yeterince yer verilmediği görülmektedir (Feyzioğlu vd., 2011; Güneş vd., 2013).

Bu çalışmanın amacı, hizmet öncesi fen öğretmenlerinin lise öğrenimindeki labratuvar yaşantılarını ortaya çıkarmaktır. Çalışmadan elde edilen bulgular liselerde fen bilimleri, fizik, kimya, biyoloji gibi derslerin nasıl öğretildiği hakkında ipuçları sağlayabilir. Bu çalışma hizmet öncesi fen öğretmenlerinin labratuvar uygulamalarından neler beklediklerini ortaya çıkarabilir. Eğitim Fakültelerindeki öğretmen eğitimcileri labratuvar derslerini planlarken öğrencilerin beklentilerini göz önüne alabilirler.

YÖNTEM

Model

Bu çalışmada tarama modeli kullanılmıştır. Tarama modeli, bir konuya ya da olaya ilişkin, katılımcıların görüşlerinin ya da ilgi, beceri, tutum vb. özelliklerinin belirlenmesini sağlar (Büyüköztürk, Kılıç Çakmak, Akgün, Karadeniz ve Demirel, 2008, 177).

Çalışmanın Örnekleme

Çalışmaya 2012-2013 Eğitim-Öğretim yılında Muğla Sıtkı Koçman Üniversitesi, Eğitim Fakültesi, İlköğretim Eğitimi Bölümü, Fen Bilgisi Öğretmenliği Anabilim Dalı 1. sınıfında öğrenim gören 120 öğrenci katılmıştır. Katılımcıların yaklaşık %75' i lise öğrenimlerini düz lisede tamamlamışlardır.

Veri Toplama Araçları

Çalışmanın verileri öğrenci kompozisyonlarıyla toplanmıştır. Öğrenciler kompozisyonlarında açık uçlu soruları yanıtlamışlardır. Bu sorulardan bazıları şunlardır: Okuduğunuz lisede fen labratuvarı var mıydı? Eğer varsa labratuvarın fiziki koşulları nasıldı?, Lise öğreniminiz boyunca fen derslerinde labratuvardan hangi sıklıkta yararlandınız?, Fen öğretmeniniz labratuvarda daha çok hangi yöntem teknikleri kullanırdı?, Fen dersleri haricinde okulunuzdaki fen labratuvarından hangi sıklıkla, hangi amaçlarla yararlandınız?. Öğrencilerin kompozisyonlarında yazmış oldukları açıklamaları daha iyi anlamak için rastgele seçilen 10 öğrenciyle yarı yapılandırılmış mülakat yürütülmüştür.

Verilerin Analizi

Bu çalışmada elde edilen nitel verilerin analizinde betimsel analiz ve içerik analizi kullanılmıştır. “Betimsel analiz, elde edilen verilerin kodlanması, temalar halinde özetlenip yorumlanmasıdır. Bu analizde doğrudan alıntılara sık sık yer verilir. Bu analizin asıl amacı bireylerin görüşlerini çarpıcı bir şekilde yansıtmaktır. Betimsel analizde özetlenen ve yorumlanan veriler, içerik analizinde daha derin bir işleme tabi tutulur” (Yıldırım ve Şimşek, 2005, 224-227).

Öğrenci kompozisyonları tek tek incelenmiştir. Kompozisyonlar bir kaç defa okunmuştur. Bu sırada veriler kodlanmıştır. Elde edilen kodlardan alt temalar oluşturulmuştur. Her bir alt temanın frekans ve yüzde değerleri

hesaplanmıştır. Birbiriyle ilişkili olan alt temalar bir araya getirilerek temalar halinde düzenlenmişlerdir. Verilerin analizi iki araştırmacı tarafından bağımsız olarak yapılmıştır. Bir fen eğitimcisinin danışmanlığında bu iki analiz karşılaştırılmıştır. Analizlerin %95 tutarlı olduğu tespit edilmiştir. İki araştırmacının analizleri arasındaki tutarsızlıklar müzakere ile giderilmiştir.

BULGULAR

Bu bölümde verilerin analizinden elde edilen temalar ve alt temalar Tablo 1’ de sunulmuştur.

Tablo 1. Katılımcı Kompozisyonlarından Ortaya Çıkan Temalar ve Alt Temalar

Temalar	Alt Temalar	f	%
Okulun laboratuvar durumu	Okulda laboratuvar var	36	30
	Okulda laboratuvar yok	19	16
	Laboratuvarın fiziki koşulları yeterli	7	6
	Laboratuvarın fiziki koşulları yetersiz	25	21
Derslerin işlenişi	Fizik dersinin sunuş yoluyla öğretimi	97	81
	Kimya dersinin sunuş yoluyla öğretimi	82	68
	Biyoloji dersinin sunuş yoluyla öğretimi	69	58
	Fizik dersinin deneylerle öğretimi	12	10
	Kimya dersinin deneylerle öğretimi	13	11
	Biyoloji dersinin deneylerle öğretimi	31	26
Deneylerin yapılışı	Gösteri deneyi	19	16
	Grup deneyi	3	3
	Bireysel deney	4	3
	Deney okuma	13	11
	Deney yazma	3	3
	Ev ödevi verme	4	3
Laboratuvarın kullanımı (Deneyim)	Laboratuvar deneyimi var	21	18
	Laboratuvar deneyimi yok	39	33
	Sadece malzeme tanıtımı yapılmış	3	3
Laboratuvara karşı duygular	Korku	4	3
	Endişe	5	4
	Eğlenceli bulma	13	11
	Merak duyma	14	12
Laboratuvar yaşantılarından zihinde kalanlar	Deneyin adını hatırlama	15	13
	Deneyin yapılışını hatırlama	63	53
	Deney kazalarını hatırlama	5	4
Laboratuvar kullanımına yönelik eleştiriler	Öğretmenlerin laboratuvar kullanmadaki yetersizliği	35	29
	Malzemelere dokunmanın yasak olması	3	3
	Yöneticilerin eleştirilmesi	5	4
	Laboratuvarın amacı dışında kullanımı	3	3

Öğrencilerin %30’ unun öğrenim gördükleri lisede laboratuvar bulunmaktadır. Katılımcıların %16’ sının mezun olduğu lisede laboratuvar bulunmamaktadır. Katılımcıların yaklaşık olarak %20’ sinin öğrenim gördüğü lisede laboratuvar bulunmaktadır fakat laboratuvarın fiziki koşullarının yetersizdir. Katılımcıların sadece %6’ sı fiziki koşulları yeterli laboratuvara sahip lisede öğrenim görmüşlerdir.

Öğrencilerin çok büyük bir kısmı fen derslerinin sunuş yoluyla yapıldığını belirtmiştir. 97 kişi fizik derslerinin, 82 kişi kimya derslerinin, 69 kişi biyoloji derslerinin sunuş yoluyla öğretildiğini ifade etmiştir. Hatta öğrencilerden biri yaşantısını “Derste deney kelimesini bile kullanmazdık. (Ö-3)” şeklinde ifade etmiştir. Fizik ve kimya derslerinin deneylerle öğretildiğini söyleyen öğrenciler yaklaşık %10’ luk bir dilim oluştururken, biyoloji dersinin deneylerle öğretildiğini söyleyenler %26’ lık bir dilim oluşturmaktadır.

Deneylerin yapılışı hakkındaki görüşler incelendiğinde öğrencilerin yalnızca %3’ ünün bireysel veya grup deneyi yaptığı görülmektedir. Bu alt tema için öğrenci kompozisyonlarından bir örnek şöyledir: “Son sınıfta organik kimyada laboratuvarı kullandık. Gruplara ayrıldık. Her grupta olması gereken malzemeler olur ve hep beraber deneyi yapardık (Ö-112).” 19 kişi gösteri deneyleri ile ders işlendiğini söylemiştir. Derste deneyleri yapmayıp, deneylerin yapılışını okuduklarını söyleyen öğrencilerin oranı %11’ dir. Öğrencilerin 4’ ü deneylerin evde yapılması için ödev verildiğini söylerken, 3 kişi deneylerin uygulamalı olarak yapılmadığını, deneyleri yaparak geçtiklerini belirtmiştir.

Öğrencilerin yalnızca %18' i laboratuvar deneyiminin var olduğunu söylerken %39' u hiç laboratuvar deneyiminin olmadığını söylemiştir. Öğrenci kompozisyonlarındaki “Lise hayatım boyunca laboratuvar yüzü görmedim (Ö-98).” ifadesi bu alt temayı örneklendirmektedir. 3 öğrenci laboratuvar deneyimin olmadığını fakat malzeme tanıtımının yapıldığını söylemiştir.

Öğrencilerin yaklaşık olarak %5' i laboratuvar ortamında fen öğrenmekten korkmaktadır. Yine öğrencilerin yaklaşık olarak %5' i laboratuvar uygulamalarında başarısız olmaktan endişe etmektedir. Öğrencilerden biri korkusunu “Umarım üniversitede bocalamadan laboratuvar derslerinde başarılı olurum. Açıkçası korkularım, güvensizliğim var (Ö-5).” şeklinde ifade etmiştir. Öğrencilerin %11' i laboratuvar uygulamalarını eğlenceli bulmaktadır. Öğrencilerin %12' si laboratuvarı ve laboratuvarda birşeylerle meşgul olmayı merak etmektedirler.

Laboratuvar yaşantılarından zihinde kalanlar temasında baskın olan alt tema deneyin yapılışını hatırlamadır. Katılımcıların yarısından fazlası lise yaşantılarında yaptıkları deneylerin yapılışını hatırlamaktadır.

Laboratuvar kullanımına yönelik eleştirilerde 4 alt tema tespit edilmiştir. Öğrencilerden yaklaşık olarak %30' u lise öğrenimindeki öğretmenlerinin laboratuvarı etkili bir şekilde kullanmada yetersiz olduğunu düşünmektedir. Öğrencilerin yaklaşık olarak %5' i laboratuvar kullanımında yöneticileri eleştirmektedir. Öğrencilerden biri eleştirisini şu şekilde dile getirmiştir: “Bizim okulda laboratuvar milli eğitim müfettişlerine bakın laboratuvarımız var, her şeyimiz tamam demek içindi yani göstermeliydi (Ö-21).” Öğrencilerin yaklaşık olarak %5' i laboratuvar malzemelerinin öğrenciler tarafından serbestçe kullanılmasına izin verilmemesini eleştirmektedir. Bütün bunlara ek olarak laboratuvarın deney yapmak yerine sunuş yoluyla öğretim için kullanılması da eleştirilmektedir.

SONUÇ

Çalışmadan elde edilen bulgulara dayalı olarak liselerde fiziki koşulları yeterli laboratuvarların bulunmadığı söylenebilir. Yapılan bazı çalışmalar da bu sonucu destekler niteliktedir (Çallica, Erol, Sezgin ve Kavcar 2001; Uzal, Erdem, Önen ve Gürdal, 2010).

Liselerde fen derslerinin çoğunlukla sunuş yoluyla işlendiği, laboratuvar uygulamalarına çok az yer verildiği söylenebilir. Laboratuvar uygulamalarının genellikle gösteri deneyi şeklinde yürütüldüğü söylenebilir. Çallica vd. (2001) ilköğretim kurumlarındaki laboratuvar kullanımını incelemiştir. Bu çalışma sonucunda öğretmenlerin gerektiği şekilde deney yapamadıkları ortaya konmuştur. Deney yapan öğretmenlerin ise çoğunlukla gösteri deneylerine yer verdiklerini belirtilmiştir. Bu durumun sebebi olarak öğretmenlerin laboratuvar kullanımı konusunda yetersiz olması gösterilebilir. Nitekim Şeker, Yalçın ve Yurdanur Altunay (2006) yaptıkları çalışmada öğretmenlerin laboratuvar uygulamaları konusunda kendilerini yetersiz hissettiklerini ve bu nedenle laboratuvar uygulamalarına ya nadiren yer verdiklerini ya da hiç yer vermediklerini belirlemiştir.

Hizmet öncesi fen öğretmenlerinin çoğunun lise yaşantıları boyunca laboratuvar deneyimi elde edemedikleri söylenebilir. Bunun nedenleri olarak okulda laboratuvar olmaması, var olan laboratuvarların fiziki koşullarının yetersiz olması, laboratuvarın amacı dışında kullanılması, öğretmenlerin laboratuvar kullanımında yetersiz olması gösterilebilir. Elde edilen bu sonuç literatürde yer alan bazı çalışmalarla benzerlik göstermektedir (Alpaut, 1993; Büyük, Demir ve Erol 2010; Ekici, 1996; Gürdal, 1991; Karaca, Uluçınar ve Cansaran, 2006).

Bu çalışmadan elde edilen bulgulara dayalı olarak lise öğreniminde deney yapan öğrencilerin fenden zevk aldıkları ve fene olan meraklarının arttığı söylenebilir. Laboratuvar yaşantısına sahip olmayan öğrencilerin ise laboratuvar uygulamalarında başarısız olma konusunda endişe duydukları ve korktukları söylenebilir. Literatürde yer alan bazı çalışmalar da laboratuvar uygulamalarının fene karşı ilgi ve merakı arttırdığı sonucunu destekler niteliktedir (Güneş vd., 2013; Kaya ve Büyük, 2011). Laboratuvar uygulamalarının öğrencilerin yaparak yaşayarak, birden fazla duyu organına hitap eden, kendi kendilerine keşfetme imkanı buldukları öğrenme ortamları sağlaması buna gerekçe olarak gösterilebilir.

Hizmet öncesi fen öğretmenleri lise öğrenimlerinde yaptıkları deneyleri hatırlamaktadırlar. Buna dayalı olarak laboratuvarların etkili ve kalıcı öğrenmeler sağlayabileceği söylenebilir. Aydoğdu (1999) yaptığı çalışmada laboratuvar uygulamalarının bilgilerin kalıcılığına olumlu katkılar sağladığını belirtmektedir. Bunun sebebi öğrencilerin uygulamaya aktif olarak katılması olabilir. Ayrıca az sayıda yapılan deneyler öğrencilere sıradışı gelmiş bu nedenle de akılda kalmış olabilir.

Hizmet öncesi fen öğretmenlerinin lise öğretmenlerini laboratuvarı kullanma konusunda yetersiz gördükleri söylenebilir. Şeker vd. (2006) yaptıkları çalışmada öğretmenlerin kendilerini laboratuvar uygulamalarında yetersiz gördüklerini belirtmiştir. Öğretmenlerin öğrenimleri boyunca yeterli laboratuvar eğitimi almamaları, hizmet içi eğitimlerin yetersiz olması bunun nedeni olabilir.

ÖNERİLER

Bu çalışmadan elde edilen sonuçlara göre liselerin çoğunda fiziki koşulları yeterli laboratuvarlar bulunmamaktadır. Milli Eğitim Bakanlığı okullarda laboratuvar kurulmasına öncelik vermelidir. Bir semtte laboratuvarı olmayan birden fazla okul bulunuyorsa bu okullar için buldukları çevreye ortak kullanabilecekleri bir laboratuvar yapılabilir. Laboratuvarı bulunmayan okulların belirli günlerde bu ortak laboratuvardan yararlanması sağlanabilir. Deneye dayalı fen öğretimini uygulamaya koymak için yüksek standartlara sahip laboratuvarlar elzem değildir. Basit ve ucuz malzemelerle sınıf ortamında yapılabilecek birçok deney vardır. Basit malzemeler kullanılarak yapılabilen deneyler Milli Eğitim Bakanlığı tarafından bir kitap haline getirilerek öğretmenlerin kullanımına sunulabilir.

Bu çalışmadan elde edilen sonuçlardan bir diğeri de öğretmenlerin laboratuvar kullanımında yetersiz olduklarıdır. Liselerde fen bilimleri, fizik, kimya, biyoloji derslerini öğretmekte olan öğretmenler için laboratuvarların etkili kullanımı konusunda hizmet içi eğitimler tasarlanıp uygulanabilir. Üniversitelerde sürdürülmekte olan laboratuvar uygulamaları hizmet öncesi öğretmenlerin lise öğrenimlerindeki laboratuvar yaşıntılarını tamir edebilecek şekilde yürütülebilir.

KAYNAKLAR

- Alpaut, O. (1993). *Fen eğitiminin verimli ve işlevsel hale getirilmesi*. Ortaöğretim Kurumlarında Fen Öğretimi ve Sorunları Sempozyumu. Ankara: TED.
- Ayas, A. (1998). *Fen bilgisi öğretiminde laboratuvar kullanımı*. Eskişehir: Anadolu Üniversitesi Açıköğretim Fakültesi Yayınları.
- Aydoğdu, C. (1999). Kimya laboratuvar uygulamalarında karşılaşılan güçlüklerin saptanması, *Hacettepe Üniversitesi Eğitim Fakültesi Dergisi*, 15, 30-35.
- Böyük, U., Demir, S. & Erol, M. (2010). Fen ve teknoloji dersi öğretmenlerinin laboratuvar çalışmalarına yönelik yeterlik görüşlerinin farklı değişkenlere göre incelenmesi, *Tubav Bilim Dergisi*, 3(4), 342-349.
- Büyüköztürk, Ş., Kılıç Çakmak, E., Akgün, Ö. E., Karadeniz, Ş. & Demirel, F. (2008). *Bilimsel Araştırma Yöntemleri*. Ankara: PegemA.
- Can, Ş. (2012). Fen bilgisi öğretmen adaylarının laboratuvar uygulamalarına yönelik düşüncelerinin cinsiyet, öğretim türü, sınıf düzeyi ve lise laboratuvar deneyimleri açısından araştırılması, *Türk Fen Eğitimi Dergisi*, 9(1).
- Çallica, H., Erol, M., Sezgin, G., & Kavcar, N. (2001). *İlköğretim kurumlarında laboratuvar kullanımına ilişkin bir çalışma*. IV. Fen Bilimleri Kongresi. Ankara: MEB. Basımevi.
- Ekici, G. (1996). *Biyoloji öğretmenlerinin öğretimde kullandıkları yöntemler ve karşılaştıkları sorunlar*. Yayınlanmamış Yüksek Lisans Tezi, Ankara Üniversitesi Sosyal Bilimler Enstitüsü, Ankara.
- Feyzioğlu, B., Demirdağ, B., Ateş, A., Çobanoğlu, İ., Altun, E. & Akyıldız, M. (2011). *İlköğretim Online*, 10(3), 1208-1226.
- Güneş, M. H., Şener, N., Topal Germi, N. & Can, N. (2013). Fen ve teknoloji dersinde laboratuvar kullanımına yönelik öğretmen ve öğrenci değerlendirmeleri, *Dicle Üniversitesi Ziya Gökalp Eğitim Fakültesi Dergisi*, 20, 1-11.
- Gürdal, A. (1991). İlkokul fen eğitiminde laboratuvar ve araç kullanımı. *Marmara Üniversitesi Eğitim Fakültesi Dergisi*, 3, 145-155.
- Karaca, A., Uluçınar, Ş. & Cansaran, A. (2006). Fen bilgisi eğitiminde laboratuvarla karşılaşılan güçlüklerin saptanması, *Milli Eğitim Dergisi*, 170, 250-259.
- Kaya, H. & Böyük, U. (2011). İlköğretim II. kademe öğrencilerinin fen ve teknoloji dersine ve fen deneylerine karşı tutumları. *TÜBAV Bilim Dergisi*, 4(2), 120-130.
- Kocakülah, A. & Savaş, E. (2011). Fen bilgisi öğretmen adaylarının deney tasarlama ve uygulama sürecine ilişkin görüşleri, *Ondokuz Mayıs Üniversitesi Eğitim Fakültesi Dergisi*, 30(1), 1-28.
- Sürücü, A., Özdemir, H., Bilen, K. & Köse, S. (2013). Fen bilgisi öğretmen adaylarının laboratuvara yönelik tutumları, *International Journal of Social Science*, 6(2), 843-852.
- Şeker, R., Yalçın, M. & Yurdanur Altunay, A. (2006). *Öğrencilerin kullanımına açık merkez fen laboratuvarları kurulması önerisi ile ilgili öğrenci, öğretmen ve veli görüşleri*. VII. Ulusal Fen Bil. Eğit. Kong. Bil. Kitabı. Ankara: M.E.B.

- Taşkın Ekici, F., Ekici, E. & Taşkın, S. (2002). Fen laboratuvarlarının içinde bulunduğu durum. *V. Ulusal Fen Bilimleri ve Matematik Eğitimi Kongresi*, 16-18 Eylül, Ankara.
- Uzal, G., Erdem, A., Önen, F. & Gürdal, A. (2010). Basit araç gereçlerle yapılan fen deneyleri konusunda öğretmen görüşleri ve gerçekleştirilen hizmet içi eğitimin değerlendirilmesi, *Necatibey Eğitim Fakültesi Elektronik Fen ve Matematik Eğitimi Dergisi (EFMED)*, 4(1), 64-84.
- Yeşilyurt, S. (2006). Öğretmen adayları ve öğretim elemanları gözüyle genel biyoloji laboratuvar uygulamalarının değerlendirilmesi, *Kastamonu Eğitim Dergisi*, 14(2), 481-496.
- Yıldırım A. & Şimşek H. (2005). *Sosyal Bilimlerde Nitel Araştırma Yöntemleri*. Ankara: Seçkin Yayınevi.

INVESTIGATING PRE-SERVICE MATHEMATICS TEACHERS' VIEWS ABOUT VECTOR APPROACH TO GEOMETRY AND INSTRUCTIONAL METHODS DURING GEOMETRY TEACHING

Vildan KATMER-BAYRAKLI

Hatice AKKOÇ

Recently, there have been curriculum changes in geometry in Turkey as well as in other countries. The most obvious change in geometry curriculum in Turkey is the introduction of “vector approach”. This study investigates pre-service mathematics teachers’ views about vector approach and instructional methods used by them during geometry teaching. Participants of the study are thirty-seven pre-service mathematics teachers who were at the last year of a teacher preparation program in secondary mathematics teaching during 2011-2012 academic years. At the first phase of the study, questionnaires with open-ended questions were administered to thirty-seven pre-service teachers to reveal their views about vector approach to geometry. Data obtained from questionnaires was analysed using content analysis. At the second phase of the study, four participants were selected using purposive sampling. Instructional methods used by these participants were investigated by analysing their lesson plans, micro-teaching lessons and semi-structured interviews. Data obtained from these sources was analysed using descriptive analysis. Findings from the data indicated that thirty-seven pre-service teachers had both positive and negative views about vector approach. In addition, all four participants used teacher-centred instructional methods during their lessons although they were in favour of vector approach since it prevented rote-learning and it could help students discover concepts for themselves.

Keywords: Geometry teaching, vector approach, pre-service mathematics teachers

ORTAOKUL 7.SINIF ÖĞRENCİLERİNİN UZAY ARAŞTIRMALARI KONUSUNDAKİ ALTERNATİF KAVRAMLARININ BELİRLENMESİ

INVESTIGATION OF SECONDARY SCHOOL 7th GRADE STUDENTS' ALTERNATIVE CONCEPTS ABOUT SPACE RESEARCHES

Elif BÜLBÜL

Fen Bilimleri Öğretmeni, Çatak Yatılı Bölge Ortaokulu, Van, Türkiye
elf_bulbul_ktu@hotmail.com

Çiğdem ŞAHİN

Yrd. Doç. Dr., Giresun Üniversitesi, Eğitim Fakültesi, İlköğretim Bölümü Fen Bilgisi Eğitimi, Giresun, Türkiye,
hcsahin38@gmail.com

Ümmü Gülsüm DURUKAN

Arş. Gör., Giresun Üniversitesi, Eğitim Fakültesi, İlköğretim Bölümü Fen Bilgisi Eğitimi, Giresun, Türkiye,
u.g.durukan@gmail.com

ÖZET: Araştırmanın amacı, ortaokul 7. sınıf öğrencilerinin uzay araştırmaları konusunda sahip oldukları alternatif kavramları kavram karikatürleri ile belirlemektir. Araştırmanın örneklemini 2012-2013 eğitim öğretim yılında güz dönemi, Van'ın bir ilçesinde yatılı bölge ortaokulunda 7.sınıfta öğrenim gören 53 ortaokul öğrencisi oluşturmaktadır. Özel durum metodunun kullanıldığı bu çalışmada, veri toplama aracı olarak “Uzay Araştırmaları” konusu ile ilgili 11 kavram karikatürü hazırlanmış ve kullanılmıştır. Kavram karikatürleri hazırlanırken ortaokul 7. sınıf fen bilimleri dersi öğretim programındaki kazanımlarından ve literatürde belirlenen alternatif kavramlardan yararlanılmıştır. Kavram karikatürlerinin geçerliliği için 5 alan eğitimi uzmanının görüşleri alınmış ve kavram karikatürlerinin pilot uygulaması yapılmıştır. Elde edilen veriler betimsel olarak analiz edilmiştir. Öğrenci cevapları kategorileştirilmiş ve cevapların ifade edilme sıklıkları hesaplanmıştır. Araştırmada, ortaokul 7. sınıf öğrencilerinin “Uzay Araştırmaları” konusunda birçok alternatif kavramlara sahip oldukları tespit edilmiştir.

Anahtar sözcükler: Alternatif kavram, kavram karikatürleri, ortaokul 7. sınıf öğrencileri, uzay araştırmaları.

ABSTRACT: The purpose of this study was to determine the alternative concepts of the secondary school 7th grade students about space researches by concept cartoons. The sample of this study composed of 53 secondary school 7th grade students who study in a town of Van set in 2012-2013 academic years- fall term. At this study which was used case study method, 11 concept cartoons that are related to space researches were prepared and used as data collection tool. While concept cartoons are prepared, were used from acquisitions of secondary school 7th grade science lesson and alternative concepts were examined in the literature. For the validity of concept cartoons, 5 field education experts' views were taken and the pilot implementation of concept cartoons was done. The data obtained were analyzed descriptively. Students' answers were categorized and the sequence of finding voice in answers was calculated. It is determined that secondary school 7th grade students have many alternative concepts about “space researches” in this study.

Key words: Alternative concept, concept cartoons, secondary school 7th grade students, space researches.

GİRİŞ

Fen bilimleri öğretim programının temelini oluşturan yapılandırmacı öğrenme yaklaşımı, öğrenenlerin bilgi edinmeye başlarken boş bir zihinle başlamadığını, yeni öğrendiği konu veya kavramla ilişkili ön bilgilerini harekete geçirdiğini ve öğrendiği yeni bilgiyi etkin olarak zihninde kendisinin yapılandığını vurgular. Bu bağlamda öğrenmenin gerçekleşebilmesi ve öğrenme ortamlarındaki yeni bilgilerin sağlam temeller üzerine yapılandırılmasında öğrenenlerin bilişsel yapılarında yer alan mevcut kavramların tespit edilmesi önemlidir. Öğrenciler yeni öğrenecekleri bilgileri eski bilgileriyle ilişkilendirerek anlamlandırır ve zihinlerinde yapılandırır (Osborne & Wittrock, 1983). Bu nedenle, öğrencilerin öğrendikleri konu hakkındaki ön bilgilerinde herhangi bir eksiklik bulunursa bu durum yanlış anlamalara ve bilimsel gerçeklere uymayan

bilgilerin ortaya çıkmasına neden olmaktadır (Hewson & Hewson, 1984). Bunun yanında, bazı fen kavramlarının soyut olması, öğrenciler tarafından zor anlaşılmasına ve ezberlenerek bilimsel anlamlarından uzak bir şekilde öğrenilmesine yol açmaktadır. Bilimsel gerçeklerle uyuşmayan fikirler literatürde çoğunlukla alternatif kavram olarak isimlendirilmektedir. Alternatif kavram bir kişinin bir kavramı anladığı şeklin, uluslararası platformda ortaklaşa kabul edilen bilimsel anlamından önemli derecede farklılık göstermesi olarak tanımlanmaktadır (Stepans, 1996). Alternatif kavramlar öğrenmeyi olumsuz olarak etkilemekte ve değişime karşı da oldukça direnç göstermektedirler (Aypay, Erdoğan & Sözer, 2007). Literatürde kuvvet ve hareket (Gamble, 1989), ışık (Heywood, 2005) ve çeşitli astronomi (Emrahoğlu & Öztürk, 2009; Trumper, 2003) konu ve kavramları hakkında yapılan çalışmalarda çeşitli alternatif kavramlar tespit edilmiştir.

Literatürde astronomi hakkında yapılan araştırmalar incelendiğinde, bu araştırmaların daha çok Dünya (İbret & Aydınöz, 2011; İyibil, 2010; Kikas, 2005), Ay ve evreleri (Trundle, Atwood & Christopher, 2007), yıldızlar ve özellikleri (Agan, 2004; Ekiz & Akbaş, 2005; Emrahoğlu & Öztürk, 2009; İyibil, 2010; Kurnaz, 2012), Güneş (İyibil, 2010; Kikas, 2005; Kurnaz & Değirmenci, 2011), uydular (İyibil, 2010; Kurnaz & Değirmenci, 2011), kuyruklu yıldız (Kurnaz, 2012; Taşcan, 2013), takımyıldızı (Kurnaz, 2012), evren (Ekiz & Akbaş, 2005; Emrahoğlu & Öztürk, 2009), Güneş Sistemi (Cin, 2007), gökyüzü (Kikas, 2005), yörünge (Ekiz & Akbaş, 2005) konu ve kavramları ile ilgili olduğu görülmüştür. Ancak literatürde öğrencilerin uzay araştırmaları ile ilgili alternatif kavramlarının belirlenmesine yönelik bir araştırmaya ise rastlanılmamıştır. Öğrencilerin uzay araştırmaları ile ilgili çalışmalara ilgili duymaları ve bu konuyu verimli bir şekilde öğrenebilmeleri için öncelikle öğrencilerin uzay araştırmaları konusundaki ön bilgilerinin ve alternatif kavramlarının tespit edilmesi de oldukça önemlidir.

Öğrencilerin kendi anlamalarını ve ilgili kavram hakkındaki alternatif kavramlarını sorgulamalarında ve düşüncelerinin gerekçelerini rahat bir şekilde ifade edebilmelerinde kavram karikatürleri oldukça etkilidir (Keogh & Naylor, 1999; Stephenson & Warwick, 2002). Çünkü kavram karikatürlerinde karmaşık ve soyut olan fen kavramları basit bir şekilde çizgi karakterlerle ifade edilebilmektedir. Kavram karikatürleri ile öğrencilerin daha önce hiç farkına varmadıkları bir olayla karşı karşıya gelmeleri sağlanarak öğrencilerin ön bilgilerinden gözden geçirmelerine imkan sunulabilmektedir (Stephenson & Warwick, 2002).

Bu araştırmanın amacı ortaokul 7. sınıf öğrencilerin uzay araştırmaları konusunda sahip oldukları alternatif kavramları kavram karikatürleri ile belirlemektir.

YÖNTEM



Araştırma ortaokul 7. sınıf öğrencilerinin “Uzay Araştırmaları” konusundaki ön bilgilerinin ve alternatif kavramlarını tespit etmek için tasarlandığından özel durum metoduna göre yürütülmüştür. Özel durum çalışmaları bir olayı derinlemesine incelemeye imkân sağlayan bir yöntemdir.

Evren ve Örneklem

Araştırmanın evrenini, 2012–2013 eğitim öğretim yılı güz döneminde Van ilinde öğrenim gören tüm 7. sınıf öğrencileri oluşturmaktadır. Araştırmanın örneklemini, 2012–2013 eğitim öğretim yılı bahar döneminde Van’ın bir ilçesinde yatılı bölge ortaokulunda 7.sınıfta öğrenim gören 53 ortaokul öğrencisi oluşturmaktadır.

Veri Toplama Aracı

Veri toplama aracı olarak, “Uzay Araştırmaları” konusuyla ilgili 11 farklı kavram karikatüründen oluşan ‘Kavram Karikatürü Testi (KKT)’ hazırlanmıştır. KKT hazırlanırken araştırmacılar tarafından ortaokul 7. Sınıf fen bilimleri dersi öğretim programındaki ilgili kazanımlar incelenmiştir. Ayrıca, kavram karikatürleri hazırlanırken literatürde yapılan çalışmalarda tespit edilen alternatif kavramlardan da yararlanılmıştır. KKT’nin yapı geçerliğini sağlamak amacıyla 5 alan eğitimi uzmanının görüşleri alınmıştır. Ayrıca KKT’nin pilot uygulaması da yapılmıştır. Aşağıda KKT’de uzay kirliliği ile ilgili bir kavram karikatürüne Şekil 1’de yer verilmiştir.

<p>Uzay kirliliğine uzaya yayılan roket parçaları, uzay istasyonlarının atıkları ve işlevini yitirmiş yapay uydular neden olabilir.</p>	 <p>Erdi</p>	<p>Sizce hangi öğrenci veya öğrenciler doğru söylüyor? Nedeniyle birlikte açıklayınız.</p>
<p>Arkadaşlar uzay kirliliği diye bir şey yoktur. Çünkü uzay uçsuz bucaksızdır, kirlenemez.</p>	 <p>Esra</p>	<p>Eğer bu öğrencilerden farklı bir düşünceye sahipseniz düşüncenizi siz karakterinin düşünce baloncuğuna yazınız.</p>
<p>Dünyadaki çöplerin uzaya gönderilmesiyle uzay kirliliğinin ortaya çıktığını düşünüyorum.</p>	 <p>Rumeysa</p>	<p>Siz</p>

Şekil 1. KKT’de yer alan bir kavram karikatürü örneği

Veri Analizi

KKT’den elde edilen veriler, betimsel olarak analiz edilmiştir. Öğrencilerin her bir kavram karikatürüne verdikleri cevaplar kategorileştirilerek “bilimsel açıklamalar” ve “bilimsel olmayan açıklamalar” temaları altında; “gök biliminin amacı, gök bilimci, teleskop, uzay kirliliği astronot ve teknoloji-uzay araştırması ilişkisi” alt temaları oluşturulmuştur. Araştırmacılar temalarla ilgili fikir birliğine vararak verilerin geçerliğini sağlamışlardır. Her bir tema ile ilgili olarak bilimsel açıklamaların ve bilimsel olmayan alternatif kavram içeren açıklamaların ifade edilme sıklıkları ve yüzdelik hesapları yapılmıştır. Ayrıca, verilerin analizinde kavram karikatüründeki ifadelerden farklı alternatif kavramlara sahip olan öğrencilerin “siz” karakterinin düşünce baloncuğunda belirttikleri ifadeleri de ilgili temalar altında sunulmuştur.

BULGULAR

Ortaokul 7. sınıf öğrencilerinin “Uzay Araştırmaları” konusunda sahip oldukları bilimsel olan ve bilimsel olmayan düşünceleri (alternatif kavramları) Tablo 1’de sunulmuştur:

Tablo 1 incelendiğinde öğrencilerin 22 tane alternatif kavrama sahip oldukları görülmektedir. Öğrencilerin seçtikleri karikatür karakterlerin ifadeleri gök bilimi, gök bilimci, teleskop, uzay kirliliği, astronot ve teleskop kavramları ile ilişkilendirilmiş ve kategorileştirilerek ifade edilme sıklığı ve yüzde değerleri hesaplanmıştır.

Elde edilen bulgulara göre ortaokul 7. sınıf öğrencilerinin “Uzay Araştırmaları” konusunda gök bilimi kodunda en fazla sahip oldukları alternatif kavramın “*Eski medeniyetlerde yapılan gökyüzü gözlemleri bilimsel amaçlıydı.*”, gök bilimci kodunda en fazla sahip oldukları alternatif kavramın “*Gök bilimcilerinin diğer adı astronottur.*”, teleskop kodunda en fazla sahip oldukları alternatif kavramın “*Sanırım teleskopların oküler kısmında kalın kenarlı, objektif kısmında ise ince kenarlı mercek kullanılır.*”, uzay kirliliği kodunda en fazla sahip oldukları alternatif kavramın “*Uzay kirliliği diye bir şey yoktur. Çünkü uzay uçsuz bucaksızdır, kirlenemez.*”, astronot kodunda en fazla sahip oldukları alternatif kavramın “*Astronotlar astronomi üzerine uzayda çalışma yapan bilim insanlarıdır.*” ve teknoloji kodunda en fazla sahip oldukları alternatif kavramın ise “*Teflon, tükenmez kalem, alüminyum folyo uzay çalışmalarıyla üretilmiş olamaz. Çünkü uzay çalışmaları için geliştirilen teknolojilerin günlük yaşamımızla bağlantısı yoktur. Örneğin uzay sondalarını günlük hayatımızda kullanmıyoruz.*” şeklinde olduğu belirlenmiştir.

Tablo 1. Öğrencilerin KKT'deki Kavram Karikatürlerine Verdikleri Cevaplardan Elde Edilen Bulgular

Uzay Araşt. ile İlgili Tema	Bilimsel Açıklamalar		Bilimsel Olmayan Açıklamalar			
	Öğrencilerin Seçtikleri Karikatür Karakterlerin İfadeleri	f	%	Öğrencilerin Seçtikleri Karikatür Karakterlerin İfadeleri	f	%
Gök Biliminin Amacı	Eski medeniyetlerde yaşayan insanların gökyüzünü inceleme amaçları zamanı belirlemektir.	15	28	Eski medeniyetlerde yapılan gökyüzü gözlemleri bilimsel amaçlıydı.	22	42
	Gök bilimciler, gök cisimlerinin hareketlerini ve yapısını teleskop gibi araçlarla inceleyen kişilerdir.	16	30	Sanırım eski medeniyetlerde yaşayan insanların gökyüzünü inceleme amaçları gelir elde etmektir.	16	30
Gök Bilimci	Ünlü Türk gök bilimcilerinden biri de Takıyüddin'dir. Gözlemlerde kullanmak için yıldızların yüksekliğini ve açıklığını ölçen alet gibi birçok alet tasarlamıştır.	14	26	Sanırım gök cisimlerinin hareketlerini ve yapısını teleskop yardımıyla inceleyen kişiler kozmonottur.	12	23
	Gökyüzü ve uzaydaki gök cisimlerinin hareketlerini ve yapısını incelemek için kullanılan araçlara teleskop denir.	23	43	Gök bilimcilerinin diğer adı astronottur.	27	51
Teleskop	Teleskopların oküler ve objektif kısımlarında da ince kenarlı mercek kullanılır. Ayrıca görüntü netliğini sağlamak için iç içe geçmiş kartonlar kullanılmalıdır.	16	30	Ünlü Türk gök bilimcilerinden biri Biruni'dir. Biruni Güneş'i gözlemek için teleskop tasarlamıştır.	13	25
	Uzay kirliliğine uzaya yayılan roket parçaları, uzay istasyonlarının atıkları ve işlevini yitirmiş yapay uydular neden olabilir.	13	25	Ali Kuşçu ünlü Türk gök bilimcilerinden biridir ve Güneş'in ilk haritasını çıkaran bilim adamıdır.	25	47
Uzay Kirliliği	Astronotlar uzayda fizik, kimya, biyoloji gibi birçok alanda inceleme yapar	9	17	Sanırım teleskop ile sadece gökyüzündeki gök cisimlerinin hareketlerini ve yapısını incelenir.	15	28
	Teknolojinin gelişmesiyle birlikte uzay araştırmaları hız kazanmıştır ve yapılan uzay çalışmaları sırasında teflon, tükenmez kalem, alüminyum folyo gibi ürünler üretilmiştir.	12	23	Bence gökyüzündeki ve uzaydaki gök cisimlerinin hareketlerini ve yapısını incelemede mikroskop adı verilen araç kullanılır.	17	32
Astronot	1969 yılında Neil Armstrong, Adwin Aldrin ve Michel Collins adlı üç astronot Ay'a ayak basarak diğer gezegenlere yapılması düşünülen araştırmaları hızlandırmıştır.	16	30	Kalın kenarlı mercekle basit bir teleskop yapılabilir .Oküler kısmında ve objektif kısmında kalın kenarlı mercek kullanılır.	16	30
	Uzayda yapılan çalışmalar ile yeni gezegenler, yıldızlar, galaksiler bulunmaktadır. Bu da bize evrenin uçsuz bucaksız olduğunu göstermektedir.	22	42	Teleskopların oküler kısmında kalın kenarlı, objektif kısmında ise ince kenarlı mercek kullanılır.	18	34
Teknoloji-Uzay Araştırması İlişkisi	Uzay araştırmaları sayesinde gelecekte insanlar Dünya'dan başka gezegenlerde şehirler kurarak buralarda yaşamlarını sürdürebileceklerdir.	19	36	Uzay kirliliği diye bir şey yoktur. Çünkü uzay uçsuz bucaksızdır, kirlenemez.	22	42
				Dünyadaki çöplerin uzaya gönderilmesiyle uzay kirliliğinin ortaya çıktığını düşünüyorum.	16	30
				Astronotlar sadece uzayda yaşam olup olmadığı hakkında araştırma yapar. Örneğin Astronotlar Mars'ta yaşam olup olmadığını araştırmışlardır.	18	34
				Astronotlar astronomi üzerine uzayda çalışma yapan bilim insanlarıdır.	22	42
				Bence, teknolojinin gelişmesiyle uzay araştırmaları hız kazanmıştır. Örneğin Dünya'ya yakın ve üzerinde yaşam olabileceği düşünülen Mars gezegenine insansız uzay araçları gönderilerek gezegenin yapısı hakkında bilgi elde edilmektedir. Fakat uzay araştırmalarının teknolojiye katkısı yoktur.	16	30
				Teflon, tükenmez kalem, alüminyum folyo uzay çalışmalarıyla üretilmiş olamaz. Çünkü uzay çalışmaları için geliştirilen teknolojilerin günlük yaşamımızla bağlantısı yoktur. Örneğin uzay sondalarını günlük hayatımızda kullanmıyoruz.	25	47
				Ay'a atılan ilk adım sayesinde ulaşılan bilgiler uzay araştırmaları için yeterli olmuştur.	21	40
				Sanırım Ay'a atılan ilk adımla uzay araştırmaları hızlanmamıştır. Uzay araştırmaları teleskopun icadı ile hızlanmıştır.	11	21
				Gelişen teknoloji sayesinde uzaya, uzay sondaları, uzay mekikleri ve yapay uydular gönderilmektedir. Böylece uzay hakkında sürekli yeni bilgiler elde ediliyor. Örneğin Plüton 2006 yılına kadar gezegen olarak kabul edilirken artık cüce gezegen sınıfına dahil edilmiştir.	10	19
				Sanırım uzay hakkında yapılan çalışmalarda en son noktaya gelinmiştir. Daha fazla bilgiye ulaşılamaz.	18	34
				Uzay araştırmaları sayesinde gelecekte gezegenlerin sıcaklıklarını Güneş'e uzaklıklarıyla ilişkilendirmek mümkün olacaktır.	20	38
				Uzay araştırmaları sayesinde gelecekte uzaya yapay uydular gönderilerek haberleşme imkanı sağlanabilecektir.	11	21

TARTIŞMA, SONUÇ VE ÖNERİLER

Son yıllarda yapılandırmacı öğrenme yaklaşımının etkisiyle Fen Bilimleri Dersi Öğretim Programında, öğrencilerin süreç içerisinde izlenmesi, yönlendirilmesi, öğrenme güçlüklerinin belirlenerek giderilmesi, anlamlı ve kalıcı öğrenmenin sağlanmasında geleneksel metotlar yerini bazı alternatif metotlara bırakmıştır (Şenel-Çoruhlu, 2013). Yapılandırmacı öğrenme yaklaşımına paralel olarak; öğrencilerin öğrenme durumunun, belirlenmesine, izlenmesine ve değerlendirilmesine yönelik elde edilen sayısal değerlerin anlam kazanabilmesi, öğrencinin gelişiminin izlenmesi ve bu gelişime bağlı olarak öğrencinin yönlendirilmesi için alternatif ölçme ve değerlendirme yöntem ve tekniklerinin kullanılması da oldukça önemlidir (TTK, 2013). Alternatif ölçme ve değerlendirme araçlarından birisi de kavram karikatürleridir. Bu çalışmada da öğrencilerin uzay araştırmaları konusundaki öğrenme durumları kavram karikatürleri ile ortaya konulmuştur. Araştırmada öğrencilerin;

- Eski medeniyetlerinde gök biliminin amaçları ile ilgili alternatif kavramlara sahip oldukları,
 - Gök bilimci ile astronot kavram karmaşası yaşadıkları,
 - Uzay araştırmaları ile ilgili araştırma yapan gök bilimcilerinin çalışmalarını karıştırdıkları,
 - Teleskopun kullanım amacını bilmedikleri, teleskopu mikroskopla karıştırdıkları ve teleskopun yapısını bilmedikleri,
 - Teknoloji ile uzay araştırmaları arasında ilişki kuramadıkları
- sonucuna ulaşılmıştır. Benzer şekilde Şenel-Çoruhlu'nun (2013) çalışmasında da ortaokul 7. sınıf öğrencilerinin astronot ve gökbilimci kavramlarını karıştırdıkları belirlenmiştir.

Elde edilen bulgulara göre öğrencilerin bilişsel yapılarında “Uzay Araştırmaları” konusuyla ilgili alternatif kavramların olduğu tespit edilmiştir. Öğrencilerin anlamlı öğrenmeler gerçekleştirebilmeleri için alternatif kavramlarının belirlenmesinin gerekli olduğu düşünülmektedir. Çünkü öğrencilerin sahip oldukları bu ön bilgiler/alternatif kavramlar kabul edilen bilimsel teorilerden uzak ve öğretime karşı dirençlidirler. Nitekim öğrenciler yeni kazandıkları bilgileri sahip oldukları bu ön bilgiler/alternatif kavramlar üzerine inşa etmektedirler. Buna paralel olarak da öğrencilerin sahip oldukları ön bilgiler hatalı ise onlar üzerine inşa edilen bilgilerin de hatalı olması muhtemeldir. Bu nedenle elde edilen sonuçlar ışığında, öğrencilerde “Uzay Araştırmaları” konusunda tespit edilen alternatif kavramların öğrencilere zengin bir öğrenme ortamı sağlanarak giderilmesine yönelik araştırmaların yapılması önerilmektedir.

KAYNAKLAR

- Agan, L. (2004). Stellar Ideas: Exploring Students' Understanding of Stars, *Astronomy Education Review*, 3(1), 77-97.
- Aypay, A., Erdoğan, M. & Sözer, M.A. (2007). Variation among schools on classroom practices in science based on TIMSS-1999 in Turkey. *Journal of Research in Science Teaching*, 44, 10, 1417-1435.
- Cin, M., (2007). Alternative Views of the Solar System Among Turkish Students , *Review of Education*, 53, 39-53
- Ekiz, D. & Akbaş, Y. (2005). İlköğretim 6. sınıf öğrencilerinin astronomi ile ilgili kavramları anlama düzeyi ve kavram yanlışları, *Milli Eğitim Dergisi*, 165, 61-78.
- Emrahoğlu, N. & Öztürk, A. (2009). Fen bilgisi öğretmen adaylarının astronomi kavramlarını anlama seviyelerinin ve kavram yanlışlarının incelenmesi üzerine boylamsal bir araştırma. *Ç.Ü. Sosyal Bilimler Enstitüsü Dergisi*, 18 (1), 165-180.
- Gamble R. (1989). Force. *Physic Educ*, 24:79-82.
- Heywood DS. (2005). Primary trainee teachers' learning and teaching about light: some pedagogic implications for initial teacher training. *Int J Sci Educ*27:1447-1475.
- Hewson, P. W. & Hewson, M. G. (1984). The Role of Conceptual Conflict in Conceptual Change and the Design of Science Instruction, *Instructional Science*, 13, 1-13.
- İbret, B. Ü. & Aydınözü, D. (2011). İlköğretim II. kademe öğrencilerinin “dünya” kavramına ilişkin geliştirdikleri metaforlar. *Kastamonu Eğitim Dergisi*, 19 (1), 85-102.
- İyibil, Ü.G. (2010). *Farklı programlarda öğrenim gören öğretmen adaylarının temel astronomi kavramlarını anlama düzeylerinin ve ilgili kavramlara ait zihinsel modellerinin analizi*. Yüksek Lisans Tezi, Karadeniz Teknik Üniversitesi, Fen Bilimleri Enstitüsü, Trabzon.
- Keogh, B. & Naylor, S. (1999). Concept cartoons, teaching and learning in science: an evaluation, *INT. J. SCI. EDUC.*, 21(4), 431- 446.
- Kikas, E. (2005). Development of children's knowledge: the sky, the earth and the sun in children's explanations, *Electronic Journal of Folklore*, 31, 31- 56.

- Kurnaz, M.A. & Değermenci, A. (2011). Temel astronomi kavramlarına ilişkin öğrenci algılamalarının sınıf seviyelerine göre karşılaştırılması. *Mehmet Akif Ersoy Üniversitesi Eğitim Fakültesi Dergisi*, 22, 97-120.
- Kurnaz, M.A. (2012). Yıldız, kuyruklu yıldız ve takımyıldız kavramlarıyla ilgili öğrenci algılamalarının belirlenmesi. *Abant İzzet Baysal Üniversitesi Eğitim Fakültesi Dergisi*, 12 (1), 251-264.
- Osborne, R.J. & Wittrock, M.C. (1983). Learning science: a generative process. *Science Education*, 67 (4): 489-508.
- Stepans, J. (1996). Targeting Students' Science Misconceptions: Physical Science Concepts Using the Conceptual Change Model. *Riverview, Fla. : Idea Factory*.
- Stephenson, P. & Warwick, P. (2002). Using Concept Cartoons to Support Progression in Students' Understanding of Light. *Physics Education*, 37(2), 135-141.
- Şenel Çoruhlu, T. (2013). "Güneş Sistemi ve Ötesi Uzay Bilmecesi" ünitesinde zenginleştirilmiş 5E öğretim modeline göre geliştirilen rehber materyallerin etkililiğinin belirlenmesi. Yayımlanmamış Doktora Tezi, KTÜ, Fen Bilimleri Enstitüsü, Trabzon.
- Taşcan, M. (2013). *Fen bilgisi öğretmenlerinin temel astronomi konularındaki bilgi düzeylerinin belirlenmesi (Malatya ili örneği)*. Yüksek Lisans Tezi, İnönü Üniversitesi, Eğitim Bilimleri Enstitüsü, Malatya.
- Trumper, R. (2003). The need for change in elementary school teacher training-a cross-college age study of future teachers' conceptions of basic astronomy concepts. *Teaching and Teacher Education*, 19, 309-323.
- Trundle, K.C., Atwood, R.K. & Christopher, J.E. (2007). A longitudinal study of conceptual change: preservice elementary teachers' conceptions of moon phases. *Journal of Research in Science Teaching*, 44(2), 303-326.
- TTKB (2013). *Ortaöğretim astronomi ve uzay bilimleri dersi öğretim programı*. Milli Eğitim Bakanlığı, Ankara.

SAMPLE VISUAL ARTS ACTIVITIES INTEGRATED INTO PROBLEM BASED LEARNING METHOD IN SCIENCE COURSES

Sevinç KAÇAR

Department of Science and Technology Education, Dokuz Eylül University,
Institute of Educational Sciences(Turkey)
kacarsevinc@gmail.com

Zeliha YAYLA

Department of Science and Technology Education, Dokuz Eylül University,
Buca Faculty of Education (Turkey)
zeliha.yayla@deu.edu.tr

ABSTRACT: The arrangement of science education program based on the constructivist approach methods and techniques enable students to be active constructors of knowledge. Problem-based learning (PBL) is one of these methods in which students develop a solving method about the problem by using the knowledge they gained from cooperative environments and as a result of their surveys. In this method students participate actively by solving a problem situation given to them during two or three sessions. Supporting PBL with different learning techniques to make PBL sessions and PBL activities more effective might increase students' motivation. Students' active participation is necessary for an effective PBL. It is thought that visual arts activities depict opinions on an event. It is thought that this method which requires students to be active and responsible for their own learning in the learning process may be more effective on the primary school students when it is used with the visual arts according to interdisciplinary understanding in teaching of science.

In this study the use visual arts activities integrated into problem based learning method are explained and sample activities particulate nature of matter unit given. In this activities, real-life problem situations which can be explained by integrating art with science are discussed through problem-based learning scenarios. Art events in scenarios related to the problem situation are integrated with science subjects.

Key words: Science Courses, Problem Based Learning, Visual Arts

IS PREZI MORE USEFULNESS EDUCATION TOOL THAN POWERPOINT?

Andreja ŠPERNJAK

Faculty of Natural Science and Mathematics, University of Maribor, Slovenia

andreja.spernjak@uni-mb.si

ABSTRACT: Using presentation software to support lectures and presentations has become ubiquitous in the whole vertical of education. The most applied presentation in our area is PowerPoint, but Prezi made a free-flowing presentation to give the effect of zooming. The Prezi application is combining creative thinking with facilities of modern technology, which leads to an interactive and highly customised presentation, structured approximately like a mind map. For education purposes, Prezi presentations are available free of charge. However, in our area, only a few students and teachers use Prezi presentation. They do not use it because they are familiar with PowerPoint presentation or they do not know the Prezi presentation.

Some significant differences in learning outcomes, self-efficacy, cognitive load and motivational variables between PowerPoint and Prezi presentation are presented in this paper. This paper also shows advantages and disadvantages of Prezi and PowerPoint presentations.

Key words: Concept map, Education, PowerPoint, Presentations, Prezi

INTRODUCTION

Multimedia materials are frequently used for learning and teaching in 21st century classrooms. With the use of technological tools particularly such as projector, presentation, video and Internet in education in the recent years, visual education has become popular (Vecdi Can et al., 2012). A computer-aided presentation, defined as PowerPoint, is a method of display that supports lecturing (Sugahara & Boland, 2006). PowerPoint presentations were brought to the classroom environment at every stage of education and instruction from the elementary education to graduate education and the lessons gained an interactive structure. A defining attribute of PowerPoint and like different software packages (e.g., Xerte, Apple Keynote, VoiceThread, Libre Office Impress, Google Docs, SlideRocket or Prezi) is the slide show metaphor that undergirds its design and operation. The metaphor of a “virtual slide projector” is clearly visible in the use of today’s PowerPoint software. The program allows the user to design and layout content within the boundaries of individual slides, arrange these slides in the desired order, and then display each slide in sequence to an audience during a live presentation. The slide show metaphor that underlies the use of PowerPoint is itself neither good nor bad, but it does have certain characteristics that a knowledgeable information designer should understand. Prezi, on the other hand, is a relative newcomer (it was released to the public in April, 2009) to the presentation software scene and is unique in its rejection of the slide show metaphor in favor of the “infinite canvas” and zooming user interface. Prezi is certainly not the first computer software to employ the infinite canvas or the zooming user interface but it is the first in the category of presentation software to make use of these metaphors. Instead of a series of slides upon which content is laid out, Prezi offers the presentation designer an “infinite canvas,” a virtually endless two-dimensional space navigated by a zooming user interface. Visual aids (e.g., words, pictures, YouTube video clips) can be arranged anywhere on the canvas in practically any size, orientation, or spatial arrangement imaginable. The zooming user interface makes use of a simultaneous “pan and zoom” effect along a third dimension (the z axis), creating a sense of movement as the presenter moves across the canvas during his presentation (Bean, 2012). Prezi is an interesting alternative to the PowerPoint presentation with introduces an innovative style.

Advantages and disadvantages of PowerPoint in Prezi presentations

The effectiveness of lectures with presentation may depend on the design of presentations slides as well as tasks and individual differences. Beside individual lecture differences programs also have different possibility of use and their own unique characteristics. There are many useful categories with which these characteristic can be explored. With the Venn’s diagram are represented advantages of PowerPoint and Prezi presentation (Table 1) and in Table 2 are represented disadvantages of PowerPoint and Prezi presentation.

Table 1. Venn's Diagram of Advantages of PowerPoint and Prezi Presentation

PowerPoint	Common characteristics	Prezi
<ul style="list-style-type: none"> - most well-known presentation making program - allows the fast data transfer to the other Microsoft Office applications - offers the possibility to compress audio and video clips - Microsoft PowerPoint Mobile allows presentations to be viewed on telephone, as well - limitlessly time of auto-play a single animation or slide - elements can be made to appear immediately as if rendered from thin air, or to "fly in" using various types of computer animation and different speeds of movement 	<ul style="list-style-type: none"> - user-friendly interface - easy to use - allows introducing various graphical elements by using the drawing bar, images in clipart format, pictures, effects on text and imagines, music files and videos - allows presentations for offline use - user has a series of tutorial movies available and the online manual to learn how to use the application - allows presentations between slides - ability for a presenter to display a slide with "hidden" elements 	<ul style="list-style-type: none"> - application is free of charge - it can be made by creating a simple user account (it is accessible) - provides the opportunity to create spectacular presentation - presentation is dynamic and attractive - has an attractive aspect - zooming user interface - able to create mind-map - values the ideas and stimulates the creativity of the one preparing it - helps delivering a more fluent demonstration - able to place the visual elements of the presentation in the most sensible location - presentation designer is free to use position and proximity to visually explain the physical, logical and hierarchical relationships among elements - does not require an external software, since all commands are available in the application interface - there is a total storage space of 100 MB - besides adding text and frames, the creator can draw freely, draw lines or arrows or highlight already pre-existing testes - possibility to use a site paying account, where the offer for making the presentations is diversified and improved - Prezi site has an already made presentation library where we can learn from and choose the most innovative examples

A PowerPoint presentation is a complex mixture of text, graphics, explanations, advanced software and real-time interaction with the audience. Traditional presentation software like PowerPoint is requires preparing a linear story line using a storyboard approach (Figure 1). Prezi allows for both a linear and a free-flowing presentation of a story line (Figure 2).



Figure 1. Linear Sequence of PowerPoint Presentation.

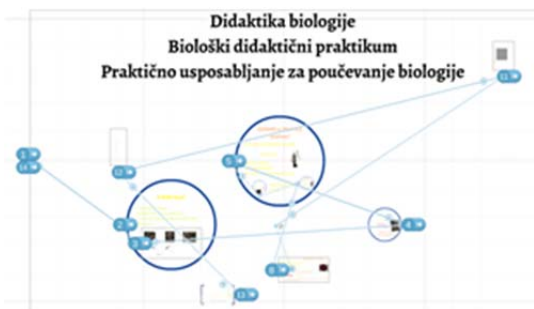

Figure 2. Free-flowing Prezi Presentation

Table 2. Disadvantages of PowerPoint and Prezi Presentation

PowerPoint	Prezi
<ul style="list-style-type: none"> - slides are static, linear (Fig. 2) - more difficult to visually encode the physical or logical relationship among elements of a presentation when those elements are separated by strong display boundaries - lack of diversity - requires the installation of the entire Microsoft Office Pack - compatibility problems may appear between versions - the fonts must be available and various problems may occur with the video files - it does not offer the possibility of simultaneously having a document edited by several users - it requires resizing the pictures at an optimal resolution or the final presentation size in Mbits will be large - effect combinations are difficult to apply 	<ul style="list-style-type: none"> - many of previously presented strengths are only available in the paid account version - requires the existence of an internet connection and the creation of a user account on the Prezi.com website - at less high-performance computers, the frame movement during the presentation may be fragmented - desktop version has several disadvantages: only available for a fee; PDF files cannot be inserted; the application can be used on 3 computers with one license; the more complicated graphs must be made by using a specialized software; the limit per inserted file is 50 MB; files can be inserted, regardless of their size; - the forms can overload the presentation content - due to the over-mobility, imagines can create visual discomfort - limited and fixed time of auto-play a single animation or slide (just 4, 10 or 20 seconds)

Relationship between presentations and degree of learning outcomes, self-efficacy, cognitive load and motivational variables

Concept mapping technique, as a valuable instrument in science teaching, has been organized as a useful tool in assessing students' knowledge structure about a certain topic (Zelev & Lenaerts, 2004). Concept mapping is an effective teaching and learning strategy for both instructors and students to visually examine what students have learned. Through the mapping process, learners may examine their own existing knowledge and learn how to think in more critical and complex ways rather than only in a linear manner (Gul & Boman, 2006). The visualizations would affect the shaping of knowledge in a positive way (Kress et al., 2010). Especially science teachers should therefore use graphics organizers in presentations during which they display the explicit structure of the information (Casteleyn & Mottart, 2012). Prezi encourages using graphic organizers (concept maps, mind mapping, Figure 1) and these could be an alternative to the linear sequencing in most presentation, like PowerPoint is.

Prezi is also a window of opportunity to revitalize the interest in graphic organizers, which are not frequently implemented in classrooms (Kinchin, 2001) but those are very effective in teaching and learning process. When concept maps are applied in the design of e-learning materials, it can foster learning performance and computer self-efficacy (Shaw, 2010).

Many studies have examined the effect of PowerPoint on motivation, self-efficacy and the academic successes of students, and many studies have compared PowerPoint with traditional classes but a few studies were compared the same characteristic between PowerPoint and Prezi presentation. Accordingly to Casteleyn & Mottart (2012) research there is no clear indication that graphic organizers (Prezi) as delivered via presentation software (PowerPoint) can positively affect learning outcomes, self-literacy, perceived mental effort and appreciation of the learning material. Johnson & Christensen (2011) retrieved a similar result when they compared simplified, visually rich slides to more traditional presentation slides. On the other hand, evidence-based literature about graphic organizers has demonstrated its positive impact on learning when students are asked to construct them (Ballentine, 2012).

In this paper are presented characteristics of Prezi and PowerPoint presentations, some significant differences in learning outcomes, self-efficacy, cognitive load and motivational variables between PowerPoint and Prezi presentation. Finally in the paper are represented to survey biology students' opinions on and attitudes to PowerPoint and Prezi presentation usage.

METHODS

The participants for this study were student biology who volunteered for this study. They were from the 3th and 4th university years at the Faculty of Natural Sciences, University of Maribor in Slovenia. They completed a questionnaire prepared for the purpose of the study. They completed it in electronic form. The questionnaire was prepared with Google Drive. We collected 63 questionnaires from 47 women (74.6 %) and 16 (25.4 %) men.

The questionnaire contained three parts. The first part of the questionnaire solicited demographic data such as gender. The second part concerned students' attitudes about usefulness of different presentations (Prezi and PowerPoint). The answers were measured by a 5-point Likert scale. The scale questionnaire was as follows: 0 = I have no base for answer; 1 = definitely disagree; 2 = disagree; 3 = agree; 4 = definitely agree. Students were to value percent's of their university professors' usage of presentations during lectures. The scale questionnaire was as follows: 1 = 0 – 24 %; 2 = 25 – 54 %; 3 = 55 – 74 %; 4 = more than 75%; 5 = all professors. The third part was an open question about advantages and disadvantages of Prezi and PowerPoint presentation. Similar answers were grouped in to four complexes which describe the same answers.

The reliability of the questionnaire about usefulness of different presentations (Prezi and PowerPoint) was measured by the Cronbach coefficient. The Cronbach reliability coefficient was 0.94 for the 7-item scale, which can be considered satisfactory. Microsoft® Excel 2010 was used for data input. The analyses were performed with the statistical package SPSS 21.0, where we used descriptive statistics; One-way ANOVA was used to examine differences in opinions by student gender why they use presentations. The Chi-Square test (χ^2) was not used for comparison of differences between results from the student opinions about the advantages and disadvantages of PowerPoint and Prezi presentation because we have no results of Prezi usage.

RESULTS AND FINDINGS

One of background question was when and where students learned about e-presentations. In a primary or secondary school 36 students (57.1 %) learned about presentation, 20 students (31.7 %) learned about presentation at university classes and just 6 students (9.5 %) claimed that they learned about presentation by them own across investigation. No one took the special lessons or training to learn about e-presentation.

In Slovenia in most know PowerPoint presentation, so the results are not surprises; the 57 students (90.5 %) use PowerPoint and just 6 students (9.5 %) use PowerPoint and Prezi presentations. We have no students to use just Prezi. Students mostly do not use the Prezi because they do not know it and almost the same results are at professors' usage of Prezi presentation. We asked students who many professors at lectures use presentations and 53 (84.1 %) students claimed that more than 75 % of professors during lectures use the presentations but less than 10 % of them use Prezi presentation. Across my researching I found at that Prezi use just one professor and his field is computer science.

With questioner we asked students about advantages and disadvantages of Prezi and PowerPoint presentations but we could not made s comparison of differences between results because just 6 students know the Prezi presentation and these results cannot be relevant. Students who use Prezi claimed that it is good because it is free of charge and because of zooming in and out it is more interesting than PowerPoint. Why students do not use other presentation than PowerPoint is clear out of those statements:

- "I saw Prezi presentation. It is very interesting but I do not use it because I do not know how".
- "I do not use the Prezi because all lecture room has no Internet connection".
- "I use PowerPoint presentation because I am familiar with it, it is accessible and mostly use it".
- "I will not use Prezi because it is too trumpery".
- "Prezi has no support for different plugins for Chemistry, Physic, Mathematic ... but PowerPoint has".
- "I use PowerPoint because I do not know the other presentation programs."
- "PowerPoint meets my all presentations needs and therefore I do not use other applications".

PowerPoint is a user-friendly package (Uz et al., 2010) and our study also confirms it. 54 (85.7 %) our students said that it is easy to use PowerPoint presentation. There are no significant differences at statement of using PowerPoint presentations by gender. Students mostly use it for the creation of visually clear. Three students (4.8 %) use it because the professors request. Even 6 (9.5. %) students thing just of herself; they use PowerPoint to make their oral presentation easier. These students are not interest in audience and how to effective to represent the contents but just to do it and by easier way. Out of this item these students while preparing PowerPoint presentations do not follow the principles that need to be followed.

Students need more instructions how effective make presentations. At the lectures they see finished presentations but they can to make it effective if they do not kwon how or if they do not follow the principles that need to be followed to make effective presentation.

CONCLUSION

Understanding the metaphors that underline PowerPoint, other tools like it, and differentiated tools such as Prezi give information designers valuable insight to guide their decision when choosing an appropriate presentation tool. The metaphor that underline Prezi afford it unique characteristic (concept-mapping), and the same is true for traditional tools such as PowerPoint. Although Prezi allows created concept-maps there is no clear indication that can positively affect learning outcomes, self-literacy, perceived mental effort and appreciation of the

learning material. Familiarity with these characteristics and their inherent strengths allows information designers to choose the tool most appropriate to the content and situation of their specific presentation (Bean, 2012) and it is up to everyone's IT skills, creativity and innovative inspiration to choose how to make the presentation. Regardless of the used software for creating a presentation and the purpose they are made for (e-lecturing, showing a work report or the conclusions of a research, explain complicated sciences phenomenon...), the presentations are extremely indispensable. The advantages of the presentations, no matter how they are built, are obvious: the conveyed message is clear, concise, systematized and structured; the message is accompanied by graphics elements; it is attractive, it stimulates curiosity and it holds audience's interest (Chicioreanu & Oproiu, 2012).

In further research we would like to represent Prezi presentation to our students and make them to use it. After some period of time we would like to find out which one of software presentation; Prezi or PowerPoint; they would like to prefer.

REFERENCES

- Ballentine, B.D. (2012). High Concept and Design Documentation: Using Prezi for Undergraduate Game Design. *Professional Communication Conference (IPCC)*, 2012 IEEE International, 1-5. doi: 10.1109/IPCC.2012.6408632
- Bean, J. W. (2012). Presentation Software Supporting Visual Design: Displaying Spatial Relationships with a Zooming User Interface. *Professional Communication Conference (IPCC)*, 2012 IEEE International, 1-6. doi: 10.1109/IPCC.2012.6408630
- Casteleyn, J. & Mottart, A. (2012). Presenting material via graphic organizers in science classes in secondary education. *Procedia – Social and Behavioral Sciences*, 69, 458-466.
- Chicioreanu, T. D. & Oproiu, G. C. (2012). New ways to present the information in the teaching activity, *The 8th International Scientific Conference eLearning and software for Education Bucharest*, April 26-27, 90-95.
- Gul, R.B. & Boman, J.A. (2006). Concept mapping: a strategy for teaching and evaluation in nursing education. *Nurse Education in Practice*, 6(4), 199-206.
- Johnson, D. & Christensen, J. (2011). A comparison of simplified-visually rich and traditional presentation styles. *Teaching of Psychology*, 38(4), 293-297.
- Kinchin, I. (2001). If concept mapping is so helpful to learning biology, why aren't we all doing it?. *International Journal of Science Education*, 23(23), 1257-1269.
- Levasseur, D. G. & Sawyer, J. K. (2006). Pedagogy meets powerpoint: a research review of the effects of computer-generated slides in the classroom. *Review of Communication*, 6 (1-2), 101-123.
- Sugahara, S. & Boland, G. (2006). The Effectiveness of PowerPoint presentations in the Accounting Classroom. *Accounting Education: An International Journal*, 15 (4), 391-403.
- Shaw, R.S. (2010). A study of learning performance of e-learning materials design with knowledge maps. *Computer & Education*. 54(1), 253-264.
- Uz, C., Orhan, F. & Bilgiç, G. (2010). Prospective teachers' opinions on the value of PowerPoint presentations in lecturing. *Procedia Social Behavioral Sciences*, 2, 2051-2059.
- Vecdi Can, A., Karaca, N., Akyel, N. and Demirci, S. D. (2012). Evaluating the Fitness of Lecturing with PowerPoint Presentation for Accounting Education – research at Sakarya University. *Social and Behavioral Sciences*, 55, 128-137. <http://dx.doi.org/10.1016/j.sbspro.2012.09.486>
- Zelev, E.V & Lenaerts, J. (2004). Improving the usefulness of concept maps as a research tool for science education. *International Journal of Science Education*, 26(9), 1043-1063.

İÇERİK YÖNETİM SİSTEMİ KULLANILABİLİRLİK DEĞERLENDİRMESİ: JOOMLA 3

USABILITY EVALUATION OF A CONTENT MANAGEMENT SYSTEM: JOOMLA 3

Özkan ÖZLÜ
Abant İzzet Baysal Üniversitesi
ozkanozlu@ibu.edu.tr

Pınar ONAY DURDU
Kocaeli Üniversitesi
pınar.onaydurdu@kocaeli.edu.tr

ÖZET: İçerik yönetim sistemleri özellikle programlama tecrübesi olmayan kullanıcıların web içerikleri oluşturmak için kullandıkları platformlardır. Bu amaçla kullanılabilen ve ücretsiz olan pek çok uygulama vardır. Kullanılabilirlik kavramı bu tip uygulamalar için anahtar özellik olarak karşımıza çıkmaktadır. Bu çalışma kapsamında dünya çapında yaygın olarak kullanılan Joomla'nın kullanılabilirlik testi yaklaşımı ile değerlendirilmesi gerçekleştirilmektedir. Teste 12 gönüllü katılmıştır. Katılımcılara 16 ana adım 64 işlemden oluşan bir kullanılabilirlik testi uygulanmış sonrasında da görüşlerini almak amacıyla kullanılabilirlik değerlendirme anketi uygulanmıştır. Görev tamamlama yüzdeleri, tecrübe durumu ve kullanılabilirlik faktörleri ile genel memnuniyet ilişkisi değerlendirilmiştir. Genel olarak kullanıcıların sistemi kullanmaktan memnun oldukları, pek az sorunla karşılaştıkları görülmüştür. Bildirilen sorunların başında anlaşılır olmayan sistem mesajları ve kodlama desteğindeki kısıtlar gelmiştir. Bu sorunlara ilişkin bazı çözümler önerilmiştir. Bunun yanı sıra anketten elde edilen genel memnuniyet değerleriyle görev tamamlama yüzdeleri arasında doğru orantılı bir ilişki saptanmıştır.

Anahtar sözcükler: Kullanılabilirlik, içerik yönetim sistemi, Joomla, web yayıncılığı, kullanılabilirlik testi

ABSTRACT: Content management systems are the platforms enabling users who have low programming skills to create web contents. There are many commercial and open source applications for this purpose. Usability is an essential key concept for this kind of applications. In the scope of this study, Joomla which is one of the widely used content management system was evaluated for its usability. A usability test consisting of 16 main steps and 64 procedures was conducted with 12 participants. Afterwards, usability questionnaire was applied. Overall satisfaction relation with task completion percentages, status of experience and usability factors has been evaluated. In general, users were satisfied with the system and encountered few problems. Unclear system messages and lack of coding support are stated main usability problems. Some solutions were provided. In addition, a close relation between overall satisfaction values which were gathered from the questionnaire and task completion percentages was determined.

Keywords: Usability, content management system, Joomla, web publishing, usability test

GİRİŞ

İçerik Yönetim Sistemleri (İYS) insanlar arasında hızlı, güvenilir ve kolay bir şekilde bilgi paylaşımını amaçlayarak ortaya çıkartılan ve son 20 yıl içinde kullanımları oldukça yaygınlaşan uygulamalardır. İçerik yönetim sistemi, müşterek bir ortamda iş akışını yönetecek işlem basamakları sağlar (Paulsen, 2011). Genellikle kodlama becerisi az ya da hiç olmayan kullanıcıların web içerikleri oluşturmalarını sağlamayı hedefleyen bu uygulamalarda kodlamadan kaçınmak amaçlansa da bazı özel durumlarda buna destek de sağlanmaktadır.

İçerik yönetim sistemleri ticari ve açık kaynak şeklinde ikiye ayrılabilir. Ticari bir İYS'nin sorunları üretici firmanın el değiştirmesi veya iflası sonucunda ürün desteğini kesmesi ve belirli bir ücret karşılığında hizmet vermeleri şeklinde sıralanabilir. Buna karşılık açık kaynak İYS'lerinin kaynak kodları ücretsiz olarak temin edilebilir ve ticari İYS'lere göre destek maliyeti çok daha ucuzdur. Kaynak kodların kolay erişimi her türlü ihtiyaca göre değiştirilebilmesi mümkündür. Bütün problemler, geliştirici topluluklarının sağladığı tavsiyelerle çözülebilir. Dolayısıyla zaman ve maliyet tasarrufunun yanı sıra üretkenlik artırılmış olur.

Açık kaynak İYS'ler de bir takım zayıflıklara da sahiptir. Kullanılabilirlik (Redding, Karreman & der Geest, 2008) ve erişilebilirlik (Rainville-Pitt & D'amour, 2009) açık kaynak İYS'lerdeki en ciddi problemler olarak görülebilir. Her ne kadar topluluk desteği etkin bir şekilde problemlere çözüm getirirse de sistemin yanında yeterli bir dokümantasyon mevcut değildir veya sınırlı destek sağlanmaktadır.

Kullanılabilirlik, tüm İYS'ler için anahtar bir unsurdur (Tiggeler, 2012). Kullanılabilirlik sistemin; amaca uygun, kullanımı kolay, etkili ve verimli olması şeklinde tanımlanmaktadır (ISO 9241, aktaran: Abran, Khelifi, Suryan & Seffah, 2003). Bilgisayar sistemlerinin tasarımcılarının işlevselliği kullanılabilirlik ile bir tutma veya kullanılabilirliği işlevselliğin önünde bir sınırlayıcı faktör olarak görme eğilimine karşın bir sistemin işlevlerinin etkili olması aslında onun kullanılabilirliğine bağlıdır (Goodwin, 1987). Günümüzde daha yeni, daha güçlü ve dolayısıyla daha karmaşık yapıdaki İYS'ler, artan işlevsellikleriyle kullanılabilirlikleri arasında bir denge göz önünde tutularak piyasaya sürülmektedir (Tiggeler, 2012)

Genellikle blog, haber veya alışveriş siteleri için kullanılmakta olan açık kaynak kodlu İYS'lerin içerisinde en yaygın kullanılan Joomla, Drupal ve Wordpress'tir (w3Techs, 2013). Bu çalışma kapsamında kullanılabilirlik değerlendirmesi gerçekleştirilen Joomla, 2009'da en iyi açık kaynak PHP İYS olarak değerlendirilmiş ve özellikle çoklu fonksiyonelliği intranet ortamlarında en iyi başarılan uygulama olarak belirlenmiştir (Patel, Rathod & Parikh, 2011). Tüm dünyada Joomla kullanan web sitesi sayısı ölçülemez de, kendi resmi sitesinde belirtildiği üzere, kurulum paketi bugüne kadar 35 milyon kez indirilmiş ve bugün, ortalama her 2,5 saniyede bir indirilmektedir (Joomla, 2013). Bu kadar yaygın olarak kullanılan bir ürüne ait herhangi bir kullanılabilirlik çalışmasının olmayışı bu araştırmanın temel motivasyonunu oluşturmaktadır. Yapılan kullanıcı deneyimi çalışmalarından yola çıkılarak Joomla için görev tabanlı bir kullanılabilirlik testi yapılmıştır.

YÖNTEM

Çalışmada kullanılabilirlik problemleri deneysel bir yöntem olan kullanılabilirlik testi yaklaşımı ile tespit edilmeye çalışılmaktadır. Kullanılabilirlik testleri hedef kullanıcıların sistemle etkileşimlerinin gerçek görevleri yerine getirirken gözlemlenmesine dayalı bir yöntemdir (Folmer & Bosch, 2004).

Katılımcılar

Kullanılabilirlik çalışmalarına katılacak katılımcı sayısına yönelik farklı yaklaşımlar mevcuttur. Virzi (1992) ve Nielsen (1993) 5 kişi ile kullanılabilirlik problemlerinin büyük bir çoğunluğunun tespit edilebileceğini savunurken Woolrych ve Cockton (2001) ise bu sayının her türlü durumda ideal olmadığını iddia etmektedir. Bu çalışma 12 katılımcı ile gerçekleştirilmiştir. Katılımcılardan altısı web programlama ile ilgilenen fakat herhangi bir Joomla sürümü ile bir web sitesi yönetmemiş kişilerden, diğer altısı ise daha önce en az bir Joomla sürümü kullanarak en az bir web sitesi yönetmiş kişilerden seçilmiştir. Gönüllü katılımcıların yaş, cinsiyet, meslek ve tecrübe süreleri Tablo 1'de verilmiştir.

Tablo 2. Katılımcıların Demografik Bilgileri

Gruplar	Yaş	Cinsiyet	Meslek	Tecrübe (ay)
Grup 1 (Tecrübeli)	21	K	Öğrenci	8
	20	E	Öğrenci	8
	20	K	Öğrenci	6
	33	K	Bilgisayar İşletmeni	36
	32	E	Uzman	32
	32	E	Öğretim Görevlisi	15
Grup 2 (Tecrübesiz)	23	E	Öğrenci	-
	25	E	Bilgisayar İşletmeni	-
	29	E	Bilgisayar İşletmeni	-
	34	E	Uzman	-
	37	E	Öğretim Üyesi	-
	42	E	Teknisyen	-

Veri toplama araçları

Kullanılabilirlik testi 16 ana adım ve 64 işlemden oluşan gerçek görevlerden oluşmaktadır. Görev listesi yer kısıtı nedeniyle burada paylaşılmamıştır ancak genel olarak kurulum gerçekleştirme ve yönetim panelinde kategori oluşturma, yeni menü ya da sayfa gibi bileşen oluşturma, yayınlama veya yayından kaldırma gibi Joomla ile gerçekleştirilebilecek görevleri içermektedir. Kullanıcıların görev tamamlama oranları belirlenmiştir

Kullanılabilirlik testi sonrasında kullanıcılardan görüşlerini almak amacıyla hazırlanan kullanılabilirlik değerlendirme anketini cevaplamaları istenmiştir. Computer System Usability Questionnaire (CSUQ) (Lewis,

1993) anketi Türkçeye çevrilerek adapte edilmiştir. Kontrol edilebilirlik, öğrenilebilirlik, arayüz kalitesi ve genel memnuniyet konularına yönelik yedili Likert ölçeğinde 19 ve 2 adet açık uçlu sorudan oluşmaktadır. Ankete verilen cevaplar ve görev tamamlama oranları göz önünde bulundurularak sistemin kullanılabilirliğine ilişkin çıktıların yorumlanması yapılmıştır.

BULGULAR

Görevlerin tamamlanma oranları ve genel memnuniyet ortalamaları Tablo 2’de verilmiştir. Tamamlama oranları ortalaması tecrübesiz grup için %83,85, tecrübeli grup için %95,57 olarak hesaplanmıştır. Tamamlanamayan görevlerin başında menü yapılandırması ve modül yerleşimleri gelmektedir.

Tablo 2. Grupların görev tamamlama oranları.

Gruplar	Katılımcı	Tamamlama Yüzdesi (%)	Tamamlama Yüzdesi Grup Ortalaması (%)	Genel Memnuniyet Ortalaması
Grup 1 (Tecrübeli)	K01	90,63	95,57	5,75
	K02	89,06		
	K03	100,00		
	K04	100,00		
	K05	93,75		
	K06	100,00		
Grup 2 (Tecrübesiz)	K07	89,06	83,85	5,45
	K08	81,25		
	K09	89,06		
	K10	87,50		
	K11	93,75		
	K12	62,50		

Joomla’nın kullanılabilirliğine ilişkin kontrol edilebilirlik (KE), öğrenilebilirlik (Ö), arayüz kalitesi (AK) ve genel memnuniyetin (GM) yer aldığı istatistiksel değerlendirmeler Tablo 3’te verilmiştir. Her dört faktörde de ortalama puan “iyi” derecesine karşılık gelen 5 puanın üzerindedir. Buna göre bütün faktörler, Joomla’nın kullanılabilirlik açısından başarılı olduğunu göstermiştir.

Tablo 3. Kullanılabilirlik faktörlerin istatistiksel değerlendirilmesi (N = 12)

	Kontrol Edilebilirlik (KE)	Öğrenilebilirlik (Ö)	Arayüz Kalitesi (AK)	Genel Memnuniyet (GM)
Ortalama	5,83	5,40	5,39	5,60
Standart Sapma	0,85	0,65	0,90	0,65
Maksimum	7,00	6,14	7,00	6,42
Minimum	4,00	3,86	4,33	4,37
Ortanca	6,00	5,43	5,33	5,71

Çoklu lineer regresyon analizinde, GM bağımlı; KE, Ö ve AK ise bağımsız değişkenler olarak ele alınmıştır. Elde edilen denklem (1)’de verilmiştir. Bu üç bağımsız değişken memnuniyetin varyansını %99,81 oranında açıklamaktadır.

$$GM = -0,055 + 0,179 \times AK + 0,400 \times Ö + 0,433 \times KE \quad (R^2 = 0,9981) \quad (1)$$

Tablo 4’teki model için verilen p değerinin 0,05’ten küçük olması, denklemde yer alan üç bağımsız değişken ile GM arasındaki ilişkinin açıklanmasında kullanılan çoklu lineer regresyon analizinin istatistiksel olarak anlamlı olduğunu belirtir.

Tablo 4. Çoklu Lineer Regresyon Analizinin Varyasyon Analiz Tablosu

	Kareler toplamı	Df	F	p
Model	4.6368	3	1474.11	0.0000
Kalan	0.0084	8		
Toplam	4.6452	11		

Kullanılabilirlik faktörleri, memnuniyet faktörü ve katılımcı özelliklerinin arasındaki ilişki ikili korelasyon analizi ile incelenmiştir (Tablo 5). İlk satır, parametreler arasındaki korelasyon katsayısını, parantez içindeki değerler ise olasılık değerini belirtmektedir. Yüzde 95 güven aralığında gerçekleştirilen analize göre p değerinin 0,05’ten büyük olması durumunda, belirtilen iki parametre arasında istatistiksel olarak anlamlı bir ilişkinin olmadığı söylenebilir. Korelasyon sayısı 1’e yaklaştıkça bu, ilişkinin kuvvetlendiğini gösterir. Katsayıdaki işaret ilişki yönünü belirtir. Buna göre AK, GM, Ö ve KE arasındaki ilişkinin kuvvetli olduğu görülmüştür. GM ile Ö ve KE arasında kuvvetli bir ilişki mevcuttur. Katılımcı özelliklerinden sadece cinsiyet (C) ile tecrübe durumu (TD) arasında bir ilişki gözlenmiştir. Bu ilişkinin diğerlerine göre daha düşük çıkmasının sebepleri cinsiyet

dağılımının homojen olmayışı (3 kadın, 9 erkek) ve tüm kadın kullanıcıların tecrübeli grupta yer almalarıdır. Son olarak, TD ile ilişkilendirilebilecek parametreler tecrübe süresi (TS) ve tamamlama yüzdesidir (TY).

Tablo 5. Kullanılabilirlik Faktörleri, Katılımcı Özellikleri ve Memnuniyet Arasındaki İkili Korelasyon Tablosu ($p < 0,05$, $N = 12$)

	GM	C	Ö	KE	TD	TS	Y	TY
AK	<u>0,909</u> (0,000)	0,187 (0,561)	<u>0,663</u> (0,019)	<u>0,700</u> (0,011)	0,194 (0,546)	0,209 (0,514)	-0,113 (0,728)	0,354 (0,259)
GM		-0,020 (0,950)	<u>0,726</u> (0,008)	<u>0,853</u> (0,000)	0,247 (0,440)	0,266 (0,403)	0,013 (0,969)	0,344 (0,274)
C			-0,066 (0,838)	-0,089 (0,784)	<u>0,577</u> (0,049)	0,176 (0,584)	-0,386 (0,215)	0,299 (0,345)
Ö				0,287 (0,367)	0,191 (0,551)	0,076 (0,815)	-0,238 (0,457)	0,016 (0,961)
KE					0,180 (0,577)	0,295 (0,351)	0,219 (0,495)	0,441 (0,151)
TD						<u>0,619</u> (0,032)	-0,402 (0,196)	<u>0,597</u> (0,040)
TS							0,106 (0,743)	0,553 (0,062)
Y								-0,168 (0,602)

Faktör analizinde girdi olarak kullanılabilirlik faktörleri (KE, Ö, AK), tecrübe bilgileri (TD, TS), TY, katılımcı özellikleri (C, yaş (Y)) ve GM kullanılmıştır. Eigen değeri 1'den büyük olan üç faktör (Şekil 3), toplam varyasyonun yaklaşık %80'ini açıklamaktadır. Her parametrenin yer aldığı faktördeki faktör yükleri Tablo 6'da verilmiştir. Analizde faktör yükü 0,5'ten büyük olan parametreler değerlendirilmiştir.

Tablo 6. Faktör Analizindeki Her Bir Bileşenin Faktör Yükleri

	Faktör 1	Faktör 2	Faktör 3
C	-0,076	0,395	<u>0,689</u>
Y	-0,092	0,075	<u>-0,885</u>
AK	<u>0,915</u>	0,188	<u>0,087</u>
GM	<u>0,965</u>	0,231	-0,086
KE	<u>0,726</u>	0,413	-0,363
TD	0,111	<u>0,733</u>	<u>0,544</u>
TS	0,086	<u>0,844</u>	-0,065
TY	0,198	<u>0,815</u>	0,132
Ö	<u>0,827</u>	-0,164	0,248
Varyans (%)	40,7	23,6	15,7

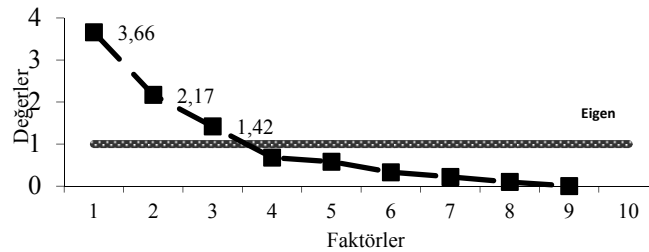

Şekil 3. Eigen değeri 1'den büyük olan faktörler.

Toplam varyansın %40,7'sini açıklayan Faktör 1 içerisinde AK, GM, KE ve Ö yer almaktadır. Tecrübe durumu (TD), TS ve TY'nin yer aldığı Faktör 2 toplam varyansın %23,6'sını açıklamaktadır. Faktör 3'te yer alan C, TD ve Y ise toplam varyansın %15,7'sini açıklamaktadır. Y parametresinin Faktör 3'te negatif çıkması diğer parametrelerle ters yönde bir ilişkiye sahip olduğunun göstergesidir. Diğer bir ifade ile kullanıcının yaş ilerledikçe kullanım memnuniyeti düşmektedir.

Ankette alınan kullanıcı yorumları, anketin üç alt ölçeğine göre gruplandırıldığında elde edilen bulgular anket sonuçlarıyla örtüşmektedir. Joomla'nın işlemleri hızlandırdığı dolayısıyla verim sağladığı, kullanımının kolay olduğu yönünde yorumlar yapılmıştır. Joomla'nın öğrenmesi kolay, zengin dokümantasyon ve bilgi kaynağına sahip olduğu belirtilmiş ancak hata mesajlarının, özellikle tecrübesiz kullanıcılar tarafından, tam olarak anlaşamadığı vurgulanmıştır. Arayüz kalitesine ilişkin olarak kodlama yetersizlikleri, sınırlı metin editörü seçenekleri ve içeriklerde tablo düzenlemelerinde sorunlar olduğu belirtilmiştir. Genel anlamda Joomla; basit, kullanışlı ve verimli olarak hemen hemen tüm kullanıcılardan olumlu yorumlar almıştır. Yaşanan en büyük problemlerin, modül oluşturma ve oluşturulan modülün sayfa atamalarında yaşandığı hazırlanan web siteleri incelendiğinde görülmüştür.

Kişi bazında GM ortalaması ile GTY'nin normalizasyon değerlerinin eğilimlerinde bir benzerlik tespit edilmiştir (Şekil 4). Ankete verilen cevap ortalamasını GTY'nin etkilediği söylenebilir. Diğer bir ifade ile kullanıcıların görevlerini tamamladıkça sistemi kullanmaktan daha memnun oldukları söylenebilir.

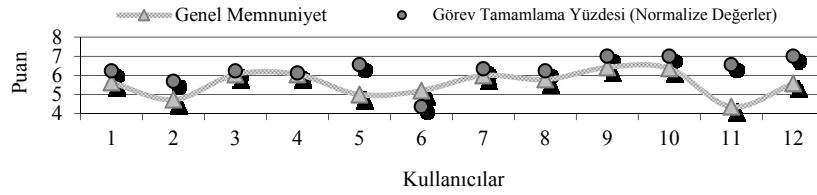

Şekil 4. GTY'nin Kullanıcı Memnuniyetiyle İlişkisi

SONUÇ

Bu çalışma kapsamında yaygın kullanılan İYS'lerden biri olan Joomla'nın en güncel sürümünün kullanılabilirlik testi yaklaşımı ile değerlendirmesi gerçekleştirilmiştir. Genel olarak tamamlanmayan görevlerdeki eksiklikler, modül konumlandırma ve sayfa seçimi ayarlarının yapılamayışından kaynaklanmaktadır. İkinci olarak menü ayarlamaları konusunda zorluklar yaşandığı ve hata mesajlarının çok anlaşılır olmadığı öne çıkmaktadır. Hatalı işlem durumunda, hatanın ne olduğu, neden kaynaklandığı ve çözüm önerilerini içeren kısa mesajlar gösterilmesi, kullanıcıların sistemi daha rahat kullanmalarını sağlayabilir. Joomla geliştiricilerinden ihtiyaç durumunda kullanıcının kodlama yapmaya imkân sağlayan kolaylıkların olmadığı kullanıcılar tarafından bildirilmiştir. Ancak sistem içinde kod yazmak için ortam sağlayan üçüncü parti eklentiler ile bu sorun ortadan kaldırılabilir. Senaryoda verilen görevleri tamamlama yüzdesi ile anketten elde edilen genel memnuniyet (GM) arasında bir ilişkinin olduğu gözlenmiştir. Anket ortalamasının "iyi" derecede çıkması ve tecrübe durumlarının bu ortalamayı etkilememesi Joomla'nın sunduğu arayüzün sezgisel olduğunu ve kullanılabilirlik açısından kullanıcılar üzerinde olumlu bir kanı oluşturduğunu göstermektedir.

Çalışma kapsamında tespit edilen problemler ve bunlara yönelik olarak geliştirilen önerilerin dikkate alınmasının sistemin iyileştirilmesi açısından uygulama geliştiricilere ve bu uygulamayı kullanmak üzere seçeceklere yardımcı olacağı düşünülmektedir. Daha fazla sayıda kullanıcının katılacağı ve farklı değerlendirme yöntemlerinin kullanılacağı araştırmaların gerçekleştirilmesi uygun olacaktır.

KAYNAKLAR

- Abran, A., Khelifi, A., Suryan, W., & Seffah, A. (2003). Usability meanings and interpretations in ISO standards. *Software Quality Journal*, 11(4), 325-338.
- Folmer, E., & Bosch, J. (2004). Architecting for Usability: A Survey. *Journal of systems and software*, 70(1), 61-78.
- Goodwin, N. C. (1987). Functionality and usability. *Communications of the ACM*, 30 (3), 229-233
- Joomla (2013). Joomla web site. Retrieved November 20, 2013 from <http://www.joomla.org/>.
- Lewis, J.R. (1995). IBM Computer Usability Satisfaction Questionnaires: Psychometric Evaluation and Instructions for Use. *International Journal of Human-Computer Interaction*, 7 (1), 57-78.
- Nielsen, J. (1993). *Usability Engineering*. San Diego, CA: Academic Press Inc.
- Patel, S. K., Rathod, V. R., & Parikh, S. (2011, December). Joomla, Drupal and WordPress - a statistical comparison of open source CMS. Proceedings from: *3rd International Conference on Trends in Information Sciences and Computing*, pp. 182-187.
- Paulsen, K. (2011). *Moving Media Storage Technologies: Applications & Workflows for Video and Media Server Platforms*. Francis US: Focal Press.
- Reddig, D., Karreman, J., & Van Der Geest, T. (2008). Watch out for the preview: The effects of a preview on the usability of a Content Management System and on the users' confidence level. Proceedings from: *IEEE International Professional Communication Conference*, (pp. 1-7).
- Rainville-Pitt, S., & D'amour, J.M. (2009). Using a CMS to Create Fully Accessible Web Sites, *Journal of Access Services*, 6 (1-2), pp.261-264.
- Tiggeler, E. (2012). *Joomla! : 2.5 Beginner's Guide*, Olton Birmingham: Packt Publishing Ltd.
- Virzi, R. A. (1992). Refining the test phase of usability evaluation: how many subjects is enough?. *Human Factors: The Journal of the Human Factors and Ergonomics Society*, 34 (4), 457-468.
- W3Techs (2013). World Wide Web Technology Surveys. Retrieved November 20, 2013 from <http://w3techs.com/>
- Woolrych, A., & Cockton, G. (2001, September). Why and when five test users aren't enough. Proceedings from: *IHM-HCI 2001 conference*, (2), pp. 105-108. Toulouse, France: Cepadéus.

DEVELOPMENT OF LEARNING MANAGEMENT SYSTEM (LMS) AS AN EFFORT IN INCREASING LEARNING EFFECTIVENESS AND LEARNING ACTIVITIES OF STUDENTS IN SRIWIJAYA UNIVERSITY

Ida SRIYANTI

^{1,3}Physics Education Study Program, Sriwijaya University, Indonesia
ida_sriyanti@yahoo.com

Jaidan JAUHARI

Faculty of Computer Science, Sriwijaya University, Indonesia
jaidan_j@yahoo.com,

Iftitah

Physics Education Study Program, Sriwijaya University, Indonesia
iftitasilviani@yahoo.com

ABSTRACT: The aim of this research was to develop LMS as an effort in increasing learning effectiveness and learning activities of students in Sriwijaya University. The method used in this research was development research method by applying a model proposed by Hanafin and Peck, with specific phases as analysis of necessities, design, development, and implementation. The subjects of this research were students in Physics Education Study Program in Sriwijaya University, Indonesia. Data collection techniques used in this research were questionnaire technique and observation. Validation result from media experts showed that mean of total validation score was of 4.41 indicating that our LMS used was absolutely valid. The effectiveness which was analyzed from students responses showed mean of total responses of 71.5% in one-to-one experiment phase, 82.32% in limited experiment phase, and 79.88% in class experiment; indicating that all of students responses was positive. Analysis of observational forms in term of active students learning showed that the total scores of observational forms was of 83.51%, which indicated that students were active in learning activities. We succeeded in developing LMS in Sriwijaya University.

Keywords: *e-learning*, LMS, development research, students activities, effectiveness.

Integrate : memadukan

INTRODUCTION

There are two facts about Informations and Communications Technology (ICT) in scientific literature. First, it is important to integrate ICT in science education. Research literature has shown that the use of ICT has a promising positive results in education. ICT supports students collaboration and knowledge building. In the context of science education, it also offers possibilities for interaction with the nature and tools for real-time data logging (Juuti, et. al., 2009). According to Twigg (2001), ICT creates transformative learning environment which provides individual approach and is suitable for students need. It also helps students to acquire and even use knowledge, skills, and attitude which are necessary for professional activity (Dwyer, 1999). Second, ICT has low levels of use in classrooms. A case study conducted by Istance and Kools (2013) in "OECD's New Millenium Learners Project" showed that since 2007, the gap between the current use of technologies for teaching and learning in schools and the daily experiences students have with technologies outside schools has been increasing. ICT can be used as an integral tool of laboratory-based practical activities to enhance students learning process, virtual alternative to real practical work, or a pedagogical tool for the teachers but classroom use remains scarce (Beaufils, 2005; Alev, 2003).

E-learning is a new form of learning organizations in the 21st century (Seok, 2008). E-learning is the use of ICT (e.g. internet, computer, mobile phone, Learning Management System (LMS), televisions, radios, and others) to enhance teaching and learning activities (Oye, et. al., 2012). In 1960s and 1970s, schools and universities started to use printed learning materials, television, radio, overhead projector (OHP) and movies in learning process (Nguyen, et. al., 2012). However, the rapid growth of computer (personal computer and notebook) and even smart phone in recent days has increased the use of ICT in classrooms. Thus, the use of ICT will adress e-learning activities.

Based on our own informal observations, we found that what is stated on OECD's Project was right. All of our students have their own gadgets (e.g. notebook, personal computer, mobile phone, smart phone, ipad, etc.) brought to the class. These gadgets will allow them to get information from world-wide sources so the focus of courses will not only be on textbooks anymore. Besides, Sriwijaya University (UNSRI) campus offers a free internet access (free wi-fi) for students and lecturers. Thus, both students and lecturers can access internet for teaching and learning purposes. These all factors enabled us to conduct research about e-learning as an effort to increase effectiveness in learning activities.

Introduction to Solid State Physics is one of the courses offered in our study program. According to our students, this course is relative hard to understand as the three-dimensional structure of solids including lattice and atoms, atomic binding, band gap, boundaries, and other abstract concepts are not easy to visualize. By this difficulties, the learning effectiveness was low and lecturers needed more time to explain the materials. Thus, we assume that we need to make a Learning Management System to help our students learn this course effectively.

As we know, LMS are software systems designed to support students learning activities (Ellis & Calvo, 2007). Usually, they contain a number of presentations, assessment, communication, and management tools. There are many kinds of LMS, such as Blackboard (Blackboard Inc.), Moodle, and Desire2Learn. The focuses of our research were the development of Learning Management System (LMS) by using Moodle (<https://elearning.unsri.ac.id>) and use of this LMS to increase effectiveness of our students learning activities.

METHODS AND PROCEDURES

Method used in this research was Development Research method. Our participants were 46 third year students who enrolled Introduction to Solid State Physics course. In this research, we developed LMS by using Moodle. In developing our LMS, we used Hannafin and Peck design model. The model (Suryana, et al., 2014) has three phases including Needs Assessment Phase (Phase I), Design Phase (Phase II), and Development/Implementation Phase (Phase III). Evaluation and revision were carried out throughout all three phases of this model. In Phase I we identified the objectives and learning materials to produce some learning units and to collect data which are related to the developed LMS which is used and another research publications which support our research. In Phase II we designed the LMS. In this phase, we produced story board documents of the LMS as an illustration for designing the LMS which would be developed. In Phase III we developed the story board documents so it became a complete LMS, and we implemented it on the one-to-one of the students, small group and classrooms.

During the three phases, we also had carried out the evaluation and revision processes. Before we implemented it on the one-to-one of the students, we had some expert validations process, including 2 media validators and 2 content validators. The media validators validated the e-learning media in terms of its simplicity, integration, emphasis, balance, and colors. The content validators validated the e-learning media in terms of its content fidelity and language.

The criteria of media and content validity were based on Kiswanto (2012). Mean score for each term criteria from four validators was gained from this formula:

$$K_i = \frac{\sum_{j=1}^n V_{ji}}{n}$$

where K_i was the mean score for i -th criteria, V_{ij} was the score of i -th criteria from j -th validator, and n is the number of validators. After we got the mean score for each criteria, we calculated the mean score for i -th aspect with this formula:

$$A_i = \frac{\sum_{j=1}^n K_{ij}}{n}$$

Where A_i was the mean score for i -th aspect, K_i was the mean score for the j -th criteria in i -th aspect, and n was the number of criteria in i -th aspect. Then, the mean of total validity scores was calculated with formula:

$$V_{amedia} = \frac{\sum_{i=1}^n A_i}{n}$$

Where V_{aMedia} was the mean of total validity scores and n was the number of criteria in i -th aspect. Based on Khabibah (Kiswanto, 2012), validity criteria was fitted by the following range: if $1 < V_{aMedia} \leq 2$ the e-learning is not valid, if $2 < V_{aMedia} \leq 3$ the e-learning is less valid, if $3 < V_{aMedia} \leq 4$ the e-learning is valid, and if $4 < V_{aMedia} \leq 5$ the e-learning is strongly valid.

After the implementation on one-to-one of the students, we had three students who had differences in term of cognitive level to complete the questionnaires in which they gave some suggestion for improving the e-learning media. After the small group implementation, we also had evaluation and revision process by choosing six students who had differences in term of cognitive level to complete questionnaires for improving the LMS. The revision of LMS based on the questionnaires was then used in classrooms.

The analysis of questionnaires was done by rating the statement expressed by students. If students “strongly agreed” with the statement in questionnaires, the score would be 5; if students “agreed” with the statement in questionnaires, the score would be 4; if students “were in doubt” with the statement in questionnaires, the score would be 3; if students “didn’t agree” with the statement in questionnaires, the score would be 2; and if the students “strongly didn’t agree” with the statement in questionnaires, the score would be 1.

Our developed LMS is considered as an effective e-learning if data collected from students responses were positive. Data from students responses were analyzed by calculating the mean of the number of student response for each statement with this formula:

$$R_{smedia} = \frac{\sum \text{score for each statement}}{n}$$

where R_{smedia} was the mean of all students responses scores for each statement and n is the number of students. The percentage of the number of student response for each statement were calculated with this formula:

$$\%R_{smedia} = \frac{\sum R_{smedia} \text{ for each statement}}{5} \times 100\%$$

According to Kiswanto (2012), there are 4 criteria of students responses: if the percentage of R_{smedia} is more than 85%, it means that the responses is strongly positive; if the percentage of R_{smedia} is more than 70% but less than 85%, it means that the responses is positive; percentage of R_{smedia} is more than 50% but less than 70%, it means that the responses is less positive; and if percentage of R_{smedia} is less than 50%, it means that the responses is not positive.

Beside giving the questionnaires to the students in classroom implementation, we also observed students learning activities to measure the learning effectiveness with using e-learning media. The observation was performed with using checklist and indicators. Students activities were scored by using rating scale with three criteria: if the student “completed 3 criteria”, the score would be 3; if the student “completed 2 criteria”, the score would be 2; and if the student “completed 1 criteria”, the score would be 1. In this research, we first calculated maximum score for each aspect according to the following formula proposed by Riduwan (2007):

$$\text{Total of maximum score for each aspect} = \text{maximum score for each aspect} \times \text{students}$$

Then we calculated score of all students for each aspect and students activeness percentage in learning process by using the following formula:

$$\%K_s = \frac{N_{smaks}}{N_{si}} \times 100\%$$

Where $\%K_s$ was the percentage of students activeness, N_{smaks} was the maximum score for each aspect, and N_{si} was the total score for all students in each aspect. After finding the percentage of students activeness, we fitted it with these criteria:

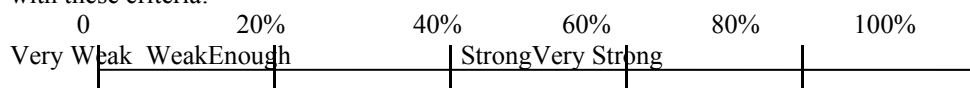

RESULT AND DISCUSSION

1. Needs Assessment Phase

In this phase, we identified the objectives and learning matters. Learning units were produced. Data which were related to the developed LMS, including publications of another research were collected to support our research. The analysis of needs assessment produced a prior concept of LMS which would be developed.

Firstly, we examined what courses are too difficult for students to understand. We found that Introduction to Solid State Physics was the most difficult course according to our students. It was quite reasonable as many concepts of this course (crystal structures, atomic binding, band gap, energy levels, lattice, etc.) were not easy to visualize. It needed more time for lecturers to explain the concepts more detail. Some lecturers had difficulties in drawing the crystal structures and explain the electron transfer. Students also needed more time to understand the explanations because the visualization was not good enough. They also needed some flash animations to recognize some learning materials.

In choosing the software for our LMS, we found that there are many industries offered software for LMS development. Some of these softwares were Blackboard, Desire2Learn, and Moodle. By some considerations, we finally chose Moodle as the software for our LMS. We found that many universities in and outside our country also used this software for developing LMS.

2. Design Phase

In this phase, we designed the LMS based on story board documents which had been developed before. In designing the LMS, we used Moddle application. Thus, our LMS have to be used in online. After the LMS created, we validated it to the validators, so there were improvements in terms of content and media features. Validation mean scores in term of media features from two media validators were of 4.41. It revealed that our developed LMS was valid in term of media features according to Kiswanto (2012). We also validated the LMS to the content validators. Validation mean scores in term of content fidelity and language from two content validators were of 3.14. It revealed that our developed e-learning was also valid in terms of content fidelity and language (Kiswanto, 2012).

3. Development/Implementation Phase

The designed LMS were then implemented on one-to-one students. Here we have chosen three students who were cognitively different to try our LMS out. After trying out, these three students were asked to complete questionnaires. The questionnaires were then used to measure students responses in e-learning process. Based on the analysis of completed questionnaires, we had mean score of students responses of 3.5 or 70%. It showed that the students had positive responses to the e-learning process. Because of this positive responses, our LMS were then continued to be implemented on small group. In small group implementation, we had chosen six students who were cognitively different to try our LMS out. After trying out, these students were asked to complete questionnaires. The questionnaires were then used to measure students responses in e-learning process. According to the analysis of completed questionnaires, we had mean score of students responses of 4.01 or 78%. It showed that the students had positive responses to the e-learning process. This positive responses showed that our LMS was effective and valid. This phase were also the final revision before the LMS was implemented to classroom.

In classroom implementation, we used the LMS for students learning activities in classroom. In this implementation stage, we used blended learning, which was a systematic mix of e-learning and learning in face-to-face context. However, using LMS in classrooms is not about teaching students only how to use the LMS or only teach students in traditional way. It is the combination of them. Thus, we used Technology Pedagogy Content Knowledge (TPCK) Model (Mishra & Koehler, 2006), which describes the inter-relationships between content, pedagogy, and technology. This model is a valuable theoretical conceptual framework as there is a balance between content, pedagogy, and technology. Thus, lecturers should not only be a passive facilitators, but also play an important role in engaging students in classroom activities.

To observe student activeness, we used such a checklist observation form. An accompanying teacher (observer) was asked to observe students and completed the checklist observation form. Data collected from observation forms showed that the mean percentages of students activeness was of 83.52%. It showed that the students were strongly active in e-learning. Thus, our developed e-learning had increased learning effectiveness and students activities in Physics Education study program in UNSRI.

CONCLUSION

We developed LMS for Introduction to Solid State Physics course. The design followed the research development method proposed by Hannafin & Peck. In Phase I, we identified the objectives and learning materials to produce some learning units and to collect data which are related to the developed LMS which is used and another research publications which support our research. In Phase II we designed the LMS. In this phase, we produced story board documents of the LMS as an illustration for designing the LMS which would be developed. In Phase III we developed the story board documents so it became a complete LMS, and we implemented it on the one-to-one of the students, small group and classrooms. During the three phases, we also had carried out the evaluation and revision processes. Validation mean scores in term of media features from two media validators were of 4.41. It revealed that our developed LMS was valid in term of media features. Based on the analysis of completed questionnaires, we had mean score of students responses of 3.5 or 70%. It showed that the students had positive responses to the e-learning process. Validation mean scores in term of content fidelity and language from two content validators were of 3.14. Data collected from observation forms showed that the mean percentages of students activeness was of 83.52%. It showed that the students were strongly active in e-learning. Thus, our developed e-learning had increased learning effectiveness and students activities in Physics Education study program in UNSRI.

REFERENCES

- Alev, N. 2003. "Integrating information and communications technology (ICT) into pre-service science teacher education: The challenges of change in a Turkish faculty of education". PhD Thesis at the School of Education, University of Leicester.
- Beaufils, D. 2005. "L'ordinateur outil de laboratoire en physique: guelles trans positions". Lyon: INRP.
- Cuban, L. 2001. *Oversold and Underused*.
<http://www.hull.ac.uk/php/edskas/Cuban%20article%20%20oversold.pdf>
- Dwyer, C. A. 1999. "Using emerging technologies to construct effective learning environments". Educational Media International Vol. 36 No. 4 p. 300 – 309.
- Istance, David and M. Kools. 2013. "OECD work on technology and education: Innovative learning environment as an integrating framework". European Journal of Education Vol. 48 No. 1 p. 43
- Juuti, K., J. Lavonen, M. Aksela, and V. Meisalo. 2009. "Adoption of ICT in science education: A case study of communication channels in a teachers' professional development project". Eurasia Journal of Mathematics, Science & Technology Education Vol. 5 No. 2 p. 103 – 118.
- Kiswanto, Heri. 2012. "Pengembangan media pembelajaran berbantuan komputer pada materi bangun ruang sisi lengkung". Jurnal 1 Vol. 1 p. 1 – 8.
- Mishra, P. and Koehler, M. J. 2006. "Technological pedagogical content knowledge: A framework for teacher knowledge". Teachers College Record Vol. 108 No. 6 p. 1017 – 1054.
- Nguyen, N., J. Williams, T. Nguyen. 2012. "The use of ICT in teaching tertiary physics: Technology and pedagogy". Asia-Pacific Forum on Science Learning and Teaching Vol. 13 No. 2 p. 1 – 18.
- Oye, N. D., A. Iahad, Madar, M. J., and Ab. Rahim N. 2012. "The impact of e-learning on students performance in tertiary institutions". International Journal of Computers and Wireless Communications Vol. 2 No. 2 p. 121 – 130.
- R. A. Ellis and Calvo, R. A. 2007. "Minimum indicators to assure quality of LMS-supported blended learning". Educational Technology and Society Vol. 10 No, 2 p. 60 – 70.
- Riduwan. 2007. *Belajar mudah penelitian untuk guru, karyawan, dan peneliti pemula*. Bandung: Alfabeta
- Seok, S. 2008. "Teaching aspects of e-learning". International Journal of E-learning Vol. 7 No. 4 p. 725 – 741.
- Suryana, I. M., N. Suharsono, I. M. Kirna. 2014. "Pengembangan bahan ajar cetak menggunakan model Hannafin & Peck untuk mata pelajaran rencana anggaran biaya". e-Journal Program Pascasarjana Universitas Pendidikan Ganesha Vol. 4
- Twigg, C. A. 2001. "Innovations in online learning: Moving beyond no significant difference". The Pew Learning and Technology Program. Accessible from <http://www.center.rpi.edu>.

TÜBİTAK WEB SİTESİNİN KULLANILABİLİRLİĞİNİN FARKLI YÖNTEMLER İLE DEĞERLENDİRİLMESİ

USABILITY EVALUATION OF TUBITAK WEB SITE BASED ON DIFFERENT METHODS

Serkan PELDEK

Bilgisayar Mühendisliği Bölümü, Kastamonu Üniversitesi, KASTAMONU
serkanpeldek@gmail.com

Pınar ONAY DURDU

İnsan Bilgisayar Etkileşimi Laboratuvarı, Kocaeli Üniversitesi, İzmit, KOCAELİ
pinar.onaydurdu@kocaeli.edu.tr

ÖZET: Bu çalışma kapsamında Türkiye’de çoğunlukla akademisyenler ve araştırmacılar tarafından sıklıkla kullanılan TÜBİTAK Web sitesinin kullanılabilirlik analizi gerçekleştirilmektedir. Çalışmanın birinci aşamasında akademisyenlerden oluşan 30 kişiye TÜBİTAK Web sitesinin kullanım amaçlarını belirlemeye yönelik bir anket uygulanmıştır. Anket sonuçları doğrultusunda bir sonraki aşamada uygulanan kullanılabilirlik testi için görev listesi oluşturulmuştur. Kullanılabilirlik testine katılan 7 katılımcının görevlerin yapımı sırasında karşılaştıkları zorluklar, yaptıkları hatalar, sesli düşünceleri not edilmiştir. Görevler tamamlandıktan sonra kullanıcılara kullanılabilirlik anketi uygulanmıştır. Çalışmanın son aşamasında 4 kullanılabilirlik uzmanı sitenin sezgisel değerlendirmesini gerçekleştirmiştir. Kullanıcı testi ile sezgisel değerlendirmede bulunan kullanılabilirlik sorunlarının çoğu benzerdir. Ancak birinin bulup diğerinin bulamadığı sorunlar olmuştur. Kullanıcı testinde kullanılabilirlik problemi olarak menü isimlendirmelerinde ve yapısındaki karmaşıklık, sistem durumunun görünür olmaması ve sistemin geleneklerle tutarsızlığı listelenmiştir. Sezgisel değerlendirmede ise yine sistemin görünürlüğünün az olması ve kullanıcı kontrolü problemleri ağır kullanılabilir sorunları olarak tespit edilmiştir.

Anahtar sözcükler: Kullanılabilirlik, kullanılabilirlik testi, sezgisel değerlendirme, TÜBİTAK web sitesi

ABSTRACT: In this study usability evaluation of TÜBİTAK website has been conducted. In the first phase of the study, a questionnaire was applied to 30 users to determine the intended use. Task list for the usability test was formulated based on its results. 7 participants were observed while performing these tasks. In the final phase, 4 usability experts conducted heuristic evaluation of the web site. The problems revealed by heuristic evaluation and usability testing were similar. However, there are some problems that one has found while the other cannot. Complexity in the structure and naming of the menu items, invisibility of system status and inconsistencies with conventions are listed as usability problems in usability testing. On the other hand, invisibility of system status and user control are stated as severe usability problems based on the heuristic evaluation.

Key words: Usability, usability test, heuristic evaluation, TÜBİTAK website

GİRİŞ

Kullanılabilirlik kavramı günümüzde herhangi bir yazılım ürünü için olmazsa olmaz kalite kriterlerinden biri haline gelmiştir. ISO standartlarında kullanılabilirlik kavramına yönelik kullanım kalitesi (ISO 9241) ve yazılım kalitesi (ISO/IEC 9126) olarak iki tanım yer almaktadır. Kullanım kalitesi sistemin ne derece etkin, verimli ve tatmin edici kullanılabildiğini, yazılım kalitesi ise kullanılabilirliğin belirlenen şartlar altında anlaşılacak, öğrenilecek, kullanılacak ve beğenilecek yazılım olma becerisini ifade etmektedir (Abran, Khelifi, Suryan & Seffah, 2003). Kullanılabilirlik birçok yönü ile özellikle ara yüz değerlendirmede birincil öneme sahiptir. Kullanılabilirlik ara yüz için öğrenilebilirlik, kullanım etkinliği, hatırlanabilirlik, yapılan hatalar, memnuniyet gibi olguları da içerisinde barındırır (Nielsen, 1993).

Son yıllarda organizasyonların dışarıya bakan yüzlerini oluşturan web siteleri için kullanılabilirlik olmazsa olmaz bir niteliktedir. Yapılan çalışmalar web sitesinin kullanılabilirliği arttıkça siteye olan güven artmakta ve bu da siteye olan sadakati artırmaktadır (Flavi’An, Guinal’lu, & Gurra, 2006; Robins & Holmes, 2007). Kullanılabilir olmayan bir web sitesinin alternatifleri tercih edilirken, bu durum kamu kurumlarına ait sitelerde

alternatifinin olmaması nedeniyle olumsuz sonuçlar doğurmaktadır. Bu nedenle kamu kurum web sitelerinin kullanılabilirliğinin değerlendirilmesi oldukça önem kazanmaktadır. Türkiye’de kamu kurum web sitelerinde kritik kullanılabilirlik sorunlarının olduğu ortalama bir vatandaşın bilgisayar kullanım becerisiyle ciddi sorunlar yaşadığı ortaya konulmuştur (Akıncı & Çağiltay, 2004).

Kullanılabilirlik değerlendirmeleri, kullanıcı memnuniyetini artırdığı, geliştirme maliyetlerini düşürdüğü ve sisteme olan olumsuz algıları azalttığı için oldukça önemlidir (Çağiltay, 2011). Kullanılabilirliğin değerlendirilmesine yönelik çeşitli yöntemler vardır. Zhang (2001, aktaran: Folmer & Bosch, 2004) kullanılabilirlik yöntemlerini test tabanlı, denetim tabanlı ve sorgulama tabanlı olacak şekilde üç başlık altında sınıflandırmıştır. Blanford ve arkadaşları ise (2004) çalışmalarında yöntemleri deneysel ve analitik olarak iki genel başlık altında gruplandırmışlardır.

Farklı kullanılabilirlik değerlendirme yöntemleri, farklı kullanılabilirlik problemlerinin tespitinde farklı derecelerde etkili olmaktadır. Sezgisel (Jeffries, Miller, Wharton & Uyeda 1991) değerlendirme az maliyet ve çaba ile en çok problem bulmayı sağlarken; deneysel kullanılabilirlik testi daha fazla ara yüz problemi bulmaktadır (Karat, Campbell & Fiegel, 1992). Sezgisel değerlendirme (Nielsen 2001), Nielsen’in 10 maddeden oluşan sezgisellerine dayalı olarak gerçekleştirilen analitik bir değerlendirme yöntemidir. Bu yaklaşımda değerlendiriciler bu 10 maddeyle sistemi değerlendirirler, bulunan problemleri listelerler ve bunlara ciddiyet derecesi vererek çözüm önerilerini belirlerler. Birden fazla uzman tarafında değerlendirme gerçekleştirildikten sonra herbirinin bulguları bir araya getirilerek değerlendirme tamamlanır. Kullanılabilirlik testi ise gerçek kullanıcıları ile gerçekleştirilir. Kullanıcılar görevleri gerçekleştirirken gözlemlenir ve karşılaştıkları problemler belirlenir.

Bu çalışma kapsamında Türkiye’de çoğunlukla akademisyenler ve araştırmacılar tarafından kullanılan TÜBİTAK Web sitesinin kullanılabilirlik analizi gerçekleştirilmektedir. Kullanılabilirlik problemlerinin tespitinde kullanılabilirlik değerlendirme yöntemlerinden sezgisel değerlendirme ve kullanılabilirlik testi yaklaşımları bir arada kullanılarak mümkün olduğunca çok problemin tespiti sağlanmaya çalışılmaktadır. Bu problemlerin tespiti ile sitenin daha kullanılabilir olmasını sağlayacak çözüm önerileri sunulabilecektir.

YÖNTEM

Süreç

Çalışma üç aşamada gerçekleştirilmiştir. Birinci aşamada sitenin kullanım amacı belirlenmiştir. İkinci aşamada kullanılabilirlik testleri yapılmış ve kullanılabilirlik değerlendirme anketi uygulanmıştır. Son aşamada sitenin sezgisel değerlendirmesi yapılmıştır. Çalışmanın akışı Şekil 1’de görülmektedir.



Şekil 1. Araştırma Akış Şeması

Katılımcılar

Üç aşamada farklı kullanıcılar yer almıştır. Birinci aşamada sitenin kullanım amacını belirlemeye yönelik 30 kişilik akademisyen grubuna bir anket uygulanmıştır. Bu grup 22 erkek ve 8 kadından oluşmaktadır. Katılımcıların yaş ortalaması 32’dir. Bilgisayar ve İnternet kullanım tecrübeleri iyi düzeydedir. Katılımcıların demografik bilgileri Tablo 1’de özetlenmektedir.

Tablo 3 TÜBİTAK Web Sitesi Kullanım Amacı Katılımcıları Demografik Bilgileri

Cinsiyet		Yaş		Enstitü		Fakülte			
Erkek	Kadın	25-35 yaş	35-45 yaş	Fen Bilimleri	Sosyal Bilimler	Mühendislik	İktisadi ve İdari Bilimler	Diğer	
22	8	25	5	17	13	8	14	8	
Bilgisayar kullanımı				Günlük bilgisayar kullanımı		Günlük internet kullanımı			
1-10 yıl		11-20 yıl		1-5 saat		6-10 saat		1-5 saat	6-10 saat

9	21	11	19	17	13
---	----	----	----	----	----

Çalışmanın kullanılabilirlik testi aşamasında 7 erkek katılımcı yer almaktadır. Yaş ortalaması 35'dir. Bilgisayar kullanım tecrübeleri iyi düzeydedir. Katılımcıların demografik bilgileri Tablo 2'de özetlenmektedir.

Tablo 4 Kullanım Testi Katılımcıları Demografik Bilgileri

Cinsiyet		Yaş		Enstitü		Fakülte			
Erkek	Kadın	25-35 yaş	35-45 yaş	Fen Bilimleri	Sosyal Bilimler	Mühendislik	İktisadi ve İdari Bilimler	Diğer	
7	0	4	3	4	3	3	3	1	
Bilgisayar kullanımı				Günlük bilgisayar kullanımı		Günlük internet kullanımı			
1-10 yıl		11-20 yıl		1-5 saat		6-10 saat		1-5 saat	6-10 saat
3		4		3		4		6	1

Son aşamada yer alan sezgisel değerlendirmeyi gerçekleştiren kullanılabilirlik uzmanlarının hepsinin bilgisayar kullanım tecrübeleri çok iyidir. Uzmanlardan üçü bilgisayar mühendisliği alanında yüksek lisans (1) ya da doktora (2) yapmaktadır. Dördüncü uzman ise endüstri mühendisliği doktora öğrencisidir.

Veri Toplama Araçları

Birinci aşamada web sitesinin kullanım amaçlarını ortaya çıkarmak ve kullanıcı testinde yer alacak görevleri oluşturmak için anket yoluyla veri toplanmıştır. Anket 14 ifadeden ve bir açık uçlu sorudan oluşmaktadır. İkinci aşamada kullanıcı testi kapsamında, katılımcılar 8 görev gerçekleştirmişlerdir. Görevler gerçekleştirilirken ekran ve ses kayıtları alınmıştır. Bu kayıtlar daha sonra incelenmiştir. Görevler sırasında katılımcılardan sesli düşünceleri istenmiştir. Yapılan hatalar, karşılaşılan zorluklar not edilmiştir. Görevlerin listesi Tablo 3'te yer almaktadır. Kullanıcı testi sonrasında katılımcılardan kullanılabilirlik değerlendirme anketi doldurmaları istenmiştir. 19 sorudan oluşan anketin birinci bölümünde demografik sorular, ikinci bölümünde ise 14 maddeden oluşan 5'li Likert ölçeğine dayalı "Website Analysis and Measurement Inventory" (WAMMI) anketinden Türkçe'ye çevrilerek adapte edilen kullanılabilirlik değerlendirmesi soruları yer almaktadır (Claridge & Kirakowski, 2013). Son aşama olan sezgisel değerlendirme, Nielsen'in (2001) 10 sezgiseline göre bir kontrol listesi hazırlanarak gerçekleştirilmiştir. Kullanılabilirlik konusunda eğitim almış uzmanlar siteyi değerlendirmiş ilgili sezgisele ait sorunları derecelendirmişlerdir.

BULGULAR

Kullanım Amacı Bulguları

TÜBİTAK web sitesinin kullanım amacı anketinde katılımcılar %100 oranda akademik destek programlarının hakkında bilgi olması gerektiğini belirtmişlerdir. Bilgi sunulması istenen konular arasında sanayi destekleri (%77), kamu destekleri (%77), girişimcilik destekleri (%73), bilimsel etkinlik destekleri (%76), bilim ve toplum destekleri (%71), AR-GE merkezleri (%80), ürün ve projeler (%84), bilimsel yarışmalar (%93), bilimsel olimpiyatlar (%79) ve bilimsel yayınlar (%79) başlıkları listelenmiştir.

Kullanıcı Testi Bulguları

Kullanılabilirlik testinde katılımcılar görev listesindeki görevleri gerçekleştirirken gözlemlenmişler; eğer görevi kısa sürede takılmadan gerçekleştirebildilerse "başarılı", eğer uzun sürede ya da yardım alarak gerçekleştirebildilerse "zorlandı", veya tamamlayamadıysa "başarısız" şeklinde değerlendirilmişlerdir. Görev performans tablosuna (Tablo 3) göre katılımcıların 4, 6, 7 ve 8 numaralı görevleri kolaylıkla başardıkları görülmektedir. Ancak diğer görevlerde başarısız oldukları ya da zorlandıkları da olmuştur.

Birinci görevi katılımcılardan sadece K_1 tamamlayabilirken; K_2 belli bir süre uğraştıktan sonra hangi menü altında olabileceği konusunda yönlendirme aldıktan sonra gerçekleştirebilmiş, diğerleri ise gerçekleştirememiştir. K_2, burslar adlandırmasının proje destekleri için olabileceğini düşünmediğini ve proje için aklına ilk gelen menünün Ar-Ge menüsü olduğunu belirtmiştir. K_3, istenilen yardım programını Hakkımızda menüsü altında aramış ve sonuçta görevi gerçekleştiremiştir. Bu görevde istenilen yardım programı burslar menüsü altındadır. Ancak katılımcıların projeye direk ilişkilendirdikleri isimler destek veya Ar-Ge olmuş ve bu nedenle Destek veya Ar-Ge Faaliyetleri menüsü altında aramıştır. Burs kelimesi genelde öğrencilerin eğitim yaşamlarında verilen yardım olarak algılanmıştır. İkinci sırada yer alan görevi yardım almadan sadece K_4 gerçekleştirebilmiştir. K_2 ise yardım aldıktan sonra yapabilmıştır. Yardımlar ana sayfaya gidip oradan bakmak veya diğer menüler altında olabileceğini hatırlatmak tarzında olmuştur. Görevi yaparken

üst menülerde kriptoloji ile alakalı alt menüler aranmış ancak fare ile üzerinden geçilmesine rağmen istenen birimin ismi fark edilememiştir. Katılımcıların hemen hepsi bu sorunu yaşamıştır. Katılımcılar görevi yapmaya çalışırken doğru üst menüye gitmişler ancak alt menülerin (yaklaşık 30 tane) çok olması nedeniyle bulamamışlardır. Üçüncü görevi K_1 yaparken, K_2 yardım olarak yapabilmıştır. Diğer katılımcılar ise yapamamışlardır. Katılımcılar görevin bağlantısını üst menülerde aramışlardır. Görevin bağlantısı ana sayfadır ancak haberlerin altında olduğu için fark edilememiştir. Fark edenlerin bağlantıda kullanılan resmin dikkat çekici özelliğinden yararlandıkları söylenebilir. Çünkü sağ tarafta menü kullanımı alışık olunmayan bir durumdur. Beşinci görevde yardım programının numarası da verilmiş ve bu arama özelliğini kullananlar için bir kolaylık olmuştur. Görevi tüm katılımcılar yapmıştır. 2 katılımcı yardım ve arama özelliğini kullanmadan yapmışlardır. Diğerleri arama özelliğini kullanmışlar veya yardım almışlardır.

Tablo 5. Görev Listesi ve Katılımcıların Görev Performansları

#	Görev Tanımı	Başarılı	Zorlandı	Başarısız
1	Öğrencilerle beraber geliştirdiğiniz bir projeye yardım almak için TÜBİTAK'ın verdiği desteklerden faydalanabileceğinizi öğrendiniz. Size uygun bir yardım programını bulunuz.	1	1	5
2	Kriptoloji alanında araştırma yapan iki tane birimin veya merkezin iletişim bilgilerine ulaşınız	1	1	5
3	Fizik alanında yayımlanan bir dergi bulunuz ve son sayısını indiriniz	2	1	4
4	Yazılım alanında düzenlenen yarışmaları bulunuz	6	1	0
5	Bilimsel çalışmalarınızda faydalanabileceğiniz 1505 nolu destek programı olduğunu öğrendiniz. İlgili duyuru ve başvuru şartlarını bulunuz	2	5	0
6	Parlak fikirleri olan ve girişimci birisine faydalanabileceği bir yardım programı arıyorsunuz size uygun programları bulunuz	7	0	0
7	Özel sektörün faydalanabileceği yardım programlarına nereden ulaşabilirsiniz?	7	0	0
8	Ulusal bilimsel olimpiyatlara katılma şartlarını bulunuz	7	0	0

Görev Sonrası Kullanılabilirlik Değerlendirmesi Anketi Bulguları

Katılımcılara uygulanan görev sonrası kullanılabilirlik değerlendirme anketinin sonuçlarına göre katılımcılar sistemde gezinirken zorluklar yaşamalarına karşılık bu durumu anket cevaplarına yansıtamamışlardır. Katılımcıların sistemin kullanılabilirliğine yönelik olumlu tutumlarının olduğu Tablo 4'den görülmektedir.

Tablo 6 Görev Sonrası Kullanılabilirlik Değerlendirmesi Anketi Sonuçları

	Katılmıyor	Fikri Yok	Katılıyor
Bu web sitesi ilgi alanıma girmektedir.			
Bu web sitesinde sayfalar arasında gezinmek zordur.	1	2	4
Bu web sitesinde istediğim bilgiye kolaylıkla ulaşabiliyorum.	3	1	4
Bu web sitesini kullanırken kontrolün bende olduğunu hissediyorum.	3	3	1
Bu web sitesini kullanırken nerede olduğunuzu hatırlamak güçtür.	4	0	3
Bu web sitesi aradığım bilgiyi bulmama yardımcı oluyor.	2	1	4
Bu sitede dolaşırken gitmem gereken yönü keşfetmek bir problemidir.	3	2	2
Bu web sitesini tasarımı genel olarak güzeldir	2	1	4
Bu web sitesini kullanırken kendimi yeterli hissediyorum.	2	1	3
Bu web sitesini ilk kez kullanırken hiç zorlanmadım.	2	2	3
Bu web sitesi kullanıcıyı rahatsız edecek bazı özelliklere sahip.	4	2	0
Bu web sitesi çok yavaştır.	6	0	1
Bu web sayfasında bir bağlantıya tıklayınca ihtiyacım olan şeye ulaşabiliyorum.	2	1	4
Bu web sitesindeki şekiller/ikonlar kolay anlaşılıyor	1	2	4

Sezgisel Değerlendirme Bulguları

Sezgisel değerlendirmede kullanılabilirlik uzmanları toplamda Tablo 5'de özetlendiği gibi 49 kullanılabilirlik sorunu bulmuştur. Bulunan sorunların 20 tanesi yüzeysel, 10 tanesi hafif, 13 tanesi ağır, 6 tanesi ciddi kullanılabilirlik sorunlarıdır. Toplamda farklı kullanılabilirlik sorunu 22 tane. Ciddi kullanılabilirlik problemleri özellikle sistem görünürlüğü ve kullanım kontrolü başlıkları altında yer almaktadır.

Tablo 7 Kullanılabilirlik uzmanlarının bulduğu kullanılabilirlik sorunları

	Bulunan kullanılabilirlik sorunları				
	1.uzman	2.uzman	3.uzman	4.uzman	Toplam
1)Sistem durumunun görünürlüğü	3	2	2	3	10
2)Sistem ile gerçek dünyanın eşleşmesi	1	1	0	3	5
3)Kullanıcı kontrolü ve özgürlük	1	2	1	4	8
4)Tutarlılık ve standartlar	1	1	1	2	5
5)Hataları önleme	0	1	1	1	3
6)Hatırlamak yerine tanıma	1	0	1	2	4
7)Esneklik ve kullanım verimliliği	1	2	1	4	8
8) Estetik ve sade tasarım	1	4	1	2	8
9)Kullanıcıya yardım olanağı tanımak, teşhis ve hata düzeltmek	1	0	1	2	4
10) Yardım ve dokümantasyon	1	1	1	1	4

SONUÇLAR

Bu çalışma kapsamında TÜBİTAK web sitesinin kullanılabilirlik testi ve sezgisel değerlendirme yaklaşımları ile kullanılabilirlik analizi yapılmıştır. İki farklı değerlendirme yaklaşımı kullanılarak bulunan problemlerin kapsamı ve geçerliliğinin artırılması hedeflenmiştir (Fenech Adami & Kiger, 2005).

Kullanıcı testinde katılımcılar ana menülerin altındaki sayfaları tahmin etmekte zorlanmışlardır. Katılımcıların çoğu ilk olarak yanlış bağlantıyı tıklamışlardır. Üst menülere verilen isimler ciddi kullanıcı sorunlarına sebep olmaktadır. Üst menüde sadece 4 başlık olması isimlendirmeyi daha önemli hale getirmektedir. İsimlendirme çok iyi yönlendirme yapmıyorsa bunun yerine üst menü sayısını artırmak kullanım kolaylığı sağlayacaktır. Üst menü altındaki menülerin çok fazla olması ve menü isimlerinin bir satırdan fazla yer alması ciddi kullanıcı sorunlarına sebep olmaktadır. Kullanıcı testinde ve sezgisel değerlendirmede bulunan sorunlar birbirleriyle örtüşmektedir. Kullanıcı testindeki katılımcıların görevleri yapmak için ana sayfaya dönmeleri, sitenin neresinden olduklarını bilememeleri ve uzmanların sistem görünürliğünün zayıf olduklarını belirtmeleri aynı soruna işaret etmektedir. Katılımcılar üst menünün değişmesinin gezintiyi zorlaştığını belirtmişlerdir. Aynı şekilde uzmanlar üst menünün değişmesinin kritik kullanıcı sorunu olduğunda hem fıkırdırler. Uzmanlar sağ tarafta ve altta menü olmaması gerektiğini belirtmişlerdir. Bağlantı menülerinin hepsinin yukarıda olması gerektiği ve sabit durmasını önermişlerdir. Ana sayfanın menülerde olmaması dikkat çekilen diğer bir husustur. Ana sayfa bağlantısı her zaman görünür bir yerde olmalıdır.

Çalışma kapsamında tespit edilen problemler ve bunlara yönelik olarak geliştirilen önerilerin dikkate alınmasının sistemin iyileştirilmesi yönünde katkı sağlayacağı düşünülmektedir. Daha fazla sayıda kullanıcının katılacağı ve farklı değerlendirme yöntemlerinin kullanılacağı araştırmaların gerçekleştirilmesi uygun olacaktır.

KAYNAKLAR

- Abran, A., Khelifi, A., Suryn, W., & Seffah, A. (2003). Usability meanings and interpretations in ISO standards. *Software Quality Journal*, 11(4), 325-338.
- Akncı, D., & Çağiltay, K. (2004). E-devlet Web Sitelerini Kullanmak ya da Kullanmamak: Vatandaş Açısından Kullanılabilirlik Sorunları Ve Öneriler. URL <http://www.metu.edu.tr/~kursat/TBD04-edevlet-Web siteleri.doc>
- Blandford, Ann, et al. "Analytical usability evaluation for digital libraries: a case study." *Digital Libraries, 2004. Proceedings of the 2004 Joint ACM/IEEE Conference on*. IEEE, 2004.
- Claridge, N., & Kirakowski, J. (2013). Web Site Analysis and Measurement Inventory. Retrieved 20 Aralık 2013, from <http://www.wammi.com/samples/index.html>
- Çağiltay, K. (2011). *İnsan bilgisayar etkileşimi ve kullanılabilirlik mühendisliği: Teoriden pratiğe*. Ankara: ODTÜ Yayıncılık.
- Fenech Adami, M., & Kiger, A. (2005). The use of triangulation for completeness purposes. *Nurse Research*, 12 (4), 19-29
- Flavián, C., Guinaliú, M., & Gurrea, R. (2006). The role played by perceived usability, satisfaction and consumer trust on website loyalty. *Information & Management*, 43(1), 1-14.
- Folmer, E & Bosch, J (2004). Architecting for usability: A survey. *The Journal of Systems and Software*, 70 (2004),61-78.
- Jeffries, R., Miller, J. R., Wharton, C., & Uyeda, K. (1991, March). User interface evaluation in the real world: a comparison of four techniques. In *Proceedings of the SIGCHI conference on Human factors in computing systems* (pp. 119-124).
- Jeffries, R., Miller, J. R., Wharton, C., & Uyeda, K. (1991, March). User interface evaluation in the real world: a comparison of four techniques. In *Proceedings of the SIGCHI conference on Human factors in computing systems* (pp. 119-124).
- Nielsen, J. (1993). *Usability engineering*. Boston: Academic Press.
- Nielsen, J. (1995). How to conduct a heuristic evaluation. URL <http://www.nngroup.com/articles/how-to-conduct-a-heuristic-evaluation/>
- Robins, D., & Holmes, J. (2008). Aesthetics and credibility in web site design. *Information Processing & Management*, 44(1), 386-399.

DEVELOPING GEOMETRICAL THINKING THROUGH MATHEMATIZATION

Zekeriya KARADAG
Bayburt University
zekeriya@bilelim.net

ABSTRACT: This paper summarizes a research done at a graduate course. The researcher investigates the mathematization experience of three graduate students while solving a geometry problem. The participants were expected to go through a vertical mathematization derived from a real life example. However, only one of the participants was successful on exploration whereas the other two failed going further. Data exploring the possible reasons puts forward that their learning habits hindered them from exploring the problem although they agreed on their current knowledge was sufficient to solve the problem.

Key words: Geometrical thinking, Mathematization, Qualitative research

INTRODUCTION

Realistic Mathematics Education (RME) is one of the leading theories getting more appreciation in recent years. The Realistic Mathematics Education (Freudenthal, 1991) framework suggests taking realistic examples from daily life and connecting it to mathematics. That is, mathematics in daily life should be observed and explored through horizontal mathematization and be extended up to higher levels through vertical mathematization (Treffers, 1987).

For examples, the following picture taken from an ordinary carpet illustrates a square like figure having some extensions at the corner (Figure 1). One can take this specific example by assuming the figure is a regular square with side a . Then, it would be great to extend each side by a certain amount such that he could construct an octagon through the end points of these extensions. Now the question would be how much should one extend sides? Maybe $\frac{a}{\sqrt{2}}$, maybe not!



Figure 1: A Carpet Illustrating A Square Like Figure

By assuming the figure on the square is a perfect square, one transforming this example on paper-and-pencil or any Dynamic and Interactive Mathematics Learning Environment (DIMLE) (Martinovic and Karadag, 2012) completes a horizontal mathematization process. However, elaborating the example little more and looking for

answer for the question, “what about constructing a polygon with 16-sided from an octagon through a similar method?” and even going furthermore and asking a generalization demonstrates a vertical mathematization.

Vertical mathematization

In order to initiate a vertical mathematization process, one should start with a square with a side a in length and construct an octagon. Now the best question at this moment would how much should we extend the sides to obtain an octagon. After a period of exploration at the paper-and-pencil environment, one may find the answer, $a/\sqrt{2}$, and then, in order to verify the answer start drawing a circle with radius, $= a/\sqrt{2}$, located its center at the one of the corners, say at B, of the square (Figure 2).

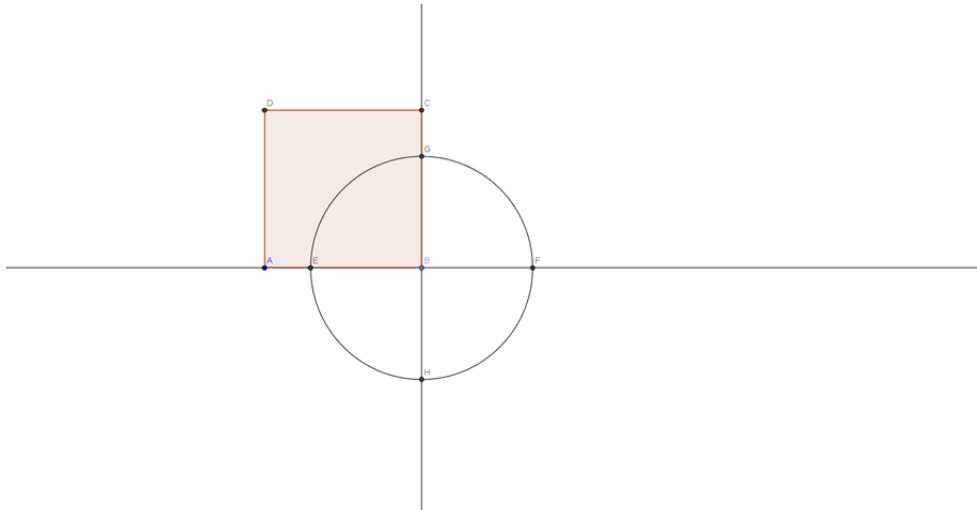

Figure 2: A Circle Created At The Corner B

Since the intersection points of the lines extending the sides and circle located its center B would be the two corners of the octagon we have been looking for, the rest of the construction would be easier. GeoGebra allows using a tool, helping to construct a polygon if two consecutive corners and the number of sides are known (Figure 3).

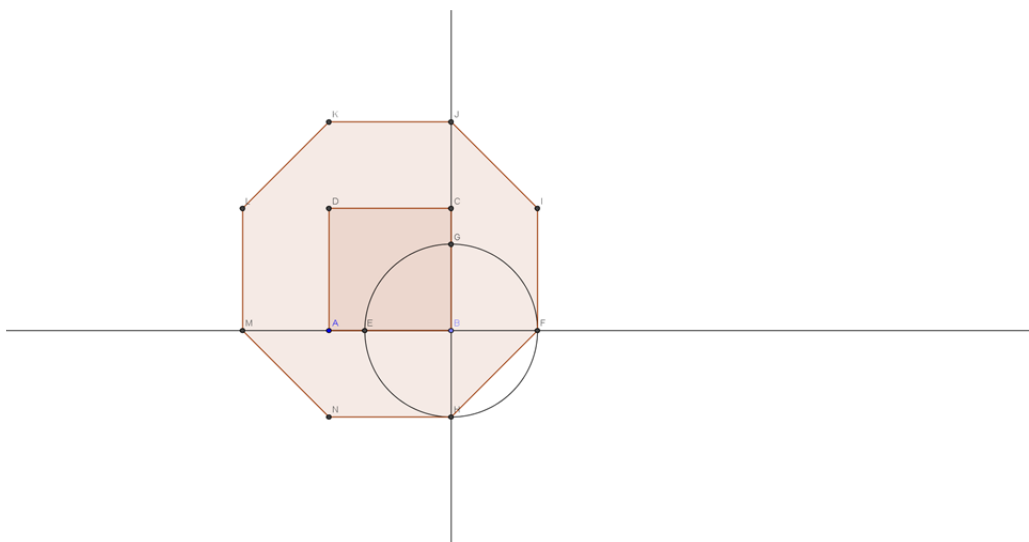

Figure 3: An Octagon Created Around The Square

One could follow similar procedures to construct polygons with 16-sided by drawing a circle at one of the corner with a radius of $R = a/\sqrt{2 - \sqrt{2}}$, 32-sided etc. However, a mathematician point of view seeks a generalization to accomplish this task if it is possible. Even it is impossible, mathematician needs to convince herself that the generalization problem has no solution. Fortunately, we have a solution for generalization.

Generalization

One having some experience with geometry in general, polygons in particular may assume that we need a formula consisting some angles, and therefore, may attempt to transform the relationships she developed into more trigonometric forms. For example, the following table summarizes these relationships in more tabular form (Table 1).

Table 2: A Summary Of Relationships Between The Sides And The Radii Of Circles

To construct	Start with	Draw a circle with radius
A octagon	a	$R = \frac{a}{\sqrt{2\left(1 - \cos\frac{\pi}{2}\right)}}$
A polygon with 16-sided	a	$R = \frac{a}{\sqrt{2\left(1 - \cos\frac{\pi}{4}\right)}}$
A polygon with 32-sided	a	$R = \frac{a}{\sqrt{2\left(1 - \cos\frac{\pi}{8}\right)}}$
A polygon with 2n-sided	a	$R = \frac{a}{\sqrt{2\left(1 - \cos\frac{2\pi}{n}\right)}}$

This table summarizes the findings of free exploration of the aforementioned vertical mathematization process. The following sections describe how participants could perform in following this anticipated mathematization path.

THE STUDY

This qualitative study explores the graduate students' experience while going through mathematization. The research problem for the study has been described as, "how could graduate students experience a non-routine geometry problem through vertical mathematization?"

In order to have them better understand mathematization processes, they were instructed on mathematization, including horizontal and vertical mathematization dimensions. Following the instruction, the carpet picture was shown, and how an octagon could be drawn starting from a square was demonstrated. Then, they were asked to elaborate the problem and to construct (1) a polygon with 16-sided by starting from a octagon and (2) a polygon with 32-sided by starting a polygon with 16-sided. Finally, they were asked if it would be possible to generalize the problem and to generate a formula holds true for all cases.

Participants were three graduate students studying mathematics education and taking a course named, "Teaching Geometry: Yesterday, Today, and the Future." Their teaching experience were at Grades 5-8 at various experience levels. Following the problem was exposed, they were given a week to work on the problem. After exploration time was completed, their results were asked to discuss the mathematization they needed to solve the problem and the challenge they had experienced.

Data included their work on paper-and-pencil and GeoGebra environments and informal interviews including their own reflections. In order to understand their experience the data was analyzed qualitatively. As Charmaz (2006) suggests seeking the truth in qualitative data analysis rather than looking for validity and reliability the data was triangulated with each other to make sure that the research results illustrates the truth.

FINDINGS

Interestingly, one out of three graduate was really succesful in this mathematization process whereas one of them had never done anything. One had declared an unsuccessful attempt. The one who had performed succesfully moved even further and developed a formula for another context.

She declared that once she completed the task she had asked herself “what if I start with triangle rather than a square.” Many mathematicians and mathematics educators suggest encouraging themselves to ask a similar question led them to pose new problems and deepen their understandings.

In contrast, asking the other two what held them to go further or why they could not solve the problem revealed that their learning habit of mathematics throughout their schooling years was the barrier for them to think further. They put forward that their learning habits of learning geometry led them absorbing some geometrical facts rather than exploring geometry by themselves.

RESULTS AND DISCUSSION

This qualitative study reflected on the graduate students’ experience while going through a mathematization process. The data suggests that schooling they had to go through developed a rote learning habit rather than an explorative way of learning. This claim was put forward by one of the participants, and the others also confirmed the claim. They argued that they were supposed to find some certain answers for the test questions on the standardized tests because of the education system they had to follow.

Despite the fact that they appreciated the mathematization they went through they still were unsure about the ways of implementing more problem solving and mathematization sections in their current courses. They claimed that it should be done through Ministry of Education.

REFERENCES

- Charmaz, K. (2006). *Constructing grounded theory: A practical guide through qualitative analysis*. London: Sage Publications
- Freudenthal, H. (1991). *Revisiting Mathematics Education. China Lectures*. Dordrecht: Kluwer Academic Publishers.
- Martinovic, D., & Karadag, Z. (2012). Dynamic and interactive mathematics learning environments: the case of teaching limit concept. *Teaching mathematics and its applications*, doi:10.1093/teamat/hrr029
- Treffers, A. (1987). *Three Dimensions. A Model of Goal and Theory Description in Mathematics Instruction*. Dordrecht: Reidel Publishing Company

EFFECT OF PROSPECTIVE SCIENCE TEACHERS' SCIENCE LABORATORY SELF-EFFICACY AND ATTITUDE SCORES AND PHYSICS, CHEMISTRY AND BIOLOGY LABORATORY ANXIETY SCORES IN TERMS OF SOME VARIABLES

Res. Asst. Eren YUCEL
Cumhuriyet University Faculty of Education
eyucel@cumhuriyet.edu.tr

Assoc. Prof. Dr. N.İzzet KURBANOGLU
Sakarya University Faculty of Education
kurbanoglu@sakarya.edu.tr

ABSTRACT: In this study; it has been investigated that the science laboratory self-efficacy and science laboratory attitudes points of science teacher candidates and the relationship between the anxiety points of physics, chemistry and biology laboratory and whether these variables make a difference according to gender and class levels. Sample of the study has been consisted of 685 science teacher candidate including 235 male and 450 female that studying in three different Faculty of Education. As data collection tool, Physics, Chemistry, and Biology Laboratory Anxiety and Science Laboratory Attitude and Self-efficacy Belief Scales have been applied at the second semester of the 2012-2013 academic years. Questions of the study have been analyzed with "Pearson Moment Correlation", ANOVA and "t-test". Results showed that between the science laboratory self-efficacy belief and science laboratory attitude points of students' have a positive and meaningful relationship and the science laboratory self-efficacy and science laboratory attitude and physics, chemistry and biology laboratory anxiety points have a negative and meaningful relationship. Students' science laboratory attitude and physics laboratory anxiety points showed meaningful differentness according to the gender. Moreover, students' science laboratory attitude points have showed a meaningful differentness according to the class level. Accordingly 2th grade students' attitude points have been seen more higher than 3th and 4th grade students'.

Key words: Self-efficacy, attitude, anxiety, gender and class level.

ASSESSING AND UPGRADING THE REALITY OF E-LEARNING AT TIKRIT UNIVERSITY

Qasim Mohammed HUSSEIN

Computer Science Department, College of Computer Science and Mathematics, Tikrit University
e-mail: kassimalshamry@yahoo.com

Essa Ibrahim ESSA

Computer Science Department, College of Computer Science and Mathematics, Tikrit University
e-mail: essaibrahimessa@yahoo.com

ABSTRACT: At this time e-learning still need more experiments in Iraqi universities, including the Tikrit university, needs to be a major effort and intensive process of development towards scientific progress growing in all the Arab countries and the world, for the purpose in this paper we will try to assessing the level of e-learning at Tikrit university, and know that reality and ways to promote it. The teachers do not ask students delivery duties on CDs, and do not use e-learning facilities. Through a questionnaire was distributed to members of the sample of teachers and students totaling 150. The statistical analysis showed that the percentage of responses is (agree, strongly agree, agree somewhat, don't agree, strongly disagree). In front of computer among the most important requirements necessary to build a system of e-learning at the Tikrit university, must be provide financial allocations, training courses, and the adoption of the computer literacy project.

Key words: E-learning, communication, interactive, multimedia, intranet, and availability.

INTRODUCTION

The progress growing and growing information and communication technology in this day and age and the environment interactive with these techniques help to overcome a lot of problems in the field of teaching by linking universities and educational institutions , and research and development centers informational using these techniques , and providing freedom of access to information and education resources , and this leads to an increase in the productivity of the educational process through the independence of time and place (Ahmed S. (2004) & Ali R. (1993)).

And the transformation of traditional learning environment to the environment depends on the knowledge of electronic networks could become a student and teacher of which store and retrieve data through various means, including the Internet. Depending on the ability of the beneficiary to obtain information and develop and employ them and make them available for others to take advantage of them , and so distasteful regimes teaching and learning of new and influential impact "positive " and those aspiring e-learning systems (Horton W. & Horton K. (2003) & Jacob H. (1997)).

PROBLEM OF THE STUDY

Still e-learning in the stages first a need to further testing and research and study and e-learning in Iraqi universities , including the Tikrit University requires great effort and intensive process of development towards scientific progress growing in all the Arab countries and the world , and for the purpose of assessing the reality of the level of e-learning at the Tikrit university, and the ways we will try to promote it in this research to find out the reality and ways to improve it in line to achieve international quality assurance standards.

THE MOST IMPORTANT FOUNDATION OF LEARNING TECHNIQUES

At the end of the last decade of the last century and early this century, and after the two world wars (first and second) appeared to use new types of communication media audio and video in education (such as photos, slides, movies, mobile recording devices, optical film, camera and video) , and the emergence of television and computer automation. We include below some of the most important foundations that underpin learning techniques at the present time:

- Contact the educational (the process of interaction between the two parties by the idea or opinion, or skill or a joint letter between them). .i
- Educational technologies (set of educational materials and services to increase efficiency within the classroom). .ii
- Interactive (the existence of the computer, interactive video, multimedia and the Internet). .iii

Collaborative (rendering software and teaching materials from colleges to individuals one at a time using the internet).	.iv
Asynchronization in space and time (progress subjects regardless of time and place for the teacher and the student and access to information in any time he pleases).	.v
Instructional design (the use of theory, practice in the design of processes, resources development, and management for education) (Frances D. (2007) & Taleb A. & Wolfgang H. (2008) & Brad M. et. al. (2009)).	.vi

THE CONCEPT OF E-LEARNING

With the use of modern technologies in teaching different subjects within the classroom and designed in an integrated manner based on the use and employ these techniques to be called education-mail (e-learning) is education , which employs an environment rich interactive applications on multiple computer technology and the World Wide Web (WWW) for information and availability of the teacher and the student in which access to resources at any time and from anywhere via the Internet and intranet, extranet (FAO Report (2011) & Debra P. & Zane L. (2006)). The e-learning contributes to the delivery of information and services, training and educational media provided directly to the homes of students and their places of work and therefore, the universities will benefit from the input of these technical studies to prepare and get results quickly (mSysTech (2009)).

THE OBJECTIVES OF THE E-LEARNING

The e-learning has a set of goals, including create an interactive learning environment provide a strengthen the relationship between the university and the community support the process of interaction between students and teachers through the exchange of experiences. On the other hand, its gives teachers and students technical skills up to date, modeling education and presented in the form of a standard, develop the role of the teacher in the teaching process, expand the circle of communication student through the WWW, create networks to organize and manage the work of academic institutions, and finally it provide education that fits different age groups , taking into account individual differences among them (Debra P. & Zane L. (2006) & mSysTech (2009)).

PROCEDURE

The procedures that have been followed in this study through a questionnaire on the study population academic and students to view a range of questions of (25) question included many themes (such as the axis of the use of e-learning at the university and the focus of interest of the e-learning) and through paragraphs questionnaire has been giving each response a certain degree to be processed accurately on the following pattern : strongly agree (5) grades, agree (4) grades, agree somewhat (3) grades, agree (2) grades, and strongly disagree (1) grades. As we see in Table 1 show the responses to the sample's (150) phrases resolution.

Table 1: The Responses To The Sample's (150) Phrases Resolution.

Seq.	Phrases	Degree Acceptance					Mean	Rank
			Strongly Agree	Agree	Agree Somewhat	Don't Agree		
.1	There are computer labs in college good enough	R	90	20	25	15	4,23	3
		%	60	13,4	16,6	10		
.2	Display devices used in teaching	R	89	19	22	20	4,16	5
		%	59,4	12,6	14,6	13,4		
.3	There are software - ready curriculum	R	35	51	34	18	3,52	13
		%	23,4	34	22,6	12		
.4	Bags are available in the college 's educational curriculum	R	2	18	72	10	2,31	19
		%	1,4	12	48	6,6		
.5	There Intranet available to teachers in college	R	74	41	22	13	4,16	5
		%	49,4	27,3	14,7	8,6		
.6	Teachers are trained in the use of modern methods of e-	R	50	49	26	9	3,96	10
		%	33,4	32,6	17,4	6		

	learning								
.7	Computer available to each student	R	7	11	19	62	51	1,83	23
		%	4,6	7,4	12,6	41,4	34		
.8	The teacher asks students delivery duties on CD-ROM	R	5	15	75	30	25	2,56	17
		%	3,4	10	50	20	16,6		
.9	Their College site on the Web	R	91	34	6	19	-	1,87	22
		%	60,7	22,6	4	12,7	-		
10	College provides technical support through specialists in computer and Internet	R	59	42	24	25	-	3,5	14
		%	39,3	28	16	16,7	-		
11	E-learning improves and increases self-education	R	60	59	19	12	-	4,01	7
		%	40	39,3	12,7	8	-		
12	E-learning improves students' levels and are driven to success	R	62	65	13	10	-	4,11	6
		%	41,3	43,4	8,6	6,7	-		
13	Are you with education via the Internet	R	60	49	18	23	-	3,96	9
		%	40	32,6	12	15,4	-		
14	E-learning increases the motivation of the learner to learn	R	72	42	36	-	-	4,24	2
		%	48	28	24	-	-		
15	I have an idea for e-learning and the formula	R	6	7	22	61	54	1,87	22
		%	4	4,6	14,7	40,7	36		
16	E-learning helps to communicate with the community	R	42	48	37	10	13	3,68	12
		%	28	32	24,7	6,7	8,6		
17	E-learning helps students retain information for longer periods	R	74	50	13	13	-	5,22	1
		%	49,4	33,4	8,6	8,6	-		
18	E-learning increases the burden on the student	R	5	15	34	60	36	2,92	15
		%	3,4	10	22,6	40	24		
19	The e-learning successful method from the viewpoint of students	R	49	50	34	7	10	3,73	11
		%	32,6	33,4	22,6	4,7	6,7		
20	Students are obligated to follow up on the vocabulary of subject	R	6	9	24	61	50	2,06	21
		%	4	6	16	40,6	33,4		
21	e-learning gives the freedom and flexibility to work in the classroom	R	65	59	22	4	-	4,22	4
		%	43,4	39,3	14,7	2,6	-		
22	Are you teaching with computers and their applications in all grades	R	61	49	20	20	-	3,99	8
		%	40,7	32,6	13,4	13,4	-		
23	The presence of electronic lectures and according to "	R	7	18	65	31	29	2,61	16
		%	4,6	12	43,4	20,6	19,4		

	international standards								
24	There are electronic subscription forums to exchange views and ideas	R	2	15	62	16	55	2,27	20
		%	1,4	10	41,3	10,6	36,7		
25	There are interviews with the students via the Internet	R	6	19	67	11	47	2,49	18
		%	4	12,7	44,6	7,4	31,3		

RESULTS

To get to know the reality of e-learning at the Tikrit university was calculated frequencies, percentages, and mean of the responses of the sample, as in Table 1. The study points out that there are phrases statistically significant through the arithmetic average grade as paragraph (17) retained the level first through grades approvals first three any exclusion of non-approval of the response of the sample agreed gain of (60%) of them on the existence of laboratories in the college in paragraph (1) did not agree with the gain of (10%) of them considered gain of (32.6 %) of them that way a successful e-learning in paragraph (19) in paragraph (2) gain of strongly agreed (59.4%) of them did not agree strongly with paragraph (4) gain of (32%) of them agreed strongly gain of (40%) of them with paragraph (13), while strongly disagree gain of (34%) of them with paragraph (7), while strongly disagree them gain of (36%) with paragraph (15) , and so on with the rest of the paragraphs in the Table 1. In the foregoing, the reality of e-learning at the Tikrit university needs to be more effort with the teacher and with the student, and the needs of infrastructure, provision of multimedia and technical support, and provide the Internet.

CONCLUSION AND SUGGESTIONS FOR FURTHER WORKS

The provision of infrastructure linking the home university qualify with other universities through a reliable network of contacts, providing staff trained and qualified to solve problems and support at any time require him to do so, training of teachers through (local, international training courses, and workshops), and increase the financial allocations as much as possible to e-learning projects at the university. The upgrading e-learning project needs to provide software packages that will support it and get to know the work of multimedia.

REFERENCES

- Ahmed S. (2004). (Ed.). Technology Education and e-learning.
- Ali R. (1993). (Ed.). The Concepts and Principles of Educational.
- Brad M. & Leslie B. & Tammy B. & Melonie & Jan L. & Janet M. & Lisa W. (2009). Usable E-Learning: A Conceptual Model for Evaluation and Design. *NC State University*. <http://www.ivls.org/>
- Debra P. & Zane L. (2006). Evaluation and e-Learning. *Turkish Online Journal of Distance Education-TOJDE January 2006 ISSN 1302-6488 Volume: 7 Number: 1 Article: 11.*
- FAO Report. (2001). E-learning Methodologies A Guide for Designing and Developing e-learning Courses.
- Frances D. (2007). Embedding Quality in e-Learning Implementation through Evaluation. *Educational Development, Coventry University, Coventry, United Kingdom, Educational Technology & Society, 10 (2), 34-43. 2007, f.deepwell @ coventry.ac.uk, http://www.ivls.org/*
- Horton W. & Horton K. (2003). (Ed.). E-Learning Tools and Technologies. *New York: Wiley.*
- Jacob H. (1997). (Ed.). Distance Education and Open University Education.
- mSysTech (2009). Evaluation of e-learning platforms. [http:// www.eWorks.de/](http://www.eWorks.de/).
- Taleb A. & Wolfgang H. (2008). Statistics E-learning Platforms Evaluation: Case Study. *Center for Applied Statistics and Economics, Berlin, Germany, 2008. http://www.ivls.org/*.

ORTAOKUL KADEMLERİNE YÖNELİK FEN VE MATEMATİK PROJE YARIŞMALARININ DEĞERLENDİRİLMESİ: TRABZON ÖRNEĞİ

Nilgün MİSİR

Mehmet YEREKAPAN

Erol ŞAHİN

Araştırmada 2005-2006 eğitim-öğretim yılı itibarıyla fen ve matematik alanında uygulanan, ortaokul düzeyine yönelik "Bu Benim Eserim" proje yarışmasına katılan projelerin eksik yönlerinin belirlenmesi ve bu eksikliklerin giderilmesine yönelik öneriler sunulması amaçlanmıştır. Araştırmanın verileri 2013-2014 eğitim-öğretim yılı Trabzon ilinden yarışmaya katılan 209 fen ve matematik projesinin, tarama modeline göre incelenmesinden elde edilmiştir. Projelerin incelenmesinde, projenin il ve bölge düzeyindeki değerlendirme kriterlerine göre hazırlanan anket kullanılmıştır. Anketten verilerine göre;projelerin çoğunlukla daha önce benzer yöntemlerle çalışılmış olduğu, proje süreçlerinde bilimsel basamakların yeterince uygulanmadığı, projenin yazılmasında ifadelerin istenilen düzeyde bilimsel açıklanamadığı sonuçları elde edilmiştir. Araştırmada tespit edilen eksikliklerin giderilmesine yönelik önlemlerin belirlenmesi amacıyla, fen ve matematik branşından 10 uzmana yönelik yarı-yapılandırılmış mülakat hazırlanarak veriler betimsel olarak analiz edilmiştir. Yapılan mülakatlar sonucunda, alan öğretmenleriyle işbirliğine girilerek proje konusunun belirlenmesi, bilimsel basamakların uygulanması ve proje raporu yazılmasıyla ilgili öğrencilerin geliştirilmesi, bununla birlikte fen ve matematik ders etkinliklerine proje sürecine ait bilimsel beceri ve tutumların entegre edilmesi gerektiği belirlenmiştir.

Anahtar Kelimeler: Fen ve Matematik Eğitimi, Bilimsel Süreç Becerileri, Proje Uygulaması

oooooooooooooooooooo

ORTAOKUL KADEMLERİNE YÖNELİK FEN VE MATEMATİK PROJE YARIŞMALARININ DEĞERLENDİRİLMESİ: TRABZON ÖRNEĞİ

Nilgün MİSİR

Mehmet YEREKAPAN

Erol ŞAHİN

Araştırmada 2005-2006 eğitim-öğretim yılı itibarıyla fen ve matematik alanında uygulanan, ortaokul düzeyine yönelik "Bu Benim Eserim" proje yarışmasına katılan projelerin eksik yönlerinin belirlenmesi ve bu eksikliklerin giderilmesine yönelik öneriler sunulması amaçlanmıştır. Araştırmanın verileri 2013-2014 eğitim-öğretim yılı Trabzon ilinden yarışmaya katılan 209 fen ve matematik projesinin, tarama modeline göre incelenmesinden elde edilmiştir. Projelerin incelenmesinde, projenin il ve bölge düzeyindeki değerlendirme kriterlerine göre hazırlanan anket kullanılmıştır. Anketten verilerine göre;projelerin çoğunlukla daha önce benzer yöntemlerle çalışılmış olduğu, proje süreçlerinde bilimsel basamakların yeterince uygulanmadığı, projenin yazılmasında ifadelerin istenilen düzeyde bilimsel açıklanamadığı sonuçları elde edilmiştir. Araştırmada tespit edilen eksikliklerin giderilmesine yönelik önlemlerin belirlenmesi amacıyla, fen ve matematik branşından 10 uzmana yönelik yarı-yapılandırılmış mülakat hazırlanarak veriler betimsel olarak analiz edilmiştir. Yapılan mülakatlar sonucunda, alan öğretmenleriyle işbirliğine girilerek proje konusunun belirlenmesi, bilimsel basamakların uygulanması ve proje raporu yazılmasıyla ilgili öğrencilerin geliştirilmesi, bununla birlikte fen ve matematik ders etkinliklerine proje sürecine ait bilimsel beceri ve tutumların entegre edilmesi gerektiği belirlenmiştir.

Keywords: Science and Mathematics Education, Science Process Skills, Project Implementation

ANALYSIS OF MATHEMATICAL PROBLEM SOLVING PROCESSES OF 6TH GRADE STUDENTS USING THE THINK-ALLOUD PROTOCOL

Zeynep iğdem ÖZCAN

Vildan KATMER-BAYRAKLI

Yeşim İMAMOĞLU

Problem solving is highlighted in many mathematics curricula and has recently become one of the most investigated topics in the field of mathematics education. There is an extensive amount of studies reporting that developing students' problem solving skills enhances their understanding of mathematics. Therefore, investigating problem solving processes of students is very important. One of the measurement techniques used in analyzing the problem solving process is the "think-aloud process".

This study investigates sixth grade students' think aloud processes while solving a mathematical problem verbally. The study group consists of 24 students (8 low, 8 moderate and 8 high achievers) selected from 69 sixth grade students according to the results of a problem solving test developed by the researchers. Think aloud process of each student was videotaped and transcribed. The collected data were first categorized as type (paraphrasing, elaborating, monitoring and identifying a problem) and then each type were coded as either facilitating or non-facilitating. The frequency of these categories were determined and compared according to students' success at solving the problem. Further analysis of students' problem solving process is continuing.

Keywords: Mathematical problem solving, think-aloud method, problem solving skill

FEN VE ETKNOLOJİ DERSİNDE BİLGİSAYAR DESTEKLİ PROJE TABANLI ÖĞRENME MODELİ UYGULAMALARI

Nİlgün MİSİR

Mehmet YEREKAPAN

Muhammet TÜRKMEN

Araştırmada fen ve teknoloji dersinde bilgisayar destekli proje tabanlı öğrenme modeli uygulamalarının öğrencilerin akademik başarılarına olan etkisinin belirlenmesi amaçlanmıştır. Araştırma Trabzon İl MEM'nin Comenius Bölge Projesi kapsamında, 2012-2013 eğitim öğretim yılı güz döneminde, Aalittin Akçay Ortaokulunda öğrenim gören 30 kontrol, 30 deney grubu olmak üzere toplam 60 8. sınıf öğrencisi ile yarı-deneysel yönetime dayalı olarak yürütülmüştür. Deney grubuna BIT destekli PTÖ modeline göre, kontrol grubuna ise klasik yönetime göre performans ödevleri verildi. Araştırmanın verileri öğrencilerin performans ödevleri ve ortak sınavlardaki başarılarının karşılaştırılması ile elde edilmiştir. Ortak sınavlardan elde edilen verilerin analizi SPSS.16 programında bağımlı t testi kullanılarak, performans ödevleri ise doküman analiziyle analiz edilmiştir. Yapılan analizler sonucunda deney ve kontrol grubu arasında, deney grubu lehine anlamlı fark olduğu tespit edilmiştir. Ayrıca yapılan doküman analizinde, deney grubunun bilimsel süreç becerilerini kullanma, rapor yazma, bilgisayar teknolojilerinden etkili ve bilinçli olarak yararlanarak bu yönde beceri geliştirme, öğretmenle işbirliği içinde öğrencilerin aktif olduğu ders ortamının oluşturulmasına katkı sağlama sonuçları elde edilmiştir. Araştırmada BIT destekli PTÖ modelinin farklı derslerde de kullanılması önerilmektedir.

Anahtar Kelimeler: Fen ve Matematik Eğitimi, Bilgi İletişim teknolojileri, Proje Tabanlı Öğrenme

oooooooooooooooooooo

FEN VE ETKNOLOJİ DERSİNDE BİLGİSAYAR DESTEKLİ PROJE TABANLI ÖĞRENME MODELİ UYGULAMALARI

Nİlgün MİSİR

Mehmet YEREKAPAN

Muhammet TÜRKMEN

Araştırmada fen ve teknoloji dersinde bilgisayar destekli proje tabanlı öğrenme modeli uygulamalarının öğrencilerin akademik başarılarına olan etkisinin belirlenmesi amaçlanmıştır. Araştırma Trabzon İl MEM'nin Comenius Bölge Projesi kapsamında, 2012-2013 eğitim öğretim yılı güz döneminde, Aalittin Akçay Ortaokulunda öğrenim gören 30 kontrol, 30 deney grubu olmak üzere toplam 60 8. sınıf öğrencisi ile yarı-deneysel yönetime dayalı olarak yürütülmüştür. Deney grubuna BIT destekli PTÖ modeline göre, kontrol grubuna ise klasik yönetime göre performans ödevleri verildi. Araştırmanın verileri öğrencilerin performans ödevleri ve ortak sınavlardaki başarılarının karşılaştırılması ile elde edilmiştir. Ortak sınavlardan elde edilen verilerin analizi SPSS.16 programında bağımlı t testi kullanılarak, performans ödevleri ise doküman analiziyle analiz edilmiştir. Yapılan analizler sonucunda deney ve kontrol grubu arasında, deney grubu lehine anlamlı fark olduğu tespit edilmiştir. Ayrıca yapılan doküman analizinde, deney grubunun bilimsel süreç becerilerini kullanma, rapor yazma, bilgisayar teknolojilerinden etkili ve bilinçli olarak yararlanarak bu yönde beceri geliştirme, öğretmenle işbirliği içinde öğrencilerin aktif olduğu ders ortamının oluşturulmasına katkı sağlama sonuçları elde edilmiştir. Araştırmada BIT destekli PTÖ modelinin farklı derslerde de kullanılması önerilmektedir.

Keywords: Science and Mathematics Education, Information Communication Technologies, Project-Based Learning

EXAMINATION OF SCIENCE TEACHER'S PEDAGOGICAL CONTENT KNOWLEDGE IN THE TOPICS RELATED TO ACIDS AND BASES

Munise SEÇKİN KAPUCU

Since 1986, following the introduction of content knowledge concept by Shulman, many researchers tried to understand the nature of pedagogical content knowledge. In this study, it has been planned to examine pedagogical content knowledge of two science teachers who have different teaching experiences, using qualitative research method. One of the teachers is female and has 2 years teaching experience, and the second teacher is male and has 31 years teaching experience. Both teachers are working in a public school in Eskişehir, during 2013-2014 academic year. Case study technique, which is thought to fulfill the aims of the research, has been selected as the research tool. Purposive and appropriate sampling technique will be used for the selection of teacher. Research data will be collected using a combination of observation, interview and document review techniques. Semi-structured interviews will be conducted with the science teachers at the beginning and at the end of the study. Moreover, teachers will be observed for 4 weeks, during the instruction of acids and bases topic. Descriptive analysis, content analysis and continuous comparison techniques will be used together to analyze semi-structured interviews conducted with teachers and documents. Following the completion of all analysis and interpretations, the results will be shared with the teachers and they'll be asked if these interpretations can be derived from his words (respondent's approval). Thus, the reliability of the analysis and interpretations will be increased. The data obtained from the study will be resolved in accordance with pedagogical components of the teachers. According to the findings, the recommendations which are thought to contribute to the pedagogical content knowledge of science and technology teachers will be given.

Keywords: Science Teachers, Pedagogical Content Knowledge (PCK), Acids and Bases.

İLKÖĞRETİM MATEMATİK ÖĞRETMENİ ADAYLARININ LİSANSÜSTÜ EĞİTİME YÖNELİK TUTUMLARININ BULANIK MANTIK İLE BELİRLENMESİ

DETERMINATION OF ATTITUDES FOR GRADUATE PROGRAM OF ELEMENTARY MATHEMATICS TEACHER CANDIDATES WITH FUZZY LOGIC

Elif BAHADIR
Yıldız Teknik Üniversitesi
ebahadir@yildiz.edu.tr

Ali BAHADIR
İstanbul Teknik Üniversitesi
abahadir@itu.edu.tr

Ahmet Şükrü ÖZDEMİR
Marmara Üniversitesi
ahmet.ozdemir@marmara.edu.tr

ÖZET: Bir kültür çalışanı olarak değerlendirilen öğretmenlerin niteliklerini arttırmak için günümüzde diğer alanlarda olduğu gibi eğitim alanında da gereklilik gibi görülen lisans üstü eğitim, geçmiş dönemlere nazaran daha önemli hale gelmiştir. Öğretmen adayların lisansüstü eğitime dair tutumları bu bağlamda oldukça önemlidir. Lisansüstü eğitime girişte Lisans mezuniyet ortalaması ve ALES puanı ağırlıklı olarak dikkate alınmaktadır. Araştırmamızda bu verilerin yanında öğretmen adaylarının tutumlarını da dikkate alarak, lisansüstü eğitime girişte bütün bu bileşenlerin bulanık mantık tabanlı bir değerlendirme ile yorumlanmasına yer verilmektedir. Bu çalışmada; öğrencilerin lisansüstü eğitime yönelik tutumlarının belirlenmesinde Ünal ve İlter'in (2010) yılında 5'likert tipinde hazırladıkları "lisansüstü tutum ölçeği" ile elde edilmiş sonuçların yanı sıra öğretmen adaylarının lisans mezuniyet ortalamaları ve ALES puanları da dikkate alınarak lisansüstü eğitime uygun öğrencilerin değerlendirmesi, bulanık mantık kurallarıyla gerçekleştirilmiştir. Çalışma 155 İlköğretim matematik öğretmenliği öğrencisi ile yürütülmüştür. Eldeki verilerin değerlendirmesi bulanık mantık yöntemi ile yapılmış ve bu yaklaşımla daha etkin ve doğru sonuçlara ulaşılabileceği gösterilmiştir.

Anahtar sözcükler: lisansüstü eğitim, bulanık mantık, tutum

ABSTRACT: To improve the quality of teachers who evaluated as an employee of a culture today as it was in other areas such as training requirements seen in the area of graduate education, has become more important than in the past period. The entrance to postgraduate education graduate degree and ALES are mainly taken into account. In our study, these data alongside the attitudes of teachers, taking into account all these components at the entrance to graduate education with an evaluation of the fuzzy logic-based interpretation is given. The analysis which was made with different components. In our study, we used the graduate attitude scale. The scale's findings with the baccalaureate and ALES are determined graduate education in consideration of eligible students by fuzzy logic 155 students applied to teaching elementary school mathematics scale assessment made by fuzzy logic method and results achieved with this approach was shown to be more effective and accurate.

Key words: graduate education, fuzzy logic, attitude

LİSELERDEKİ PERFORMANS GÖREVLERİ HAKKINDA ÖĞRETMEN GÖRÜŞLERİ

ASSESSMENT OF PERFORMANCE TASKS in HIGH SCHOOLS

Yasemin DEVECİOĞLU
Bayburt Üniversitesi Bayburt Eğitim Fakültesi İlköğretim Bölümü
ydevecioglu@bayburt.edu.tr

Recayi KAYMAKCI
Bayburt Üniversitesi Mühendislik Fakültesi
rkaymakci@bayburt.edu.tr

ÖZET: Bu çalışma, ortaöğretim kurumlarında görev yapan öğretmenlerin performans görevleri hakkındaki görüşlerini belirlemek amacıyla yürütülmüştür. Araştırmanın verileri 2013-2014 Eğitim-Öğretim yılı Güz döneminde Bayburt il merkezindeki liselerde görev yapan öğretmenlerden elde edilmiştir. Bu amaçla hazırlanan sekiz açık uçlu sorudan oluşan anket 37 lise öğretmenine uygulanmıştır. Anket sorularıyla öğretmenlerin performans görevlerinin amaçları, öğrencilere katkıları, performans görevlerinin değerlendirilmesi, süreçte karşılaşılan güçlükler hakkındaki düşünceleri ve önerileri belirlenmeye çalışılmıştır.

Öğretmenlerin ifadelerinden performans görevlerinin hem öğrenci hem de öğretmen için sorumluluk isteyen uygulamalar olduğu; öğrencilerin araştırmaya nerden başlayacağını bilmesi için öğretmenlerin öğrencileri yönlendirmesi, araştırma tekniklerini göstermesi, mevcut kaynakların etkin şekilde kullanılması ve velilerden doğrudan yardım almak yerine onların yol gösterici olması gerektiği yönünde durumlar belirlenmiştir. Öğretmenler, performans görevlerinin doğasına uygun olarak öğrencilerin araştırma yapmalarının önemini, aksi durumda bunun hiçbir katkısının olmayacağını vurgulamışlardır. Performans görevlerinin değerlendirilmesi konusunda sorunlar yaşadıklarını belirten öğretmenler, öncelikle yaşadıkları bölgede öğrencilerin imkânlarını dikkate aldıklarını, bu aşamada değerlendirme ölçeklerinden de faydalandıklarını söylemişlerdir.

Çalışmanın sonunda, performans görevlerinin öğrencilere daha yararlı olması konusunda öğretmenlerin görüşlerine ve bu alandaki çalışmalara dayalı bazı somut öneriler sunulmuştur.

Anahtar sözcükler: performans görevi, öğretmen, lise, görüş.

ABSTRACT: The aim of this study is to determine the teachers' opinions in high school about the performance tasks used newly. The study was conducted in the fall term of 2013-2014 academic year with the high school teachers from different branches such as physics, chemistry, mathematic etc. For this aim open-ended questions were applied to 37 teachers. By the open-ended questionnaire the teachers' preceptions about the aims of performance tasks, their contributions to students, evaluation of the tasks, problems during the task and suggestions about performance tasks were determined.

Research results showed that most of the teachers' have largely positive attitudes towards the performance tasks. They think that teacher and student have a great responsibility to perform the tasks successfully. The teachers believe the contribution of the performance tasks when it is performed with the aims of them.

The study was ended by the suggestions to realize the aims of the performance task in high schools.

Key words: performance task, teacher, high schools, opinion.

LİSE ÖĞRENCİLERİNİN FEN BİLİMLERİNDE KULLANILAN ÖLÇÜ BİRİMLERİYLE İLGİLİ BİLGİ DÜZEYLERİ VE DÜŞÜNCELERİ

THE LEVEL OF KNOWLEDGE AND OPINIONS OF HIGH SCHOOL STUDENTS WITH REGARD TO UNIT OF MEASURE USED IN SCIENCE AND TECHNOLOGY

Burcu ANILAN
Eskişehir Osmangazi Üniversitesi, Eğitim Fakültesi
burcud@ogu.edu.tr

ÖZET: Öğrenmede kalıcılığı sağlamanın en temel yollarından biri neden-sonuç ilişkisi kurmak, fen bilimleri için hem bir kolaylık hem de bir gerekliliktir. Bu nedenle öğrencilere fen bilimlerinde geçen kavramlar öğretilirken sabitler ve birimler kullanılarak formüllere ulaşılanın yolu ve mantığı kavratılmalıdır. Bu çalışmada orta öğretim öğrencilerinin söz konusu birim ve sembollerini bilip bilmediklerinin belirlenmesi ve bu birimlerin kullanılmasına yönelik görüşlerinin bazı değişkenler açısından farklılık gösterip göstermediğinin belirlenmesi amaçlanmıştır. Araştırmaya 2010-2011 eğitim-öğretim yılında Eskişehir il merkezindeki ortaöğretim kurumlarında öğrenim gören 354 öğrenci katılmıştır. Genel olarak bakıldığında ortaöğretim öğrencilerinin ölçü birimleriyle ilgili bilgi düzeyleri yeterli seviyede değildir. Öğrenciler sınavlarda birimlerden puan kırılmaması gerektiğini, birimleri doğru yazmaya çalışmanın soru çözümünde zaman kaybı yarattığını düşünmektedirler. Ancak bununla birlikte birimlerin belirtilmesinin önemli olduğunu vurgulamaktadırlar.

Anahtar sözcükler: ölçü birimi, birim, sembol, ortaöğretim

ABSTRACT: One of the most basic ways of ensuring persistence in learning establishes cause-effect relationships, as well as an ease for the sciences and is a requirement. Therefore, you should use the constants and units of ways and means of achieving the formulas while teaching the concepts to students in science. In this study, high school students if they know what these units and symbols identifying and opinions on the use of these units in terms of some variables was to determine whether there is a difference. 354 students who study in the field of science education in high schools in Eskişehir in the 2010-2011 academic years participated to this research. Overall, the level of knowledge about the unit of measure of secondary school students is not sufficient. Students believe that should not be break points in the examinations, trying to write the units correct is to cause loss of time in solution to the question. But it is important to emphasize specifying the units.

Key words: measurement unit, unit, symbol, high school

GİRİŞ

İnsanoğlunun varoluşu ile kıyaslama ihtiyacı başlamıştır. İnsanoğlu bir şeyin uzunluğunu, büyüklüğünü ve ağırlığını kıyaslamak için öncelikle çevresinde gözlemlediği ve kolayca ulaşabildiği nesnelere ve vücudundaki bazı uzuvları kullanma yoluna gitmiştir. Ölçü birimlerinin ortaya çıkışı ve ölçü birimlerine duyulan ihtiyaç da bu şekilde başlamıştır. Öte yandan aynı büyüklüğün farklı yerlerde değişik bir birimle ölçülmesi günlük yaşamda, ticaretle, sanayide, sağlıkta ve özellikle bilim dünyasında büyük karışıklıklara yol açmıştır. Bu karışıklığa son vermek amacıyla 1960'ta Birleşmiş Milletler örgütünün öncülüğünde uluslararası bir ölçü sistemi oluşturulmuştur. Fransızca adı *Systeme Internationale d'Unites* (Uluslararası Birimler Sistemi) olan ve tüm dünyada SI kısaltmasıyla bilinen yedi niceliği simgeleyen yedi temel birim ve sembolden oluşan bu birim sistemi, bilim dünyasında da büyük ölçüde benimsenerek öğretilmeye ve kullanılmaya başlanmıştır (Yalçiner, 2001).

Fen bilimleri derslerinde birçok kavram, sabit ve sembol öğretilmektedir. Ancak sadece kavramların bilinmesi yeterli değildir, bu kavramlara ilişkin formüllerde geçen sabitlerin tanınması ve formülün biriminin de bilinmesi önemlidir. Bununla birlikte çoğu zaman, birimlerden yola çıkarak formüllere ulaşılması ise ezberlemeye gerek duymadan konunun daha iyi anlaşılmasını sağlar. Ancak sembol ve birimlerin çoğu öğrenciler tarafından önemsenmemekte ve kullanılmamaktadır. Birim ve sembollerini kullanmadan sadece formülleri ezberleyerek yapılan işlemler sadece o anı kurtaran ve kısa süreli başarıyı getiren geçici çözümlerdir. Oysa öğrenmede

kalıcılığı sağlamanın en temel yollarından biri de neden-sonuç ilişkisi kurmaktır. Bu fen bilimleri için hem bir kolaylık hem de bir gerekliliktir. Bu nedenle öğrencilere fen bilimlerinde geçen kavramlar öğretilirken sabitlerin ve birimlerin kullanılarak formüllere ulaşılmasının yolu ve mantığı kavratılmalıdır.

Bu çalışmada orta öğretim öğrencilerinin söz konusu birim ve sembollerini bilip bilmediklerinin belirlenmesi ve bu birimlerin kullanılmasına yönelik görüşlerinin bazı değişkenler açısından farklılık gösterip göstermediğinin belirlenmesi amaçlanmıştır. Bu temel amaç doğrultusunda aşağıdaki sorulara yanıt aranmıştır.

1. Ortaöğretim öğrencilerinin, fen bilimleri derslerinde kullanılan uluslararası birimler ve sembollerle ilgili bilgi düzeyleri nedir?
2. Ortaöğretim öğrencilerinin, fen bilimleri derslerinde kullanılan birim ve sembollerin kullanılmasına yönelik görüşleri nelerdir?
3. Ortaöğretim öğrencilerinin, fen bilimleri derslerinde kullanılan birim ve sembollerin kullanılmasına yönelik görüşleri cinsiyet, sınıf düzeyi ve okul türüne göre farklılaşmakta mıdır?

YÖNTEM

Araştırma Modeli

Ortaöğretim öğrencilerinin fen bilimlerinde kullanılan birim ve sembollerini bilip bilmediklerini ve bu birimlerin kullanılmasına yönelik görüşlerinin bazı değişkenler açısından farklılık gösterip göstermediğinin belirlenmesini amaçlayan bu çalışma, betimsel tarama türünde bir araştırmadır. Bilindiği üzere tarama çalışmaları geçmişte ya da halen var olan bir durumu var olduğu biçimiyle betimlemeyi amaçlayan çalışmalardır (Cohen, Manion ve Morrison, 2000; Karasar, 2013).

Örneklem

Araştırmanın örneklemini 2010-2011 eğitim-öğretim yılında Eskişehir’de dört farklı ortaöğretim kurumunun 10. ve 11. sınıfta öğrenim gören, 109’u kadın ve 245’i erkek, 354 ortaöğretim öğrencisi oluşturmaktadır. Araştırmaya katılan öğrencilere ait bireysel özellikler Tablo 1’de verilmiştir.

Tablo 1. Araştırmaya Katılan Öğrencilerin Bireysel Özellikleri

Bireysel Özellikler		f	%
Cinsiyet	Kadın	109	30,8
	Erkek	245	69,2
Sınıf düzeyi	10	92	26,0
	11	262	74,0
Okul türü	Anadolu lisesi	47	13,3
	Meslek lisesi	181	51,1
	Fen lisesi	45	12,7
	Genel lise	81	22,9
TOPLAM		354	100,0

Veri Toplama Aracı

Araştırmada veri toplama aracı olarak anket formu kullanılmıştır. Anket, üç bölümden oluşmuştur. Anketin birinci bölümünde araştırmaya katılan ortaöğretim öğrencilerinin bireysel özelliklerini (cinsiyet, sınıf düzeyi, okul türü) belirlemeyi amaçlayan maddeler yer alırken; ikinci bölümde fen bilimleri derslerinde kullanılan uluslararası kabul görmüş birimler ve sembollerini bilip bilmediklerini ölçen 25 madde yer almaktadır. Üçüncü bölüm ise, birimlerin kullanılmasına yönelik görüşleri belirlemeyi amaçlayan maddeleri içermektedir (Yıldırım ve İlhan, 2007). Veri toplama aracının geçerlik ve güvenilirliği için bazı işlemler yapılmıştır. Buna göre veri toplama aracının kapsam geçerliliği için iki alan uzmanının görüşüne başvurulmuştur. Güvenirlik için ise Likert tipi ölçekler için en uygun yol olan Cronbach Alpha katsayısı (Tezbaşaran, 1997) hesaplanmıştır. Anketin Cronbach Alpha iç tutarlılık katsayısı 0.79 bulunmuştur. Bu işlemlere dayalı olarak veri toplama aracının geçerli ve güvenilir olduğu kabul edilmiştir.

Verilerin Analizi

Araştırmanın verileri SPSS programında çözümlenmiştir. Veri toplama aracına verilen yanıtların frekans, yüzde ve aritmetik ortalama (\bar{X}) değerleri hesaplanmıştır. Ortaöğretim öğrencilerinin fen bilimlerinde kullanılan birim ve sembollerini bilip bilmediklerini ve bu birimlerin kullanılmasına yönelik görüşlerinin bazı değişkenler açısından farklılık gösterip göstermediğinin incelenmesinde ise her bir anket maddesine verilen yanıtların

analizi için parametrik ya da nonparametrik testlerden hangilerinin kullanılacağına karar vermek için verilerin normal dağılıp dağılmadığına bakılmıştır. Bunun için Kolmogorov-Smirnov testi uygulanmış ve verilerin normal dağılmadığı görülmüştür ($p < .05$). Bu nedenle verilerin çözümlenmesinde nonparametrik testler kullanılmıştır. Buna göre verilerin çözümlenmesinde iki değişkenli karşılaştırmalarda Mann-Whitney U Testi, üç ve daha çok değişkenli karşılaştırmalarda da Kruskal-Wallis Testi uygulanmıştır. Anlamlılık düzeyi .05 olarak alınmıştır. Veri toplama aracında ikinci bölüm yer alan ifadeler için “doğru” ve “yanlış”, üçüncü bölümde yer alan ifadeler için “Hiç Katılmıyorum” (1), “Katılmıyorum (2), “Kararsızım (3)”, “Katılıyorum (4)” ve “Tamamen Katılıyorum (5)” dereceleri kullanılmıştır. Aritmetik ortalamalar yorumlanırken 1.00-1.80 arasındaki değerlerin “Hiç Katılmıyorum”, 1.81-2.60 arasındaki değerlerin “Katılmıyorum”, 2.61-3.40 arasındaki değerlerin “Kararsızım”, 3.41-4.20 arasındaki değerlerin “Katılıyorum” ve 4.21-5.00 arasındaki değerlerin “Tamamen Katılıyorum” derecesinde gerçekleştiği kabul edilmiştir. Düzeylerin yer aldığı bu aralıklar, seçenklere verilen en düşük değer olan 1 ile en yüksek değer olan 5 arasındaki seri genişliğinin seçenek (düzey) sayısına bölünmesi ile elde edilmiştir.

BULGULAR

Bu bölümde ortaöğretim öğrencilerinin fen bilimlerinde kullanılan birim ve sembollerini bilip bilmediklerini ve bu birimlerin kullanılmasına yönelik görüşlerinin bazı değişkenler açısından farklılık gösterip göstermediğini ortaya koyan bulgulara yer verilmiştir.

Ortaöğretim Öğrencilerinin Fen Bilimlerinde Kullanılan Birim ve Semboller ile İlgili Bilgi Düzeyleri

Ortaöğretim öğrencilerinin fen bilimlerinde kullanılan birim ve semboller ile ilgili bilgi düzeyleri Tablo 2’de verilmiştir.

Tablo 2. Ortaöğretim Öğrencilerinin Fen Bilimlerinde Kullanılan Birim ve Semboller ile İlgili Bilgi Düzeyleri

Madde	Doğru		Yanlış		
	f	%	f	%	
1	İnç, bir uzunluk birimidir.	257	72,6	97	27,4
2	Ons, bir kütle birimidir.	137	38,7	217	61,3
3	Bir kara mili 1,609km’dir.	256	72,3	98	27,7
4	Kilogram, tonun 1/10000’idir.	91	25,7	263	74,3
5	1 Saat, 6000 saniyedir.	71	20,1	283	79,9
6	Newton’un birimi $kg \cdot m/s^2$ dir.	196	55,4	158	44,6
7	SI birimlerinde basınç, Pascal ile tanımlanmıştır ve birimi N/m^2 dir.	244	68,9	110	31,1
8	1bar, 1×10^6 Pascal’a eşittir.	212	59,9	142	40,1
9	1L = $1 \times 10^3 m^3$ ‘tür.	186	52,5	168	47,5
10	SI birim sisteminde hız, m/s^2 ile ifade edilir.	172	48,6	182	51,4
11	Hızın birim zamandaki değişim miktarı olan ivmenin birimi, m/s^2 dir.	256	72,3	98	27,7
12	SI birim sisteminde yoğunluğun birimi, kg/m^3 dir.	143	40,4	211	59,6
13	Sıvıların akmaya karşı gösterdikleri direnç olarak bilinen viskozitenin birimi Pa/s dir.	177	50,0	177	50,0
14	Joule, bir enerji birimidir.	295	83,3	59	16,7
15	Bir kalori (cal) ortalama 4,1868joule’dür.	243	68,6	111	31,4
16	SI birim sisteminde gücün birimi watt’tır.	234	66,1	120	33,9
17	Watt’ın birimi joule/saat ‘tir.	213	60,2	141	39,8
18	Ohm, bir direnç birimidir.	276	78,0	78	22,0
19	SI birim sisteminde m^2/kg ifadesi, özgül hacim birimidir.	145	41,0	209	59,0
20	Avogadro sayısı kadar atom veya molekül içeren maddeye 1mol denir.	264	74,6	90	25,4
21	273,15 K sıcaklık, $0^\circ C$ ’ye eşdeğerdir.	212	59,9	142	40,1
22	Sıcaklık ölçüsü olarak mutlak sıfır sıcaklığı 0 Kelvin’e karşılık gelmektedir.	184	52,0	170	48,0
23	$0^\circ C$ sıcaklık, $32^\circ F$ ’a eşdeğerdir.	223	63,0	131	37,0
24	Özısı, ‘c ’ ile ifade edilir ve birimi $cal/g^\circ C$ dir.	276	78,0	78	22,0
25	Elektrik akımı birimi amperdir ve ‘A’ ile gösterilir.	279	78,8	75	21,2

Tablo 2’de görüldüğü üzere ortaöğretim öğrencilerinin fen bilimlerinde kullanılan birim ve sembollerini bilme durumları toplam frekans ve yüzde değerlerine göre değerlendirilmiştir. Buna göre genel olarak öğrencilerin sorulan birim ve sembollerini bildikleri söylenebilir. Lise ve üniversite öğrencileri ile ilgili olarak yapılan çalışmalarda da kimya derslerinde kullanılan birimlerin öğrenciler tarafından yeterince öğrenilmediğini göstermektedir (Yücel vd. 2001; Seçken vd. 2002; Yıldırım ve İlhan, 2007). Çalışmada elde edilen sonuçlarla çelişmektedir. Tablo 2’de görüldüğü üzere ortaöğretim öğrencilerinin 5 maddeye (2, 8, 9, 10, 17) vermeleri

gereken yanıtı vermedikleri görülmektedir. Bir madde de (13) öğrencilerin yarısı doğru yarısı yanlış yanıt vermişlerdir. 25 maddeden 19 madde de öğrencilerin belirttiği yanıtlar gerçek yanıtlardır. Buradan yola çıkarak, genel olarak ortaöğretim öğrencilerinin birim ve sembolleri bildiklerini söyleyebiliriz.

Ortaöğretim Öğrencilerinin Fen Bilimlerinde Kullanılan Birimlerin Kullanılmasına Yönelik Görüşleri

Ortaöğretim öğrencilerinin fen bilimlerinde kullanılan birimlerin kullanılmasına yönelik görüşleri Tablo3'te verilmiştir.

Tablo 3. Ortaöğretim Öğrencilerinin Fen Bilimlerinde Kullanılan Birimlerin Kullanılmasına Yönelik Görüşleri

Madde	Hiç Katılmıyorum		Katılmıyorum		Kararsızım		Katılıyorum		Tamamen Katılıyorum		\bar{X}
	f	%	f	%	f	%	f	%	f	%	
1	39	11,0	35	9,9	51	14,4	107	30,2	122	34,5	3,67
2	88	24,9	76	21,5	56	15,8	71	20,1	63	17,8	2,84
3	45	12,7	57	16,1	99	28,0	102	28,8	51	14,4	3,16
4	157	44,4	67	18,9	59	16,7	40	11,3	31	8,8	2,21
5	57	16,1	55	15,5	93	26,3	88	24,9	61	17,2	3,12
6	43	12,1	48	13,6	124	35,0	97	27,4	42	11,9	3,13
7	34	9,6	47	13,3	103	29,1	122	34,5	48	13,6	3,29
8	37	10,5	54	15,3	77	21,8	110	31,1	76	21,5	3,38
9	44	12,4	60	16,9	85	24,0	97	27,4	68	19,2	3,24
10	29	8,2	59	16,7	77	21,8	102	28,8	87	24,6	3,45
11	46	13,0	65	18,4	108	30,5	72	20,3	63	17,8	3,12

Tablo 3'te ortaöğretim öğrencilerinin fen bilimlerinde kullanılan birimlerinin kullanılmasına yönelik görüşlerini belirlemeye yönelik maddelere verdikleri yanıtların ortalama değerleri yer almaktadır. Buna göre öğrencilerin hiç katılmadıkları ve tamamen katıldıkları hiçbir madde olmamıştır. Öğrencilerin sadece 1 maddeye (4) katılmadıkları; 8 maddede (2, 3, 5, 6, 7, 8, 9, 11) kararsız oldukları ve 2 maddeye de (1, 10) katıldıkları görülmektedir. Yani öğrenciler sınavlarda birimlerden puan kesilmemesi gerektiğini (Yıldırım ve İlhan, 2007) ve birimleri doğru yazmaya çalışmanın soru çözümünde zaman kaybı yarattığını düşünmektedirler. Ancak yine de birimlerin belirtilmesinin önemli olduğunu vurgulamaktadırlar. Bu sonuç, öğrencilerin sürekli olarak süre ile yarıştıkları sınav sistemiyle ilişkilendirilebilir.

Ortaöğretim Öğrencilerinin, Fen Bilimleri Derslerinde Kullanılan Birim ve Sembollerin Kullanımına İlişkin Görüşlerinin Cinsiyet, Sınıf Düzeyi ve Okul Türüne Göre Farklaşma Durumu

Ortaöğretim öğrencilerinin, fen bilimleri derslerinde kullanılan birim ve sembollerin kullanımına ilişkin görüşlerinin cinsiyet, sınıf düzeyi ve okul türüne göre farklılaşma durumu Tablo 4 ve Tablo 5'te verilmiştir.

Tablo 4. Araştırmaya Katılan Öğrencilerin Fen Bilimlerinde Kullanılan Birimlerinin Kullanılmasına Yönelik Görüşlerinin Cinsiyet Değişkenine Göre Farklaşma Durumu (Mann-Whitney U Testi)

Madde	Kadın		Erkek		U (10 ⁴)	Z	p
	Sıra ort	Sıra top.	Sıra ort.	Sıra top.			
1	156,84	17095,50	186,69	45739,50	1,110	-2,633	,008
9	205,97	22450,50	164,83	40384,50	1,025	-3,579	,000

Tablo 4'de de görüldüğü üzere orta öğrencilerinin fen bilimlerinde kullanılan birimlere ilişkin görüşlerinin cinsiyete göre farklılaşma durumu verilmiştir. Buna göre iki maddede farklılaşma vardır. Ankette yer alan 1. maddeye "Birimlerin belirtilmesi önemlidir", erkeklerin daha fazla katıldıkları, 9. madde ise "Birimleri birbiriyle karıştırıyorum" kadınların daha fazla katıldıkları anlaşılmaktadır.

Araştırmaya katılan öğrencilerin fen bilimlerinde kullanılan birimlere yönelik görüşlerinin sınıf düzeyi değişkenine göre hiçbir maddede farklılaşmadığı görülmüştür. Herhangi bir maddede farklılaşma olmadığı için istatistiksel çözümlenmeye yer verilmemiştir.

Tablo 5. Araştırmaya Katılan Öğrencilerin Fen Bilimlerinde Kullanılan Birimlerinin Kullanılmasına Yönelik Görüşlerinin Okul Türü Değişkenine Göre Farklılaşma Durumu (Kruskal-Wallis Testi)

Madde	Anadolu	Meslek	Fen lisesi	Genel lise	df	X ²	p	Anl.Fark
	lisesi	lisesi	Sıra ortalamaları					
3	231,21	155,17	196,20	185,85	3	24,986	,000	M.Lise-*A.Lise
4	164,62	190,62	177,57	155,63	3	8,249	,041	G.Lise-*M.Lise
8	219,56	170,95	171,58	171,02	3	9,690	,021	G.Lise-*A.Lise

Tablo 5’te araştırmaya katılan öğrencilerin fen bilimlerinde kullanılan birimlere yönelik görüşlerinin okul türüne göre farklılaşma durumuna yer verilmiştir. Buna göre öğrenci görüşlerinin 3 maddede farklılaştığı görülmektedir. 3. maddede “Birimini bilmediğim kavramları formüllerinden çıkarabiliyorum” maddesinde Anadolu lisesi ile meslek lisesi öğrencileri arasında Anadolu lisesi öğrencileri lehine anlamlı bir fark vardır. Bu sonu Anadolu lisesi öğrencilerinin daha iyi çıkarsama yapabildikleri biçiminde yorumlanabilir. 4. madde olan “Sınavlarda birimlerden puan kırılması gerektiğini düşünüyorum” maddesine ise genel lisedeki öğrencilerin meslek lisesindeki öğrencilerine oranla daha az katıldıkları görülmektedir. Bu da genel lise öğrencilerinin daha çok çözüme odaklandığı, çözüme giden yola pek önem vermedikleri biçiminde yorumlanabilir. “Birimleri bilmesem de doğru sonuca ulaşabilirim” (8. madde) maddesinde ise her iki lise türünün ortalama puanlarının birbirine çok yakın olmasına rağmen farkın Anadolu lisesi öğrencileri lehine olduğu görülmektedir.

SONUÇ

Ortaöğretim öğrencilerinin fen bilimlerinde kullanılan söz konusu birim ve sembolleri bilip bilmediklerinin belirlenmesi ve bu birimlerin kullanılmasına yönelik görüşlerinin bazı değişkenler açısından farklılık gösterip göstermediğinin belirlenmesi amaçlanan araştırmanın bulguları genel olarak değerlendirildiğinde aşağıdaki sonuçlar elde edilmiştir:

- Genel olarak öğrencilerin fen bilimleri derslerinde kullanılan birim ve sembolleri bildikleri görülmektedir.
- Ortaöğretim öğrencileri birim ve sembollerin kullanımının önemli olduğunu bildiklerini fakat soru çözümlerinde birim yazmanın zaman kaybına neden olduğunu ve buna bağlı olarak birim yazmadıkları için puan kırılmaması gerektiğini belirtmektedir.
- Erkek öğrenciler, birimlerin belirtilmesini kadın öğrencilere göre daha fazla önemsemektedirler.
- Kadın öğrenciler erkek öğrencilere göre birimleri daha fazla karıştırmaktadır.
- Öğrencilerin fen bilimlerinde kullanılan birimlere yönelik görüşleri sınıf değişkenine göre farklılaşmamaktadır.
- Anadolu lisesinde öğrenim gören öğrenciler, birimini bilmedikleri kavramları formüllerinden çıkartabilmektedirler.
- Genel lise öğrencileri birimlerden puan kesilmemesi gerektiğini düşünmektedirler.
- Anadolu Lisesi öğrencileri birimleri bilmeden de doğru sonuca ulaşabileceklerini belirtmektedirler.

KAYNAKLAR

- Cohen, L., Manion, L., & Morrison, K. (2000). *Research Methods in Education*. New York: Routledge.
- Karasar, N. (2013). *Bilimsel Araştırma Yöntemi*. (25. Baskı) Ankara: Nobel Yayıncılık.
- Seçken N., Yücel S. ve Morgil F.İ. (2002). Yükseköğretimde bazı kimya bilgilerinin sınıf düzeyi ve cinsiyete göre dağılımı. *Boğaziçi Üniversitesi Eğitim Dergisi*, 19(2), 1-14.
- Tezbaşaran, A. (1997). *Likert tipi ölçek geliştirme*. Ankara: Psikologlar Derneği Yayınları.
- Yalçın, A.(2001). Birim Sistemleri. *Bilim ve Teknik*, Temmuz, 72-74.
- Yıldırım, A., & İlhan, N. (2007). Lise Öğrencilerinin Kimya Dersinde Öğretilen Birimler Hakkındaki Görüşleri ve Deneyimleri. *Gazi University Journal of Gazi Educational Faculty (GUJGEF)*, (3).
- Yücel S., Seçken N., ve Morgil F.İ. (2001). Öğrencilerin lise kimya derslerinde öğretilen semboller, sabitler ve birimlerini öğrenme derecelerinin ölçülmesi. *Gazi Üniversitesi Gazi Eğitim Fakültesi Dergisi*, 21 (2), 113-123.

PRE-SERVICE SCIENCE TEACHERS' IMAGES OF PHYSICIST AND PHYSICS COURSE

Emine ÇİL
Muğla Sıtkı Koçman University
emineonyedi@hotmail.com

Durmuş YANMAZ
Muğla Sıtkı Koçman University
durmusyalmaz@mu.edu.tr

Seda ŞAHİN AKYÜZ
Muğla Sıtkı Koçman University
sedas-14@hotmail.com

Funda Gül İRİ
Muğla Sıtkı Koçman University
fndaglr3409@hotmail.com

Hazel KAR
Muğla Sıtkı Koçman University
heyzilk988@hotmail.com

ABSTRACT: The aim of this study is to investigate the pre-service science teachers' images of physicist and physics course. A total of 69 students, who were studying in primary science teaching at the Education Faculty of Muğla Sıtkı Koçman University in Turkey. The data were collected using Word Association Test. Response words with the same meaning were classified under the most frequently repeated words. Words less than two times and those words that could not be associated were considered as irrelevant and were excluded. After contents have been analyzed, the frequency of the response words has been calculated and categorized. Participants' associations of the term physicist were arranged into four categories. Participants' associations of the term physics course were arranged into six categories. According to results, most of the participants related to personal character of physicist. More than half of the participants' images are that physics course is difficult and most of them have negative attitudes towards physics course.

Key words: physicist, physics course, image, word association test

INTRODUCTION

Physics help us to understand most of the facts/phenomenon/events in real life. Additionally, individuals can gain scientific thinking abilities through physics education. This is mainly based on the interactions and communications which take place between physicist and students. On the other hand, instructor's qualifications for physics course are so important that learning physics is accepted difficult by some of the researcher (Lederman, 1993). Physicist's characteristics, including the actions and behaviors from the beginning till the end of the lesson can affect the students' perspectives about physicist and physics course. Therefore it is essential to understand how students' perceive physicist and physics course. Students' images of physicist and physics course can inform us how students see them and what they sense about them. The aim of this study is to investigate the pre-service science teachers' images of physicist and physics course.

METHODS

Participants

A total of 69 students, who were studying in primary science teaching at the Education Faculty of Muğla Sıtkı Koçman University in Turkey, participated in this study. They were in first year in their teacher training program. The majority of the participants were female (%89.8). This study was conducted during September 2013.

Data Collection

Participants were asked to complete a word association test (WAT). The word association test is a data collection technique which is reported in the literature to be used to investigate a person's or a group's conceptual field or image on a particular subject. In its simplest form one or a series of stimulus words projected orally or written to the participants who must respond with the first word(s) that come(s) to their mind (response words) (Daskolia, Flogaitis, & Papageorgiou, 2006). In the test, the terms "physicist" and "physics course" were presented as a stimulus in the following format:

Physicist:
Physicist:
Physicist:
Physicist:
Physicist:
Related Sentence:.....

The reason for writing the term stimulus five times, one under the other, is to prevent the risk of chain responses. If the teacher does not return to the stimulus term after writing one response, he or she will tend to write words associated with the previous response word that he or she wrote instead of the stimulus word. This situation could be detrimental to the purpose of the test. Teachers were asked to write the first five words that came to their mind when hearing or reading terms "physicist" and "physics course." The technique is based on the assumption that providing a stimulus word and asking respondents to freely associate the ideas which come to mind gives relatively unrestricted access to mental representations of the stimulus term (Bahar, Johnstone, & Sutcliffe, 1999; Sato & James, 1999). During the implementation, the participants were provided with necessary explanation. In the first stage, they were given 40 seconds for writing responses (Gussarsky & Gorodetsky, 1990) In the second stage, participants were also expected to write down a sentence related to the key concepts in 20 seconds.

Data Analysis

Data collected from word association test were analyzed by authors. Response words with the same meaning were classified under the most often repeated words. Words less than two times and those words that could not be associated were considered as irrelevant and were excluded. After contents have been analyzed, the frequency of the response words has been calculated and categorized. Related sentences were individually examined during the data analysis to determine participants' images of physicist and physics course. Many studies have shown this type of data analysis technique provides reliable results (Daskolia et al., 2006; Torkar & Bajd, 2006).

RESULTS AND FINDINGS

The data collected from responses regarding the word association test are submitted in two separate sections. They are pre-service science teachers' images of physicist and physics course.

Pre-Service Science Teachers' Images of Physicist

Participants' associations of the term physicist were a total of 315. A total of 17 (5%) of these associations could not be categorized. These words appeared once and could not be categorized with the other words. Inferentially, they were excluded from the results in Table 1. The remaining 34 different associations were divided into four categories. These categories, response words and their frequency are listed in Table 1.

According to the results, the associations related to personal character of physicist create the dominant category ($f= 234$). In this category some of the participants produced positive associations, such as *intelligent*, *industrious*, *disciplined*, *successful* and *patient* related to physicist. However, some of the participants produced negative associations, such as *nervous*, *boring*, *compelling* and *scary*. When participants' sentences are examined about physicist, it is seen that the sentences were in parallel with findings of stimulus term. For example: "Physicists are very intelligent people." (Student 1), "Physicists are always industrious." (Student 2).

In the second category, participants produced associations related to activities of physicist ($f= 50$). In this category, most of the participants focused on *experiment*, *researcher*, *calculation* and *comment*. For example related sentence about this category: "Physicist is a person who likes to experiment and research" (Student 3).

In the third category, participants focused on the physical character of the physicist ($f= 10$). Accordingly, the participants consider the physicist as a person with *bespectacled*, *female* and *fat*.

In the fourth category, the participants produced associations related to careers of the physicist ($f= 9$), such as *teacher* and *professor*.

Table 1. Associations With The Term Physicist

Categories	Associations Included in Categories and Their Frequencies	Total Frequency of Associations in This Category	%
Personal Character of Physicist	Intelligent (31)	234	79
	Interesting (25)		
	Boring (23)		
	Nervous (20)		
	Compelling (19)		
	Disciplined (15)		
	Industrious (12)		
	Scary (11)		
	Successful (9)		
	Uninformed (8)		
	Funny (7)		
	Calm (7)		
	Patient (6)		
	Well (6)		
	Curious (5)		
	Careful (5)		
	Logical (5)		
	Active (5)		
	Talkative (4)		
	Thoughtful (4)		
Cute (4)			
Confident (3)			
Activities of Physicist	Experiment (11)	45	15
	Responsive to the needs (10)		
	Researcher (8)		
	Comment (5)		
	Dealing with physics (5)		
	Calculation (4)		
	Observation (2)		
Physical Character of Physicist	Bespectacled (4)	10	3
	Female (4)		
	Fat (2)		
Careers of Physicist	Teacher (6)	9	3
	Professor (3)		

Pre-Service Science Teachers' Images of Physics Course

Participants' associations of the term physics course were a total of 345. A total of 58 (17%) of these associations could not be categorized. These words appeared once and could not be aggregated with other words. Finally, they were excluded from the results. The remaining 29 different associations were divided into six categories. These categories, response words and their frequency are listed in Table 2.

According to the results, the associations related to qualifications of the physics course create the dominant category, ($f= 180$). In this category, it is observed that many of the participants focused on the *difficult*, *boring*, *enjoyable* and *tiring*. When participants' related sentences are examined about physics course, it is seen that the sentences were in parallel with findings of stimulus term. For example: "Physics course is the most difficult course among science courses" (Student 4), "Generally physics course is a theoretical course, so it is boring" (Student 5).

In the second category, the participants produced associations related to requires to be successful in the physics course ($f= 34$). In this category, many of the participants believed to need *decided*, *thinking*, *patient* and *attentive*. For example related sentence about this category: "Physics course is difficult and complicated. If you are patient during the lesson, you can be successful" (Student 6).

In the third category, the participants focused, in general, on activities in physics course, such as *using formula, calculate* and *experiment* (f= 34).

The fourth category reflects the associations of participants' attitudes towards physics course (f= 29). In this category most of the participants produced negative associations, such as *dislike, unnecessary* and *belief for unsuccessful*. However some of the participants produced positive associations *necessary* and *excitement*. For example related sentences about this category: "I'm afraid that if I can not pass the physics course" (Student 7), "Actually I like physics course. It is interesting. But this situation can be change according to the teacher" (Student 8).

In the fifth category, the participants associated with environments of physics course, such as *laboratory* and *classroom* (f= 6). For example related sentence about this category: "We wear white laboratory coat in the laboratory" (Student 9).

In the six category, the participants have produced associations related to content of physics course (f= 13). Most of the participants in this category focused on *force and motion*.

Table 2. Associations With The Term Physics Course

Categories	Associations Included in Categories and Their Frequencies	Total Frequency of Associations in This Category	%
Qualifications of the Physics Course	Difficult (50)	180	63
	Boring (37)		
	Enjoyable (32)		
	Tiring (12)		
	Not understandable (11)		
	Curious (8)		
	Easy (8)		
	Complex (7)		
	Interesting (5)		
	Easily forgotten (3)		
	Fastmoving (3)		
	Understandable (2)		
Requires to be successful in the Physics Course	Detailed (2)	34	12
	Decided (17)		
	Thinking (9)		
	Patient (4)		
Activities in Physics Course	Attentive (4)	34	12
	Using Formula (13)		
	Calculate (11)		
	Experiment (6)		
Attitudes toward the Physics Course	Observation (4)	29	10
	Dislike (13)		
	Unnecessary (5)		
	Belief for Unsuccessful (5)		
Environments of Physics Course	Excitement (3)	6	2
	Necessary (3)		
Content of Physics Course	Classroom (4)	4	1
	Laboratory (2)		
	Force and Motion (4)		

CONCLUSION

A general feature of pre-service science teachers' images for physicist is about personal character of him/her. Dikmenli (2010) investigated undergraduate biology students' images of science and scientist. His study revealed that participants focused on personal character of scientist. Physicist is thought intelligent or interesting person by some of the participants. However, some of the participants have negative associations for physicist like boring, nervous and scary. Such kinds of negative images for scientist have been revealed in previous studies (Finson, 2002; Bovina & Dragul'skaia, 2008). Also, some of the participants focused on activities of the physicist, such as experiment, responsive to the needs and researcher.

Participants' dominant category for physics course is qualifications of physics course. Negative associations for this category are difficult, boring, tiring, not understandable, complex and easily forgotten. A widespread opinion in the literature is that physics is a difficult course for most of the students; furthermore physics is a course which students have prejudice and fears to be unsuccessful (Angell, Guttersrud, Henriksen, & Isnes, 2004; Carlone, 2003; Korur & Eryilmaz, 2009; Osborne & Collins, 2001). Positive associations for this category are enjoyable, curious, easy, interesting, fastmoving, understandable and detailed. Another conclusion of this study, participants generally have negative attitudes toward physics course.

RECOMMENDATIONS

In this study, it was revealed that pre-service science teachers produce both negative and positive associations, regarding physicist and physics course. However, negative associations are more than positive associations. Because of these negative images are products of secondary school physics course, physics teaching can be revised in these schools. In the teacher training program, physics instructors should be aware of pre-service science teachers' negative images of physics course and physicist. Because of these negative associations can affect participants' physics success and their science teaching in the future. Physics and physics laboratory courses should support pre-service science teachers' improving positive images.

REFERENCES

- Angell, C., Guttersrud, Ø., Henriksen, E.K., & Isnes, A. (2004). Physics: Frightful, But Fun. *Science Education*, 88, 683-706.
- Bahar, M., Johnstone, A.H. & Sutcliffe, R.G. (1999). Investigation of students' cognitive structure in elementary genetics through word association tests. *Journal of Biological Education*, 33(3), 134-141.
- Carlone, H.B. (2003). Innovative science within and against a culture of "achievement". *Science Education*, 87, 307-328.
- Daskolia, M., Flogaitis, E. & Papageorgiou, E. (2006). Kindergarten teachers' conceptual framework on the ozone layer depletion. Exploring the associative meanings of a global environmental issue. *Journal of Science Education and Technology*, 15(2), 168-178.
- Gussarsky, E. & Gorodetsky, M. (1990). On the Concept On the Concept "Chemical Equilibrium: The Associative Framework. *Journal of Research in Science Teaching*, 27(3), 197-204.
- Korur, F. (2001). The Effects of Teachers Characteristics on High School Students' Physics Achievement, Motivation and Attitudes. *Unpublished Master Thesis*, Middle East Technical University, Ankara, Turkey.
- Korur, F. & Eryilmaz, A. (2009). High School Students' Perceptions about Effects of Teachers' Characteristics on Their Physics Achievement. *Gazi Eğitim Fakültesi Dergisi*, 29(3), 733-761.
- Lederman, N.G. (1993). Introduction: Summary of research in science education. *Science Education*, 77, 465-559.
- Osborne, J., Collins, S. (2001). Pupils' views of the role and value of science curriculum: A focus-group study. *International Journal of Science Education*, 23(5), 441-467.
- Sato, M. & James, P. (1999). "Nature" and "environment" as perceived by university students and their supervisors. *International Journal of Environmental Education and Information*, 18(2), 165-172.
- Torkar, G. & Bajd, B. (2006). Trainee teachers' ideas about endangered birds. *Journal of Biological Education*, 41(1), 5-8.

MATEMATİK ÖĞRETMEN ADAYLARININ ÇİN KALAN TEOREMİ İLE İLGİLİ SOYUTLAMAYI İNDİRGEME EĞİLİMLERİ

PRE-SERVICE MATHEMATICS TEACHERS TENDENCIES OF REDUCING ABSTRACTION ABOUT CHINESE REMAINDER THEOREM

Ş. Can ŞENAY
KTO Karatay Üniversitesi
sabancan.senay@karatay.edu.tr

Ahmet Ş. Özdemir
Marmara Üniversitesi
ahmet.ozdemir@marmara.edu.tr

ÖZET: Matematik öğretmen adaylarının lisans eğitimi süresince alan bilgilerinin şekillenmesinde önemli rolü olan derslerden birisi de Sayılar Teorisi dersi. Bu çalışmada, matematik öğretmen adaylarının, Sayılar Teorisi dersinde verilen Çin kalan teoremi ile ilgili algılayışları, Hazzan'ın (1999) geliştirdiği *soyutlamanın indirgenmesi* teorisi çerçevesinde incelenmiştir. *Soyutlamanın indirgenmesi* düşüncesi, öğrencilerin bir derste karşılaştıkları kavramlardaki soyutlamadan veya uzmanların (matematikçiler, öğretmenler vb.) kendilerinden beklediğinden daha düşük seviyedeki bir soyutlamayla çalışma eğilimlerine dayanmaktadır. Araştırmamızda, ilköğretim ve ortaöğretim matematik eğitimi bölümlerinde okuyan öğretmen adaylarından oluşan bir çalışma grubuyla yapılan geniş kapsamlı bir araştırma kapsamında sorulan Çin kalan teoreminin uygulamasına yönelik bir probleme verilen cevaplar, betimsel analiz ve içerik analizi yöntemleri ile incelenmiştir. Elde edilen bulgulardan, öğretmen adaylarının birçoğunun, problemin çözümünde ortaokul veya lisede öğrendikleri yöntemi kullandıkları veya teoremi hipotezlerini kontrol etmeden bir formül gibi kullandıkları görülmüştür. Öğretmen adaylarının bu şekildeki yaklaşımları soyutlama seviyesinin indirgenmiş olduğunu bir göstergesidir.

Anahtar sözcükler: Soyutlamanın indirgenmesi, Çin kalan teoremi.

ABSTRACT: Number Theory is one of the courses that plays an important role in forming the content knowledge of the pre-service mathematics teachers during their undergraduate education. In this research, the conception of the pre-service mathematics teachers about the Chinese remainder theorem which is given in the Number Theory course is examined through the lens of the theoretical framework of *reducing abstraction* (Hazzan, 1999). The answers of a study group to a question related with the Chinese remainder theorem which is in the scope of a wider research are analyzed with the methods of content and descriptive analysis. From the obtained findings, it was observed that many of the pre-service teachers used the method that they had learned at high school to solve the question or they used the theorem like a formula without checking the hypothesis of the theorem. This situation is an indication that the level of abstraction is reduced.

Key words: Reducing abstraction, Chinese remainder theorem.

GİRİŞ

Bireylerin matematiği iyi öğrenmesini etkileyen en önemli faktörlerden birisi de öğretmenlerdir. Öğretmenlerin bilgi ve yeterlikleri, matematik eğitiminin kalitesiyle doğrudan alakalıdır. Shulman'ın (1987) bir öğretmenin sahip olması gereken bilgi ve yeterlikler kapsamında tanımladığı alan bilgisi, öğretmenin alanındaki kavram ve olgular bilgisi ve alanın yapısı hakkındaki bilgisini kapsar. Sayılar teorisi de matematik öğretmen adaylarının lisans eğitimi süresince alan bilgilerini şekillendiren en önemli derslerden birisidir. Sayılar teorisi, formel ve bilişsel doğası, aritmetik ve cebirle ilişkisi, kriptoloji ve bilgisayar bilimleri gibi birçok uygulama alanı ile matematik eğitiminde üzerinde özellikle durulması gereken bir alandır. Matematik tarihi ve felsefesindeki rolü ve öğretmenlerin alan bilgisindeki önemine rağmen sayılar teorisine yakın zamana kadar matematik eğitimi araştırmalarında kısıtlı yer verilmiştir (Zaskis ve Campbell, 2011). Bununla birlikte araştırmamızın teorik çerçevesini oluşturan *soyutlamanın indirgenmesi teorisi* de öğrencilerin lisans matematiğindeki kavramlarını açıklamak ve soyutlama seviyelerini incelemek için geliştirilmiş olmasına rağmen sayılar teorisi alanında derinlemesine kullanılmamıştır.

Soyutlamamın İndirgenmesi

Soyutlama seviyesinin indirgenmesi (kısaca, *soyutlamamın indirgenmesi*) teorisi, ilk olarak Hazzan (1999) tarafından, lisans öğrencilerinin soyut cebir kavramlarını algılayışlarını açıklamak için geliştirilerek kullanılmış ve genellikle de ileri matematiksel düşünceyle ilgili alanlar (bilgisayar bilimleri gibi) ve lisans matematiğindeki konularla ilişkilendirilmiş (Hazzan, 2001, 2003a, 2003b) bir teoridir. Hazzan ve Zaskis (2005) ise bu teorisin okul (ilk ve orta öğretim) matematiği seviyesinde de kullanılabileceğini göstermişlerdir. *Soyutlama seviyesinin indirgenmesi* düşüncesi esasen öğrencilerin, derste karşılaştıkları kavramlardaki soyutlamadan veya uzmanların (matematikçiler, öğretmenler vb.) kendilerinden beklediğinden daha düşük seviyedeki bir soyutlamayla çalışma eğilimlerine dayandırılabilir. “Soyutlamamın indirgenmesi” terimi mutlaka yanılıyla veya matematiksel hatayla sonuçlanan bir zihinsel süreç olarak anlaşılmalıdır. Soyutlama seviyesini indirgeme süreci, öğrencinin öğrendiği yeni kavramlarla baş edebilmek için yollar bulmasının göstergesidir. Öğrenciler bu şekilde, kavramları zihinsel olarak erişilebilir hale getirir böylece onlarla düşünebilir ve bilişsel olarak ele alabilirler. Soyutlamamın indirgenmesi teorisi, literatürdeki *soyutlama seviyeleri* ile ilgili üç farklı yorumdan hareketle oluşturulmuştur. Bununla birlikte, soyutlama seviyelerinin bu farklı yorumlarının birbirlerini karşılıklı olarak ne tamamen dışladıklarını ne de tamamen kapsadıklarını da ayrıca belirtmeliyiz (Hazzan, 1999, 2001). Aşağıda, soyutlama seviyelerinin bu üç farklı yorumu ile ilgili bilgi verilecektir.

a) Düşünülen nesne ve düşünen insan arasındaki ilişkinin kalitesi bakımından soyutlama seviyesi

Soyutlama seviyesi ile ilgili bu yorum, Wilensky’ nin (1991), “herhangi bir şeyin soyut ya da somut olması, o şeyin doğal bir özelliği değildir aksine kişi ile nesne arasındaki ilişkinin özelliğinden kaynaklanır” iddiasına dayanır. Başka bir deyişle, her kavram ve her kişi için ikisi arasındaki önceki ilişkiyi yansıtan farklı bir seviyedeki soyutlamayı gözleyebiliriz. Bir kişi bir nesneye ne kadar yakın olursa ve ne kadar çok bağ kurmuşsa bu nesneyi o kadar daha somut (ve daha az soyut) hisseder. Bu bakış açısının temelinde, bazı öğrencilerin zihinsel süreçlerindeki, tanıdık olmayan bir düşünceyi daha tanıdık yapma veya soyutu somut yapma eğilimleri yatmaktadır (Hazzan, 1999).

b) Süreç-nesne ikililiğinin (*process-object duality*) yansıması bakımından soyutlama seviyesi

Soyutlama seviyesi ile ilgili bu yorum, matematik eğitiminde kavram geliştirme teorilerinde önerilen süreç-nesne ikililiğine dayanır. Bu ikililiğe dayanan teoriler (*APOS* teorisi gibi), matematiksel düşüncelerin, süreç olarak kavranışı ile nesne olarak kavranışını birbirinden ayırırlar ve farklılıklarına rağmen matematiksel bir kavram öğrenildiğinde, onun bir süreç (ardışık işlemler) olarak kavranmasının nesne olarak kavranmasından önce ve daha az soyut olduğu üzerinde birleşirler. Bundan dolayı matematiksel bir kavramın süreç olarak kavranışı bir nesne olarak kavranışından daha düşük bir seviyede soyutlama (yani *soyutlamamın indirgenmesi*) olarak yorumlanabilir (Hazzan, 1999).

c) Düşünülen matematiksel kavramın karmaşıklığının derecesi bakımından soyutlama seviyesi

Soyutlama seviyesinin bu yorumunu bir örnekle açıklamak gerekirse; elemanların bir kümesi, kümedeki herhangi bir özel elemandan daha karmaşık bir matematiksel yapıdır. Bu gerçek tabii ki de karmaşık nesnelere düşünmenin daha zor olacağını gerektirmez. Buradaki varsayımımız, bir yapı ne kadar karmaşık o kadar da soyuttur çünkü bir yapı bütün olarak analiz edildiğinde daha fazla detay göz ardı edilmelidir. Bu bakımdan soyutlamamın bu yorumu, öğrencilerin, bir kümenin yerine onun bir elemanını koyarak dolayısıyla da daha az karmaşık bir nesneyle çalışarak soyutlama seviyesini nasıl indirdiklerine odaklanmaktadır.

Çin Kalan Teoremi

Kalanlarla ilgili en eski problemin, M.S. üçüncü yüzyılda yazıldığı kabul edilen *Sun Zi Suanjing* adlı bir matematik eserinde olduğu keşfedilmiştir. Bundan dolayı kalan problemi günümüzde Çin kalan teoremi olarak bilinmektedir. *Sun Zi Suanjing*’deki problem şu şekildedir: “ Bir sayı 3’e bölündüğünde 2 kalıyor, 5’e bölündüğünde 3 kalıyor, 7’ye bölündüğünde de 2 kalıyor. Bu sayı kaçtır?”. Eski çağlardan günümüze kadar kalan problemi ile ilgili birçok çalışmalar yapılmış ve teorem geliştirilerek günümüzdeki halini almıştır (Ing, 2003). Çin kalan teoremi özellikle bilgisayar bilimleri ve kriptolojide yaygın olarak kullanılmaktadır.

Çin Kalan Teoremi: m_1, m_2, \dots, m_r sayıları karşılıklı aralarında asal olan r tane pozitif tamsayı, $a_1, a_2, \dots, a_r \in Z$ olsun. Bu durumda,

$$x \equiv a_1 \pmod{m_1}$$

$$x \equiv a_2 \pmod{m_2}$$

$$\dots\dots\dots$$

$$x \equiv a_r \pmod{m_r}$$

sisteminin ortak çözümleri vardır. Ayrıca m_1, m_2, \dots, m_r modülüne göre bu sistemin bir tek çözümü vardır (Şenay, 2007, s.151).

Araştırmamızın amacı, öğretmen adaylarının Sayılar Teorisi dersinde gördükleri ve ispatı kongrüans sistemlerinin çözümleri için bir metot oluşturan Çin kalan teoremi ile ilgili soyutlamayı indirgeme seviye ve eğilimlerini belirlemektir. Bu amaç doğrultusunda problem cümlesi, “ Matematik öğretmen adaylarının Çin kalan teoremi ile ilgili soyutlamayı indirgeme eğilimleri nelerdir?” şeklinde belirlenmiştir.

YÖNTEM

Bu bölümde, araştırmanın modeli, çalışma grubu, veri toplama aracı, verilerin toplanması ve verilerin analizi ile ilgili açıklamalar yapılacaktır.

Araştırmanın Modeli

Araştırmamızın odağını, elde edilen verilerin belirli bir teorik çerçevede yorumlanması oluşturduğu için çalışmamızda yorumlayıcı örnek olay incelemesi modeli kullanılmıştır. Yorumlayıcı örnek olay incelemeleri, toplanan verilerle, özellikle bir kuram geliştirilmesine veya bir kuramın test edilmesine uygun bir modeldir (Akar Vural ve Cenkseven, 2005).

Çalışma Grubu

Bu araştırma, 2012-2013 güz döneminde, N. Erbakan Üniversitesi A. K. Eğitim Fakültesinin İlköğretim Matematik Öğretmenliği ve Ortaöğretim Matematik Öğretmenliği Bölümlerinde okuyan 136 öğretmen adayı üzerinde yürütülmüştür. Araştırmamızda, matematik öğretmen adaylarının Sayılar Teorisi dersi kapsamındaki Çin kalan teoremi ile ilgili soyutlamayı indirgeme eğilimleri inceleneceği için çalışma grubu, Sayılar Teorisi dersini almış veya almakta olan öğretmen adaylarından oluşturulmuştur.

Verilerin Toplanması ve Analizi

Çalışma grubundaki öğretmen adaylarına Çin kalan teoreminin uygulamasına yönelik aşağıdaki problem sorulmuştur.

Soru. Bir çoban koyunlarını 5'er saydığında 2, 7'şer saydığında 4, 9'ar saydığında 6 koyun artmaktadır. Buna göre çobanın en az kaç koyunu vardır?

Soruya verilen yazılı cevaplar, teorik çerçeveye uygun olarak betimsel analiz ve içerik analizi yöntemleri ile incelenmiştir.

BULGULAR ve YORUMLAR

Öğretmen adaylarından 33'ü (% 24.3), Çin kalan teoremini tam ve doğru bir şekilde kullanarak problemin çözümünü yapmıştır. 101 (% 74.3) öğretmen adayı soyutlama seviyesini indirgememiş, bunlardan 79'u (%58.1) ise soyutlamayı indirgeyerek doğru cevaba ulaşmıştır. Öğretmen adaylarından 66'sı (% 48.5) sorunun çözümünde ortaokul veya lisede öğrendikleri yöntemi kullanmışlardır. Şekil 1.' de bir öğretmen adayının bu yöntemle yaptığı çözüm örnek olarak verilmiştir.

$$\begin{aligned} 5x+2 &= 7y+4 = 9z+6 = T \\ +3 & \quad +3 \quad +3 \\ 5x+5 &= 7y+7 = 9z+9 = T+3 \\ [5,7,9] &= 315 \\ T+3 &= 315 \\ T &= 312 \text{ koyun} \end{aligned}$$

Şekil 1. Bir Öğretmen Adayının Soruyu Çözümü

Şekil 1.' deki ve benzer çözümleri yapan öğretmen adayları, Çin kalan teoremini kullanmak yerine kendilerine daha tanıdık gelen ve önceden alışık oldukları bir metodu kullanarak soyutu daha somut yapma eğilimi göstermişler ve *düşünülen nesne ve düşünen insan arasındaki ilişkinin kalitesi bakımından* soyutlama seviyesini indirgemişlerdir. Bu öğretmen adaylarının, soruda istenenin, aslında bir kongrüans sisteminin çözümü olduğunu analiz etmeden yani kavramı *nesne* olarak göz önüne almadan, soruyla otomatik olarak tetiklenen *yönteme*

(süreç) yönelerek aynı zamanda süreç-nesne ikililiğinin yansıması bakımından da soyutlama seviyesini indirgediklerini söyleyebiliriz. Hazzan (1999) bu yaklaşımı, matematiksel bir kavramın süreç olarak kavranışının, öğrencinin doğal yöntemlere (*canonical procedure*) eğiliminin bir yansıması olarak açıklamaktadır. Doğal yöntemle aslında az veya çok sorulan soruyla otomatik olarak tetiklenen yöntem kastedilmektedir. Bu eğilim, problemin doğasının gereği oluşabileceği gibi, öğrencinin daha önce karşılaştığı benzer bir probleme uygulanan yöntemle ilişki kurmasının bir sonucu olarak da oluşabilir. Doğal yöntemler, matematiksel kavramların özelliklerinin analizi yapılmadan yani kavram nesne (*object*) olarak göz önüne alınmadan problemin çözülmesine fırsat verdiğinden öğrenciler tarafından daha çok tercih edilmektedir.

Öğretmen adaylarından 15'i (% 11), sorunun çözümünde Çin kalan teoremini kullandıklarını belirtmelerine rağmen teoremin teknik gösterimleri yerine kendilerinin alışık olduğu veya kendilerine daha tanıdık gelen gösterimleri kullanmışlardır. Şekil 2.' de bir öğretmen adayının kendi gösterimlerini kullanarak yaptığı çözüm örnek olarak verilmiştir.

$$\begin{aligned}
 x &= 2 (5) \\
 x &= 4 (7) \\
 x &= 6 (9)
 \end{aligned}$$

5, 7, 9 sayıları birbirine göre asal olduğundan Çin kalan Teoremini hesaplarız.

$$M = (5, 7, 9) = 315$$

$$\begin{aligned}
 x &= 5k + 2 & x + 3 &= 5k + 5 \\
 x &= 7m + 4 & x + 3 &= 7m + 7 \\
 x &= 9n + 6 & x + 3 &= 9n + 9
 \end{aligned}$$

$$\begin{aligned}
 x + 3 &= 5(k+1) = 7(m+1) = 9(n+1) \\
 x + 3 &= [5, 7, 9] \\
 x + 3 &= 315 \\
 x &= 312
 \end{aligned}$$

Şekil 2. Bir Öğretmen Adayının Soruyu Çözümü

Şekil 2.' deki ve benzer gösterimleri kullanan öğretmen adayları, tanıdık olmayana tanıdık yapma eğilimi göstererek soyutlama seviyesini *düşünülen nesne ve düşünen insan arasındaki ilişkinin kalitesi bakımından* indirgemişlerdir. Bu öğretmen adaylarının aynı zamanda, formel ifadeleri kişiselleştirerek yani *birinci şahıs dilini* kullanarak, soyutlama seviyesini *süreç-nesne ikililiğinin yansıması bakımından* da indirgediklerini söyleyebiliriz.

Birinci dereceden bir kongrüans sisteminin çözümünde Çin kalan teoreminin kullanılabilmesi için sistemdeki modüllerin karşılıklı olarak aralarında asal olması gereklidir. Fakat öğretmen adaylarından 16'sı (% 11.8) bu durumu göz ardı ederek teoremi kullanmışlardır. Şekil 3.' de bir öğretmen adayının bu şekilde yaptığı çözüm örnek olarak verilmiştir.

$$\begin{aligned}
 x &= 2 (5) \\
 x &= 4 (7) \\
 x &= 6 (9)
 \end{aligned}$$

$$M = 5 \cdot 7 \cdot 9 = 315$$

$$\begin{aligned}
 m_1 &= \frac{315}{5} = 63 & 63 \cdot x &\equiv 1 \pmod{5} & x &\equiv 2 \pmod{5} & x_1 &= 2 \\
 m_2 &= \frac{315}{7} = 45 & 45 \cdot x &\equiv 1 \pmod{7} & x &\equiv 5 \pmod{7} & x_2 &= 5 \\
 m_3 &= \frac{315}{9} = 35 & 35 \cdot x &\equiv 1 \pmod{9} & x &\equiv 8 \pmod{9} & x_3 &= 8
 \end{aligned}$$

$$\begin{aligned}
 x &= \sum_{i=1}^3 M_i \cdot a_i \cdot x_i = 63 \cdot 2 \cdot 2 + 45 \cdot 5 \cdot 4 + 35 \cdot 8 \cdot 6 \\
 &= 252 + 900 + 1680 \\
 x &= 2832
 \end{aligned}$$

$$\begin{aligned}
 x &\equiv 2832 \pmod{315} \Rightarrow x \equiv 312 \pmod{315} \\
 x_k &= 312 + 315t \quad t \in \mathbb{Z}
 \end{aligned}$$

Şekil 3. Bir Öğretmen Adayının Soruyu Çözümü

Şekil 3.' deki ve benzer çözümleri yapan öğretmen adayları, bir teoremin geçerli olabilmesi için hipotez(ler)inin sağlanması gerektiğini düşünmemiş ve hipotez(ler)in doğruluğunu kontrol etmeden teoremi kullanmışlardır. Bu öğretmen adaylarının, teoremi hipotezi ile birlikte bir bütün (*nesne*) olarak değil de sadece verilen problemi çözmek için kullanılan bir yöntem (*süreç*) olarak gördüklerini ve soyutlama seviyesini *süreç-nesne ikililiğinin yansımaları bakımından* indirgediklerini söyleyebiliriz.

Öğretmen adaylarından 4'ü (% 2.9) ise sorunun çözümünde Çin kalan teoremini kullanmalarına rağmen buldukları 2832 sayısını sorunun cevabı olarak kabul etmişlerdir. Bu öğretmen adayları, sorudaki “çobanın en az kaç koyunu vardır?” ifadesine dikkat etmemiş veya teoremi bütünüyle matematiksel bir *nesne* olarak kavrayamamış ve teoremin ispatında kullanılan yöntemi sadece verilen problemi çözmek için kullanılan bir *süreç* olarak görmüşlerdir. Teoremi bir *süreç* olarak algılayan öğretmen adayları, teoreme göre, soruya uygun kongrüans sisteminin, aynı zamanda $m_1.m_2.m_3 = 315$ modülüne göre tek bir çözümü olduğunu ve bu çözümü, $x \equiv 312 \pmod{315}$ kongrüansını veya $x = 312 + 315k$, $k \in \mathbb{Z}$, eşitliğini sağlayan x tamsayıları olacağını ve $k = 0$ için sorunun cevabının 312 olması gerektiğini düşünmemişlerdir. Bu öğretmen adaylarının, soyutlama seviyesini *süreç-nesne ikililiğinin yansımaları bakımından* indirgediklerini söyleyebiliriz.

SONUÇ ve ÖNERİLER

Matematik öğretmen adaylarının Çin kalan teoremi ile ilgili soyutlamayı indirgeme eğilimlerini incelediğimiz bu çalışmada, öğretmen adaylarının sorulan problemle ilgili matematiksel kavramları nasıl anladıkları veya anlaşılabilir hale getirdikleri yani soyutlamayı hangi seviyede indirgedikleri örneklerle gösterilmiştir. Bu çalışmayla, Hazzan'ın (1999, 2001), belirttiği gibi teorik çerçeve olarak *soyutlamanın indirgenmesi* teorisinin, öğrencilerin matematiksel yapıları ve kavramları algılayışlarını açıklama ve yorumlamada kuvvetli bir araç olduğu bir kere daha gösterilmiştir. Problemin çözümünde, öğretmen adaylarının çoğunlukla ortaokul veya lisede pratik çözüm adı altında öğretilen yöntemi veya sorulan soruyla otomatik olarak tetiklenen yöntemi (doğal yöntem) kullanmayı tercih ettikleri görülmüştür. Bu eğilimi gösteren öğretmen adaylarının kendilerinden beklenen soyutlamayı yapmaktan çok ezberledikleri veya kendilerine daha kolay gelen yöntemlere yöneldiklerini söyleyebiliriz. Bu durum, teoremin matematiksel bir nesne olarak kavranmadığının ve içselleştirilemediğinin bir göstergesidir. Bir kısım öğretmen adayının da hipotezini doğrulamadan veya tam olarak uygulamadan teoremi kullanmaları ise matematiksel bir yapı olan teoremin bir bütün olarak değil de sadece belirli bir soru tipinin çözümünde kullanılan bir formül veya yöntem olarak algılandığını göstermektedir. Sayılar teorisi ve soyut cebir gibi teorik derslerin içerdiği kavramların soyutluk seviyeleri, bu derslerin işleniş şekli ve öğrencilerin bu kavramları içselleştirmelerini sağlayacak etkinliklerin düzenlenmesi için yeterli zamanın olmayışı öğrencilerin karşılaştıkları yeni matematiksel yapıları önceki bilgileriyle birlikte özümsemelerini engellemektedir. Bunun için öğretmen adaylarına verilen derslerin içeriğinin ve kapsamının daha çok uygulama ve günlük yaşamla ilişkilendirilmesi yönünde planlanması faydalı olacaktır.

KAYNAKLAR

- Akar Vural, R. ve Cenkseven, F. (2005). Eğitim araştırmalarında örnek olay (vaka) çalışmaları: Tanımı, türleri, aşamaları ve raporlaştırılması. *Süleyman Demirel Üniversitesi Burdur Eğitim Fakültesi Dergisi*, 6(10), 126-139.
- Hazzan, O. (1999). Reducing abstraction level when learning abstract algebra concepts. *Educational Studies in Mathematics*, 40, 71-90.
- Hazzan, O. (2001). Reducing abstraction: The case of constructing an operation table for a group. *Journal of Mathematical Behaviour*, 20(2), 163-172.
- Hazzan, O. (2003a). How students attempt to reduce abstraction in the learning of mathematics and in the learning of computer science. *Computer Science Education*, 13(2), 95-122.
- Hazzan, O. (2003b). Reducing abstraction when learning computability theory. *Journal of Computers in Mathematics and Science Teaching*, 22(2), 95-117.
- Hazzan, O. and Zaskis, R. (2005). Reducing abstraction: The case of school mathematics. *Educational Studies in Mathematics*, 58, 101-119.
- Ing, L. H. (2003). The history of the Chinese remainder theorem. *Mathematical Medley*, 30(1), 54-62.
- Shulman, L. (1987). Knowledge and teaching: Foundations of the new reform. *Harvard Educational Review*, 57(1), 1-22.
- Şenay, H. (2007). *Sayılar Teorisi Dersleri*. Konya: Dizgi Ofset Matbaacılık.
- Zaskis, R. and Campbell, S. R. (2011). Number theory in Mathematics Education: Perspectives and Prospects. In R. Zaskis & S. R. Campbell (Eds.), *Number theory in Mathematics Education: Perspectives and Prospects*. (Chp. 1). New York: Routledge.

SEÇMELİ MATEMATİK UYGULAMALARI DERSİNİ ALAN VE ALMAYAN 5. SINIF ÖĞRENCİLERİNİN MATEMATİĞE YÖNELİK TUTUMLARININ KARŞILAŞTIRILMASI

A COMPARISON OF PRIMARY STUDENTS' ATTITUDES TOWARDS MATHEMATICS: EFFECTS OF AN ELECTIVE COURSE

Özal ÇETİN
Varsak Sakarya Ortaokulu
ozalcetin@gmail.com

Doç.Dr. Mustafa DOĞAN
Necmettin Erbakan Üniversitesi
mdogan69@hotmail.com

ÖZET: Bu çalışmanın amacı seçmeli matematik uygulamaları dersini alan ve almayan 5. sınıf öğrencilerinin matematiğe yönelik tutumlarını incelemektir. Bu amaçla 165 öğrenciye matematiğe yönelik tutum ölçeği uygulanmıştır. Veriler t testi kullanılarak analiz edilmiştir. Sonuçlara göre seçmeli matematik uygulamaları dersini alan öğrencilerin tutumları bu dersi almayan öğrencilere göre daha yüksek bulunmuştur. Ayrıca matematiğe yönelik tutumlarda cinsiyete bağlı bir farklılık görülmemiştir.

Anahtar Sözcükler: matematik eğitimi, tutum, matematik uygulamaları, seçmeli ders

ABSTRACT: Aim of this study is to compare of 5th class primary students' attitudes towards mathematics. Two groups of students' attitudes have been compared. The experimental group has taken an elective "application of mathematics" course. The other group has not selected the elective course. Attitude scales towards mathematics have been used to conduct the study. A total of 165 students involved in the study experiment group. Data were analyzed by independent samples t-test to compare the groups attitudes. The results shows that, the attitude levels of the experiment group who have taken elective applications of mathematics course are quite positive when compared with the normal group. In addition attitude levels do not differ by gender.

Key words: mathematics education, attitude, applications of mathematics, elective mathematics course.

GİRİŞ

Öğrenme sürecinde; bireyin öğrenmesini etkileyen birçok etken bulunmaktadır. Bu sürece etki eden önemli etkenlerden biri de tutumlardır (Çaydaş ve Balcıoğulları, 2004). Literatürde tutum ile ilgili birçok tanım bulunmaktadır. Umay (1997) bir dersle ilgili duyuşsal özellikler ve o dersle ilgili öğrenmelere karşı ilgi/ilgisizlik durumunu tutum olarak adlandırılmaktadır. Smith (1968) ise bir bireye atfedilen ve onun bir psikolojik obje ile ilgili düşünce, duygu ve davranışlarını düzenli bir biçimde oluşturan bir eğilim olarak tanımlamaktadır. Smith'e (1968) göre tutumların temelinde iki önemli özellik yatar: 1- uzun sürelidirler. 2- bilişsel, duygusal ve davranışsal biçimleri içerirler.

Bir objeye yönelik tutum ile o objeye yönelik davranışlar arasında büyük bir ilişki bulunmaktadır. Birey olumsuz tutum geliştirdiği objeye karşı ilgisiz kalır, onu sevmez, takdir etmez ve onunla uğraşmaz, hatta kendisine göre bir iş olmadığını bile düşünür (Baykul, 2006).

Matematiğe yönelik tutum ile matematik başarısı arasında büyük bir ilişki olduğu düşünülmektedir. Nitekim Arun (1998) matematiğe yönelik tutum ile matematik başarısı arasında yüksek bir korelasyon bulunduğunu sonucuna ulaşmıştır. Yapılan birçok çalışmada ise matematik dersindeki başarısızlıkların temelinde matematiğe yönelik olumsuz tutumların olduğu görülmektedir (Cain, 1986; Kulm, 1998).

Gelişmiş ülkeler doğa ve sosyal yapılarıdaki değişimleri önceden görüp vatandaşlarının yararına çevirebilmek için bilim ve teknoloji alanında birçok araştırma/geliştirme çalışmaları yapmaktadırlar. Bu kapsamda Milli Eğitim Bakanlığı (MEB) çeşitli araştırma geliştirme çalışmaları yapmış ve yapmaktadır. Bu çalışmalardan bir

tanesi de 2012-2013 Eğitim Öğretim yılı ile birlikte 5. sınıftan itibaren kademeli olarak bütün ortaokulda matematik uygulamaları seçmeli dersine başlamışlardır.

Milli Eğitim Bakanlığı Matematik uygulamaları dersinin içeriğini şu şekilde açıklamaktadır (MEB, 2013):

“Günlük hayattan matematiğin uygulanacağı gerçek ve kurmaca problemler, diğer bilim alanlarından matematiksel problemler veya soyut matematiksel oyunlar ve problemlerden oluşacaktır. Program öğrencilerin sınıftaki yaşantılarında ağırlıklı olarak bireysel çalışma yerine grup çalışması ve sınıf tartışmasını ve sunumlarını öngörmektedir. Öğrenciler bu süreçte mantıklı olan ve akla yatkın yaklaşım ve çözümleri ortaya çıkaracaktır. Öğretmen bu derste doğru çözüme yönlendirmekten çok, öğrencilerin çözüm yollarını kendilerinin bulmalarına yardımcı olacaktır. Bu yaklaşımla derste hem öğrencilerin matematiksel bilgi ve becerileri derinleşecek, hem de sosyal becerileri ve iletişim becerileri desteklenecektir.”

Bu içerik incelendiğinde matematik uygulamaları dersinde probleme dayalı öğrenme modelinden faydalandığı görülmektedir. Bu kapsamda probleme dayalı öğrenmenin temel prensipleri aşağıdaki gibi özetlenebilir;

- Öğretime bir problem ile başlanır.
- Problem ile öğrencinin dünyası arasında bağlantı kurulur.
- Problem disiplinler üzerinde değil yalnızca konu üzerinde organize edilir.
- Öğrencilere probleme şekil vermeleri ve çözümü baştan sona yönetmeleri için tam yetki verilir.
- Etkili, tam ve bağlamında öğrenme için küçük gruplar oluşturulur.
- Öğrencilere performansları ve çözümleri hakkında sürekli olarak açıklamalarda bulunulur (Kılınç, 2007).

Matematik uygulamaları dersinin öğretim programında bu dersin genel amacı öğrencilere düzeylerine uygun matematiksel uygulamalar yapma fırsatı vererek matematik bilgi ve becerilerini geliştirirken matematiği sevdirmek ve matematiğe karşı olumlu tutum geliştirmektir. Bu genel amacın üç bileşeni bulunmaktadır:

1. Öğrencilerin aldığı zorunlu matematik dersinin genel amaçlarını desteklemek ve matematiksel deneyimlerini problem çözerek zenginleştirmek ve bu yolla matematiksel bilgilerini derinleştirmektir.
2. Öğrencilerin problem çözme ve kurma, akıl yürütme, iletişim, matematiksel kavramlar arasında, matematik ve diğer disiplinler arasında ve matematik ve günlük hayat arasında ilişkilendirme ve matematiksel düşüncelerini çoklu gösterimlerle ifade etme becerilerini geliştirmektir.
3. Öğrencilere matematiği sevdirmek, matematik hakkında doğru değerleri ve problem çözümünde gereken sabrı ve çabayı gösterecek tutumları kazandırmaktır (MEB, 2013).

Matematik uygulamaları dersinin amaçları incelendiğinde tutumların oldukça önemli olduğu görülmektedir. Bu nedenle matematik uygulamaları alan ve bu dersi almayan ortaokul 5. sınıf öğrencilerinin matematiğe yönelik tutumlarının ortaya çıkarılması önemli görülmektedir.

Problem ve alt Problemler

Bu çalışmanın amacı matematik uygulamaları dersini alan ve bu dersi almayan ortaokul 5. Sınıf öğrencilerinin matematiğe yönelik tutumları arasındaki farkı ortaya çıkarmaktır. Bu bağlamda araştırmanın problemi; “Ortaokulda matematik uygulamaları dersini alan ve bu dersi almayan öğrencilerin matematiğe yönelik tutumları arasında bir fark var mıdır?” Alt Problemler:

1. Seçmeli matematik uygulamaları dersi alan ve almayan öğrencilerin matematiğe yönelik tutumları arasında anlamlı bir fark var mıdır?
2. Seçmeli matematik dersi alan öğrencilerin matematiğe yönelik tutumları arasında cinsiyete yönelik ilişki var mıdır?
3. Seçmeli matematik dersi almayan öğrencilerin matematiğe yönelik tutumları arasında cinsiyete yönelik bir ilişki var mıdır?

YÖNTEM

Bu çalışma ortaokullardaki matematik uygulamaları dersini alan ve almayan öğrencilerin tutumları arasındaki fark veya benzerlikleri ortaya çıkarmayı amaçladığından tarama modelinde bir çalışmadır. Tarama modellerinde durumu veya olguları herhangi bir şekilde değiştirme, etkileme çabası yoktur (Karasar, 1999: 77). Var olan durumu ortaya çıkarma amacı taşımaktadır.

Veri Toplama Araçları

Çalışmada öğrencilerin matematiğe yönelik tutumlarını belirlemek amacı ile Eğitimi Araştırma ve Geliştirme Dairesi (EARGED) tarafından geliştirilen matematiğe yönelik tutum ölçeği kullanılmıştır.

Çalışmada kullanılan matematiğe yönelik tutum ölçeğinin güvenilirliği hesaplanmış ve Cronbach Alfa katsayısı ,905 olarak bulunmuştur.

Çalışma Gurubu

Araştırmanın çalışma gurubunu 2013/2014 eğitim öğretim yılında Antalya'daki bir Ortaokul'da öğrenim gören 5. sınıf öğrencileri oluşturmaktadır. Çalışmaya toplam 165 öğrenci katılmış ve öğrencilerle ilgili bilgiler Tablo 1'de gösterilmiştir.

Tablo 1. Çalışma Gurubu İle İlgili Bilgiler

MATEMATİK UYGULAMALARI			
ALİYOR		ALMIYOR	
Kız	Erkek	Kız	Erkek
46	38	26	55
TOPLAM		165	

BULGULAR

Bu bölümde, araştırmanın amacına uygun elde edilen verilerin analizleri sonucunda, araştırmanın alt problemleri ile ilgili bulgulara yer verilmiştir.

1. Seçmeli matematik uygulamaları dersi alan ve almayan öğrencilerin matematiğe yönelik tutumları arasında anlamlı bir fark var mıdır?

Matematik uygulamaları dersi alan ve almayan öğrencilerin matematik tutum ölçeğinden aldıkları puanlar arasında anlamlı bir fark olup olmadığına bağımsız örneklem için t testi yapılarak bakılmış ve sonuçlar tablo 2 ve tablo 3 de gösterilmiştir.

Tablo 2. Matematiğe Yönelik Tutum Puanlarının Matematik Uygulamaları Dersi Değişkenine Göre Dağılımı

Grup	N	Ortalama	Standart Sapma	Standart Hata
Matematik uygulamaları alıyor	84	72,7024	13,72341	1,49735
Matematik uygulamaları almıyor	81	65,6667	16,01640	1,77960

Tablo 3. Öğrencilerin Matematiğe Yönelik Tutum Puanlarının Matematik Uygulamaları Dersi Değişkenine Göre Bağımsız Örneklem t Testi Sonuçları

Ortalamaların Eşitliği için t testi					
		t	Sd	P	Ortalama fark
Matematik Uygulamaları	Varyans eşitliği	3,034	163	,003	7,03571
	Varyans eşitsizliği	3,025	157,353	,003*	7,03571

P<0,05*

Tablo2 incelendiğinde matematik uygulamaları dersini alan öğrencilerin matematik uygulamaları dersini almayan öğrencilere göre tutum puanları daha yüksek bulunmuştur. Bu farkın anlamlılığını incelemek amacı ile bağımsız örneklem t testi yapılmış ve tablo 3 de gösterilmiştir. Tablo 3'e göre t=3,03 ve p<0,05 çıktığından matematik uygulamaları dersi alan ve almayan öğrenciler arasında matematik uygulamaları dersi alan öğrenciler lehine anlamlı bir farkın olduğu görülmektedir.

2. Seçmeli matematik dersi alan öğrencilerin matematiğe yönelik tutumları arasında cinsiyete yönelik ilişki var mıdır?

Matematik uygulamaları dersi alan öğrencilerin matematik tutum ölçeğinden aldıkları puanlar arasında cinsiyet değişkenine göre anlamlı bir fark olup olmadığına bağımsız örneklem için t testi yapılarak bakılmış ve sonuçlar ve sonuçlar tablo 3 ve tablo 4 de gösterilmiştir.

Tablo 4. Matematik Uygulamaları Dersini Alan Öğrencilerin Cinsiyet Değişkenine Göre Dağılımı

Gurup	N	Ortalama	Standart Sapma	Standart Hata
Kız	46	72,0652	14,43053	2,12767
Erkek	38	73,4737	12,96510	2,10322

Tablo 5. Matematik Uygulamaları Alan Öğrencilerin Cinsiyete Göre Bağımsız Örneklem t Testi Sonuçları

		Ortalamaların Eşitliği için t testi			
		t	Sd	P	Ortalama fark
Cinsiyet	Varyans eşitliği	-,466	82	,642	-1,40847
	Varyans eşitsizliği	-,471	81,392	,639	-1,40847

Tablo 4 incelendiğinde matematik uygulamaları dersi alan erkek öğrencilerin tutum puanları toplamı kız öğrencilerin tutum puanları toplamına göre daha yüksek bulunmuştur. Bu farkın anlamlılığını incelemek amacı ile bağımsız örneklem t testi yapılmış ve tablo 4 de gösterilmiştir. Tablo 4 göre $t=-,471$ ve $p>0,05$ çıktığından kız ve erkek öğrencilerin matematiğe yönelik tutumları arasında anlamlı bir fark bulunmamıştır. Yapılan birçok çalışmada matematiğe yönelik tutumun cinsiyet değişkenine göre anlamlı bir fark oluşturmadığı bilinmektedir

3. Seçmeli matematik dersi almayan öğrencilerin matematiğe yönelik tutumları arasında cinsiyete yönelik bir ilişki var mıdır?

Matematik uygulamaları dersi almayan öğrencilerin matematik tutum ölçeğinden aldıkları puanlar arasında cinsiyet değişkenine göre anlamlı bir fark olup olmadığına bağımsız örneklem için t testi yapılarak bakılmış ve sonuçlar ve sonuçlar tablo 6 ve tablo 7 de gösterilmiştir.

Tablo 6. Matematik Uygulamaları dersini almayan öğrencilerin cinsiyet değişkenine göre dağılımı

Gurup	N	Ortalama	Standart Sapma	Standart Hata
Kız	31	68,6774	15,22145	2,73385
Erkek	50	63,8000	16,36073	2,31376

Tablo 6. Matematik Uygulamaları Almayan Öğrencileri Cinsiyete Göre Bağımsız Örneklem t Testi Sonuçları

		Ortalamaların Eşitliği için t testi			
		t	Sd	P	Ortalama fark
Cinsiyet	Varyans eşitliği	1,339	79	,185	4,87742
	Varyans eşitsizliği	1,362	67,246	,178	4,87742

Tablo 6 incelendiğinde matematik uygulamaları almayan kız öğrencilerin tutum puanları toplamı erkek öğrencilerin tutum puanları toplamına göre daha yüksek bulunmuştur. Bu farkın anlamlılığını incelemek amacı ile bağımsız örneklem t testi yapılmış ve tablo 7 de gösterilmiştir. Tablo 7'ye göre $t=1,362$ ve $p>0,05$ çıktığından matematik uygulamaları dersi almayan kız ve erkek öğrencilerin matematiğe yönelik tutumları arasında anlamlı bir fark bulunmamıştır.

SONUÇ VE ÖNERİLER

Seçmeli matematik dersi alan ve almayan öğrencilerin matematiğe yönelik tutumları arasında bu dersi alan öğrencilerin lehine anlamlı bir fark tespit edilmiştir. Seçmeli matematik uygulamaları dersinin amaçları incelendiğinde öğrencilere düzeylerine uygun matematiksel uygulamalar yapma fırsatı vererek matematik bilgi ve becerilerini geliştirirken matematiği sevdirmek ve matematiğe yönelik olumlu tutum geliştirmelerini sağlamak olduğu görülmektedir. Seçmeli matematik uygulamaları dersi alan ve almayan öğrencilerin

matematiğe yönelik tutumları arasındaki bu anlamlı fark seçmeli matematik dersinin en az bir amacına ulaştığını göstermektedir.

Matematik uygulamaları dersinin içeriği problem çözme temelli matematik öğretimi olduğundan bu yönde bir alan yazın incelemesi yapılmıştır. Alan yazın incelemesi problem çözmeye yönelik çalışmaların matematiğe yönelik tutumda olumlu bir etkisi olduğunu göstermektedir (Ku ve Sullivan, 2002; Cantürk Günhan, 2006; Sarıtaş, 2002; Yavuz, 2006).

Seçmeli matematik uygulamaları dersini alan öğrencilerin matematiğe yönelik tutumları arasında cinsiyet değişkenine göre anlamlı bir fark bulunmamıştır. Bu bulgu seçmeli matematik uygulamaları dersinin cinsiyet faktöründen bağımsız olduğunu göstermektedir. Yapılan bazı çalışmalar bu çalışmanın sonucunu desteklemektedir (Özdoğan, Bulut ve Kula, 2005; Arslantürk, 2013; Çelik ve Ceylan, 2009). Ancak bazı çalışmalarda ise matematiğe yönelik tutumun cinsiyet değişkenine göre farklılaştığı tespit edilmiştir (Uysal, 2007; Reçber, 2011; Swetman, 1995; Gavin ve Reis, 2003).

Seçmeli matematik uygulamaları almayan öğrencilerin de matematiğe yönelik tutumları arasında cinsiyet değişkenine göre anlamlı bir fark bulunmamıştır. Bu bulgular matematik uygulamaları dersi alanın veya almamanın matematiğe yönelik tutum üzerinde cinsiyete bağlı herhangi bir etkiye sahip olmadığını göstermektedir.

Bu çalışmanın uluslararası alanda düşük başarı gösterilen; okuduğunu anlama (seçmeli okuma becerileri), fen bilimleri (seçmeli bilim uygulamaları) ve sportif faaliyetler (seçmeli spor ve fiziki etkinlikler) alanlarda da yapılması faydalı olacaktır.

Bu çalışma bütün bir yıla genişletilerek seçmeli matematik uygulamaları dersini alan ve almayan öğrencilerin eğitim öğretim yılı başında ve sonunda matematiğe yönelik tutum puanları karşılaştırılarak yıl içerisindeki değişim de incelenmelidir.

Öğrencilerin 4. sınıf sonundaki matematiğe yönelik tutumları ile 5. sınıf sonundaki matematiğe yönelik tutum puanları incelenerek; seçmeli matematik uygulamaları dersini alan ve almayan öğrencilerin 5. sınıf sonunda matematiğe yönelik tutumları arasındaki farklılaşma durumu incelenmelidir.

KAYNAKLAR

- Arslantürk, E. (2013). *Lise Öğrencilerinin Öğrenim Stratejileri İle Matematik Tutumları Arasındaki İlişki*. Yayınlanmamış Yüksek Lisans Tezi, Yeditepe Üniversitesi, Sosyal Bilimler Enstitüsü, İstanbul.
- Arun, Ö. T. (1998). *Matematik Başarısını Etkileyen Faktörler*. Yayınlanmamış Yüksek Lisans Tezi, Hacettepe Üniversitesi Sosyal Bilimler Enstitüsü, Ankara.
- Baykul, Y. (2006). İlköğretimde Matematik Öğretimi (1 ve 5. Sınıflar). Ankara: Pegem A Yayıncılık.
- Cain, C.M. (1986). Parent And Student Attitudes Toward Mathematics As They Relate To Third Grade Mathematics Achievement.
- Cantürk Günhan, B. (2006). İlköğretim İkinci Kademedeki Probleme Dayalı Öğrenmenin Uygulanabilirliği Üzerine Bir Araştırma. Yayınlanmamış Doktora Tezi, Dokuz Eylül Üniversitesi Eğitim Bilimleri Enstitüsü, İzmir
- Çaydaş, E. ve Balcıoğulları, A. (2004). İlköğretim 6. ve 7. Sınıf Öğrencilerinin Sosyal Bilgiler Dersi'ne Yönelik Tutumlarının Bazı Değişkenler Açısından İncelenmesi. I. Sosyal Bilimler Eğitimi Kongresi Tebliğler. Ankara: MEB Yayınları.
- Çelik, H. C. ve Ceylan, H. (2009). Lise öğrencilerinin matematik ve bilgisayar tutumlarının çeşitli değişkenler açısından karşılaştırılması. *Pamukkale Üniversitesi Eğitim Fakültesi Dergisi*, 26, 92-101.
- Gavin, M. K. & Reis, S. M. (2003). Helping Teachers to Encourage Talented Girls in Mathematics. *Gifted Child Today*, 26, 1, 32-42.
- Kılınç, A. (2007). Probleme Dayalı Öğrenme. *Kastamonu Eğitim Dergisi*. Sayı: 15(2). 561-578.
- Ku, H. Y. ve Sullivan, H. J. (2002). Student performance and attitudes using personalized mathematics instruction. *Educational Technology Research and Development*, 50(1), 21-34.
- Kulm, G. (1998). How To Do Mathematics Curriculum Materials Analysis. *American Association For The Advancement Of Science*, 23-25
- Milli Eğitim Bakanlığı, 2013. Ortaokul ve İmam Hatip Ortaokulu Matematik Uygulamaları Dersi (5, 6, 7 ve 8. Sınıflar) Öğretim Programı. Ankara.

- Özdoğan, G., Bulut, M. ve Kula, F. (2005). Matematik Dersine Yinelik Tutumun ve Başarının, Cinsiyet ve Öğrenim Türü Değişkenlerine Açısından İncelenmesi. *XIV. Ulusal Eğitim Bilimleri Kongresi, Cilt 2, Pamukkale Üniversitesi, Denizli, 995-997.*
- Reçber, Ş. (2011). *An Investigation Of The Relationship Among The Seventh Grade Students' Mathematics Self Efficacy, Mathematics Anxiety, Attitudes Towards Mathematics And Mathematics Achievement Regarding Gender And School Type.* Yayınlanmamış Yüksek Lisans Tezi. Orta Doğu Teknik Üniversitesi, Sosyal Bilimler Enstitüsü, Ankara.
- Sarıtaş, E. (2002). *İşbirlikli ve Geleneksel Sınıflardaki Başarılı ve Başarısız Problem Çözücülerin Kullandıkları Öğrenme Stratejileri, Tutumları ve Edim Düzeyleri.* Yayınlanmamış Doktora Tezi. Dokuz Eylül Üniversitesi, Eğitim Bilimleri Enstitüsü, İzmir.
- Smith, M. B. (1968). <http://www.anadolu.edu.tr/aos/kitap/EHSM/1024/unite12.pdf>. Erişim Tarihi: 04.03.2014,
- Swetman, D. L. (1995). Rural Elementary Students' Attitudes Toward Mathematics. *Rural Educator*, 16, 20-22, 31.
- Umay, A. (1997). İlkokulun İlk Sınıflarında Ölçme, Değerlendirme ve Not Verme. *Nasıl Eğitim Sistemi: Güncel Uygulamalar ve Geleceğe İlişkin Öneriler Eğitim Sempozyumu.* İzmir: D.E.Ü. Sabancı Kültür Sarayı. 477-484.
- Uysal, O. (2007). *İlköğretim II. Kademe Öğrencilerinin Matematik Dersine Yönelik Problem Çözme Becerileri, Kaygıları ve Tutumları Arasındaki İlişkilerin Değerlendirilmesi.* Yayınlanmamış Yüksek Lisans Tezi. Dokuz Eylül Üniversitesi Eğitim Bilimleri Enstitüsü, İzmir.
- Yavuz, G. (2006). *Dokuzuncu Sınıf Matematik Dersinde Problem Çözme Strateji Öğretiminin Duyuşsal Özellikler ve Erişime Etkisi.* Yayınlanmamış Doktora Tezi, Dokuz Eylül Üniversitesi Eğitim Bilimleri Enstitüsü, İzmir.

A PRELIMINARY STUDY FOR DYSCALCULIA IN SABAH, MALAYSIA.

Chin Kin Eng, Vincent Pang, Wong Ken Keong, Tan Choon Keong, Lee Kean Wah,
Lay Yoon Fah

Universiti Malaysia Sabah,
Jalan UMS, 88400 Kota Kinabalu,
Sabah, MALAYSIA

ABSTRACT: In Malaysia, it is reported that the number of registered students with learning disabilities increased from 7,919 in year 2000 to 20,814 in year 2006 (Teoh & Lim, 2007). It is estimated that the prevalence of Dyscalculia in the general population is 5-8% (Adler, 2008). This research intends to develop an instrument for measuring dyscalculia and identify the prevalence of Dyscalculia among primary school students in Sabah, Malaysia. The Dyscalculia instrument developed in this study is a computer-based assessment for children that aims to identify the characteristics of Dyscalculia by measuring response accuracy and response time to test items. The purpose of this paper is to report the results of a preliminary study for Dyscalculia which involved 91 students in three primary schools in Sabah, Malaysia. The results show that 5.5% of the primary school students in Sabah suffer from Dyscalculia.

Key words: Prevalence, Dyscalculia.

INTRODUCTION

In England, 'Dyscalculia' has been defined as 'the condition that affects the ability to acquire mathematical skills. Dyscalculia is a term most commonly used for those having disability in learning mathematics. Dyscalculia means severe or complete inability to count (Hallahan *et al.*, 2005). According to Newman (1998), Dyscalculia means "specific learning disability in mathematics". People with Dyscalculia generally have normal intellectual ability but having troubles in certain thought processes in particular cognitive process (Adler, 2008).

The research of Adler (2008) had supported the long-term study of Shalev and Von Aster (2008) which indicated that many children with Dyscalculia outgrow their diagnosis after a few years. If a child is getting the right treatment and support, the possibility for the development of mathematical ability will increase. There are still some difficulties remain in a milder form such as the problem of recalling numerical facts. It is common that students will continue to have such difficulties in a milder form throughout their lives. The ability to concentrate might be improved greatly and this will help in the understanding of mathematical concepts and symbols.

This study involves the identification of pupils who suffer from Dyscalculia. The instruments used in this study was developed based on the theory of making sense of mathematic as proposed by Chin and Tall (2012) and the concept of numerosity as suggested by Butterworth (2002). Additionally the work by several researchers such as Geary (2006), Murphy (2006), Gersten *et al.* (2008), and Shalev and Von Aster (2007) also contributed to the development of this instrument. Prevalence of Dyscalculia among primary school students in Sabah is obtained by analyzing the data obtained through this instrument.

METHODS AND PROCEDURES

This study focuses on 7-9 year old children who experience difficulties in learning mathematics. The main objective of this project is to design and develop a Malaysian Dyscalculia instrument that can be used to screen and measure the extent of Dyscalculia among primary school students. The identification of learning disabled students involves screening and diagnosis. Screening is used to examine large groups of children to identify those performing above or below the norm. Diagnosis is used to investigate selected children to determine the precise nature of their difficulties (Mohd Sharani Ahmad, 2004).

There are three main constructs in this framework which involves seven tests namely simple reaction time, short term memory, number sense, matching items, dot enumeration, number comparison and arithmetic (see Table 1). In order to ensure that the instrument is fit to be used and measures what it is suppose to measure, the reliability and the validity of the instrument are seriously taken into account (Creswell, 2005). Reliability of the research instrument is based on its consistency to measure what is being measured. While, validity plays a role

of judgement of how well an instrument measures what it purports to measure in a particular context (Cohen & Swedlik, 2005). Table 1 below shows the constructs for Malaysian Dyscalculia instrument developed by the researchers and Table 2 shows the results of analysis of reliability based on Cronbach's index of internal consistency and item fit based on the in-fit square values.

Table 1: Constructs for Malaysian Dyscalculia Instrument

No.	Construct	Description of items	Capacity/Test	Researchers
1	Simple Reaction Time	10 items for left, 10 items for right.	Response Time	Butterworth (2003), Murphy (2006)
2	Short Term Memory	10 items	Short term memory	Gersten et. al (2008)
3	Numerosity			
	(a) Number Sense	10 items	Sense of Numerosity	Buterworth (1999), Geary (2006), Gersten et. al (2008), Shalev & Von Aster (2007)
	(b) Matching Items	10 items	Numerosity as a property of sets	Butterworth (2002), Geary (2006)
	(c) Dot Enumeration	10 items	Enumeration (counting)	Butterworth (2002)
	(d) Number Comparison	10 items	Sense of ordered numerosities	Butterworth (2002)
4	Arithmetic Test	10 items	Arithmetic	Butterworth (2003), Geary (2006)

Table 2: Reliability and Items fit for Malaysian Dyscalculia Instrument

No.	Construct	Cronbach Alpha, α	No of Fit Items
1	Simple Reaction Time	0.800	19/20
2	Short Term Memory	0.720	10/10
3	Matching Item	0.827	10/10
4	Number Sense	0.769	10/10
5	Dot Enumeration	0.845	10/10
6	Numerical Stroop	0.872	10/10
7	Arithmetic Test	0.768	9/10
OVERALL (SCREENER)		0.896	79/80

1. **Simple Reaction Time** is a test to measure the psychomotor response time. Recorded response time is taken into account in order to identify the actual cognitive processing time (Butterworth, 2003). Figure 1 shows the chronology of the items in simple reaction time. This process will be repeated for ten times for left and right hands respectively. The response times on the following six tests are adjusted to take this measure into account.



Figure 1: Simple Reaction Time

2. In general, students with learning disabilities have a very limited working memory (Gersten *et al.*, 2008). Siegal and Ryan (1989) found that children with Dyscalculia did less well than control on a working memory task involving counting and remembering digits. Working memory is **Short Term Memory** (Baddeley, 2002) and the concept of working memory evolved from earlier concepts of **Short Term Memory** (Lervag & Hulme, 2013). Pupils are asked to make a short memory on the picture (see Figure 2) and have to give an answer whether the number of black dots that appear on the left or right of the screen is more.

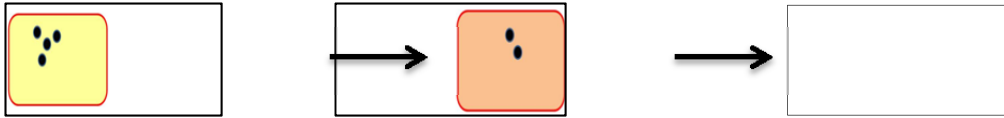

Figure 2: Short Term Memory

3. The idea of numerosity (Butterworth, 1999) involves familiar consequences such as two sets of things might have the same numerosity as the other, or a larger or smaller numerosity. This innate ability is called **Number Sense** (Butterworth, 2002). Figure 3 shows a sample item of number sense which is used to evaluate whether a pupil possesses the concept of quantity and the scientists called this concept as numerosity (Santos-Sousa, 2007). Pupils must provide their answers by identifying which diagram has more black dots.

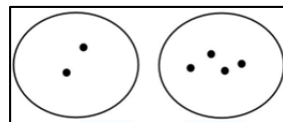

Figure 3: Number Sense

4. Butterworth (2002) proposes that two sets have the same numerosity if and only if the members of each set can be put in a form of one-to-one correspondence with none left over. This involves the principle of matching every item of one set to the items of other set. Hence, the researchers have included **Matching Items** (see Figure 4) in order to test whether a student understands the one-to-one correspondence principle.



Figure 4: Matching Items

5. **Dot Enumeration** is a test (see Figure 5) that requires better skills in counting numerals and using symbols (Butterworth, 2002). Learning the basic counting sequence, “one, two, three and four ...” is not difficult and almost all the children including Dyscalculic students can learn this (Geary 2006). However, it is not only about the sequence but also involved the ability to assign to each counted object and represents the quantity of items in the counted set.



Figure 5: Dot Enumeration

6. According to Geary (2006), Dyscalculia students usually do not know basic number names such as “7” = “Seven”. They have difficulty in discriminating large numbers and small numbers. This difficulty can be identified by using items which are about number comparison such as “Which is bigger, 6 or 8?”. Hence, the **Number Comparison** (see Figure 6) construct is crucial to test the brain area which is specialised for quantity comprehension. According to Butterworth (2002), this is also known as the sense of ordered numerosities.



Figure 6: Number Comparison

7. Many children with Dyscalculia have difficulty in remembering basic arithmetic facts. They have great difficulties in memorising simple addition, subtraction and multiplication facts. The **Arithmetic** test (see Figure

7) is a test which consists of addition and subtraction of two numbers and the children need to choose whether each of the given mathematical statements is true or false.

$3 + 2 = 4$

Figure 7: Arithmetic Test

Classification of Dyscalculia

The model for Dyscalculia Classification (see Figure 8) employed in this research was developed by our research team based on the model of numerical cognition (Von Aster & Shalev, 2007), concept of Numerosity (Butterworth, 1995 & 2002) and the Theory of Cognitive Development in Mathematical Thinking (Tall, 1995 & 2007).

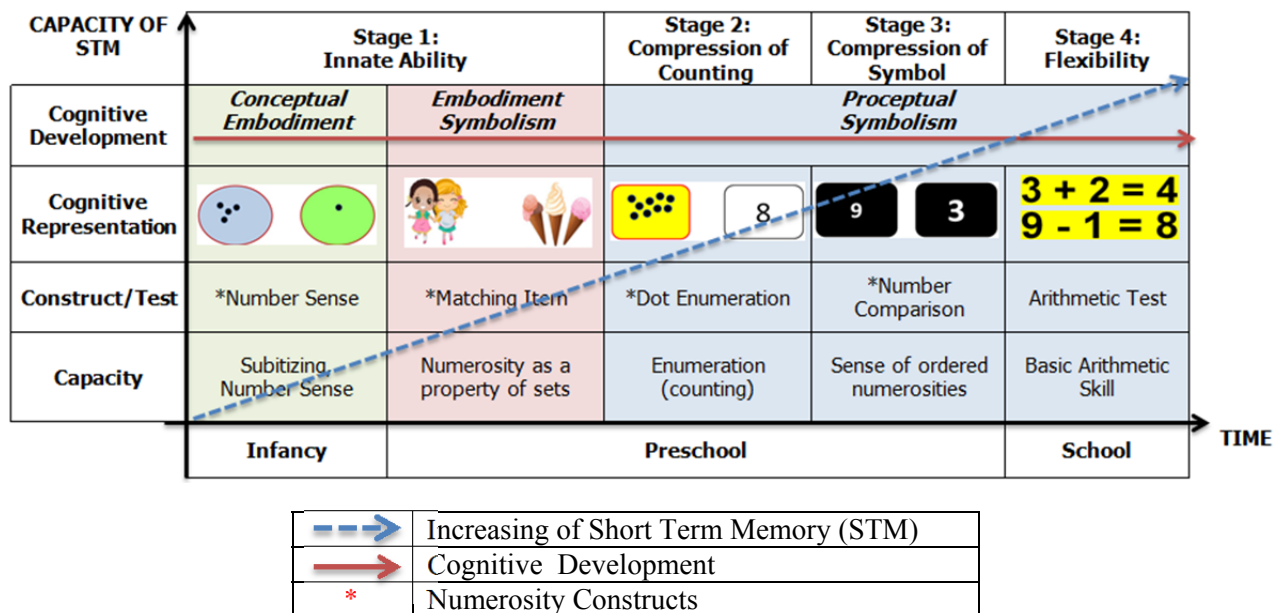

Figure 8: The Model of Dyscalculia Classification

According to this model, a normal pupil (6 and above) should have the ability to perform appropriately from stage 1 to 4 and this involves the ability to compress knowledge into thinkable concepts (Tall, 2006). Based on Feikes and Schwingendorf (2008), complex mathematical thinking will occur if a person is able to compress previous ideas into a compact and precise mathematical object.

In Stage 1, Butterworth's (2003) research outcomes had showed that the infants noticed the constancy of objects and detected differences in their numerical quantities. An infant seems to be able to discriminate visual arrays on the basis of numerosity even in the first week of life. Tall (2008) proposed the notion of 'set before' to denote a mental structure that all humans born with which may take a little time to mature as our brains make connections in early life. *Recognition* of similarities and differences, *repetition* of complex actions that becomes automatic and the use of *language* to name, describe and refine meanings are the three abilities (set before) that form the foundation for the development of mathematical thinking. In other words, these innate abilities help pupils to perform appropriately at this stage. A deficit in these abilities could contribute to Dyscalculia.

Stage 2 and stage 3 have been instrumental to get strong evidence for Dyscalculia (Butterworth, 2003). The ability to compress knowledge into a useable form will give an edge to master the tasks in these stages. In Stage 2, the ability to compress the actions of counting into a number will enable a pupil to answer the items of Dot Enumeration construct correctly. Meanwhile in stage 3, a pupil should be able to compare the numbers displayed on a screen without performing the counting actions because he/she had already compressed the counting actions into a number in stage 2.

In Stage 4, a pupil will achieve the flexibility to see mathematics symbol as process and concept. Tall (2004) used the notion of ‘*procept*’ to indicate this flexibility. It is an idea generated by looking at a symbol such as $3+2$ both as a process (of addition) and a concept (of sum). It was extended by Gray and Tall (2001) to include different symbols and different processes that give rise to the same mental object in the mind of a particular individual. Thus $3+2$, $4+1$, 5 , $7-2$ can all represent the same *procept*, involved in composing and decomposing arithmetic processes that give 5. The task in this stage involves two basic operations (addition and subtraction) of arithmetic as a test of basic arithmetic skill. A deficit of this task could not contribute to Dyscalculia. We can only claim a pupil who is either good in arithmetic or poor in arithmetic based on the results of this task.

Generally, if a pupil can perform appropriately in these four stages, he/she is unlikely to have dyscalculia. Meanwhile, it is possible that the pupil will guess because of an inability to answer the question, but other causes cannot be excluded. To identify such cases, further analysis of data is required for identifying pupils who were guessing the answers to most of the questions in the test.

Table 3: Summary of Dyscalculia Classification

No.	Type	Classification
1	Poor in 4 Numerosity constructs	Evidence of Dyscalculia
2	Poor in Number Sense OR/AND Matching Item Poor in ANY 3 Numerosity constructs	High Risk of Dyscalculia
3	Poor in ANY 2 Numerosity constructs	Moderate Risk of Dyscalculia
4	Poor in ANY 1 Numerosity construct	Low Risk of Dyscalculia
5	Poor in Arithmetic Normal	Poor Arithmetic without dyscalculia Normal Performance
6	Guessing	Guessing

The description of Dyscalculia Classification below is based on Table 3.

Type 1: Poor in 4 Numerosity constructs

The pupil has low performance in all the four capacity tests of numerosity constructs. This pattern of results is evidence of Dyscalculia.

Type 2: Poor in Number Sense OR/AND Poor in Matching Item OR Poor in ANY 3 Numerosity constructs

Sub-type 2.1: Poor in Number Sense OR/AND Matching Item

The pupil has low performance in the Number Sense or/and Matching Item constructs. This pattern of results suggests that the pupil has high risk to have Dyscalculia.

Sub-type 2.2: Poor in ANY 3 Numerosity Construts

The pupil has low performance in three out of the four numerosity constructs. This pattern of results suggests that the pupil has high risk to have Dyscalculia.

Type 3: Poor in ANY 2 Numerosity constructs

The pupil has low performance in two out of the four numerosity constructs. This pattern of results suggests that the pupil has moderate risk to have Dyscalculia.

Type 4: Poor in ANY 1 Numerosity construct

The pupil has low performance in the one of the four numerosity constructs. This pattern of results suggests that the pupil has low risk to have Dyscalculia.

Type 5: Normal Performance in Numerosity Constructs

Sub-type 5.1: Poor in Arithmetic

The pupil performs appropriately in all the numerosity constructs but poor in Arithmetics Test. This pattern of results suggests that the pupil is not failing in arithmetic because of Dyscalculia.

Sub-type 5.2: Normal

The pupil performs appropriately in all the numerosity constructs and Arithmetics Test therefore he/she is unlikely to have Dyscalculia.

Type 6: Guessing

The pupil appears to have been guessing the answers on some or all of the tests. It is not possible to give a diagnosis since there may be various reasons for this behavior, including not trying. It is possible that he/she is Dyscalculic and cannot answer any of the questions satisfactorily.

It is suggested that the test should be repeated on another occasion. If he/she still guesses rather than tries to answer the questions, then he should be provisionally classified as Dyscalculic until further investigation can be carried out.

RESULTS

The preliminary study involved a sample of 91 primary school students aged between 7-9 years old who were selected randomly from three different schools in the state of Sabah, Malaysia. Each student took 10-12 minutes for the screening process. Table 4 shows the result of the preliminary study.

Table 4: Analysis of Preliminary Study

No.	Result/Category	Total	Prevalence (%)
1	Evidence of Dyscalculia	5	5.5
2	High Risk to have Dyscalculia	23	25.3
3	Moderate Risk to have Dyscalculia	1	1.1
4	Low Risk to have Dyscalculia	9	9.9
5	Poor Arithmetic without dyscalculia	9	9.9
6	Normal Performance	44	48.3
	Total	91	100

In this study, 5 out of 91 students were under the category of "Evidence of Dyscalculia" and this is equivalent to a prevalence of 5.5%. Generally, if a pupil can perform appropriately, he/she is unlikely to have Dyscalculia. Meanwhile, a pupil who is incapable of answering a particular question can simply select a random answer and still have chance of receiving score for it. In order to identify such cases, a further analysis of the data is required for identifying pupils who were guessing the answers for most of the items in the test. The result of this study had supported the research of Butterworth *et al.* (2011) which stated that the development Dyscalculia is a mathematics disorder with an estimated prevalence of about 5-7%.

Geary (2004) found that between 5% and 8% of children in school have some forms of disabilities in mathematics. As we can see in Table 5, these figures were confirmed by a number of researchers in different countries. The research study performed by Voutsina and Ismail (2007) in South England showed that the prevalence of Dyscalculia was 5%. Based on Fuchs (2006), the prevalence of Dyscalculia ranges from 4-7%. Meanwhile Belgium researchers found that the prevalence of Dyscalculia ranges from 3-8% (Desoete *et al.*, 2004). Flanagan & Alfonso (2011) conducted a survey of recent work of authors and found that the prevalence was 7%. Reigosa-Crespo *et al.* (2011) discovered that the basic numerical deficits had affected 4.54% of school-age population.

Shalev and Von Aster (2008) reported the prevalence rate of Dyscalculia as 6% and they claimed that the estimation of prevalence was only depends on the accuracy of the diagnosis which could be based on a valid instruments test and representing the whole population. Although there were differences in the use of criteria and test instruments in different research studies however the prevalence rate obtained was around 6% thus this estimate is reliable.

Table 5: Prevalence Rate of Dyscalculia by Several Researchers

Author	Prevalence	Methodology	Location
Voutsina. C. & Qaimah Ismail. (2007)	5 %	Dyscalculia Screener (Butterworth, 2003)	South England

Geary D. C. (2004)	5 – 8%	survey of recent work of authors	Columbia
Desoete, A., Roeyers, H. & De Clercq, A. (2004).	3 – 8%	TEDI-MATH a Belgian dyscalculia battery	Belgium
Teresa Guillemot	3 – 6%	survey of recent work of authors	Sweden
Butterworth et.al (2011)	5 – 7%	Dyscalculia Screener (Butterworth, 2003)	UK
Fuchs, L. S. (2006)	4 – 7%	intervention approach: conceptual instruction and drill and practice	United State
Reigosa-Crespo et. al (2011)	4.54%	Dyscalculia Screener (Butterworth, 2003)	Havana, Cuba.
Shalev, R. S., & von Aster, M. G. (2008)	6%	survey of recent work of authors	few different countries
Flanagan & Alfonso (2011)	7%	survey of recent work of authors	-

CONCLUSION

The prevalence of learning disabilities among school children varies from country to country. This is largely dependent on the definition used to classify learning disabled children in each country. This involved about 5.5% of the students in school (aged 6 to 17) for special education due to learning disabilities (Teoh, Cheong & Woo, 2007). In a study conducted by Komoula *et al.* (2004) which involved 240 Greek students aged between of 7 - 11 years old from rural and urban areas, they had found that the prevalence of developmental Dyscalculia among rural students was higher than in urban schools. Therefore, specific learning disability might be more common among rural students.

In 1991, the National Statistical Office of Thailand reported a prevalence rate of 1.9% for visual impairment, 5.4% for speech impairment, 13.2% for hearing impairment and 10% for intellectual disability. In 2002, the Malaysia Department of Special Education reported 14,535 children with learning disabilities in 700 schools across the country. These statistics included children who had learning disabilities, hearing impairment and visually impaired in special schools or integrated schools (Teoh, Cheong & Woo, 2008). Although the prevalence of mathematics disability is high, the research in this domain is limited (Desoete, Roeyers & De Clercq, 2004). Nowadays, more studies on this issue have evolved (Butterworth, Varma & Laurillard, 2011).

Recently, more attention is focused on students who demonstrated challenges in learning mathematics skills and concepts taught in schools at all levels. Starting as early as pre-school, parents, educators, and researchers are aware that some students seem easily to be confused with the simple mathematical learning skills. For example, some young children have difficulties in learning numbers, recognizing, and counting items in a group. Some of these children continue to show these mathematical learning difficulties as they attend the mathematics lessons. All these difficulties might be related to Dyscalculia therefore by realizing that 5% to 8% of school-age children are identified as having a mathematics disability (Braynt, 2005), we will be in a better position in helping the children to cope with this learning disability.

REFERENCES

- Adler, B. (2008). *What is dyscalculia?* Cognitive Centre in Sweden. Retrieved from <http://www.dyscalculiainfo.org/>.
- Bandeley, A. D. (2002). Is Working Memory Still Working? *European Psycholigisy*. 7(2): 85-97.
- Bryant, D. P. (2005). *Math disability in children: an overview*. Charles and Helen Schwab Foundation.
- Butterworth, B. (2002). *Screening for dyscalculia: A new approach. mathematical difficulties: Psychology, neuroscience and interventions*. Oxford: SEN Presentation Summary.
- Butterworth, B. Varma, S. & Laurillard, D. (2011). Dyscalculia: from brain to education. *Science*, 332, 1049-1053.
- Butterworth, B. & Laurillard, D. (2011). Low Numeracy and Dyscalculia: Identification and Intervention, *42(6)*, 527- 539
- Butterworth, B. (1999). *The mathematical brain*. London: Macmillan.
- Butterworth, B. (2003). *Dyscalculia screener: highlighting children with specific learning difficulties in maths*: London: nferNelson Publishing Company Limited.
- Chin, Kin-Eng. & Tall, D. (2012). Making Sense of Mathematics through perception, operation and reason: the case of trigonometric functions. *The 36th Conference of the International Group for the Psychology of Mathematics Education*, Taipei.

- Cohen, R. J. & Swerdlik, M.E. (2005). *Psychological testing and assessment (6th edition)*. New York: McGraw Hill.
- Creswell, J. W. 2005. *Educational research: planning, conducting, and evaluating quantitative and qualitative research*. New Jersey: Pearson Education.
- Desoete, A., Roeyers, H. & De Clercq, A. (2004). Children with mathematics learning disabilities in Belgium. *Journal of Learning Disabilities*, 37, 50-61.
- Feikes, D. & Schwingendorf, K. (2008). The Importance of Compression in Children's Learning of Mathematics and Teacher's Learning to Teach Mathematics. *Mediterranean Journal for Research in Mathematics Education*, 7(2).
- Flanagan, D. P. & Alfonso, V. C. (2011). *Essentials of specific learning disability identification*. New Jersey: John Wiley & Sons, Inc.
- Fuchs, L. S. (2006). *Strategies to enhance young children's mathematical development*. Encyclopedia on Early Childhood Development. Centre of Excellence for Early Childhood Development.
- Geary, D. C. (2004). Mathematics and learning disabilities. *Journal of Learning Disabilities*, 37, 4-15.
- Geary, D. C. (2006). *Dyscalculia at an early age: Characteristics and potential influence on socio-emotional development*. Encyclopedia on Early Childhood Development. Centre of Excellence for Early Childhood Development.
- Gray, E. M. & Tall, D. O. (2001). Relationships between embodied objects and procepts: an explanatory theory of success and failure in mathematics. *Proceedings of PME25, Utrecht*, 65–72.
- Gersten, R., Chard, D., Jayanthi, M., Baker, S., Morphy, P., & Flojo, J. (2008). *Mathematics instruction for students with learning disabilities or difficulty learning mathematics: A synthesis of the intervention research*. United State of America: Center On Instruction.
- Hallahan, D. P., Lloyd, J. W., Kaufman, J. M., Weiss, M. P. & Martinez, E. A. (2005). *Learning disabilities: foundations, characteristics, and effective teaching*. United States of America: Pearson Education.
- Koumoula A, Tsironi V, Stamouli V, Bardani I, Siapati S, Graham A. et al. (2004). An epidemiological study of number processing and mental calculation in greek school children. *Journal of Learning Disabilities*, 37, 377-388.
- Lervag, M. M. & Hulme, C. 2013. Is Working Memory Training Effective? A Meta-Analytic Review. *Development Psychology*. 49(2), 270-291.
- Mohd. Sharani Ahmad. (2004). *Special children*. Selangor Darul Ehsan: Universiti Putra Malaysia Press.
- Murphy, C. (2006). Embodiment and reasoning in children's invented calculation strategies. *Proceedings 30th Conference of the International Group for the Psychology of Mathematics Education*, 4, 217-224
- Newman, R. M. (1998). *The dyscalculia syndrome*. Special Education Thesis, Dearborn, United State of America: Michigan.
- Reigosa-Crespo, V., Valdas-Sosa, M., Butterworth, B., Estavez, N., Rodr guez, M., Santos, E., Torres, P., Suarez, R. & Lage, A. (2011). Basic numerical capacities and prevalence of developmental dyscalculia: The havana survey. *Developmental Psychology*, 47, 1-13.
- Santos-Sousa, M. (2007). *Natural Mathematics*. In: EPSA07: 1st Conference of the European Philosophy of Science Association, Madrid.
- Shalev, R. S., & von Aster, M. G. (2007). Number development and developmental dyscalculia. *Developmental Medicine & Child Neurology*, 49, 868–873.
- Tall, D. (1995). Cognitive Growth in Elementary and Advanced Mathematical Thinking. *Conference of the International Group for the Psychology of Learning Mathematics, Recife, Brazil*, 1, 161–175.
- Tall, D. (2004). Introducing Three Worlds of Mathematics. *For the Learning of Mathematics*, 23(3). 29–33.
- Tall, D. (2006). Developing a Theory of Mathematical Growth. To appear in *International Reviews on Mathematical Education (ZDM)*.
- Tall, D. (2007). Embodiment, Symbolism and Formalism in Undergraduate Mathematics Education. *10th Conference of the Special Interest Group of the Mathematical Association of America on Research in Undergraduate Mathematics Education*, San Diego, California, USA.
- Tall, D. (2008). *The Historical & Individual Development of Mathematical Thinking: Ideas that are set-before and met-before*. United Kingdom: University of Warwick.
- Teoh Hooi-Ting & Lim Ming-Koon (2007). *Situation of Persons with learning disabilities and their families in malaysia*. Paper presented at the Regional Workshop on the Empowerment of Persons with Intellectual Disabilities and their Families in Asia and the Pacific, Shanghai, China. Retrived from <http://www.worldenable.net/shanghai2007/papermalaysia.htm>
- Voutsina, C. & Qaimah Ismail. (2007). Issues in identifying children with specific arithmetic difficulties through standardised testing: A critical discussion of different cases. *Proceedings of the British Society for Research into Learning Mathematics* 2007.

A THEORETICAL FRAMEWORK FOR DYSCALCULIA

Kin Eng CHI

Vincent PANG

Ken Keong WONG

Choon Keong TAN

Kean Wah LEE

Dr. Lay Yoon FAH

The purpose of this paper is to introduce a new theoretical framework which was formulated in a study of Dyscalculia. This framework is formulated based on the theory of making sense of mathematics through perception, operation and reason as proposed by Chin & Tall (2012). Additionally this framework evolves from the theory of cognitive development in mathematical thinking as suggested by Tall (1995 & 2004). There are three main constructs in this framework which involved seven tests namely simple reaction time, short term memory, number sense, matching Items, dot enumeration, number comparison and arithmetic. In general, this study is concerned with the development of an instrument for diagnosing Dyscalculia and the proposed framework has guided us to the development of the mathematical items for diagnosing Dyscalculia. The core idea of Dyscalculia in this study is based on the concept of numerosity as suggested by Butterworth (2002). The work of Murphy (2006), Geary (2006), Gersten et. Al (2008) and Shalev & Von Aster (2007) have contributed to the understanding of symptoms and causes of Dyscalculia in this study.

Keywords: Perception, Operation, Reason, Dyscalculia

“YEŞİL KUTU” ÇEVRE EĞİTİMİ PROJESİNİN FEN VE TEKNOLOJİ ÖĞRETMEN ADAYLARININ ÇEVRE DOSTU DAVRANIŞLARINA ETKİSİ

THE EFFECT OF “GREEN PACK” ENVIRONMENTAL EDUCATION PROJECT ON THE ENVIRONMENTAL BEHAVIOURS OF THE PROSPECTIVE SCIENCE AND TECHNOLOGY TEACHERS

Yrd. Doç. Elif ÖZTÜRK
Giresun Üniversitesi
elifdenizese@yahoo.com

Doç. Dr. Sinan ERTEN
Hacettepe Üniversitesi
serten@hacettepe.edu.tr

ÖZET: Öğretmen adaylarının hizmet öncesinde edindikleri davranış ve tutumların, biriktirdikleri bilgi zenginliğinin hizmet sırasında öğrencilere verecekleri çevre eğitimini etkileyeceği düşünülmektedir. Bu araştırmanın amacı uluslararası bir çevre eğitimi programı olan “Yeşil Kutu” Projesinin fen ve teknoloji öğretmen adaylarının çevreye yönelik yararlı davranışları üzerindeki etkisini araştırmaktır. Bu çalışma, 2012-2013 Eğitim-Öğretim Yılında bir üniversitede öğrenim gören Fen Bilgisi Öğretmenliği üçüncü sınıf öğrencileri ile yapılmıştır. İlgili bölüme kayıtlı üçüncü sınıf fen ve teknoloji öğretmen adaylarının bir şubesi (N=30) deney grubuna, diğer bir şubesi (N=30) kontrol grubuna atanmıştır. Araştırmada deneysel yöntemin ön test- son test deney ve kontrol gruplu deseni kullanılmıştır. Erten (2000) tarafından geliştirilen “Çevre Bilinci Ölçeği” (ÇBÖ) ile veri toplanmıştır. Elde edilen bulgulara göre, bu eğitimin sonucunda deney grubundaki adayların çevreye yönelik davranışları lehine anlamlı bir artış olduğu görülmüştür. Yani, özetle, araştırma kapsamında verilen çevre eğitimi öğretmen adaylarının çevreye yönelik davranışlarını geliştirmiştir.

Anahtar Kelimeler: fen ve teknoloji öğretmen adayı, çevre eğitimi, çevreye yönelik davranışlar

ABSTRACT: It is thought that environmental awareness; knowledge, behaviors and attitudes that has been gained by prospective teachers, will influence environmental education that they would transfer to the students during their service process. The purpose of the education is to search about the effect of an international environmental education project “Green Pack” on the prospective science and technology teachers’ environmental behaviors. This study is conducted on students who study at science and technology education department of a university on 3rd grade at 2012-2013 academic years. One section of 3rd grade science and technology education is accredited to (N=30) whereas the other section is accredited to (N=30) control class. In this study, a model of experimental research design consisting pretest and posttest of experimental and control groups are being used. Data has been collected by Environmental Awareness Scale (EAS) formed by Erten (2000). The instrument contains different tests that measure indicated dimensions. According to research, an expressive increase in favor of environmental behaviors was obtained. As a result of the study, the environmental education which has been given during the study does not affect prospective teachers. In addition to that, in terms of behavior test scores of environmental awareness scale (EAS), there has been no improvement in control group whereas the prospective science and technology teachers who are in the experimental group have shown significant increase. The most important externalized indicator that should be shown by individuals will be the environment friendly behaviors. According to both the data gained by research, it is obviously presented that the behaviors of prospective teachers have been significantly changed.

Keywords: prospective science and technology teacher, environmental education, environmental behaviours

GİRİŞ

İnsanın tarihsel gelişimi doğadan uzaklaşmasını da beraberinde getirmiştir. Yüzyıllar boyunca doğa, toprak ve diğer tüm canlılarla birebir etkileşim halinde olan insanoğlu zamanla, her geçen yüzyıl ile birlikte, onlardan

uzaklaşmış ve kendini tanıma sürecini yaşarken diğer canlılara olan saygısını yitirmeye başlamıştır. Ortaya çıkan teknolojik gelişmeler, kentleşme, nüfus artışı gibi faktörler insanın toprakla arasını açmış, endüstrileşme ve sanayileşme tarımsal yaşam koşullarını dahi olumsuz etkilemiştir. Elbette ki insanın çok eskiden doğayla dost bir hayat sürmesi yine çıkar ve istekleriyle alakalıdır (Pooley ve O'Connor, 2000). Çünkü eski tarihlerden beri insanın temel ihtiyaçları buradan karşılanmaktadır. Barınma, yeme-içme, avlanma, hayvan yetiştirme gibi durumların tamamı insanın temel ihtiyaçları sebebiyle sürdürdüğü faaliyetlerdir (Reiss ve Chapman, 1998). Bununla birlikte, insanın doğayı ve çevresini koruması açısından diğer canlılara sevgi duyması da tabii ki insanın doğasında var olan ikincil planda kalan bir koruma faktörü olduğu söylenebilir. Günümüz koşullarında ise işler değişmiştir. Sanayi devrimi ile birlikte başlayan süreç her ne kadar insanı bilimde geliştirmeye, “bilgiye” götürse de onu var olan biyolojik koşullarından ve ekolojik ortamından soyutlamıştır (Öztürk, 2013).

19. yy ile birlikte hızlı bir teknolojik değişim sürecine giren insanoğlu, bu sırada çevreye ve doğal yaşama verdiği zararı fark etmiş ve önlemler almaya başlamıştır (Palmer, 1995). Bu; durumun ciddiyetini anlamaya başlanmasından kaynaklanmaktadır. Çevreyi ve doğayı koruma önlemleri ister ben merkezli ve çıkarıcı eğilimlerinden (antroposentrik düşünce) olsun, ister gerçekten içinde yatan doğa ve yaşam sevgisinden (ekosentrik düşünce) olsun, şu anki koşullarda dünyanın her yerinde uygulanması gereken yaptırımları içermelidir. Ekosentrik düşüncelere sahip bireyler doğayı gerçekten değer verilmeye layık bulduğu, bitkileri ve hayvanları; daha doğrusu tüm canlıları değerli gördüğü için çevreye duyarlı davranır. Antroposentrik kişiler ise çevreyi insanların yaşam kalitesinin yükseltilmesinde ve insanın yaşamını devam ettirmesinde vazgeçilmez olduğu için korumak isterler (Erten, 2011). Bu faydacı bir görüştür. Dolayısıyla, bir bireyin çevresiyle, bitkilerle ve hayvanlarla ilgilenmesinin hangi düşünce yapısından kaynaklandığının bilinmesi onun davranışlarına zemin hazırlayan önemli bir anlayıştır.

Çevre problemleri yalnızca ortaya çıktığı yerlerde kalmamakta ve dünyanın çok farklı bölgelerini de etkilemektedir. Elbette etrafında olan çevresel sorunları fark eden insan, bu problemlerin çözümüne odaklanabilir. Ancak, insanda bulunan bu içsel dürtüler, saf çıkarıcı düşünce anlayışlarından kaynaklansa bile daha kapsamlı bir eğitimle, sürekli davranışlara dönüşmelidir. Çevreye karşı olumlu tutumlara sahip, dost ve yaralı davranışlar sergileyen, hatta bunları bir yaşam tarzı haline getiren, kendinden sonraki nesilleri de bu anlayışla büyüten bireyler yetiştirilmelidir. Bu da ancak bilinçli bir çevre eğitimi ile olabilir.

Çevre eğitimi: Yeni bir insan tipini, ahlak anlayışını ve tüketim bilincini topluma kazandırmayı, ihtiyacı kadar tüketen, gelecek nesillere karşı sorumluluk hisseden, çevre sorunlarına karşı duyarlı ve çevre dostu davranış gösterebilen çevre bilincine sahip insan modeli yetiştirmeyi amaçlayan öğrenme alanı

Davranış: Organizmanın doğrudan ya da dolaylı olarak gözlenebilen her türlü hareketi

Çevreye yararlı davranışlar (ÇD): Çevrenin korunması için gösterilen gerçek çevre dostu davranışlar ve öğretmen adaylarının çevrenin korunması için kendi çıkarlarından taviz vermesi ve gerektiğinde çevre sorunlarını azaltma veya bu sorunların ortadan kaldırılması için maddi katkılarda bulunmaları



Yukarıda belirtilen tanımından da anlaşılacağı gibi çevrenin korunması, mevcut sorunların ve tehditlerin azaltılması ve geleceğe yönelik kalıcı önlemlerin alınması ancak bireylerin çevreye bilgi ve olumlu tutumlarının davranışlara dönüşmesiyle gerçekleşebilir. Çevre eğitimine yönelik diğer ülkelerde yapılan araştırmalarda çevre dostu davranışlar ve bunları etkileyen faktörlere daha fazla yer verildiği görülürken ülkemizde bu örneklerin az olduğu söylenebilir. Bu çalışma ile çevre eğitimi alanında, ülkemizde özellikle çevreye yararlı davranışlar hususunda, diğer araştırmacılara öncü niteliğinde bir yol açacağı düşünülmüştür. Yukarıda da belirtildiği gibi öğretmen adaylarına çevre bilincini bütün boyutlarını göz önüne alarak tam ve doğru kazandırılması gerekmektedir. Etkili bir lisans dersiyle bunun gerçekleştirilebileceği düşünülmektedir. Bunun için birçok ülkede yürütülen uluslararası bir çevre eğitimi programı (Yeşil Kutu) incelenmiş ve ülkemizde “çevre bilimi” lisans dersiyle bütünleştirilmesinin, öğretmen adaylarına iyi düzeyde bir çevre bilgisi, olumlu tutumlar ve çevre

dostu davranışlar içeren etkin bir çevre bilinci kazandıracakı öngörölmüştür. Aynı zamanda, bu araştırma ışığında elde edilen sonuçlar ve getirilen önerilerin çevre eğitimi alanındaki araştırmacılara ve eğitimcilere yol göstermesi hedeflenmiştir.

Uluslararası Bir Çevre Eğitimi Projesi: Yeşil Kutu

Yeşil Kutu Projesi MEB ortaklığı, üniversiteler ve alanda uzman akademisyenlerin işbirliği ile birlikte çalışmalar yapıldıktan sonra, çevre eğitiminin tüm bu alt konularını birleştirmeyi hedeflemiş bir projedir. Diğer program ve projeleri göz önüne alarak çevre eğitiminin temel unsurlarını (çevrenin öğeleri, tehditler ve baskılar, insan etkinlikleri ve etkileri, küresel sorunlar ve değerler) konu edinmiş bir eğitim programıdır (Tüysüzöğlü, 2005). Hedef kitleye bilgi vermeyi, çevreye yönelik kalıcı ve olumlu tutum ve değerler oluşturmayı amaçlamaktadır. Bu nedenle kapsamlı ve günümüz koşullarında oldukça ihtiyaç duyulan bir proje olduğu düşünölmektedir.

Projenin ilköğretim okullarında uygulanabilmesi için öncelikle öğretmenlerin bu eğitimi almış olmaları gerekmektedir. Bu nedenle bu araştırmada gelecekte öğretmenlik yapacak öğretmen adaylarına hizmet öncesinde Yeşil Kutu Projesi kapsamında eğitim vermenin, adayların çevreye yönelik tutumlarında, davranışlarında ve çevreye yönelik bilgilerinde etkili olacağı öngörölmektedir.

YÖNTEM

Bu araştırmada deneysel yöntemin ön test- son test deney ve kontrol gruplu deseni kullanılmıştır. Bu desen şöyle gösterilebilir:

GRUP	ÖN TEST	ÖĞRETİM SÜRECİ	SON TEST
Kontrol Grubu (G1)	Çevre Bilinci Ölçeği (ÇBÖ)	Mevcut Program	Çevre Bilinci Ölçeği (ÇBÖ)
Deney Grubu (G2)	Çevre Bilinci Ölçeği (ÇBÖ)	Yeşil Kutu Proje Uygulamalarına göre Program	Çevre Bilinci Ölçeği (ÇBÖ)

Çalışmada deneysel yöntem kullanıldığından evren ve örneklem tayinine gidilmemiştir. Bu çalışma, 2012-2013 Eğitim-Öğretim Yılında bir üniversitenin Fen Bilgisi Öğretmenliği üçüncü sınıf öğrencileri ile yapılmıştır. İlgili bölüme kayıtlı üçüncü sınıf düzeyinde öğrenim gören fen ve teknoloji öğretmen adaylarının bir şubesi (N=30) deney grubuna, diğer bir şubesi (N=30) kontrol grubuna atanmıştır.

Veri toplama aracı olarak Erten (2000) tarafından geliştirilen “Çevre Bilinci Ölçeği” (ÇBÖ) kullanılmıştır. Bu ölçek çevreye yönelik farklı boyutları ölçen üç ayrı test içermektedir. Ölçekte, öğrencilerin çevre hakkındaki bilgilerinin, çevreye yönelik tutumlarını ve çevreyi korumaya yönelik davranışlarını içeren 20 tutum, 20 davranış ve 20 çevre bilgisine ait olmak üzere toplam 60 madde vardır. Erten’e (2005) göre davranış testinde çevrenin korunması için gösterilen gerçek davranışlar yer almaktadır. Dolayısıyla, ölçekteki maddeler bu çalışmada kazanılması hedeflenen davranışları içermektedir. Çalışma sonunda, Yeşil Kutu Projesi uygulamalarına göre işlenen dersin çevreye yönelik olumlu davranış geliştirmede anlamlı bir fark oluşturup oluşturmadığının incelenmesi hedeflenmiştir. Ölçeğin Erten tarafından yapılan önceki çalışmalarda Cronbach güvenilirliği .97’dir. Bu çalışmada ise ölçeğin güvenilirlik değeri .82’dir.

Süreç öncesinde, ÇBÖ ön test olarak uygulanmış ve elde edilen veriler üzerinde betimsel analizler yapılarak çevreye yönelik davranışların ne derece açıklandığı incelenmiştir. Yeşil Kutu Projesi ile ilgili etkinlikler ve uygulamalar, ilgili sınıf düzeyinde dönem boyunca uygulandıktan sonra, aynı ölçekler gruba son test olarak uygulanmış ve arada anlamlı bir farkın olup olmadığına bakılmıştır.

BULGULAR

Bu arařtırmada; verilen eđitimin ođretmen adaylarının evre dostu davranıřlarına etkisi incelenmiřtir. Bunun iin, “Yeřil Kutu” Projesi ve uygulamaları fen ve teknoloji ođretmen adaylarının evreye ynelik davranıřları zerinde etkili midir? (Bireylerde istendik davranıř deđiřikliđi oluřturmuř mudur?) sorusuna yanıt aranmıřtır. Bu amala, fen ve teknoloji ođretmen adaylarının, kontrol ve deney grubu n test ve son test davranıř boyutu puanları arasında t testi uygulanmıřtır. Buna gre, ařađıdaki tabloda deney ve kontrol grubunun B davranıř boyutuna ait betimsel istatistikler ve t testi sonuları sunulmuřtur.

Tablo 1. Deney ve Kontrol Grubunun B Davranıř Boyutuna ait Betimsel İstatistikler ve t Testi Sonuları

	Test eřidi	N	Ortalama	s.s	s.d	t	p
Kontrol Grubu	n Test	30	60.1000	9.10153	29	-3.138	0.074
	Son Test	30	64.4333	9.42094			
Deney Grubu	n Test	30	64.1667	7.15871	29	4.294	*0.000
	Son Test	30	73.2333	8.57295			

Fen ve teknoloji ođretmen adaylarının evreye ynelik davranıřları incelendiđinde, Tablo 1.de grldđi gibi kontrol grubuna uygulanan ilk testin ortalaması 60.10, standart sapması 9.10 olarak belirlenmiřtir. Son testin ortalaması 64.43 iken standart sapma 9.42 dr. Kontrol grubunda uygulanmıř bu iki testin ortalaması arasında artıř olsa bile ($p=0.074<0.05$) evreye ynelik davranıř boyutundaki bu artıř istatistiksel olarak anlamlı farklılık gstermemektedir.

Deney grubuna uygulanan n test puanlarının ortalaması 64.16, standart sapması 7.15 iken ders sonrası uygulanan testin ortalaması 73,23, standart sapması 8.57’dir. Bu durumda, evreye ynelik davranıř boyutu bakımından deney grubunda uygulanan testlerin ortalamaları istatistiksel olarak **anlamlı** bir farklılık ($p=0.000<0.05$) gsterdiđi grlmektedir.

SONU

Kaiser ve diđerleri (1996), “evreye ynelik tutum ve evreye dair davranıř” isimli alıřmada, evreye karřı olumlu tutum oluřturularak, evresel davranıřın habercisi olan evre psikolojisi yapılandırılmıřtır. Ajzen’in planlı davranıř teorisine dayanan bu alıřmada tutum kavramı ve olabilirlik lm yaklaşımı birleřtirilmiřtir. alıřmada faktr analizi řeklinde  lmn ortagonal boyutları dođrulanmıřtır:

1. evre bilgisi
2. evre deđerleri (tutum) ve
3. evreye yararlı davranıřlar

Bu yaklaşım, bu alıřmadaki evre bilinci yaklaşımıyla aynı anlayıřtadır. evre bilincini, bilgi tutum ve davranıřlar rnts olarak grrken, evreye ynelik davranıřın nemi vurgulanmıřtır. Diđer bir lmde, genel evre davranıřları ile kiřilerin gerek davranıřlarının arkasındaki etkiler incelenerek deđerlendirilmiřtir. evre bilgisi ve evresel tutumların, evreye ynelik davranıřların 40 %’ını deđerliřtirdiđi grlmřtir. Dolayısıyla, bireylerin herhangi bir eđitim almadan da evreye ynelik bazı davranıřlarının, etkili bir eđitimle geliřmesi beklenmektedir. Bu alıřma ile evre bilincinin nemli bir ayađı olan davranıř boyutunun nemi vurgulanmıřtır.

Sonu olarak, her iki grubun da davranıř boyutu test puanlarında artıř belirlenmiřtir. Ancak bu artıř deney grubu davranıř boyutu puan ortalamalarında daha yksektir. Yapılan t-testi sonularına gre, bu durumda, “Yeřil Kutu” Projesi uygulamalarıyla iřlenen derslerin ođretmen adaylarında **anlamlı dzeyde** davranıř deđerliřliđi oluřturduđu sylenebilir. Bu sonu arařtırmanın hedefleriyle rtřmektedir. nk etkili ve srekli bir evre bilincinin oluřmasında karřılařılan en nemli problem đrenilenlerin davranıřa dnřmemesidir. Her ne kadar

bireylere verilen çevre eğitimleri sonrasında, bilgi düzeylerinde veya tutumlarında artış gözlenirse de, bu bilgilerin maalesef hayata geçirilmediği görülmektedir. Dolayısıyla verilen eğitimler yalnızca bilişsel ve duyuşsal boyutta kalmakta, psikomotor becerilerin gelişimine destek olmamaktadır. Erten (2005) okulöncesi öğretmen adaylarıyla yaptığı çalışmada çevreye yönelik olumlu tutumlar ile sergilenen davranışlar arasındaki tutarsızlıkları ortaya koymuştur. Buradan hareketle, iyi bir çevre bilinci kazandırmada yalnızca *bilgiyi öğrenmeye* odaklanmadan davranış kazandırmanın önemi anlaşılmalıdır. Bu araştırmanın en önemli hedeflerinden biri çevreye yönelik davranışların verilen çevre eğitimiyle kazandırılması göz önüne alınırsa, bu sonuçla birlikte çevre dostu davranışların geliştiği görülmektedir.

Önceki araştırmalarda belirtilen sonuçlara göre (Erten, 2003; Erten, 2012; Keleş ve diğ. , 2010) çevre eğitiminde öğrenilen bilgilerin gerçek yaşamda davranışlara dönüştürülemediği göz önüne alınırsa, bu sonuçlar dikkate alınarak tüm üniversitelerin çevre bilimi lisans dersinde uygulanacak eğitim programı güncelleştirilmesi gerektiği söylenebilir. Bu çalışmada çevre dostu davranışları artıran faktörler, çevre eğitiminde öne çıkarılmalıdır. Bu faktörlerin; çevre bilimi derslerinin dönem boyunca yaparak yaşayarak öğrenme prensibine göre öğrencilerin aktif katılımını sağlayacak şekilde gerçekleştirilmiş olması, uygulamalardaki bazı etkinliklerin yerleşke dışında yerinde görerek saha çalışmalarına yer verilmesi, tüm derslerde konuların “peki biz neler yapabiliriz?” yaklaşımıyla sonuçlandırılması böylece öğrenilenlerin günlük yaşantılarına transfer edilmesi olduğu düşünülmektedir. Özetle, iyi bir çevre eğitimiyle öncelikle etkili bir çevre bilincinin kazandırılması hedeflendiğine göre böyle bir eğitim programı ilerde çocuklarımızı eğitecek öğretmenlerimizin hizmet öncesinde bu alanda iyi yetişmelerini sağlayacaktır.

ÖNERİLER

Araştırmadan elde edilen sonuçlar ışığında öğretmenlere ve eğitimcilere aşağıdaki önerilerde bulunulabilir;

Çevre eğitimine yönelik öğretim etkinlikleri planlanırken çevreye yönelik davranışları geliştiren ve kalıcılığını sağlayan uygulamalara yer verilmelidir. Bu kapsamda öğrenci merkezli etkinlikler düzenlenmeli ve grup etkinliklerine önem verilmelidir.

Yeşil Kutu Projesi gibi uygulamaların çevre dostu davranışları geliştirdiği görüldüğü için öğretmen adaylarına benzer kapsamlı ve içerikli eğitimler verilmesi önerilmektedir.

Bu araştırmada çevreye yönelik davranışları artırdığı görülen faktörler eğitimde öne çıkarılmalıdır. Çevre dostu davranışları artıran faktörler açısından bakıldığında bu çalışmadaki öğretim sürecini bir bütün olarak görmek gerekir. Ancak özellikle; çevre bilimi derslerinin dönem boyunca yaparak yaşayarak öğrenme prensibine göre öğrencilerin aktif katılımını sağlayacak şekilde gerçekleştirilmiş olması, uygulamalardaki bazı etkinliklerin kampus dışında yerinde görerek saha çalışmalarına yer verilmesi, tüm derslerde konuların “peki biz neler yapabiliriz?” yaklaşımıyla sonuçlandırılması; böylece öğrenilenlerin günlük yaşantılarına transfer edilmesinin etkili olduğu düşünülmektedir. Bu sebeple, fakültelerde çevre bilimi lisans derslerinde bu faktörler göz önüne alınarak planlama yapılabilir.

Sürdürülebilir bir yaşama yönelik çevre eğitimi aracı olarak da görülen “yeşil kutu” projesinin uygulanması ve değerlendirilmesinin nasıl yapılacağı konusunda öğretmenler ve öğretmen adayları bilgilendirilmelidir.

Öğretmen adaylarının çevre bilinçlerinin artırılması için okulöncesinden başlayan çevre eğitimine ihtiyaç vardır. Özellikle çevre dostu davranışların geliştirilmesi için öğretilmek istenen bilgilerin, daha sonra hangi ortamlarda kullanılacağına öğretilmesi ile mümkün olabilir. Y yaparak yaşayarak öğrenmenin önemi burada ortaya çıkmaktadır. Çünkü yapay ortamlarda öğrenilen bilgilerin gerçek ve karmaşık bir yaşamda kullanılması mümkün olmaz (Gräsel, 1997). Bunun için çevre eğitiminde öğrencilerin duyuşsal alanda, bilişsel alanda ve psikomotor alanında öğrenmeleri sağlanmalı, okul dışında ve doğal ortamda yapılacak etkinliklerle dersler işlenmeli ve çevre sorunları ele alınmalıdır.

Öğretmen adaylarında %26’lık çevre dostu davranışların açıklanmasının gerisinde yatan neden kolay olan davranışlar olduğu düşünülmektedir. Çevre bilincine sahip bireylerin oluşması için öncelikle öğrencilerin çevre merkezli (ekosentrik) tutumlarının güçlendirilmesi için eğitime ağırlık verilmelidir.

Genel olarak çevre bilincine sahip toplumun oluşması için öncelikle kreşlerden başlayarak ilk ve ortaöğretim kurumlarında ve lisans eğitimlerinde çevre dostu davranışlar geliştirecek bir biçimde disiplinler üstü ve tüm öğretmenlerin görev bilinciyle bir çevre eğitimi verilmelidir (De Haan, 1989).

KAYNAKLAR

De Haan, G. (1989). *Ökologie-Handbuch Grundschule-Sieben Themen mit über 100 praktischen Vorschlägen für den Unterricht*. Beltz Verlag. Weinheim und Basel.

Erten, S. (2000). *Empirische Untersuchungen zu Bedingungen der Umwelterziehung –ein interkulturellvergleich auf der Grundlage der Theorie des geplanten Verhaltens*. Tectum Verlag. Marburg.

Erten, S. (2003). *5. Sınıf Öğrencilerinde “Çöplerin Azaltılması” Bilincinin Kazandırılmasına Yönelik Bir Öğretim Modeli*. Hacettepe Üniversitesi Eğitim Fakültesi Dergisi, Sayı 25, 94-103.

Erten, S. (2005). *Okul Öncesi Öğretmen Adaylarında Çevre Dostu Davranışların Araştırılması*. Hacettepe Üniversitesi Eğitim Fakültesi Dergisi, Ankara, Sayı 28; 91-100.

Erten, S. (2011). *Türkiyeli ve Azerbaycanlı Öğrencilerde Ekosentrik, Antroposentrik ve Çevreye Karşı Antipatik Tutum Anlayışları*. Hacettepe Üniversitesi Eğitim Fakültesi Dergisi, Sayı 41: 158-169

Erten, S. (2012). *Türk ve Azeri Öğretmen Adaylarında Çevre Bilinci*. Eğitim ve Bilim, 37-166: 88-100

Gräsel, C. (1997): “Problemorientiertes Lernen“. Göttingen, Bern, Toronto, Seattle

Kaiser, F. G., Wölfling, S., Fuhrer, U. (1996). *Environmental Attitude and Ecological Behavior*. Journal of Environmental Psychology, 19, 1-19.

Keleş, Ö., Uzun N., Uzun F. V. (2010). *Öğretmen Adaylarının Çevre Bilinci, Çevresel Tutum, Düşünce ve Davranışlarının Doğa Eğitimi Projesine Bağlı Değişimi ve Kalıcılığının Değerlendirilmesi*. Electronic Journal of Social Sciences, Cilt.9 Sayı 32: 384-401.

Öztürk, E. (2013). *Uluslar arası Bir Çevre Eğitimi Projesinin Fen ve Teknoloji Öğretmen Adaylarının Çevre Bilinçlerine Etkisi*. Yayımlanmamış Doktora Tezi. Hacettepe Üniversitesi Eğitim Bilimleri Enstitüsü, Ankara.

Palmer, J. A. (1995). *Environmental Education in the 21st Century: Theory, Practice, Progress And Promise*. London: Routledge. 141.

Pooley, J.A, O'Connor, M., (Sep.2000). *Environmental Education and Attitudes*. *Environment & Behavior*, 32(5), 711-724.

Reiss, M. J., J.L.Chapman (1998). *Ecology and Conservation*. Cambridge University Pres.

Tüysüzöğlü, P. (2005). *Yeşil Kutu Türkiye’de Çevre Eğitimi ve Sürdürülebilir Kalkınma için Eğitim Ön Araştırma Raporu*, 10-11.

Yeşil Kutu Eğitim Paketi. (2007). *Öğretmen Kılavuz Kitabı*. REC. Ankara

EXTENDED ABSTRACT

Purpose of the Study: The main purpose of environmental education is to create environmental awareness. By the way, it is thought that environmental awareness; knowledge, behaviors and attitudes that has been gained by prospective teachers, will influence environmental education that they would transfer to the students during their service process. The purpose of the education is to search about the effect of an international environmental education project “Green Pack” on the prospective science and technology teachers’ environmental behaviors.

Methodology: This study is conducted on students who study at science and technology education department of a university on 3rd grade at 2012-2013 academic years. A graduate course “Environmental Science” of Elementary Science Education Department is used during research process. One section of 3rd grade science and

technology education students is accredited to (N=30) whereas the other section is accredited to (N=30) control class. In this study, a model of experimental research design consisting pretest and posttest of experimental and control groups are being used. Data has been collected by Environmental Awareness Scale (EAS) formed by Erten (2000). The instrument contains different tests that measure indicated dimensions as environmental knowledge, behaviors and attitudes. The Cronbach Alpha reliability of the instrument in this research is .82.

Results: According to research, by the end of this education programme environmental behaviors of teacher candidates has been increased by either control or environmental groups, nevertheless the increase in control group is not significant. So, as a result, the environmental education which has been given during the study does not affect prospective teachers in control group. In addition to that, in terms of overall scores of environmental awareness (EAS), there has been no improvement in control group whereas the prospective science and technology teachers who are in the experimental group have shown significant increase. The most important externalized indicator that should be shown by individuals will be the environment friendly behaviors. According to both the data gained during the study, it is obviously presented that the behaviors of prospective teachers have been significantly changed.

Key Words: prospective science and technology teacher, environmental education, environmental behaviours

THE EFFECT OF COMPUTER ASSISTED LABORATORY APPLICATIONS ON PRESERVICE TEACHERS' ATTITUDES TOWARDS SCIENCE TEACHING

Şeyma ULUKÖK

Uğur SARI

The aim of this study is to find out the effects of computer assisted laboratory applications on preservice science teachers' attitudes towards science teaching. The opinions of the preservice teachers about the conducted activities are also aimed to be determined. The sample of the study consists of 46 students studying Science Education at Kırıkkale University's Faculty of Education. These students are junior students who have enrolled for the course "Laboratory Applications for Science Teaching II". The data of the study are obtained after an application that lasts for eight weeks in the second semester of 2012-13 academic year. One sample pretest-posttest design which is one of the experimental methods is used in the study. A semi-structured interview form and the 'Science Attitude Scale' developed by Thompson and Shringley (1986) and adapted to Turkish by Özkan, Tekkaya and Çakıroğlu (2002) are used as data collection tools in this study. The statistical analysis of the obtained data reveals that the computer assisted laboratory applications have significant effects on preservice teachers' attitudes towards science teaching. The analysis result of the qualitative data shows that the preservice teachers generally give positive opinions about the applications.

Keywords: Computer Assisted Teaching, Laboratory Applications, Computer Simulations, Attitudes

RETHINKING THE MEANING OF INTERNATIONAL LARGE-SCALE ASSESSMENT

Tsung-Hau JEN

Kuan-Ming CHEN

The results of large-scale survey of education, for example, PISA and TIMSS, help in inspiring the revolution in education. By using a secondary analysis, the 15-year-olds' performances on mathematics literacy were examined according to their grade levels for ten participant countries of PISA 2012. By treating the confounding variables of mathematics literacy including the SES status, school repetition and the birthday month, as moderators, we argued that the 15-year-old students in a certain grade level and participated in PISA 2012 can be seen as a sample of all the students in the same grade level in the same country. Therefore, the slope coefficient of the grade variable can be seen as the learning progression per year. The results indicate that the learning progression from grade 9 to grade 10 is significant for all the analyzed countries except for Taiwan. The implications of this study will be presented in the conference.

Keywords: PISA, learning progression, mathematics literacy, grade difference

DEVELOPMENT AND VALIDATION OF A SCALE TO MEASURE CHEMISTRY LABORATORY ANXIETY LEVEL OF UNIVERSITY STUDENTS

Assoc. Prof. Dr. N.İzzet KURBANOGLU
Sakarya University Faculty of Education
kurbanoglu@sakarya.edu.tr

Res. Asst. Eren YUCEL
Cumhuriyet University Faculty of Education
eyucel@cumhuriyet.edu.tr

ABSTRACT: The aim of this study is to develop a measuring tool for measuring the anxiety levels of university students for Chemistry Laboratory course. According to this purpose, the validity and reliability study of anxiety scale for Chemistry Laboratory course was carried out. Chemistry Laboratory Anxiety Scale includes 12 items that supporting anxiety. In anxiety scale items were prepared as 5-point Likert type and graded as “Never”, “Rarely”, “Often”, “Usually” and “Always”. Sample of the study has been consisted of 685 science teacher candidate including 235 male and 450 female that studying in three different Faculty of Education, enrolling chemistry and chemistry laboratory courses. Content validity was done by taking decisions of different experts. Explanatory Factor Analyses (EFA) was executed for structural validity of the scale. The results of the EFA showed that scale consisted of one factor. The total variance explained was 45% and factor loadings ranged from .52 to .77. It is found that for all the items in the scale Cronbach alpha is .88 and split half test correlation is .84.

Key words: Chemistry laboratory, anxiety, reliability and validity.

DEVELOPMENT AND VALIDATION OF A SCALE TO MEASURE BIOLOGY LABORATORY ANXIETY LEVEL OF UNIVERSITY STUDENTS

Assoc. Prof. Dr. N.İzzet KURBANOGLU
Sakarya University Faculty of Education
kurbanoglu@sakarya.edu.tr

Res. Asst. Eren YUCEL
Cumhuriyet University Faculty of Education
eyucel@cumhuriyet.edu.tr

ABSTRACT: The aim of this study is to develop a measuring tool for measuring the anxiety levels of university students for Biology Laboratory course. According to this purpose, the validity and reliability study of anxiety scale for Biology Laboratory course was carried out. Biology Laboratory Anxiety Scale includes 15 positive items that supporting anxiety. In anxiety scale items were prepared as 5-point Likert type and graded as “Never”, “Rarely”, “Often”, “Usually” and “Always”. Sample of the study has been consisted of 685 science teacher candidate including 235 male and 450 female that studying in three different Faculty of Education, enrolling biology and biology laboratory courses. Content validity was done by taking decisions of different experts. Explanatory Factor Analyses (EFA) was executed for structural validity of the scale. The results of the EFA showed that scale consisted of one factor. The total variance explained was 53% and factor loadings ranged from .61 to .80. It is found that for all the items in the scale Cronbach alpha is .93 and split half test correlation is .85.

Key words: Biology laboratory, anxiety, reliability and validity.

KNOWLEDGES FOR EFFECTIVE INTEGRATION OF MATHEMATICS AND SCIENCE

Dr Páraic Treacy
NCE-MSTL, University of Limerick, Ireland.
paraic.treacy@ul.ie

Prof. John O'Donoghue,
NCE-MSTL, University of Limerick, Ireland.
john.odonoghue@ul.ie

The level and complexity of knowledge held by a teacher affects what is done in classrooms and, as a consequence, also influences what students learn (Fennema and Franke 1992). Integrating mathematics and science requires the teacher in question to have a certain level of both content knowledge and pedagogical knowledge to educate students in both disciplines successfully (Frykholm and Glasson 2005). Consequently, the knowledges required to effectively instruct students in an integrated setting is a vital element of the successful implementation of such lessons. Research indicates that a teacher's content knowledge in the subjects he/she teaches is of utmost importance, this translates to an integrative setting – content knowledge and pedagogical content knowledge within both mathematics and science must be of a high standard to implement these lessons successfully. This can be achieved through provision of the relevant resources, a working support structure, and teacher training.

Keywords: integration, mathematics, science, knowledges, pedagogy.

INTRODUCTION

The level and complexity of knowledge held by a teacher affects what is done in classrooms and, as a consequence, also influences what students learn (Fennema & Franke, 1992). Integrating mathematics and science requires the teacher in question to have a certain level of both content knowledge and pedagogical knowledge to educate students in both disciplines successfully (Frykholm & Glasson, 2005). Consequently, the knowledges required to effectively instruct students in an integrated setting is a vital element of the successful implementation of such lessons. This piece of writing will investigate the knowledges required to teach effectively during lessons which integrate mathematics and science by considering research conducted in this field and applying it to the preparation required of teachers prior to implementing lessons which integrate mathematics and science in classroom.

Such an understanding of the knowledges required to integrate mathematics and science was developed by the author in order to successfully implement a new teaching model for integrating mathematics and science in second level classrooms. This new model, entitled 'Authentic Integration', caters for the specific needs of integration of mathematics and science as it requires that each lesson be based around a rich task which relates to the real world, explores concepts from both subjects, and ensures that hands-on group work, inquiry and discussion are central to the lesson (Treacy, 2012). This model was applied in four post-primary schools in Ireland. Understanding the knowledges required to effectively integrate mathematics and science in the classroom proved to be vital in the overall success of the intervention. The development and implementation of this understanding is discussed in this article as well as its contribution to the efficient execution of the lessons.

KNOWLEDGES FOR EFFECTIVE TEACHING

Shulman's (1986) work was the first foray into the area of knowledges for effective teaching and provided a base for the work which was to follow from the likes of Ernest (1989), Fennema and Franke (1992), and Rowland et al. (2005). Shulman (1986) identified three domains when constructing his model:

- Subject Matter Content Knowledge
- Pedagogical Content Knowledge
- Curricular Knowledge.

He believed that 'Subject Matter Content Knowledge' was the most important of the three, claiming that teachers must have a deep understanding of the content in order to teach it effectively (Shulman 1986). This is

an important issue when considering integration of mathematics and science as, depending on the approach taken, it may require one teacher to educate pupils in mathematics and science simultaneously (Jacobs, 1989). If this occurs then the teacher must, according to Shulman (1986), possess a decent depth of knowledge within both subjects.

‘Pedagogical Content Knowledge’ refers to the repertoire of representations of the content that a teacher draws on to aid pupils in comprehending the subject matter. These could be demonstrations, examples, analogies or illustrations which help pupils form a greater understanding of what is being examined (Shulman 1986). In other words, it is the ability of a teacher to draw on various exemplifications of the given content to enhance the quality of their instruction so as to ensure a greater depth of understanding amongst the pupils. An example of this could be the use of a balance scales to explain procedures adopted when solving mathematical equations. With a balance scales, if a weight is added to one side then a weight of the same magnitude must be added to the other side to maintain balance. It is the same with equations: if a number is added to one side of the equation then the same number must be added to the other side of the equation to ‘maintain balance’. This offers a concrete example which pupils can recognise and refer to, thus improving understanding of the concept.

‘Curricular Knowledge’ refers to knowledge and competency in relation to the range of programmes and materials available to the teacher with regards to a particular subject or topic. It refers to the knowledge of the various ways an educator can teach elements of the curriculum to their pupils and the educator’s recognition of which way is best in given situations (Shulman 1986). In other words, this element refers to the notion that there is more than one way to teach a topic or subject and a teacher should have a certain level of expertise in the various approaches which could be deployed as well as knowing when best to deploy them.

Schulman’s (1986) work was not subject specific hence it was aimed at encompassing all teaching. It formed the key reference for subsequent attempts at modelling subject specific and non-subject specific knowledges for effective teaching. As the issue of knowledges for effective teaching began to develop, more authors offered theories in relation to its make-up. Two of these authors, Ernest (1989) and Fennema & Franke (1992) lead the way in defining the knowledge make-up of effective mathematics teachers, leading onto Rowland et al. (2005) and their work on the ‘Knowledge Quartet’.

KNOWLEDGES FOR EFFECTIVE MATHEMATICS TEACHING

Following Shulman’s (1986) ground-breaking work, academics began to apply his theory to specific subjects with Ernest (1989) developing one of the first models of teacher knowledges for effective mathematics teaching. This model was quite detailed, outlining the knowledges, beliefs and attitudes vital for effective mathematics teaching. Similar to Shulman (1986), Ernest (1989) highlighted subject content knowledge, i.e. knowledge of mathematics, as the most important element. When Fennema and Franke (1992) published their model of knowledges for effective mathematics teaching, content knowledge was also identified as the most vital characteristic. This aspect continues to be regarded as being of the utmost importance in present day models of this nature.

Surprisingly, content knowledge has been shown to be negatively related to the use of inquiry-based classroom instruction and to beliefs in the effectiveness of such instruction (Wilkins, 2008). Many teachers with strong content knowledge tend to rely on ‘traditional’ methods i.e. focus on rules and procedures (Mewborn, 2001). It is, rather, positive attitudes towards the subject that facilitate the adoption of inquiry-based instruction in the classroom (Karp, 1991; Wilkins, 2008). These findings show that content knowledge is of great importance for effective mathematics instruction but must be supplemented with positive beliefs in relation to inquiry-based instruction if such an approach is to be adopted.

Returning to the aforementioned models: interestingly, the knowledge characteristic which Ernest (1989) terms as the next most important, ‘Knowledge of Other Subject Matter’, is an endorsement of the assimilation of mathematics with other subjects. Ernest (1989, p.17) claims that knowledge of other subject matter “provides a stock of knowledge of uses and applications of mathematics” which he believes forms an important contribution to the teaching of mathematics. Similarly, Rowland et al. (2005) cited such a characteristic in his ‘Knowledge Quartet’ model – ‘Connection Knowledge’. This aspect deals with the knowledge required to make connections within mathematics i.e. between concepts and/or procedures; and between mathematics and other subjects or disciplines (Rowland et al., 2005). As such, the ‘Knowledge Quartet’ may lend itself to underpinning the knowledges required to effectively integrate mathematics and science in the classroom.

The Knowledge Quartet

The 'Knowledge Quartet' provides the most recent widely endorsed version of what knowledges it takes to be an effective mathematics teacher. Again, Mathematical knowledge tops the list of most important characteristics; within the quartet it is referred to as 'Foundation Knowledge'. But there is one important difference in the definition of this aspect compared to previously mentioned models – it not only includes knowledge of mathematics itself but also the beliefs which the teacher holds in relation to mathematics, and it is upon this foundation that the other characteristics of the model are built (Rowland et al. 2005). This is significant due to the observation, discussed earlier, that although content knowledge is vital for effective teaching, beliefs determine whether innovative practices such as active and experiential learning are adopted (Wilkins 2008, Karp 1991). Thus, if an innovation like the integration of mathematics and science is to be adopted, 'Foundation Knowledge' within teachers, which encompasses the desirable beliefs and levels of mathematical knowledge, would be a cornerstone of its implementation. The significance of this to the author is the realisation that an effective implementation of an integrative framework would require training for teachers to ensure they have the required content knowledge but also, possibly more importantly, it would require teachers to 'buy into' the approach being used i.e. hold the belief that experiential and active learning is a worthwhile endeavour.

Next in the Knowledge Quartet is 'Transformation Knowledge' which is very similar to Shulman's (1986) 'Pedagogical Content Knowledge' described earlier. In essence this characteristic separates those who know mathematics from those who know how to teach mathematics. This leads into the third element of the 'Knowledge Quartet' – 'Connection Knowledge' which, as discussed earlier, is the knowledge required to make connections within mathematics i.e. between concepts and/or procedures; and between mathematics and other subjects or disciplines (Rowland et al. 2005). The ability to make connections to areas within and outside mathematics is of course an essential element of integration of mathematics with other subjects thus it is imperative that teachers pursuing an integrative approach have this characteristic.

Finally, within Rowland et al.'s (2005) 'Knowledge Quartet', 'Contingency Knowledge' which describes a teachers ability to adjust to unexpected situations such as an unforeseen circumstance, or a question which had not been anticipated. It also alludes to a teacher's recognition of when and how a lesson needs to be adjusted from the original lesson plan if required (Rowland et al., 2005). Once again, this is quite relevant to issues relating to integration of mathematics and science, as a teacher's ability to think on their feet is essential in an active or experiential lesson as there is a great element of discovery learning involved which can go down various paths thus calling on the teacher to be able to adjust and react to various scenarios and questions, some of which could (and probably will) be unanticipated.

KNOWLEDGES FOR EFFECTIVE SCIENCE TEACHING

Research into the knowledges required to effectively teach science produced similar findings to those outlined previously i.e. a teacher's content knowledge plays a pivotal role in the depth of learning achieved by their students as well as the manner in which they learn in the classroom. Science teachers with well-developed levels of content knowledge ask more questions while there is a greater probability that their students will consider alternative explanations, propose more investigations, and embark on unanticipated inquiries compared to teachers with weaker content knowledge (Alonzo, 2002; Sanders, Borko, & Lockard, 1993). Teachers with poor content knowledge tend to teach in a more direct manner, telling the students the content rather than allowing them to develop their own understanding through inquiry (Alonzo, 2002; Sanders et al., 1993). Consequently, it is clear that the greater content knowledge a teacher has, the more they are open to holistic approaches to tuition in which students explore topics and concepts, by which they develop their own meaning and understanding.

Pedagogical content knowledge (PCK) has previously been flagged as an important part of the range of knowledges a teacher possesses in both typical tuition (Shulman, 1986) and in a setting which integrates mathematics and science (Frykholm & Glasson, 2005). Greater focus has been placed on PCK recently by those researching knowledges for effective science teaching with Loughran et al. (2012) exploring the PCK of science teachers held in high-regard to gain a greater insight into how this translates into their teaching. This research clearly indicated the importance of in-depth understanding of PCK as Loughran et al. (2012) regularly observed that the knowledge of practice which science teachers relied upon and the manner in which they conceptualised science content in the classroom was a clear indicator of whether or not a teacher could be termed as being expert in their field.

BUILDING TEACHERS' KNOWLEDGES FOR EFFECTIVE INTEGRATION OF MATHEMATICS AND SCIENCE

Analysis of the knowledges required for effective instruction indicates that content knowledge is a vital characteristic of successful educators. Content knowledge, characterised in one way or another, was labelled the most important aspect of all the models outlined (Ernest, 1989; Fennema & Franke, 1992; Rowland et al., 2005). It is of great importance to find ways to counteract any gaps in knowledge within mathematics and/or science amongst teachers prior to attempting an integrative approach. One solution to this would be for teachers of each subject to work in tandem i.e. team teach a lesson. This would probably be an unrealistic aim for schools that typically follow a set timetable as both teachers would need to be free to work at the same time with one class.

Another solution would be to conduct the mathematics aspect of the intended problem or project during the mathematics lesson and the science aspect during the science lesson. Such an approach may be possible for certain problems or projects but for most lessons it would most likely negatively affect the learning that takes place in the lesson and could greatly reduce the integrative element of the lesson and any positives that come with that.

A third solution, and probably the most practical one, would be to up-skill the teachers in relation to the knowledge gaps they have i.e. improve the mathematics teachers' science content knowledge and pedagogical content knowledge in relation to the material which would come up in each lesson they are to teach, and vice versa. In other words, give them the knowledges they require to deal with any questions from the pupils and to successfully use various representations and exemplifications of concepts in both disciplines to effectively aid student understanding.

In summation, with this close look at knowledges for effective teaching, it is clear that work must be done with teachers prior to an implementation of an integrative framework. Work must be carried out on the level of content knowledge they possess in both mathematics and science, while also developing their pedagogic content knowledge within both subjects to enhance the manner in which they guide the pupils' learning. Such an approach was taken to provide a basis for integration of mathematics and science during the author's intervention.

APPLYING IMPROVED TEACHER KNOWLEDGES FOR INTEGRATION OF MATHEMATICS AND SCIENCE

The requirement for teachers to have a working knowledge of both mathematics and science can obstruct the implementation of integrative lessons as teachers may be aware of how the subjects connect but may not have the expertise or the confidence to carry through these connections into their teaching:

“[O]bviously I'd be aware of the link [between the subjects], but it took someone to point it out for me to actually explain it perfectly to the students.”

Jennifer Collins (mathematics teacher)
(Treacy, 2012)

Later in the interview she confirmed this anxiety:

“At the start I was a bit apprehensive about how I'd incorporate it into my teaching, how I'd put the whole lesson across and would I be able to achieve what I was hoping to. But as I got into it, and the resources were brilliant that I was provided with, and it was laid out so well that it was easy to follow and deliver the lesson to the students. I really enjoyed it. It also gave me an awakening; it showed me how you can teach a topic in different ways and integrate it with something else.”

Jennifer Collins (mathematics teacher)
(Treacy, 2012)

The author, due to the careful consideration of the nature of knowledges for effective teaching outlined previously, anticipated that this would be an important element within this research and thus ensured that each teacher would have the requisite level of knowledge within both mathematics and science prior to implementing the lessons by providing plenty of resources as well as teacher training. Focus was placed on content knowledge and pedagogical content knowledge in both mathematics and science.

This support system – which included electronic presentations on all the topics, teacher training, availability of the lead researcher for assistance – evidently proved to be quite important in ensuring that teachers were comfortable in implementing the lessons. Collins (mathematics teacher) had some anxiety in relation to her ability to teach lessons which incorporated both mathematics and science, as stated above, but made use of the resources and training available which gave her the confidence to conduct the integrative lessons.

It proved not to be a stumbling block for the other teachers involved in this project as each of them found the content to be very manageable and none voiced any problems grasping elements that they weren't previously overly familiar with. In fact, the participants gained great benefit from combining the subjects:

“I think it worked very, very well. From my own point of view, there's a lot I didn't know – some of the definitions in science... there's a lot I didn't know myself and they're very maths related. So I think there's so many areas in science that are related to maths and I think it'll come through with the project maths type of questions that are coming in”.

Martina O'Reilly (mathematics teacher)
(Treacy, 2012)

O'Reilly gained a greater insight into elements of science that mathematics could be related to and envisions the benefits that this will provide for her when adapting to the new 'Project Maths' syllabus which was being introduced in Ireland at the time of the intervention.

CONCLUSION

Students learn more from teachers who are skilled, experienced, and know what and how to teach (Darling-Hammond, 2000; Goldhaber, 2002; Rice, 2003). A teacher may tick all these boxes when it comes to his/her specialised subject but the adoption of an additional subject within their classroom setting provides a further challenge. This is because their content knowledge, which is the best indicator of an effective teacher (Shulman 1986), and/or pedagogical content knowledge within that auxiliary subject might not be of the required standard.

At the commencement of the aforementioned intervention, some of the teachers, i.e. those not specialised in both mathematics and science, displayed some anxiety and indicated their trepidation regarding their lack of content knowledge within their non-specialist subject. The allocation of teacher training and the support structure put in place for this investigation allowed them to develop their content knowledge and pedagogical content knowledge within the topics they studied with the pupils through the lessons. It became clear as the study progressed, and through interviews with the teachers, that such development of knowledges was a vital element in the success of the lessons.

As such, research indicates that a teacher's content knowledge and pedagogical content knowledge in the subjects he/she teaches is of utmost importance. This also translates to an integrative setting – content knowledge and pedagogical content knowledge within both mathematics and science must be of a high standard to implement these lessons successfully. As shown in this study, this can be achieved through provision of the relevant resources, a working support structure, and teacher training.

REFERENCES

- Alonzo, Alicia. (2002). *Evaluation of a Model for Supporting the Development of Elementary School Teachers' Science Content Knowledge*. Paper presented at the Annual International Conference of the Association for the Education of Teachers in Science, Charlotte, NC.
- Darling-Hammond, L. (2000). Teacher quality and student achievement: A review of state policy evidence *Education Policy Analysis Archives* (Vol. 8).
- Ernest, P. (1989). The Knowledge, Beliefs and Attitudes of the Mathematics Teacher: A Model. *Journal of Education for Teaching*, 15(1), 13-33.
- Fennema, E., & Franke, M.L. (1992). Teachers' knowledge and its impact. In D. A. Grouws (Ed.), *Handbook of Research on Mathematics Teaching and Learning* (pp. 147-164). New York: McMillan.
- Frykholm, J., & Glasson, G. (2005). Connecting Science and Mathematics Instruction: Pedagogical Context Knowledge for Teachers. *School Science and Mathematics*, 105(3), 127-141.
- Goldhaber, D. (2002). The mystery of good teaching: Surveying the evidence on student achievement and teacher characteristics. *Education Next*, 2(1), 50-55.

- Jacobs, H.H. (1989). The growing need for interdisciplinary curriculum content. In H. H. Jacobs (Ed.), *Interdisciplinary Curriculum: Design and Implementation* (pp. 1-13). Alexandria, Virginia: Association for Supervision and Curriculum Development.
- Karp, K.S. (1991). Elementary school teachers' attitudes toward mathematics: The impact on students' autonomous learning skills. *School Science and Mathematics, 91*(6), 265-270.
- Loughran, J John. (2012). *Understanding and Developing Science Teachers' Pedagogical Content Knowledge* (Vol. 12): Springer.
- Mewborn, D. (2001). Teachers content knowledge, teacher education, and their effects on the preparation of elementary teachers in the United States. *Mathematics Education Research Journal, 3*, 28-36.
- Rice, J.K. (2003). *Teacher quality: Understanding the effectiveness of teacher attributes*. Washington, D.C.: Economic Policy Institute.
- Rowland, T., Huckstep, P., & Thwaites, A. (2005). Elementary teachers' mathematics subject knowledge: The knowledge quartet and the case of Naomi. *Journal of Mathematics Teacher Education, 8*(3), 255-281.
- Sanders, Linda R, Borko, Hilda, & Lockard, J David. (1993). Secondary science teachers' knowledge base when teaching science courses in and out of their area of certification. *Journal of Research in Science Teaching, 30*(7), 723-736.
- Shulman, L.S. (1986). Those who understand: Knowledge growth in teaching. *Educational researcher, 15*(2), 4-14.
- Treacy, P. (2012). *An Investigation into the Integration of Mathematics and Science at Junior Cycle in Irish Post Primary Schools*. (Doctorate), University of Limerick. Retrieved from <http://hdl.handle.net/10344/2855>
- Wilkins, J.L.M. (2008). The relationship among elementary teachers' content knowledge, attitudes, beliefs, and practices. *Journal of Mathematics Teacher Education, 11*(2), 139-164.

AN AUTOMATED SCORING APPROACH FOR ESSAY QUESTIONS

Ahmed Alzahrani
University of Essex
araalz@essex.ac.uk

Abdulkareem Alzahrani
University of Essex
aalza@essex.ac.uk

Fawaz Alarfaj
University of Essex
falarf@essex.ac.uk

Khalid Almohammadi
University of Essex
kszalm@essex.ac.uk

Malek Alrashidi
University of Essex
mqaalr@essex.ac.uk

ABSTRACT: The automated scoring or evaluation for written student responses have been, and are still a highly interesting topic for both education and natural language processing, NLP, researchers alike. With the obvious motivation of the difficulties teachers face when marking or correcting open essay questions; the development of automatic scoring methods have recently received much attention. In this paper, we developed and compared number of NLP techniques that accomplish this task. The baseline for this study is based on a vector space model, VSM. Where after normalisation, the baseline-system represents each essay by a vector, and subsequently calculates its score using the cosine similarity between it and the vector of the model answer. This baseline is then compared with the improved model, which takes the document structure into account. To evaluate our system, we used real essays that submitted for computer science course. Each essay was independently scored by two teachers, which we used as our gold standard. The systems' scoring was then compared to both teachers. A high emphasis was added to the evaluation when the two human assessors are in agreement. The systems' results show a high and promising performance.

Keywords: Automated Essay Scoring, Project Essay Grade, E-Pedagogy and E-Assessment.

INTRODUCTION

The essays examinations are basically considered as an indispensable key in the educational processes. It helps instructors to know students achievements and their situations during the learning journey. Even more, they are considered as a measurement of the learner's ability to memorise, organise, analyse, and write thoughts focusing on specific desirable goals. In perspective aspects, the essay examination advantageously suits the small number of candidates as this gradually decreases when the number becomes larger. Furthermore, it eliminates the candidate's guessing, since it relies on his free answer rather than selecting the good answer such as in multiple choices tests.

However, when there is a vast number of examinations that need to be assessed at once, the instructor finds himself overwhelmed to provide high quality feedback to educators within as short a period of time as is reasonable. Furthermore, different instructors of such a module can have various feedback scores for one candidate, which is one of the essays examinations drawbacks commonly known as subjectivity (Nitko, 1996). As a result, the advancement in technological systems, especially natural language processing (NLP), is increasingly flourishing into to reduce effort, time, and cost of institution resources, for example the Intelligent Essay Assessor (IEA) (Landauer, 2003), which uses Latent Semantic Analysis (LSA) to extract semantic similarity of words and passages from text. However, this kind of system, based on (LSA) tends more towards the frequency of terms rather than understanding the meaning of human knowledge (language).

To address this issue, an automated scoring system based on vector space models (VSMS) is applied in this paper. Using this model we address the issues of the aforementioned approaches and attempt to exploit the different NLP techniques to come up with an optimal solution.

In the remainder of this paper we demonstrate our system development, in five parts. The first part describes related work. In the second section, a methodology is described. The results and findings are presented in the third section. Section four has been dedicated to drawing conclusion following some recommendations for the future work.

LITERATURE REVIEW

Automated Essay Scoring (AES) is defined as the computer technology that enables us to evaluate and score the written prose (Shermis & Barrera, 2002; Shermis & Burstein, 2003; Shermis, Raymat, & Barrera, 2003). The aim of using AES is to tackle the issues related in writing assessments, such as: time, cost, generalisability and reliability (Burstein, 2003; Chung & O'Neil, 1997; Hamp-Lyons, 2001; Ellis Batten Page, 2003; Rudner & Gagne, 2001; Rudner & Liang, 2002; Sireci & Rizavi, 2000). The advantages of using AES have been attracting public schools, universities and researchers (Burstein et al., 1998; Shermis & Burstein, 2003; Sireci & Rizavi, 2000). Some of these advantages are: relieve the grading burden from the educators and adding a consistent level that unachievable sometimes by educators (Shermis & Barrera, 2002).

Nowadays, there are more than 12 programs in the Project Essay Grade (PEG) and Automated Essay Scoring field. These projects have been influenced by Page work(1966) (Williamson, 2009). In addition, they focus as much on assessing the essays' semantic relevance to a given prompt as on assessing the quality of the essay itself. Some of the popular programs are; the Educational Testing Services (ETS) e-Rater (Attali & Burstein, 2006), PearsonKTs KAT Engine, Intelligent Essay Assessor (IEA) (Landauer, Laham, & Foltz, 2003) and Vantage Learnings Intellimetric (Elliot, 2003).

The e-Rater engine marks writing essays by extracting a set of features representing important aspects of writing quality from each essay. It is based on a regression-based methodology, which is a number of properties derived from natural language processing (NLP). When the regression weights are determined for those properties, they can be employed to more essays to turn a predicted score out based on the calibrated feature weights. The on-going version of e-Rater system uses 10 such regression properties, with eight representing factors of writing quality and two representing content. A set of such sub-features computed from NLP techniques composes of primary scoring features (Attali & Burstein, 2006; Burstein, 2003).

PearsonKT's KAT Engine is a similar application which uses a Latent Semantic Analysis technique (Landauer, Foltz, & Laham, 1998). This technique uses a dimensionality-reduction method based on singular-value decomposition. This method represents the content of each essay as a vector. They use direction and length as two aspects of the computed vector which define the location of the essay in this multi-dimensional space. Then, the content score is calculated as a weighted sum, after normalisation and regression. The essay vector is compared to pre-scored essays by the angle separating. They select the closest pre-scored essays in angle, then take their average human scores, and then the cosine distance from the candidate essay is calculated to produce the direction value. The content score is the combination of the weighted sum with a vector length value of the essay. Finally, they combined this content score with other linguistic measures such as style and mechanics (e.g. spelling) features to produce the resultant essay score (Landauer et al., 2003).

Vantage Learning's IntelliMetric is used to evaluate students' essays as part of intelligent tutoring system (Kukich, 2000). As a consequence of a wide range of applications that are used for automated assessment to essays, these systems concentrate on assessing the semantic relevance or topicality of essays. The IntelliMetric is a scoring engine that assesses the skills of student's essays. The aim of this system is to mark the students writing based on the state achievement examinations. This approach, as other systems, uses a substantial number of computer-produced features, which are designed to represent different aspects of writing quality. Moreover, they use five main classes to aggregate these features. The classes are as follows: Focus/Coherence, Organisation, Elaboration/Development, Sentence Structure, and Mechanics/Conventions. Finally, the multiple concurrent statistical methods are used for aggregating the features in order to give the final score (Elliot, 2003; Learning, 2003; Rudner, Garcia, & Welch, 2006).

Similarity within the text is a fundamental and essential research topic within the processing of the natural language as well as the similarity measure of the variation of physical units. Many researchers have conducted the evaluation of the students' essays upon the matching between the model's and optimal answer and the candidate's answer. It is essential to emphasise the simplicity of the vector space model (VSM), yet effective techniques are needed to determine the similarities between documents or utterances. Such method has been widely used within the educational testing field .VSM technique has been applied by Attali & Burstein (2006) for the purpose of measuring English writers that are non-native in terms of the choice of vocabularies. This technique, which is used during the students' essay, are scored through determining the relationship between the words that exist within a student's answer with the words that are contained within sample essays originating from individual scoring categories. A theory of this method is that outstanding essays would have higher similarity in the choice of words being used. This is especially true when two VSM-derived characteristics were utilised that includes the maximum cosine similarity as well as the cosine similarity related to the top scoring category. Furthermore, this technique has been used by Higgins et al. (2006) in order to discover the off-topic essays by students, though comparing the word based IV originating from an essay to an RV built from a series of essays that are on-topic. The essay is considered to be off-topic if the difference is more significant compared

with a pre-defined threshold. Zechner and Xi (2008) also used VSM to assess whether content was relevant or not when marking work by non-native English speakers, while Xie et al. (2012) examined the viability of VSM methods for automated speech grading. They used a more advanced ASR than Zechner and Xi, and determined that the VSM results correlated quite highly with human scores. This study aims to expand on the scope of existing studies by employing the cosine similarity

METHODS

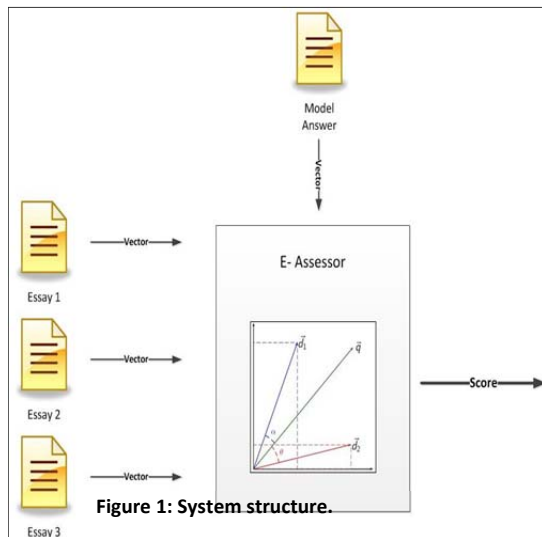

Firstly, we defined the language based on the model answer and created a vector for each subject area. Subsequently these vectors are compared with each student submission to get the automated result (Figure 1).

Before creating the model answer vector we run the standard NLP normalisation techniques including removing stop-word (Figure 2).

a an and are as at be by for from
has he in is it its of on that the
to was were will with

Figure 2: An example of 25 semantically non-selective stop words. Manning et al. (2009)

Removing such words before processing reduced the noise from the collection and helped to increase the accuracy of the system. Moreover, it helps in the computational process, as we will be dealing with much smaller vectors.

We expand the result text by electing the most relevant synonyms for each word to be including in the composed vector. This step is crucial to capture a higher level of semantic. Therefore, if the same concept is formulated using different words, it still is considered toward the correct answer. The WordNet¹ lexical database is used within the normalisation engine to extract the synonyms.

Finally, we normalise result texts by converting each word to its base form. Thus words like *organise*, *organizes*, and *organising* would be mapped to the same element in our vector. This will help in comparing the students' work to the model answer as they may use different forms of the same word to express the same idea. To accomplish this task we apply Porter's algorithm. We found that the aforementioned steps would greatly increase the accuracy of the results.

We emphasise on this where we examine the similarity of each part of the document separately, before calculating the full document similarity. This approach helps the problem faced when marking the documents organisation, not only the document content. At this stage we consider only three parts of the document, the abstract, document body, and the conclusion. We use these parts as they are clearly mentioned in the question description. We used a linear function for combining these similarities with weighting factors for each part.

EXPERIMENT AND RESULTS

To test our approach, we selected eight essays from two different knowledgeable areas. Each essay was assigned to two independent human assessors to mark it. The human marks are then compared with the marks generated by our systems.

	Knowledge area 1				Knowledge area 2			
Essay number	1	2	3	4	5	6	7	8
<i>hVec</i>	56	57	38	62	63	57	66	54
<i>mVec</i>	73	79	69	72	80	77	88	82
<i>humanAvg</i>	86	88	62	65	82	80.5	73.5	84.5

Table 1: Results summary.

¹ <http://wordnet.princeton.edu>

Two automated runs are computed: 1) *hVec*, where we use one vector to represent the model document and the students essays. 2) *mVec*, where we represent each document with multi vectors, one vector for each part of the document.

We compared both automated runs with the average of the two human marks, *humanAvg* (Table 1). As can be seen in (Figure 3) the multi vector model, *mVec*, is much closer to human judgment, which gives a more reliable and accurate indication.

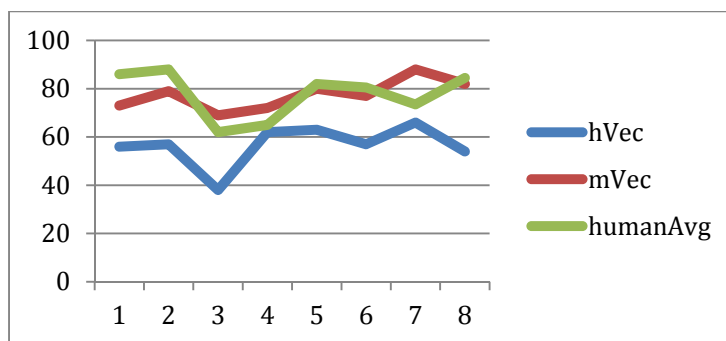

Figure 3: System results.

CONCLUSION

This paper has given an account of, and the view for the widespread use of automated scores techniques. In this investigation, the aim was to assess the methods used in the automated scoring systems. Our system showed that normalisation and taking document structure into account gave a noticeable improvement in the results. The normalisation process was an important factor, which reduced noise in our data. Using document structure to compare with model answers instead of evaluating the whole document at once resulted in an increasing accuracy. For future work, we plan to improve our approach by investigating more ways to represent the document structure. We also plan to apply our methodology in different languages (e.g. Arabic).

REFERENCES

- Attali, Y., & Burstein, J. (2006). Automated essay scoring with e-rater® V. 2. *The Journal of Technology, Learning and Assessment*, 4(3).
- Burstein, J. (2003). The E-rater® scoring engine: Automated essay scoring with natural language processing.
- Burstein, J., Kukich, K., Wolff, S., Lu, C., Chodorow, M., Braden-Harder, L., & Harris, M. D. (1998). Automated scoring using a hybrid feature identification technique. In *Proceedings of the 17th international conference on Computational linguistics-Volume 1* (pp. 206–210). Association for Computational Linguistics.
- Chung, G. K., & O'Neil, H. F. (1997). *Methodological approaches to online scoring of essays*. Citeseer.
- Elliot, S. (2003). IntelliMetric: From here to validity. *Automated Essay Scoring: A Cross-Disciplinary Perspective*, 71–86.
- Hamp-Lyons, L. (2001). Fourth Generation Writing. *On Second Language Writing*, 117.
- Higgins, D., Burstein, J., & Attali, Y. (2006). Identifying off-topic student essays without topic-specific training data. *Natural Language Engineering*, 12(2), 145–159.
- Kukich, K. (2000). Beyond automated essay scoring. *IEEE Intelligent Systems*, 15(5), 22–27.
- Landauer, T. K. (2003). Automatic essay assessment, 10(3), 295–308.
- Landauer, T. K., Foltz, P. W., & Laham, D. (1998). An introduction to latent semantic analysis. *Discourse Processes*, 25(2-3), 259–284.
- Landauer, T. K., Laham, D., & Foltz, P. W. (2003). Automated scoring and annotation of essays with the Intelligent Essay Assessor. *Automated Essay Scoring: A Cross-Disciplinary Perspective*, 87–112.
- Learning, V. (2003). How does IntelliMetric score essay responses. *RB-929*. Newtown, PA: Author.
- Nitko, A. J. (1996). *Educational assessment of students*. ERIC.

- Page, E. B. (1966). The imminence of... grading essays by computer. *Phi Delta Kappan*, 238–243.
- Page, E. B. (2003). Project essay grade: PEG. *Automated Essay Scoring: A Cross-Disciplinary Perspective*, 43–54.
- Rudner, L. M., & Gagne, P. (2001). *An overview of three approaches to scoring written essays by computer*. ERIC Clearinghouse on Assessment and Evaluation.
- Rudner, L. M., Garcia, V., & Welch, C. (2006). An evaluation of IntelliMetric™ essay scoring system. *The Journal of Technology, Learning and Assessment*, 4(4).
- Rudner, L. M., & Liang, T. (2002). Automated essay scoring using Bayes' theorem. *The Journal of Technology, Learning and Assessment*, 1(2).
- Shermis, M. D., & Barrera, F. D. (2002). Exit Assessments: Evaluating Writing Ability through Automated Essay Scoring.
- Shermis, M. D., & Burstein, J. C. (2003). *Automated essay scoring: A cross-disciplinary perspective*. Routledge.
- Shermis, M. D., Raymat, M. V., & Barrera, F. (2003). Assessing Writing through the Curriculum with Automated Essay Scoring.
- Sireci, S. G., & Rizavi, S. (2000). Comparing Computerized and Human Scoring of Students' Essays.
- Williamson, D. M. (2009). A framework for implementing automated scoring. In *Annual Meeting of the American Educational Research Association and the National Council on Measurement in Education, San Diego, CA*.
- Xie, S., Evanini, K., & Zechner, K. (2012). Exploring content features for automated speech scoring. In *Proceedings of the 2012 Conference of the North American Chapter of the Association for Computational Linguistics: Human Language Technologies* (pp. 103–111). Association for Computational Linguistics.
- Zechner, K., & Xi, X. (2008). Towards automatic scoring of a test of spoken language with heterogeneous task types. In *Proceedings of the Third Workshop on Innovative Use of NLP for Building Educational Applications* (pp. 98–106). Association for Computational Linguistics.

LİSE ÖĞRENCİLERİNİN NÜKLEER ENERJİ HAKKINDAKİ BİLGİ DÜZEYLERİ

KNOWLEDGE LEVELS OF HIGH SCHOOL STUDENTS ABOUT NUCLEAR ENERGY

Burcu ANILAN
Eskişehir Osmangazi Üniversitesi, Eğitim Fakültesi
burcud@ogu.edu.tr

Mustafa Zafer BALBAĞ
Eskişehir Osmangazi Üniversitesi, Eğitim Fakültesi
zbalbag@ogu.edu.tr

ÖZET: Enerji kavramı ve enerji kaynaklarının sürdürülebilirliği geçmişten bugüne dünyanın en önemli konularından ve sorunlarından biri olmuştur. Dünya enerji üretiminde öncelikli kaynaklar; petrol, doğalgaz ve kömür gibi yenilenemeyen enerji kaynaklarıdır. Farklı dönemlerde bu enerji kaynaklarından bazıları daha ön plana çıkmıştır. Günümüzde ise enerji ihtiyacı gün geçtikçe artmakta ve mevcut enerji kaynakları bu gereksinimi karşılamakta yetersiz kalmaktadır. Bu bağlamda enerji kaynakları içerisinde nükleer enerji, enerji sorununun çözümünde alternatif bir kaynak olarak görülmektedir. Nükleer enerji gerekli güvenlik önlemleri alındığında çevreye en az zarar veren enerji türlerinden birisi olarak kabul edilmektedir. Buna bağlı olarak yeni yetişen neslin bu konudaki bilgi düzeylerinin belirlenmesi önem taşıdığından lise öğrencilerinin nükleer enerji hakkındaki görüşleri belirlenmeye çalışılmıştır. Bu araştırma betimsel tarama türünde bir araştırmadır. Araştırmaya Eskişehir il merkezinde üç farklı lisede öğrenim gören 409 öğrenci katılmıştır. Araştırmanın verileri anket formu ile toplanmıştır. Elde edilen veriler SPSS paket programı yardımıyla bilgisayarda çözümlenerek yorumlanmış ve bu doğrultuda öneriler geliştirilmiştir.

Anahtar sözcükler: nükleer enerji, lise öğrencileri, bilgi düzeyleri

ABSTRACT: The concept of energy and sustainability of energy resources has been one of the most important issues and problems of the world from the past to present. The primary source of world energy production; oil, gas and coal are non-renewable energy sources. Some of these energy sources in different periods than has been in the forefront. Today, energy needs are increasing day by day and the current energy sources are insufficient to meet this requirement. In this context, nuclear energy in the energy sources is seen as an alternative source for in the solution of the energy problem. Nuclear energy is considered one of the least environmentally damaging forms of energy taking the necessary safety precautions. Accordingly, growing a new generation of knowledge levels on this subject is important to determine the levels of high school students were studied to determine their views on nuclear energy. This research is a study in the descriptive type. Research in three different schools in the city of Eskişehir studying 409 students participated. Research data were collected through a questionnaire. The data obtained with the help of SPSS software program on the computer and interpreted by analyzing proposals have been developed in this direction.

Key words: nuclear energy, high school students, knowledge levels

GİRİŞ

Enerji, çağımızın en önemli tüketim ihtiyaçlarından biri ve vazgeçilmez bir uygarlık aracıdır. Gelişmişlik düzeyi yüksek ülkelerin en önemli ihtiyaçlarının başında gelen enerji tüketimi, sürekli artmakta ve bu artış gelecekte de devam etmektedir (Uyar 2001). Yaşamımızı sürdürürken hayatımızı kolaylaştıran, günlük yaşantımızda kullandığımız cihazlar sürekli enerjiye ihtiyaç duyarlar. Gerekli olan bu enerjinin elde edilmesi için çeşitli kaynaklar kullanılmaktadır. Bu enerji kaynakları, yenilenebilir ve yenilenemeyen enerji kaynaklarıdır. Yenilenebilir enerji, doğada var olan ve sürekli kendini yenileyen enerji kaynağı demektir. Hidroelektrik enerji, rüzgâr enerjisi, güneş enerjisi, jeotermal enerji, biokütle enerjisi, gel -git enerjisi vb. gibi kaynaklar yenilenebilir ve bunları kullanmakla eksilmeyen enerji kaynaklarıdır. Yenilenebilir enerji kaynaklarının, temiz olması, hava kirliliğini, su kirliliğini ve sera etkisini azaltmaları, tükenmez olmaları vb. gibi birçok olumlu yönleri olmasına rağmen şu andaki kullanımları kısıtlıdır. Yenilenemeyen Enerji Kaynakları ise kömür, petrol, doğalgaz ve nükleer enerji gibi kaynaklar olup zamanla tükenmektedir. Yenilenemeyen enerji kaynaklarının çevreye birçok olumsuz etkileri de mevcuttur. Bu enerji kaynaklarından nükleer enerji, fisyon (çekirdek bölünmesi) veya

füzyon (çekirdek birleşmesi) sonucu açığa çıkan enerjidir. Ancak, füzyon, yıllar süren çabalara rağmen pratikte ümit vaat eden bir noktaya getirilememiştir. Nükleer enerji, sağlık sektöründe tanı ve tedavi amacıyla; sanayide, tarım ve hayvancılıkta önemli pek çok izotopun üretimi için; kalp pillerinden, uyduların ve uzay araçlarının enerji üreteçlerine kadar geniş bir yelpazede kullanılır(Zabunoğlu 2012). Dünyanın birçok yerinde değişik amaçlar için çok sayıda reaktörler yapılmıştır. Nükleer reaktörler, denizaltılarda, uçak gemilerinde, araştırma gemilerinde özellikle tercih edilir. Nükleer reaktör, bir nükleer reaksiyonun (fisyon) kontrollü bir şekilde gerçekleştirilmesini ve bu sırada açığa çıkan ısının sürekli ve düzenli olarak üretimini; güvenli, çevreci ve güvenilir bir şekilde sağlamak üzere tasarlanmış bir makinedir. Ancak, nükleer reaktörlerde doğal afetler ya da insan kaynaklı hatalar yüzünden tehlikeli durumlar ortaya çıkabilmektedir(TEGR, 2012). Nükleer reaktörün en önemli olumsuz yönü radyoaktivite yüzündendir. Radyoaktivite doğal bir olgudur ve her yerde vardır; ancak nükleer enerji üretimi sırasında reaktör kalbinde oluşan parçalanma (fisyon) ürünlerinin radyoaktivitesi çok yüksek düzeydedir. Normal çalışma koşullarında reaktör kalbinde tutulan bu radyoaktivite, bir kaza sırasında en önemli sorunu oluşturur(Ertürk vd. 2006).Genel olarak nükleer enerji konusunda yapılan çalışmalar incelendiğinde (Ateş, 2013; Ateş ve Saraçoğlu, 2013; Karagöz, 2007; Özdemir ve Çobanoğlu, 2008); nükleer enerji ile ilgili çalışma sonuçları farklılık göstermektedir. Buradan yola çıkarak genel olarak toplumun nükleer enerji konusunda bilgi eksikliklerinin ve yanlış bilgilere sahip oldukları söylenebilir. Nükleer enerji ve çevre ile ilgili toplumun genelini ilgilendiren konular her bireyin geleceğini yakından ilgilendirmekle birlikte, bu sorunların farkına varma ve bilinç kazanma daha çok ortaöğretim ve yükseköğretim döneminde mümkün olmaktadır. Bütün öğrencilerin üniversite eğitimini sürdürüp sürdüremeyeceği düşünüldüğünde farkındalığı yüksek öğrencilerin yetiştirilmesi orta öğretim seviyesinde daha da önem kazanmaktadır. Bu yüzden toplumun bilinçlendirilmesinde lise öğrencilerinin bilinçlendirilmesi ve bilgi düzeylerinin belirlenmesi önemlidir. Bu nedenle, çalışmamızda lise öğrencilerinin nükleer enerji hakkındaki bilgi düzeyleri ve bilgi düzeylerinin bazı değişkenler açısından farklılık gösterip göstermediğinin belirlenmesi amaçlanmıştır. Bu temel amaç doğrultusunda aşağıdaki sorulara yanıt aranmıştır.

4. Lise öğrencilerinin, nükleer enerji hakkındaki bilgi düzeyleri nedir?
5. Lise öğrencilerinin, nükleer enerji hakkındaki bilgi düzeyleri cinsiyete göre farklılaşmakta mıdır?
6. Lise öğrencilerinin, nükleer enerji hakkındaki bilgi düzeyleri lise türüne göre farklılaşmakta mıdır?
7. Lise öğrencilerinin, nükleer enerji hakkındaki bilgi düzeyleri sınıf değişkenine göre farklılaşmakta mıdır?

YÖNTEM

Araştırma Modeli

Lise öğrencilerinin nükleer enerji hakkında bilgi düzeylerini belirlemeyi amaçlayan bu çalışmada, amaca uygun olarak nicel araştırma yöntemlerinden betimsel tarama modeli kullanılmıştır. Bilindiği üzere tarama modelleri, geçmişte ya da halen var olan bir durumu var olduğu şekliyle betimlemeyi amaçlayan araştırma yaklaşımlarıdır ve araştırmaya konu olan olay, birey ya da nesne, kendi koşulları içinde ve olduğu gibi tanımlanmaya çalışılır(Karasar, 2009). Araştırmaya katılan lise öğrenci sayısı 409'dur. Ölçme aracı (Karagöz, 2007) tarafından geliştirilen anket soruları üzerinde düzenlemeler yapılarak uzman görüşleri alınarak veri toplama aracı oluşturulmuştur. Veri toplama aracının Crombach alpha değeri 0.80 olarak bulunmuştur.

Evren Örneklem

Araştırmanın evrenini 2010-2011 eğitim-öğretim yılı Eskişehir il merkezinde üç farklı lisede öğrenim gören 409 lise öğrencisi oluşturmaktadır. Araştırmaya katılan öğrencilerin 121'ü (%29,6) kadın iken 288'i ise (%70,4) erkektir. Araştırmaya katılan lise öğrenciler hakkında genel bilgiler Tablo 1'de ayrıntılı olarak verilmiştir.

Tablo 1. Araştırmaya Katılan Öğrencilerin Genel Özellikleri

Bireysel Özellikler		f	%
Cinsiyet	Kadın	121	29,6
	Erkek	288	70,4
Sınıf Düzeyi	9. Sınıf	173	42,3
	10. Sınıf	140	34,2
	11. Sınıf	46	11,2
	12. Sınıf	50	12,2
Lise Türü	Genel lise	55	13,4
	Fen lisesi	209	51,1
	Meslek lisesi	145	35,5
Toplam		409	100

Araştırmaya katılan öğrencilerin yarısından fazlasını fen lisesi öğrencileri (%51,1) oluşturmaktadır. Daha sonra sırasıyla meslek lisesi (%35,5) ve genel lise (%13,4) öğrencileri gelmektedir.

Tablo 2. Araştırmaya Katılan Lise Öğrencilerinin Nükleer Enerji Hakkındaki Bilgi Düzeylerine Ait Tanımlayıcı İstatistikler

Madde	\bar{X}
1 Nükleer teknolojiyle ilgiliyim.	2,7677
2 Kömür nükleer santrallerde yakıt olarak kullanılır.	3,5966
3 Doğalgaz nükleer santrallerde yakıt olarak kullanılır.	3,4230
4 Fuel oil nükleer santrallerde yakıt olarak kullanılır.	3,4328
5 Uranyum nükleer santrallerde yakıt olarak kullanılır.	3,7873
6 Radyoaktif atıklar denize bırakılır.	3,5819
7 Radyoaktif atıklar çeşitli işlemlerden geçirilip depolanır.	3,3447
8 Radyoaktif atıklar yakılarak gömülür.	3,5819
9 Radyoaktif atıklar çöpe atılır.	3,9022
10 Radyasyon çevreye zarar vermeyecek şekilde kontrol altına alınabilir.	3,5159
11 Radyasyon nükleer santrallerin diğer adıdır.	3,5648
12 Radyasyon enerjinin bir noktadan diğerine parçacıklar veya elektromanyetik dalgalar şeklinde aktarılmasıdır.	3,6479
13 Radyasyon madencilikte kullanılan ölçü birimidir.	3,9951
14 Radyasyon bir kanser türüdür.	3,7531
15 Nükleer teknolojinin kullanımı ülkelerin kendi inisiyatifinde değildir, denetleme ve takip uluslar arası bir kurum olan IAEA (Uluslar Arası Atom Enerji Ajansı) tarafından yapılır.	3,2983
16 Sağlık Bakanlığı Türkiye’de nükleer güvenlik ve radyasyon güvenliğinden sorumlu kurum/kuruluştur.	3,3545
17 Türkiye Atom Enerji Kurumu Türkiye’de nükleer güvenlik ve radyasyon güvenliğinden sorumlu kurum/kuruluştur.	3,4156
18 Çevre Bakanlığı Türkiye’de nükleer güvenlik ve radyasyon güvenliğinden sorumlu kurum/kuruluştur.	3,1980
19 Enerji Bakanlığı Türkiye’de nükleer güvenlik ve radyasyon güvenliğinden sorumlu kurum/kuruluştur.	3,4377
20 Çernobil nükleer santral kazasından sonra biri ABD’de diğeri Japonya’da olmak üzere iki kaza daha olmuştur.	3,0440
21 Bir ülkenin enerji programı, o ülkenin gelişmişlik düzeyiyle ilgilidir.	3,8337
22 Nükleer teknoloji konusunda halkımızın bilinç düzeyi yeterlidir.	3,7824
23 Nükleer teknolojinin ülkemiz için gerekliliğini halkımıza anlatmak için yapılacak bir çalışmada görev almak isterim.	2,9707
24 Nükleer teknolojinin en önemli uygulama alanı enerji konusunda da bir an önce üretime geçilmelidir.	3,3961
25 Enerji sorununun aşılmasında sadece bir teknoloji üzerinde durulmamalı, alternatif enerji üretim yolları geliştirilmelidir.	3,8998
26 Bir ülkenin alternatif enerji üretim yolları konusunda etkili çalışmalar yapabilmesi ancak nükleer teknolojiye sahip olmasıyla mümkündür.	3,0318
27 Enerji konusundaki sorunlarını çözememiş bir ülke ekonomik ve teknolojik konularda dışa bağımlı yaşamak zorundadır.	3,9267
28 Nükleer enerji ülkemizin enerji ihtiyacının giderilmesinde ideal bir çözüm yoludur.	3,3570
29 Nükleer teknolojiyi geliştirmek için yapılan çalışmalarda en fazla üzerinde durulan konu güvenlik konusudur. Böylece nükleer enerji günümüzde oldukça güvenli enerji üretim yollarından biri olmuştur.	2,7848
30 Nükleer teknolojinin beraberinde getirdiği risklerin yanında avantajları göz ardı edilemez.	3,7042

Tablo 2’de görüldüğü gibi lise öğrencilerinin nükleer enerji hakkındaki bilgi düzeylerini belirlemeyi amaçlayan 30 maddenin 3 ’üne ortalama olarak üç puan altında, kalan 27 maddeye de üç ile dört arasında puan verilmiştir. Bu maddelerden en yüksek puan verilen maddeler 13. ve 27. maddeler iken, en düşük puanlama yapılan maddeler 1. ve 29. maddelerdir. Bu sonuçlara göre lise öğrencilerin söz konusu nükleer enerji hakkındaki bilgi düzeylerinin, genel olarak ortalamanın üstünde olduğu söylenebilir.

Tablo 3. Lise Öğrencilerinin Nükleer Enerji Hakkındaki Bilgi Düzeylerinin Cinsiyete Göre Mann-Whitney U Testi Sonuçları

Madde	Kadın		Erkek		U (10 ⁴)	Z	p
	Sıra ortalaması	Sıra toplamı	Sıra ortalaması	Sıra toplamı			
5	187,33	22667,50	212,42	61177,50	1,529	-0,099	0,041
7	227,19	27490,50	195,68	56354,50	1,474	-2,527	0,012
11	185,79	22480,50	213,07	61364,50	1,510	-2,196	0,028
22	223,50	27044,00	197,23	56801,00	1,518	-2,139	0,032
23	185,15	22403,50	213,34	61441,50	1,502	-2,256	0,024
24	176,82	21395,00	216,84	6245,00	1,401	-3,234	0,001
25	224,20	27128,00	196,93	56717,00	1,510	-2,234	0,025
27	221,92	26852,00	197,89	56993,00	1,538	-1,972	0,049
30	187,58	22697,00	212,32	61148,00	1,532	-2,008	0,045

Tablo 3’den görüldüğü üzere 5, 7, 11, 22, 23, 24, 25, 27 ve 30. maddelere verilen puan ortalamaları bakımından erkek ve kadın öğrenciler arasındaki farklılıklar istatistiksel olarak anlamlı bulunmuştur. Anlamlı fark bulunan

söz konusu dokuz maddeden beş tanesi (5, 11, 23, 24, 30) erkek öğrenciler lehine iken, geri kalan dört madde (7, 22, 25, 27) kadın öğrenciler lehinedir.

Tablo 4. Araştırmaya Katılan Lise Öğrencilerin Nükleer Enerji Hakkındaki Bilgi Düzeylerinin Lise Türü Değişkenine Göre Farklılaşma Durumu (Kruskal-Wallis Testi)

Madde	Fen Lisesi	Genel Lise	Meslek Lisesi	df	X ²	p	Anl.Fark
	Sıra ortalamaları						
1	223,89	184,04	185,73	2	11,497	0,003	ML-FL*
2	240,13	146,40	176,59	2	43,016	0,000	GL-FL*; ML-FL*
3	246,58	144,81	167,90	2	57,583	0,000	ML-FL*; GL-FL*
4	251,66	134,29	164,57	2	74,275	0,000	GL-FL*; ML-FL*
5	258,34	121,30	159,87	2	99,136	0,000	GL-FL*; ML-FL*
6	233,61	158,20	181,51	2	28,599	0,000	GL-FL*; ML-FL*
7	238,74	175,23	167,66	2	36,874	0,000	ML-FL*; GL-FL*
8	240,95	175,66	164,30	2	42,792	0,000	ML-FL*; GL-FL*
9	252,04	151,59	157,46	2	76,961	0,000	ML-FL*; GL-FL*
10	222,28	185,67	187,42	2	9,906	0,007	ML-FL*
11	242,60	135,82	177,05	2	51,109	0,000	GL-FL*; ML-FL*
12	249,91	176,15	151,20	2	69,744	0,000	GL-FL*; ML-FL*
13	236,47	167,23	173,97	2	35,233	0,000	GL-FL*; ML-FL*
14	258,32	132,19	155,77	2	98,095	0,000	GL-FL*; ML-FL*
15	218,01	182,29	194,87	2	6,057	0,048
16	237,63	166,34	172,63	2	35,625	0,000	GL-FL*; ML-FL*
17	230,82	173,16	179,86	2	22,891	0,000	GL-FL*; ML-FL*
18	234,41	158,05	180,42	2	30,135	0,000	GL-FL*; ML-FL*
19	225,66	192,09	180,12	2	15,037	0,001	ML-FL*
20	215,17	165,56	205,30	2	8,803	0,012	GL-FL*
21	246,48	177,07	155,81	2	58,907	0,000	ML-FL*; GL-FL*
22	240,14	183,55	162,49	2	42,399	0,000	ML-FL*; GL-FL*
24	222,62	156,15	198,13	2	15,557	0,000	GL-FL*
25	258,24	157,56	146,26	2	95,841	0,000	ML-FL*; GL-FL*
26	187,82	232,02	219,51	2	10,120	0,006	FL-ML*; FL-GL*
27	249,18	165,55	156,28	2	66,267	0,000	ML-FL*; GL-FL*
29	219,69	186,15	190,97	2	7,041	0,030
30	227,83	184,25	179,96	2	17,278	0,000	ML-FL*; GL-FL*

Tablo 4’te lise öğrencilerin nükleer enerji hakkındaki bilgi düzeylerinin lise türü değişkenine göre farklılaşma durumu incelenmiştir. Ankette yer alan 23 ve 28. maddeler hariç 28 maddenin farklılaştığı görülmektedir. Maddeler incelendiğinde 26. madde haricinde tüm maddelerde fen lisesinde okuyan lise öğrencilerinin lehine olduğu görülmektedir. Maddelerin çoğunun fen lisesinde okuyan lise öğrencilerinin lehine olması, fen liselerindeki eğitim, öğretim ve öğrenci kalitesine bağlanabilir. 26. maddede ise meslek lisesinde ve genel lisede okuyan öğrencilerin lehine olduğu görülmektedir.

Tablo 5. Araştırmaya Katılan Lise Öğrencilerin Nükleer Enerji Hakkındaki Bilgi Düzeylerinin Sınıf Değişkenine Göre Farklılaşma Durumu (Kruskal-Wallis Testi)

Madde	9.sınıf	10.sınıf	11.sınıf	12.sınıf	df	X ²	p	Anl.Fark
	Sıra ortalamaları							
2	179,24	214,33	262,33	215,28	3	21,627	0,000	9*-10; 9-11*
3	177,20	208,86	279,21	222,11	3	30,587	0,000	9-11*; 10-11*
4	173,95	210,25	290,87	218,73	3	39,886	0,000	9-10*; 9-11*; 10-11*; 12-11*
5	178,72	212,12	261,79	223,75	3	22,742	0,000	9-11*
6	202,71	209,23	241,77	167,25	3	10,534	0,015	12-11*
7	199,47	198,40	253,74	197,77	3	9,298	0,026	10-11*; 9-11*
8	165,48	227,28	256,73	231,78	3	38,260	0,000	9-10*; 9-12*; 9-11*
9	186,47	207,75	265,50	205,75	3	18,596	0,000	9-11*; 10-11*
11	182,49	216,96	255,42	203,01	3	17,106	0,001	9-10*; 9-11*
12	185,39	206,68	266,89	211,22	3	19,270	0,000	9-11*; 10-11*
13	177,29	230,94	249,40	187,37	3	27,618	0,000	9-10*; 9-11*; 10-11*
14	173,98	214,91	275,14	220,03	3	33,127	0,000	9-10*; 9-11*; 10-11*
16	190,58	207,26	242,00	214,51	3	8,125	0,044	9-11*
18	182,24	221,90	258,62	187,09	3	21,496	0,000	9-10*; 9-11*; 12-11*

21	188,93	212,24	248,15	200,63	3	10,841	0,013	9-11*
25	178,65	212,64	241,67	241,06	3	20,104	0,000	9-10*; 9-12*; 9-11*
27	191,83	199,19	251,21	224,32	3	11,994	0,007	9-11*; 10-11*

Tablo 5'te lise öğrencilerin nükleer enerji hakkındaki bilgi düzeylerinin sınıf değişkenine göre farklılaşma durumu incelenmiştir. Ankette 17 maddenin (2, 3, 4, 5, 6, 7, 8, 9, 11, 12, 13, 14, 16, 18, 21, 25, 27) farklılaştığı görülmektedir. Maddelerdeki anlamlı fark incelendiğinde lise öğrencilerin nükleer enerji hakkındaki bilgi düzeylerinin sınıf değişkenine göre genellikle üst sınıflar lehine olduğu görülmektedir.

SONUÇ

Lise öğrencilerin nükleer enerji hakkındaki bilgi düzeylerinin bazı değişkenler açısından farklılık gösterip göstermediğinin belirlenmesi amaçlanan araştırmanın bulguları genel olarak değerlendirildiğinde aşağıdaki sonuçlar elde edilmiştir:

- Lise öğrencilerin söz konusu nükleer enerji hakkındaki bilgi düzeylerinin, genel olarak ortalamann üstünde olduğu söylenebilir.
- Lise Öğrencilerinin nükleer enerji hakkındaki bilgi düzeylerinin cinsiyete göre 5, 7, 11, 22, 23, 24, 25, 27 ve 30. maddelere verilen puan ortalamaları bakımından erkek ve kadın öğrenciler arasındaki farklılıklar istatistiksel olarak anlamlı bulunmuştur.
- Lise Öğrencilerin Nükleer Enerji Hakkındaki Bilgi Düzeylerinin Lise Türü Değişkenine Göre anlamlı farklılıklar bulunmuştur. Maddelerin çoğunun fen lisesinde okuyan lise öğrencilerinin lehine olması, fen liselerindeki eğitim, öğretim ve öğrenci kalitesine bağlanabilir. Sadece 26. maddede ise meslek lisesinde ve genel lisede okuyan öğrencilerin lehine olduğu görülmektedir. Bunun nedenleri araştırılmalıdır.
- Lise öğrencilerin nükleer enerji hakkındaki bilgi düzeylerinin sınıf değişkenine göre 2, 3, 4, 5, 6, 7, 8, 9, 11, 12, 13, 14, 16, 18, 21, 25, 27 maddelere verilen puan ortalamaları bakımından anlamlı farklılıklar bulunmuştur. Maddelerdeki anlamlı fark incelendiğinde lise öğrencilerin nükleer enerji hakkındaki bilgi düzeylerinin sınıf değişkenine göre genellikle üst sınıflar lehine olduğu görülmektedir.

KAYNAKLAR

- Ateş, H. (2013) Fen Bilgisi Öğretmen Adaylarının Nükleer Enerji Hakkındaki Düşünceleri, Erciyes Üniversitesi, Eğitim Bilimleri Enstitüsü, Yüksek Lisans Tezi, Kayseri, 105s.
- Ateş, H., ve Saraçoğlu, M. (2013). Fen Bilgisi Öğretmen Adaylarının Gözünden Nükleer Enerji. Journal of Kirsehir Education Faculty, 14(3).
- Ertürk F., Akkoyunlu A., Varınca K. B., (2006). *Enerji üretimi ve çevresel etkileri* Türkasya Stratejik Araştırmalar Merkezi stratejik rapor no: 14, Tasam Yayınları, İstanbul.
- Karagöz, C. (2007). Kimya öğretmen adaylarının nükleer enerjiye karşı ilgi ve tutumları, Gazi Üniversitesi, Eğitim Bilimleri Enstitüsü, Yüksek Lisans Tezi, Ankara, 97s.
- Karasar N., (2009). *Bilimsel Araştırma Yöntemi*, 20. Baskı, Nobel Yayın Dağıtım, Ankara.
- Özdemir, Ç., Çobanoğlu, E. O. (2008). Türkiyede Nükleer Santrallerin Kurulması ve Nükleer Enerji Kullanumu Konusundaki Öğretmen Adaylarının Tutumları, *Hacettepe Üniversitesi Eğitim Fakültesi Dergisi*, 34, 218-232
- Türkiye'nin Enerji Görünümü Raporu(TEGR), (2012). TMMOB Makine Mühendisleri Odası, Genişletilmiş İkinci Baskı, Yayın No: MMO/588, ISBN: 978-605-01-0358-8, Ankara
- Uyar T.S., (2001). *Enerji Sorunu Nedir? Alternatif Enerji Çözüm müdür?* NEU-CEE 2001 Electrical, Electronic and Computer Engineering Symposium, 23-26, Lefkoşa TRNC.
- Zabunoğlu H.O., (2012). *Nükleer Enerji: Nedir? Nasıl üretilir? İlgili meseleler*, Hacettepe Üniversitesi, Nükleer Enerji Mühendisliği, Ankara.

CEBİR ÖĞRETİMİNDE ÇOKLU TEMSİL TEMELLİ ÖĞRETİMİN YERİ VE ÖNEMİ

THE ROLE AND IMPORTANCE OF MULTIPLE REPRESENTATION BASED INSTRUCTION IN ALGEBRA TEACHING

Deniz KAYA
Dokuz Eylül Üniversitesi, Eğitim Bilimler Enstitüsü
denizkaya50@yahoo.com

Doç. Dr. Cenk KEŞAN
Dokuz Eylül Üniversitesi, Buca Eğitim Fakültesi
cenk.kesan@deu.edu.tr

ÖZET: Öğrencilerin cebiri anlamlı öğrenmeleri; farklı ortamlara bilgiyi transfer edebilmeleri, kavramlar arası ilişkileri oluşturabilmeleri, cebirsel düşünebilme ve muhakeme edebilmeleri, öğrenme alanları arasında etkileşim kurabilmeleri, çeşitli durumlardaki değişimi analiz edebilmeleri ve edindikleri kazanımları çeşitli temsil biçimlerine dönüştürebilmeleriyle yakından ilgilidir. Bu çalışmada, ilköğretim seviyesindeki öğrenciler için cebir öğretiminde çoklu temsil temelli öğretimin yeri ve önemi tartışılarak, yapılan çalışmalar ışığında bu durumun gerekçesi ortaya konulmaya çalışılmıştır.

Anahtar sözcükler: cebir, cebir öğretimi, çoklu temsil temelli öğretim.

ABSTRACT: Meaningful learning of algebra is closely associated to that students can transfer the information to different environments, create relationships between concepts, use algebraic thinking and reasoning, form an interaction between learning domains, analyze changes in the various situations and change the acquired gains into the various representations. In this study, the role and importance of the multiple representation based instruction in algebra teaching for primary school students were discussed and the reason of this situation was tried to reveal in the lights of studies.

Key words: algebraic, algebraic teaching, multiple representation based instruction

GİRİŞ

Cebir, örüntülerin, kuralların ve sembollerin bir dilidir (O'Bannon, Reed ve Jones, 2002'den akt. Dede ve Peker, 2007:36). O halde cebir, dünyanın daha iyi algılanabilmesi için bir araçtır. Bu sayede cebir, nicel ilişkilerin analizinde, problemlerin çözümünde, modelleme durumlarında, temsiller için gerekli araçları ve dili sağlama ile genellemeleri belirtme gibi daha birçok matematiksel çabaların temel omurgası olarak hizmet verir. Bundan dolayı yarının işgücü temsilcileri olarak tüm öğrenciler, cebirin önemini ve yararını bilmeleri ve anlamlı olarak kabul etmeleri gerekir (Romberg ve Spence, 1995). Matematik ve öğretimi düşünüldüğünde cebirin özel bir yeri vardır. Çünkü cebir öğrencilerin matematiği anlamasında, matematiksel düşünmesinde ve matematik okuryazarı olmalarında oldukça önemlidir. Cebir okul matematiğinde önemli bir konu olmasa da okul matematiğini bütünleştirme de önemli bir anahtar kavramdır (NCTM, 2000). Stacey ve MacGrigor (1997)'e göre, cebir öğrencilere soyut düşünmenin ve mantıksal çıkarım yapmanın kapılarını aralar. Lacampagne (1995), "cebir, matematiğin dilidir. O, tam manasıyla öğrenilmesi durumunda, ileri matematiksel konular için kapılar açar. O, öğrenilememesi durumunda üniversite ve teknolojiye dayalı kariyer kapılarını kapatır..." demiştir (akt. Dede ve Argün, 2003:180). Cebir, matematiğin geniş bir kültürünü içine alan küçük bir kültürü oluşturur. Öğrenciler, eski kültürden yani aritmetikten bu yeni kültüre yani cebire geçerken zorlanmaktadır. Kısaca kendisini bu yabancı kültürün (cebir) içerisinde bulan öğrenciler "kültürel şok" olarak adlandırılabilirler (Lee, 1996).

Cebir bilgileriyle ilgili olarak öğretme/öğrenme güçlüklerinin olduğu yüzlerce yıl öncesinde fark edilmeye başlanmış fakat sorunların ne olduğu anlaşılabilmiştir. Bu bağlamda, günümüzde bile çok sayıda öğrenci temel cebir bilgilerini ve becerilerini edinerek gerekli yeterlikleri edinmemektedir (Ersoy ve Erbaş, 2005:20). Ülkemiz Millî Eğitim Bakanlığı bünyesinde yer alan Eğitimi Araştırma ve Geliştirme Daire Başkanlığı [EARGED] 1996 yılında, içinde cebir müfredatında bulunduğu bir rapor hazırlamıştır. Hazırlanan raporda öğrencilerden bazılarının birinci derecen cebirsel sözel ifadeleri içeren problemleri aritmetik işlemler kullanarak

çözebildiklerini ancak birinci dereceden denklemlerin çözümlerini bulamadıkları ve cebirsel ifadeleri anlamakta belirli zorluklara sahip oldukları ifade edilmiştir.

Cebir öğretimi ve öğrenimi ilköğretimde başlayarak ortaokul da denklemler, lise de ise fonksiyon bilgilerine kadar geniş bir alanı içine alan yelpazeye yayılır. Bu durum okul öncesi dönemden 12. sınıfa kadar eğitim programında tüm öğrencilere sağlanması gereken cebir alt öğrenme alanlarına yönelik konuları kapsayan cebir standartları süreçlerinden oluşmaktadır. Bu süreç NCTM (2000:223)'e göre *-örüntü, bağıntı ve fonksiyonları anlama, cebirsel sembolleri kullanarak matematiksel durum ve yapıları çözümlenme ve sunma, matematiksel modelleri nicel ilişkileri anlamak ve sunmak için kullanmak, çeşitli durumlarda değişimi analiz etme-* olarak kategorilere ayrılmıştır. Bu kategorilerde yer alan 6-7 ve 8. sınıflara ait konuların alt öğrenme alanları ise şu şekildedir:

- Çeşitli şekilleri grafik, tablo, kelime ve mümkünse sembolik kurallarla açıklama, çözümlenme ve genelleme yapmak.
- Bağıntıların farklı gösterim biçimlerini karşılaştırma ve ilişkilendirme yapma.
- Doğrusal ya da doğrusal olmayan fonksiyonları belirleme ve tablo, grafik ya da denklem kullanarak karşılaştırma yapmak.
- Değişkenlerin farklı kullanımlarını anlamak için ilk kavramsal anlamayı geliştirmek.
- Doğru grafikleri ile sembolik ifadelerin kesişim ve eğimlerine dikkat ederek aralarındaki ilişkiyi keşfetmek.
- Doğrusal ilişkileri içeren problemler çözmeye ve ifade etmek için sembolik cebir kullanmak.
- Doğrusal denklemleri çözmek ve cebirsel olarak ifade etmek için eşdeğer formüller oluşturmak ve belirlemek.
- Grafikleri, tabloları veya denklemleri kullanarak içeriği verilen problemleri modellemek ve çözmek.
- Doğrusal ilişkilerde sayısal değişimleri analiz etmek için grafikleri kullanmak (NCTM, 2000:223).

Cebir, matematik dersi içerisinde önemli bir yere sahip konu alanlarından biridir ve özellikle son 25 yıl içerisinde cebirin öğretilmesine/öğrenimine/anlamına ve gelişen teknolojinin cebir öğretiminin etkisine yönelik birçok araştırma/çalışma faaliyetleri yürütülmüş, hala da yürütülmektedir. Yapılan bu çalışmalar sonucunda birçok ülke cebir öğretimi konusunda öğretim programlarında köklü değişikliklere ve düzenlemelere gitmiştir. Ancak yapılan değişikliklere ve düzenlemelere rağmen birçok ülkede öğrencilerin cebiri öğrenmede hala sıkıntı yaşadıkları görülmektedir (Baki, 1998; Dede ve Argün, 2003; Kieran, 1992). Bu durumu Cockcroft (1982:60) şu şekilde özetlemiştir: Cebir, öğrenciler arasında olumsuz tutumların ve önemli bir kafa karışıklığının nedenidir. Her ne kadar cebiri öğrenme/öğretme konusunda çok sayıda çalışmalar/araştırmalar yapılmış olsada, özellikle öğretmenlerin cebiri nasıl öğretebilecekleri ile etkili cebir öğrenme ortamlarının sahip olması gereken unsurların (gelişmelerin) neler olabileceğine yönelik çalışmalar çok az sayıdadır. Bu durumun okullarda cebir öğretiminin geleneksel yöntemlere bağlı kalınarak sürdürülmesine neden olduğu düşünülmektedir (Doerr, 2004). Dede, Yalın ve Argün (2002)'e göre öğrencilerin cebir öğretiminde zorlanmalarının nedenleri; değişkenlerin farklı kullanımlarını ve genelleme yapmadaki rollerini bilememe ile değişkenleri yorumlayamama ve işlem yapamama olarak belirtmektedir. Bu durum Thomas ve Tall (2001)'e göre ise öğrencilerin, cebir aşamasındaki manipülasyon işlemlerinde zayıf olmaları ve başaramamaları ile ilgili bir durumdur.

YÖNTEM

Problem Durumu

Yaşadığımız çağa olan katkısı hem geçmişi hem de geleceği inşa etmedeki rolleri düşünüldüğünde matematiği anlamak, onun dilini iyi bilmekten geçer. Çünkü sahip olduğu semboller, tablolar, grafikler, çizgiler, sütunlar ve rakamlar matematiği ortak bir alan haline getirmektedir. Bu sayede tüm insanlık bu eşsiz hazineden faydalanmakta, ortak duygu ve düşünceler etrafında aynı dili rahatlıkla konuşabilmektedir. Aynı dili konuşabilmenin verdiği ilhamla matematikte birçok yenilikçi anlayış ortaya atılmakta ve matematiği öğrenmedeki zorlukların üstesinden gelebilecek yenilikçi öğrenme yaklaşımlarına ağırlık verilmektedir. Varlığı çok eskilere dayanmasına rağmen öğrenme ortamlarındaki kullanımı sürekli olarak ihmal edilen çoklu temsil temelli öğretim uygulamaları da bu yaklaşımlardan bir tanesidir. Matematiksel kavramların öğrenciler tarafından kavramsal olarak anlaşılabilmesi için araştırmacıların önerdiği en etkili yöntemlerden biri, öğretimde çoklu temsillerin kullanılmasıdır (Sevimli, 2009:9). Nitekim dünyanın her yerinde evrensel bir değere sahip matematiksel dilin çoklu gösterimleri hem öğrenmeyi anlamlı hale getirmesi hem de yeni öğrenmelere kolaylık sağlaması açısından değerlidir (NCTM, 2000; 2008). Çoklu temsil yaklaşımı matematik öğretimi ve öğrenimini etkileyen önemli bir faktördür. Bu yaklaşım, matematiksel ilişki, kavram veya kuralın sözlü, grafiksel, tablo ya da cebirsel sembol olarak sunulması diye düşünülebilir (Durmuş ve Yaman, 2002).

Bu çalışmada, ilköğretim seviyesindeki öğrenciler için cebir öğretiminde çoklu temsil temelli öğretimin yeri ve önemi tartışılarak, yapılan çalışmalar ışığında bu durumun gereğesi ortaya konulmaya çalışılmıştır.

Çoklu Temsil Temelli Öğretim

Çoklu temsilleri kullanmanın önemi öğrencilerin matematik eğitimi boyunca vurgulanmalıdır. Özellikle günümüzde teknolojik araçlar artık öğrencilerin çoklu temsilleri kullanabilmelerine yönelik daha fazla ve farklı deneyimler yaşamalarına fırsat tanımaktadır. Bugün birçok yazılım paketi öğrencilere bir işlevi eş zamanlı olarak tablo, grafik ve denklem şeklinde görüntülemelerine imkan sağlamaktadır (NCTM, 2000:69). Schultz ve Waters (2000)'e göre çoklu temsil yaklaşımı kavramsal anlamayı geliştirdiği gibi öğrencileri daha yüksek seviyede matematik yapmak için hazırlar. Gerçek dünya matematiğine başvurur. Etkili olarak daha fazla teknoloji kullanımını sağlar ve öğrencileri farklı öğrenme stillerine adapte eder.

Çoklu temsil temelli öğretime ve çoklu temsillerin matematik öğretimi üzerindeki etkilerine geçmeden önce “temsil” kavramını açıklamaya çalışalım. Türk Dil Kurumu (2013) temsili; “birinin veya bir topluluğunun adına davranmak” şeklinde tanımlamıştır. Matematikte ise temsil kavramı matematiğin dilini oluşturmaktadır. Birçok alanda olduğu gibi matematik dilinin de gösterim biçimleri ve karşılıkları mevcuttur. Bu biçimlere, matematik eğitim bilimcileri “temsil” veya “gösterim” demektedir (Özgün-Koca, 1998). Kaput (1987)'e göre temsil, soyut kavram ve sembollerle; gerçek dünya içindeki somut nesnelere dönüşecek şekilde modelleme işlemi yapma ya da nesnelere ve matematiksel semboller arasındaki ilişkidir. Confrey ve Smith (1991) ise temsilleri; denklemler, tablolar ve grafikler gibi matematiksel fikirleri temsil eden araçlar olarak yorumlamıştır. Temsil kavramının hem anlaşılabilirliğini artırmak hem de varlığına işaret etmek için gelişi güzel değil de etkili bir biçimde sunulması gerekir. Temsillerin etkinliğini artırmak için ise (i) temsilin bilişsel ve anlamsal özelliği, (ii) üzerinde çalışılan etkinliğin gerektirdikleri, (iii) içeriğin yapısı (önceki bilgiler ve bilişsel yapılar) olmak üzere üç önemli noktaya dikkat edilmelidir (Cox, 1999:343). Alanyazı incelendiğinde temsillerin içsel temsil ve dışsal temsil olmak üzere iki kısma ayrıldığı görülmektedir. Alanyazı doğrultusunda içsel ve dışsal temsillerle ilgili yapılan tanımlamalar ise şu şekildedir:

İçsel Temsiller: İçsel semboller, sözel-sözdizimsel, imgesel (hayal gücüne dayanan) biçimsel ve duygusal simgeler olmak üzere çeşitli formlardan oluşmaktadır ve içsel temsilleri doğrudan gözlemek mümkün değildir. Öğrencilerin problem çözme ve matematiksel süreç becerilerine yönelik birey davranışlarının ortaya koymuş olduğu bilişsel konfigürasyonlar içsel temsilleri oluşturur (Goldin ve Janvier, 1998). Goldin (1998b) içsel temsilleri, (1) sözel, (2) imgesel, (3) biçimsel notasyonal, (4) planlama, izleme, uygulama ve kontrol, (5) duygusal temsil sistemleri olmak üzere beş kategori altında toplamıştır.

Dışsal temsiller: Öğrencilerin kişisel sembolleri, doğal dilleri, görsel imgeleri ve uzamsal temsilleri ile matematiksel semboller, yapılar, işaretler, karakterler ve imgeler dışsal temsilleri oluşturur (Goldin ve Shteingold, 2001; Goldin ve Janvier, 1998). Janvier, Bednarz ve Belanger (1987:) dışsal temsillerin sembol, şema, diyagram, işaretler gibi düzenlemelere karşılık geldiğini belirtmiştir. Bu durum ise Cai (2005)'e göre, görünen nesnelere ya da kayıtlara karşılık gelen bireyin gerçekle ilgili görüşünden oluşmaktadır.

Çoklu temsilleri içsel ve dışsal temsiller olarak sınıflandıran araştırmacıların yanında çoklu temsil kavramını farklı bakış açısı ile sınıflandıran veya modelleyen araştırmacılara da rastlamak mümkündür. Örneğin, Lesh, Post ve Behr (1987) tarafından yapılan sınıflandırmada temsiller; durağan resimler, somut nesnelere, yazılı semboller, gerçek hayat durumları ve konuşma dilinden oluşmaktadır (akt. Kılıç, 2009). Kaput (1987) temsillere yönelik modelini “*temsil eden ve edilen dünya*”, “*temsil eden ve edilen dünyanın görüşleri*” ve “*iki dünya arasındaki ilişki*” olarak açıklamaktadır.

Cebir Öğretiminde Çoklu Temsil Temelli Öğretim

Öğrencilerin cebiri anlamlı öğrenmeleri; farklı ortamlara bilgiyi transfer edebilmeleri, kavramlar arası ilişkileri oluşturabilmeleri, cebirsel düşünme ve muhakeme edebilmeleri, öğrenme alanları arasında etkileşim kurabilmeleri, çeşitli durumlardaki değişimi analiz edebilmeleri ve edindikleri kazanımları çeşitli temsil biçimlerine dönüştürebilmeleriyle yakından ilgilidir. Cebir öğrenme sürecinde öğretim materyallerinin ve somut nesnelere kullanılması, bilgisayar destekli öğrenme ortamlarının oluşturulması ve çoklu temsillerden yararlanılmasının öğrencilerin cebir kavramlarını anlama, birbiriyle ilişkilendirebilme ve yapılandırma süreçlerine olumlu yönde katkı sağlamaktadır (Çıkla, 2004:166). Öğrencilere cebir kavramının öğretilmesinde çoklu temsillerden yararlanmak, kavramlar arası ilişkilerin inşasında, yapılandırılmasında ve anlaşılmasında pozitif yönde yararları bulunmaktadır. Özellikle matematiksel kavramların anlaşılmasını kolaylaştırması, esnek yapısı sayesinde matematiksel iletişimi kolaylaştırması, öğrencileri düşünmeye yöneltmesi ve bu düşünceleri yorumlamaya olanak sağlaması açısından çoklu temsiller, hem cebirsel düşünmenin hem de cebirsel muhakemenin gelişimine katkısı büyüktür (Çıkla, 2004; McGowan ve Tall, 2001; NCTM, 2000).

Cebir öğretimi sırasında karşılaşılan zorlukların temelinde öğrencilerin cebirsel işlemlerle baş başa kalması ve cebirin bilinmeyenler, eşitlikler ve denklemler şeklinde algılanması yatmaktadır. Lesh, Post ve Behr (1987)'e göre öğrenciler cebir konusunda okulda sınırlı bir bakış açısı kazanmakta ve öğrencilere cebir hakkında “düşünmek” yerine eşitliklerde işlem yapma ve yazma öğretilmektedir (akt. Sert, 2007:20). Oysaki cebir düşünebilmeyi, görebilmeyi, analiz edebilmeyi ve dönüşüm yapabilmeyi gerektirir. Tam bu noktada çoklu temsiller cebirin farklı yönlerini öğrencilere hissettirebilir ve cebirin sadece işlemsel düzeyden oluşmadığını göstererek temsiller arası geçişlere imkân tanıyabilir. Janvier, Bednarz ve Belanger (1987)'e göre matematiğin doğal bir parçası olan çoklu temsillerin matematik öğretiminde kullanılması problem çözme sürecinde bazı zorlukları azaltmaya yardımcı olabilir. Birçok araştırmacı gibi Schneider (1995) de cebirde çoklu temsillerin önemine vurgu yapmış ve temsilleri öğrencilere, matematiğe yönelik kavramları kelimelerde sözel, tablolarla sayısal, grafiklerde görsel ve sembollerde cebirsel olarak göstermeye yarayan bir araç olduğunu belirtmiştir.

Çoklu temsillerin cebir kavramlarının öğretilmesinde kullanılması birçok karmaşık yapıların değişik yönlerini ortaya çıkarmada, görsellik katarak somutlaştırmada, değişik bakış açıları kazandırmada ve öğrencileri öğrenmeye cesaretlendirmede büyük öneme sahip olduğu belirtilmektedir. Cebir öğretimin ve öğrenimin başından itibaren çeşitli temsillerin sunulması gerekir. Bu gösterimlerin cebirsel ilişkilere ait problemlerin çözümünde kullanılması öğrencilere hem derin hem de zengin anlamalar inşa etmelerine fırsat sağlar (Yerushalmy ve Schwartz, 1993:41). Günümüzde birçok yurt dışı indeksli kaynaklarda çoklu gösterimler ayrı bir konu başlığı altında ele alınmakta ve özellikle cebirsel kavramların öğretimi sırasında sıkça kullanılmasının öğrencilerin anlamlı öğrenmelerine hizmet edeceği belirtilmektedir (NCTM, 2000).

SONUÇLAR

Çoklu temsil temelli öğretimin etkinliğini artırmak için öğretmenin matematiksel bilginin çeşitli temsilleri hakkında bilgi sahibi olması gerekir. Örneğin, “Elimdeki 6 balondan 2 tanesi patladı. Kaç balonum kaldı?” ifadesi sözel temsili, gerçekten 6 balondan 2'sinin patlatılması olayı gerçek hayat durumu, balon yerine kullanılacak 6 nesneden 2 tanesinin ayrılarak modellenmesi somut nesnelere, çeşitli şekillerin ya da resimlerin kullanılması resimle temsil, $6-2=?$ eşitlik ya da denklemler de sembolle temsili ifade etmektedir (Olkun ve Toluk-Uçar, 2006:11). Örnekten de anlaşılacağı üzere matematiksel kavramların ve modellerin inşasında çoklu temsillere olan gereksinim kaçınılmazdır. Bundan dolayı çoklu temsillerin öğrenme ortamlarına aktarılmasında öğreticilere önemli görevler ve sorumluluklar düşmektedir. Sonuç olarak diyebiliriz ki; öğretmenler birden fazla çoklu temsilleri kullanmaya öğrencileri teşvik etmeli ve onlar tarafından taşınan temsillerin matematiksel anlayış düzeyini değerlendirmeli, çoklu temsilleri etkili bir şekilde kullanmalarına ve geliştirmelerine rehberlik etmelidir (NCTM, 2000:136). Sonuç olarak çoklu temsil kullanımının ve aralarındaki geçişlerin cebir öğrenimi üzerinde önemli etkileri bulunmaktadır. Çoklu temsil uygulamaları, öğrencilerin zihinsel aktivitelerini harekete geçirerek hem kavramsal hem de işlemsel anlamının gelişimine yardımcı olmaktadır. Dolayısıyla cebir öğrenme alanlarına ait kavramların öğrencilere etkin bir şekilde sunulmasında farklı temsil türlerinin kullanılması nitelikli bir eğitim anlayışının gelişimine faydaları vardır.

NOT: Bu çalışma, 2013.KB.EĞT.009 nolu proje kapsamında Dokuz Eylül Üniversitesi Bilimsel Araştırma Projeleri Koordinasyon Birimi tarafından desteklenen, ikinci yazar danışmanlığında, birinci yazar tarafından hazırlanan “Çoklu Temsil Temelli Öğretimin Öğrencilerin Cebirsel Muhakeme Becerilerine, Cebirsel Düşünme Düzeylerine ve Matematiğe Yönelik Tutumlarına Etkisi Üzerine Bir İnceleme” isimli doktora çalışmasının bir bölümünü oluşturmaktadır.

KAYNAKLAR

- Baki, A. (1998). Matematik öğretiminde işlemsel ve kavramsal bilginin dengelenmesi. Atatürk Üniversitesi 40. Kuruluş Yıldönümü Matematik Sempozyumu. (20-22 Mayıs 1998). Erzurum: Atatürk Üniversitesi.
- Cai, J. (2005). US and Chinese teachers' constructing, knowing and evaluating representations to teach mathematics. *Mathematical Thinking and Learning*, 7(2), 135-169.
- Confrey, J. & Smith, E. (1991). A framework for functions: prototypes, multiple representations and transformations. In R. G. Underhill (Ed.), *Proceedings of the 13th annual meeting of the north American chapter of the international group for the psychology of mathematics education* (pp. 57-63). Blacksburg: Virginia Polytechnic Institute and State University.
- Cox, R. (1999). Representation construction, externalised cognition and individual differences. *Learning and Instruction*, 9(1), 343-363.
- Çıkla-Akkuş, O. (2004). Çoklu temsil temelli öğretimin yedinci sınıf öğrencilerinin cebir performansına, matematiğe karşı tutumuna ve temsil tercihlerine etkisi. Yayınlanmamış doktora tezi, Orta Doğu Teknik Üniversitesi, Fen Bilimleri Enstitüsü.
- Dede, Y., Yalın, H. ve Argün, Z. (2002). İlköğretim 8. sınıf öğrencilerinin değişken kavramının öğrenimindeki hataları ve kavram yanılgıları. *UFBMEK* (16-18 Eylül 2002). Ankara: ODTÜ.

- Dede, Y. ve Argün, Z. (2003). Cebir, öğrencilere niçin zor gelmektedir?. *Hacettepe Üniversitesi Eğitim Fakültesi Dergisi*, 24, 180-185.
- Dede, Y. ve Peker, M. (2007). Öğrencilerin cebire yönelik hata ve yanlış anlamaları: matematik öğretmen adaylarının bunları tahmin becerileri ve çözüm önerileri. *İlköğretim Online Dergisi*, 6(1), 35-49.
- Doerr, H. M. (2004). Teachers' knowledge and the teaching of algebra. In K. Stacey & H. Chick (Ed). The future of the teaching and learning of algebra (pp. 267-290). Dordrecht, The Netherlands: Kluwer.
- Durmuş, S. ve Yaman, H. (2002). Mevcut teknolojilerin sunduğu çoklu temsil olanaklarının oluşturmacı yaklaşıma getireceği yenilikler. V. Ulusal Fen Bilimleri ve Matematik Eğitim Kongresi. (16-18 Eylül 2002). Ankara: ODTÜ Kültür ve Kongre Merkezi.
- Eğitimi Araştırma ve Geliştirme Daire Başkanlığı (EARGED) (2006). İlköğretim (5+3) matematik programı değerlendirme raporu: Ankara.
- Ersoy, Y. ve Erbaş, K. (2005). Kassel projesi cebir testinde bir grup Türk öğrencinin genel başarısı ve öğrenme güçlükleri. *İlköğretim Online*, 4(1), 18-39.
- Goldin, G. A. (1998b). Representational systems, learning, and problem solving in mathematics. *The Journal of Mathematical Behavior*, 17(2), 137-165.
- Goldin, G. A. & Janvier, C. (1998). Representations and the psychology of mathematics education. *The Journal of Mathematical Behavior*, 17(1), 1-4.
- Goldin, G. A. & Shteingold, N. (2001). Systems of representations and the development of mathematical Concepts. In A. A. Cuoco & F. R. Curcio (Ed.), The roles of representation in school mathematics: 2001 Yearbook (pp. 1-23). Reston, VA: NCTM.
- Janvier, B. D., Bednarz, N. & Belanger, M. (1987). Pedagogical considerations concerning the problem of representation. In C. Janvier (Ed.) Problems of representation in the teaching and learning of mathematics (pp.109-122). Hillsdale, NJ: Lawrence Erlbaum Associates.
- Kılıç, Ç. (2009). İlköğretim beşinci sınıf öğrencilerinin matematiksel problemlerin çözümlerinde kullandıkları temsiller. Yayınlanmamış doktora tezi, Anadolu Üniversitesi, Eğitim Bilimler Enstitüsü.
- Kieran, C. (1992). The learning and teaching of school algebra. In: Grouws DA (ed.). Handbook of research on mathematics teaching and learning. New York: Macmillan Publishing Company.
- Lee, L. (1996). An initiation into algebraic culture through generalization activities. In N. Bednarz, C. Kieran and L. Lee (Ed.), Approaches to algebra: perspectives for research and teaching (pp. 87-106). Dordrecht, Netherlands: Kluwer.
- McGowan, M. & Tall, D. (2001). Flexible thinking, consistency and stability of responses: A study of divergence. Retrieved May 17, 2013 from <http://homepages.warwick.ac.uk/staff/-David.Tall/>.
- National Council of Teachers of Mathematics (NCTM) (2000). *Principles and standards for school mathematics*. Reston, VA: National Council of Teacher of Mathematics.
- Olkun, S. ve Toluk-Uçar, Z. (2006). *İlköğretimde matematik öğretimine çağdaş yaklaşımlar*. Ankara: Ekinoks eğitim danışmanlık hiz. ve bas. yay. dağ.
- Özgün-Koca, S. A. (1998). Student's use of representations in mathematics education. Paper presented at the annual meeting of the north American chapter of the international group for the psychology of mathematics education, NC: Raleigh.
- Romberg, T. & Spence, M. (1995). Some thoughts on algebra for the evolving work force. In C. Lacampagne, W. Blair, & J. Kaput (Ed.), The algebra initiative colloquium. Washington, DC: US Department of Education.
- Schneider, E. (1995). Testing the rule of three: A formative evaluation of the Harvard based calculus consortium curriculum. Dissertation abstracts international, 56(06), 2158A.
- Schultz, J. E. & Waters, M. (2000). Why representations?. *Mathematics Teachers*, 93(6), 448-453.
- Sert, Ö. (2007). Sekizinci sınıf öğrencilerinin cebir kavramlarının farklı temsil biçimleri arasında dönüşüm yapma becerileri. Yayınlanmamış yüksek lisans tezi, Ortadoğu Teknik Üniversitesi, Sosyal Bilimler Enstitüsü.
- Sevimli, E. (2009). Matematik öğretmen adaylarının belirli integral konusundaki temsil tercihlerinin uzamsal yetenek ve akademik başarı bağlamında incelenmesi. Yayınlanmamış yüksek lisans tezi, Marmara Üniversitesi, Eğitim Bilimleri Enstitüsü.
- Stacey, K. & MacGregor, M. (1997). Building foundations for algebra. *Mathematics in the Middle School*, 2(4), 253-260.
- Thomas, M. & Tall, D. (2001). The long-term cognitive development of symbolic algebra. In H. Chick, K. Stacey, J. Vincent, & J. Vincent (Ed.), 12th ICMI Study Conference: The future of the teaching and learning of algebra. Melbourne: University of Melbourne.
- Türk Dil Kurumu (TDK) (2013). Güncel Türkçe Sözlük. <http://www.tdk.gov.tr/> (20.09.2013).
- Yerushalmy, M. & Schwartz, J. L. (1993). Seizing the opportunity to make algebra mathematically and pedagogically interesting. In Romberg, T. A., Fennema, E., & Carpenter, T. P. (Ed.), Integrating research on the graphical representation of functions. Hillsdale, NJ: Lawrence Erlbaum Associates.

METHODICAL AND MULTIMEDIA ENVIRONMENT FOR THE ACQUISITION OF ICT COMPETENCES IN THE FIELD OF LOGO PROGRAMMING OF FUTURE COMPULSORY EDUCATION TEACHERS

Nataša ROGULJA

The Faculty of Teacher Education of the University of Zagreb
natasa.rogulja@gmail.com

Ljubica BAKIĆ-TOMIĆ
University NORTH Croatia
ljbakictomic@gmail.com

Tomislava LAUC

The Faculty of Philosophy of the University of Zagreb
tlauc@ffzg.hr

ABSTRACT: The purpose of this paper was to propose and explore the methodical and multimedia environment required for the acquisition of ICT competences in the field of Logo programming of future compulsory education teachers. According to the student teachers' education curriculum, among other ICT competence requirements, the future teachers are to acquire relevant knowledge and skills in Logo programming. In order to determine the level of competence acquired, a methodical-qualitative evaluation of the environment, in the form of a web application, has been conducted by 50 students of The Faculty of Teacher Education of the University of Zagreb. Research results show that the environment contributes to the more effective acquisition of ICT competences of future teachers, especially in the field of computer programming.

Key words: ICT competences, methodical competences, compulsory education teachers, Logo programming, multimedia environment.

INTRODUCTION

In the development of the National Curriculum Framework for pre-school education and general compulsory (7-14 years of age) and secondary education, which focuses on student competences, Ministry of Science, Education and Sports of the Republic of Croatia, in accordance with European and other countries, has adopted eight key competences for lifelong learning: *Communication in the mother tongue, Communication in foreign languages, Mathematical competence and basic competences in science and technology, Digital competence, Learning to learn, Social and civic competences, Sense of initiative and entrepreneurship, Cultural awareness and expression* (Ministry of Science, Education and Sports of the Republic of Croatia, 2011, p. 17).

The Faculty of Teacher Education of the University of Zagreb is training future pre-school and compulsory education teachers for their successful personal and professional development as teacher, professional and technician in the educational system (Măță, 2011). Student teachers, which will take on a roll as teacher of Informatics, require specific ICT knowledge and skills for effective and efficient use of digital learning tools in their teaching practice. When they graduate they receive a diploma which defines their ICT competences:

1. Using different operative systems and information technologies for educational purposes in compulsory education subjects; development and servicing of educational information systems and educational databases.
2. Development of various educational software with the help of information technology; ability to choose and use educational software.
3. Retrieval, processing and storage of computer data; text procesing, processing of sounds, drawings and images for educational purposes.
4. Using the Internet and network services: transmission, storage and authentication of various Internet information; using electronic mail.
5. Preparation and implementation of multimedia projects in Intranet/Internet environment (preparation of computer presentations, creation of web pages etc.); organization and participation in distance on-line communication and on-line learning.
6. Statistical analysis and presentation of data with the help of information technology.
7. Basic programming knowledge and skills.

The aforementioned ICT competences include methodical competences, with its didactical, pedagogical and psychological aspects, which define how student teachers use information technologies for educational purposes.

To achieve “Basic programming” competence, National plan and program for compulsory education, strictly defines “Problem solving and programming” lesson unit, which is conducted either by Logo programming language or by procedural programming language, like Basic and Pascal (Ministry of Science, Education and Sports of the Republic of Croatia, 2006, p. 310). Since The Faculty of Teacher Education of the University of Zagreb did not have any courses that would cover “Basic programming” competence, in the year 2013, we have started a new course for learning and teaching Logo for the 5th year students of Informatics module. In the first part of the course the student teachers learned philosophy, concepts and structures of Logo by listening to series of lectures and writing program assignments through which they learned how to program. In the second part of the course, the student teachers learned methodology of teaching compulsory education pupils Logo, developing multimedia projects which integrate different ICT skills and knowledge. This year, we developed a new methodical and multimedia environment as a *prototype – working raw material* for the acquisition of methodical and ICT competences in Terrapin Logo programming language, one of the dialects of Logo. Design, development and student teachers’ evaluation of the environment are presented in this paper.

Logo programming language

Logo belongs to the 3rd generation of programming languages and it was created in the year 1967 by Seymour Papert and Wally Feurzeig, at Bolt, Beranek and Newman in MIT. It represents constructivist learning environment and powerful cognitive tool that enables and enriches critical thinking, creativity and higher order learning in learners. Logo’s “idealistic” idea was to use computer in education as a “tutee” (Reeves, 1998, p. 18), where learners develop problem-solving skills by teaching computer (writing programs) to perform different tasks (write text, draw pictures, create 2D and 3D geometrical forms, create animations etc.). In this way, learners could actively construct their own knowledge, and become designers, artists, organizers and presenters of that knowledge (Reeves, 1998). Today, in education, Logo is mostly known for its “*turtle graphics*” principle, where learners write program commands to move “graphical cursor” in the form of a turtle and draw line graphics on screen. There are many dialects of Logo and in Croatian schools three are frequently used: Terrapin Logo, MSW Logo and UCBLogo.

Design and Development of methodical and multimedia environment

Methodical and multimedia environment was designed by *Adobe Flash CS4 Professional* program for developing web pages and animations. Environment was created as a *prototype – working raw material* to serve as project assignments through which student teachers: redevelop and reevaluate environment by changing technical quality, usability and scenario (Croizat, Hu & Trigano, 1999); redesign and upgrade didactic and multimedia materials for their colleague students and compulsory education pupils.

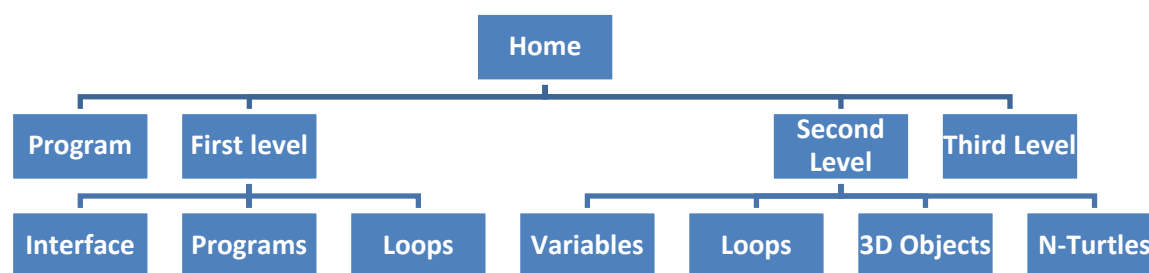

Figure 1. Navigational map of methodical and multimedia environment of Terrapin Logo language

Environment (Fig. 1) consists of five modules:

- **Home** – contains an archive of course material (PPT lecture presentations, student teachers’ projects analysis, homework, competition assignments, list of Terrapin Logo commands),
- **Program** – contains basic information (text and video presentation) of Logo and its development,
- **First Level:**
 1. **Interface** – textual and graphical description of Terrapin Logo interface,

2. **Programs** – textual and graphical description and video tutorial on writing simple programs (procedures) with fixed parameters,
 3. **Loops** – textual and graphical descriptions and video tutorials on writing programs (procedures) for drawing regular polygons, REPEAT loop, FOREACH loop.
- **Second Level:**
 1. **Variables** – textual and graphical description of definition of complex programs (procedures) with variables,
 2. **Loops** – textual and graphical descriptions and video tutorials for WHILE loop, FOR loop, MAKE command,
 3. **3D Objects** – textual and graphical descriptions and video tutorials on writing programs (procedures) for drawing three-dimensional objects: cube, rectangular cuboid and sphere.
 - **Third Level** – contains additional textual and graphical descriptions and video material of Logo as constructivist learning environment and *task type-oriented* teaching method (Papp-Varga, Szlávi & Zsakó, 2008) for problem-solving process through explorative “real life” lessons as integration of different school subjects.

METHODS

Objective

The aim of this research was to evaluate methodical and multimedia quality of the environment for the acquisition of methodical and ICT competences in learning and teaching Terrapin Logo programming language for the 5th year student teachers of Informatics module.

Sample

Methodical-qualitative evaluation of the environment has been conducted by 50 students of The Faculty of Teacher Education of the University of Zagreb, 5th year, module Informatics. Students were from two generations: 2012/2103 and 2013/2014. Given that the number of men was insignificantly small compared to the number of women, the sample has not been divided on sub-samples.

Instrument

Questionnaire was designed to gather information from student teachers of Informatics about methodical-qualitative evaluation of the environment. The questionnaire consists of three parts. The first part consists of four questions (2, 3, 4) which students teachers had to rate on an 5-point Likert-type scale in order to evaluate methodical quality of the environment for acquiring programming knowledge and skills in Terrapin Logo programming language. The second part consists of three questions (1, 5, 6) which students teachers had to rate on an 5-point Likert-type scale in order to evaluate their methodical and ICT competences in teaching Terrapin Logo programming language. The third part consists of two questions (7, 8) where student teachers had to evaluate methodical appropriateness of the environment (5-point Likert-type scale) for compulsory education pupils of younger age (7-11) and methodical quality of the environment (writing personal opinions) from textual (theoretical), visual (graphical) and multimedia (video presentations) context.

Data collection

The methodical and multimedia environment was uploaded as a web application on the Department of Informatics' official web page. One part of the data was collected by paper-pencil testing and other part by electronic mail.

RESULTS AND DISCUSSION

Descriptive results

Table 1. Mean values and standard deviations in evaluation of methodical quality of the environment for acquiring programming knowledge and skills in Terrapin Logo

No.	Question	1	2	3	4	5	Mean	Std. Deviation
2a	Evaluate methodical quality of the environment in textual (theoretical) context	0	0	11	20	19	4,16	3,25
2b	Evaluate methodical quality of the environment in visual	0	1	4	13	32	4,52	4,14

	(graphical) context							
2c	Evaluate methodical quality of the environment in multimedia (video presentations) context	0	0	3	16	31	4,56	4,12
3	Evaluate "virtual teacher-guide" of the environment	0	0	8	20	22	4,28	3,43
4	Evaluate the environmental level of motivation for learning Terrapin Logo	0	1	6	30	13	4,10	3,94

In question number 2, student teachers evaluated the methodical quality of the environment in textual (theoretical) context, with a mean score of 4,16 (SD=3,25), which means that most of them (39) consider textual context to be of very good and excellent quality. Visual (graphical) context of the environment was evaluated with a mean score of 4,52 (SD=4,14) which means that most of the student teachers (45) consider visual context to be of an excellent quality. Multimedia (video presentations) context of the environment was evaluated with a mean score of 4,56 (SD=4,12) which means that almost all the student teachers (47) consider multimedia context to be of an excellent quality.

In question number 3, student teachers evaluated "virtual teacher-guide" of the environment with a mean score of 4,28 (SD=3,43), which means that most of them (42) consider "virtual teacher-guide" exceptionally successful guidance.

In question number 4, student teachers evaluated environmental level of motivation for learning Terrapin Logo with a mean score of 4,10 (SD=3,94), which means that most of them (43) consider environment highly motivational.

Table 2. Mean values and standard deviation in evaluation of methodical and ICT competences in teaching Terrapin Logo

No.	Question	1	2	3	4	5	Mean	Std. Deviation
1	Evaluate the environment level of contribution to the acquisition of your methodical competences	0	0	5	24	21	4,32	3,68
5	Evaluate readiness to use this environment in your future work with compulsory education pupils	0	0	3	26	21	4,36	3,91

In question number 1, student teachers evaluated the environment level of contribution to acquisition of their methodical competences for teaching Terrapin Logo with a mean score of 4,32 (SD=3,68), which means that most of them (45) consider that the environment can greatly contribute to the development of their competences.

In question number 5, student teachers evaluated their readiness to use the environment in their future work with compulsory education pupils with a mean score of 4,36 (SD=3,91), which means that most of them (47) are ready to and are interested in using the environment in their future work.

In question number 6, student teachers evaluated their ability to design and develop similar environment for teaching compulsory education pupils Logo, using programs for developing web pages and animations. 32% of them stated they had the necessary ICT competences to design and develop such environment. 20% of them stated they did not have the necessary ICT competences, and 48% of them were not confident in their abilities to perform such a task. Most of the student teachers who expressed their readiness and were confident in their abilities, belong to first generation 2012/2013 of Logo programming language course, which implies that the second generation feels less confident about taking on such a task, which can be changed with adequate teaching practice after they received basic training in this field.

In question number 7, student teachers evaluated methodical appropriateness of the environment for compulsory education pupils of younger age (7-11), with a mean score of 3,98 (SD=3,75), which means that most of them (41) consider the environment to be highly appropriate for that specific age. In this case, student teachers had only one complaint on the textual (theoretical) context of the environment, suggesting upgrading it with a more detailed explanation of certain abstract terms, like "interface", "loop", "variable", "procedure", etc.

Student teachers' suggestions

In question number 8, student teachers evaluated methodical quality of the environment in a textual (theoretical), visual (graphical) and multimedia context. With regard to the textual context, they consider textual information to be "well synchronized with the multimedia elements (video presentations)" and highlighted the necessity to "adapt the textual information of the environment to compulsory education pupils of younger age (7-11) who would go through the learning process with the guidance of their teachers". The reason for this is

that the pupils of that age are not familiar with certain abstract terms, like “interface”, “loop”, “variable”, “procedure” etc.

With regard to the visual context, they consider visual (graphical) information to be “*sufficiently motivating for students, with good balance between visual and textual context and simple with concise information*”. They proposed “*increasing icon size in the entire environment and Home module and upgrading the environment with certain features that are visually attractive to children, like a picture or an animation of a turtle or some other character*”, which would play the role of a “virtual teacher-guide”. With regard to the design of the environment, they suggested redesigning it into a more adequate form by “*separating the content into two different modules: teacher module (guidelines and extra class materials) and pupil module (‘step-by-step’ guidelines in the learning process and detailed visual explanations of the program’s interface)*”.

With regard to the multimedia, they “*liked very much ‘step-by-step’ explanations of the learning material*” and highlighted the importance of the “video tutorial” approach in the learning process. They described video presentations as “*very clear and refreshing*” and suggested “*adding more presentations with more detailed animations of turtle movements, where each movement should be covered with the corresponding Logo command*”. They also suggested increasing video presentations for “*complex examples in programming assignments, where learners could watch the video and solve the problem at the same time*”. It would also facilitate learning process for learners with “*attention deficit disorder, who could stop the video at any point*” and recapitulate their knowledge. From the phonetic aspect, the student teachers highlighted “*insufficient quality of the speaker in terms of accent and intonation of individual words in sentences, which can make it difficult for learners to accept and memorize the content*”.

Although the student teachers were asked to evaluate these three aspects of the environment, they added one more on their own initiative – *Programming context*. They suggested certain improvements in explaining “*‘Tellall’ Logo command when working with multiple turtles and placing a separate link inside the environment for the explanation of program loops, which would be visible and accessible to the learners*”. For better understanding of certain program terms, like “*program loops and interior or exterior angles of regular polygons*”, they highlighted “*the necessity to translate them into Croatian language, what would help learners to understand its principles better*”.

CONCLUSION

Proposed methodical and multimedia environment presents an adequate tool for the acquisition of student teachers’ methodical and ICT competences in the field of constructivist programming language, Terrapin Logo. Student teachers of Informatics have evaluated the environment with very high grades from all of its aspects. They consider it to be something “*new in education and a very useful example of e-learning*”, which helps them to broaden their programming experience and upgrade their digital competence.

REFERENCES

- Crozat, S., Hu, O., & Trigano, P. (1999). A Method for Evaluating Multimedia Learning Software. *IEEE International Conference, Multimedia Computing and Systems, 1999.*, 1, 714-719.
Retrieved from <http://hal.archives-ouvertes.fr/docs/00/00/18/92/PDF/icmcs99.pdf>
- Mățã, L., (2011). Experimental research regarding the development of methodological competences in beginning teachers. *International Conference on Education and Educational Psychology (ICEEPSY 2011). Procedia – Social and Behavioral Sciences* 29, 1895-1904.
- Ministry of Science, Education and Sports of the Republic of Croatia (2011). *National Curriculum Framework for pre-school education and general compulsory and secondary education*. Zagreb: PRINTERA GRUPA.
- Ministry of Science, Education and Sports of the Republic of Croatia (2006). *National Plan and Program for general compulsory education*. Zagreb: GIPA.
- Papp-Varga, Z., Szlávi, P., & Zsákó, L. (2008). ICT teaching methods – Programming languages. *Annales Mathematicae et Informaticae* 35, 163-172.
Retrieved from <http://www.emis.de/journals/AMI/2008/ami2008-papp-szlavi-zsako.pdf>
- Reeves, C. T. (1998). The Impact of Media and Technology in Schools, A Research Report prepared for The Bertelsmann Foundation. *The University of Georgia*.
Retrieved from <http://treeves.coe.uga.edu/edit6900/BertelsmannReeves98.pdf>

ORTAOKUL FEN VE TEKNOLOJİ DERSLERİNDE LABORATUVAR KULLANIMINA YÖNELİK ÖĞRENCİ GÖRÜŞLERİ

STUDENTS' VIEWS FOR THE USE OF LABORATORY IN SECONDARY SCHOOL SCIENCE AND TECHNOLOGY COURSE

Burcu ANILAN
Eskişehir Osmangazi Üniversitesi, Eğitim Fakültesi
burcud@ogu.edu.tr

ÖZET: Bu araştırmanın amacı ortaokul öğrencilerinin fen ve teknoloji derslerindeki laboratuvar kullanımına yönelik görüşlerini belirlemektir. Araştırma var olan durumu ortaya koymaya çalışan ve nitel yöntemle gerçekleştirilen betimsel bir araştırmadır. Araştırmanın verileri araştırmacı tarafından geliştirilen yarı yapılandırılmış görüşme formu ile toplanmıştır. Veriler Eskişehir il merkezindeki ortaokullarda öğrenim gören 20 yedinci sınıf öğrencisinden toplanmıştır. Veriler betimsel analiz tekniği ile çözümlenmiştir. Çözümlemede görüşme soruları ana tema olarak alınmış ve beş tema oluşturulmuştur. Verilerin çözümlenmesi sonucunda: derslerde laboratuvar kullanıldığı ancak bunun yeterli olmadığı; derslerde yapılan deneylerin ilgi çekici bulunduğu ve tümüyle beklentileri karşılamadığı; gerek laboratuvar koşullarının iyi olmaması gerekse öğretmenlerin tutum ve davranışlarındaki olumsuzluğun öğrencilerin hem derse olan ilgilerini hem de ders içindeki tutum ve davranışlarını olumsuz etkilediği görülmüştür.

Anahtar sözcükler: ortaokul, fen ve teknoloji dersi, laboratuvar, öğrenci görüşü

ABSTRACT: The purpose of this study of secondary school students in science and technology courses for laboratory is to determine their opinions. The research is a descriptive research which is trying to put out the existing state and is carrying out with qualitative research. The research data were collected by semi-structured interview form developed by the researcher. Data were collected from 20 seventh graders who study in secondary schools in the city of Eskişehir. Data were analyzed by descriptive analysis technique. Interview questions are taken as the main theme in the analysis and five themes were created. As a result of the data analysis: laboratory is used in class, but it is not enough; in the course of the experiments found interesting and which is not fully meet our expectations; both laboratory conditions are not good enough and the negativity of behaviors and attitudes of teachers effect adversely students and their attitudes and behaviors in lessons as well as affect their attention to the course.

Key words: secondary school, science and technology courses, laboratory, students' view

GİRİŞ

İnsanoğlu var olduğu günden beri içinde yaşadığı çevreyi, doğayı ve evrende olup biten her şeyi hep merak etmiştir. İnsanoğlunun çevresine ve doğaya duyduğu bu merak ve araştırma isteği fen bilimlerinin doğmasına öncülük etmiştir. Fen bilimleri, canlı ve cansız varlıkları, bunlar arasındaki ilişkileri sebep-sonuç ilişkisi içinde incelemeye çalışan bir bilim dalıdır. Fen bilimleri doğanın gerçeklerini bulmaya, olayları açıklamaya, kontrol etmeye ve önceden kestirmeye çalışır. Bu nedenle fen bilimleri insanoğlunun doğayı ve kendini anlama çabalarının bir ürünüdür (Collette ve Chiapetta, 1989).

Doğa ve doğa olaylarını doğru değerlendirebilmek için iyi bir fen eğitimi almış olmak şarttır. Bu nedenle çocuklara feni sevdirebilmek, her gün karşılaştıkları birçok olayın fenin birer parçası olduğunu gösterebilmek için yaşadıkları çevreyi büyük bir fen laboratuvarı haline getirmek gerekmektedir. Laboratuvar, bazı kavram veya konuların öğrenciye bizzat yaptırarak, denenerek veya gösterilerek öğretildiği sınırları belirlenmiş ve kontrol edilebilir bir ortam (Güneş vd., 2013) olarak tanımlanabilir. Laboratuvar, bireylerin zihinsel becerilerini ve el becerilerini bir arada kullanmaları ve geliştirmeleri için onlara fırsatlar sunan bir yöntem olarak da bilinmektedir.

Laboratuvar yöntemi, fen bilimleri öğretiminde en sık başvurulan, etkili ve kalıcı öğrenmeyi sağlayan bir yöntemdir. Laboratuvar yöntemi, zihinsel etkinliklere önem veren, öğrencilerin bireysel ya da gruplar halinde çalışmasına olanak tanıyan, bireylerin el becerileri ve işlem yeteneklerinin gelişmesine yardım eden bir

yöntemidir. Laboratuvar yöntemi ile öğrenciler bilgiyi, ezberlemeden, gözlem ve uygulama yaparak, bilgiyi kullanma yollarını öğrenerek ve öğrendiklerini fen kavramları ile ilişkilendirerek kazanırlar. Bu yolla bireyler fen kavramlarını anlama, akılda tutma, eleştirel düşünme, fikir üretme, yorumlama ve günlük yaşamla ilişkilendirmede başarılı olurlar (Kaya ve Büyük, 2011).

Hiç kuşkusuz etkili fen öğrenimi yaparak ve yaşayarak öğrenmeye dayanır. Bu da fen öğretiminin laboratuvar ortamında yapılmasını gerektirmektedir. Fen öğretiminde laboratuvar uygulamalarının fene olan ilgiyi arttırdığı, fen konularının daha etkili ve kalıcı öğrenilmesine katkı sağladığı bilinmesine rağmen laboratuvar uygulamalarına çeşitli gerekçelerle gereken önemin verilmediği birçok araştırmayla ortaya konulmuştur (Akdeniz, 1997; Alpaut, 1993; Ayas, Çepni ve Akdeniz, 1994; Büyük, Demir ve Erol 2010; Çepni, Akdeniz ve Ayas, 1995; Değirmençay, 1999; Ekici, 1996; Ekici vd., 2002; Erten, 1991; Güneş vd., 2013; Gürdal, 1991; Karaca, Uluçınar ve Cansaran, 2006; Kaya ve Büyük, 2011; Saka, 2002). Oysa fen öğretiminde laboratuvar da gerçekleştirilen deneysel uygulamalar öğrenciler için çok büyük önem taşımaktadır. Özellikle öğrencilerin anlamakta ve kavramakta güçlük çektiği fen konularını laboratuvar ortamında yaparak yaşayarak öğrenmelerinin daha kolay, etkili ve kalıcı olduğu alan yazında sıkça vurgulanmaktadır (Çallıca vd., 2001; Gürdal, 1997; Güneş vd., 2011; Güzel, 2001; Hofstein, 2004; Singer, Hilton ve Schweingruber, 2005). Ancak laboratuvar uygulamalarının istenen nitelikte gerçekleştirilmesi öğretmenlerin nitelikleri ve tutumlarıyla yakından ilişkilidir. Nitekim bu konuda yapılan araştırmalar laboratuvar uygulamalarının malzeme yetersizliği, ders saatinin az olması, ortamın uygun olmaması, laboratuvar konusunda yeterli bilgiye sahip olunmaması, laboratuvar ortamında kontrolünün zor olması gibi nedenlerle gereğince yapılamadığını göstermektedir (Kaya ve Büyük, 2011). Daha önceki çalışmalarda laboratuvar kullanımının değişik nedenlerle yeterince yapılmadığı saptanmış olmasına karşın (Güneş vd., 2013) bunun öğrencilerce nasıl görüldüğüne pek değinilmemiştir. Bu nedenle bu çalışmada ortaokul fen ve teknoloji derslerindeki laboratuvar kullanımının öğrenci görüşlerine göre belirlenmesi amaçlanmıştır.

YÖNTEM

Ortaokul öğrencilerinin fen ve teknoloji derslerindeki laboratuvar kullanımına yönelik görüşlerini belirlemeyi amaçlayan bu çalışmada nitel bir araştırmadır. Araştırma var olan durumu ortaya koymaya çalışan betimsel bir çalışmadır. Araştırmanın verileri araştırmacı tarafından hazırlanan yarı yapılandırılmış görüşme formu ile toplanmıştır. Görüşme sorularının kapsam geçerliği için uzman görüşlerine başvurulmuştur. Veriler Eskişehir il merkezindeki ortaokullarda öğrenim gören 20 yedinci sınıf öğrencisinden toplanmıştır. Görüşmeler araştırmacı tarafından, gönüllülük esasına göre ve izin alınarak araştırmaya katılan öğrencilerin öğrenim gördüğü okullarda yapılmıştır. Görüşmeler öğrenci kantininde ve sınıflarda yapılmış ve ortalama 8-12 dakika sürmüştür. Ses kaydına alınan görüşmeler önce yazıya aktarılmış ve katılımcı teyidi sağlanmıştır. Bu amaçla görüşmecilerden rasgele seçilen 5 öğrenciyle kendileriyle yapılan görüşmenin dökümleri paylaşılmıştır. Elde edilen veriler betimsel analiz tekniğiyle çözümlenmiştir. Verilerin çözümlenmesinde görüşme soruları ana temalar olarak alınmıştır. Buna göre; Fen ve teknoloji derslerinde laboratuvar kullanımı; Laboratuvarda yapılan deneylerin ilgi çekiciliği; Fen ve teknoloji öğretmeni olunması durumunda laboratuvarda yapılacaklar; Laboratuvar uygulamalarını etkileyen faktörler ve Laboratuvar kavramına yüklenen anlam olmak üzere beş tema oluşmuştur.

Araştırmanın geçerliğini sağlamak için katılımcı ve meslektaş teyidi alınmış ve katılımcıların görüşlerinden doğrudan alıntılar yapılmıştır. Araştırma güvenilirliği için ise Stemler'in (2001) tekrarlanabilirlik ya da tek kodlayıcı güvenilirliği dediği yol izlenmiştir. Buna göre araştırmacı kodlamaları yaptıktan belli bir süre sonra aynı veri setini tekrar kodlamış ve kodlama güvenilirliğine bakılmıştır. Bunun için Miles ve Huberman'ın (1994) güvenilirlik formülü kullanılmıştır. Hesaplamalar sonucunda güvenilirlik %95 çıkmış ve araştırma güvenilir kabul edilmiştir.

BULGULAR

Fen ve Teknoloji Derslerinde Laboratuvar Kullanımı

Araştırmaya katılan öğrencilerin Fen ve teknoloji dersinde laboratuvar kullanımına yönelik görüşleri farklılık göstermektedir. Öğrencilerin yarısı (n=10) derslerinde laboratuvar kullandıklarını ifade etmektedir. Öğrenciler laboratuvar da ders yapmanın öğrenmeyi kolaylaştırdığı ve kalıcılığı arttırdığı görüşündedirler. Konuyla ilgili bazı öğrenci ifadeleri şöyledir:

“Derslerimizde laboratuvarı kullanıyoruz. Dersi anlamamızı sağlıyor.” (Ö5).

“... Çünkü deney yapmak için uygun bir yer. Bir şeyleri deneyerek insan daha iyi öğrenir” (Ö14).

“Evet, laboratuvarı kullanıyoruz. Ders kitabımızda deneyler oluyor. Deneyleri laboratuvar da yapıyoruz. Görerek konuları daha iyi anlıyoruz.” (Ö16).

Öğrenci ifadelerinde de görüldüğü gibi öğrenciler yaparak yaşayarak öğrenmenin önemine dikkat çekmektedirler. Bu da aslında öğrenmenin bir yaşantı ürünü olduğuna yapılan bir vurgudur.

Araştırmaya katılan öğrencilerin bir kısmı ise (n=6) derslerini bazen laboratuvarında yaptıklarını belirtmişlerdir. Öğrenciler ifadelerinde özellikle öğretmen tutumlarına işaret etmektedirler. Derslerinin belli dönem laboratuvarında yapıldığını ancak bu dönemden sonra derslerin sınıfta yapılmaya başladığını vurgulamışlardır. Öğrencilerin bazı ifadeleri şöyledir:

“Birinci dönem kullanıyorduk ama ikinci dönem derslerimizin çoğunu sınıfımızda yapıyoruz. Birinci dönem laboratuvarında çeşitli deneyler yapıyorduk. Şimdi yapmıyoruz.” (Ö12)

“Okulun ilk dönemi derslerimizin çoğu laboratuvarında geçiyordu. İkinci dönem hiç kullanmadık. Çünkü hocamız derslerin sınıfta daha iyi, akıcı ve etkili olduğunu söylüyor.” (Ö13).

“Evet, laboratuvarı bir ara kullanıyorduk. Belli bir zaman sonra dersi sınıfta işlemeye başladık ve hala sınıfta işliyoruz.” (Ö18).

Öğrencilerin ifadelerinden de anlaşılacağı üzere derslerin belli bir dönem laboratuvarında yapıldığı ve öğretmenin kararıyla derslerin sınıfta yapılmaya başlandığı görülmektedir. Ancak öğretmenin kararını etkileyen faktörlerin neler olduğu belli olmamakla birlikte, laboratuvarında sınıf kontrolünün zor olması öğretmenin böyle bir karar almasında etken olabilir.

Araştırmaya katılan 4 öğrenci ise (Ö9, Ö11, Ö19, Ö20) laboratuvarı hiç kullanmadıklarını belirtmiştir. Bu görüşte olan öğrenciler neden laboratuvarında ders yapmadıklarına ilişkin herhangi bir açıklamada bulunmadıklarından yorum yapmak güçtür. Ancak öğretmen kararının etkili olduğu düşünülebilir.

Laboratuvarında Yapılan Deneylerin İlgi Çekiciliği

Araştırmaya katılan öğrencilerden ikisi hariç (Ö19 ve Ö20) geri kalanın tamamı, fen ve teknoloji dersinde laboratuvarında yapılan ya da kendilerinin yaptıkları deneylerin ilgilerini çektiğini belirtmiştir. Deneyleri ilginç bulmadıklarını belirten iki öğrencinin de aslında ilginç bulmadığı deneyler değildir. Bu iki öğrenci deney yapamadıkları için deneyleri ilginç bulmadıklarını ifade etmektedir. Öğrenciler görüşlerini şu şekilde ifade etmişlerdir:

“Hayır, ilgimi çekmiyor. Laboratuvarında deney yapmıyoruz genellikle yazı yazıyoruz.” (Ö19).

“Deney Yapmıyoruz ki ilgimizi çeksin.” (Ö20).

Deneyleri ilgi çekici bulan öğrenciler ise daha fazla beklenti içindeler. Bu durum gerçekte öğrencilerin fene ilgi duyduklarını göstermekle birlikte içerik ya da içeriğin sunumuyla ilgili beklentilerinin de gerçekleşmediğinin bir göstergesi olabilir. Okulda, derslerde yapılan deneyleri ilginç bulmalarına rağmen daha fazla beklenti içinde olan öğrencilerin bazılarının ifadeleri de şöyledir:

“Deneyler ilgimi çekiyor. Ancak daha büyük riskli şeyler olsa daha iyi olurdu.” (Ö1).

“Evet, çekiyor. Daha yeni deneylerin olmasını isterdim. Yeni araçlarla deneyleri yapmak isterdim.” (Ö16).

“Evet çekiyor. Keşke daha büyük deneyler yapabilesek...” (Ö3).

Görüldüğü üzere öğrenciler fen derslerinde yapılan deneyleri ilginç bulmakla birlikte daha fazla beklenti içindeler.

Fen Ve Teknoloji Öğretmeni Olunması Durumunda Laboratuvarında Yapılacaklar

Araştırmaya katılan öğrenciler, eğer kendileri fen ve teknoloji öğretmeni olsalardı, laboratuvara daha fazla zaman ayıracıklarını, daha küçük gruplarla çalışacaklarını, öğrencilere daha fazla uygulama olanağı sağlayacaklarını, daha ilgi çekici ve günlük yaşamda işe yarayacak deneyler yaptıracağını ifade etmişlerdir. Öğrencilerden bazılarının ifadeleri şöyledir:

“Daha büyük laboratuvarında, daha küçük gruplar halinde yapardım.” (Ö2).

“Daha çok saat ayırırdım. Eğer fen iki saat ise bir saatini, dört saat ise iki saatini laboratuvara ayırırdım.” (Ö3).

“Öğrencilerin hepsine deney yaptırırdım. Daha ilgi çekici deneyler yapardım. Sabun üretimi gibi işe yarayacak deneyler yaptırırdım.” (Ö6).

“Eğer fen ve teknoloji öğretmeni olsaydım; öğrencilerimin derste sıkılmasını önlemek için elimden geleni yapardım. Laboratuvarında ise grup çalışmalarını ve etkinlikleri oldukça sık yaparak çalışmalarını geliştirirdim.” (Ö13).

“Ders kitabındaki bütün deneyleri öğrencilerimle laboratuvarında yapardım. Öğrencilerim konuları daha iyi anlardı.” (Ö16).

Öğrenci ifadelerinden de anlaşılacağı üzere öğrencilerin fen ve teknoloji derslerinde öğretmenlerden birtakım beklentileri vardır. Öğrenme öğretme sürecinden etkin verimin alınabilmesi için öğrencilerin belirtmiş olduğu bu örtük beklentilerin dikkate alınmasında yarar vardır.

Laboratuvar Uygulamalarını Etkileyen Faktörler

Öğrenciler laboratuvar çalışmalarını olumsuz etkileyen unsurlardan da söz etmişlerdir. Bunlar genellikle laboratuvar ortamıyla ve öğretmen davranışlarıyla ilişkilidir. Öğrenciler laboratuvardaki oturma düzeni ve oturma yerlerinden (Ö1, Ö3, Ö4); laboratuvar malzemelerin eski ve yetersiz oluşundan (Ö2, Ö9, Ö12); laboratuvarın çok gürültülü oluşundan (Ö6, Ö7, Ö11, Ö18); öğretmenin baskıcı ve deney malzemelerine zarar vermeleri endişesiyle malzemelere dokundurmasından (Ö5, Ö6, Ö8, Ö12, Ö13, Ö14, Ö15, Ö17) sıkıntı duymaktadırlar. Öğrencilerin konuya ilişkin ifadelerinden bazıları şöyledir:

“Sandalye ve oturma kavgası yapılıyor.” (Ö2).

“Sınıfın gürültülü olması, malzemeler kırılacak diye öğretmenin dokundurmasını.” (Ö6).

“... bunlardan bazıları örneğin malzemelerimiz olmuyor ve hocamızın bazı baskıları bizi dersten soğutuyor ve ilgimizi dağıtıyor. Fen ve teknoloji dersinden soğuyoruz.” (Ö12).

“Öğretmenimizin bize bazen hakaret etmesi.” (Ö14).

“Olumsuz etkileyen durumlar var. Eşyalar cam deney tüpleri kırılırsa diye korkuyorum.” (Ö15).

Görüldüğü gibi gerek laboratuvar koşullarının iyi olmaması gerekse öğretmenin tutum ve davranışlarındaki olumsuzluk öğrencilerin hem derse olan ilgilerini hem de ders içindeki tutum ve davranışlarını olumsuz etkilemektedir. Söz konusu olumsuzlukların giderilmesi etkili öğrenme-öğretme süreçlerinin ve ortamlarının oluşturulması bakımından oldukça önemlidir.

Laboratuvar Kavramına Yüklenen Anlam

Araştırmaya katılan öğrenciler için laboratuvar kavramı farklı çağrışımlar oluşturmakla birlikte bu kavramlar iki temel kategoride toplanmaktadır. Deneylerin yapıldığı ve çeşitli deney malzemelerinin bulunduğu mekan olarak laboratuvar (Ö1, Ö5, Ö6, Ö7, Ö8, Ö9, Ö11, Ö12, Ö14, Ö15, Ö19) ve yaparak yaşayarak öğrenmenin gerçekleştiği yer ve eğlenceli öğrenme ortamı olarak laboratuvar (Ö2, Ö3, Ö4, Ö10, Ö13, Ö16, Ö17, Ö18). Öğrencilerin bu konudaki görüşleri şöyledir:

“Deneylerin yapıldığı ve çeşitli malzemelerin bulunduğu yer.” (Ö1).

“Yaşayarak öğrenilen yer.” (Ö2)

“Dersin eğlenceli geçtiği, yaparak öğrendiğimiz bir ortam.” (Ö4).

“Deneylerin yapıldığı uygun derslik.” (Ö14).

“Dersin daha iyi anlaşıldığı ve deneyler yaparak işlendiği yer.” (Ö17).

Yukarıdaki ifadelerden de anlaşıldığı üzere öğrenciler laboratuvara hem somut hem de soyut anlamlar yüklemektedir. Buna göre laboratuvar somut bakış açısıyla fiziki bir mekan, soyut bakış açısıyla da bir öğrenme biçimidir. Öğrencilerin laboratuvarı fiziki bir mekan olmanın dışında bir öğrenme yolu olarak görmeleri aslında dikkat çekicidir.

SONUÇ

Ortaokul öğrencilerinin fen ve teknoloji derslerindeki laboratuvar kullanımına yönelik görüşlerini belirlemeyi amaçlayan bu araştırmada aşağıdaki sonuçlara ulaşılmıştır.

1. Araştırmaya katılan öğrencilerin büyük çoğunluğu derslerinde laboratuvar kullandıklarını ifade etmekle birlikte bunun yeterli olmadığı görüşündedir.
2. Araştırmaya katılan öğrencilerin hemen hemen tamamı fen ve teknoloji dersinde laboratuvarda yapılan ya da kendilerinin yaptıkları deneylerin ilgilerini çektiği ancak tümüyle beklentilerini karşılamadığı düşünülmektedir.
3. Araştırmada yer alan öğrenciler, eğer kendileri fen ve teknoloji öğretmeni olsalar, laboratuvara daha fazla zaman ayıracaklar, daha küçük gruplarla çalışacaklar, öğrencilere daha fazla uygulama olanağı sunacaklar, daha ilgi çekici ve günlük yaşamda işe yarayacak deneyler yaptıracaklarını belirtmektedirler.
4. Gerek laboratuvar koşullarının iyi olmaması gerekse öğretmenlerin tutum ve davranışlarındaki olumsuzluk, öğrencilerin hem derse olan ilgilerini hem de ders içindeki tutum ve davranışlarını olumsuz etkilemektedir.
5. Araştırmaya katılan öğrenciler için laboratuvar kavramı, deneylerin yapıldığı ve çeşitli deney malzemelerinin bulunduğu mekan ve yaparak yaşayarak öğrenmenin gerçekleştiği eğlenceli öğrenme ortamı anlamına gelmektedir.

KAYNAKÇA

- Akdeniz, A. R. (1997). Ders geeme ve kredi sisteminde fizik mfredatlarının uygulanmasının deęerlendirilmesi. *ukurova niversitesi Eęitim Fakltesi Dergisi*, 15, 79-85.
- Alpaut, O. (1993). Fen eęitiminin verimli ve iřlevsel hale getirilmesi. Ortaeęretim Kurumlarında Fen Eęretimi ve Sorunları Sempozyumu. Ankara: TED.
- Ayas, A., epni, S. & Akdeniz, A. R. (1994). Fen bilimleri eęitiminde laboratuvarın yeri ve nemi; tarihsel bir bakış. *aędař Eęitim Dergisi*, 204, 21-25.
- Byk, U., Demir, S. ve Erol, M. (2010). Fen ve teknoloji dersi eęretmenlerinin laboratuvar alıřmalarına ynelik yeterli grřlerinin farklı deęiřkenlere gre incelenmesi. *Tubav Bilim Dergisi*, 3(4), 342-349.
- Collette, E. L. & Chiapetta, A. (1989). *Teaching science in middle and secondary schools*. Toronto: Berril Publishing Company.
- allica, H., Erol, M., Sezgin, G., Kavcar, N. (2001). İlkretim kurumlarında laboratuvar kullanımına iliřkin bir alıřma. IV. Fen Bilimleri Kongresi. Ankara: MEB. Basımevi.
- epni, S., Akdeniz, A. R. & Ayas, A. (1995). Fen bilimlerinde laboratuvarın yeri ve nemi (III): lkemizde laboratuvar kullanımı ve bazı neriler. *aędař Eęitim*, 206, 24-28.
- Deęirmenay, ř. A. (1999). Fizik eęretmenlerinin laboratuvar becerileri, KT Fen Bilimleri Enstits, (Yayımlanmamıř Yksek Lisans Tezi), Trabzon.
- Ekici, G. (1996). Biyoloji eęretmenlerinin eęretimde kullandıkları yntemler ve karřılařtıkları sorunlar. Ankara niversitesi Sosyal Bilimler Enstits, (Yayımlanmamıř Yksek Lisans Tezi), Ankara.
- Ekici, F. T., Ekici, E. & Tařkın, S. (2002). Fen laboratuvarlarının iinde bulunduęu durum. V. Ulusal Fen Bilimleri ve Matematik Eęitimi Kongresi. Ankara: Orta Doęu Teknik niversitesi.
- Erten, S. (1991). Biyoloji laboratuvarlarının nemi ve laboratuvarda karřılařılan problemler. Gazi niversitesi Fen Bilimleri Enstits, (Yayımlanmamıř Yksek Lisans Tezi), Ankara.
- Gneř, M. H., třener, N., Topal Germi, N. & Can, N. (2013). Fen ve teknoloji dersinde laboratuvar kullanımına ynelik eęretmen ve đrenci deęerlendirmeleri. *Dicle niversitesi Ziya Gkalp Eęitim Fakltesi Dergisi*, 20, 1-11.
- Grdal, A. (1991). İlkokul fen eęitiminde laboratuvar ve ara kullanımı. *Marmara niversitesi Eęitim Fakltesi Dergisi*, 3, 145-155.
- Gzel, H. (2001). İlkretim okullarındaki I ve II kademedeki fen bilgisi derslerinde laboratuvar etkinlikleri ve ara kullanımı dzeyi. IV. Fen Bilimleri Kongresi, Ankara: MEB Basımevi.
- Grdal, A. (1997). Fen eęretiminde laboratuvar etkinlięinin bařarıya etkisi. *Yařadıka Eęitim Dergisi*, 55, 14-16.
- Hofstein, A. (2004). The laboratory in chemistry education; thirty years of experience with developments, implementation and research. *Chemistry Education: Research and Practice*, 5(3), 247-264.
- Karaca, A., Uluınar, ř., Cansaran, A. (2006). Fen bilgisi eęitiminde laboratuvarda karřılařılan glklerin saptanması. *Milli Eęitim Dergisi*, 170, 250-259.
- Kaya, H. & Byk, U. (2011). Fen bilimleri eęretmenlerinin laboratuvar alıřmalarına ynelik yeterlikleri. *Erciyes niversitesi Fen Bilimleri Enstits Dergisi*, 27(1), 126-134.
- Miles, M. B., & Huberman, A. M. (1994). *An expanded sourcebook qualitative data analysis*. Second Edition. California: Sage Publications, Inc.
- Saka, M. (2002). Sınıf eęretmenlięi đrencilerinin fen bilgisi laboratuvarı uygulamaları ve laboratuvar řartlarına iliřkin grřleri. V. Ulusal Fen Bilimleri ve Matematik Eęitimi Kongresi, Ankara: Orta Doęu Teknik niversitesi.
- Singer, S., Hilton, M., & Schweingruber, H. (2005). Needing a new approach to science labs. *The Science Teacher*, 72(7), 10.
- Stemler, S. (2001). An overview of content analysis. *Practical Assessment, Research & Evaluation*, 7(17).

EXAMINATION OF ATTITUDES OF COMPULSORY EDUCATION TEACHERS IN THE REPUBLIC OF CROATIA TOWARD THE INTEGRATION OF ICT TECHNOLOGY IN DAILY WORK

Ljubica BAKIĆ-TOMIĆ
University NORTH Croatia
ljbakictomic@gmail.com

ABSTRACT: There are a number of measurement instruments in the field of education the aims of which are to measure various aspects of educational technology. The instrument that we used in this study is a survey of social and technical factors affecting teachers' use of technology designed by E. Papanastasiou and C. Angeli in 2008. The sample of this study included 413 teachers teaching in public elementary schools in Zagreb. The aim of this study is to show social and technical factors that play an important role in the successful integration of ICT in schools and to answer the question to what extent and how each of these factors affects the successful integration of ICT in schools.

Key words: Teachers' use of ICT, social factors affecting teachers' use of technology, technical factors affecting teachers' use of technology, public elementary schools in Zagreb

INTRODUCTION

ICT has changed the processes of teaching and learning and has had a significant impact on education. The use of ICT in education in a productive way can be influenced by many factors. One of these factors is teachers' attitudes toward the use of technology in the teaching and learning processes. Rogers' Innovation Decision Process Theory [21] states that an innovation's diffusion is a process which occurs over a time period through five stages: Knowledge, Persuasion, Decision, Implementation and Confirmation. Accordingly, "the innovation-decision process is the process through which an individual (or other decision-making unit) moves (1) from initial knowledge about an innovation, (2) toward forming an attitude toward the innovation, (3) the decision of either adoption or rejection, (4) implementation and (5) confirmation of this decision" [21]. This theory explains how teachers' attitudes have either a direct or an indirect influence on the teachers' use of technology in classrooms [20].

Zhao and Cziko are of the opinion that aspects of individual attitudes are the main factors influencing a teacher's use of ICT [27]. The teachers must be convinced that the use of technology can help achieve learning objectives but also lift the learning process to a higher level. Many studies confirmed that the important predictor of future ICT use were teachers' attitudes toward it ([25], [16], [1], [15], [3], [14], [26]). Researchers ([23],[4]) found that certain teachers' attitudes are obstructions to the successful integration of ICT in schools. According to Kersaint et al. [12] teachers who have positive attitudes toward technology feel more comfortable using it and usually incorporate it into their teaching. It was also found that personal characteristics such as age and teaching experience had a negative correlation with attitudes whereas gender and teaching methods were found to be insignificant as predictors of teachers' attitudes toward ICT [24].

Teachers' attitude toward technology can predict teacher and student technology use, but also the use of various instructional methods ($p < 0.05$). Sang et al. [25] focused on the impact of Chinese student teachers' gender, constructivist teaching beliefs, teaching self-efficacy, computer self-efficacy, and computer attitudes on their prospective ICT use. The findings confirmed the results of the study by Palak and Walls [16], that the strongest predictor of future ICT use were teachers' attitudes toward it.

One other aspect which has an influence on the adoption and use of ICT among teachers is computer self-efficacy [20], which refers to the ability of applying one's skills when using technology for broader tasks. A greater sense of computer self-efficacy has been shown to influence individuals' choice regarding computer usage and adoption in general. In the case of teachers, research suggests that a strong sense of computer self-efficacy among teachers affects how often and the way ICT is used in everyday instructional practice ([5],[6],[18]).

Research on teachers' use of ICT in education suggests that attitudes have either a direct or indirect influence on a teachers' use of technology in classrooms. The direct influence of attitudes can be categorised into two groups: attitudes toward technology ([8],[22]) and attitudes to ICT use in education ([2],[1],[9],[11],[19]). One example

where attitudes have an indirect influence on ICT use in education is given in the research conducted by Cox, Preston and Cox [7] in which attitudes seemed to influence teachers' motivation to use ICT. According to the authors, motivation is a factor which exerts a direct influence. Teachers' attitude toward ICT will also promote innovative use of ICT [10]. Positive attitudes to ICT and its use in education are often considered as enabling factors and negative attitudes as disabling factors ([10],[13],[19]). There seems to be some lack in data however on the link between the attitude toward use of ICT in school and ICT in daily work. According to some researches there seems to be a link between the self-efficacy theory and attitudes to ICT use as positively related to experience. It can be concluded that familiarity with technology use makes people regard ICT use more positively, which also results in a greater feeling of self-efficacy [18].

METHODS

Research aim

The aim of this research was to examine attitudes of compulsory education teachers in the Republic of Croatia toward the daily use of ICT in teaching.

Research problem

- To determine descriptive values for teachers' attitudes toward the use of ICT in schools
- To determine if there's a correlation between teachers' working life and age, and their attitudes toward the use of ICT in schools
- To determine if there is any statistically significant difference between attitudes toward the use of ICT between teachers of compulsory education working in both lower and higher grades
- To determine correlation between weekly frequency of the ICT use in specific subjects and their attitude toward the ICT

Methodology and Sample

Research instrument for this study was a questionnaire by Papanastasiou and Angeli[17]. The questionnaire was a part of a large research project and authors constructed it in 2008 for the needs of their studies. It consisted of seven sections: 1) demographic information related to teachers, 2) knowledge of computer software, 3) frequency of software use for personal purpose, 4) frequency of software use for specific subjects in classroom practise, 5) teachers' attitudes toward ICT integration, 6) teachers' perceived self-confidence in the ICT use, 7) school climate and technical support. For the purpose of this research we only used section 1, section 3 and section 5. All other sections except for section one consisted of a Likert-type scale, with possible answers: 1-completely disagree, 2-disagree, 3-neutral, 4-agree, 5-completely agree.

This research was conducted in the Republic of Croatia in 2013. The survey was done in 18 compulsory education schools in Zagreb, the capital of Croatia, where $\frac{1}{4}$ of the global population of the Republic of Croatia lives. The sample consisted on the whole of 413 compulsory education teachers. Compulsory education in the Republic of Croatia lasts 8 years and it is divided into two stages- lower grades (from first to fourth) and higher grades (from fifth to eighth). The sample consists of 91,3 % of female teachers and 8,7 % of male teachers. 47 % teachers in lower grades 43,1 % in higher grades and 9,9 % in both lower and higher grades. The average teachers' age in the sample was 40,65, ranging from 24 to 65. Teachers who were tested have an average of 14,9 years experience in teaching, ranging from less than one year (only 2,7 %) to 45 years.

RESULTS AND DISCUSSION

Table 1. Descriptive analysis of teachers' attitudes toward the use of ICT in schools (sample consisted of 410 teachers)

Attitudes	Mean	Std. Deviation	Std. Error Mean
AT1	4,338	0,889	0,046
AT2	1,813	1,073	0,055
AT3	2,521	1,269	0,066
AT4	1,741	1,067	0,055
AT5	3,923	1,053	0,054

AT6	1,573	0,961	0,049
AT7	4,488	0,814	0,042
AT8	3,739	1,161	0,060
AT9	3,667	1,142	0,059
AT10	3,334	1,231	0,064
AT11	2,192	1,243	0,064
AT12	4,083	0,900	0,046
AT13	3,109	1,168	0,060
AT14	3,912	1,027	0,053
AT15	2,083	1,089	0,056

LEGEND: AT 1- I feel comfortable with the idea of the computer as a tool in teaching and learning, AT 2 - the use of computers in teaching and learning stresses me out, AT 3 - if something goes wrong I will not know how to fix it, AT 4 - the idea of using a computer in teaching and learning makes me skeptical, AT5- the use of the computer as a learning tool excites me, AT6- the use of computers in teaching and learning scares me, AT7 - the computer is a valuable tool for teachers, AT8- the computer will change the way I teach, AT9- the computer will change the way students learn in my classes, AT10- I can do what the computer can do equally as well, AT11- The computer is not conducive to student learning because it is not easy to use, AT12- The computer helps students understand concepts in more effective ways, AT13- The computer helps students learn because it allows them to express their thinking in better and different ways, AT14- The computer helps teachers to teach in more effective ways, AT15- The computer is not conducive to good teaching because it creates technical problems.

Following statements reflect positive teachers' attitudes: teachers feel comfortable while using computers as tools in teaching and learning, the computer is a valuable tool in teaching, the computer helps students learn because it allows them to express their thinking in better and different ways and it helps students understand concepts in more effective ways ($M > 4$). Statements that reflect negative teachers' attitudes had a very low score, which in other words means that they are rarely present. Those statements that indicate moderately strong teachers' attitude toward the use of ICT are possibly showing that teachers are sceptical about computers helping students to understand concepts in a more effective way. This can point to moderately expressed belief that the computer will change the way students learn.

Table 2. Correlation between teachers' attitudes toward the ICT use and age and work life (N=410)

Attitudes	Teachers' age in years	Teachers' work life
AT1	-,347**	-,350**
AT2	,356**	,327**
AT3	,301**	,252**
AT4	,212**	,175**
AT5	-,230**	-,242**
AT6	,295**	,258**
AT7	-,225**	-,244**
AT8	-0,76	-0,70
AT9	-,058	-,033
AT10	,012	,016
AT11	,334**	,311**
AT12	-,066	-,050
AT13	-,017	-,014
AT14	-,128**	-,130**
AT15	,230**	,210**

*Correlation is significant at the 0.05 level (2-tailed). **Correlation is significant at the 0.01 level (2-tailed).

LEGEND: AT 1- I feel comfortable with the idea of the computer as a tool in teaching and learning, AT 2 - the use of computers in teaching and learning stresses me out, AT 3 - if something goes wrong I will not know how to fix it, AT 4 - the idea of using a computer in teaching and learning makes me skeptical, AT5- the use of the computer as a learning tool excites me, AT6- the use of computers in teaching and learning scares me, AT7 - the computer is a valuable tool for teachers, AT8- the computer will change the way I teach, AT9- the computer will change the way students learn in my classes, AT10- I can do what the computer can do equally as well, AT11- The computer is not conducive to student learning because it is not easy to use, AT12- The computer helps students understand concepts in more effective ways,

AT13- The computer helps students learn because it allows them to express their thinking in better and different ways, AT14- The computer helps teachers to teach in more effective ways, AT15- The computer is not conducive to good teaching because it creates technical problems.

Out of 15 possible correlations between attitude toward the use of ICT and age, 10 are statistically significant. All statistically significant correlations are low and it can be generally said that age shows low correlation with attitudes toward the use of ICT in education. Principally older teachers show more negative attitudes toward the use of ICT in schools. Younger teachers seem to consider ICT as a valuable tool and that it can positively influence both teachers and pupils.

Similar correlations have been found in connection with work life. Out of 15 possible correlations between attitude and age, 10 are statistically significant. All statistically significant correlations have been found in the same attitude items, seem to be going in the same direction and show similar values, as it has been shown in the correlation analysis between the age and use of ICT in schools.

No statistically significant differences have been found in attitudes toward the use of ICT between higher and lower grades teachers, which leads us to the conclusion that all compulsory education teachers in Croatia have equally positive attitudes toward the use of ICT in schools (the results of the differences analysis have not been shown in tables because of the huge amount of data).

Table 3. Correlation between teachers' attitudes toward the ICT use and weekly frequency of ICT use for specific subjects (N=410)

	Math	Science	Art	Music	Physical Education	Croatian
AT1	,142**	,153**	,039	,015	,092	,141
AT2	-,141**	-,133**	-,039	-,017	,092	-,137
AT3	-,083	-,125*	-,067	-,071	-,112*	-,047
AT4	-,055	-,067	-,043	,017	-,071	-,047
AT5	,042	,089	,100*	-,032	-,063	,064
AT6	-,132*	-,122*	,042	-,032	-,063	-,142
AT7	,059	,041	,042	-,039	,041	,032
AT8	,025	,041	,062	-,011	-,014	,051
AT9	,024	,045	,079	-,003	-,025	,041
AT10	-,044	-,015	-,032	,004	-,008	,048
AT11	-,111*	-,062	-,023	-,068	,015	-,051
AT12	,010	,021	,047	-,054	-,017	-,047
AT13	-,032	-,081	-,025	-,116*	,032	-,073
AT14	,089	,128*	,095	-,002	,072	,076
AT15	-,098*	-,103*	-,074	,010	-,053	-,065

*Correlation is significant at the 0.05 level (2-tailed). **Correlation is significant at the 0.01 level (2-tailed).

LEGEND: AT 1- I feel comfortable with the idea of the computer as a tool in teaching and learning, AT 2 - the use of computers in teaching and learning stresses me out, AT 3 - if something goes wrong I will not know how to fix it, AT 4 - the idea of using a computer in teaching and learning makes me skeptical, AT5- the use of the computer as a learning tool excites me, AT6- the use of computers in teaching and learning scares me, AT7 - the computer is a valuable tool for teachers, AT8- the computer will change the way I teach, AT9- the computer will change the way students learn in my classes, AT10- I can do what the computer can do equally as well, AT11- The computer is not conducive to student learning because it is not easy to use, AT12- The computer helps students understand concepts in more effective ways, AT13- The computer helps students learn because it allows them to express their thinking in better and different ways, AT14- The computer helps teachers to teach in more effective ways, AT15- The computer is not conducive to good teaching because it creates technical problems.

Out of 15 possible correlations between attitudes toward the use of ICT in schools and the weekly frequency of ICT use for specific subjects, the largest number of statistically significant correlations have been found for Science (6), Maths (5), Art, Music and Physical Education (1), whereas no statistically significant correlations between attitudes and the weekly frequency of ICT use for Croatian. All statistically significant correlations are very low and it can be generally said that the weekly frequency of ICT for different school subjects shows low correlation between attitudes and the use of ICT in school in the desirable direction (positive attitudes toward the use of ICT, Table 3).

Table 4. Correlation between teachers' attitudes toward the use of ICT and weekly frequency of common ICT software regardless of specific subjects (N=410)

	MS Word	MS Excel	MS Power Point	MS Outlook	Internet Explorer	MS Access
AT1	,443**	,230**	,368**	,294**	,342**	,053
AT2	,368**	,206**	-,317**	-,218**	-,320**	-,066
AT3	-,300**	-,209**	-,270**	-,163**	-,239**	-,118*
AT4	-,243**	,051	-,193**	-,212**	-,284**	,031
AT5	,339**	,090	,279**	,212**	,269**	-,028
AT6	-,370**	-,214**	-,346**	-,226**	-,306**	-,092
AT7	,259**	,120*	,230**	,163**	,258**	-,099*
AT8	,206**	,132**	,201**	,075	,178**	,012
AT9	,170**	,100*	,185**	,096	,126*	,032
AT10	-,102*	-,064	-,105*	-,082	-,099*	-,038
AT11	-,388**	-,241**	-,373**	-,254**	-,338**	-,127*
AT12	,127*	,057	,139**	,072	,160**	,013
AT13	,070	,057	,184**	-,032	-,028	,156**
AT14	,277**	,160**	,281**	,170**	,247**	,078
AT15	-,268**	-,163**	-,240**	-,212**	-,261**	-,052

LEGEND: AT 1- I feel comfortable with the idea of the computer as a tool in teaching and learning, AT 2 - the use of computers in teaching and learning stresses me out, AT 3 - if something goes wrong I will not know how to fix it, AT 4 - the idea of using a computer in teaching and learning makes me skeptical, AT5- the use of the computer as a learning tool excites me, AT6- the use of computers in teaching and learning scares me, AT7 - the computer is a valuable tool for teachers, AT8- the computer will change the way I teach, AT9- the computer will change the way students learn in my classes, AT10- I can do what the computer can do equally as well, AT11- The computer is not conducive to student learning because it is not easy to use, AT12- The computer helps students understand concepts in more effective ways, AT13- The computer helps students learn because it allows them to express their thinking in better and different ways, AT14- The computer helps teachers to teach in more effective ways, AT15- The computer is not conducive to good teaching because it creates technical problems.

The correlation between teachers' attitudes toward the application of ICT in school and the weekly use of common ICT programs is mostly statistically significant and positive, but low. In other words the more teachers use a certain type of ICT programs the more positive attitudes toward the ICT use in school they show and vice versa. The lowest correlation has been found between attitudes toward the use of computers in schools and the use of MS Access.

Table 5. Correlation between the teachers' attitudes toward the use of ICT in school and weekly frequency of specialised ICT programs use regardless of the school subject (N=410)

	FIFA, Solitaire	MS Front Page	MS Publisher	Adobe Photo shop	(Logo, C)	Hyper Studio	Educational CDs	Kidspration, Visio	Modelit, Stella, Electric Work bench	Stagencast Creator, Interactive Physics
AT1	,149**	,095	,123*	,262**	,046	,040	,188**	,054	,061	,042
AT2	-,109*	-,059	-,029	-,163**	-,013	,009	-,152**	-,021	-,004	,003
AT3	-,201**	-,099*	-,122*	-,239**	-,110*	-,032	-,202**	-,091	-,041	-,052
AT4	-,110*	,018	-,018	-,086	,035	,129**	-,128**	,085	,120*	,127**
AT5	,083	-,025	,012	,138**	-,012	-,034	,160**	-,069	-,069	-,007
AT6	-,126*	-,081	-,086	-,224**	-,030	-,026	-,180**	-,068	-,013	,003
AT7	,043	,029	,009	,098*	-,009	-,067	,074	-,127*	-,054	-,052
AT8	,052	,080	,056	,181**	,088	,021	,096	,033	,078	,060
AT9	,053	,084	,068	,175**	,100*	,050	,076	,048	,094	,072
AT10	-,018	-,107*	-,042	-,135**	-,093	-,002	-,070	,022	-,011	,006
AT11	-,188**	-,100*	-,145**	-,204**	-,043	-,038	-,127*	-,109*	-,085	-,050
AT12	,074	,071	,037	,060	,109*	,004	,010	-,003	,019	,016
AT13	,018	,168**	,094	,121*	,197**	,161**	,02511	,140**	,197**	,177**
AT14	,010	,108*	,033	,117*	,137**	,076	,066	,025	,074	,042
AT15	-,156**	-,060	-,055	-,162**	-,063	,048	-,203**	-,002	,096	,062

LEGEND: AT 1- I feel comfortable with the idea of the computer as a tool in teaching and learning, AT 2 - the use of computers in teaching and learning stresses me out, AT 3 - if something goes wrong I will not know how to fix it, AT 4 - the idea of using a computer in teaching and learning makes me skeptical, AT5- the use of the computer as a learning tool excites me, AT6- the use of computers in teaching and learning scares me, AT7 - the computer is a valuable tool for teachers, AT8- the computer will change the way I teach, AT9- the computer will change the way students learn in my classes, AT10- I can do what the computer can do equally as well, AT11- The computer is not

conducive to student learning because it is not easy to use, AT12- The computer helps students understand concepts in more effective ways, AT13- The computer helps students learn because it allows them to express their thinking in better and different ways, AT14- The computer helps teachers to teach in more effective ways, AT15- The computer is not conducive to good teaching because it creates technical problems.

The correlation between teachers' general attitudes toward the use of ICT and the weekly frequency of specialised software use has been shown to be statistically less significant than between general attitudes and common software use. Statistically significant correlations are low to very low and moving in the expected direction: the more often teachers use a certain kind of specialised programs the more positive attitudes toward the ICT use he seems to show and vice versa. Correlation has been found most often between teachers' attitude toward the use of ICT and Photoshop, whereas it has been found less often between attitudes and the use of educational CDs and educational games. The largest number of statistically significant correlations has been found for the following attitude item: *the computer helps students learn because it allows them to express their thinking in better and different ways*.

CONCLUSION

Croatian teachers have mostly positive attitudes toward the use of ICT in schools. Younger teachers and those with shorter work life seem to consider ICT as a valuable tool and that it can positively influence both teachers and pupils. No statistically significant correlation between the attitudes of lower and higher grades teachers, which leads us to the conclusion that all compulsory education teachers in Croatia have similar positive attitudes toward the use of ICT in compulsory education. Weekly frequency of ICT programs use for different school subjects show low correlation with attitudes toward ICT use in a desirable direction (positive attitudes toward the use of ICT). The more often teachers use a certain kind of ICT programs the more positive attitudes toward the use of ICT in school and vice versa. Finally it has been shown that more frequent use of certain kind of specialised ICT programs is connected with more positive attitudes toward the use of ICT in schools, although this tendency is less pronounced with regard to specialised software than with regard to common software.

REFERENCES

1. Albirini, A. A. (2006). Teachers' attitudes toward information and communication technologies: the case of Syrian EFL teachers. *Computers & Education*, 47, 373-398.
2. Al-Zaidiyeen, N.J., Mei, L.L. & Fook, F.S., (2010). Teachers' attitudes and levels of technology use in classrooms: the case of Jordan. *International Education Studies* 3(2)
3. Baylor, A. & Ritchie, D. (2002). What factors facilitate teacher skill, teacher morale, and perceived student learning in technology-using classrooms? *Computers & Education*, 39(1), 395-414.
4. Bullock, D. (2004). Moving from theory to practice: an examination of the factors that preservice teachers encounter as they attempt to gain experience teaching with technology during field placement experiences. *Technology and Teacher Education*, 12(2), 211-237.
5. Chang, S. & Tung, F., (2008). An empirical investigation of students' behavioural intentions to use online learning course websites. *British Journal of Educational Technology* 39(1) 71-83.
6. Compeau, D. R., & Higgins, C. A. (1995). Computer self-efficacy: Development of a measure and initial test. *MIS quarterly*, 19(2).
7. Cox, M., Preston, C. & Cox, K. (1999). *What Factors Support or Prevent Teachers from Using ICT in their Classrooms?* Retrieved on the 18th of February 2014 from: <http://www.leeds.ac.uk/educol/documents/00001304.htm>
8. Delcourt, M. & Kinzie, M. (1993). Computer technologies in teacher education: The measurement of attitudes and self-efficacy. *Journal of Research and Development in Education* 27(1), 35-41.
9. Dogan, M. (2010). Primary trainee teachers' attitudes to and use of computer and technology in mathematics: The case of Turkey. *Educational Research and Review* 5(11), 690-702.
10. Drent, M. & Meelissen, M. (2008). Which factors obstruct or stimulate teacher educators to use ICT innovatively? *Computer & Education* 51, 187-199.
11. Hermans, R., Tondeur, J., van Braak, J. & Valcke, M. (2008). The impact of primary school teachers' educational beliefs on the classroom use of computers. *Computers & Education* 51, 1499-1509.
12. Kersaint, G., Horton, B., Stohl, H., & Garofalo, J. (2003). Technology beliefs and practices of mathematics education faculty. *Journal of Technology and Teacher Education*, 11(4), 549-577.
13. Kiridis, A., Drossos, Y. & Tsakiridou, H. (2006). Teachers facing information and communication technology (ICT): The case of Greece. *Technology and Teacher Education* 14(1), 75-96.
14. Koochang, A. A. (1989). A study of the attitudes toward computers: anxiety, confidence, liking, and perception of usefulness. *Journal of Research on Computing in Education*, 22(2), 137-150.

15. Isleem, M. (2003). Relationships of selected factors and the level of computer use for instructional purposes by technology education teachers in Ohio public schools: a statewide survey. *Doctoral dissertation, the Ohio State University.*
16. Palak, D. & Walls, R. T. (2009). Teachers' beliefs and technology practices: A mixed-methods approach. *Journal of Research on Technology in Education, vol. 41*, pp.157-181.
17. Papanastasiou, E. C & Angeli C. (2008). Evaluating the Use of ICT in Education: Psychometric Properties of the Survey of Factors Affecting teachers Teaching with Technology (SFA-T). *Educational Technology & Society, 11*, 69-86.
18. Papastergiou, M. (2010). Enhancing physical education and sport science students' self-efficacy and attitudes regarding information and communication technologies through a computer literacy course. *Computer & Education 54*, 298–308.
19. Pelgrum, W.J, (1993). Attitudes of school principals and teachers toward computers: Does it matter what they think? *Studies in Educational Evaluation 19*, 199–212.
20. Player –Coro, C. (2012). Factors influencing Teachers' use of ICT in education. *Education Inquiry, Vol.3, No.1*, pp. 93-108.
21. Rogers, E. M. (1995). Diffusion of innovations (4th ed.). New York: The Free Press.
22. Russel, A.L. (1995). Stages in learning new technology: Naive adult email users. *Computers & Education 25*(4), 173–178.
23. Russell, G. & Bradley, G. (1997). Teachers' computer anxiety: implications for professional development. *Education and Information Technologies, Vol.2, No.1*, pp. 17–30.
24. Samak, Z.A. (2006). An exploration of Jordanian English language teachers' attitudes, skills and access as indicator of information and communication technology integration in Jordan. *Doctoral Thesis. Retrieved on the 18th of February 2014 from: http://www.academia.edu/469525/An_Exploration_of_Jordanian_English_Language_Teachers_Attitudes_Skills_and_Access_as_Indicator_of_Information_and_Communication_Technology_ICT_Integration_in*
25. Sang, G., Valcke, M., Braak, J.& Tondeur, J. (2010). Student teachers' thinking processes and ICT integration: Predictors of prospective teaching behaviors with educational technology. *Computers & Education, vol. 54*, pp.103-112.
26. Selwyn, N. (1997). Students' attitudes toward computers: validation of a computer attitude scale for 16–19 education. *Computers & Education, 28*(1), 35–41.
27. Zhao, Y. & Cziko, G. A. (2001). Teachers' adoption of technology: a perceptual control theory perspective. *Journal for Technology and Teacher Education 9* (1), pp. 5-30.

BAZI ELEKTRİK KAVRAMLARI ÜZERİNE SEMİYOTİK YAKLAŞIMIN NASIL KULLANILDIĞINA İLİŞKİN BİR DURUM ÇALIŞMASI

THE CASE STUDY THAT HOW TO USE SEMIOTIC APPROACHES IN SOME CONCEPTS FOR ELECTRICITY

Yaşar Ezgi KARTAL
Gazi Üniversitesi
yezgikartal@gmail.com

Musa SARI
Gazi Üniversitesi
msari@gazi.edu.tr

ÖZET: Bu çalışmanın amacı, fizik öğretmen adaylarının bazı elektrik kavramları konusunda sahip oldukları bilgilerin, kullanılan semiyotik kaynaklar (jest, mimik, söz) üzerindeki yansımalarını belirlemektir. Araştırma, nitel araştırma modellerinden durum çalışmasına örnektir. Çalışma grubu, ölçüt örnekleme yöntemiyle seçilmiş, beş fizik öğretmen adayından oluşmaktadır. Veriler, gözlem ve görüşme kayıtlarıyla toplanmış ve betimsel analize göre değerlendirilmiştir. Araştırma sürecinde, belirtke tablosu oluşturularak on kavram seçilmiş ve araştırmanın geçerlik ve güvenilirliği için gerekli koşullar sağlanmıştır. Araştırma kapsamındaki kamera kayıtları ve gözlem analizlerine göre, öğretmen adayların çoğunlukla vurgu ve işaret jestlerine başvurdukları gözlenmiştir. Yaptıkları metaforik jestlerle ise soyut düşüncelerini açığa çıkarmışlardır. Örneğin, ellerini yuvarlak yaparak yükün küresel olduğunu belirtmişler, pozitif ve negatif yükleri modellerken ise farklı göstergeler kullanmışlardır. Yükü fazla olan cisimi, az olana göre daha yukarıda tutarak sayı doğrusunun artan yönüne göre modelleme yapmışlardır. Araştırmada, konuşmalara eşlik eden semiyotik kaynakların anlam oluşturma ve düşünceyi aktarma sürecinin önemli bir unsuru olduğu gözlenmiştir. Çalışmanın analiz süreci devam etmektedir.

Anahtar sözcükler: fizik, eğitim, semiyotik, jest, elektrik

ABSTRACT: The aim of this study, prospective physics teachers who use semiotics resources determine in physics education how to use this approach. The method of this study is qualitative research. The study group selected by the Criteria Sampling Method, consists of five prospective physics teachers. The data gathered through observation and interview records and datas was evaluated according to descriptive analysis. In the research process, ten concepts was chosen with creating a table of specifications. Analysis according to the camera records, observations, deictic and beat gestures has been observed mostly by the prospective physics teachers. Metaphoric gestures have revealed the thoughts which is abstract. For example, they have said that electric charges have spherical shape. When modelling positive and negative charges, they use different indicators. In this study, we observed that gesture is an important element of the process of creating the meaning. The study is continuing the process of analysis.

Key words: physics, education, semiotic, gesture, electricity

GİRİŞ

Sözel göstergelerin kullanımı semiyotiğin sadece bir dalıdır. Bu anlamda semiyotik, sözsüz iletişimi içine alan daha genel bir kavramdır. Göstergeler, kelimeler, resimler, grafikler, beden dili, trafik işaretleri vb. ni içerir. Jestlerin, semiyotik anlamda önemi çok büyüktür. Çünkü beden dilinin çoğunluğunu jestler oluşturur. Bu nedenle jestleri, sözsüz göstergeler başlığı altına alabiliriz.

Kendon'a göre sözel olmayan iletişimin bir parçası olan jestler konuşmanın kendisinden ayrı tutulamazlar (Kendon, 2000). McNeill jestleri insanlar konuştukları zaman ortaya çıkan el kol hareketleri olarak tanımlamıştır (McNeill, 1992, s. 1). Bu yaklaşımda jestler konuşmadan ayrı olarak görülmüştür ama konuşma diliyle ilişkilendirilmiştir. Bu tanım çok geniş kapsamlı bir tanımdır. Hangi tanım alınırsa alınsın jestler biraz belirsiz bir kavramdır ve neyin jest olduğu ve neyin jest olmadığı arasında kesin bir çizgi yoktur.

Fizik öğrenme ortamlarında jestler el ve kolların hareketi olarak görülebilir ama bu hareketler, yazı yazmak, bir araç kullanmak gibi bir eylemin parçaları olmaktan ziyade öğretmenin ve öğrencilerin fiziksel etkinliklerde kullandıkları hareketler olmalıdır.

Son zamanlarda çeşitli araştırmalar jestlerin sadece iletişimde önemli olmadığını aynı zamanda bilişsel olarak da önemli olduğunu göstermektedirler. Yine Sabena (2008) bir çalışmasında, Vygotsky'nin (1934/1986, s.218) düşünce sadece kelimelerle ifade edilmez, onlarla var olur varsayımıyla paralel olarak McNeill'in (1992) jestlerin düşünceyi sadece yansıtmadıklarını aynı zamanda düşüncenin üzerinde etkiye sahip olduklarını belirttiğini ifade etmiştir.

McNeill (1992) jestleri, dört başlık altında toplamıştır. Bunlar; ikonik, metaforik, işaret ve vurgu jestleridir.

İkonik Jestler (Iconic Gestures)

Konuşmanın anlamsal içeriği ile benzer nitelik taşır.

Metaforik Jestler (Metaphoric Gestures)

Ekman ve Friesen'e (1969) göre metaforik jestler ikonik jestlere benzerdirler yalnız metaforik jestler resimseldirler. Fakat burada resimsel içerik somut bir nesne veya hareketten ziyade bir fikri sunar. O halde metaforik bir jest soyut bir kavramın görselleştirilmesini içerir.

İşaret Jestleri (Deictic Gesture)

Bu jestler işaretleme jestleridir. Somut dünyadaki olayları, nesnelere, yerleri gösterir (Radford, Schubring ve Seeger, 2008). İşaret jestleri bedeninin bütün uzuvlarıyla gerçekleştirilebilmesine rağmen genellikle işaret parmağı kullanılmaktadır. Bu durumda gerçekte işaret edilen bir nesne yoktur.

Sabena (2008), matematik eğitiminde jestler üzerine yaptığı çalışmasında McNeill'in bunu şu şekilde ifade ettiğini söyler:

“Konuşmacı bir boşluğu işaret eder ama aslında o boşluk boş değildir. Önemli kavramlarla doludur. Bu tip soyut gösterimler, kavramların soyut olarak verildiği boşluğun kullanımını vurgular.” (McNeill, 1992, s. 173).

Vurgu Jestleri (Beat Gesture)

Konuşmanın etkisi ile ellerin hareket etmesidir. Konuşmacı jسته eşlik eden cümle veya kelimeye vurgu yapar.

Bir jest birden fazla anlam taşıyabilir. İki jest birlikte kullanılmasıyla daha büyük kompleks hiyerarşik olarak daha ileri bir anlam oluşturmazlar ama dilde bu olur.

Bu bilgilerden hareketle, öğrenme ortamında öğrencilerin bir fiziksel kavramı anlatırken kullandıkları jestlerden anlatmak istedikleri kavram hakkındaki düşüncelerini anlamak mümkündür. Konuşma esnasında yapılan jestlerden, o kavram hakkındaki yanlış anlamaları, kavram kargaşaları ve hatta ayrıntılı görüşmelerle kavram yanlışları ortaya çıkarılabilir. Fizik eğitiminde semiyotik uygulamasının araştırmacılar, öğretmenler ve öğrenciler arasında ortak, farklı ve "SOMUT" bir dil oluşturmaya yardımcı olabileceği de önerilmektedir (Pantidos, Valakas, Vitoratos ve Ravanis, 2008).

Yapılan literatür taramasında, özellikle matematik eğitiminde semiyotik perspektifin kullanıldığı görülmüştür. Ancak Türkiye'de fizik eğitiminde bu içerikte yapılmış bir çalışmaya rastlanmamıştır. Bu alanda yapılan çalışmaların az sayıda olması, semiyotik konusunda çalışma yapılmasını gerekli kılmaktadır.

Bu çerçevede araştırmanın ana hedefi, fizik eğitiminde semiyotik yaklaşımın nasıl kullanıldığını belirlemektir. Bu hedef doğrultusunda, öğrencilerin kullandığı jestlerin McNeill'in sınıflandırmasına göre hangi jest grubuna girdiği belirlenmeye çalışılmış ve kullanılan jestlerin analizi yapılmaya çalışılmıştır.

Bu araştırmanın en temel amacı, fizik öğretmen adaylarının bazı elektrik kavramları konusunda sahip oldukları bilgilerin, öğretmen adaylarının kullandıkları semiyotik kaynaklar üzerindeki yansımalarını belirlemektir. . Bu kapsamda, öğretmen adaylarının bazı temel kavramları semiyotik kaynaklarla ilişkilendirerek nasıl açıkladıkları,

sıklıkla kullanılan semiyotik kaynakların neler olduğu, kullandıkları jestlerin McNeill'in sınıflandırmasına göre hangi jest grubuna girdiği incelenmiştir.

YÖNTEM

Araştırmanın Modeli

Araştırma, nitel araştırma modellerinden durum (örnek olay) çalışmasına örnektir. Durum çalışmaları, bilimsel sorulara cevap aramada kullanılan ayırt edici bir yaklaşım olarak görülmektedir. McMillan (2000), durum çalışmalarını bir ya da daha fazla olayın, ortamın, programın, sosyal grubun ya da diğer birbirine bağlı sistemlerin derinlemesine incelendiği yöntem olarak tanımlamaktadır.

Araştırmalarda durum çalışmaları, a) bir olayı meydana getiren ayrıntıları tanımlamak ve görmek, b) bir olaya ilişkin olası açıklamaları geliştirmek, c) bir olayı değerlendirmek amacı ile kullanılır (Gall, Borg ve Gall, 1996). Bu yüzden bu modelin çalışmaya en uygun model olduğu düşünülmektedir.

Çalışma Grubu

Çalışma grubu, Gazi Üniversitesi Gazi Eğitim Fakültesi'nde öğrenim gören ve temel elektrik dersini almış beş fizik öğretmen adayından oluşturulmuştur. Tüm adaylar; A1, A2, A3, A4, A5 olarak kodlanmıştır.

Veri Toplama Araçları

Görüşmeler başlamadan önce, temel elektrik konuları ile ilgili bir belirtke tablosu hazırlanmıştır. Araştırmaya dahil edilecek kavramlar için belirtke tablosunda yer verilen kriterler; kavramın öğrenciler için kolay anlaşılabilir olması, kavramların soyut olması, kavramların somutlaştırılacak göstergeler kullanmaya elverişli olması ve aynı kavramın farklı göstergelerle ifade edilmesidir.

Araştırma sürecinde belirlenen kriterlere göre on kavram seçilmiş ve araştırmanın geçerlik ve güvenilirliği için gerekli koşullar sağlanmıştır. Seçilen kavramlar; elektrik yüklerinin özellikleri, statik elektrik, iletken ve yalıtkanlar, elektrik alan ve elektrik alan çizgileri, elektriksel potansiyel ve potansiyel fark, voltmetre, elektromotor kuvveti, elektrik akımı ve ampermetre, direnç, kondansatör ve sığa'dır.

Bu çalışmada kullanılan veri toplama araçları, kamera kayıtları ve gözlemlerdir. Fizik öğretmen adaylarının temel elektrik konularında sahip oldukları bilgileri, hangi semiyotik kaynaklar ile ifade ettiğini tespit edebilmek için kamera kayıtları kullanılmıştır. Beş fizik öğretmen adayı ile ayrı ayrı yapılan görüşmeler kayıt altına alınmıştır.

Verilerin Toplanması

Veriler, gözlem ve kamera kayıtları ile toplanmıştır. Araştırma, yüksek lisans tez çalışması kapsamındadır. Görüşmelere yeni başlanmıştır ve sadece elektrik yükleri ve statik elektrik kavramları ile ilgili görüşmeler yapılabilmektedir. Araştırmanın uygulama ve analiz süreçleri devam etmektedir.

Verilerin Çözümlemesi ve Yorumlanması

Veriler, uzman yardımı olarak araştırmacı tarafından, betimsel analiz yapılarak çözümlenmiştir.

Kamera kayıtlarında dikkat ettiğimiz nokta, fizik öğretmen adaylarının bazı elektrik kavramları konusunda sahip oldukları bilgileri, uygun semiyotik kaynaklar ile ifade edip edemediğidir. Görüşme sırasında, kullandıkları semiyotik kaynağa bağlı olarak sorulan ek sorularla, fizik öğretmen adaylarının hangi noktalarda doğru hangi noktalarda yanlış düşündükleri belirlenmeye çalışılmıştır.

Çalışmamız nitel bir çalışma olduğundan, doğrudan bir genelleme yapmak mümkün olmayacaktır. Bu nedenle, sonuçların ne ölçüde genellenebileceğine dair yorumlar yapılacaktır. Analizler, ham verilerin bir uzman tarafından incelenmesi ile teyit edilecektir.

BULGULAR

Yapılan kamera kayıtları ve gözlem analizlerine göre, öğretmen adayların çoğunlukla vurgu ve işaret jestlerine başvurdukları gözlenmiştir. Yaptıkları metaforik jestlerle ise soyut düşüncelerini açığa çıkarmışlardır. Aşağıda, kamera kayıtlarından iki alıntıya yer verilmiştir.

Araştırmacı: Yük denildiği zaman zihninizde oluşan yapıyı tanımlayabilir misiniz?

A1: Hocam, yük böyle noktasal değil mi? Yani, aklıma direk bir nokta geliyor.

Araştırmacı: Noktasal derken çok küçük olduğunu belirtmek için mi noktasal diyorsun yoksa başka bir sebebi mi var?

A1: Genelde daire, çember en mükemmel şekil oluyor ya, yük ve atom en mükemmel yakın şekillerdir, aklıma hep öyle geliyor.

A1 ile kodlanmış fizik öğretmen adayı, yükü tanımlarken yükün noktasal olduğunu söylemiş ve bir taraftan da işaret parmağı ile havaya bir nokta koymuştur. En mükemmel şekle sahip olduğu için yükün küresel olması gerektiğini belirtmiştir. Bu konuşmaya, işaret ve metaforik jestler eşlik etmiştir. İncelenen kayıtlara göre, diğer öğretmen adaylarının da yük algısının küresel olduğu sonucuna varılmıştır.

Araştırmacı: Sizin de söylediğiniz gibi iki çeşit elektrik yükü bulunmaktadır. Pozitif ve negatif. Bir şeyin pozitif veya negatif yüklü olması hakkındaki algınız nedir?

A2: Ya mesela benim aklıma şey deneyi geliyor. Bir altın plakaya alfa parçacığı gönderiliyor. Hani orda sapma miktarına bakarak pozitif mi negatif mi olduğu belirleniyor.

Araştırmacı: Yani ikisi farklı mıdır? Pozitif ve negatif yükü somutlaştırabilir misin?

A2: Bu pozitif bu negatif.

Araştırmacı: Negatife pozitif diyemez miydik?

A2: O zaman pozitif de negatif derdik.

Pozitif ve negatif yükler modellenirken farklı göstergeler kullanılmıştır. A2 ile kodlanan fizik öğretmen adayı, elleriyle iki yuvarlak oluşturmuştur. Pozitif yükü gösterirken sol bileği yukarı bakarken, negatif yükü gösterirken sağ bileği aşağıya yönelmiştir. Sözlerine, metaforik jestler eşlik etmiştir. Ayrıca, konuşması boyunca, elleriyle vurgu jestleri yapmıştır. Pozitif ve negatif isimlendirmesinin de bir kabulden ibaret olduğunu belirtmiştir.

Ayrıca, yükü fazla olan cismi, az olana göre daha yukarıda tutarak sayı doğrusunun artan yönüne göre modelleme yapmışlardır.

Araştırmada, konuşmalara eşlik eden jestlerin anlam oluşturma ve düşünceyi aktarma sürecinin önemli bir unsuru olduğu gözlenmiştir.

SONUÇ

Bu araştırmada, Gazi Üniversitesi Gazi Eğitim Fakültesi'nde öğrenim gören ve elektrik ve manyetizma dersini almış beş fizik öğretmen adayı ile bazı elektrik kavramları ile ilgili çalışmalar yapılmıştır. Bu çalışmada, elektrik yüklerinin özellikleri, statik elektrik, iletken ve yalıtkanlar, elektrik alan ve elektrik alan çizgileri, elektriksel potansiyel ve potansiyel fark, voltmetre, elektromotor kuvveti, elektrik akımı ve ampermetre, direnç, kondansatör ve sığa kavramlarının analizi yapılarak araştırma sorularına cevap aranmıştır.

Görüşmeler, kamera ile kayıt altına alınmıştır. Fizik öğretmen adaylarının bu temel kavramları semiyotik kaynaklarla ilişkilendirerek nasıl açıkladıkları, sıklıkla kullanılan semiyotik kaynakların neler olduğu incelenmiş, kullandıkları jestler McNeill' in sınıflandırmasına göre sınıflandırılmaya çalışılmıştır.

Fizik öğretmen adaylarının görüşlerini belirtirken jestler yaptıkları ve bu jestlerin düşüncelerinin oluşumuna ve düşüncelerini ifade etmelerine yardımcı olduğu gözlenmiştir. Öğretmen adaylarının sıklıkla kullandığı jestler,

işaret ve vurgu jestleri olmuştur. Kavramları açıklarken, sözle ifade edemediği bazı durumları anlatırken vurgu jestleri ön plana çıkmıştır.

Zihinlerindeki soyut kavramları somutlaştırırken metaforik jestleri kullanmışlardır. Örneğin, ellerini yuvarlak yaparak yükün küresel olduğunu belirtmişler, pozitif ve negatif yükleri modellerken ise ikisi için farklı göstergeler kullanarak ikisinin farklı olduğunu anlatmışlardır. Yükü fazla olan cismi az olana göre daha yukarıda tutarak sayı doğrusunun artan yönüne göre modelleme yapmışlardır. Konuşmalara eşlik eden jestlerin anlam oluşturma ve düşünceleri aktarma sürecinin önemli bir unsuru olduğu gözlenmiştir.

ÖNERİLER

Fizikteki diğer kavramlarla ilgili ortaya çıkan jestler tespit edilebilir.

Çalışma daha geniş öğrenci kitlesine uygulanabilir.

Sadece öğrencilerin değil öğretmenlerin de sürece katıldığı bir çalışma yapılabilir.

Çalışma, daha da geliştirilerek öğretmen-öğrenci arasında ortak bir dil geliştirilebilir. Öğrencilerin kavramlara ait yaptıkları jestler sınıflandırılarak çoğunluğun tercih ettiği jest ile o kavram eşleştirilebilir.

KAYNAKLAR

- Akerson, F. (2005). *Göstergebilime Giriş*. İstanbul: Multilingual Yabancı Dil Yayınları.
- Altıntaş, E. ve Çamur, D. (2005). *Beden dili: Sözsüz İletişim*. İstanbul: Alfa Aktüel Yayınları.
- Bakker, A., Hoffmann, M. H. G. (2005). Diagrammatic reasoning as the basis for developing concepts: a semiotic analysis of students' learning about statistical distribution. *Educational Studies in Mathematics*, 60, 333–358.
- Büyüköztürk, Ş. (2012). *Bilimsel araştırma yöntemleri*. Ankara: Pegem Akademi
- Karasar, N. (1982). *Bilimsel araştırma yöntemi: Kavramlar, ilkeler, teknikler*. Ankara: Nobel Yayınları.
- Kendon, A. (1982). The study of gesture: Some observations on its history. *Recherches Sémiotiques/Semiotic Inquiry*, 2(1), 45–62.
- Kendon, A. (1996). An agenda for gesture studies. *Semiotic Review of Books*, 7(3), 8–22.
- McNeill, D. (1992). *Hand and Mind: What Gestures Reveal about Thought*. Chicago: University of Chicago Press.
- Pantidos, P., Valakas, K., Vitoratos, E. ve Ravanis, K. (2008). Towards applied semiotics: An analysis of iconic gestural sign regarding physics teaching in the light of theatre semiotics. *Journal of the International Association for Semiotic Studies*, Semiotica 172-1/4, 201-231.
- Radford, L., Schubring, G. ve Seeger, F. (2008). *Semiotics in Mathematics Education: Epistemology, History, Classroom and Culture*. Sayı 1, 19-38.
- Schubring, G. (2011). Conceptions for relating the evolution of mathematical concepts to mathematics learning—epistemology, history, and semiotics interacting. *Educational Studies in Mathematics*, 77, 79–104.

ÖĞRETMEN ADAYLARININ ÖĞRETİM TEKNOLOJİLERİ VE MATERYAL TASARIMI DERSİNE YÖNELİK TUTUMLARI İLE ÖĞRETMEN ÖZ-YETERLİLİKLERİ ARASINDAKİ İLİŞKİNİN ANALİZİ

Vural TUNKLER

Alıye Nur ERCAN

Mehmet BESKIRLI

Ismail SAHİN

Bu araştırmanın amacı, öğretmen adaylarının öğretim teknolojileri ve materyal tasarımı (ÖTMT) dersine yönelik tutumlarını ortaya koymak ve bu tutumları ile öğretmen öz-yeterlilik algıları arasındaki ilişkiyi incelemektir. Araştırma betimsel türde tarama modeline göre yapılacaktır. Araştırmanın çalışma grubunu, öğretim teknolojileri ve materyal tasarımı dersini almış olan öğretmen adayları oluşturacaktır. Verilerin toplanması sürecinde Çapa vd. (2005) tarafından Türkçe'ye uyarlanan "Öğretmen Öz-Yeterlilik Ölçeği" ile Çetin vd. (2013) tarafından geçerlik ve güvenilirlik çalışması yapılan "Öğretim Teknolojileri ve Materyal Tasarımı Dersine Yönelik Tutum Ölçeği" kullanılacaktır.

Anahtar Kelimeler: Öğretmen adayları, ÖTMT dersi, tutum, öz-yeterlilik

oooooooooooooooo

ÖĞRETMEN ADAYLARININ ÖĞRETİM TEKNOLOJİLERİ VE MATERYAL TASARIMI DERSİNE YÖNELİK TUTUMLARI İLE ÖĞRETMEN ÖZ-YETERLİLİKLERİ ARASINDAKİ İLİŞKİNİN ANALİZİ

Vural TUNKLER

Alıye Nur ERCAN

Mehmet BESKIRLI

Ismail SAHİN

The purpose of this study is to reveal the attitudes of teacher candidates towards instructional technologies and material design (ITMD) course and to examine the relationship between their attitudes and teacher self-efficacies perceptions. The study will be based on descriptive scanning model. The sample of the study consists of all teacher candidates that received instructional technologies and material design course. In the collection of data, "Teacher Self-Efficacy Scale" adapted by Çapa et al. (2005) into Turkish and "Attitudes Towards Instructional Technologies And Material Development Course Scale" developed by Çetin et al (2013) will be used.

Keywords: Teacher Candidates, ITMD course, attitude, self-efficacy

ÖĞRETMENLERİN CİNSEL SAĞLIK BİLGİ DÜZEYLERİ

SEXUAL HEALTH KNOWLEDGE LEVEL OF TEACHERS

Sinan ERTEN
Hacettepe Üniversitesi
serten@hacettepe.edu.tr

İrem AKÇAM YALÇIN
Hacettepe Üniversitesi
iakcam@hacettepe.edu.tr

ÖZET: Bu araştırmanın temel amacı, öğretmenlerin cinsel sağlık bilgi düzeylerini belirlemektir. Araştırmaya Türkiye’ de görev yapmakta olan 462 ilkokul, ortaokul ve lise öğretmeni katılmıştır. Araştırma, mevcut olan durumu saptamaya yönelik olduğundan ilişkisel tarama modelinde bir çalışma olarak yürütülmüştür.

Araştırma kapsamında ölçeğin güvenilirliğini belirlemek için cronbach alfa korelasyon katsayısı hesaplanmış ve 0,782 olarak bulunmuştur. Katılımcıların kişisel özelliklerine ilişkin bulgular yüzde ve sıklık istatistikleri ile çözümlenmiştir. Verilerin analizinde t-testi ve ANOVA kullanılmıştır 5’li likert tipi “Cinsel Sağlık Bilgisi” ölçeğinden alınabilecek puanlar 1 ile 5 arasındadır.

Öğretmenlerin cinsel sağlık bilgisi düzeylerinin yüksek olduğu söylenebilir. Ayrıca yapılan analizler sonucunda kadın öğretmenlerin erkek öğretmenlerden, evli öğretmenlerin bekar öğretmenlerden, lisansta cinsel sağlık bilgisi dersi alanların almayanlardan ve cinsel sağlık eğitimi alanların almayanlardan cinsel sağlık bilgisi düzeylerinin anlamlı derecede daha yüksek olduğu bulunmuştur.

Anahtar sözcükler: Cinsel sağlık, cinsel sağlık bilgisi, öğretmen

ABSTRACT: The aim of this study is to examine the level of sexual health knowledge of teachers. The sample of the study is constituted of 462 teachers working at primary, secondary and high schools in Turkey. As the study is oriented at determining the current status, it was conducted as a relational screening model study.

The cronbach alpha correlation coefficient was calculated and determined to be 0.782. Findings regarding the personal details of the participants were analyzed with percentile and frequency statistics. In the analysis of data, t-test and ANOVA was used. The points that can be obtained from the 5 point likert “Sexual Health Knowledge” scale are between 1 and 5.

It can be observed that teachers have a high level of sexual health knowledge. It can be observed that the levels of sexual health knowledge of female teachers are significantly higher than those of male teachers. It can be observed that the levels of sexual health knowledge of married teachers are significantly higher than those of single teachers. It can be observed that the levels of sexual health knowledge of teachers that had sexual health lesson at university are significantly higher than those of other teachers. It can be observed that the levels of sexual health knowledge of teachers that had sexual health training are significantly higher than those of other teachers.

Key words: Sexual health, sexual health knowledge, teacher

TÜRKİYE VE ÇİN-TAYVAN 8. SINIF DÜZEYİ MATEMATİK ÖĞRETİM PROGRAMLARININ VE TIMSS SONUÇLARININ KARŞILAŞTIRILMASI

A COMPARISON OF TURKISH AND CHINESE TAIPEI 8th GRADE MATHEMATICS CURRICULUMS AND TIMSS RESULTS

Kürşat YENİLMEZ
Eskişehir Osmangazi Üniversitesi Eğitim Fakültesi
kyenilmez@ogu.edu.tr

Şule KOÇYİĞİT
Milli Eğitim Bakanlığı
sulekesgin@gmail.com

ÖZET: Karşılaştırmalı eğitim genel olarak ülkelerin eğitim sistemleri hakkında fikir vermekle beraber eğitim programlarının geliştirilmesi ve uygulamada yaşanan bazı sorunlar, eğitim yönetimi, öğretmen yetiştirme gibi pek çok özel alanlarda dünyada ne gibi gelişmeler yaşandığı ve sorunlara ne gibi çözümler bulunduğu hakkında da fikir verebilmektedir. Bu kapsamda eğitim sistemlerinin diğer eğitim sistemleri ile karşılaştırılması çalışmaları artmaktadır. Özellikle son zamanlarda uluslararası sınavlarda (TIMSS, PISA) matematik açısından pek çok gelişmiş ülkeyi geride bırakarak ilk sıralara yerleşen Doğu Asya ülkelerinin matematik eğitimleri dikkat çekmektedir. Bu doğrultuda bu araştırma son zamanlarda TIMSS ve PISA gibi uluslararası düzeyde ülkelerin matematik başarılarını ölçen sınavlarda üst sıralamalarda yer alan Çin-Tayvan ve bu sınavlarda ortalamanın altında yer alan ülkemizin 8.sınıf düzeyi matematik öğretim programlarını çeşitli değişkenler açısından karşılaştırmayı ve ülkemizde yapılacak olan program geliştirme çalışmalarına katkı sağlamayı amaçlamaktadır. Türkiye ile Çin-Tayvan ülkelerinin 8. sınıf düzeyinde matematik öğretim programları içerik, genel amaçları ve felsefeleri, öğrenme alanları, haftalık matematik ders süreleri karşılaştırılarak benzerlik ve farklılıklara ve TIMSS 2011 matematik sonuçlarına yer verilmiştir. Yöntem olarak araştırma nitel bir çalışma olup araştırma yaklaşımı ise karşılaştırmalı eğitim yaklaşımlarından yatay yaklaşımdır. Araştırmada kullanılan veriler (öğretim programları) Türkiye için Talim Terbiye Kurulu'nun resmi internet sitesinden (MEB, 2013) elde edilirken Çin-Tayvan matematik programı APEC (Asya Pasifik Ekonomik İşbirliği) internet sitesinden elde edilmiştir. Araştırma verileri doküman analizi yöntemiyle analiz edilmiştir.

Anahtar sözcükler: Matematik Öğretim Programı, Karşılaştırmalı Eğitim, Eğitim Programları

ABSTRACT: Comparative education gives an idea not only about education systems of the countries but also about the developments and solutions to the problems in the World like processes of the curriculum development and some problems in practice, educational administration, teacher education. In this context, studies about the comparisons of educational systems is increasing. Especially recently, Mathematics education systems of eastern asian countries which outdistanced most of other developed countries in international exams (TIMSS, PISA) are standing out. This study aims to compare the eighth grade mathematics curriculums of recently high ranking Chinese-Taipei and our country which is under average in international exams measuring mathematics achievement of countries like TIMSS and PISA; and to contribute to the future curriculum development studies in our country. 8th grade mathematics curriculums of Turkey and Chinese-Taipei were compared in terms of content, general purpose and philosophies, learning areas, weekly lesson times and similarities and differences and TIMSS 2011 mathematics results were given. The study is a qualitative study and horizontal approach of comparative education approaches was used. The data was gained from Talim Terbiye Kurulu (MEB, 2013) and APEC (Asia Pasific Economic Cooperation) websites. The data was analysed using document analysis.

Key words: Mathematics Curriculum, Comparative Education, Curriculums.

IMPACTS OF ERGONOMICS ON SUDANESE HIGHER EDUCATION INSTITUTIONS ICT CLASS ROOMS

Nour Eldin Mohamed ELSHAIEKH
Assistant Professor, Dean Faculty of Computer Science
Future University, PO Box 10553, Khartoum, Sudan
Tel: +249915143666, email: noreldine@hotmail.com, nour@fusudan.net

Mazin Ahmed Mohamed BILAIL
Lecturer, Faculty of Information Technology
Future University, PO Box 10553, Khartoum, Sudan
Tel: +249916661667, email: mazin_b@hotmail.com

ABSTRACT: Ergonomic computer field is the science concerned with conniving safe and comfortable situations for the users of information and communication technology equipment's. In the computer field, ergonomics plays very important factor in the design of all computer equipment's, therefore in Sudanese higher education Institutions (HEI) ICT class rooms will be affected directly with how the equipment's will be arranged and the environments itself.

Due to the current situation of ICT class rooms, Sudanese higher education Institutions were facing problems in the learning activities as most of these class rooms were not equipped and arranged properly using ergonomic steps and processes due to the lack of perception of the importance of the ergonomics.

Research paper will focus on the impact of Ergonomics on Sudanese higher education Institutions ICT class. The researcher collected data from Different universities in Sudanese HEI. The research questionnaires will be analyzed using SPSS. Descriptive Statistics and the distribution of respondents and percentage of responses to the questions in the questionnaire analysis will be presented to find the results.

The Results of the paper will be presented based on the basic ergonomics roles and including the main issues of the ergonomics, which will help these institutions to improve the ICT class rooms and teaching accessibility, Support students /teacher to adopt better pedagogical and provide over all cognizance of the general knowledge.

Keywords: Knowledge management; Ergonomics; Sudanese Higher Education institutions, information and communication Technologies, ICT class Room.

1. INTRODUCTION

This paper will discuss how the ergonomic will affect on Sudanese higher education Institutions ICT class rooms. The paper contains useful information and ideas about the importance of computer ergonomics from the students' academic achievements specifically information and communication technology equipment's Adjustment in the learning class rooms.

2. BACKGROUND

This part will contain the definition of paper keywords and including the

3. Literature Review

This section provides a review of the basic literature which will help to design the contexts of the study paper. The review for the study includes Ergonomics; Sudanese Higher Education institutions, information and communication Technologies, ICT class Room.

3.1. Ergonomics

The science of fitting the work situation, work demands and work practices to the competences of the working people to keep safety, efficiency and excellence of work”
Ergonomics at Work Inc., 2002.

Ergonomics relates information about human behavior, aptitudes and boundaries and other features to the design of computer tools, machines, accessories, jobs and environments for creative, safe, comfortable and actual human use” (McCormick and Sanders, 1992).

3.2. Sudanese Higher Education

Education is a basic human right, so the revolution of higher education in Sudan is going on the same linear specifically. Incredibly, there have been more than ninety colleges and universities in Sudan, 70% are public and 30% are private, most of these universities they are use the ICT tools in the learning activities. Nowadays, KBS make extensive use of ICT, especially the knowledge base and Internet because of its potential in advancing interactivity between users.

3.3. Information and communication Technologies

Information and Communication Technology (ICT) is a large umbrella term that contains all the practical equipment to procedure and communicate information. ICT contains two features of information technology and communication technology. Information technology includes all materials relating to the processing, usage as instrument, operation, and organization of information (AGDE, 2010).

3.4. ICT Class room

According to Cox, Preston & Cox (1999) the use of ICT in classrooms include: Making educations more interesting, more pleasant for teachers and students, more varied, more inspiring, and Helpful of productive learning. General, it is strong that the emotional factors of a teacher's will facilitate and barriers to teacher use of technology in the classroom. Those facilitators will make successful ICT classroom.

3.5. Computer Ergonomic Issues

As mentioned by DBCVSRI, Health & Safety Coordinator Leslie Steinberg (40329) and Anderson (1997) Adjusting the workstation to best appropriate of staff/students in education actives will include the following items: Workstation Design(desks, chairs, space, layout), Work Postures (sitting, standing, reaching, lifting), Work Organization (Pace, Breaks, Variety), Tools, Equipment, and Furniture Design (body size, height, gender, promoting neutral postures, reduced vibration, exposure to acceptable lighting, noise, temperature), Manual Materials Handling (lifting, lowering, pulling, pushing, carrying and holding materials), Work Environment (ventilation, noise, temperature & humidity, lighting and vision).

3.6. The Problem

Although the growing use of ICT tools in Sudanese HEI still they did not gain the full effective and advantages of using ICT in the education activities, this could it be a reflection of the less acknowledgement of the role of ergonomic in the applying and designing ICT tools and equipment's in the classrooms. Based on the problem raised the following research question is posed:

How the computer ergonomic will effect on Sudanese higher education Institutions ICT class rooms?

3.7. Research Model

The following research model (Figure 1) was developed based on the Computer Ergonomic Issues identified in the literature in order to assist this study in answering the above questions.

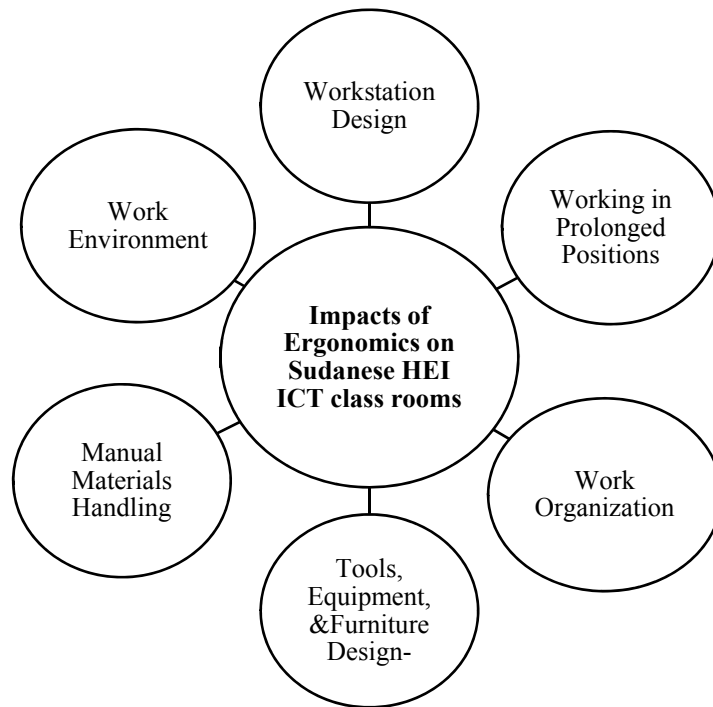

Figure 1: Computer Ergonomics Issues in Sudanese HEI ICT classrooms

4. METHODOLOGY AND SAMPLING

Descriptive statistics techniques was be used to analyze the data. The questionnaire technique of data collection was used. A multiple Sudanese Universities/ Colleges purposively selected as participant of the questionnaire. The selection of these participants was based on their specialization. Statistical Package for the Social Sciences (SPSS) used to answer the research question.

There are approximately 97 university / College in Sudan with a target population of approximately 650,000 students and 21000 academic staff.

Even though 300 questionnaires were distributed to the participants, only 95 (31.7%) questionnaires were not returned. Only 161 (53.7%) copies were completely answered. The remaining of 44 (14.7%) questionnaires could not be included in the study due to incomplete data or poor responses (see Figure 2).

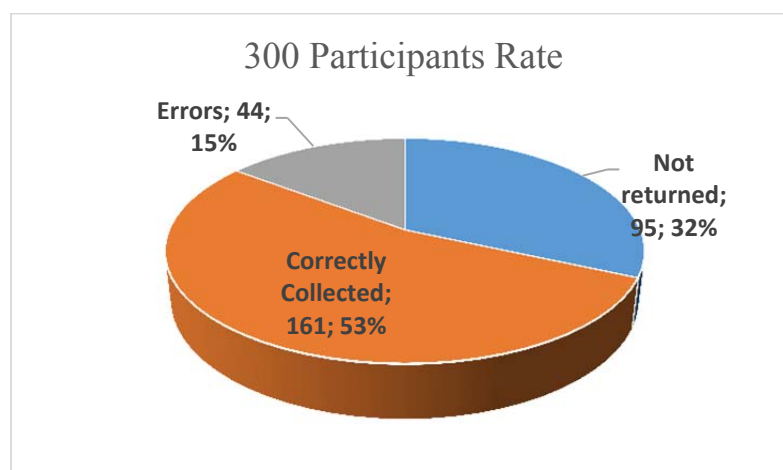

Figure 2: Staff/Students Response Rate

5. DATA ANALYSIS AND RESULT

Quantitative approach was used to answer the question about the Impacts of Ergonomics on Sudanese higher education Institutions ICT class rooms from the participants' point of view. This will include data has been collected from multiple Sudanese Universities/ Colleges to select the participants of the questionnaire. Table 1 mentioned the repose of the participant.

Table 1: The Participants Feedback

Ergonomic Issue	Ergonomic tips	Applied	Not Applied	Feedback
Workstation Design	Desks	19%	81%	Negative on impact tools or equipment
	Chairs	12%	88%	Affect with stiffness or cramping
	Space	32%	68%	Nose and stress
	Layout	13%	87%	Negative affect with Compression or contact stress
Working in Prolonged Positions Sitting/Standing-	Postures	25%	75%	Body pain
	Footwear	0%	100%	Foot and back pain and Bending
	Floors	66%	34%	Affect negatively with Nose
Work Organization	Pace	8%	92%	Compression or contact stress
	Breaks	16%	84%	Affect with Forceful exertions
	Variety	12%	88%	Out of mode and understanding
Tools, Equipment, and Furniture Design-	Body	10%	90%	Body Pain, numbness & tingling
	Gender	0%	100%	Female Awkward postures
	Postures	19%	81%	Static or sustained postures
	Vibration	12%	88%	Damage of equipment's and stress for users
	Lighting	9%	81%	Forceful exertions and Stress
	Noise	13%	87%	Compression or contact stress
	Temperature	15%	85%	Uncomfortably, Stress
	Lifting	5%	95%	Compression or contact stress
Manual Materials Handling	Pulling	7%	93%	Compression or contact stress
	Pushing	10%	90%	Compression or contact stress
	Holding Materials	2%	98%	Compression or contact stress
	Ventilation	50%	50%	Very bad health environment
Work Environment	Noise	10%	90%	Inconvenience and stress
	Humidity	60%	40%	Pain and shortness of breath
	Lighting & Vision	45%	55%	Eye strain

6. DISCUSSION CONCLUSION

The computer ergonomic offer very influential procedures to higher education institution classrooms in the Sudan. However, Ergonomics is important because it makes staff/student be in better health environments and be more effective as they work in enjoyable environments. Ergonomics usually recovers productivity in learning area as has been stated in several of the studies reviewed. This research paper explore the Impacts of Ergonomics on Sudanese higher education Institutions ICT class rooms

The analysis and findings of the results obtained from the data that were generated through the distribution of questionnaires are presented in this paper.

Of the overall computer ergonomic issues the analysis show firstly that the Manual Materials Handling is the less issues with average percentage of (6 to 94), that Sudanese HEI were caring when they design the ICT classrooms and techniques, therefore this will affect negatively in compression or contact environment of students /staff. The second Issues issue is Work Organization with with average percentage of (12 to 88), accordingly there is negative affection (Body, foot, back pain). The third issue is Tools, Equipment, and Furniture Design with average percentage (13 to 87), Resulting in the destruction of the classroom devices. The fourth issue is Workstation Design with average percentage (19 to 81), thus will affect in ICT classrooms with negatively on tools or equipment, with stiffness or cramping, and Compression or contact stress. The Fifth issues is Working in Prolonged Positions Sitting/Standing- with average percentage of (30 to 70), so the ICT class room students will be affecting with foot and back, Bending, and noise. The last issue is Work Environment with average percentage (41 to 59), accordingly there will be Very bad health environment,

Inconvenience and stress, Pain and shortness of breath and Eye strain for Sudanese ICT class rooms staff/students.

The overall participant's feedback on of the computer ergonomic issues has been applied in Sudanese HEI classroom shows that the average is 19% only applied correctly, while to average 81% were not applying the computer ergonomic issues which will affect negatively in the Sudanese higher education Institutions ICT class rooms.

In spite most of Sudanese HEI were using the ICT tools in their classrooms unfortunately they did belief the importance of ergonomic in the designing of their class rooms and computer equipment's

This research study contributes to the body of knowledge by explaining the basic procedures of computer ergonomic. The study harmonized the existing argument in the literature by enhancing the findings of Marklin, R., Simoneau. (2004) Hedge (1999).

The Limitations of this study is the participant of our questionnaire survey conducted within some Sudanese universities/ colleges, the results of the study therefore may not be generalizable to all other institutions.

7. REFERENCES

- Anderson, J. (1997). Integrating ICT and Other Technologies in Teacher Education: Trends, Issues and Guiding Principles [Electronic Version]. Info share: Sources and Resources Bulletin, pp. 33-35.
- Australian Government –Department of Education, Employment and Workplace Relations (2010) ICT Professional Learning: National Mapping of ICT-based Learning, Education Services Australia, Final Report, Melbourne.
- Cox, M., Preston, C. and Cox, K. (1999) What Factors Support or Prevent Teachers from Using ICT in their Classrooms? In British Educational Research Association Annual Conference. (Brighton: Ergonomics at Work Inc., Introduction to office ergonomics, 2002
- Sanders M.S., McCormick J., 1992, Human Factors in Engineering and Design, McGraw Hill International.
- Hedge, A., Morimot, S., McCrobie, D., 1999, "Effects of keyboard tray geometry on upper body posture and comfort," Ergonomics, 1999, Vol. 42, No. 10, pp. 1333–1349.
- Marklin, R., Simoneau, G., "Design Features of Alternative Computer Keyboards: A Review of Experimental Data, Journal of Orthopaedic & Sports Physical Therapy, 2004, Vol. 34, No. 10, pp. 638–49

FARKLILAŐTIRILMIŐ FEN VE TEKNOLOJİ ÖĖRETİMİNİN ÜSTÜN ZEKALİ VE YETENEKLİ ÖĖRENCİLERİN TUTUMLARINA ETKİSİ

THE EFFECT OF DIFFERENTIATED SCIENCE AND TECHNOLOGY INSTRUCTION ON GIFTED STUDENTS' ATTITUDE

Sezen CAMCI ERDOĖAN
Istanbul University
scamci@istanbul.edu.tr

Nihat Gürel KAHVECİ
Istanbul University
nihatgurel@yahoo.com

ABSTRACT: The aim of study is to determine the effectiveness of a differentiated program on attitudes of gifted students. For this purpose, one unit in Science and Technology course named "Earth, Sun and Moon" was differentiated on the bases of scientific creativity skills, Parallel Curriculum Model and Grid Model. The study was conducted with a total number of 21 students, 11 of them being in the experimental group and 10 of them being in the control group. The subjects were 5th grade students of a school in which gifted and talented students instructed in Istanbul. In order to collect data, The Scale of Attitude towards Science developed by Baykul (1990) was used. In the statistical analysis of data collected from these tests, mean, standard deviation, Mann Whitney-U and Wilcoxon Signed-Ranks Tests were used. The results of the study revealed that the differentiated science program developed for the gifted and talented students increased the attitude scores of the subjects towards science.

Key words: science, gifted, differentiation, attitude, curriculum

PROSPECTIVE MATHEMATICS TEACHERS' PREFERENCES FOR INSTRUMENTAL ORCHESTRATION TYPES AND ENDORSED NORMS

Tuğçe KOZAKLI

Rüya ŞAY

Hatice AKKOÇ

As a result of the emphasis on integrating technology into instruction, there is a growing need for research on teachers' and prospective teachers' choices, strategies, views and endorsed norms. This study aims to explore social and socio-mathematical norms embraced by prospective mathematics teachers during their technology-integrated lessons. Technology integration practices will be investigated through the lens of instrumental orchestration. With this aim, a case study was conducted. The participants of the study are two female prospective mathematics teachers who were enrolled in a teacher preparation course. Through collaboration, they prepared and taught a lesson on functions in one of the partnership schools using Graphics Calculus software. Data was collected through observations and semi-structured interviews. Findings will be discussed with regard to participants' preferences for orchestration types, social and socio-mathematical norms embraced by them and how these norms influence their preferences for using a particular orchestration type.

Keywords: Instrumental orchestration, social norms, socio-mathematical norms, prospective mathematics teachers

BİLİM SÖZDE-BİLİM AYRIMI BAĞLAMINDA PLANLANMIŞ ÖĞRETİM SÜRECİNİN ORTAOKUL ÖĞRENCİLERİNİN AKADEMİK BİLGİ DÜZEYLERİNE ETKİSİ

THE EFFECT OF THE TEACHING PROCESS PLANNED WITHIN THE CONTEXT OF SCIENCE –PSEUDOSCIENCE DISTINCTION ON THE ACADEMIC KNOWLEDGE LEVELS OF MIDDLE SCHOOL STUDENTS

Ertan ÇETİNKAYA
Yılmaz Mızrak Ortaokulu
ertancetinkaya@hotmail.de

Halil TURGUT
Sinop Üniversitesi
halilturgut@sinop.edu.tr

M. Kürşad DURU
Marmara Üniversitesi
mehmetkursad.duru@marmara.edu.tr

ÖZET: Bilimsel okuryazarlığın, bilimsel içerik – terminoloji boyutuna odaklanan bu çalışma bilim sözde-bilim ayrımı tartışması bağlamında planlanan bir öğretim sürecinin ortaokul öğrencilerinin akademik başarılarına etkisini araştırmaktadır. Araştırma sürecinde Fen Bilimleri Dersi Öğretim Programı'nda (MEB, 2006) yer alan kazanımlarla ilişkilendirilen sözde-bilimsel vakalar önceden planlanmış bir dizi etkinlik aracılığı ile öğrencilere sunulmuş, uygulamalar yaptırılmış ve hem genel hem de gruplar halinde tartışmaya konu edilmiştir. Çalışma grubunda 21 ortaokul son sınıf öğrencisinin yer aldığı araştırmanın veri toplama aracını, araştırmacılar tarafından geliştirilen “Akademik Bilgi Testi” (ABT) oluşturmuştur. ABT eğitim sürecinden önce ve sonra olmak üzere her öğrenciye toplam iki kez uygulanmıştır. ABT'den elde edilen veriler hem araştırmacı hem de fen eğitimi alanında uzman araştırmacılar tarafından farklı zamanlarda iki kez kodlanarak üç farklı kategoriye ayrılmıştır. Toplanan veriler PASW 18.0 paket programında analiz edilmiştir. İlişkili grupların testlerinin ölçülmesi için bağımlı değişkenlerin ordinal olduğu durumlarda İşaret ve Wilcoxon İşaretili Sıralar Testi'nin uygulanması (Siegel, 1957) önerildiğinden, analiz yapılırken toplanan verilere bahsi geçen testler uygulanmıştır. Ulaşılan bulgular, bilim sözde-bilim bağlamı esas alınarak hazırlanan etkinliklerin, öğrencilerin ilgili kazanımlara yönelik akademik bilgi düzeylerinde anlamlı bir farklılık oluşturduğunu ortaya koymaktadır.

Anahtar sözcükler: bilim sözde-bilim ayrımı, bilimsel okuryazarlık, bilimsel içerik – terminoloji

ABSTRACT: This study, which focused on the scientific content – terminology dimension of scientific literacy, aimed at investigating the effect of the teaching process planned within the context of debate on science – pseudoscience distinction on the academic achievement of middle school students. In the research process, pseudoscientific cases associated with the acquisitions included in the Science Course Curriculum (MEB, 2006) were presented to the students via a series of activities planned in advance. Then they were discussed both generally and in groups. The study group consisted of 21 final year middle school students. Data were collected by means of the “Academic Knowledge Test (AKT)” developed by the researchers. AKT was administered to each student twice: once at the beginning of the education process; and once at the end of the education process. The data obtained via AKT were divided into three different categories through two coding operations at different times by the researchers and the specialists in the field of science education. The collected data were analyzed by means of PASW 18.0. Sign test and Wilcoxon signed-rank test are suggested to be used for measuring the tests of associated groups when dependent variables are ordinal (Siegel, 1957). Thus, the above-mentioned tests were administered to the gathered data during analyses in the present study. The research findings revealed that the activities prepared within the context of science – pseudoscience distinction created a significant difference in the academic knowledge levels of the students regarding related acquisitions.

Key words: science – pseudoscience distinction, scientific literacy, scientific content – terminology

YILDIZLAR KONUSUNUN ÖĞRETİMİNE YÖNELİK BİR DERS MATERYALİNİN GELİŞTİRİLMESİ, UYGULANMASI VE ETKİLİLİĞİNİN DEĞERLENDİRİLMESİ

DEVELOPING, APPLYING AND EVALUATING THE EFFECTIVENESS OF THE TEACHING MATERIAL ABOUT STARS

Ümmü Gülsüm DURUKAN
Giresun Üniversitesi, Eğitim Fakültesi
ummugulsum.durukan@giresun.edu.tr

Eser ÜLTAY
Giresun Üniversitesi, Eğitim Fakültesi
eserultay@gmail.com

ÖZET: Bu çalışmanın amacı, yıldızlar konusunda yapılandırmacı öğrenme yaklaşımının 5E modeline uygun bir ders materyalinin geliştirilmesi, uygulanması ve etkililiğinin değerlendirilmesidir. Astronomi dersi kapsamında basit deneysel araştırma yöntemiyle yürütülen çalışmanın örneklemini Fen Bilgisi Öğretmenliği Anabilim Dalı 4.sınıfında öğrenim gören 25 öğretmen adayı oluşturmaktadır. Çalışmada, ön ve son test olarak kullanılmak üzere kelime ilişkilendirme testinden (KİT) yararlanılmıştır. KİT’ten elde edilen veriler frekanslanarak kavram ağları haline dönüştürülmüştür. Uygulamadan sonra yapılan KİT’in sonuçlarına yönelik kavram ağının, uygulama öncesi verileri ile oluşturulan kavram ağıyla paralellik göstermesine rağmen daha kompleks ve konuya yönelik daha fazla kavram içeren bir yapıya sahip olduğu görülmektedir. Bu kavram ağında ilk kavram ağında olmayan “hidrojen” ve “helyum” gibi yıldızların yapısına dair; “nötron yıldızı”, “beyaz cüce”, “dev yıldız”, “kütle”, “tür” ve “tayf” gibi yıldızların sınıflandırılmasına dair kavramlar bulunmaktadır. Sonuç olarak, öğretmen adaylarının yıldızlar hakkında istenilen düzeyde bilgi sahibi olmadıkları tespit edilse de, hazırlanan ve uygulanan materyalin adayların konu ile ilgili bilgilerinin gelişmesine katkı sağladığı söylenebilir.

Anahtar Sözcükler: Astronomi Eğitimi, Fen Bilgisi Öğretmen Adayı, Materyal Geliştirme, Yıldız, 5E Modeli

ABSTRACT: The purpose of this study is to develop, to apply and to evaluate the effectiveness of the teaching material about stars based on 5E model. At this study which was used the simple experimental model, the sample of the study consist of 25 teacher candidates who take the astronomy course from the Elementary Science Education department. As a data collection tool, the word association test (WAT) is used before and after the instruction. The data obtained from the WAT is determined the distribution of frequency and drawn the concept networks. Although the (2nd) concept network obtained from the WAT which is done after instruction have in common with the (1st) concept network obtained from the WAT which is done before instruction, it is seen that the 2nd concept network have a structure consisting of more complex and have more concepts. This concept network has concepts about stars’ structure like hydrogen and helium and concepts about stars’ classification like neutron star, white dwarf, giant star, mass, kind and spectrum, but the first one hasn’t. As a result, it can be said that the teaching material in this study contributed to the teacher candidate’s knowledge development of the subject.

Key words: Astronomy education, Elementary science teacher candidate, Designing material, Star, 5E model.

GİRİŞ

Evrenin ve evrendeki gök cisimlerinin meydana gelişini, yapısını ve hareketlerini geçmişten geleceğe doğru inceleyen ve temel bilimlerin içinde önemli bir yere sahip en eski bilim dallarından biri olan (URL-1) Astronomi’de yer alan konu ve kavramları son yıllarda araştırmacılar tarafından sıkça tercih edilen araştırma konuları arasında yer almaktadır. Literatür incelendiğinde; katılımcıların bilgi/anlama düzeylerini (İyibil, 2010; Taşcan, 2013; Ünsal, Güneş & Ergin 2001), kavram yanılgılarını (Bülbül, İyibil & Şahin, 2012; Ekiz & Akbaş, 2005; Emrahoğlu & Öztürk, 2009), kavramsal değişim süreçlerini (Ercan, Taşdere & Ercan, 2010; Şahin, Bülbül & Durukan, 2013), zihinsel modellerini (İyibil & Sağlam Arslan, 2010; Kurnaz & Değirmenci, 2012) ve tutumlarını (Bektaşlı, 2013; Canbazoğlu Bilici, Öner Armağan, Kozcu Çakır & Yürük, 2012; Uçar &

Demircioğlu, 2011; Wittman, 2009) inceleyen çeşitli çalışmaların yürütüldüğü görülmektedir. Ancak farklı şekillerde açıklanmaya ve çizilmeye çalışılan yıldızlar konusu az sayıda araştırmacının dikkatini çekmiş ve bu kavram ile ilgili çalışmalar yürütülmüştür. Bu araştırmacılardan Emrahoğlu ve Öztürk (2009), fen bilgisi öğretmen adaylarının; *yıldızın tanımıyla ilgili*: yıldızların gezegen olduğu, ışık gücünü Güneş' ten aldığı ve Güneş' in yıldız olmadığı; *yıldızların kütleleri renkleri ışınma güçleri arasındaki bağıntıyla ilgili*: ışınma gücü fazla olan yıldızların kırmızı, ışınma gücü az olan yıldızların ise mavi renkte görüneceğini düşündükleri ve *yıldızların ölümlüyle ilgili*: yıldızların büyüklükleri ile patlama sonucu oluşan ürün arasında doğru bağlantıyı kuramadıkları ve karadelik ile karanlık enerjiyi birbirine karıştırdıkları görülmektedir. Chiu, Weng, ve Chern (1993) çalışmalarında ilkokul üçüncü ve beşinci sınıf toplam 16 öğrencinin yıldızlara dair algılarını araştırmışlardır. Öğrencilerin yıldız kavramı ile ilgili sınırlı bilgilere sahip oldukları ve tanımlarının günlük yaşantılarına ve tamamlanmamış bilimsel bilgilere dayanmakta olduğu görülmüştür. Aynı kavramın anlaşılma düzeyini araştıran Agan (2004) lise ve üniversite 1. sınıf öğrencileri ile çalışmıştır. Çalışması kapsamında gerçekleştirilen lise seviyesindeki astronomi kursunun öğrencilerin kısa sürede yıldız kavramına ilişkin bilimsel bilgiler geliştirmelerine yardımcı olduğunu ortaya koymuştur. Bailey (2006), öğrencilerin yıldızlara ait anlamalarını ortaya çıkarmak amacıyla gerçekleştirdiği çalışmasında, öğrencilerin önemli bir bölümünün yıldızların gazlardan oluştuğunu düşündüğünü, yarısına yakınının yıldızların yandıklarından dolayı parladığına inandıklarını ve çok az bir bölümünün yıldızların enerji kaynağı olarak füzyon tepkimelerini kullandıklarını düşündüklerini göstermiştir. Öğretmen adaylarının yıldız kavramına yönelik zihinsel modellerini inceleyen İyibil ve Sağlam-Arslan (2010), geleceğin fizik öğretmenlerinin bilimsel olmayan bilgileri içeren zihinsel model türlerine sahip olduklarını ortaya çıkarmıştır. Yıldızlar konusuna yönelik bir öğrenme yaklaşımına dayalı olarak hazırlanan herhangi bir ders materyaline rastlanılmamış olması bu çalışmanın gerçekleştirilmesinin altında yatan temel gerekçedir. Bu bağlamda çalışmanın amacı, yıldızlar konusuna yönelik yapılandırmacı öğrenme yaklaşımına dayanan bir ders materyali geliştirmek, uygulamak ve etkililiğini değerlendirmektir.

YÖNTEM

Kontrol grubu olmaksızın aynı örneklem grubu üzerinde ön test-son test uygulaması yapılarak gerçekleştirildiğinden, çalışma basit deneysel araştırma yöntemiyle yürütülmüştür (Büyüköztürk, Kılıç Çakmak, Akgün, Karadeniz ve Demirel, 2012).

Örneklem

Çalışmanın örneklemini Fen Bilgisi Öğretmenliği Anabilim Dalı 4.sınıfında öğrenim gören ve astronomi dersini alan 25 öğretmen adayı oluşturmaktadır.

Veri Toplama Aracı ve Verilerin Analizi

Çalışmada veri toplama aracı olarak, Kelime İlişkilendirme Testi'nden (KİT) yararlanılmıştır. Öğrencilerin bilişsel yapısını incelemeyi kolaylaştıran bu teknik, kavram değişim stratejileri arasında ölçme-değerlendirme tekniği olarak kullanılmaktadır (Ercan ve diğerleri, 2010). Materyalin uygulanmasından önce ve materyal uygulandıktan sonra KİT uygulanmıştır. Ders içeriği ve literatürde yer alan çalışmalar incelenerek 7 tane anahtar kavram seçilmiştir. Seçilen anahtar kavramlar; evren, gökada, yıldız, gezegen, süpernova, karadelik ve Güneş'tir. Öğretmen adaylarına KİT'e yönelik açıklamalar yapılmış ve her bir kavram için bir dakika süre verilmiştir. Öğretmen adayları bu süre içerisinde anahtar kavram ile ilişkili olduğunu düşündüğü kelimeleri sırayla yazmıştır.

KİT analiz edilirken, kavram ağlarının hazırlanması için Bahar, Johnstone ve Sutcliffe (1999) tarafından ortaya konulan Kesme Noktası (KN) tekniği kullanılmıştır. İlk önce, hangi anahtar kavram için hangi kelimelerin yâda kavramların kaçar defa tekrarlandığını gösteren bir frekans tablosu oluşturulmuştur (EK-1). Bilişsel yapıyı ve kavramsal değişimi net bir şekilde göstermesi amacıyla bu frekans tablosu baz alınarak, kesme noktaları belirlenmiş ve kavram ağı oluşturulmuştur. Bu tekniği Ercan ve diğerleri (2010) kısaca aşağıdaki gibi açıklamışlardır.

“Kelime ilişkilendirme testinde yer alan herhangi bir anahtar kavram için en fazla verilen cevap kelimenin 3-5 sayı aşağısı kesme noktası olarak kullanılır. Bu cevap frekansın üstünde bulunan cevaplar kavram ağının ilk kısmındaki bölüme yazılır. Daha sonra kesme noktası belirli aralıklar ile aşağıya çekilir ve tüm anahtar kelimeler kavram ağında çıkıncaya kadar işlem devam eder.”

Çalışmamız için belirlenen kesme noktaları '20 ve yukarısı', '15-19 arası', '10-14 arası' ve '5-9 arası'dır. Her bir kesme noktası kavram ağında farklı bir renkle temsil edilmiştir.

BULGULAR

KİT'ten elde edilen verilerin analizi sonucunda, çizilen kavram ağları aşağıdaki şekilde sunulmuştur (Şekil.1).

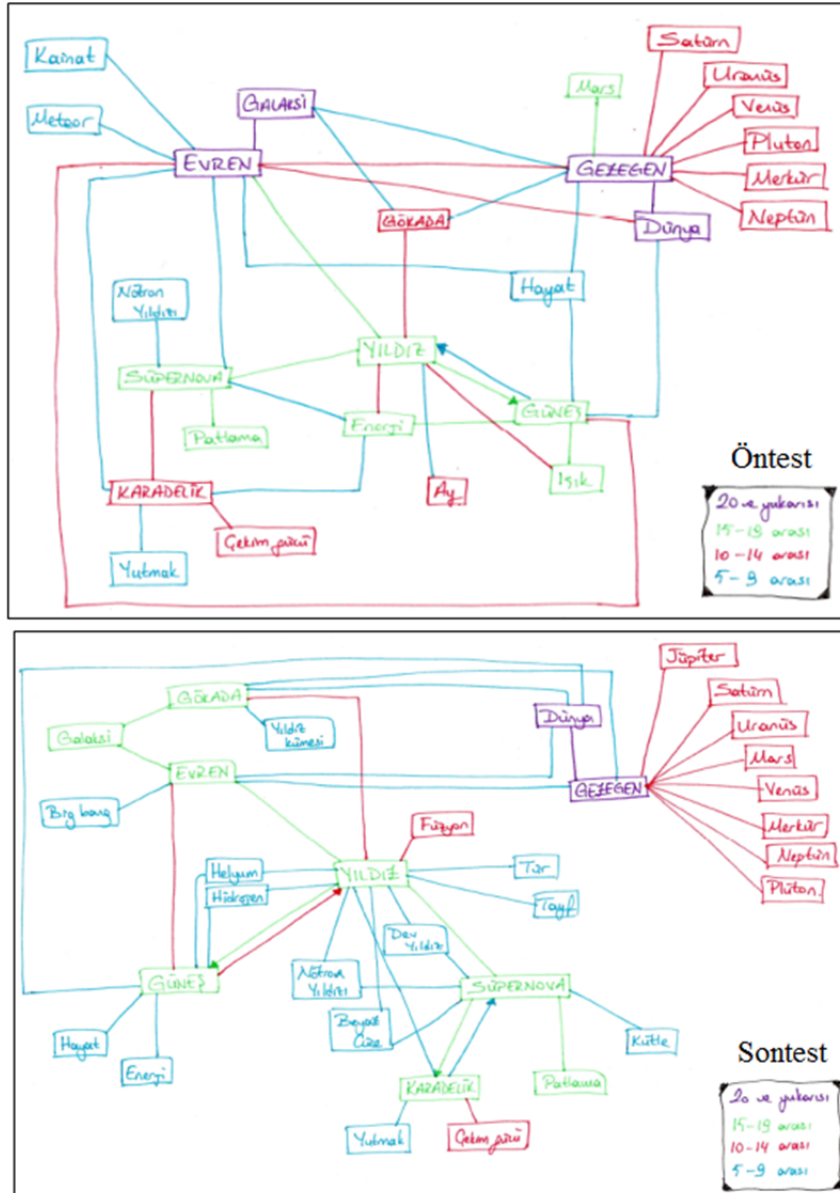

Şekil 1. Öğretmen Adaylarının KİT'ten Elde Edilen Kavram Ağları

Uygulamadan önce yapılan KİT sonuçları, öğretmen adaylarının aklına evren kavramı için, galaksi, yıldız, güneş, dünya, karadelik, kainat, hayat ve gezegen gibi farklı kavramlar geldiğini göstermektedir. Gökada denildiğinde gökadanın eş anlamlı ifadesi olan galaksi, yıldız ve gezegen kavramları adayların cevaplarıdır. Yıldız kavramı denildiğinde ay, güneş, enerji ve ışık akıllara gelmektedir. Gezegen denildiği ise adaylar ilk önce dünya, mars gibi gezegenleri sıralamışlardır. Bu kavram için galaksi ve hayat kelimelerini belirten adaylar da vardır. Süpernova kavramı için ise adaylar patlama, karadelik, yıldız ve nötron yıldızı ifadelerini kullanmışlardır. Beyaz cüce ifadesinin kullanılmamış olduğu görülmektedir. Karadelik denildiğinde ise adayların aklına çekim gücü, yutmak ve enerji ifadeleri gelmektedir. Son olarak güneş için adaylar, yıldız, enerji, hayat, ışık ve dünya kelimelerini belirtmişlerdir. Bu noktada dikkat çeken, adayların yıldız kavramı için Güneş'i dile getirdiği sayı, güneş kavramı için yıldız dile getirdiği sayıdan fazladır. Bu durumda adayların Güneş'in bir yıldız olduğu konusunda yanlışlara/tereddütlere sahip olduklarını gösterebilir.

Uygulamadan sonraki KİT sonuçları ise, ilk kavram ağıyla paralel kısımlara sahip olmasına rağmen daha kompleks ve konuya yönelik daha fazla kavram içeren bir yapıya sahiptir. Bu kavram ağında ilk kavram ağında olmayan hidrojen, helyum gibi yıldızların yapısına dair; nötron yıldızı, beyaz cüce, dev yıldız, kütle, tür ve tayf gibi yıldızların sınıflandırılmasına dair kavramlar bulunmaktadır.

SONUÇ

Yapılandırmacı öğrenme yaklaşımının 5E modeline dayalı geliştirilen ders materyalinin etkililiğini araştırmak amacıyla yapılan bu çalışma kapsamında elde edilen bulgular, öğretmen adaylarının konu hakkında daha fazla kavram ifade edebildiklerini göstermektedir. Bu durum, geliştirilen ders materyalinin etkili olduğunu gösterebilir. Son test olarak kullanılan KİT sonuçları ile oluşturulan kavram ağı daha kompleks ve konuyla ilgili daha çok kavrama sahiptir. Ancak öğretmen adaylarının konu ile ilgili kavramlar arasında henüz yeterince ilişki kuramadıkları da düşünülmektedir.

ÖNERİLER

Adayların astronomi dersi almasına rağmen yıldızlar konusunda yeterli düzeyde bilgiye sahip olmamaları önemli bir durumdur. Literatürde yer alan çalışmalarda da belirlenen, örneğin Emrahoğlu ve Öztürk (2009), katılımcıların sahip oldukları ‘sıcak yıldızlar kırmızıdır, yıldız ışık gücünü Güneş’ten almaktadır’ gibi yanlışlar ve ‘yıldızların büyüklükleri ile patlaması sonucu oluşan ürünler arasında ilişki kuramadıkları’ gibi bilgi eksiklikleri bu durumun kanıtı niteliğindedir. Dolayısıyla, katılımcıların yıldızlara ait algı ve bilgilerinin ortaya çıkarılması için daha ayrıntılı çalışmalar yapılmalı ve bu çalışmalar sayesinde ortaya çıkarılan eksikliklerin giderilmesi önerilebilir. Astronomi dersinin öğretimi sırasında yararlanılan öğretim yöntemleri değiştirilebilir ve bu çalışmada kullanılan ders materyali gibi materyaller hazırlanarak öğretmen adaylarının ilgisi derse yöneltilir. Bununla birlikte, görsel ve 3 boyutlu ders materyalleri kullanılarak öğrenme ortamları da zenginleştirilebilir. Ayrıca, konuda yer alan kavramlar arasındaki ilişkilere de vurgu yapmak amacıyla kavram haritası, anlam çözümleme tablosu gibi tekniklere de ders materyallerinde yer verilmesi önerilmektedir.

KAYNAKLAR

- Agan, L. (2004). Stellar ideas: Exploring students' understanding of stars. *Astronomy Education Review*, 3(1), 77-97.
- Bahar, M., Johnstone, A.H. & Sutcliffe, R.G. (1999). Investigation of students' cognitive structure in elementary genetics through word association tests. *Journal of Biological Education*, 33, 134-141.
- Bailey, J. M. (2006). Development of a concept inventory to assess students' understanding and reasoning difficulties about the properties and formation of stars. PhD Thesis, Arizona University, USA.
- Bektaşlı, B. (2013). The effect of media on preservice science teachers' attitudes toward astronomy and achievement in astronomy class. *The Turkish Online Journal of Educational Technology*, 12 (1), 139-146.
- Bülbül, E., İyibil, Ü. G. & Şahin, Ç. (2012, Mayıs). Sınıf öğretmen adaylarının gök cisimleri ile ilgili alternatif kavramlarının kavram karikatürleri ile belirlenmesi. 11. Ulusal Sınıf Öğretmenliği Eğitimi Sempozyumu Özet Kitapçığı, (s. 82- 83), Rize: Recep Tayyip Erdoğan Üniversitesi.
- Büyükköztürk, Ş., Kılıç Çakmak, E., Akgün, Ö. E., Karadeniz, Ş. & Demirel, F. (2012). *Bilimsel araştırma yöntemleri*. (Geliştirilmiş 13.baskı). Ankara: PegemA Yayıncılık.
- Canbazoğlu Bilici, S., Öner Armağan, F., Kozcu Çakır, N. & Yürük, N. (2012). Astronomi tutum ölçeğinin Türkçe'ye uyarlanması: Geçerlilik ve güvenilirlik çalışması. *Türk Fen Eğitimi Dergisi*, 9(2), 117-127.
- Chiu, M. H., Weng, S. C. & Chern, I. S. (1993). Children's concepts about the stars. Annual Meeting of Australian Association for Research in Education, Fremantle, Western Australia. <http://www.aare.edu.au/93pap/chium93037.txt>, 17 Mayıs 2013.
- Emrahoğlu, N. & Öztürk, A. (2009). Fen bilgisi öğretmen adaylarının astronomi kavramlarını anlama seviyelerinin ve kavram yanlışlarının incelenmesi üzerine boylamsal bir araştırma. *Çukurova Üniversitesi Sosyal Bilimler Enstitüsü Dergisi*, 18 (1), 165-180.
- Ercan, F., Taşdere, A. & Ercan, N. (2010). Kelime ilişkilendirme testi aracılığıyla bilişsel yapısı ve kavramsal değişimin gözlenmesi. *Türk Fen Eğitimi Dergisi*, 8(1), 136-153.
- İyibil, Ü. G. & Sağlam Arslan, A. (2010). Fizik öğretmen adaylarının yıldız kavramına dair zihinsel modelleri. *Necatibey Eğitim Fakültesi Elektronik Fen ve Matematik Eğitimi Dergisi*, 4(2), 25-46.
- Kurnaz, M. A. & Değermenci, A. (2012). 7.sınıf öğrencilerinin güneş, dünya ve ay ile ilgili zihinsel modelleri. *İlköğretim-Online*, 11 (1), 137-150.
- Şahin, Ç., Bülbül, E. & Durukan, Ü. G. (2013, Kasım). Öğrencilerin gök cisimleri konusundaki alternatif kavramlarının giderilmesinde kavram karikatürlerinin etkisi. Uluslararası Eğitimde Değişim ve Yeni Yönelimler Sempozyumu, Konya: Necmettin Erbakan Üniversitesi.
- Taşcan, M. (2013). Fen bilgisi öğretmenlerinin temel astronomi konularındaki bilgi düzeylerinin belirlenmesi (Malatya ili örneği). Yüksek Lisans Tezi, İnönü Üniversitesi, Eğitim Bilimleri Enstitüsü, Malatya.

Uçar, S. & Demircioğlu, T. (2011). Changes in preservice teacher attitudes toward astronomy within a semester long astronomy instruction and four year-long teacher training program. *Journal of Science Education and Technology*, 20(1), 65-73.

URL-1, <http://www.zamandayolculuk.com/cetinbal/HTMLdosya1/Astronomikavramlari.htm>, 20 Nisan 2014.

Ünsal, Y., Güneş, B. & Ergin, İ. (2001). Yükseköğretim öğrencilerinin temel astronomi konularındaki bilgi düzeylerinin tespitine yönelik bir araştırma. *Gazi Üniversitesi Gazi Eğitim Fakültesi Dergisi*, 21(3), 47-60.

Wittman, D. (2009). Shaping attitudes toward science in an introductory astronomy class. *The Physics Teacher*, 47, 591-594.

EK-1. KİT'e Ait Frekans Tablosu

Cevap kelimeler	Evren		Gökada		Yıldız		Gezegen		Süpernova		Karadelik		Güneş	
	Ön test	Son test	Ön test	Son test	Ön test	Son test	Ön test	Son test	Ön test	Son test	Ön test	Son test	Ön test	Son test
Galaksi	21	17	8	15	3	2	9	2	1				2	2
Yıldız	18	15	14	13					16	13	4	8	9	12
Uydu				1	1		2	1						
Ay	3	1	1		5									1
Meteor	5	1	4	2	1		1							
Süpernova	5		2	1	4	15					3	6		
Nötron yıldızı					2	8			5	9	3	3		
Güneş	12	10	2	1	16	17	4	1	4	1	1	2		
Jüpiter			1		1		13	14						
Enerji		1			10	2			6	2	5	1	15	8
Dünya	12	8	1	7			22	20	1				5	6
Satürn							10	14						
Uranüs			1				13	14						
Mars							16	13						
Venus					2		10	11						
Plüton							11	11						
Merkür			1				10	10						
Patlama					2	2			16	18	1		4	
Karadelik	9	2	2		3	3			11	15				
Yutmak											6	5		
Işık					11	4			2		4	1	16	2
Çekim gücü									2		12	13		
Yenilenebilir														1
Hidrojen					1	7							3	5
Helyum					1	7							4	5
Alem	1	1												
Kainat	5	2	1		1				1		1		1	
Hayat	5	2			2		5	1					9	7
Yıldız kümesi		2	1	7										
Gezegen	12	9	5	7	1		1				1		1	
Neptün							11	12						
Sıcaklık					1					1			1	1
Uydu							1							
Uzay	3	1	2				1	1	1		1	1		
Kuyruklu yıldız	1				2									
Füzyon					1	10							2	1
Beyaz cüce					1	6			1	7				
Topluluk			3											
Elektrik süpürgesi											1	2		
Big bang	3	8							1					
Nebula													1	
Bayrak					3									
Tür						6								
Akdelik												4		
Dev yıldız						8				9				
Kütle										7		3		
Tayf						9								

2005 VE 2013 FEN BİLİMLERİ DERSİ ÖĞRETİM PROGRAMINA GÖRE HAZIRLANMIŞ 5. SINIF DERS KİTAPLARINDA YER ALAN ETKİNLİKLERİN ÇEŞİTLİ YÖNLERDEN İNCELENMESİ

Şahin İDİN
sahinidin@hotmail.com
İpek Yolu Orta Okulu

Doç. Dr. Cemil AYDOĞDU
c.aydogdu@hacettepe.edu.tr
Hacettepe Üniversitesi

ÖZET: Bu araştırmanın amacı, 2005 ve 2013 Fen Bilimleri Dersi Öğretim Programına göre hazırlanmış olan 5. Sınıf Fen Bilimleri ders kitaplarında yer alan etkinliklerin çeşitli yönlerden incelenmesidir. Çalışma kapsamında 2012-2013 eğitim öğretim yılında okutulan iki Fen Bilimleri ders kitabı ve 2013-2014 eğitim öğretim yılında 5. Sınıflar için okutulan iki Fen Bilimleri ders kitabı analiz edilmiştir. Araştırmanın türü nitel araştırmadır. Veriler doküman analizi tekniği ile çözümlenmiştir. Buna göre 2005 programına göre hazırlanan ders kitaplarında yer alan etkinlik sayısının daha fazla olduğu belirlenmiştir. 2005 programına göre hazırlanan çalışma kitaplarında yer alan etkinliklerin öğrencileri değerlendirmeye yönelik hazırlandıkları belirlenmiştir. Araştırmanın sonunda bulgulara dayalı olarak önerilere yer verilmiştir.

Anahtar Sözcükler: Fen Bilimleri, Nitel araştırma, Etkinlik

PREPARED BY ACCORDING TO 2005 AND 2013 SCIENCE CURRICULUM 5TH GRADE TEXTBOOKS INVESTIGATION FROM VARIOUS ASPECTS OF THE ACTIVITIES

Şahin İDİN
sahinidin@hotmail.com
İpek Yolu Secondary School

Assoc. Prof.Dr. Cemil AYDOĞDU
c.aydogdu@hacettepe.edu.tr
Hacettepe University

ABSTRACT The purpose of this study, prepared by according to 2005 and 2013, Science Curriculum 5th Grade Science in textbooks is to examine various aspects of the activities. Working under the 2012-2013 academic year two of Sciences taught in textbooks and in the academic year 2013-2014 for Grade 5 Science textbook taught two were analyzed. The type of research is qualitative research. Data were analyzed by document analysis techniques. According to the 2005 program prepared by the higher number of events taking place in the textbooks was determined. 2005 program of events taking place in the workbook prepared by the students were determined to be prepared for evaluation. At the end of the study recommendations are given based on the evidence.

Keywords: Natural sciences, qualitative research, activity

TURKISH VERSION OF STATISTICAL REASONING ASSESSMENT (SRA)

Rabia KARATOPRAK

Gülseren KARAGÖZ AKAR

The purpose of this study is to adapt Statistical Reasoning Assessment (SRA) (Garfield, 2003) in Turkish context. SRA was developed in 1998 and was distributed in the field in 2003. SRA was also used as a valid and reliable instrument in some other studies (Garfield, 1998; Garfield, 2003; Templear, 2004). In order to adapt SRA, processes of i) translation, ii) determining equivalence of the items, iii) examining validity and reliability of the instrument were done (e.g. Hambleton & Patsula, 1998; Kılıçer & Odabaşı, 2010). For “i”, it is translated to Turkish language by three people including the first researcher. The first researcher and the second author edited the translated test independently and they discussed and reached upon an agreement about the final version of the test. For “ii”, three experts studying in the related area reviewed the original and adapted version of SRA to examine equivalency of the two forms. Also one measurement expert and graduate students discussed the equivalency of the items in a four hour period. For “iii”, experts agreed on both forms of SRA as equivalent. Since the original version was valid and both forms were equivalent, the adapted version was accepted as valid based on the judgmental decisions of the experts. Judgmental decisions about the validity of an instrument could be sufficient as long as cross-cultural comparison will not be done (Hambleton & Patsula, 1998). Then 73 monolingual university students taking undergraduate education in English took the original version and 3 weeks later they retok the Turkish version. Pearson-r correlation coefficient was calculated. Since test-retest reliability analysis was used in original study, test-retest reliability analysis is still to be conducted. Since this is an ongoing research study, in the full text submission, results of the analysis at a final stage will be provided.

Keywords: statistics education, statistical reasoning, assessment,

HOW DO THE PUPILS' PARENTS TAKE A STAND TO THE STUDYING OF THE CRAFTS IN FINLAND?

Antti HILMOLA

I carry out the research project of the crafts 2013-2014 in Finland at the moment. In Finnish basic education, the subject of crafts includes two different tracks, technical work and textile work. The curriculum is common in which technological know-how is emphasized. The research material consists of the parents' questionnaire, teacher questionnaire and pupil questionnaire. Except for the parents' questionnaire, the collecting of the research material is unfinished. In this paper the starting points and the results of the parents' questionnaire are examined. In the parents' questionnaire, the parents (N = 1390) of the pupils of the seventh grade in Finnish basic education took a stand both to the skills of the crafts of their children and to the interestingness and the usefulness of the crafts subject. The questionnaire was carried out as a Survey type electronic questionnaire in the Internet at the end of the year 2013.

According to the parents of the pupils of the seventh grade, their children know the crafts well and they regard the subject as interesting. Furthermore, according to the opinion of parents, the crafts subject is a useful subject from the viewpoint of the future of their children. Results of this kind: Are opposite in relation to the Finnish education policy. According to the time allocated for lessons in basic education (Act of Finnish Government 2012), the number of classroom hours devoted to crafts will decrease in the upper grades beginning in 2016. The change is questionable from the viewpoint of educational policy. Pupils and the pupils' parents will not be listened to when the Finnish school system is developed. The school is developed as civil servant decisions.

Keywords: crafts subject, parents' questionnaire, education policy,

OKUL ÖNCESİ EĞİTİMDE STEM UYGULAMALARINA YÖNELİK ÖĞRETMEN GÖRÜŞLERİ

OPINIONS OF TEACHERS ON STEM APPLICATIONS IN PRESCHOOL EDUCATION

Suat ŞAHİN
Kayseri İl Mili Eğitim Müdürlüğü
kayseristem@gmail.com

Yeşim ÖZGENOL
Kayseri İl Mili Eğitim Müdürlüğü
kayseristem@gmail.com

Betül AKBULUT
Kayseri İl Mili Eğitim Müdürlüğü
kayseristem@gmail.com

Betül HASCANDAN
Kayseri İl Mili Eğitim Müdürlüğü
kayseristem@gmail.com

Ayşecik GÜLEY
Kayseri İl Mili Eğitim Müdürlüğü
kayseristem@gmail.com

ÖZET: Çağımızın değişen şartlarına bağlı olarak ortaya çıkan ihtiyaçlar göz önüne alındığında, fen ve matematik eğitiminin salt teorik yaklaşımlardan ziyade disiplinler arası işbirliği yaklaşımı ile yürütülmesi kaçınılmaz bir gereksinimdir. Bu doğrultuda ortaya çıkan STEM eğitimi, klasik ve ezbere dayalı eğitim yaklaşımları yerine, disiplinler arası işbirliğini temel alan, ilişkilendirme, problem çözme becerileri ekseninde bir eğitim modelidir. STEM uygulamaları eğitimin her kademesinde kullanılabilir. Bu bağlamda bireyin öğrenmelerinin temelini oluşturacak okul öncesi eğitimi önemli bir yer tutmaktadır. Bu çalışmada Okul öncesi STEM uygulamalarına yönelik öğretmen görüşlerini belirlemek amaçlanmıştır.

Araştırma Kayseri İl Millî Eğitim Müdürlüğü tarafından yürütülen STEM projesi kapsamında pilot okul olarak belirlenen Melikgazi Anaokulunda gerçekleştirilmiştir. Araştırmada veri toplanırken okul öncesi eğitimde STEM uygulamalarına yönelik anket ve gözlem tekniklerinden faydalanılmıştır. Etkinlikler 4 ay boyunca devam etmiş, elde edilen nicel veriler SPSS 17.00 paket programı aracılığı ile 0,05 anlamlılık düzeyinde değerlendirilmiştir. Araştırma sonucunda, öğretmenlerin okul öncesi STEM uygulamalarına yönelik olumlu görüşlere sahip oldukları belirlenmiştir.

Anahtar sözcükler: Okul öncesi, STEM, Öğretmen.

ABSTRACT: The STEM education emerging with this motivation is an education model based on interdisciplinary cooperation focusing on reasoning and problem solving skills instead of classical and memorization based education approaches. STEM applications can be used in every stage of the education. In this context, preschool education, which lays the foundation for the personal development, is a very important phase. The goal of this study is to determine the opinions of teachers towards preschool STEM applications

Study is carried out in Melikgazi Kindergarten that is selected by the Kayseri Provincial Directorate for National Education. Surveys and observations are utilized for collecting data on STEM applications in preschool education. The activities are carried out for four months and the data is analyzed using the SPSS 17.00 software at 0.05 significance level. The study concluded that the teachers have positive opinion for STEM applications.

Key words: pre-school, STEM, Teacher

GİRİŞ

Teknolojik gelişmelerin yaşamımızın her alanında etkisinin görüldüğü günümüzde gelişmiş ülkeler yetiştirdikleri bireylerin; fen ve teknoloji okur-yazarı olmalarının yanı sıra, bilgi teknolojilerini etkili kullanma, problem çözme, eleştirel düşünme, sorumluluk alma ve takım çalışması yapma gibi üst düzey becerilere de sahip olmalarını beklemektedir(Çavaş, Özdoğru& Kesercioğlu, 2012). Bu sayede bireylerin kazandıkları bilgi ve becerileri günlük yaşama transfer edebilmesi, her gün karşılaştıkları yeni problemlere çözüm yolları üretmeleri amaçlanmaktadır. Bunun en önemli nedeni ülkelerin ekonomik ve bilimsel alanda uluslararası arenada kendini gösterebilmesi ancak inovasyon sayesinde olabilmesidir. İnovatif faaliyetlerinin gerçekleşebilmesi ise bu alanlarda yetişmiş nitelikli insan gücüne bağlıdır. Tabi ki bu alanlarda takım çalışması ve disiplinler arası çalışma son derece önemlidir. Çağımızın bu değişen ihtiyaçlarını karşılayabilmek için bir ülkenin bilimsel ve ekonomik alanlardaki liderliğinin ve yetkinliğinin sağlanması ve sürdürülmesi amacıyla STEM eğitimi ihtiyacı ortaya çıkmıştır.

STEM (Science- Technology- Engineering-Mathematics) disiplinler arası bir öğrenim yaklaşımıdır. Bu yaklaşımda amaç akademik disiplinleri gerçek hayattan konularla ilişki kurularak öğrencilerin bilimi, teknolojiyi, mühendislik ve matematik konularını okul, toplum, iş ve küresel girişimlerde kullanarak; yeni ekonomide rekabet edebilecek çağın gereklerine uygun STEM okuyuzarları yetiştirmesidir. Bir ülkenin ekonomideki başarısının temelini eğitim olduğu düşünüldüğünde bu alanda söz sahibi olmak isteyen ülkeler için STEM eğitimi kaçınılmaz bir gereksinimdir.

STEM eğitimleri farklı yaş guruplarını, okul öncesi eğitimden doktora sonrası eğitimlere kadar okul içi ve dışı eğitimleri kapsayan bir yaklaşımdır. Bu dönemler içerisinde bireyin sonraki yaşamındaki öğrenmelerinin temelini oluşturacak okul öncesi eğitimi son derece önemli bir yer tutmaktadır. Çocukların öğrenme kalitesini artırmak, öğrenmelerini kolaylaştırmak, onları öğrenmeye karşı istekli kılmak, araştırma yapmaya teşvik etmek ve öğrenmelerini anlamlı hale getirmek okulöncesi dönemde kullanılan pek çok yeni yaklaşımın hedefleri arasındadır (Çakar ve Üstün, 2006). Bu dönemde neden-sonuç ilişkilerini kurabilen, problemleri tanımlayıp çözümler üretebilen, yaratıcı bireyler yetiştirmek için çocukların yaşayarak, deneyerek, gözlem yaparak, kendisini keşfetmesine olanak sağlayan öğrenme ortamları hazırlamak son derece önemlidir (Şahin, 2006). Bu açıdan bakıldığında okul öncesi eğitimde STEM uygulamaları, istenilen düzeyde bir STEM eğitiminin gerçekleşmesi için bir zorunluluktur.

STEM disiplinlerinin içerisinde Fen ve Matematik önemli bir yer tutmaktadır. Eğer fen programında istenilen başarıya ulaşmak isteniyorsa okul öncesi düzeyinden başlayarak çocuklara araştırma yapma olanağı verilmelidir (Howe, 1975) Çocukları bilim ile tanıştırmada en iyi zaman onların çevrelerindeki dünyayı merak etmeye başladıkları zamandır. Meraklı olmak çocukların doğası gereğidir ve bilimsel duyarlılığın geliştirilmesi için bir temeldir (Akman ve diğ., 2011). Dikkatleri çok kısa süreli olan okul öncesi dönem öğrencilerinin etkinliklere daha uzun süreli katılımlarının sağlanması için öğretmenlere büyük sorumluluklar düşmektedir (Yaşar, 1993).

Okul öncesi eğitimde öğrencilerin bu alanlarda yönlendirilmesinde ve gelişiminde öğretmenlerin rolü büyüktür. Çocukların bilim ile tanıştırılmasında en iyi zaman olan okul öncesi eğitimde, bilimsel süreç becerilerinin ve yeterliliklerinin kazandırılmasında okul öncesi eğitim öğretmenlerinin; nitelikli bir eğitim vermesi, buna yönelik bir ortam oluşturabilmesi ve kazandırılması istenilen yeterlilikler için uygun materyal ve yöntemi tespit edebilmesi, bilimsel düşünme süreçlerini etkin bir şekilde kullanabilmesi gereklidir.

Bu çalışmada okul öncesi Kayseri İl Millî Eğitim Müdürlüğü bünyesinde yürütülen STEM projesi kapsamında pilot okul olarak belirlenen Melikgazi Anaokulundaki STEM uygulamalarına yönelik öğretmen görüşlerini tespit etmek amaçlanmıştır.

YÖNTEM

Durum çalışması yaklaşımı kullanılarak (Meriam,1988) yürütülen bu çalışmada okul öncesi öğretmenlerinin STEM uygulamalarına yönelik görüşlerini tespit etmek amaçlanmıştır.

Araştırma Grubu

Çalışma grubunu, Kayseri İl Millî Eğitim Müdürlüğü bünyesinde yürütülen STEM projesi kapsamında pilot okul olarak belirlenen ve STEM uygulamalarının gerçekleştiği Melikgazi Anaokulunda görev yapan 20 öğretmen oluşturmuştur.

Uygulama Yöntemi

Uygulamalar eylül ayı itibarı ile başlamış ocak ayında sonlandırılmıştır. Uygulamalar için Cuma günleri STEM günü olarak belirlenmiş ve bu günde önceden belirlenen STEM uygulamaları bütün sınıflarda eş zamanlı olarak gerçekleştirilmiştir. Uygulamalar esnasında STEM eğitimi için özel olarak kullanılan Fischer Teknik BASIC, Edu EVA ve Edu TIP materyalleri ayrıca etkinliklere uygun okul öncesi eğitim materyalleri kullanılmıştır. Yapılan uygulamalar okul öncesi eğitim müfredatına uygun olarak gerçekleştirilmiştir. Gerçekleştirilen uygulamalar; 3 boyutlu modeller oluşturma, vücudumu tanıyorum, Mıknatıs, uzayı tanıyorum, Bitki büyümesi ve gelişmesi, Mevsimlerin oluşumu, basit makineler, renk oluşumu, matematik uygulamalarıdır.

Veri Toplama Aracı ve İstatistiksel Analiz

Araştırma ile ilgili veriler “Okul öncesi Eğitimde STEM Eğitim Materyallerinin Kullanımına Yönelik Anket” uygulamalar sonrası öğretmenlere uygulanmıştır.

Araştırmada kullanılan, “Okul öncesi Eğitimde STEM Eğitim Materyallerinin Kullanımına Yönelik Anket”in orijinal hali Kol(2012) tarafından geliştirilmiş ve araştırmacılar tarafından uyarlanmıştır. Araştırmada kullanılan anket iki bölümden oluşmaktadır; birinci bölümde kişisel bilgiler, ikinci bölümde ise öğretim materyallerine ilişkin beşli likert türünde (1)Hiç katılmıyorum-HK, (2) Katılmıyorum-Ktm, (3) Kararsızım-Kar, (4)Katılıyorum-K, (5)Tamamen katılıyorum-TK şeklinde olmak üzere toplam 20 madde mevcuttur.

Bu araştırmada uygulamadan elde edilen nicel veriler SPSS 17.00 paket programı kullanılarak analiz edilmiştir. Öğretmenlerin kıdem durumları ve mezun olunan okul türüne göre farklılıkları ile “Okul öncesi Eğitimde STEM Eğitim Materyallerinin Kullanımına Yönelik Anket” puanları arasında anlamlı fark olup olmadığını belirlemek için ki-kare testi kullanılmıştır. Veriler 0,05 anlamlılık düzeyinde değerlendirilmiştir.

BULGULAR

Uygulamalar tamamlandıktan sonra “Öğretmen kişisel formu, Okul öncesi Eğitimde STEM Eğitim Materyallerinin Kullanımına Yönelik Anket” uygulamalar esnasında yapılan gözlemler sonucunda elde edilen bilgilerin analizi sonrası çıkan sonuçlar;

Okul öncesi Eğitimde STEM Eğitim Materyallerinin Kullanımına Yönelik Anket Sonuçları

Araştırma sonucunda öğrencilere uygulanan Okul öncesi Eğitimde STEM Eğitim Materyallerinin Kullanımına Yönelik Anket sorularına katılımcıların verdiği sonuçlar tablo.1 de verilmiştir.

Tablo 1. Araştırmada Kullanılan Okul Öncesi Eğitimde STEM Eğitim Materyallerinin Kullanımına Yönelik Anket Soruları ve Araştırmaya Katılan Öğrencilerin Sorulara Verdiği Cevapların Dağılımı

	HK(1)		Ktm(2)		Kar(3)		K(4)		TK(5)		Ort
	f	%	f	%	f	%	F	%	f	%	
1. STEM eğitim materyallerinin kullanımı okul öncesi eğitime katkı sağlar.	0	0	3	15	2	10	4	20	11	55	4,15
2. Etkinliklerde STEM materyali kullanmak zaman kaybıdır.	10	50	4	20	5	25	1	5	0	0	1,85
3. STEM eğitimi okul öncesi eğitimin kalitesini yükseltir.	0	0	2	10	4	20	5	25	9	45	4,05
4. STEM eğitim materyalleri çocukların cesaret duygusunu geliştirir.	0	0	0	0	4	20	10	50	6	30	4,1
5. STEM eğitimi okul öncesi dönem çocuklarını üst düzeyde güdüler.	0	0	2	10	3	15	7	35	8	40	4,05
6. STEM eğitimi okul öncesi etkinliklerini daha zevkli hale getirir.	0	0	0	0	4	20	10	50	6	30	4,35
7. STEM eğitimi okul öncesi çocuğunun dikkatini dağıtır.	8	40	10	50	0	0	2	10	0	0	1,8
8. STEM eğitimi materyallerini kullanabilmek için teknik bilgilerim yeterlidir.	2	10	4	20	4	20	9	45	1	5	3,15
9. STEM eğitim materyallerinin kullanımı grupla birlikte hareket etme ve gruba uyma alışkanlığı kazandırarak çocukların sosyalleşmesini sağlar.	0	0	0	0	2	10	10	50	8	40	4,3
10. Okul öncesi eğitimde STEM materyal eğitimi gereksizdir.	11	55	5	25	2	10	2	10	0	0	1,75

11. STEM eğitimi okul öncesi eğitimde kullanılan öğretim yöntemlerine uygundur.	0	0	2	10	5	25	10	50	3	15	3,7
12. Deneyimli öğretmenlerin nitelikli bir eğitim verebilmeleri için STEM eğitim materyallerine ihtiyaç yoktur.	9	45	9	45	0	0	2	10	0	0	1,75
13. Görsellik açısından okul öncesi etkinliklerde STEM eğitim materyallerini kullanmak önemlidir.	0	0	4	20	3	15	7	35	6	30	3,75
14. STEM eğitimi okul öncesi öğretmenini daha etkin kılar.	0	0	4	20	2	10	8	40	6	30	3,8
15. STEM eğitimi öğretmen-öğrenci etkileşimini azaltır.	9	45	7	35	1	5	3	15	0	0	1,9
16. STEM eğitimi bilginin daha kalıcı olmasını sağlar.	0	0	2	10	2	10	5	25	11	55	4,25
17. STEM eğitim materyalleriyle yapılan etkinlikler okul öncesi dönem çocuğunun gelişim düzeyini arttırmaktadır.	0	0	2	10	2	10	9	45	7	35	4,05
18. STEM eğitimi çocuğun gelişimine olumlu katkı sağlar.	0	0	0	0	2	10	7	35	11	55	4,45
19. STEM eğitim materyallerinin kullanılması, çocuklara daha çok zaman ayırmama ve ilgilenmeme olanak sağladı.	1	5	5	25	5	25	8	40	1	5	3,15
20. STEM eğitiminde etkinlikler süresince soyut kavramların somutlaştırılmasında oldukça etkilidir.	0	0	1	5	2	10	10	50	7	35	4,15

Tablo 1. İncelendiğinde öğretmenlerin STEM eğitim materyallerinin kullanımı okul öncesi eğitime olumlu katkı sağlar maddesinde %55'inin tamamen katıldığı %20'sinin ise katıldığı ve ortalama puanının 4,15 olduğu görülmüştür. STEM eğitim materyalleri çocukların cesaret duygusunu geliştirir maddesinde %30'unun tamamen katıldığı %50'sinin ise katıldığı ve ortalama puanının 4,10 olduğu görülmüştür. STEM eğitim materyallerinin kullanımı grupla birlikte hareket etme ve gruba uyma alışkanlığı kazandırarak çocukların sosyalleşmesini sağlar maddesinde %40'ının tamamen katıldığı %50'sinin ise katıldığı ve ortalama puanının 4,30 olduğu görülmüştür. STEM eğitimi bilginin daha kalıcı olmasını sağlar maddesinde %55'inin tamamen katıldığı %25'inin ise katıldığı ve ortalama puanının 4,25 olduğu görülmüştür. STEM eğitim materyalleriyle yapılan etkinlikler okul öncesi dönem çocuğunun gelişim düzeyini arttırmaktadır maddesinde %35'inin tamamen katıldığı %45'inin ise katıldığı ve ortalama puanının 4,05 olduğu görülmüştür. STEM eğitimi çocuğun gelişimine olumlu katkı sağlar maddesinde %55'inin tamamen katıldığı %35'inin ise katıldığı ve ortalama puanının 4,45 ile en yüksek puan olduğu görülmüştür. Okul öncesi eğitimde STEM materyal eğitimi gereksizdir ve Deneyimli öğretmenlerin nitelikli bir eğitim verebilmeleri için STEM eğitim materyallerine ihtiyaç yoktur maddeleri 1,75 ile en düşük puana sahip olduğu görülmüştür.

Öğretmenlerin Mesleki Deneyimleri Değişkenine Göre Okul Öncesi Eğitimde STEM Eğitim Materyallerinin Kullanımına Yönelik Anket Sonuçları

Araştırmaya katılan öğretmenlerin mesleki deneyimlerine göre Okul Öncesi Eğitimde STEM Eğitim Materyallerinin Kullanımına Yönelik Anket puanları incelenmiş olup elde edilen sonuçlara göre istatistiksel açıdan anlamlı bir fark bulunmamıştır.

Öğretmenlerin Mezun Oldukları Fakülte Değişkenine Göre Okul Öncesi Eğitimde STEM Eğitim Materyallerinin Kullanımına Yönelik Anket Sonuçları

Araştırmaya katılan öğretmenlerin mezun oldukları fakültele göre Okul Öncesi Eğitimde STEM Eğitim Materyallerinin Kullanımına Yönelik Anket puanları incelenmiş olup elde edilen sonuçlar; STEM eğitimi materyallerini kullanabilmek için teknik bilgilerim yeterlidir maddesinde istatistiksel açıdan anlamlı bir fark bulunurken ($\chi^2=6,021$; $P=0.046 < 0.05$) diğer maddelerde anlamlı bir farka rastlanmamıştır.

SONUÇ

Araştırma sonucunda, öğretmenlerin okul öncesi STEM uygulamalarına yönelik oldukça olumlu görüşlere sahip oldukları belirlenmiştir. Etkinlikler boyunca yapılan gözlemler ve etkinlikler sonrasında uygulanan anket sonuçlarına göre okul öncesi öğretmenlerinin; okul öncesi eğitimde STEM uygulamalarının okul öncesi eğitime katkı sağladığı, çocukların cesaret duygusunu geliştirdiği, bilgilerin daha kalıcı hale gelmesini sağladığı, çocuk gelişimine olumlu katkı sağladığı yönünde görüşlere sahip olduğu belirlenmiştir. Ayrıca STEM uygulamalarının ve materyal kullanımının birlikte hareket etme ve gruba uyma alışkanlığı kazandırmasında öğretmenlerin olumlu görüş bildirmesi araştırmanın ilgi çekici sonuçlarından biri olarak karşımıza çıkmaktadır. Çünkü STEM eğitiminin amaçlarından ve sağladığı faydalardan biri de ekip çalışmasıdır.

Literatürde yapılan çalışmalar okul öncesi öğretmenlerinin fen eğitimine yönelik olumlu ya da olumsuz düşünceye sahip olmanın önemi üzerinde durmaktadır. Öğretmenlerin düşüncelerinin yalnızca kendilerini etkilemediği aynı zamanda sınıf içindeki fen etkinlikleri ve dolayısıyla çocukların fen eğitimine karşı düşüncelerinin olumlu ya da olumsuz olmasını da etkilediği görülmektedir(Kefi,2013). Bu açıdan araştırma sonucunda STEM eğitimi ve uygulamalarına yönelik öğretmen görüşlerinin olumlu çıkması son derece önemlidir.

Araştırma sonucunda öğretmenlerin STEM eğitimi ve uygulamalarına yönelik görüşlerinde meslekteki kıdem yıllarına göre anlamlı bir fark bulunmadığı belirlenmiştir.

Araştırma sonucunda öğretmenlerin STEM eğitimi ve uygulamalarına yönelik görüşleri ile mezun oldukları fakülte düzeyinde yapılan karşılaştırmada teknik bilgilerin yeterliliği maddesinde anlamlı bir fark bulunması öğretmenlerin STEM disiplinleri konusunda yeterlilikleri arasında fark olduğu ortaya çıkmıştır.

Araştırma sonucunda elde edilen veriler değerlendirildiğinde; günümüz bilgi ve teknoloji çağında eğitimde istenilen hedeflere ulaşılabilmesi için STEM eğitimi ve uygulamalarının okul öncesi eğitimde kullanılmasının kayda değer yararlar sağlayacağı düşünülmektedir.

ÖNERİLER

Okul öncesi eğitimin, çocuğun ileriki öğrenim hayatına etkisindeki sahip olduğu önem düşünüldüğünde okul öncesi eğitimde STEM eğitimi ve uygulamalarının daha etkin ve yaygın olarak kullanılması gerektiği düşünülmektedir. Ayrıca okul öncesi öğretmenlerinin bu alanlardaki bilgi, donanım ve yeterlilik düzeylerinin artırılması amacıyla uzman kişiler rehberliğinde hizmet içi eğitim kursları planlanmalı ve gerekli sıklıklarla uygulanmalıdır.

Çalışmanın, Kayseri ilinde pilot okul olarak belirlenen tek bir okuldaki sınırlı sayıda okul öncesi öğretmeniyle yürütülmüş olduğundan daha kapsamlı ve geniş bir örnekleme içeren çalışmalar yürütülmelidir. Çalışmanın bu alanda çalışacak araştırmalara rehberlik edecek pilot bir çalışma olduğu düşünülmektedir.

KAYNAKÇA

Çakar, E. Ve Üstün, E. (2006). Proje Yaklaşımının Okul Öncesi Dönem Çocuklarının Sosyal Gelişimlerine Ve Öğrenme Stillere Etkisinin İncelenmesi. *Marmara Üniversitesi Atatürk Eğitim Fakültesi. Bildiri Kitabı*. 1.Cilt s.44. İstanbul. Ya-Pa

Yaşar, Ş. (1993). Okulöncesi Eğitim Öğrencilerinde Fene Yönelik Duyuşsal Özellikler, 9. Ya-Pa Okulöncesi Eğitim ve Yaygınlaştırılması Semineri, Ankara, 140–142.

Kefi, S., & Çeliköz, N., & Erişen, Y.(2013). Okulöncesi Eğitim Öğretmenlerinin Temel Bilimsel Süreç Becerilerini Kullanım Düzeyleri, *Eğitim ve Öğretim Araştırmaları Dergisi Journal of Research in Education and Teaching* ,Cilt:2 Sayı:2 Makale No:34 ISSN: 2146-9199.

Kol, S., (2012). Okul öncesi eğitimde teknolojik araç-gereç kullanımına yönelik tutum ölçeği geliştirilmesi, *Kastamonu Eğitim Dergisi 543-554, cilt:20 No:2*, Sakarya Üniversitesi, Eğitim Fakültesi, Sakarya.

Akman,B., &Uyanık-Balat, G., &Güler, T.,(ed),(2011). Okulöncesi Dönemde Fen Eğitimi,.II,Basım, Pegem Akademi, Ankara.

Howe,J., (1975). Engaging children in sience, Colombus, Ohia, Second Edition.

Çavaş,B., Özdoğru,E., Kesercioğlu,T.(2012). Robot Kulübünün Öğrencilerin Bilimsel Süreç Becerileri, Bilimsel Yaratıcılık Beceri ve Robot, İnsan Toplum Algıları Üzerine Etkileri: X.Ulusal Fen Bilimleri ve Matematik Eğitimi Kongresi, Niğde.

Şahin,F.,(2006). Evde Anne Baba ile Fen Eğitimi. *Çoluk Çocuk Aylık Ana Baba ve Eğitimci Dergisi*. Sayı:63.s.3, Ankara, Kök Yayıncılık.

Merriam, S.B. (1988). *Case Study Research in Education, A Qualitative Approach*. USA San Francisco: Jossey-Bass Publishers.

5. SINIFLAR İÇİN GELİŞTİRİLEN BİLİMİN DOĞASI ETKİNLİLERİNİN ETKİLİLİĞİ

Menşure ALKIŞ KÜÇÜKAYDIN
TOKAT MEM/ Amasya Üniversitesi Sosyal Bilimler Enstitüsü Doktora Öğrencisi
mensurealkis@hotmail.com

Çiğdem AKKANAT
Amasya MEM/ Amasya Üniversitesi Fen Bilimleri Enstitüsü Doktora Öğrencisi
cmakkanat@gmail.com

Büşra BAKİOĞLU
TOKAT MEM/ Amasya Üniversitesi Fen Bilimleri Enstitüsü Doktora Öğrencisi
busra.durmus86@hotmail.com

Doç.Dr.Şafak ULUÇINAR SAĞIR
Amasya Üniversitesi Eğitim Fakültesi İlköğretim Bölümü
safak.ulucinar@amasya.edu.tr

Prof.Dr. Murat GÖKDERE
Amasya Üniversitesi Eğitim Fakültesi İlköğretim Bölümü
murat.gokdere@amasya.edu.tr

Doç.Dr.Orhan KARAMUSTAFAOĞLU
Amasya Üniversitesi Eğitim Fakültesi İlköğretim Bölümü
orhan.karamustafaoğlu@amasya.edu.tr

ÖZET: Bilimin doğası boyutuyla ilgili olarak yapılan gelişmeler kapsamında, konuyla ilgili literatür taranmış ve bilimin doğasını anlamaya yönelik etkinliklerin yeterli seviyede olmadığı görülmüştür. Bu amaçla 5.sınıf “Madde ve Değişim” ünitesi kapsamında yeni etkinlikler geliştirilmiş ve etkinliklerin etkililiği sınanmıştır. Çalışma Tokat il merkezine bağlı bir ortaokulda 5.sınıfta öğrenim gören iki sınıftan toplam 30 öğrenciyle gerçekleştirilmiştir.İlgili üniteye yönelik geliştirilen “Termoskoptan Termometreye”, “Tombala Oyunu” etkinlikleri ve literatürden“Bilim Çarkı” etkinliği deney grubuna uygulanmış, kontrol grubuna ise bilimin doğası kazanımları ders kitabı içeriği ile bütünleştirilerek sunulmuştur. Deney ve kontrol grubuna ön-son test olarak VNOS-E anketi uygulanmış, uygulanan anketler üç araştırmacı tarafından kodlanarak tutarlılık katsayısı 0,78 olarak hesaplanmıştır. Elde edilen bulgulara göre, deney grubunda bilimin doğasına yönelik görüşlerinin tamamında pozitif yönde bir değişme olmuş, iki grubun son test puanları arasında deney grubu lehine anlamlı fark bulunmuştur. Çalışma sonunda ilgililere gerekli ve uygulanabilir öneriler sunulmuştur.

Anahtar Kelimeler: Bilimin doğası, “Madde ve Değişim” ünitesi, 5. Sınıf Etkinlikleri, VNOS-E anketi

Abstract: Within the context of new findings about nature of science, literature has been reviewed and it was seen that the activities to develop nature of science understanding were not adequate. For this reason, new activities were developed as a part of 5th grade ‘Matter and Change’ unit and their effectiveness was tested. The research was conducted with 5th grade students from two classrooms, who were attending to a middle school in Tokat city center. Activities developed about the unit; ‘Thermoscope to Thermometer’, ‘Lotto Game’ and ‘Science Wheel’ activity from the literature were applied to experimental group with textbook content, as for control group the nature of science concepts were integrated with textbook content. VNOS-E questionnaire was conducted both for pretest and posttest to experimental and control group, the questionnaires were coded by three researchers and the coefficient of consistency was calculated as 0,78. Results indicated that, experimental group’s view of nature of science in all dimensions was changed in a positive way, a significant difference was found between the posttests of two groups in experimental group’s favor. As a result, essential and applicable suggestions were made for those who concerned.

KeyWords: Nature of Science, ‘MatterandChange’ unit, 5thgradeactivities, VNOS-E Questionnaire

GİRİŞ

Bilimsel gelişmelerin yoğun olarak yaşandığı günümüzde, birçok ülkede, fen eğitiminin nihai amacı, tüm bireylerin bilimsel okuryazarlığını geliştirmek olarak ifade edilmektedir. Bilimsel okuryazarlık, bireyin bilim ve teknoloji anlayışını gerektiren durumlarda sorumluluk gösteren kararlar vermesi ve bilişsel harekete geçebilmek için gerekli bilgi ve beceriye sahip olması olarak tanımlanmaktadır (Laugsksch, 2000). Küresel iklim değişikliği, enerji kaynakları, kök hücre araştırmaları ve modern tıptaki birçok gelişmelerle ilgili sosyobilimsel sorunlar sadece bilim insanlarını ve bu alanlarda çalışan diğer uzmanları değil, toplumun tüm bireyleri ilgilendiren konulardır. Bilimsel okuryazarlığı yüksek olan bireyler bu konularda fikir yürüterek süreçlere katılım gösterebilirler. Bu nedenle bilimsel okuryazarlığın geliştirilmesi ve bunun için ise bilimin doğasının anlaşılması önemlidir (Fowler, Zeidler&Sadler, 2009). Yenilenen fen bilimleri eğitim programında fen-teknoloji-toplum ve çevre öğrenme alanlarında sosyo-bilimsel konulara yönelik muhakeme yapma becerisine ve bilimin doğasını anlamaya yer verilmiştir (MEB, 2013). Araştırmacıların ortak bir tanımlaması olmaksızın bilimin doğası; McComas, Clough ve Almazroa (2002) tarafından, bilimin ne olduğu, nasıl çalıştığı, bilim insanlarının sosyal bir grup olarak nasıl çalıştıkları ve toplumun bilimsel çabaları nasıl yönlendirdiği ve nasıl tepki verdiği gibi konuların açıklanmasında; psikoloji gibi bilişsel bilimlerden araştırma ile bütünleştirilmiş bilim felsefesini, bilim tarihini ve bilim sosyolojisini içeren çeşitli sosyal bilimlerin bir karışımı olarak tanımlamışlardır. Fen eğitimcileri için ise bilimin doğasının; bilim felsefesi, bilim tarihi, bilim sosyolojisi ve bilim psikolojisinin fen öğretimi ve fen öğrenmeye uygulanırken ve onları potansiyel olarak etkilerken üzerine gittiği sorunların kesişmesini ifade ettiğini ve fen eğitimcilerine bilimi öğretmede yol gösteren temel yapıları olduğunu belirtmişlerdir. Bilim ve bilimin doğası üzerinde çalışan araştırmacılara göre bilimin doğası ile ilgili bahsedilmesi gereken özellikler: (1) Bilimsel bilginin değişebilir doğası, (2) Bilimsel bilginin deneye dayalı doğası, (3) Subjektiflik, (4) Bilimsel bilginin yaratıcı doğası, (5) Bilimsel bilginin sosyal ve kültürel yapısı, (6) Gözlemler, çıkarımlar, (7) Bilimsel teoriler ve başlıklar, (8) Bilimsel bilginin teori kökenli doğası, (9) Bilimsel yöntem miti olarak sıralamaktadır (Lederman, Abd-El-Khalick, Bell ve Schwartz, 2002). Bilimin doğası; bilimin ne olduğu ve hangi rolleri içerdiğini, bilim insanlarının kim olduğu ve hangi rolleri üstlendiklerini, bilimsel ipuçlarını, gözlemleri, olayları, kuralları, kanunları ve bilimsel yöntemi, bilimin nasıl yapıldığını anlamayı kapsamaktadır (Taşar, 2003).

Öğrencilerde bilimin doğası anlayışlarının geliştirmek üzere genel olarak üç yaklaşım vardır. Bunlar tarihsel, dolaylı ve doğrudan-yansıtıcı yaklaşımlardır. Araştırmalar bu üçü arasında en etkili yöntemin doğrudan-yansıtıcı yaklaşım olduğunu göstermektedir. Doğrudan-yansıtıcı yaklaşım birçok farklı gruba bilimin doğasını öğretmede etkili bulunmuş bir yaklaşım türüdür (Abd-el-Khalick&Lederman, 2000). Öğrencilerin erken sınıflarda bilimin doğası anlayışlarının geliştirilmesi, onların ilerleyen sınıflarda hem bilimin doğasını hem de fen ders içeriğini daha iyi anlamalarına yardımcı olabilir (Akerson, Buck, Donnelly, Nargund-Joshi&Weiland, 2011). Akerson ve Donnelly (2010) doğrudan-yansıtıcı yöntemin okul öncesi dönemdeki çocuklara bilimin doğasını öğretmede dahi başarılı bir yaklaşım olduğunu belirtmişlerdir. Akerson, Nargund-Joshi, Weiland, Pongsenon ve Avsar (2013) ilkökul üçüncü sınıf öğrencilerine (Amerikan eğitim sistemine göre 8 yaş grubu) doğrudan-yansıtıcı yaklaşımı bir öğretim yılı boyunca uygulamışlar ve etkili olduğunu görmüşlerdir. Doğrudan-yansıtıcı yaklaşıma dayalı bilimin doğası öğretimi sonucunda durumsal olarak seçtikleri üç öğrenciden düşük başarılı öğrencinin bilimin doğasını tartışabildiği, orta düzeyde başarılı öğrencinin bilimin doğasını tartışabildiği ve hakkında yazabildiği, yüksek başarılı öğrencinin ise bilimin doğası hakkında tartışabildiği, yazabildiği ve bilimin doğası ile ilgili sorular öne sürdüğü görülmüştür. Öğrencilerin bilimin doğasının daha somut olan boyutlarını (deneysel veriler ve gözlem ve çıkarım arasındaki fark gibi), bilimin doğası ile ilgili soyut fikirlere göre (öznel, yaratıcı ve değişebilir oluşu) daha kolay öğrendikleri görülmüştür. Bu nedenle Akerson ve ark. (2013) küçük yaşta öğrencilere bilimin doğası öğretilirken önce daha somut boyutlara daha sonra soyut boyutlara vurgu yapılması gerektiğini belirtmişlerdir.

Literatürde bilimin doğası ile ilgili çoğu araştırmada bilimin doğasının fen ders içeriğinden bağımsız olarak verildiği görülmüştür. Ayrıca ilkökul, ortaokul beşincisınıf ve okul öncesi dönem öğrencileriyle yapılan çalışmalar oldukça sınırlı sayıdadır. Bu çalışmada beşinci sınıf öğrencileri çalışma grubu olarak seçilmiş ve "Madde ve Değişim" ünitesine bütünleşmiş etkinliklerle doğrudan-yansıtıcı yaklaşım benimsenerek, öğrencilerin bilimin doğası hakkındaki görüşleri incelenmiştir. Bu araştırmanın örneklem olarak beşinci sınıf öğrencilerinin seçilmesi ve "Madde ve Değişim" ünitesine yönelik yeni bilimin doğası etkinlikleri içermesinden dolayı erken yaşta bilimin doğası öğretimi ile ilgili çalışmalara ışık tutacağı düşünülmektedir.

YÖNTEM

Araştırma Modeli

Araştırmada ön test son test kontrol gruplu yarı-deneysel yöntem kullanılmıştır. Uygulama yapılan okuldaki beşinci sınıf şubelerinden biri deney grubu, bir diğeri ise kontrol grubu olarak seçilmiş, çalışma öncesinde ve sonrasında her iki gruba da bilimin doğası hakkındaki görüşlerini belirlemek amacıyla bilimin doğası anketi uygulanmıştır.

Araştırmanın Örnekleme

Çalışma; Tokat iline bağlı merkez bir köyde bulunan bir ortaokulda öğrenim görmekte olan toplam 30 beşinci sınıf öğrencisi ile gerçekleştirilmiştir. Uygulama yapılan okulda iki tane beşinci sınıf şubesi bulunmaktadır. Şubelerde bulunan öğrencilerin sosyoekonomik düzeyleri, başarı ortalamaları ve aile profilleri eşit durumdadır. Bu öğrencilerin derslerine de yine aynı öğretmenler girmektedir. Çalışma kapsamında 15'er öğrenci içeren şubelerden seçkisiz olarak deney ve kontrol grupları belirlenmiştir. "Madde ve Değişim" ünitesi boyunca kontrol grubunda 5. sınıf Fen Bilimleri ders kitabında yer alan etkinlikler uygulanmış, bilimin doğası boyutları ile ilgili farklı bir etkinlik yapılmamıştır. Deney grubunda ise; araştırmacılar tarafından geliştirilen bilimin doğası etkinlikleri "Madde ve Değişim" ünitesinin öğretimi ile birleştirilerek doğrudan yansıtıcı yaklaşımla uygulamalar yapılmıştır. Çalışma yapılan her iki sınıfta da daha önceden bilimin doğası boyutları ile ilgili herhangi bir öğretim yapılmamıştır.

Veri Toplama Araçları

Çalışmada veri toplama aracı olarak Lederman ve Ko (2004) tarafından geliştirilen ve Erenoğlu (2010) tarafından literatürümüze kazandırılan VNOS-E anketi kullanılmıştır. Anketin içerdiği sorularla ilgili alt boyutlar aşağıdaki tabloda yer almaktadır.

Tablo 1. VNOS-E Ölçeğinin Alt Boyutları

Bilimin Doğası Boyutları	VNOS-E Soruları						
	1	2	3	4	5	6	7
Bilimsel bilgi güvenilir ama değişebilir	X		X	X		X	
Bilimsel bilgi mantıksal, matematiksel ve deneysel çıkarımlar içerir	X	X					
Bilimsel bilgi öznel dir	X				X		
Bilimsel bilginin elde edilmesinde hayal gücü ve yaratıcılığın önemli bir rolü vardır	X			X			X
Gözlem ve çıkarım farklı şeylerdir	X			X		X	

Kaynak: Seçkin, 2013; 34.

Uygulamalar

Araştırma, 5. sınıf öğrencileriyle Fen Bilimleri dersinde "Madde ve Değişim" ünitesinin öğretimi sırasında 5 hafta boyunca toplam 20 ders saatinde yürütülmüştür. Deney grubunda doğrudan yansıtıcı yaklaşımla bilimin doğası öğretilirken, kontrol grubunda Fen Bilimleri dersi öğretim programına bağlı kalınmış, ders kitabı içeriği dışında bilimin doğası ile ilgili doğrudan herhangi bir uygulama yapılmamıştır.

Deney Grubunda Kullanılan Etkinlikler

Araştırmada doğrudan yaklaşıma uygun olarak araştırmacılar tarafından geliştirilen "Termoskoptan Termometreye" adlı bir drama etkinliği ve "Tombala Oyunu" etkinliği ile birlikte literatürde yer alan "Kavram Çarkı ile Bilim" etkinliğinin konuya uyarlaması yapılarak uygulanmıştır. Araştırmacılar tarafından geliştirilen etkinlikler için uzman görüşü alınmış ve etkinlikler ders programına entegre edilerek kullanılmıştır. Tablo 2'de etkinlikler ve bu etkinliklerin yansıttığı bilimin doğasının boyutları verilmiştir. Ayrıca ilgili etkinliklere ait açıklamalar sunulmuştur.

Tablo 2. Hazırlanan Etkinliklerin Bilimin Doğası Boyutları

Bilimin Doğası Boyutları	Kullanılan Etkinlikler		
	Bilim Çarkı	Termoskoptan Termometreye	Tombala Oyunu
Bilimsel bilgi güvenilir ama değişebilir	X	X	
Bilimsel bilgi mantıksal, matematiksel ve deneysel çıkarımlar içerir	X	X	X
Bilimsel bilgi öznel dir		X	
Bilimsel bilginin elde edilmesinde hayal gücü ve yaratıcılığın önemli bir rolü vardır	X		
Gözlem ve çıkarım farklı şeylerdir	X		X

Kavram Çarkı ile Bilim: Öğrencilerin bilim, bilim insanı ve bilimsel bilgi ile ilgili fikirlerini ortaya çıkarmayı amaçlayan bir etkinliktir (Doğan, Çakıroğlu, Bilican ve Çavuş, 2010). Etkinlik uygulanırken öğrencilerin maddenin halleri ile ilgili sınıfta uygulanan deneylerden gözlem ve çıkarımlara ulaşmaları beklenmektedir. Etkinlikte öğrencilerin verdikleri cevaplarla tahtaya bir bilim çarkı oluşturulmuştur.

Tombala Oyunu:Öğretmen sınıftan önceden belirlediği altı öğrenci seçer ve öğrencilerin birbirini görebileceği biçimde sınıfta oturma düzenlemesi yapar. Ardından hazırlanan tombala kartonlarını seçilen öğrencilere verir. Başka bir öğrenci daha seçerek ona da içinde renkli kartonların bulunduğu poşet verir. Poşetin içinde Genleşme, Büzülme, Kaynama, Yoğunlaşma ve Süblimleşme kavramlarını temsil edecek resimler bulunmaktadır. Her bir öğrenci hangi kavramı temsil ediyorsa o öğrenci tombala poşetinden çıkan resmi alır ve oyununu oynar. Öğretmen bu esnada, diğer öğrencilere arkadaşlarını gözlemlenmelerini ve hangi arkadaşlarının hangi kavramı temsil ettiğini bulmalarını ister. Gözlem ve ardından çıkarımlarını açıklamalarını ister.

Termoskoptan Termometreye:Drama, okuma parçası ve tartışmalardan oluşan bir etkinliktir. Etkinlikte öncelikle öğrencilere evde çalışmaları için drama etkinlikleri verilir, termometrenin yapımını araştırmaları istenir. Yapacakları deneylerde kullanılacak malzemeler önceden temin edilir. Daha sonra içinde sıcak su bulunan şişe ucuna geçirilen balonun şişmesi deneyi yapılır. Öğrencilerin havanın genleştiğinde hacminin arttığı sonucuna ulaşmaları beklenir. “Termoskoptan Termometreye” okuma parçası okutulur ve ardından drama etkinliğine geçilir. Drama; Galileo ve onunla birlikte Viyana’da yaşayan arkadaşları SantorioSantorio ve GianFrancescoSagredo arasında geçen bir konuşmaya dayanmaktadır. Konuşmaların ardından o dönemde yapılan icadın eksikliklerinden bahsedilmekte ve modern termometreye geçiş ihtiyacı vurgulanmaktadır.

Verilerin Analizi

Deney ve kontrol gruplarına bilimin doğası anketi ön ve son test olarak uygulanmıştır. Uygulanan testler üç araştırmacı tarafından okunarak yanlış cevap, yetersiz; kısmen yeterli cevap, uygun; istenen düzeyde verilen cevaplar modern görüş olarak kodlanmış ve sırasıyla 0, 1 ve 2 şeklinde puanlandırılmıştır. Çalışmada kodlayıcı tutarlılığı 0,78 olarak hesaplanmıştır. Öğrenci cevaplarının betimsel analizi yapılarak bilimin doğası boyutlarındaki değişim ön test ve son test sonuçlarının karşılaştırılması ile tespit edilmeye çalışılmıştır.

BULGULAR

Deney ve kontrol gruplarına uygulanan bilimin doğası anketininön ve son test puanlarının betimsel analizi Tablo 3’de verilmiştir.

Tablo 3. Grupların Ön- Son Test Puanlarının Bilimin Doğası Alt Boyutlarına Göre Betimsel Analizi

Grup	1		2		3		4		5		6		7										
	0	1	2	0	1	2	0	1	2	0	1	2	0	1	2								
Ön test	Deney	n	12	2	1	13	2	0	7	8	0	8	6	1	11	4	0	10	4	1	5	10	0
		%	80	13	7	87	13	0	47	53	0	53	40	7	73	27	0	67	27	7	33	67	0
	Kontrol	n	12	2	1	14	1	0	8	6	1	4	10	1	12	3	0	15	0	0	5	10	0
		%	80	13	7	93	7	0	53	40	7	27	67	7	80	20	0	100	0	0	33	67	0
Son test	Deney	n	6	7	2	3	12	0	3	8	4	7	4	4	7	5	3	7	4	4	2	10	3
		%	40	47	13	20	80	0	20	53	27	47	27	27	47	33	20	47	27	27	13	67	20
	Kontrol	n	12	3	0	5	10	0	4	9	2	12	2	1	11	4	0	11	4	0	6	8	1
		%	80	20	0	33	67	0	27	60	13	80	13	7	73	27	0	73	27	0	40	53	7

0: Yetersiz 1: Uygun 2: Modern görüş

Grupların öntestte sorulara verdikleri cevaplar kategoriler bazında incelendiğinde yaklaşık olarak her iki grubun benzer puanlar aldığı görülmüştür. Son test puanlarına bakıldığında yetersiz cevaplardaki yüzdelerdeki değişimin deney grubunda tüm sorularda düşüş, kontrol grubunda 4. soruda ve 7. soruda artış şeklinde olduğu görülmüştür. Uygun görüşlerin oranı deney grubunda 1-2 ve 5. soru için artış göstermiş, 3-6 ve 7. sorularda değişmemiş; 4. soruda azalmıştır. Kontrol grubunda ise 4. ve 7. soruda azalma diğerlerinde artma olmuştur. Modern görüşlerde ise deney grubunda 2. soruda değişme olmazken diğer sorularda artış olmuştur; kontrol grubunda ilk soruda azalma, 3 ve 7.soruda artma ve diğerlerinde değişme olmamıştır.

Bilimin doğası boyutlarına göre son test puanları “Bilimsel bilgi güvenilirdir ama değişebilir” boyutu için 1, 3, 4, 6. sorularda incelendiğindeöğretim sonrasında deney grubunda uygun ve modern görüşler birinci soruda %40 (%20’den %60’a), 3. soruda %27 (53’ten 80’e), 4. soruda %7 (47’den 54’e) ve 6.soruda %20 (34’ten 54’e) yükselmiştir. Kontrol grubunda ise sırasıyla sorulardaki değişim yüzdeleri 0, 26, -44 ve 7 oranındadır. “Bilimsel bilgi mantıksal, matematiksel ve deneysel çıkarımlar içerir” boyutuyla ilgili olan 1. ve 2. soruya verilen cevaplar yetersiz görüşlerin uygun görüşe büyük oranda dönüştüğü (2. soruda uygun görüş deney grubunda %13 ten %80’e, kontrol grubunda %7’den %67’ye),deney ve kontrol grubunda değişim yüzdelerinin 67 ve 60 olduğu görülmüştür. “Bilimsel bilgi öznel” boyutuyla ilgili olan 1 ve 5. sorudan 5. Soru için uygun ve modern görüşlerin toplamındaki değişim %26 deney grubunda %7 kontrol grubundadır.“Bilimsel bilginin elde edilmesinde hayal gücü ve yaratıcılığın önemli bir rolü vardır” boyutunda yer alan 1.,4. ve 7. Sorular incelendiğinde 7. soruda değişimin deney grubunda %20 kontrolde %3 olduğu görülmüştür. Son boyut olan

“Gözlem ve çıkarım farklı şeylerdir” 1., 4. ve 6. soruları içermektedir ki birinci alt boyutla aynı değerlerde sırasıyla yüzde 40, 7 ve 20 deney grubu lehine artış gözlenmiştir.

Bilimin doğasıyla ilgili tüm boyutlarda deney grubunun puan artığının fazla olduğu görülmektedir. “Bilimsel bilgi güvenilir ama değişebilir” ,“Bilimsel bilginin elde edilmesinde hayal gücü ve yaratıcılığın önemli bir rolü vardır”,“Bilimsel bilgi özeldir” “Gözlem ve çıkarım farklı şeylerdir” boyutlarında değişim daha fazladır.

Deney ve kontrol grubunun ön test ve son test puanlarının karşılaştırılmasında hangi tür istatistiksel analizi yapılacağını belirlemek için verilerin normal dağılım gösterip göstermediği Kolmogorov –Smirnov testi ile kontrol edilmiştir. Kontrol grubu için ön test değerleri K –S z=0,599 p=0,866 ve son test z=0,527 p= 0,944 bulunmuştur. Deney grubu için K-S z=0,778 p=0,580 ve son test z=0,672 p=0,757 bulunmuştur ki p|>0,05 verilerin normal dağılımını göstermektedir. Parametrik testler uygulanabilir (Pallant, 2005)

Grupların ön ve son test puanlarının karşılaştırılması için yapılan ilişkisiz örneklem t testi sonuçları Tablo 4’te verilmiştir.

Tablo 4.Ön ve son test puanlarına ait t testi sonuçları

	Gruplar	N	\bar{X}	S	sd	t	p
Öntest	Kontrol	15	2,53	1,73	28	-0,344	0,733
	Deney	15	2,80	2,45			
Sontest	Kontrol	15	3,20	2,21	28	-2,365	0,025*
	Deney	15	6,00	4,02			

Tablo 4’den de görüleceği üzere öğrencilerin ön test puanları arasında anlamlı farklılık yoktur ($t=-0,344, p>0,05$). Buna göre etkinlikler yapılmadan önce bilimin doğası hakkındaki görüşler bakımından iki grubunda birbirine benzer olduğu söylenebilir. Ünitenin bitiminde bilimin doğası ile ilgili etkinlikler ek olarak deney grubunda uygulandıktan sonra son test puanları arasında anlamlı farklılık bulunmuştur ($t=-2,365, p<0,05$). Bu bilimin doğasına yönelik yapılan etkinliklerin öğrencilerin bilimin doğası hakkındaki görüşlerini geliştirmede etkili olduğunu göstermektedir. Hesaplanan etki büyüklüğü (etki büyüklüğü: $\eta^2=0,2$) oldukça geniştir (Büyüköztürk, 2012). Buna göre bilimin doğasında görülen varyansın yaklaşık %20’sinin uygulanan etkinliklerden kaynaklandığı söylenebilir.

Kontrol grubunda sadece programda yer alan etkinlikler uygulanmıştır. Her ne kadar programda bilimin doğasının öğretimine vurgu yapılırsa da, bunun uygun etkinlik ve yaklaşımlarla yeterince desteklenmediği açıktır. Bu durumda, bilimin doğasına yönelik aktivitelerin kullanımının, bu tür aktivitelerin kullanılmadığı ders işleyişine göre anlamlı düzeyde etkili olduğu ileri sürülebilir.

TARTIŞMA

Bu çalışmada 5. sınıf öğrencilerinin bilimin doğasını anlayışlarını geliştirmek amacıyla hazırlanan etkinliklerin uygulanması sonucunda, öğrencilerin bilimin doğası hakkındaki görüşlerinde meydana gelen değişimler incelenmiştir. Deney grubunda ders kitabındaki etkinliklerin yanında farklı etkinlikler uygulanmış, kontrol grubunda ise fen bilimleri öğretim programına uygun olarak kullanılan 5. sınıf Fen Bilimleri ders kitabındaki etkinlikler dışında herhangi bir etkinlik uygulanmıştır. Uygulanan etkinlikler sonucunda; deney grubunun bilimin doğası anketi puanlarında anlamlı farklılık olduğu görülmüş ancak kontrol grubunun puanlarında anlamlı bir farklılık görülmemiştir (Tablo 4). Çeşitli etkinliklerin uygulanması yoluyla erken yaşlarda bilimin doğası anlayışlarının geliştirilebileceğine yönelik bu bulguyu destekleyen araştırmalar mevcuttur (Akerson ve ark., 2011; Can ve Şahin Pekmez, 2010; Erenoğlu, 2010).

Kontrol grubundaki öğrencilerin puanları incelendiğinde 3. (bilimsel bilginin değişebilir) ve 7. (hayal gücü ve yaratıcılığın rolü) soruda yetersiz görüşlerde artış olduğu görülmüştür. Bu durum fen dersinde kitaba dayalı yapılan öğretimin bu sonuca yol açmış olabileceğini akla getirmektedir. Özellikle bilimsel bilgilerin değişebilir doğası ile ilgili olarak öğrencilerin görüşlerini %50 oranında yetersize görüşe doğru değiştiği görülmektedir. Bunun nedeni anket uygulandıktan sonra öğrencilere anketteki soruların cevapları hakkında uygulamadan dolayı bir dönüt verilmemesi, öğrencilerin kendi aralarında ankette verdikleri cevaplar hakkında konuşmaları ve sonuçta da öğrencilerin verdikleri cevaplardan emin olamayıp görüş değişikliğine gitmeleri olabilir. Öğrencilerin görüşlerini etkileyecek bir başka neden olarak da fen bilimleri ders kitabında yer alan ifadelerin genellikle bilimsel bilginin kesinliğine işaret edecek biçimde yazılması gösterilebilir. Ancak kontrol grubundaki gibi sadece ders kitabındaki etkinliklere ve programdaki yaklaşıma bağlı olarak gerçekleştirilen öğretimin yenilenen fen bilimleri programında öngörüldüğü gibi bilimin doğası hakkındaki görüşleri geliştirmede yeterli olmadığı açıktır.

Deney grubundaki öğrencilerin bilimin doğası anlayışları farklı boyutlar açısından ele alındığında ise genel olarak tüm boyutlarda puan artışı olduğu ve yetersiz görüşlerin uygun ya da modern görüşlere doğru değiştiği gözlenmiştir. Bu durum uygulanan etkinliklerin beklenen düzeyde etkili olduğunu göstermektedir. Ancak en az puan artışının ‘Bilimsel bilgi mantıksal, matematiksel ve deneysel çıkarımlar içerir’ boyutunda olduğu görülmüştür. Etkinliklerde bu boyuta yer verilmesine rağmen gözlenen gelişimin az olmasının nedeni çıkarım yapmanın öğrencilere fazla soyut gelmesi olabilir. Bu çalışmada uygulanan etkinliklere ek olarak ünite ile ilgili kazanımları göz ardı etmeden, matematiksel işlem ve ifadelerle yer verilen bir etkinliğe ya da deneye yer vermek bu boyutta görüşlerin daha çok geliştirilmesinde etkili olabilir. Bu boyutla ilgili olan anket sorularında öğrencilere bilimin tanımı ve bilimi diğer alanlarda farklı kılan özellikler sunulmuştur. Öğrenciler genellikle bilimi sadece sınıfta gördükleri fen dersleriyle ilişkilendirdiklerinden, ders bazında düşünüp ayırım yapmakta zorlanmış olabilirler. Bir başka neden ise bu boyutla ilgili soru sayısının görece olarak daha az olmasıdır. Öğrencilerin görüşlerini açığa çıkarmada her boyutla ilgili daha fazla soru sorulması geçerliliği artırabilir. Soru bazında bakıldığında ise yetersiz görüşlerin, uygun ve modern görüşlere değişiminin görece olarak en az olduğu soru 6. sorudur. Bu soruda öğrencilere meteoroloji uzmanlarının hava durumu ile ilgili verdikleri bilgilerin kesinliği hakkında yorum yapmaları beklenmiştir. Soru, gözlem ve çıkarım yapma boyutları ve bilimsel bilginin değişebilir olduğu ile ilgilidir. Etkinliklerde bu boyutlara yer verilmesine rağmen öğrenciler bu soruda yorum yapmada oldukça zorlanmışlardır. Bunun nedeni öğrencilere geçmiş öğrenimleri boyunca iklim ve hava durumu ile ilgili verilen bilgiler olabilir. Ayrıca 5. sınıf öğrencileri genellikle iklimi ve hava olaylarının hava durumu ile karıştırma eğilimindedir ve bu konularla ilgili kavram yanlışlarına sahiptir. (Henriques, 2000; Doğan ve Başbüyük, 2005). Bu da onların bu soruda doğru çıkarımlar yapmalarını engellemiş olabilir. Özellikle 5. sınıf düzeyinde bu boyuttaki görüşler öğrencilerin kavramada zorluk çekmediği bir konu ile ilgili olursa, öğrencilerden daha yüksek oranda uygun ve modern görüşler alınabilecektir.

SONUÇ VE ÖNERİLER

Bilimin doğası boyutuyla ilgili olarak yapılan gelişmeler kapsamında bilimin doğasını anlamaya yönelik etkinliklerin yeterli seviyede olmadığı düşünülerek 5.sınıf “Madde ve Değişim” ünitesi kapsamında yeni etkinlikler geliştirilmiş ve etkinliklerin etkililiği sınanmıştır. Araştırma bulgularından deney grubu öğrencilerinin, kontrol grubu öğrencilerine göre VNOS-E ölçeğinden daha yüksek puanlar aldığı belirlenmiştir. Bu doğrultuda, oluşturulan etkinlikler sayesinde deney grubu öğrencilerinin bilimin doğasını anlama konusunda kontrol grubu öğrencilerine göre daha fazla ilerleme gösterdiği tespit edilmiştir. Ayrıca, her iki grubun ön test – son test puanları kendi içinde incelendiğinde; her iki grubun da bilimin doğasını anlama becerilerinin arttığı, bu nedenle de her iki öğretimin (bilimin doğası etkinlikleri ve programdaki öğretimin) öğrencileri üzerinde bilimin doğasını anlamalarına katkı sağladığı söylenebilir. Gerçekleştirilen bu çalışmanın ışığında şu öneriler sunulabilir;

- Bilimin doğasını öğrencilerin anlaması için ders kitaplarına bu ve bunlara benzer etkinlikler yerleştirilmeli ve işlenen üniteye bu etkinlikler entegre edilmelidir.
- Fen ve Teknoloji/Fen Bilimleri öğretmenleri farklı üniteler işlerken ve farklı sınıflarda eğitim-öğretim yaparken bu etkinliklerden faydalanabilir.
- Alan araştırmacıları, hazırlanan bu etkinliklerle farklı sınıf seviyelerinde alan araştırması yapabilirler.
- Öğretmen adaylarına bilimin doğası etkinliklerinin nasıl hazırlanacağına ilişkin dersler verilebilir.
- Fen ve Teknoloji/Fen Bilimleri öğretmenlerine bilimin doğası etkinliklerinin nasıl hazırlanacağına yönelik hizmet içi seminerler düzenlenebilir.

KAYNAKLAR

Abd-El-Khalick, F. & Lederman, N. (2000). Improving Science Teachers’ Conceptions of Nature of Science: A Critical Review of The Literature, *International Journal of Science Education*, 22(7), 665-701.

Akerson, V.L. & Donnelly, L.A. (2010). Teaching Nature of Science to K-2 Students: What Understandings Can They Attain? *International Journal of Science Education*, 32, 97-124.

Akerson, V.L., Weiland, I.S., Pongsanon, K., & Nargund-Joshi, V. (2011). Evidence Based Strategies for Teaching Nature of Science to Young Children., *Journal of Kırşehir Education*, 11(4), 61-78.

Akerson, V., Nargund-Joshi, V., Weiland, I., Pongsanon, K. & Avsar, B. (2013). What Third-Grade Students of Differing Ability Levels Learn About Nature of Science After a Year of Instruction, *International Journal of Science Education*, 1-33.

Altındağ, C., Tunç Şahin, C. & Saka, Y. (2012). Bilimin Doğası Öğretimine Yönelik Etkinlik Örneği. *Araştırma Temelli Etkinlik Dergisi (ATED)*, 2(1), 1-9.

- Büyüköztürk, Ş. (2012) .Sosyal Bilimler İçin Veri Analizi El Kitabı: İstatistik, araştırma deseni, SPSS uygulamaları ve yorum(16. Baskı). Pegem Akademi, Ankara
- Can, B. & Şahin Pekmez E. (2010). Bilimin Doğası Etkinliklerinin İlköğretim Yedinci Sınıf Öğrencilerinin Bilimsel Süreç Becerilerinin Geliştirilmesindeki Etkisi. *Pamukkale Üniversitesi Eğitim Fakültesi Dergisi*. 27, 113-123.
- Doğan, N., Çakıroğlu, J. ,Bilican, K. & Çavuş, S. (2012). Bilimin Doğası ve Öğretimi, Pegem Akademi, Ankara.
- Doğar, Ç. ve Başbüyük, A. (2005). İlköğretim ve Ortaöğretim Öğrencilerinin Hava ve İklim Olaylarını Anlama Düzeyleri. *Kastamonu Eğitim Dergisi*, 13(2), 347-358.
- Erenoğlu, C.(2010) Doğada Fen Öğretiminin 5.Sınıf Öğrencilerinin Bilimin Doğası Anlayışlarına Etkisi, Yayınlanmamış Yüksek Lisans Tezi, Ege Üniversitesi Sosyal Bilimler Enstitüsü, İzmir.
- Fowler, S.R.,Zeidler, D.L. &Sadler, T.D. (2009). Moral Sensitivity in TheContexSocioscientificIssues in High SchoolScienceStudents, *International Journal of ScienceEducation*, 279-29.
- Henriques, L. (2000). Children'smisconceptionsaboutweather: a review of theliterature. *TheAnnual Meeting of theNationalAssociation of Research in ScienceTeaching*,<http://www.csulb.edu/~lhenriqu/NARST2000.htm>.
- Lederman, J. S. &Ko, E. K. (2004). *Views of nature of science, Form E*. UnpublishedPaper. Illinois Institute of Technology, Chicago.
- Lederman, N. G.,Abd-El-Khalick, F., Bell, R. L., ve Schwartz, R. S. (2002). Views of Nature of ScienceQuestionnaire: TowardValidandMeaningfulAssessment of Learners' Conceptions of Nature of Science. *Journal of Research in ScienceTeaching*, 39 (6), 497-521.
- Laugksch, R. (2000)*ScientificLiteracy: A conceptualOverview*, *ScienceEducation*, 84 (1), 71–94.
- McComas, W.F.,Clough, M.P., &Almazroa, H. (2002). The role andcharacter of thenature of science in scienceeducation. In W.F. McComas (Ed.), *Thenature of science in scienceeducation: Rationalesandstrategies* (pp.3-39). Dordrecht, theNetherlands: KluwerAcademicPublishers
- Pallant, J. (2005). SPSS Survival Manual (Second Edition).Sydney: Allen&Unwin.
- Seçkin, M.(2013) Sekizinci Sınıf Öğrencilerinin Bilimin Doğası hakkındaki Görüşlerinin Belirlenmesi, *Eğitim ve İnsani Bilimler Dergisi*, 4(7), 27-52.
- Taşar, M. F. (2003)TeachingHistoryandThe Nature of Science in ScienceTeacherEducationPrograms,*Pamukkale Üniversitesi Eğitim Fakültesi Dergisi*, 13(1), 30-42.

ÖĞRETMEN ADAYLARININ BİLİMSEL EPİSTEMOLOJİK İNANÇLARINDAKİ DEĞİŞİM ÜZERİNE KARŞILAŞTIRMALI BİR ÇALIŞMA

Fatih KARAKUŞ
Afyon Kocatepe Üniversitesi
fkarakus@aku.edu.tr

Bülent AYDOĞDU
Afyon Kocatepe Üniversitesi
baydogdu@aku.edu.tr

ÖZET: Bu çalışmanın amacı, öğretmen eğitimi programında yer alan bilimsel araştırma yöntemleri dersi ile bu dersi alan ve aynı zamanda farklı bilimsel araştırmaları inceleyen ilköğretim matematik öğretmenleri adaylarının bilimsel epistemolojik inançlarındaki değişimi incelemektir. Çalışma ön-test son test üç gruplu (iki deney bir kontrol) yarı-deneysel araştırma modeline göre yürütülmüştür. Araştırmada deney gruplarından biri (Deney-1) hem bilimsel araştırma yöntemleri dersini hem de beş farklı yüksek lisans ve doktora tezini incelemiş, diğer bir grup (Deney-2) sadece bilimsel araştırma yöntemleri dersini almış, son grup (Kontrol) ise ne bilimsel araştırma yöntemleri dersini almış ne de herhangi bir bilimsel çalışmayı incelememiştir. Çalışmanın örneklemini ülkemizin Ege bölgesindeki bir eğitim fakültesi ilköğretim sınıf öğretmenliği bölümünde okuyan 99 öğretmen adayı oluşturmaktadır. Veri toplama aracı olarak Pomeroy (1993) tarafından geliştirilen ve Deryakulu ve Bıkmaz (2003) tarafından Türkçe'ye uyarlanan "Bilimsel Epistemolojik İnançlar Ölçeği" kullanılmıştır. Elde edilen sonuçlar her bir gruptaki öğretmen adaylarının bilimsel epistemolojik inanç ölçeğinden aldıkları ön test ve son test puan ortalamaları arasında istatistiksel olarak anlamlı bir farklılığın olmadığını göstermektedir. Buna karşın her üç grubun son test puan ortalamaları karşılaştırıldığında ise Deney-1 ve Deney-2 lehine anlamlı bir farklılığın olduğu belirlenmiştir. Bu durum farklı bilimsel çalışmalarını incelemenin ve bilimsel araştırma dersinin öğretmen adaylarının epistemolojik inançlarının geleneksel olmayan inanca doğru bir değişime neden olduğunu göstermektedir.

Anahtar sözcükler: İnanç, epistemolojik inanç, bilimsel epistemolojik inanç, öğretmen adayları, inançlardaki değişim

ABSTRACT: The aim of this study was to examine the effects of both scientific research method course and investigating different scientific research papers on the pre-service teachers' scientific epistemological beliefs. A quasi-experimental statistical design (two experimental groups and one control group) was used in the study. One of the experimental groups (Deney-1) took both scientific research method course and investigated five different research papers and other group (Deney-2) took only scientific research method course. The control group (Kontrol) took neither scientific research method course nor investigates research papers. The sample under investigation was comprised of 99 pre-service teachers from a university in the Aegean region of Turkey. In order to determine pre-service teachers' scientific epistemological beliefs the "The Scientific Epistemological Beliefs Survey" developed by Pomeroy (1993) and adapted to Turkish by Deryakulu and Bıkmaz (2003) was used. The finding showed that there was no any statistically meaningful difference between pre-service teachers' pre-test and post-test scientific epistemological beliefs scores. Moreover, comparing the post-test scores of the groups, there was a statistically meaningful difference in favor of both Deney-1 and Deney-2. This shows that both scientific research method course and investigating different scientific research papers had an effect on the pre-service teachers' scientific epistemological beliefs.

Keywords: Beliefs, epistemological beliefs, scientific epistemological beliefs, pre-service teachers, changing beliefs.

GİRİŞ

Bilim, olgular hakkında gözleme, deneye, akla dayanarak sistematik yollarla elde edilen bilgileri içermektedir. Bilimsel bilginin elde edilmesinde problemin fark edilmesi, problemin tanımlanması, çözüm önerilerinin tahmini, araştırma yöntemlerinin geliştirilmesi, verilerin toplanması ve analizi ile karar verme ve yorumlama aşamaları takip edilmektedir. Bu bağlamda bilimsel yöntemler betimleme ve açıklama yollarını içeren eylemsel ve aynı zamanda düşünsel süreçlerdir (Büyüköztürk, Çakmak, Akgün, Karadeniz ve Demirel, 2013). Bilginin ne olduğunu ve bireyin nasıl bildiği konusu epistemolojinin alanına girmektedir. Bireyin bilginin doğası ve bilginin

öğrenilmesine yönelik inançları epistemolojik inançlar olarak adlandırılmaktadır (Hofer & Pintrich, 1997). Epistemolojik inançlar, özellikle bilginin tanımı, bilginin yapılanması, bilginin değerlendirilmesi, bilginin konumu ve bilginin oluşumu hakkındaki inançları içermektedir. Bu bağlamda bilimsel epistemolojik inançlar ise, bireyin bilimin ne olduğu, özellikleri, yöntemleri, oluşumu ve bilimin nasıl öğretilmesine yönelik inançlarını kapsamaktadır (Deryakulu & Bıkmaz, 2003). Bilimsel epistemolojik inançlara yönelik ilgi, geleneksel pozitivist bilim anlayışından, bireyi merkeze alan ve bireyin yaşadığı kültürün, inançların, değerlerin ve sezgilerin bilimsel araştırma sürecindeki önemini ve gerekliliğini vurgulayan post modern bilim anlayışına geçişin bir sonucu olarak ortaya çıktığı ifade edilmektedir.

Bilimsel epistemolojik inançların öğrenci ve öğretmenlerin öğrenme ve öğretme yaklaşımları, öğrenme ortamları, kullandıkları öğrenme stratejileri ve algılayma ve yorumlama biçimleri üzerindeki etkilerini inceleyen çalışmalara rastlanmaktadır (bkz. Richardson, Anders, Tidwell, & Lloyd, 1991; Brownlee, Tickle & Nailon, 2004). Bu durum etkili öğretim uygulamalarının tasarlanmasında öğretmen ve öğrencilerin bilimsel epistemolojik inançlarının oldukça önemli olduğunu göstermektedir. İnançlar geçmiş deneyimlerimiz sonucunda oluşur ve öğrenim hayatımız boyunca şekillenir. Öğretmen adayları mesleki gelişimlerine katkıda bulunacak bilimsel araştırmaları inceleyebilme, eleştirebilme ve bağımsız araştırma yapabilme yeterliliklerini geliştirmeye yönelik bilimsel araştırma yöntemleri ve araştırma projesi gibi dersleri öğretmen eğitimi programlarında almaktadırlar. Dolayısıyla bu derslerin öğretmen adaylarının bilimsel epistemolojik inançları üzerindeki etkilerinin incelenmesi önemlidir.

Çalışmanın amacı, öğretmen eğitimi programında yer alan bilimsel araştırma yöntemleri dersi ile bu dersi alan ve aynı zamanda farklı bilimsel araştırmaları inceleyen ilköğretim matematik öğretmeni adaylarının bilimsel epistemolojik inançlarındaki değişimi incelemektir.

YÖNTEM

Bu araştırma ön-test son test üç gruplu (iki deney bir kontrol) yarı-deneysel araştırma modeline göre yürütülmüştür. Araştırmada deney gruplarından biri (Deney-1) hem bilimsel araştırma yöntemleri dersini hem de beş farklı yüksek lisans ve doktora tezini incelemiş, diğer bir grup (Deney-2) sadece bilimsel araştırma yöntemleri dersini almış, son grup (Kontrol) ise ne bilimsel araştırma yöntemleri dersini almış ne de herhangi bir bilimsel çalışmayı incelememiştir. Öğretim her üç grupta da araştırmacılarından biri tarafından yürütülmüştür. Araştırmacıların yarı-deneysel araştırma modelini seçmelerinin nedeni bu modelin araştırmacılara bağımlı ve bağımsız değişkenler arasında neden-sonuç ilişkisi kurmasına izin vermesidir (Creswell, 2012).

Örneklem

Çalışmanın örneklemini ülkemizin Ege bölgesindeki bir eğitim fakültesi ilköğretim sınıf öğretmenliği bölümünde okuyan 99 öğretmen adayı oluşturmaktadır. Bu öğretmen adaylarından 36'sı Deney-1 grubunda, 31'i Deney-2 grubunda ve 32'si de Kontrol grubunda yer almaktadır.

Veri toplama aracı

Veri toplama aracı olarak Pomeroy (1993) tarafından geliştirilen ve Deryakulu ve Bıkmaz (2003) tarafından Türkçe'ye uyarlanan "Bilimsel Epistemolojik İnançlar Ölçeği" kullanılmıştır. Ölçek 5'li likert türünde olup 30 maddeden ve tek faktörden oluşmaktadır. Ölçeğin güvenirlik katsayısı (Cronbach Alfa) .91 olarak bulunmuştur. Ölçekte yer alan 30 maddenin geleneksel bilim anlayışını yansıtan 22 maddesi olumlu, geleneksel olmayan bilim anlayışını yansıtan 8 maddesi ise olumsuzdur. Bu anlamda ölçekten alınan yüksek puan geleneksel bilim anlayışına, düşük puan ise geleneksel olmayan bilim anlayışına yönelik inancı göstermektedir.

Verilerin analizi

Öğretmen adaylarının epistemolojik inanç ölçeğinden aldıkları ön-test ve son-test puanlarının aritmetik ortalamaları hesaplanmış ve sahip oldukları inanç düzeyleri Tekin'in (1996) formülü kullanılarak "1,00 - 1,79 = Kesinlikle Katılmıyorum", "1,80 - 2,59 = Katılmıyorum", "2,60 - 3,39 = Kararsızım", "3,40 - 4,19 = Katılıyorum" ve "4,20 - 5,00 = Kesinlikle Katılıyorum" şeklinde düzenlenmiştir. Deney ve Kontrol grubundaki öğretmen adaylarının epistemolojik inanç ölçeğinden aldıkları ön-test puanları arasında istatistiksel olarak anlamlı bir farklılığın olup olmadığını belirlemek için ($\alpha = .05$) tek yönlü varyans analizi ANOVA yapılmıştır. Daha sonra her bir grup için epistemolojik inanç ölçeğinden aldıkları ön-test ve son-test puanları arasında istatistiksel olarak anlamlı bir farklılığın olup olmadığını belirlemek için ($\alpha = .05$) paired sample t-testi yapılmıştır. Son olarak grupların ön-test puanları kontrol altına alınarak grupların epistemolojik inanç

ölçeğinden aldıkları son-test puanları arasında istatistiksel olarak anlamlı bir farklılığın olup olmadığını belirlemek için ($\alpha = .05$) kovaryans analizi (ANCOVA) yapılmıştır.

BULGULAR

Deney ve Kontrol grubundaki öğretmen adaylarının ön-test ve son-test puanlarına ait betimsel istatistik sonuçları Tablo 1’de sunulmuştur.

Tablo 1. Bilimsel Epistemolojik İnanç Ölçeğinden Alınan Ön-Test Ve Son-Test Puanlarına İlişkin Betimsel İstatistik Sonuçları

Grup	Ön-test			Son-test		
	N	\bar{X}	S.S	N	\bar{X}	SS
Deney-1	36	2,78	,252	36	2,73	,239
Deney-2	31	3,23	,284	31	3,14	,343
Kontrol	32	3,32	,345	32	3,32	,222

Tablo 1’den her üç gruptaki öğretmen adaylarının ön-test puan ortalamalarına göre bilimsel epistemolojik inançlarının “kararsızım” seviyesinde olduğu görülmektedir. Bu grupların son-test puan ortalamalarına göre bilimsel epistemolojik inançlarının ise yine “kararsızım” seviyesinde olduğu görülmektedir. Bu durum bilimsel araştırma yöntemleri dersi ile farklı bilimsel araştırmaları incelemenin öğretmen adaylarının bilimsel epistemolojik inançlarını değiştirmede etkili olmadığını göstermektedir. Ancak her üç grubun ön ve son test puan ortalamalarına bakıldığında Deney-1 ve Deney-2 gruplarının puan ortalamalarının düştüğü, ancak Kontrol grubunun puan ortalamasının ise değişmediği belirlenmiştir. Bu durum Deney-1 ve Deney-2 gruplarının bilimsel epistemolojik inançlarının geleneksel olmayan bilim anlayışına doğru yöneldiğini göstermektedir.

Deney ve Kontrol grubundaki öğretmen adaylarının epistemolojik inanç ölçeğinden aldıkları ön-test puanları arasında istatistiksel olarak anlamlı bir farklılığın olup olmadığını belirlemek için ($\alpha = .05$) tek yönlü varyans analizi ANOVA sonuçları Tablo 2’de sunulmuştur.

Tablo 2. Epistemolojik inanç ölçeğinden alınan ön-test puanları için yapılan ANOVA testi sonuçları.

	Varyans Kaynağı	Kareler Toplamı	df	Kareler Ortalaması	F	p
Deney-1	Gruplar arası	5,622	2	2,811	32,454	,000**
Deney-2		8,314	96	,087		
Kontrol	Grup içi					

**P<0.01

Tablo 2’den her üç grubun bilimsel epistemolojik inanç ortalamaları arasında istatistiksel olarak bir farklılığın olduğu görülmektedir. Bu durum grupların çalışmaya benzer inanç seviyelerinde başlamadığını göstermektedir. Bu farklılığın hangi gruplar arasında olduğunu belirlemek için Tukey testi yapılmıştır. Ön-test puanlarına yönelik Tukey testi sonuçları Tablo 3’de sunulmuştur.

Tablo 3. Tukey testi sonuçları

	Grup değişkeni	Ortalamalar farkı	p
Deney-1	Deney-2	-,446*	,000
	Kontrol	-,533*	,000
Deney-2	Deney-1	,446*	,000
	Kontrol	-,086	,477
Kontrol	Deney-1	,533*	,000
	Deney-2	,086	,477

*p<0.01

Tablo 3’den Deney-1 ve Deney-2 grupları arasında Deney-2 lehine, Deney-1 ve Kontrol grupları arasında Kontrol grubu lehine istatistiksel olarak anlamlı bir farklılık olduğu görülmektedir. Buna karşın Deney-2 ile Kontrol grubunun inanç puan ortalamaları arasında ise istatistiksel olarak anlamlı bir farklılık bulunamamıştır.

Bu durum Deney-1 grubundaki öğrencilerin inançlarının Deney-2 ile Kontrol grubundaki öğrencilerin inançlarından geleneksel olmayan bilim anlayışına daha yakın olduğunu göstermektedir. Buna karşın Deney-2 ile Kontrol grubunun benzer inançlara sahip olduğu söylenebilir.

Her bir grup için epistemolojik inanç ölçeğinden aldıkları ön-test ve son-test puanları arasında istatistiksel olarak anlamlı bir farklılığın olup olmadığını belirlemek için ($\alpha = .05$) yapılan paired sample t-testi sonuçları Tablo 4’de sunulmuştur.

Tablo 4.

Gruplar	Deney-1			Deney-2			Kontrol		
	df	t	p	Df	t	p	df	t	p
	35	1,356	,184	30	1,474	,151	31	-,120	,905

Tablo 4’den her bir gruptaki öğretmen adaylarının bilimsel epistemolojik inanç ölçeğinden aldıkları ön test ve son test puan ortalamaları arasında istatistiksel olarak anlamlı bir farklılığın olmadığı görülmektedir. Bu durum hem bilimsel araştırma yöntemleri dersi ile hem de farklı bilimsel çalışmalarını incelemenin ya da sadece bilimsel araştırma dersinin öğretmen adaylarının bilimsel epistemolojik inançlarının değişimi üzerinde bir etkisinin olmadığını göstermektedir.

Grupların ön-test puanları kontrol altına alınarak epistemolojik inanç ölçeğinden alınan son-test puanları arasında istatistiksel olarak anlamlı bir farklılığın olup olmadığını belirlemek için ($\alpha = .05$) yapılan kovaryans analizi sonuçları Tablo 5’de sunulmuştur.

Tablo 5. Bilimsel epistemolojik inanç ölçeğinden elde edilen puanlar için kovaryans analizi sonuçları

Ölçümler	F	df	p	LSD ikili karşılaştırma testi		
				Ortalama fark	p	Yön
Toplam	13,461	2	,000			
Deney-1-Deney-2				-,244	,001	Deney-2>Deney-1
Deney-1-Kontrol				-,390	,000	Kontrol>Deney-1
Deney-2- Kontrol				-,146	,022	Kontrol>Deney-2

Tablo 5’den Deney-1, Deney-2 ve Kontrol grubu öğrencilerinin bilimsel epistemolojik inanç ölçeğinin son-test sonuçları arasında istatistiksel olarak anlamlı bir farklılığın olduğunu göstermektedir. LSD ikili karşılaştırma testi sonuçları bu farklılığın Deney-1 ile Deney-2 arasında Deney-2 lehine, Deney-1 ile Kontrol arasında Kontrol lehine ve Deney-2 ile Kontrol arasında yine Kontrol lehine olduğu görülmektedir. Bu durum hem bilimsel araştırma dersini hem de farklı bilimsel çalışmalarını inceleyen Deney-1 grubunun bilimsel epistemolojik inançlarının geleneksel olmayan bilim anlayışına diğer iki gruptan daha fazla yaklaştığını göstermektedir. Bunun yanında sadece bilimsel araştırma yöntemleri dersini alan Deney 2 grubunun ise bilimsel epistemolojik inançları ise Kontrol grubuna göre geleneksel olmayan bilim anlayışına daha fazla yaklaşmaktadır. Bu durum her iki deney grubunda yapılan etkinin bilimsel epistemolojik inançlarının geleneksel olmayan bilim anlayışına doğru olmasına yardımcı olduğunu göstermektedir.

TARTIŞMA VE SONUÇ

Her üç gruptaki öğretmen adaylarının ön-test ve son-test puan ortalamalarına göre bilimsel epistemolojik inançlarının “kararsızım” seviyesinde olduğu görülmektedir. Bu durum bilimsel araştırma yöntemleri dersi ile farklı bilimsel araştırmaları incelemenin öğretmen adaylarının bilimsel epistemolojik inançlarını değiştirmede etkili olmadığını göstermektedir. Ancak her üç grubun ön ve son test puan ortalamalarına bakıldığında Deney-1 ve Deney-2 gruplarının puan ortalamalarının düştüğü, ancak Kontrol grubunun puan ortalamasının ise değişmediği belirlenmiştir. Bu durum Deney-1 ve Deney-2 gruplarının bilimsel epistemolojik inançlarının geleneksel olmayan bilim anlayışına doğru yöneldiğini göstermektedir.

Her bir gruptaki öğretmen adaylarının bilimsel epistemolojik inanç ölçeğinden aldıkları ön test ve son test puan ortalamaları arasında istatistiksel olarak anlamlı bir farklılığın olmadığı görülmektedir. Bu durum hem bilimsel araştırma yöntemleri dersi ile hem de farklı bilimsel çalışmalarını incelemenin ya da sadece bilimsel araştırma dersinin öğretmen adaylarının bilimsel epistemolojik inançlarının değişimi üzerinde bir etkisinin olmadığını göstermektedir.

Her üç grubun son test puan ortalamaları karşılaştırıldığında ise Deney-1, Deney-2 ve Kontrol grubu öğrencilerinin bilimsel epistemolojik inanç ölçeğinin son-test sonuçları arasında istatistiksel olarak anlamlı bir farklılığın olduğu bulunmuştur. Farklılığın Deney-1 ile Deney-2 arasında Deney-2 lehine, Deney-1 ile Kontrol arasında Kontrol lehine ve Deney-2 ile Kontrol arasında yine Kontrol lehine olduğu tespit edilmiştir. Bu durum hem bilimsel araştırma dersini hem de farklı bilimsel çalışmaları inceleyen Deney-1 grubunun bilimsel epistemolojik inançlarının geleneksel olmayan bilim anlayışına diğer iki gruptan daha fazla yaklaştığını göstermektedir. Bunun yanında sadece bilimsel araştırma yöntemleri dersini alan Deney-2 grubunun ise bilimsel epistemolojik inançları ise Kontrol grubuna göre geleneksel olmayan bilim anlayışına daha fazla yaklaşmaktadır. Bu durum her iki deney grubunda yapılan etkinin bilimsel epistemolojik inançlarının geleneksel olmayan bilim anlayışına doğru olmasına yardımcı olduğunu göstermektedir.

KAYNAKLAR

- Brownlee, J. Tickle, E. L. & Nailon, D.,(2004). Epistemological beliefs and transformational-transactional leadership behaviours of directors in child care centres. *Educating: Weaving Research into Practice*. 1,153-166.
- Büyüköztürk, Ş., Kılıç Çakmak, E., Akgün, Ö. E., Karadeniz, Ş. & Demirel, F. (2013). *Bilimsel Araştırma yöntemleri*. Ankara: Pegem Akademi.
- Creswell, J. W. (2012). *Educational research: Planning, conducting, and evaluating quantitative and qualitative research, 4th ed.* Boston: Pearson.
- Deryakulu, D., Bıkmaz, H. F. (2003). Bilimsel Epistemolojik İnançlar Ölçeğinin Geçerlik ve Güvenirlik Çalışması. *Eğitim Bilimleri ve Uygulama*, 2(4), 243–257.
- Hofer, B. K., & Pintrich, P. R. (1997). The development of epistemological theories: Beliefs about knowledge and knowing and their relation to learning. *Review of Educational Research*, 67 (1), 88 -140.
- Pomeroy, D. (1993). Implications of teachers' beliefs about the nature of science: Comparison of the beliefs of scientists, secondary science teachers, and elementary teachers. *Science Education*, 77, (3), 261-278.
- Richardson, V., Anders, P., Tidwell, D. & Lloyd, C. (1991) The relationship between teachers' beliefs and practices in reading comprehension instruction. *American Educational Research Journal*, 28(3), pp. 559–586.

YAŞAM TEMELLİ ÖĞRENME YAKLAŞMIYLA 8. SINIF “SIVILARIN VE GAZLARIN KALDIRMA KUVVETİ” KONUSUNUN ÖĞRETİMİ

TEACHING 8th GRADE “BUOYANCY OF LIQUIDS AND GASES” TOPIC WITH CONTEXT BASED LEARNING

Feray KAHRAMAN
MEB Akpınar OrtaOkulu
feraykahramanktu@gmail.com

Yard. Doç. Dr. Faik Özgür KARATAŞ
Karadeniz Teknik Üniversitesi
fozgurkaratas@gmail.com

ÖZET: Eğitim öğretim sürecinde en önemli hususlardan biri öğrencilerin öğrenmeye istekli olmasıdır. Öğrencilerin öğrenmeye güdülenmelerini sağlamak, derse olan ilgilerini arttırmak ve güdülemek için öğrenme sürecinde yer alan kavramların günlük hayatla ilişkilendirilmesi etkili bir yoldur. Bu araştırmanın amacı, yaşam temelli öğrenme yaklaşımına uygun olarak ilköğretim 8. sınıf öğretim programında yer alan “Sıvıların ve Gazların Kaldırma Kuvveti” konusunun öğretiminin öğrencilerin anlama düzeylerine etkisini incelemektir. Çalışma Trabzon ilinde bir kırsal ortaokulunun 8. sınıf öğrencileri (N= 19) ile yürütülmüştür. Çalışma 6 ders saati boyunca bir eylem araştırması olarak yürütülmüştür. Veri toplama aracı olarak yarı yapılandırılmış mülakatlar ve araştırmacı günlüklerinden yararlanılmıştır. Araştırmacı günlüklerinden elde edilen veriler tümevarımsal bir yaklaşımla, yarı yapılandırılmış mülakatlardan elde edilen veriler ise tümdengelimsel bir yaklaşımla analiz edilmiştir. Verilerin analizinden elde edilen bulgularda, öğrencilerin anlama düzeylerinin genellikle % 50'nin üzerinde olduğu görülmüştür.

Anahtar sözcükler: yaşam temelli öğrenme, hikâyeler, sıvıların ve gazların kaldırma kuvveti

ABSTRACT: One of the most important points in education is the willingness and engagement of students into teaching and learning activities. In order to motivate students and increase their interest to these kinds of activities, an effective method is to connect science concepts with daily life or students' everyday contexts. The aim of this research is to determine the effects of context based learning approach on students' understanding levels of “Buoyancy of Liquids and Gases” topic. The study was conducted as a form of action research with 8th grade students (N: 19) in a rural secondary school in Trabzon and lasted 6 hours. The data were collected from the researcher's journals and semi-structured interviews. The students' responses to the interviews were analyzed by utilizing pre-defined categories. The data from the journals are subjected to content analysis. The findings of the content analysis demonstrated that the students' understanding level is above 50 percent.

Key words: context based approach, stories, buoyancy of liquids and gases

GİRİŞ

Eğitim insanoğlunun varoluşu ile başlayan ve hayat boyu süren bir süreçtir. Bu sürecin en önemli amacı ise yaşam kalitesini arttırmaktır (Başkurt, 2009). Eğitim içerisinde fen bilimleri eğitimi toplumların gelişmesi ve ilerlemesinde oldukça önemli bir yere sahiptir (Çepni & Çil, 2009). Günümüzde temel fen eğitiminin amacı bilimsel düşünebilen, araştıran, sorgulayan, sahip olduğu bilgileri kullanarak karşılaştığı sorunları çözebilen bireyler yetiştirmektir (MEB, 2013; Yücel, 2009). Bu amaca ulaşabilmek için öğrencileri öğrenmeye istekli hale getirmek ve öğrenmeyi öğretmek temel adım olarak görülmektedir.

Fen eğitiminin amaçlarına ulaşmada temel adımlardan bir diğeri ise kavram öğrenimi ve öğretimidir. Varlıklar, olaylar, düşünceler benzerlikleri veya farklılıklarına göre sınıflandırılarak oluşturulan kavramlar soyut birimlerdir (Yağbasan & Gülçiçek, 2003; Yelgün, 2009). Öğrenme sürecinde öğrenciler kavramları anlamlandırmaya çalışırlar. Yağbasan & Gülçiçek, (2003) kavramları bilginin yapıtaşları olarak nitelendirmektedir. Fen Bilimleri dersi iş, enerji, kuvvet ve hareket gibi pek çok soyut kavram içerdiğinden öğrenciler tarafından zor olarak nitelendirilen bir derstir (Aydoğmuş, Sarıkoç & Berber, 2010; Öztürk, 2007). Kavramların günlük hayattan uzak, olgu ve olaylara dayalı olarak öğretimi öğrencilerin derse olan ilgilerini azaltmaktadır (Yılmaz, 2013). Öğrencilerin Fen Bilimleri dersine yönelik ilgilerini arttırmak, olumlu tutum

geliştirmelerini ve öğrenmeye güdülenmelerini sağlamak amacıyla, ders kapsamında yer alan soyut kavramları günlük hayatla ilişkilendirmek etkili bir yoldur (Demircioğlu, Demircioğlu & Ayas, 2006).

Yaşam temelli öğrenme yaklaşımının temel amacı öğrencilere bilimsel kavramları günlük yaşamdan seçilmiş olaylar ile sunmak ve böylece öğrencilerin motivasyonunu artırmak ve bu kavramları anlamlı bir şekilde yapılandırmalarını sağlamaktır (Barker & Millar, 2000). Bağlam öğrencilerin zihninde uygulama ve kavramların ilişkili konumlandırılmasıyla oluşur. Beyin ve öğrenme ile ilgili yapılan çalışmalar öğrenme ortamlarının bağlamdan kopuk olduğunu, buna karşın çok sayıdaki öğrencinin bilgiyi bağlam kurarak somutlaştırıldığında ancak öğrenebildiğini vurgulamaktadırlar. Yaşam temelli öğretme öğrencilerin fen bilimlerine karşı ilgilerini artırmak, gerçek yaşam konuları ile fen bilimleri arasındaki ilişkinin farkına varmalarını sağlamak ve bilimsel süreç becerilerini geliştirmek amaçlarını kapsamaktadır (Demircioğlu, 2008; Yılmaz, 2013). Yaşam temelli öğretimin sınıf içerisinde uygulanmasında, bir öğretim tekniği olarak hikâyelere yer verilebilmektedir. Demircioğlu, Demircioğlu & Ayas, (2006) hikâyelerle öğretimin amacını, “günlük yaşamla ilişki kurmak, fen bilimlerinin içerisinde sosyal ve teknolojik yapıyı iyice yerleştirmek, günlük durumlarda bilimsel kavramların sunumu ile öğrencilerin fen bilimlerine yönelik tutum ve hayranlıklarının gelişmesine yardımcı olmak ve bilimsel okur-yazarlar yetiştirmek.” olarak ifade etmektedir. Bu nedenle yaşam temelli öğrenme yaklaşımı ve hikâyelerin fen öğretiminde kullanım amaçlarının örtüştüğü anlaşılmaktadır.

Kavramlar arasında ilişkilendirmenin yapılabilmesi ve anlamlı öğrenme sağlanabilmesi için hikâyeler de etkili öğretim araçlarından biridir (Klassen, 2009). Hikâyeler gerçek veya gerçeğe uygun olay ve durumlardan esinlenerek yazılmaktadırlar. Bu nedenle öğrencilerin fen bilimlerinde yer alan soyut kavramları günlük hayatla ilişkilendirmelerini kolaylaştırıp anlamlı öğrenme sağlamak için kullanılabilir etkili araçlardır (Bertiz, 2005; Dincel, 2005). Ayrıca Hill & Baumgartner, (2009) hikâyeler ile öğrencilerin öğretim sürecindeki kavramları önce sorgulamaya başladıklarını ardından ise uygun şemalarda yapılandırdıklarını ifade etmektedir. Dolayısıyla hikâyelerin öğrencilerin anlamlı öğrenmesine yardımcı olacağı düşünülmüştür. Bu nedenlerle bu çalışmada 8. sınıf “Sıvıların ve Gazların Kaldırma Kuvveti” konusuna yönelik hazırlanan öğretim materyalinde hikâyelere de yer verilmiştir. Hikâyelerin kültürümüzün de bir parçası olarak öğrencilerin ilgi ve motivasyonunu arttıracığı düşünülmüştür. Yücel, (2009) hikâyelerin öğretim sürecindeki en önemli etkilerinden birinin ise öğrencilerin derse olan ilgi ve motivasyonlarını arttırmaları olduğunu vurgulamaktadır. Fenle ilgili bilgileri ve olayları öğrenmeyi daha zevkli ve istenilir hale getirmek, öğrencilerin günlük hayatta karşılaştıkları olaylara yorum getirebilmelerini sağlamak ve çözüm bulma heyecanlarına katkıda bulunmak için fen derslerinde yaşam temelli öğretime dayalı hikâyeler kullanılmaktadır.

Bu bağlamda çalışmanın amacı yaşam temelli öğrenme yaklaşımına uygun olarak ilköğretim 8. sınıf öğretim programında yer alan “Sıvıların ve Gazların Kaldırma Kuvveti” konusunun öğretiminin öğrencilerin anlama düzeylerine etkisini incelemektir.

YÖNTEM

Çalışmanın belirtilen amacına ulaşmak için takip edilen yol ve yöntemler aşağıdaki detaylı olarak tasvir edilmiş ve gerekli açıklamalarda bulunulmuştur.

Araştırmanın Yöntemi

Bu araştırma 8. sınıf öğrencilerinin “Sıvıların ve Gazların Kaldırma Kuvveti” konularını anlama düzeylerini tespit etmek amacıyla eylem araştırması yöntemi esas alınarak yürütülmüştür. Kurnaz, (2010, s.182) aksiyon araştırmalarını “Eğitim öğretimle ilgili sorunları ve yenilikleri öğretmenin kendi sınıfında araştırarak çözüm ürettiği sürece, aksiyon araştırması denir.” şeklinde tanımlamaktadır. Collins & Spiegel’den (2001) aktaran Yıldırım & Şimşek (2006) ise aksiyon araştırması yöntemini dört aşamada incelemiştir.

1. Problemin Tanımlanması: Araştırmacı öğretmen beş yıllık deneyimi süresince 8. sınıf öğrencilerinin “Sıvıların ve Gazların Kaldırma Kuvveti” konusunu anlamlandırmakta güçlük çektiklerini görmüştür. Bu sorunu çözmeye yönelik bir çalışma yapmaya karar vermiştir.

2. Plan Yapma: Farklı bir öğretim yönteminin öğrencilerin öğrenmelerini olumlu etkileyebileceği düşünülmüştür. Araştırmacı öğretmen öğrencilerinin yaşları ve yaşadıkları çevreyi göz önünde bulundurarak hikâyelerin ve fen kavramlarının günlük hayatla ilişkilendirilmesinin öğrencilerinin ilgisini çekebileceğini ve öğrenmelerini kolaylaştırabileceğini düşünmüştür. Yaşam temelli öğrenme yaklaşımını temel alan materyal hazırlayarak, içerisinde hikâyeye yer vermiştir. “Sıvıların ve Gazların Kaldırma Kuvveti” konusuna dair ders

planı hazırlanmıştır. Veri toplama aracı olarak araştırmacı günlükleri ve yarı yapılandırılmış mülakatlardan yararlanılmasına karar verilmiştir.

3. Planları Uygulama: Çalışma 6 ders saati süresinde fen ve teknoloji derslerinde “Sıvıların ve Gazların Kaldırma Kuvveti” konusunda yürütülmüştür. Uygulama sürecinde gerekli görülen değişiklikler yapılmıştır. Araştırmacı öğretmen, günlüklerini her dersin ardından yazılmıştır. Yarı yapılandırılmış mülakatlar ise uygulama süreci sonunda gerçekleştirilmiştir.

4. Uygulama Sürecinin Değerlendirilmesi: Süreç boyunca araştırmacı günlüklerinden elde edilen veriler doğrultusunda bazı değişiklikler ve konu tekrarlarına yer verilmiştir. Uygulama süreci sonunda elde edilen veriler analiz edilmiş ve değerlendirilmiştir. Bu değerlendirmeler göz önünde bulundurularak bir sonraki yıl gerçekleştirilecek olan “Sıvıların ve Gazların Kaldırma Kuvveti” konusunun öğretim planı şekillendirilecektir.

Bu araştırmanın örneklemini, 2012 – 2013 eğitim öğretim yılında Doğu Karadeniz Bölgesi’nde yer alan bir kırsal ortaokulda 8. sınıfa kayıtlı olan tüm öğrenciler (N: 19) oluşturmaktadır. Sınıfta 11 erkek, 8 kız öğrenci bulunmaktadır. Araştırma sonuçları genelleme amacı taşımamakta bunun yerine araştırmacı öğretmenin kendi sınıfında tespit ettiği problemi çözmeye vurgu yapmaktadır (Yıldırım & Şimşek, 2006).

Araştırma Süreci

Araştırma 6 ders saati süresince eylem araştırması olarak yürütülmüştür. Problemin daha açık ve net olarak tanımlanmasının ardından 8. sınıf fen ve teknoloji öğretim programının “Sıvıların ve Gazların Kaldırma Kuvveti” konusu kazanımlarına uygun, yaşam temelli öğrenme yaklaşımını temel alan yazılı materyal hazırlanmıştır. Bu materyal 2 öğretim üyesi tarafından incelenmiş ve gerekli görülen değişiklikler gerçekleştirilmiştir. Oluşturulan materyalde yer alan hikâye ve etkinliklerinin içerikler konu ve kavramlar Tablo 1’de görülmektedir.

Tablo 1: Araştırma Materyalinin İçerdiği Konu Ve Kavramlar

Bölüm	Konu içeriği
Hikâye (Yaz Tatili)	<ul style="list-style-type: none">▪ Cisimlerin sıvı içersinde yüzmeye, batma veya askıda kalma durumları,▪ Sıvı ve gazlarda kaldırma kuvveti ile yoğunluk ilişkisi,▪ Sıvı ve gazlarda kaldırma kuvveti hacim ilişkisi
Etkinlik 1	<ul style="list-style-type: none">▪ Sıvıların kaldırma kuvveti▪ Sıvıların kaldırma kuvvetinin ile batan hacim ile ilişkisi
Etkinlik 2	<ul style="list-style-type: none">▪ Cisimlerin sıvı içinde yüzmesi, batması veya askıda kalması ile yoğunluk ilişkisi▪ Gemilerin nasıl yüzer,
Etkinlik 3 (Animasyon)	<ul style="list-style-type: none">▪ Gazların kaldırma kuvveti ve günlük hayattan örnek durumlar▪ Gazların kaldırma kuvveti ile hacim ilişkisi▪ Gazların kaldırma kuvveti ve yoğunluk ilişkisi▪ Gezi balonlarının çalışması

Öğrenciler ön bilgileri ve günlük hayat tecrübeleriyle bağlam kurarak öğrenirler. Öğrencilerin yeni fen kavramları ile bağlam oluşturabilmeleri için hazırlanan materyal konu içerisinde yer alan temel kavramların günlük hayatla ilişkilendirmeye yönelik bir hikâye ile başlamaktadır. Hikâyede bir çocuğun ailesi ile çıktığı tatilde yaşadıkları, gözlemleri, düşünceleri ve aklında oluşan bazı sorular yer almaktadır. Hikâye cisimlerin sıvı içersinde yüzmeye, batma veya askıda kalma durumlarına, sıvı ve gazlarda kaldırma kuvveti ile yoğunluk ve hacim ilişkisine yönelik bağlamlar içermektedir. Hikâyenin ardından, öğrencilerin gruplara ayrılarak işbirliği ile etkinlikler yapmaları sağlanmıştır. Etkinliğin gerçekleştirilmesiyle ulaşılan sonuçları yorumlamaları ve hikâyedeki durumlarla ilişkilendirebilmeleri beklenilmiştir. Oluşturulan yazılı materyal, konu içinde yer alan fen kavramlarına yönelik günlük hayattan örnekler içermektedir. Öğrencilerin öğrendikleri bilgileri farklı durumlar üzerinde uygulamaları, bilgilerini transfer edebilmeleri amaçlanmıştır. Farklı örnek durumların açıklanması veya problem çözme etkinlikleri sürecinde, 4 kişiden oluşan öğrenci gruplarının fikir paylaşımlarında bulunmaları için tartışma ortamı oluşturulmuştur.

Verilerin Toplanması ve Analizi

Araştırma nitel bir araştırma deseni olan eylem araştırması yöntemiyle yürütüldüğünden, çalışmada araştırmacı günlükleri ve öğrenci mülakatları gibi nitel veri toplama araçlarından yararlanılmıştır. Araştırmacı günlükleri her dersin ardından dijital olarak tutulmuştur. Araştırmacı günlüklerinde araştırmacı öğretmenin gözlemlerine ve öğrenciler ile arasında geçen diyaloglara; öğrencilerin konu, etkinlikler ve/veya hikâye ile ilgili düşünce ve yorumlarına yer verilmiştir.

Günlüklerden elde edilen veriler içerik analize tabi tutulmuştur. Öncelikle günlükler araştırmacı tarafından tekrar tekrar okunarak kodlanmıştır. Kodlar oluşturulurken öğrencilerin;

- Araştırmacı öğretmenin sınıfa yönelttiği sorulara cevap verebilmesi,
- Konu, hikâye veya materyale yönelik araştırmacıya merak ettikleri soruları sorması,
- Derse ve etkinliklere katılmaya ve görev almaya istekli olması.
- Öğretim materyalindeki hikâye ve örneklerden ve sınıfta yapılan etkinliklerden çıkarım yapabilmesi
- Derste yer alan kavram ve olayları birbirleri ve günlük hayattan örnekler ile ilişkilendirebilmesi
- Konu ve kavramları anlamlandırmakta güçlük çekip çekmemeleri, eksik ve yanlış öğrenmeleri göz önünde bulundurulmuştur.

Bu süreçte 10 adet kod oluşturulmuş ve bu kodlar olumlu ve olumsuz yönler olmak üzere 2 kategoriye ayrılmış ve her kodun sınıfta gerçekleşme sayısı parantez içinde belirtilmiştir. Olumlu yönler kategorisi “sorulara cevap verme”, “öğretmene soru sorma”, “derse ve etkinliklere katılmaya istekli olma”, “çıkarım yapma” ve “ilişkilendirme” kodlarını içermektedir. Olumsuz yönler kategorisinde ise “sorulara cevap verememe”, “anlama güçlüğü”, “ön bilgi eksikliği”, “yanlış anlama”, “bilginin transfer edilmesinde güçlük” kodları yer almaktadır. Ayrıca araştırmacının sürece yönelik düşünceleri de ayrı bir kategori olarak değerlendirilmiştir. Ayrıca araştırmacı öğretmen, öğretim süreci ile ilgili düşüncelerini bu sürecin aksayan yönlerini ve öğretimin kalitesini arttırmaya yönelik yapılabilecek yansıtıcı düşüncelerini de not almıştır.

Yarı yapılandırılmış mülakat soruları 2 öğretim üyesi tarafından incelenmiş, dönütlere göre gerekli düzeltmeler yapılmıştır. Mülakat yapılan öğrencileri belirlemek için, fen ve teknoloji dersi birinci sınav notlarına bakılmıştır. Sınav notları düşük (0-54), orta (54- 84) ve yüksek başarı (85-100) düzeyinden 1’er kız, 1’er erkek olmak üzere toplam 6 öğrenci belirlenmiştir. Mülakatlarda “Sıvıların ve Gazların Kaldırma Kuvveti” konusu ile ilgili toplam 10 açık uçlu sorulmuştur. İlk üç soruda öğrencilerden kaldırma kuvvetinin tanımlanması ve günlük hayattan örnekleri, kaldırma kuvveti ile yoğunluk ve kaldırma kuvveti ile cismin batan hacmi ilişkisine dair bildiklerini paylaşmaları istenilmiştir. Diğer sorularda ise şekiller üzerinde farklı konum ve durumlarda bulunan cisimler üzerinden kaldırma kuvvetinin hesaplanması, kaldırma kuvveti ile yoğunluk ve kaldırma kuvveti ile cismin batan hacmi ilişkisine yönelik yorum yapmaları beklenilmiştir. Son soruda ise sıvı dolu kapta yüzen bir cisim üzerine etki eden kuvvetleri çizmeleri ve nedenini açıklamaları istenilmiştir. Bazı öğrencilerin soruyu tam anlamadıklarını belirttiklerinde şekil veya örnek üzerinde ifade edebilmeleri için duruma uygun sorular eklenmiştir.

Yarı yapılandırılmış mülakatlardan elde edilen verilerin analizi için Abraham, Grzybowski, Renner & Marek, (1992) ve Coştu’nun (2002) çalışmalarında kullandıkları kategoriler dikkate alınarak Tablo 2’deki kategoriler çalışmaya uygun olarak düzenlenmiştir. Öğrencilerin mülakatlarda yer alan sorulara verdikleri cevaplar “Anlama,” “Kısmen Anlama,” “Anlamama,” “ Yanlış Anlama” ve “Cevapsız” olmak üzere 5 kategoride sınıflandırılmıştır. Mülakat verilerinin analizinde kullanılan anlama düzeylerine ilişkin değerlendirme ölçütleri Tablo 2’de gösterilmiştir.

Tablo 2: Mülakat Sorularını Analiz Etmede Kullanılan Kategoriler Ve Puanlama Ölçütleri

Anlama Düzeyleri	Değerlendirme Kriterleri
Anlama	▪ Geçerliliği olan cevabın bütün yönlerini içeren cevaplardır
Kısmen Anlama	▪ Geçerli olan cevabın bir yönün içeren fakat bütün yönlerini içermeyen cevaplardır ▪ Geçerli cevabın bazı yönleriyle birlikte bazı yanlış açıklamaları içeren cevaplardır
Yanlış Anlama	▪ Kavram yanlışlığı içeren cevaplar
Anlamama	▪ İlgisiz ya da açık olmayan cevap verme ▪ Mantıksız ya da doğru olmayan bilgiler içeren cevaplar

Cevapsız	<ul style="list-style-type: none"> ▪ “Bilimiyorum...”, Fikrim yok...” şeklinde ifadelerin yer aldığı cevaplar ▪ Soruyu aynen tekrarlama
----------	---

Puanlamanın güvenilirliğini ortaya koymak amacıyla iki öğrenci mülakatı MEB’e bağlı bir ortaokulda 6 yıllık deneyime sahip bir Fen ve Teknoloji öğretmeni tarafından da puanlanmış, araştırmacının puanlamasıyla karşılaştırılmıştır. Tutarlılık oranı 0,87 olarak belirlenmiştir.

BULGULAR

Araştırma sürecinde elde edilen bulgulara, araştırmacı günlüklerinden elde edilen bulgular ve yarı yapılandırılmış mülakatlardan elde edilen bulgular olmak üzere iki başlık altında yer verilmiştir.

Araştırmacı Günlüklerinden Elde Edilen Bulgular

Araştırmacı günlüklerinde sınıf gözlemlerine, sınıfta yaşanan olay ve durumlara, bazı diyaloglara ve öğretim sürecine yönelik değerlendirmelere yer vermiştir. Günlüklerden elde edilen veriler incelendiğinde sınıfın yaklaşık yarısının derse aktif olarak katıldığı, soruları cevaplamaya ve etkinliklere katılmaya istekli oldukları görülmüştür. Günlüklerden elde edilen veriler doğrultusunda sınıfın genel durumunu yansıtmak amacıyla Tablo 3 oluşturulmuştur.



Tablo 3: Araştırmacı Günlüklerinden Elde Edilen Bulgular

Konu	Olumlu Yönler	Olumsuz Yönler
Sıvıların kaldırma kuvveti	<ul style="list-style-type: none"> ▪ Sorulara cevap verme (12) ▪ Öğretmene soru sorma (5) ▪ Derse ve etkinliklere katılmaya istekli olma (9) ▪ Çıkarım yapma (4) ▪ İlişkilendirme (3) 	<ul style="list-style-type: none"> ▪ Sorulara cevap verememe (2) ▪ Anlama güçlüğü (4) ▪ Ön bilgi eksikliği (1) ▪ Yanlış anlama (4) ▪ Bilginin transfer edilmesinde güçlük (4)
Gazların kaldırma kuvveti	<ul style="list-style-type: none"> ▪ Sorulara cevap verme (4) ▪ Öğretmene soru sorma (3) ▪ Derse ve etkinliklere katılmaya istekli olma (2) ▪ Çıkarım yapma (2) ▪ İlişkilendirme (3) 	<ul style="list-style-type: none"> ▪ Sorulara cevap verememe (1) ▪ Anlama güçlüğü (1) ▪ Yanlış anlama (2) ▪ Bilginin transfer edilmesinde güçlük (1)

Tablo 3’de görüldüğü gibi, öğrenciler bazen anlama güçlüğü çekmiş, eksik ve yanlış öğrenmeler gerçekleştirmiş veya bilginin transferinde zorlanmışlardır. Bunun yanında olumlu yönde gözlenen gelişim sayısı daha fazladır. Öğrencilerin hikâyede geçen cümlelerin ardından sorular sormaları, yorumlar yapmaları hikâyenin ilgilerini çektiğini göstermektedir. Örneğin “Oysa o dev gemiler nasıl oluyor da su üstünde kalabiliyordu?” cümlesinden sonra “Evet, hocam yaa nasıl oluyor?” sorusu yöneltmişlerdir. “Taş her defasında hemencecik dibe batıyordu. Oysaki boş plastik şişe hep su üstünde yüzüyordu.” cümlesinden sonra hep bir ağızdan “Doğruuu...” tepkisi verildiği görülmüştür. Ayrıca bazı öğrenciler hikâyede geçen yamaç paraşütünün nasıl yapıldığını, Saklıkent’in nerede olduğunu sormuşlardır.

Sıvıların kaldırma kuvvetini kavramaya yönelik yapılan etkinlikte, öğrencilerin kendi grupları içerisinde dinamometreyi tutmak veya ölçümleri okumak için birbirleri ile yarışmaları ilgilerinin yüksek olduğunu göstermektedir. Benzer şekilde “Öğretmenim dinamometrede değer okumayı bize öğretir misiniz?” diye sormalarından yola çıkarak derse ve öğrenmeye istekli oldukları sonucuna ulaşılabilir. Dersler süresince öğrencilerin okudukları hikâyeden veya yapılan etkinliklerden çıkarımlarda bulunabildikleri gözlenmiştir. Örneğin; cismin havadaki ve sudaki ağırlıklarını dinamometre ile ölçerek yapılan etkinlikte, öğrencilerden taşın suya battıkça sıvı yüksekliğindeki değişimi gözlemlenmeleri istenmiştir. Burada yaklaşık 8 – 10 öğrencide “Taş battıkça sıvı seviyesi artıyor” ifadesini kullanmıştır. Taş tamamen suya battığında ise sıvı yüksekliğindeki değişimin taşın hacmine eşit olduğu çıkarımını yapabilmişlerdir.

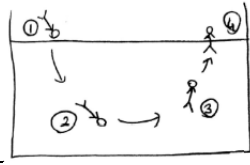
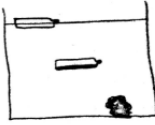
Araştırmacı günlüklerinde yer alan notlar incelendiğinde, öğrencilerin bazı yanlış anlamalara sahip oldukları görülmüştür. Yoğunluk kavramına geldiğinde öğrencilerin kütle, hacim, yoğunluk, ağırlık kavramlarını birbirine karıştırmaları, bu duruma örnek verilebilir. Bazı öğrencilerin gemilerin altındaki boşluğun geminin yoğunluğunu azalttığını değil, ağırlığını azalttığını düşündükleri “...altında boşluk olunca gemi hafif olur,

Nedenini açıklar mısın?					
<p>8.</p>  <p>Şekildeki dalgıcın deniz içerisinde yüzdüğü farklı konumlar şekil üzerinde numaralandırılmıştır. Buna göre 1, 2, 3 ve 4 konumlarında dalgıca etki eden kaldırma kuvvetlerini karşılaştırınız. Cevabınızın nedenini açıklar mısınız?</p>	3	2	1	0	0
<p>9.</p>  <p>Su içerisinde boş şişe, yarısı su dolu şişe ve taş şeklindeki konumlarda dengededir. Buna göre bu cisimlerin yoğunlukları ile sıvının yoğunluğu arasında nasıl bir ilişki vardır? Açıklar mısınız?</p>	4	1	1	0	0
<p>10.</p>  <p>Şekildeki su içerisinde yüzen cisme etki eden kuvvetleri şekil üzerine çizebilir misiniz? Nedenini açıklar mısınız?</p>	4	2	0	0	0

Mülakatlardan elde edilen veriler incelendiğinde genellikle anlama düzeyinin % 50'nin üzerinde olduğu görülmektedir. İlk mülakat sorusu olan "Kaldırma kuvveti denilince aklına ne geliyor? Açıklar mısın?" sorusunda 3 öğrenci "Anlama", 1 öğrenci "Kısmen Anlama", 1 öğrenci "Anlamama", 1 öğrenci ise "Yanlış Anlama" kategorisinde yer almaktadır. "Yanlış Anlama" kategorisinde yer alan Arzu katılarında kaldırma kuvveti uyguladığını belirterek, sıkıştırılan bir yayın bırakıldığında cisme uyguladığı kuvvetin örnek olabileceğini belirtmiştir. Sıvının yoğunluğu ile kaldırma kuvveti ilişkisinin sorulduğu 2. mülakat sorusunda 5 öğrencinin cevapları "Anlama" kategorisinde yer almaktadır. "Anlamama" kategorisinde yer alan Fatma yoğunluğu az olan sıvının daha fazla kaldırma kuvveti uygulayacağını düşünmektedir. Cismin sıvıya batan hacmi ile kaldırma kuvveti ilişkisinin sorulduğu 3. mülakat sorusunda 3 öğrenci "Anlama", 2 öğrenci "Anlamama" kategorisindeyken 1 öğrenci ise soruyu cevapsız bırakmıştır.

En az tam olarak doğru cevaplanan soru olan 4. mülakat sorusu sıvı içerisinde farklı denge konumlarında eşit hacim bölmeli cisimlerin yoğunluklarının kıyaslanmasını kapsamaktadır. Mülakatlardan elde edilen veriler ile Mustafa'nın bu soruda olduğu gibi birçok soruda kavramları açıklayamadığı, ayırt etmekte zorlandığı görülmüştür.

Araştırmacı: *Eşit hacim bölmeli cisimler sıvı içerisinde şekildeki gibi dengededir. Buna göre cisimlerin yoğunluklarını kıyaslar mısın?*

Mustafa: $D > B = E > A = C$

Araştırmacı: *Neden böyle sıraladığını açıklar mısın?*

Mustafa: *En büyük D çünkü batmış. B ve E eşit çünkü askıda kalmış. A ve C de eşit çünkü ikisi de yüzüyo. A ve C, B ve E'den daha yoğun çünkü daha az batmışlar.*

Fatma'nın ise aynı soruda farklı bir yanlış anlamaya sahip olduğu aşağıdaki ifadelerinde görülmektedir.

Fatma: $D > B > E > C > A$

Araştırmacı: *Nedenini açıklar mısın?*

Fatma: *En büyük D en altta batmış. Sonra B, sonra E, sonra C yarısından fazlası battı. En az A çünkü 1 kutu battı.*

Araştırmacı: *Nasıl bir açıklama yaparsın o zaman?*

Fatma: *Yoğunluğu arttıkça daha fazla, daha dibe batıyor.*

Sıvı içerisinde farklı konumlarda dengede olan eşit kütleli cisimlerin kaldırma kuvvetlerini karşılaştırılmasını içeren 5. Mülakat sorusunun cevapların dağılımına bakılacak olursa 2 öğrenci "Anlama", 2 öğrenci "Anlamama", 2 öğrenci "Yanlış Anlama" şeklinde olduğu görülmektedir. "Yanlış Anlama" kategorisinde yer

alan 2 öğrencinin “Yoğunluğu fazla olan cisme daha fazla kaldırma kuvveti uygulanır.” yanılığına sahip olduğu tespit edilmiştir. 6. mülakat sorusunda ise 4 öğrenci “Anlama”, 2 öğrenci “Kısmen Anlama” kategorisinde yer almaktadır. Hava bulunan ve bulunmayan ortamlarda farklı konumlarda duran özdeş balonların yorumlanmasına yönelik 7. mülakat sorusunun cevapları incelendiğinde 4 öğrencinin “Anlama”, 1 öğrencinin “Kısmen Anlama”, 1 öğrencinin ise “Anlamama” kategorisinde olduğu görülmektedir. “Anlamama” kategorisinde yer alan Mustafa “Havasız ortamda yoğunluk daha fazla...” ifadesini kullanmıştır.

Cismin batan hacmi ile kaldırma kuvveti ilişkisine yönelik 8. mülakat sorusunda 3 öğrenci “Anlama”, 2 öğrenci “Kısmen Anlama”, 1 öğrenci ise “Anlamama” kategorisinde yer almaktadır. “Anlama” kategorisinde yer alan Emre’nin açıklamasına aşağıda yer verilmektedir.

Araştırmacı: *Bir dalgıcın yüzdüğü noktalar şekilde görülmektedir. Bu dalgıca 1, 2, 3 ve 4 konularında etki eden kaldırma kuvvetlerini karşılaştırır mısın?*

Emre: *1’de yüziyo mu? Suyu girdi mi?*

Araştırmacı: *Hayır, henüz girmedir. Kaldırma kuvveti var mı?*

Emre: *Var ama havanın, suyun yok.*

Araştırmacı: *1,2,3 ve 4 konularındaki kaldırma kuvvetlerini karşılaştırır mısın?*

Emre: *2 ve 3 eşit. 4 onlardan küçük, 1 en az.*

Araştırmacı: *Nedenini açıklar mısın?*

Emre: *2 ve 3’de batan hacimleri eşit, o yüzden kaldırma kuvvetleri eşit. 4’de batan hacim azalmış, o yüzden kaldırma kuvveti azalıyor. 1’de havanın kaldırma kuvveti suyunkinden az zaten.*

Araştırmacı: *Neden havanın kaldırma kuvveti suyunkinden az?*

Emre: *Çünkü havanın yoğunluğu daha az.*

Sıvı içersinde farklı konumlarda dengede olan cisimlerin yoğunlukları ile sıvının yoğunluğunun karşılaştırılmasını içeren 9. mülakat sorusunda 4 öğrenci “Anlama”, 1 öğrenci “Kısmen Anlama” ve 1 öğrenci “Anlamama” kategorisinde yer almaktadır. Sıvının yoğunluğu ile yarısı su dolu şişenin yoğunluğunun kıyaslanması sırasında Merve “Yarısı su dolu şişe askıda kalmış. Burada kaldırma kuvveti kıyaslamadığımız için, bunun ki suyunkinden biraz daha fazla.” açıklamasında bulunmuştur. 10. mülakat sorusunda ise öğrencilerden su içersinde yüzmekte olan bir tahta parçasının üzerine etki eden kuvvetleri çizmeleri ve çizimlerini açıklamaları beklenilmiştir. Bu soruda 4 öğrencinin “Anlama”, 2 öğrencinin ise “Kısmen Anlama” kategorisinde yer aldığı görülmüştür. Tüm öğrencilerin sıvının kaldırma kuvvetini doğru şekilde çizdiği ve açıkladığı, ancak 2 öğrencinin ağırlığı çizemediği görülmüştür.

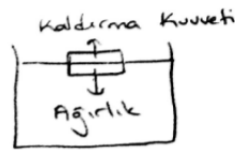

Emre’nin çizimi



Mustafa’nın çizimi

TARTIŞMA

Bu çalışmanın amacı yaşam temelli öğrenme yaklaşımına uygun olarak ilköğretim 8. sınıf öğretim programında yer alan “Sıvıların ve Gazların Kaldırma Kuvveti” konusunun öğretiminin öğrencilerin anlama düzeylerine etkisini incelemektir. 6 ders saati süresince yaşam temelli öğrenme yaklaşımı temel alınarak uygulama gerçekleştirilmiştir. Araştırma materyali kapsamında yer alan hikâye ile ilgili öğrencilerin sorular sormaları, hikâyede yer alan olay ve resimler üzerine yorumlar, şakalar yapmaları, hikâyeyi okumaya istekli olmaları hikâyenin öğrencilerde ilgi ve merak uyandırdığını göstermektedir. Nitekim Dincel, (2005); Frisch, (2010);

Klassen, (2009); Robertson & Blake, (2011), Kahraman (2012) hikâyelerin öğrencilerin derse olan ilgilerini arttırdığı ve onları güdülediği sonucuna ulaşmıştır.

Araştırma sürecinde öğrenciler, cismi sıvıya batırılarak dereceli kaptaki sıvı yüksekliğindeki değişimi incelemiş ve bu değişimin cismin sıvıya batan hacmine eşit olduğu çıkarımında bulunabilmişlerdir. MEB'in gerek 2006'da gerekse 2013'te yayımladığı ortaokul fen öğretim programlarında, öğrencilerin karşılaştırma yapma, gözlemlerini açıklama, yorumlama, gözlem ve deneyimlerinden çıkarım yapma gibi bilimsel süreç becerilerinin kazandırılması amaçlanmaktadır. Araştırmacı öğretmenin sınıf-içi yaptığı gözlemlere dayanarak öğrencilerin yapılan etkinlikler ve hikâyeden çıkarımlarda bulunabildiklerinin tespiti bu amaca ulaşmada önemli bir adım olarak nitelendirilmektedir. Bunun yanı sıra öğrencilerin "Askıda kalan cisimlerin yoğunlukları eşit oluyorsa (batan hacime bakılmaksızın) yüzen cisimlerin de öyle olmalı..." gibi yanlış çıkarımlarda da bulunabildikleri görülmüştür. Öğrencilerin öğrendikleri kavramları benzer durumlara genelleme çalıştıkları düşünülmektedir. Öğretmen kontrolünde gerçekleştirilen etkinlikler dâhil olmak üzere öğrencilerin yanlış yorumlamalar ve çıkarımlarda bulunabilmektedirler. Bir başka yanlış çıkarım olarak bazı öğrencilerin gemilerin altındaki boşluğun geminin yoğunluğunu değil, ağırlığını azalttığı için yüzebildiklerini düşüncesidir. Benzer olarak yapılan çalışmalardan öğrencilerin "Sıvılar hafif cisimlere kaldırma kuvveti uygulayabilir, ağır olan cisimlere uygulayamaz.", "Hafif olana daha çok kaldırma kuvveti etki eder" gibi fikirlere sahip oldukları görülmüştür (Çiğdem, 2010; Yelgün, 2009). Öğrencilerin günlük hayatta hafif cisimleri kaldırmanın daha kolay olduğundan yola çıkarak bu tür yanlış düşüncelere sahip olabilecekleri düşünülmektedir. Benzer şekilde Yelgün (2009) öğrencilerin yanlış yorum ve çıkarımlar yapabiliyor olmasının, önceki yaşantılarından, gözlemlerinden veya aşırı genellemelerinden kaynaklanabileceğini belirtmektedir.

Mülakatlardan elde edilen bulgularda görüldüğü gibi sıvı içerisinde askıda kalan cisimler için öğrenci 1 "*Yoğunluğu arttıkça daha fazla, daha dibe batıyor.*" ifadesini kullanmıştır. Yelgün, (2009) öğrencilerin "*Aynı sıvı içinde farklı derinliklerde asılı duran cisimlerin öz kütleleri farklıdır.*" düşüncesine sahip olduklarına ulaşmıştır. Öğrencilerin yoğunluğu sıvının yoğunluğundan küçük cisimlerin sıvıda yüzerken, yoğunluğu sıvının yoğunluğundan büyük olan cisimlerin batması kavramından yola çıkarak genellemeye gittikleri düşünülmektedir. Bu konuda öğrencilerin en çok askıda kalan cisimlerin yoğunluklarının sıvının yoğunluğuna eşit olduğunu anlamlandırmakta zorlandıkları görülmektedir. Bunun nedeninin günlük hayatta sıvı içerisinde askıda kalan cisim örneği ile pek karşılaşmamaları olduğunu düşünülmektedir. Hırça, Çalık & Seven (2011); Avcı & Yağbasan (2010) fen kavramlarının günlük hayatla ilişkilendirilmesi ile anlamlı öğrenmenin sağlanacağını vurgulamaktadır. Bu nedenle yaşam temelli öğrenme yaklaşımı temel alınan öğretim ortamları daha etkili öğrenme sağlayabilir.

Öğrencilerin kütle, hacim, yoğunluk, ağırlık gibi kavramları karıştırdıkları, bu kavramları birbirinden ayırt etmekte zorlandıkları araştırmacı günlüklerinden elde edilen bulgular arasında yer almaktadır. Günlükteki bulgulara benzer olarak 2 öğrencinin "*Yoğunluğu fazla olan cisme daha fazla kaldırma kuvveti uygulanır.*" yanıtına sahip olduğu mülakatlardan elde edilen veriler arasında yer almaktadır. Benzer şekilde Yelgün, (2009) ve Şahin, (2010) öğrencilerin yoğunluğa fazla olan cisimlere daha fazla kaldırma kuvveti uygulandığını düşündükleri sonucuna ulaşmışlardır. Eksik öğrenmeler nedeniyle veya yeni bilgiler ile ön bilgilerin çeliştiği durumlarda öğrencilerin kavram yanlışlarına sahip olabilecekleri görülmektedir. Fen ve Teknoloji dersinin sarmal yapısı nedeniyle bu durumun öğrencilerin yüzmeye, batma, sıvıların ve gazların kaldırma kuvveti gibi konuların anlamlı öğrenilmesinde güçlük yarattığı düşünülmektedir. Nitekim Özsevgeç ve Çepni (2006) öğrencilerin yoğunluk, kütle ve hacim kavramlarını anlamlı öğrenemediklerini, bu nedenle yoğunluk - kaldırma kuvveti - hacim kavramlarını ilişkilendirmekte zorlandıklarını ifade etmektedir. Bu nedenle öğretimin ilk kademelerinden itibaren bu tür soyut kavramların öğretiminde daha fazla etkinliğe yer verilmesinin uygun olacağı düşünülmektedir.

SONUÇ VE ÖNERİLER

Araştırma süreci sonucunda elde edilen bulgular doğrultusunda uygulama süresince sınıftaki öğrencilerin yaklaşık yarısının sıklıkla dersle, hikâyeyle, etkinliklerle ilgili sorular sordukları, yorumlar ve şakalar yaptıkları, etkinliklerde görev almaya istekli oldukları ifade edilebilir. Bu nedenle geliştirilen yaşam temelli öğretim materyalinin hedeflendiği gibi sınıftaki öğrencilerin ilgilerini genel olarak arttırdığı söylenebilir. Ancak, araştırmadan elde edilen sonuçlar doğrultusunda öğrencilerin derse olan ilgilerini arttırmaya ve derse güdülenmelerini sağlamaya yönelik hikâyelerin drama şeklinde canlandırılması gibi etkinlikler eklenebileceği düşünülmektedir.

Araştırmacı günlüklerinde yer alan notlardan yararlanılarak bazı öğrencilerin kütle, hacim, yoğunluk, ağırlık gibi soyut kavramları anlama güçlüğü çektikleri görülmektedir. Buna paralel olarak da yoğunluk - kaldırma kuvveti - hacim kavramlarını ilişkilendirmekte ve "Sıvıların ve Gazların Kaldırma Kuvveti" konusunu

anlamlandırmakta zorlandıkları düşünülmektedir. Öğrenme güçlüğü yaşanan bu soyut kavramların öğretiminde yaşam temelli öğrenme yaklaşımı ile bilgilerin günlük hayatla ilişkilendirilerek daha kolay öğrenildiği sonucuna varılmıştır. Benzer uygulamaların diğer konular ve kavramlar ile yapılmasıyla benzer faydalar sağlanabilir. Bu uygulamalar veya materyaller geliştirilirken öncelikle öğrencilerin ön bilgilerinin yoklanması ve bu eksikliklerin giderilmesine yönelik alternatif etkinlikler eklenmesi, uygulamanın amaca daha iyi hizmet etmesini sağlayacağına inanılmaktadır.

Öğrencilerin uygulama süresinde yapılan etkinlikler ve hikâye ile ilgili yorum ve açıklamalar yapabildikleri ve çıkarımlarda bulunabildikleri görülmüştür. Bu süreçte öğrencilerin doğru sonuçlara ulaşabildikleri gibi bazı yanlış düşüncelere ve çıkarımlara ulaşabildikleri görülmüştür. Bu durumun öğrencilerin günlük hayattaki gözlemlerinden veya aşırı genelleme özelliklerinden kaynaklanabileceği düşünülmektedir. Öğrencilerin öğrendikleri bilgileri uygulama ve farklı durumlara transfer etmelerine yönelik daha fazla etkinlik ve proje çalışmasına katılmalarının yanlış öğrenmelerini azaltabileceği düşünülmektedir. Bu nedenle bir sonraki uygulama için basit araç gereçlerle yapılan öğretim etkinliklerine daha fazla yer verilmesi düşünülmektedir. Ayrıca basit araç gereçler kullanımı ile öğrencilerin modeller oluşturmalarının öğrenmelerine katkı sağlayacağı düşünülmüştür.

Yarı yapılandırılmış mülakatlardan elde edilen bulgular incelendiğinde 2 soru hariç tüm sorularda “Anlama” kategorisindeki öğrenci sayısının %50 ve üzerinde olduğu görülmektedir. Tablo 4’te yola çıkarak genel olarak öğrencilerin “Sıvıların ve Gazların Kaldırma Kuvveti” konusunu anlama düzeylerinin iyi olduğu ifade edilebilir. Ancak süreç boyunca öğrencilerin öğrenmeleri ve düşünceleri ile ilgili diyalog halinde olunarak, öğrencilerin sahip olabileceği yanlış anlamaların anında dönütler ile düzeltilmeye çalışılmasının anlama düzeylerinin daha da geliştirilmesi için etkili olabileceği düşünülmektedir. Bunun yanı sıra öğrencilerin yanlış anlamalarının giderilmesinde kavram karikatürleri veya kavramsal değişim metinlerinden yararlanılabilir.

KAYNAKLAR

- Avcı, D. E. ve Yağbasan, R. (2010). Beyin Temelli Öğrenme Hakkında Öğrenci Görüşleri, Kastamonu Eğitim Fakültesi Dergisi, Ocak 2010, 18, 1, 1-18.
- Aydoğmuş, E., Sarıkoç, A. ve Berber N.C. (2010). Lise 2 Fizik Dersi İş – Enerji Konusunun Öğretiminde 5E Modelinin Öğrenci Başarısına ve Tutuma Etkisinin Araştırılması, Selçuk Üniversitesi Ahmet Keleşoğlu Eğitim Fakültesi Dergisi, 29, 83 -94.
- Başkurt, P. (2009). İlköğretim 8. Sınıf Fen ve Teknoloji Dersi Kuvvet ve Hareket Ünitesinin Basit Malzemelerle Yapılan Fen Aktiviteleri ile Öğretilmesinin Başarıya, Kalıcılığa ve Tutuma Etkisi, Yayınlanmamış Yüksek Lisans Tezi, Gazi Üniversitesi, Eğitim Bilimleri Enstitüsü, Ankara.
- Barker, V. ve Millar, R., (2000). Students’ Reasoning about Basic Chemical Thermodynamics and Chemical Bonding: What Changes Occur During A Context-Based Post-16 Chemistry Course?, International Journal of Science Education, 22, 11, 1171- 1200.
- Bertiz, H. (2005). Fen Bilgisi Öğretmen Adaylarının Yaratıcı Dramaya Yönelik Tutumları ve Öyküleme Çalışmalarına İlişkin Görüşleri, Yayınlanmamış Yüksek Lisans Tezi, Abant İzzet Baysal Üniversitesi, Sosyal Bilimler Enstitüsü, Bolu.
- Coştu, B. (2002). Ortaöğretimin Farklı Seviyelerindeki Öğrencilerin Buharlaştırma Yoğunlaştırma ve Kaynama Kavramlarını Anlama Düzeylerine İlişkin Bir Çalışma, Yayınlanmamış Yüksek Lisans Tezi, Karadeniz Teknik Üniversitesi, Fen Bilimleri Enstitüsü, Trabzon
- Çepni, S. ve Çil, E. (2009). Fen ve teknoloji programı ilköğretim 1. ve 2. Kademe öğretmen kitabı. Pegem A yayıncılık, Ankara.
- Demircioğlu, H., (2008). Sınıf Öğretmeni Adaylarına Yönelik Maddenin Halleri Konusuyla İlgili Bağlam Temelli Materyal Geliştirilmesi ve Etkililiğinin Araştırılması, Yayınlanmamış Doktora Tezi, Karadeniz Teknik Üniversitesi, Eğitim Bilimleri Enstitüsü, Trabzon.
- Demircioğlu, H., Demircioğlu, G. ve Ayas, A., 2006. Hikâyeler ve Kimya Öğretimi, Hacettepe Üniversitesi Eğitim Fakültesi Dergisi, 30, 110-119.
- Dinçel, M. (2005). Öyküleme ve Deney Tekniğinin Fen Bilgisi Dersinde Öğrencilerin Kavramsal Anlama ve Başarılarına Etkisi, Yayınlanmamış Yüksek Lisans Tezi, Marmara Üniversitesi, Eğitim Bilimleri Enstitüsü, İstanbul.
- Frisch, J. K. (2010). The Stories They’d Tell: Pre-Service Elementary Teachers Writing Stories to Demonstrate Physical Science Concepts, Journal Science Teacher Education, 21, 703–722.

- Hırça, N., Çalık, M. ve Seven, S. (2011). 5E Modeline Göre Geliştirilen Materyallerin Öğrencilerin Kavramsal Değişimine ve Fizik Dersine Karşı Tutumlarına Etkisi: “İş, Güç ve Enerji” Ünitesi Örneği, *Türk Fen Eğitimi Dergisi*, Mart 2011, 1, 139 – 152.
- Hill, C. and Baumgartner, L. (2009). Stories in Science: The Backbone of Science Learning, *The Science Teacher*, April/May 2009, 60-66.
- Kahraman, F., (2012). Bilim Tarihi Temelli Hikâyelerin İlköğretim 7. Sınıf Öğrencilerinin “Kuvvet ve Hareket” Ünitesi Kavramlarını Anlama Düzeylerine Etkisi, *Yayınlanmamış Yüksek Lisans Tezi*, Karadeniz Teknik Üniversitesi, Eğitim Bilimleri Enstitüsü, Trabzon.
- Klassen, S. (2009). The Construction and Analysis of a Science Story: A Proposed Methodology, *Science & Education*, 18, 3 – 4, 401 – 423.
- Kurnaz, M. A. (2010). Kavram Haritalarının Öğretim Sürecinde Kullanılması: Bir Aksiyon Araştırması, *Türk Eğitim Bilimleri Dergisi*, Kış 2010, 8(1), 175-199.
- Milli Eğitim Bakanlığı. (2006). İlköğretim Fen ve Teknoloji Programı (6-8. sınıf). Milli Eğitim Bakanlığı Yayınları, Ankara, 2006.
- Milli Eğitim Bakanlığı. (2013). İlköğretim Fen ve Teknoloji Programı (6-8. sınıf). Milli Eğitim Bakanlığı Yayınları, Ankara, 2013.
- Özsevgeç, T. ve Çepni S. (2006). Farklı Sınıflardaki Öğrencilerin Yüzme ve Batma Kavramlarını Anlama Düzeyleri, *Millî Eğitim Dergisi*, 172, 297-311
- Öztürk, G. (2007). Öğrencilerin Basit Malzemelerle Yaptıkları Deneylerin Kuvvet-Enerji Kavramını Öğrenmelerine ve Fene Karşı Tutumlarına Etkisi, *Yayınlanmamış Yüksek Lisans Tezi*, Marmara Üniversitesi, Eğitim Bilimleri Enstitüsü, İstanbul.
- Robertson, A. ve Blake, K. (2011). Students Gain a Sense of Place by Learning About Their Local Ecosystem, *Science and Children*, November 2011, 48-54.
- Şahin, Ç. (2010). İlköğretim 8. Sınıf “Kuvvet ve Hareket” Ünitesinde “Zenginleştirilmiş 5E Öğretim Modeli”ne Göre Rehber Materyaller Tasarlanması, Uygulanması ve Değerlendirilmesi, *Yayınlanmamış Doktora Tezi*, Karadeniz Teknik Üniversitesi, Fen Bilimleri Enstitüsü, Trabzon.
- Yağbasan, R. ve Gülçiçek, Ç. 2003. Fen Öğretiminde Kavram Yanılgılarının Karakteristiklerinin Tanımlanması. *Pamukkale Üniversitesi Eğitim Fakültesi Dergisi*, 1 (13), 102-120.
- Yelgün, A. (2009). İlköğretim 8. Sınıf Öğrencilerinin Sıvıların Kaldırma Kuvveti ile İlgili Kavram Yanılgıları ve Oluşum Sebepleri, *Yayınlanmamış Yüksek Lisans Tezi*, Atatürk Üniversitesi Fen Bilimleri Enstitüsü, Erzurum.
- Yıldırım, A. ve Şimşek, H. (2006), *Sosyal Bilimlerde Nitel Araştırma Yöntemleri* (6. Basım), Ankara, ANK: Seçkin Yayıncılık.
- Yılmaz, S.S., (2013). Kimyasal Değişimler Ünitesinin İşlenmesinde Yaşam Temelli Öğrenme Yaklaşımının Etkileri *Yayınlanmamış Doktora Tezi*, Atatürk Üniversitesi, Eğitim Bilimleri Enstitüsü, Erzurum.
- Yücel, M. (2009). Etkileşimli Kısa Tarihsel Hikâyelerin Kullanımının İlköğretim İkinci Kademe Öğrencilerinin Bilimin Doğasına Yönelik Anlayışlarını Geliştirmesindeki Etkililiği, *Yayınlanmamış Yüksek Lisans Tezi*, Gazi Üniversitesi, Eğitim Bilimleri Enstitüsü, Ankara.

İLKOKUL ÖĞRENCİLERİNE YÖNELİK TEMEL BECERİ ÖLÇEĞİNİN TÜRKÇEYE UYARLAMA ÇALIŞMASI

THE ADAPTATION STUDY TO TURKISH OF BASIC PROCESS SKILLS SCALE TOWARDS PRIMARY STUDENTS

Bülent AYDOĞDU
Afyon Kocatepe Üniversitesi
baydogdu@aku.edu.tr

Fatih KARAKUŞ
Afyon Kocatepe Üniversitesi
fkarakus@aku.edu.tr

ÖZET: Bu çalışmanın amacı, ilkokul öğrencilerine yönelik Padilla, Cronin ve Twiest (1985) tarafından geliştirilen “Temel Beceri Ölçeği”ni Türkçeye uyarlamaktır. Temel Beceri Ölçeği, gözlem, sınıflama, çıkarım yapma, ölçme, tahmin ve iletişim kurma becerilerinin her birine yönelik altışar sorudan ve toplamda 36 sorudan oluşan çoktan seçmeli bir ölçektir. Ölçeğin uyarlaması çalışmasında, dil geçerliği için öncelikle ölçek, uzmanlar tarafından Türkçeye çevrilmiştir. Üç uzman çevirisinin ortak noktaları dikkate alınarak ortaya çıkan Türkçe taslak ölçekte yer alan maddeler bir dil uzmanı tarafından tekrar İngilizceye çevrilmiştir. Ölçeğin orijinali ile İngilizceye tekrar çevrilmiş hali karşılaştırılarak ölçeğe son hali verilmiştir. Bu aşamadan sonra Afyonkarahisar ilinde yer alan 6 farklı okulda öğrenim gören 447 ilkokul (3. 4. ve 5. sınıf) öğrencisine ölçek uygulanmıştır. İstatistiksel analiz için Finesse Paket Programı kullanılarak madde analizi yapılmış ve her sorunun madde güçlüğü ile ayırt edicilik indeksleri hesaplanmıştır. 36 maddeden oluşan bilimsel süreç becerileri ölçeğinin güvenilirlik katsayısı (KR–20) 0.81, ölçeğin ortalama güçlüğü ise 0.51 olarak belirlenmiştir. Dört sorunun ayırtıcılık indeksinin 0.20’nin altında olduğu görülmüş ve bu yüzden dört soru ölçekten çıkarılmıştır. Kalan 32 maddelik ölçeğin güvenilirliği (KR–20) 0.82 bulunmuştur.

Anahtar sözcükler: temel beceriler, ilkokul öğrencileri, bilimsel süreç becerileri, uyarlama çalışması

ABSTRACT: The current research aimed to adaptation to Turkish of “Test of Basic Process Skills-BAPS” developed by Padilla, Cronin ve Twiest (1985) towards primary students. Basic skills scale consist of 36-item multiple choice i.e. observation, inference, prediction, measurement, communication, and classification (each of six questions). The basic skills scale for language validity was translated into Turkish by 3 experts. Draft scale has been translated again into English by a language expert. The scale was translated again into English by comparing with the original version. The revised scale was administered to 3th, 4th, and 4th grade primary students (n=447) attending 6 different elementary schools in Afyonkarahisar. Item analysis was undertaken using the Finesse Package Program for statistical analysis. Moreover, item difficulty and distinctiveness indexes of each question were calculated. As a result, the reliability coefficient was found to be (KR–20) 0.81, and the mean difficulty was found to be 0.51 for the 36 item basic skills scale. Four of the questions were found to have a distinctiveness index below 0.20; therefore, it was excluded from the scale. The reliability for the scale with the remaining 32 items was found to be (KR–20) 0.82.

Key words: basic skills, primary students, science process skills, adaptation study

ÜNİVERSİTE ÖĞRENCİLERİNİN SOSYAL PAYLAŞIM SİTELERİNE YÖNELİK ALGILARININ İNCELENMESİ (FACEBOOK ÖRNEĞİ)

INVESTIGATION OF UNIVERSITY STUDENTS' PERCEPTION ABOUT SOCIAL NETWORK SITES

Ayşe İŞÇİOĞLU¹

Sinop Üniversitesi, Ayancık Meslek Yüksek Okulu, Sinop
akiyak@sinop.edu.tr

Doç. Dr. İsmail ŞAHİN

Necmettin Erbakan Üniversitesi, Ahmet Keleşoğlu Eğitim Fakültesi
isahin@konya.edu.tr

ÖZET: Sosyal iletişim ağları, kullanıcılara kendilerini yeniden tanımladıkları ve çeşitli sosyal ilişkilere katıldıkları bir kimlik alanı olarak yapılanmaktadır. Özellikle de üniversite öğrencileri tarafından çok değişik amaçla ve yaygın bir biçimde kullanılan sanal ortam, üniversite öğrencilerinin yaşamlarındaki psikolojik ve çevresel faktörlerden kaçınma, diğer taraftan, karşı cinsten yaşlıları ile yakın ilişkiler kurma eğilimleri onlar için sosyal medya kullanımını cazip kılmaktadır. Çalışmanın amacı üniversite öğrencilerinin Facebook algılarını incelemektir. Bu kapsamda, Facebook algıları arasındaki ilişkiler ve Facebook algılarının çeşitli değişkenlere göre farklılık gösterip göstermediği araştırılmıştır. Üniversite öğrencileri ile yapılan bu çalışmada Sinop Üniversitesi öğrencilerinden 180 kişiye anket formu uygulanmıştır. Üniversite gençlerinin, Facebook'a yönelik algıları bazı değişkenlere göre incelenmiş ve anlamlı farklılıklar bulunmuştur. Öncelikle genel frekans dağılımları dikkate alınarak değerlendirilmiştir. İki farklı grubun ortalamalarını karşılaştırmak için t-testi kullanılmıştır. Üniversite öğrencilerinin Facebook sosyal paylaşım sitesine üye olma nedenlerinin farklılık gösterip göstermediğini test etmek için tek yönlü varyans analizi kullanılmıştır. Aradaki farkın rastlantısal mı, yoksa istatistiksel olarak anlamlı mı olduğuna karar verilmiştir.

Anahtar Kelimeler: Üniversite Gençliği, Facebook, Sanal Medya, Sosyal Paylaşım.

SUMMARY

The social networks are constructed as an identification that the users define again themselves and participate to various social relations. According to university students, the social environment that is used commonly by university students is desirable to escape from psychological and environmental factors. The goal of this study investigates the Facebook sense of university students. Because of this aim, relation between the Facebook perceptions and whether the Facebook perceptions change according to various variables are searched. In this study, a survey is conducted to 180 students who are from the Sinop University. They are chosen between active Facebook users to get a good result. The Facebook perceptions of university students are examined as a basing on some variables which are gender, place where is accessed to internet, reason to join Facebook and so on. First of all, the general frequency is considered. The t-test is used to compare averages of the two groups. The one-way analysis of variance is used to test whether university students trust for internet, their reasons to use internet, their reasons to be a member of the Facebook are the same or not. Whether the differences coming from this analysis are accidental or statistically meaningful is decided.

Keywords: University Youth, Social Sharing, Facebook, Virtual Media.

GİRİŞ

¹ Not: Bu çalışma " Üniversite Öğrencilerinin Sosyal Paylaşım Sitelerine Yönelik Algılarının İncelenmesi" adlı yüksek lisans tezinden üretilmiştir.

Sosyal bir varlık olan insanın kendini ifade etme ve çevresi ile iletişim kurma ihtiyacı insanlık tarihi kadar eskidir. Bu ihtiyacın giderilmesinde ilk başvuru olan yol yüz yüze, birebir iletişimdir. Buna ek olarak zaman ve mekâna göre değişkenlik gösteren çeşitli argümanlarla da bu gereksinim karşılanmaya çalışılmıştır.

Son yıllarda bilgi ve iletişim teknolojileri ışığında birçok farklı alanda dönüşümler meydana geldiği gibi, sosyal yaşamı ve ortamı, sosyal iletişimi, sosyal ilişkileri kapsayan bir sosyal dönüşüm de yaşanmaktadır. Yaşanmaya devam eden bu dönüşüm teknolojiyi ve teknoloji kullanımını da etkilemektedir (Çoklar, 2010). Modern dünyanın ortaya çıkardığı değişen iletişim biçimleri ve teknolojilerinin bireyin ve yine bu bireylerin oluşturduğu toplum üzerindeki etkileri kendini birçok alanda göstermektedir. Bunların başında hiç şüphesiz iletişim teknolojileri gelmektedir. Günümüzde teknolojinin gelişimine paralel olarak yaygınlaşan bilgisayar kullanımı ve internet bilgiye ulaşmada en çok tercih edilen kullanım araçları olarak ön plana çıkmaktadır. Kullanımının basit olması, kolay erişilebilirliği, her kesimden insanın kendine göre bir ilgi alanı bulabilmesi, yaş, cinsiyet sınırlamalarının bulunmaması gibi nedenlerle kısa sürede geniş halk kitleleri tarafından benimsenmiş ve tahmin edilemeyen bir hızla dünya çapında yaygınlaşmıştır.

Sanal topluluklar insanlara yeni aidiyet alanları yaratmaktadır. Geleneksel topluluklardan büyük ölçüde farklı olan sanal topluluklar içinde insanlar, yalnızlıklarını paylaşacakları, içlerini dökebilecekleri ya da işleri ile ilgili sorunun çözülmesi konusunda yardım alabilecekleri yeni dostlar bulmaktadırlar (Robins, 1999). Sanal topluluklar sayesinde insanların yalnızlık duygusu hafiflemektedir. İnternet, bir taraftan kullanıcıları belirli bir kimliğe ve kültüre davet ederken bir taraftan da etkileşime olanak tanıyan yapısıyla, katılımcıların kendilerini yeniden tanımladıkları ve sosyal ilişkilere katıldıkları bir kimlik mekânı olarak karşımıza çıkmaktadır. Özellikle sitelerdeki sohbet (chat) odalarında ve arkadaş arama linklerinde kullanıcılar kendilerine yeni kimlikler oluşturarak sanal mekâna dâhil olmaktadır (Güzel, 2006).

Kitle iletişim teknolojisindeki gelişmeler, bilgi ve mesajları bütün insanlığa iletmelerine katkıda bulunmuştur. Farklı nedenlerle kapsama alanlarını dünyanın her yanına yaymak isteyen bireyler, küreselleşmenin iletişim ağlarının yoğunlaşması ile kendilerini ifade etme imkânı bulurlar. İletişim alanındaki bu gelişmeler yeni iletişim düzeni olarak tanımlanan bir durumun esasını oluşturmaktadır (Timisi, 2003). Ayrıca kitle iletişim teknolojisindeki karşı konulmaz gelişmeler kişinin bireysel ya da kendi akrabaları ile vakit geçirmesini kolaylaştırıcı etkenler olmuştur. Bu durum yeni sosyo-kültürel bağların ortaya çıkmasına, dolayısıyla bu insanların dini veya ruhçu birtakım gruplar içinde yer almasına ortam sağlamıştır (Arslan, 2006). Bu nedenle, iletişim belirli sınırlar içinde gerçekleşen bir etkinlik olma niteliğini aşmıştır. Yeni medya olarak tanımlanan teknolojiler, özellikle internet küresel bir düzen haline gelmiştir. Yaşanan gelişmeler, dönüşümler ve internetin sunduğu olanaklar, insanların ve özellikle gençlerin iletişim yollarını, sosyalleşme araçlarını ve çevrimiçi dünyadaki hareket alanlarını etkilemiştir. Sosyal etkileşim, iletişim ve bilgi edinme için öncü ve tercih edilen bir ortam haline gelen internet, genç insanların hayatında artan bir şekilde daha fazla yer bulmaktadır (Gemmil ve Peterson, 2006; Wang vd. 2010).

Araştırmanın Amacı

Yapılan çalışma ile üniversite öğrencilerinin Facebook algıları incelenmesi ve anlaşılması amaçlanmıştır. Bu kapsamda, Facebook algıları arasındaki ilişkiler ve Facebook algılarının çeşitli değişkenlere göre farklılık gösterip göstermediği araştırılmıştır. Bu amaç doğrultusunda aşağıdaki araştırma sorularına cevap aranmıştır.

Araştırma Soruları

1. Üniversite gençlerinin, Facebook'a yönelik algıları nedir?
2. Üniversite gençlerinin, Facebook'a yönelik algıları:
 - a. Cinsiyete,
 - b. Yaş aralığına göre,
 - c. Yaşadıkları yere göre farklılık,
 - d. İkamet ettikleri kişilere göre
 - e. Facebook'tan haberdar olma durumuna,
 - f. Facebook'a üyelik süresine göre,
 - g. Facebook'a üye olma nedenine,
 - h. İnterneti kullanım amaçlarına,
 - i. İnternete duydukları güvene göre farklılık göstermekte midir?

YÖNTEM

Bu bölümde sırasıyla araştırmanın modeli, evren ve örnekleme, veri toplama araçları, verilerin analizi yer almaktadır.

Araştırma Modeli

Bu araştırmada üniversite gençlerinin bir sosyal paylaşım sitesi olan Facebook'a yönelik algılarını belirlemek amacıyla nicel araştırma metodlarından tarama modeli kullanılmıştır. Tarama modelleri, geçmişte olmuş ya da hâlen var olan bir durumu, var olduğu biçimiyle betimlemeyi amaçlayan araştırma yaklaşımlarıdır. Araştırmaya konu olan birey ya da nesne, kendi koşulları içinde ve olduğu gibi tanımlanmaya çalışılır (Karasar, 2002).

Çalışma Grubu

Araştırmanın çalışma grubunu 2010-2011 öğretim yılı bahar döneminde Sinop Üniversitesinde öğrenim gören 17-25 yaş grubundaki.180 öğrenci oluşturmaktadır.

Veri Toplama Aracı

Veri toplama aracı olarak, Karakoç ve arkadaşları (2008) tarafından geliştirilen "Facebook Algı Ölçeği" kullanılmıştır.32 maddeden oluşan bu ölçek formunun ilk 20 maddesi beşli likert tipinde hazırlanmış ve seçenekler kesinlikle katılıyorum (1), katılıyorum (2), kararsızım (3), katılmıyorum (4), kesinlikle katılmıyorum (5) aralıklarında düzenlenmiştir. Geriye kalan 12 madde açık uçlu olarak sorulmuştur. Bunlara ek olarak yalnızca beş kapalı uçlu sorunun son maddesinde "diğer" seçeneğiyle birlikte, yanıtlayan kişinin ayrıntılı yazabileceği açık uç bırakılmıştır. Açık uç olarak kodlanan "diğer" seçenekli yanıtların bulunduğu sorularda, tüm seçenekler kapalı uçludur.

Anketin genel güvenilirliği Cronbach's Alpha değeri ile tesbit edilmiştir. Ölçeğin tamamı için hesaplanan Cronbach Alpha iç tutarlılık katsayısı 0.83 olarak bulunmuştur. Test için elde edilen güvenilirlik değerleri, ölçeklerde kabul edilen katsayı değeri olan 0.70'in üzerindedir. Ölçeğin tümünden ve faktörlerden elde edilen iç tutarlılık katsayılarının, güvenilirlik aralığına çok yakın ve ideal güvenilirlik değerinin üstünde olduğu görülmektedir (Creswell, 2005). Elde edilen güvenilirlik katsayıları, ölçeğin güvenilir olduğunu göstermektedir.

BULGULAR

Katılımcılara İlişkin Bulgular

Araştırmaya konu olan kitle hakkında daha sağlıklı yorumlarda bulunabilmek için örnekleme girenlerin; yaşları, cinsiyetleri, öğrenim görmekte oldukları fakülte-yüksekokul ve bölümleri gibi durumların bilinmesi bir zorunluluk arz etmektedir. Bu sebeple, bulgular kısmında, örneklemede yer alan bireylerin bu tür özellikleri öncelikli olarak ortaya konulmuş, bundan hareketle öteki değişkenlerin anlaşılmasına ve genel durumların aydınlatılmasına çalışılmıştır.

Şekil 1: Öğrencilerin Cinsiyet Dağılımı

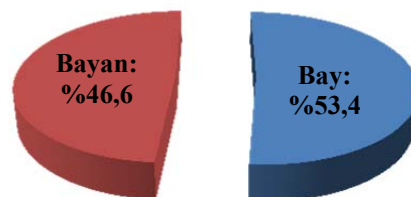

Şekil 1'de görüldüğü gibi, çalışmanın örneklemesini oluşturan öğrencilerin karakteristikleri incelendiğinde; araştırmaya katılan öğrencilerin % 53,4'ü bay (96), % 46,6'sı bayan (84) olduğu görülmektedir. Bu dağılımda bayan öğrenci sayısının erkek öğrenci sayısına yakın olması aranan verileri elde etme şansı açısından elverişli bir durumdur.

Kişilerin toplumsal konumlarını ve rollerini belirlemede yaş önemli bir faktör olarak görülmektedir. Ayrıca yaş faktörü, kişilerin sergiledikleri tutum ve davranışların anlaşılması ve anlamlandırılmasında da oldukça önemlidir. Bu çalışmada yaş faktörünün önemli bir unsur olarak ele alınabileceği düşünülmektedir.

Tablo 2'de araştırma kapsamındaki öğrencilerinin yaş durumuna göre dağılımları verilmektedir.

Tablo 2: Öğrencilerin Yaş Durumu

Yaş Durumu	Frekans	Yüzde
17-20	93	51,7
21-25	87	48,3
Toplam	180	100,0

Bu araştırmanın kapsamını üniversite öğrencileri oluşturduğundan, yaş aralığı çok geniş değildir. Tablo 2’de kullanıcıların genel olarak 17-25 yaş aralığında kümelendikleri görülmektedir.

Katılımcıların eğitim gördükleri fakülte ve yüksekokullara göre dağılımları şu şekildedir; 50 kişi (% 27,7) Fen-Edebiyat Fakültesi, 45 kişi (% 25) Eğitim Fakültesi, 25 kişi (% 13,8) Su Ürünleri Fakültesi, 60 kişi ise (% 33,3) Meslek Yüksekokulunda eğitim görmektedir.

Şekil 2: Öğrencilerin Öğrenim Gördükleri Fakülte ve Yüksekokul Türü

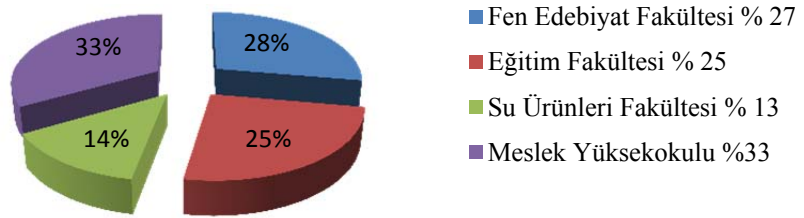

Bireylerin gelişim süreçleri, kişilik ve toplumsal statüleri, sosyalleştikleri kültürel ortamları, belirlemede yaşadıkları yerleşim birimleri önemli rol oynamaktadır. Bireyin bilinçaltında yer edinin ilerideki yaşlarda kişilik, davranış ve tutumlarını etkileyecek olan yaşantıların büyük bir kısmı; doğup büyüdüğü coğrafyada gerçekleşmektedirler. Bunun için, sosyolojik araştırmalarda bireylerin hayatlarının büyük kısmını geçirdikleri yerleşim birimlerinin incelenmesine ihtiyaç duyulmaktadır. Öğrencilerin, hayatlarının en büyük bölümünü geçirdikleri yerleşim birimlerine dair dağılım Tablo 3’te görülmektedir.

Tablo 3: Öğrencilerin En Uzun Süre Yaşadıkları Yerleşim Birimleri

Yerleşim Birimi	Frekans	Yüzde
Şehir	74	41,1
Taşra	106	58,9
Toplam	180	100,0

Tablo 3’te görüldüğü gibi, öğrencilerin büyük bir bölümü, şehirde yaşamışlardır.

Araştırmaya konu olan kitlenin Facebook kullanım alışkanlıklarının ve Facebook’un onların hayatlarındaki yerinin anlaşılmasında, aileleri ile birlikte aynı meskende birlikte yaşayıp yaşamadıkları, nasıl bir ortamda barındıkları ve kaldıkları mekânları kimlerle paylaştıkları gibi sorulara da cevap bulunması gerektiği düşünülmektedir. Öğrencilerin kimlerle yaşadıkları Tablo 4’te görüldüğü gibidir.

Tablo 4: Öğrencilerin Oturdukları Yer/İkamet Durumları

İkamet Ettiği Yer-Kişi	Frekans	Yüzde
Ailemle birlikte	62	34,4
Arkadaşlarımla birlikte	118	65,6
Toplam	180	100,0

Tablo 4'te görüldüğü gibi, öğrencilerin büyük bir kısmı arkadaşlarıyla birlikte kalmaktadır.

Tablo 5: Öğrencilerin Facebook Sosyal Paylaşım Sitesi İle Tanışma Durumlarının Dağılımı

Facebook Sosyal Paylaşım Sitesini İlk Nereden Duydunuz?	Frekans	Yüzde
Arkadaşlarımdan	118	65,6
Medyadan	72	34,4
Toplam	180	100,0

Üniversiteli gençlere Facebook sosyal paylaşım sitesini ilk nereden duydukları sorusu yöneltilmiştir. Tablo 5 incelendiğinde öğrencilerin % 65,6' sının arkadaşlarından , % 34,4'ü medyadan duyduklarını belirtmiştir.

Tablo 6: Öğrencilerin Facebook'a Üyelik Sürelerinin Dağılımı

Ne kadar zamandır Facebook Kullanıyorsunuz?	Frekans	Yüzde
1-2 yıl	82	45,6
3 yıl ve üzeri	98	54,4
Toplam	180	100,0

Tablo 6'deki verilere göre, üç yıl ve üzeri Facebook üyeliğine sahip kullanıcı oranı % 54,4 bir ya da iki yıldır kullanıcı hesabı olanların oranı % 45,6'dır. Veri dağılımından da anlaşıldığı üzere son 3 yıldan bu yana Facebook sosyal paylaşım sitesi kullanım oranı yüksektir.

MADDELER	Kesinlikle Katılıyorum		Katılıyorum		Kararsızım		Katılmıyorum		Kesinlikle Katılmıyorum	
	f	%	f	%	f	%	f	%	f	%
Eğlenceli içerikler sunuyor.	56	31,1	99	55,0	14	7,8	10	5,6	1	0,6
Eski arkadaşlarıma tekrar ulaşmamı sağlıyor.	97	53,9	75	41,7	2	1,1	5	2,8	1	0,6
Yaşadığım toplumu yansıtan bilgiler elde etmemi sağlıyor.	32	17,8	95	52,8	30	16,7	21	11,7	2	1,1
Merakımı gideriyor.	32	17,8	90	50,0	24	13,3	30	16,7	4	2,2
Kendimi ifade etmemi sağlıyor.	44	24,4	57	31,6	22	12,2	34	18,8	23	12,7
Bu tür siteleri kullanmak hoşuma gidiyor.	18	10,0	87	48,3	40	22,2	32	17,8	3	1,7
Boş zamanlarımı değerlendirmemi sağlıyor	33	18,3	91	50,6	21	11,7	28	15,6	7	3,9
İnsanlar arasında kolay fark edilmemi sağlıyor.	36	20,0	69	38,3	18	10,0	31	17,2	26	14,4
Aile üyeleri ve arkadaşlarla bir arada olmamızı sağlıyor.	41	22,8	80	44,4	16	8,9	34	18,9	9	5,0
Ders bilgilerimi paylaşmamı sağlıyor.	46	25,5	67	37,2	14	7,7	30	16,6	23	12,7
Gün içinde zaman geçirmeme yardımcı oluyor.	31	17,2	118	65,6	14	7,8	12	6,7	5	2,8
Kendi video ve fotoğraflarımı insanlarla paylaşmak hoşuma gidiyor.	28	15,6	69	38,3	22	12,2	52	28,9	9	5,0
Yeni insanlarla tanışmamı sağlıyor.	37	20,6	69	38,3	16	8,9	43	23,9	15	8,3
Sıkıntılarımı unutturuyor.	23	12,8	65	36,1	26	14,4	39	21,6	27	15,0
Gündemdeki gelişmeleri arkadaşlarımla paylaşmama yardımcı oluyor.	58	32,2	90	50,0	12	6,7	14	7,8	6	3,3
Arkadaşlarımın fotoğraflarına bakmak, hoşuma gidiyor.	48	26,7	91	50,6	21	11,7	18	10,0	2	1,1
Hoşça vakit geçiriyor.	23	12,8	99	55,0	29	16,1	27	15,0	2	1,1
Bir gruba aitmiş hissine kapılmamı sağlıyor.	28	15,5	64	35,5	27	15	33	18,3	28	15,5
Beni sıkın insanlardan kurtulmamı sağlıyor.	20	11,1	33	18,3	14	7,8	92	51,1	21	11,7
Oyun oynamamı sağlıyor	41	22,8	64	35,6	7	3,9	46	25,6	22	12,2

Üniversite Gençliğinin Facebook Algılarına İlişkin Bulgular

Tablo 7: Üniversite Öğrencilerinin Facebook Kullanma Eğilimlerine İlişkin Yüzde ve Frekans Değerleri

somutlaştırarak daha anlaşılır kılınmasını sağlamak için de bulgular frekans ve yüzde değerleri Tablo 7’de verilmiştir. Elde edilen bulgularla araştırmanın amacına yönelik sorulara cevap aranmıştır.

Araştırma Sorusu 1: Üniversite gençlerinin, Facebook’a yönelik algıları nedir?

“Facebook eğlenceli içerikler sunuyor.” maddesi öğrencilerin Facebook’u eğlenmek için ziyaret ettiklerini belirlemek amacıyla katılımcılara yöneltilmiştir. Tablo 7’de öğrencilerin vermiş olduğu yanıtların yüzdesine bakıldığında öğrencilerin % 86,1’inin bu görüşe katıldığı görülmektedir. Facebook’un içeriğinde yer alan oyun oynama, video, müzik paylaşımı ve gruplara katılım gibi çeşitli uygulamalar Facebook kullanıcıları tarafından eğlenceli bulunmaktadır.

“Facebook eski arkadaşlarıma ulaşmamı sağlıyor.” maddesine katılımcıların % 53,9’u kesinlikle katılıyorum ve % 41,7’si katılıyorum şikkını işaretlemiştir. Bulgular katılımcıların genel olarak aynı düşüncede olduklarını ortaya koymaktadır. Eski arkadaşlarını bulabilmek amacı ile Facebook’a üye olma nedeni de öğrenciler arasında yaygın olarak görülmektedir.

“Yaşadığım çevreyi, toplumu yansıtan bilgiler edinmemi sağlıyor” maddesinin sonuçlarına baktığımızda katılımcıların % 70,6’sı bu görüşe katıldıklarını beyan etmişlerdir. Aynı çevrede yaşayanların, kendileri gibi sanal ortamda olanlar ile bağlantı kurmada, çevre ve toplumu tanımada Facebook’tan yararlanmaktadır.

Tablo 7’ye bakıldığı zaman % 67,8 kişi Facebook içeriğinin meraklarını giderdiklerini belirtmiştir. Bu durum azımsanmayacak orandadır. Arkadaş listesinde yer alanların paylaşımına sunduğu etkinlikler fotoğraflar ve bunlara yapılan yorumlar hem kullanıcıların merakını gidermekte hem de keyifli zaman geçirmede tercih edilen bir seçenek olarak yer almaktadır.

“Facebook kendimi ifade etmemi sağlıyor” görüşüne katılan kullanıcı yüzdesi ile bu görüşü desteklemektedirler (% 56). Bu oran Facebook’un kullanıcılarına daha özgür ifade etme alanı sağladığını ortaya çıkarmaktadır. Günlük hayatta kendini ifade etmekte güçlük çeken utangaç, göz göze gelmekten çekinen bireyler Facebook’ta sanallığın verdiği güçle daha özgüvenlidirler. Bulgulardan elde edilen sonuçta bu görüşü desteklemektedir.

“Facebook boş zamanlarımı değerlendirmemi sağlıyor.” maddesi Tablo 7’de öğrencilerin vermiş olduğu yanıtların yüzdesine bakıldığında öğrencilerin % 98,6’ sı bu görüşü destekleyerek genel olarak azınlıkta olmadıklarını göstermektedirler. Bu sonuçtan yola çıkarak bireylerin Facebook’un sunmuş olduğu kültür ve entelektüel faaliyetlerle (oyun, chat üyelerin paylaştığı birbirinden farklı videolar ve birçok paylaşımlarla) boş zamanlarını değerlendirerek hoş vakit geçirdiklerini dile getirebiliriz.

Facebook “İnsanlar arasında daha kolay fark edilmeme imkân sağlıyor.” maddesine katılımcıların % 58,3’ü olumlu yanıt vermişlerdir. İnsan var oluşunun gereği olarak fark edilmek ister. Bunu da birçok bireyler Facebook aracılığıyla yerine getirmektedir.

“Facebook aile üyeleri ve arkadaşlarla bir arada olmamızı sağlıyor.” maddesine öğrencilerin % 67,2’si yakınları ile sanal ortamda bir araya geldiklerini, Facebook’u aile bireyleri veya arkadaşları ile buluşmaya ortam sağladığı için tercih ettikleri yorumunu yapabiliriz.

“Facebook ders bilgilerimi paylaşmamı sağlıyor” görüşüne öğrencilerin % 62,7’sinin katıldığı bulgular sonucu ortaya çıkmıştır. Kullanıcıların büyük bir bölümünü üniversite öğrencilerinin oluşturduğu Facebook, özellikle sağladığı aktif katılım ve işbirliği ile eğitsel bir ortam olarak kullanıma uygun olması nedeniyle öğrenme aracı olarak tercih edilmektedir.

Tablo 7’ye baktığımız zaman “Gün içinde zaman geçirmeme yardımcı oluyor” görüşüne % 82,8 kişinin katıldığı görülmektedir. Facebook hoşça zaman geçirmek isteyenler için tercih edilen bir sosyal paylaşım sitesidir.

Yapılan anket sonucundan “Facebook kendi video ve fotoğraflarımı insanlarla paylaşmak hoşuma gidiyor.” maddesine öğrencilerin % 53,9’unun katıldığı ortaya çıkmıştır. Bu durum internetteki videoların kullanıcılar açısından önemini ortaya koymaktadır.

Tablo 7’deki frekans sonucuna göre anket katılımcılarından % 58,9’u yeni arkadaşlara sıcak bakmaktadır. Bu durum insanların arkadaşına ve arkadaşlığına duydukları ihtiyacı Facebook’un karşıladığı ve tanımadığı kişilerle arkadaş olma konusunda tereddütlerinin olmadığı ortaya çıkarmaktadır. Bireyler Facebook kullanarak sadece belli gruplarla sınırlı kalmayıp, yeni insanlarla tanışma ve fikir paylaşımı olanağına sahip olmaktadır.

“Sıkıntılarımla unutturuyor” maddesine öğrencilerin % 48,9’unun katıldığı görülmektedir. Yukarıdaki Tablo 7’de görüldüğü gibi, öğrencilerin Facebook kullanmalarının en önemli sebeplerinden birinin, gündelik sorunlardan uzaklaşma isteği olduğunu ifade etmişlerdir. Burada Facebook’un kullanıcılar açısından rahatlama, dertleri öteleme gibi gerçek hayata alternatif bir çözüm aracı olarak da işlev görmektedir.

Tablo 7’ye bakıldığında öğrencilerin % 82,2 gibi büyük bir kısmının Facebook’u gündemdeki gelişmeleri arkadaşlarıyla paylaşma ve bu gelişmelerle ilgili düşüncelerini ifade etmek için kullandıkları gözlemlenmektedir. Bu orandan hareketle kullanıcıların çoğunun aktüel gelişmeleri diğerleriyle paylaşmak ve tartışmak için Facebook’tan yararlanmaktadır.

“Arkadaşlarının fotoğraflarına bakmak ve onların değişimlerini görmek hoşuma gidiyor” maddesi Facebook’un öğrenciler tarafından kullanılmasında görsel öğelerin kullanım biçimini ve kullanıcıların bundan ne kadar faydalandıklarının tespit edilmesi için katılımcılara yöneltilmiştir. Öğrencilerin % 77,3 ‘lük kısmı Facebook’u bu doğrultuda kullandıkları yönünde düşüncelerini ortaya koymuşlardır.

“Facebook hoşça vakit geçiriyor” düşüncesine öğrencilerin % 67,8’si katılmaktadır. Facebook diğer kişilerle iletişim kurma, bilgi alış-verişinde bulunma gibi daha çok ihtiyaç giderme amacının yanı sıra sunduğu bazı eğlenceli kullanım özellikleriyle de kullanıcılara hoşça vakit geçirtebiliyor. Kişiler eğlence zevklerine göre Facebook’un sunmuş olduğu alternatiflerden yararlanarak uzun süre online olabiliyorlar.

“Bir gruba aitmiş hissine kapılmamı sağlıyor” maddesi öğrencilerin sanal ortamda aidiyet hissi üzerinde Facebook’un etkisini saptamak amacıyla katılımcılara yöneltilmiştir. Bu noktada Facebook hangi alanda olursa olsun herkesin kendinden bir şeyler bulabileceği, çok değişik grupları bünyesinde barındırmaktadır. Tablo 7’ye bakıldığında kesinlikle katılıyorum ve katılıyorum diyenler aynı doğrultuda değerlendirildiğinde % 51,0 gibi bir oran bu düşüncenin açık destekleyicisi durumundadır.

“Beni sıkı insanlardan kurtulmamı sağlıyor” maddesine katılımcıların büyük bir çoğunluğu (% 62,8) bu görüşe katılmamaktadır. Bu durumda bireylerin kendisini sıkıldığını düşündüğü veya muhatap olmak istemediği kişilerden bir kaçış yeri olarak Facebook kullandıkları kanısına varmak doğru olmaz.

Araştırma Sorusu 2: Üniversite gençlerinin, Facebook’a yönelik algıları bazı değişkenlere göre farklılık göstermekte midir?

a) Üniversite gençlerinin cinsiyete göre Facebook’a yönelik algıları

Üniversite öğrencilerinin Facebook’a yönelik algılarının cinsiyet değişkeni yönünden bir fark gösterip göstermediği t-testi kullanılarak incelenmiş ve sonuçlar Tablo 8’de gösterilmiştir.

Tablo 8: Cinsiyet Değişkenine Göre t-Testi Sonuçları

	Cinsiyet	N	\bar{X}	S	t	p
Eğlenceli içerikler sunuyor.	Kız	84	3,95	,805	2,409	,017
	Erkek	96	4,24	,791		
Eski arkadaşlarıma tekrar ulaşmamı sağlıyor.	Kız	84	4,55	,568	1,669	,097
	Erkek	96	4,38	,811		
Yaşadığım çevreyi, toplumu yansıtan bilgiler elde etmemi sağlıyor.	Kız	84	3,70	,954	,571	,569
	Erkek	96	3,78	,897		
Merakımı gideriyor.	Kız	84	3,58	1,020	,745	,457
	Erkek	96	3,70	1,037		
Kendimi ifade etmemi sağlıyor.	Kız	84	2,89	1,193	2,105	,037
	Erkek	96	3,27	1,209		
Bu tür siteleri kullanmak hoşuma gidiyor.	Kız	84	3,32	,880	2,001	,047
	Erkek	96	3,60	1,000		
Boş zamanlarımı değerlendirmemi sağlıyor.	Kız	84	3,43	1,154	2,469	,015
	Erkek	96	3,82	,962		
İnsanlar arasında daha kolay fark edilmeme/tanışmama imkân sağlıyor.	Kız	84	2,74	1,272	2,024	,044
	Erkek	96	3,11	1,221		
Aile üyeleri ve arkadaşlarla bir arada olmamızı sağlıyor.	Kız	84	3,57	1,133	,423	,673
	Erkek	96	3,65	1,214		
Ders bilgilerimi paylaşmamı sağlıyor.	Kız	84	3,07	1,200	,008	,994
	Erkek	96	3,07	1,401		
Gün içinde zaman geçirmeme yardımcı oluyor.	Kız	84	3,79	,851	1,332	,185
	Erkek	96	3,96	,882		
Kendi video ve fotoğraflarımı insanlarla paylaşmak hoşuma gidiyor.	Kız	84	3,15	1,167	1,601	,111
	Erkek	96	3,44	1,195		

Yeni insanlarla tanışmamı sağlıyor.	Kız	84	2,89	1,252	5,179	,000
	Erkek	96	3,82	1,142		
Sıkıntılarımı unutturuyor.	Kız	84	2,92	1,224	,502	,616
	Erkek	96	2,82	1,273		
Gündemdeki gelişmeleri arkadaşlarımla paylaşmama/tartışmama yardımcı oluyor.	Kız	84	3,92	,934	1,043	,298
	Erkek	96	4,07	1,059		
Arkadaşlarının fotoğraflarına bakmak ve onların değişimlerini görmek hoşuma gidiyor.	Kız	84	3,89	,807	,317	,751
	Erkek	96	3,94	1,044		
Hoşça vakit geçiriyor.	Kız	84	3,43	,960	2,806	,006
	Erkek	96	3,81	,862		
Bir gruba aitmiş hissine kapılmama sağlıyor.	Kız	84	2,52	1,047	,531	,596
	Erkek	96	2,44	1,122		
Beni sıkın insanlardan kurtulmamı sağlıyor.	Kız	84	2,64	1,199	,187	,852
	Erkek	96	2,68	1,252		
Oyun oynamama yardımcı oluyor.	Kız	84	2,70	1,429	5,925	,000
	Erkek	96	3,84	1,108		

oyun oynamama yardımcı oluyor” fikrine % 58,4’ü katılırken % 37,8’i katılmamaktadır. Facebook’un içerdiği oyunları kullanıcıların büyük bir çoğunluğu tercih etmektedir. Facebook’ta geliştirilen çeşitli oyunlar sosyal ve interaktif özellikleri ile birlikte Facebook kullanıcılarının hem oyun oynayarak eğlendikleri hem de bu oyunlar vasıtasıyla etkileşime geçerek sosyalleştikleri bir aktivite haline gelmiştir.

Tablo 8 incelendiğinde, Facebook algı ölçeği “Eğlenceli içerikler sunuyor”, “Kendimi ifade etmemi sağlıyor.”, “Bu tür siteleri kullanmak hoşuma gidiyor.”, “Boş zamanlarımı değerlendirmemi sağlıyor.”, “İnsanlar arasında daha kolay fark edilmeme/tanışmama imkân sağlıyor.”, “Yeni insanlarla tanışmamı sağlıyor.”, “Hoşça vakit geçiriyor.”, “Oyun oynamama yardımcı oluyor.” maddelerinde cinsiyete göre Facebook’a yönelik algılarında anlamlı farklılık bulunmuştur. Anlamlı farklılık bulunan maddelerin hepsinde erkeklerin bayanlara göre Facebook’a yönelik algıları daha yüksektir. Diğer 12 maddede ise öğrencilerin cinsiyete göre Facebook algılarında anlamlı farklılık bulunmamıştır.

b) Üniversite gençlerinin yaş aralığına göre Facebook’a yönelik algıları

Üniversite öğrencilerinin Facebook’a yönelik algılarının yaş değişkeni yönünden bir fark gösterip göstermediği t-testi kullanılarak incelenmiş ve sonuçlar Tablo 9’da gösterilmiştir.

Tablo 9: Yaş Değişkenine Göre t-Testi Sonuçları

	Yaş	N	\bar{X}	S	t	p
Eğlenceli içerikler sunuyor.	17-20	93	4,10	,795	-,150	,881
	21-25	87	4,11	,827		
Eski arkadaşlarıma tekrar ulaşmamı sağlıyor.	17-20	93	4,51	,670	,971	,333
	21-25	87	4,40	,754		
Yaşadığım çevreyi, toplumu yansıtan bilgiler elde etmemi sağlıyor.	17-20	93	3,81	,912	,932	,352
	21-25	87	3,68	,934		
Merakımı gideriyor.	17-20	93	3,72	,937	1,019	,310
	21-25	87	3,56	1,118		
Kendimi ifade etmemi sağlıyor.	17-20	93	3,08	1,270	-,219	,827
	21-25	87	3,11	1,156		
Bu tür siteleri kullanmak hoşuma gidiyor.	17-20	93	3,52	,940	,637	,526
	21-25	87	3,43	,972		
Boş zamanlarımı değerlendirmemi sağlıyor.	17-20	93	3,70	1,081	,776	,439
	21-25	87	3,57	1,063		
İnsanlar arasında daha kolay fark edilmeme/tanışmama imkân sağlıyor.	17-20	93	3,08	1,218	1,512	,132
	21-25	87	2,79	1,286		
Aile üyeleri ve arkadaşlarla bir arada olmamızı sağlıyor.	17-20	93	3,70	1,081	1,032	,303
	21-25	87	3,52	1,265		
Ders bilgilerimi paylaşmamı sağlıyor.	17-20	93	3,17	1,248	1,059	,291
	21-25	87	2,97	1,368		
Gün içinde zaman geçirmeme yardımcı oluyor.	17-20	93	3,91	,830	,576	,526
	21-25	87	3,84	,913		
Kendi video ve fotoğraflarımı insanlarla paylaşmak hoşuma gidiyor.	17-20	93	3,38	1,141	,827	,410
	21-25	87	3,23	1,236		
Yeni insanlarla tanışmamı sağlıyor.	17-20	93	3,42	1,297	,330	,742
	21-25	87	3,36	1,267		
Sıkıntılarımı unutturuyor.	17-20	93	2,97	1,255	1,124	,262
	21-25	87	2,76	1,239		
Gündemdeki gelişmeleri arkadaşlarımla paylaşmama/tartışmama yardımcı oluyor.	17-20	93	4,06	,857	,884	,378
	21-25	87	3,93	1,139		
Arkadaşlarımın fotoğraflarına bakmak ve onların değişimlerini görmek hoşuma gidiyor.	17-20	93	3,99	,827	1,065	,289
	21-25	87	3,84	1,044		
Hoşça vakit geçiriyor.	17-20	93	3,68	,946	,659	,511
	21-25	87	3,59	,909		
Bir gruba aitmiş hissine kapılmamı sağlıyor	17-20	93	2,65	1,158	2,173	,031
	21-25	87	2,30	,978		
Beni sıkın insanlardan kurtulmamı sağlıyor.	17-20	93	2,74	1,250	,915	,361
	21-25	87	2,57	1,197		
Oyun oynamama yardımcı oluyor.	17-20	93	3,33	1,322	,222	,825
	21-25	87	3,29	1,462		

Tablo 9 incelendiğinde, Facebook algı ölçeği “Bir gruba aitmiş hissine kapılmamı sağlıyor” maddesinde yaşa göre Facebook’a yönelik algılarında anlamlı farklılık bulunmuştur. Diğer 19 maddede ise öğrencilerin yaşa göre Facebook algılarında anlamlı farklılık bulunmamıştır.

d) Üniversite gençlerinin yaşadıkları yere göre Facebook’a yönelik algıları

Tablo 10: Üniversite Gençlerinin Yaşadıkları Yere Göre t-Testi Sonuçları

	Yaşadığımız Yer	N	\bar{X}	S	t	p
Eğlenceli içerikler sunuyor.	Şehir	74	4,07	,865	,526	,600

	Taşra	106	4,13	,769		
Eski arkadaşlarıma tekrar ulaşmamı sağlıyor.	Şehir	74	4,51	,625	,913	,363
	Taşra	106	4,42	,767		
Yaşadığım çevreyi, toplumu yansıtan bilgiler elde etmemi sağlıyor.	Şehir	74	3,54	1,023	2,419	,017
	Taşra	106	3,89	,820		
Merakımı gideriyor.	Şehir	74	3,51	1,101	1,432	,154
	Taşra	106	3,74	,969		
Kendimi ifade etmemi sağlıyor	Şehir	74	2,88	1,238	2,014	,046
	Taşra	106	3,25	1,178		
Bu tür siteleri kullanmak hoşuma gidiyor.	Şehir	74	3,39	1,004	,944	,347
	Taşra	106	3,53	,918		
Boş zamanlarımı değerlendirmemi sağlıyor.	Şehir	74	3,55	1,195	,856	,393
	Taşra	106	3,70	,978		
İnsanlar arasında daha kolay fark edilmeme/tanışmama imkân sağlıyor.	Şehir	74	2,89	1,256	,419	,676
	Taşra	106	2,97	1,261		
Aile üyeleri ve arkadaşlarla bir arada olmamızı sağlıyor.	Şehir	74	3,55	1,184	,543	,588
	Taşra	106	3,65	1,171		
Ders bilgilerimi paylaşmamı sağlıyor.	Şehir	74	3,19	1,341	1,003	,317
	Taşra	106	2,99	1,284		
Gün içinde zaman geçirmeme yardımcı oluyor.	Şehir	74	3,82	,970	,688	,492
	Taşra	106	3,92	,794		
Kendi video ve fotoğraflarımı insanlarla paylaşmak hoşuma gidiyor.	Şehir	74	3,09	1,137	2,009	,046
	Taşra	106	3,45	1,204		
Yeni insanlarla tanışmamı sağlıyor.	Şehir	74	3,30	1,362	,802	,424
	Taşra	106	3,45	1,220		
Sıkıntılarımı unutturuyor.	Şehir	74	2,70	1,300	1,478	,141
	Taşra	106	2,98	1,203		
Gündemdeki gelişmeleri arkadaşlarımla paylaşmama/tartışmama yardımcı oluyor.	Şehir	74	4,00	1,020	,000	1,000
	Taşra	106	4,00	,995		
Arkadaşlarının fotoğraflarına bakmak ve onların değişimlerini görmek hoşuma gidiyor.	Şehir	74	3,92	,990	,027	,979
	Taşra	106	3,92	,906		
Hoşça vakit geçiriyor.	Şehir	74	3,47	1,037	1,879	,062
	Taşra	106	3,75	,829		
Bir gruba aitmiş hissine kapılmamı sağlıyor	Şehir	74	2,41	1,097	,746	,456
	Taşra	106	2,53	1,080		
Beni sıkın insanlardan kurtulmamı sağlıyor.	Şehir	74	2,46	1,125	1,901	,059
	Taşra	106	2,80	1,276		
Oyun oynamama yardımcı oluyor.	Şehir	74	3,15	1,496	1,283	,202
	Taşra	106	3,42	1,302		

Tablo 10 incelendiğinde, Facebook algı ölçeği “Yaşadığım çevreyi, toplumu yansıtan bilgiler elde etmemi sağlıyor.”, “Kendimi ifade etmemi sağlıyor.”, “Kendi video ve fotoğraflarımı insanlarla paylaşmak hoşuma gidiyor.” maddelerinde yaşanan yer değişkenine göre Facebook’a yönelik algılarında anlamlı farklılık bulunmuştur. Anlamlı farklılık bulunan bu maddelerde taşrada yaşayanların şehirde yaşayanlara göre Facebook’a yönelik algıları daha yüksektir. Diğer 17 maddede ise öğrencilerin Facebook’u ne zamandır kullandıklarına göre Facebook algılarında anlamlı farklılık bulunmamıştır.

e) Üniversite gençlerinin ikamet ettikleri kişilere göre Facebook’a yönelik algıları

Üniversite öğrencilerinin Facebook’a yönelik algıları ikamet ettikleri kişiler yönünden bir fark gösterip göstermediği t-testi kullanılarak incelenmiş ve sonuçlar Tablo 11’de gösterilmiştir.

Tablo 11: Üniversite Gençlerinin İkamet Ettikleri Kişilere Göre t-testi Sonuçları

	Kimlerle birlikte yaşıyorsunuz?	N	\bar{X}	S	t	p
Eğlenceli içerikler sunuyor.	Ailemle	62	4,05	,895		
	Arkadaşlarımla	118	4,14	,761		
Eski arkadaşlarıma tekrar ulaşmamı sağlıyor.	Ailemle	62	4,37	,773	1,157	,249
	Arkadaşlarımla	118	4,50	,676		
Yaşadığım çevreyi, toplumu yansıtan bilgiler elde etmemi sağlıyor.	Ailemle	62	3,66	,904		
	Arkadaşlarımla	118	3,79	,932		
Merakımı gideriyor.	Ailemle	62	3,56	1,002		
	Arkadaşlarımla	118	3,69	1,043		
Kendimi ifade etmemi sağlıyor	Ailemle	62	3,16	1,176		
	Arkadaşlarımla	118	3,06	1,235		
Bu tür siteleri kullanmak hoşuma gidiyor.	Ailemle	62	3,52	,971		
	Arkadaşlarımla	118	3,45	,948		
Boş zamanlarımı değerlendirmemi sağlıyor.	Ailemle	62	3,66	1,007		
	Arkadaşlarımla	118	3,63	1,108		
İnsanlar arasında daha kolay fark edilmeme/tanışmama imkân sağlıyor.	Ailemle	62	3,05	1,247		
	Arkadaşlarımla	118	2,88	1,262		
Aile üyeleri ve arkadaşlarla bir arada olmamızı sağlıyor.	Ailemle	62	3,55	1,197		
	Arkadaşlarımla	118	3,64	1,166		
Ders bilgilerimi paylaşmamı sağlıyor.	Ailemle	62	2,81	1,329	1,993	,048
	Arkadaşlarımla	118	3,21	1,280		
Gün içinde zaman geçirmeme yardımcı oluyor.	Ailemle	62	4,00	,747	1,464	
	Arkadaşlarımla	118	3,81	,924		
Kendi video ve fotoğraflarımı insanlarla paylaşmak hoşuma gidiyor.	Ailemle	62	3,26	1,173		
	Arkadaşlarımla	118	3,33	1,199		
Yeni insanlarla tanışmamı sağlıyor.	Ailemle	62	3,55	1,237	1,214	
	Arkadaşlarımla	118	3,31	1,298		
Sıkıntılarımı unutturuyor.	Ailemle	62	2,82	1,274		
	Arkadaşlarımla	118	2,89	1,239		
Gündemdeki gelişmeleri arkadaşlarımla paylaşmama/tartışmama yardımcı oluyor.	Ailemle	62	3,98	1,138		
	Arkadaşlarımla	118	4,01	,929		
Arkadaşlarımla fotoğraflarına bakmak ve onların değişimlerini görmek hoşuma gidiyor.	Ailemle	62	3,89	1,088		
	Arkadaşlarımla	118	3,93	,855		
Hoşça vakit geçiriyor.	Ailemle	62	3,65	,889		
	Arkadaşlarımla	118	3,63	,950		
Bir gruba aitmiş hissine kapılmamı sağlıyor	Ailemle	62	2,63	1,149		
	Arkadaşlarımla	118	2,40	1,047		
Beni sıkın insanlardan kurtulmamı sağlıyor.	Ailemle	62	2,71	1,285		
	Arkadaşlarımla	118	2,64	1,196		
Oyun oynamama yardımcı oluyor.	Ailemle	62	3,50	1,376	1,327	
	Arkadaşlarımla	118	3,21	1,389		

Tablo 11 incelendiğinde, Facebook algı ölçeği “Ders bilgilerimi paylaşmamı sağlıyor.” maddesinde kimlerle yaşadıklarına göre Facebook’a yönelik algılarında anlamlı farklılık bulunmuştur. Anlamlı farklılık bulunan bu maddede arkadaşlarıyla yaşayanların ailesiyle yaşayanlara göre Facebook’a yönelik algıları daha yüksektir. Diğer 19 maddede ise öğrencilerin yaşadıkları kişilere göre Facebook algılarında anlamlı farklılık bulunmamıştır.

f) Üniversite gençlerinin Facebook'tan haberdar olma durumuna göre Facebook'a yönelik algıları

Üniversite öğrencilerinin Facebook'a yönelik algılarının Facebook'tan haberdar olma değişkeni yönünden bir fark gösterip göstermediği t-testi kullanılarak incelenmiş ve sonuçlar Tablo 12'de gösterilmiştir.

Tablo 12: Facebook'tan Haberdar Olma Durumuna Göre t-Testi Sonuçları

	Facebook'u ilk nereden duydunuz?	N	\bar{X}	S	t	p																																																																																																																																																																																																														
Eğlenceli içerikler sunuyor.	Arkadaşımdan	118	4,12	,786	,299	,765																																																																																																																																																																																																														
	Medya	62	4,08	,855			Eski arkadaşlarıma tekrar ulaşmamı sağlıyor.	Arkadaşımdan	118	4,42	,697	,827	,409	Medya	62	4,52	,741	Yaşadığım çevreyi, toplumu yansıtan bilgiler elde etmemi sağlıyor.	Arkadaşımdan	118	3,64	,893	2,208	,029	Medya	62	3,95	,948	Merakımı gideriyor.	Arkadaşımdan	118	3,61	1,086	,650	,517	Medya	62	3,71	,912	Kendimi ifade etmemi sağlıyor	Arkadaşımdan	118	3,07	1,203	,406	,685	Medya	62	3,15	1,239	Bu tür siteleri kullanmak hoşuma gidiyor.	Arkadaşımdan	118	3,42	,982	,941	,348	Medya	62	3,56	,898	Boş zamanlarımı değerlendirmemi sağlıyor.	Arkadaşımdan	118	3,62	1,053	,349	,728	Medya	62	3,68	1,113	İnsanlar arasında daha kolay fark edilmeme/tanışmama imkân sağlıyor.	Arkadaşımdan	118	2,94	1,200	,026	,979	Medya	62	2,94	1,366	Aile üyeleri ve arkadaşlarla bir arada olmamızı sağlıyor.	Arkadaşımdan	118	3,62	1,198	,118	,906	Medya	62	3,60	1,137	Ders bilgilerimi paylaşmamı sağlıyor.	Arkadaşımdan	118	3,13	1,291	,776	,439	Medya	62	2,97	1,342	Gün içinde zaman geçirmeme yardımcı oluyor.	Arkadaşımdan	118	3,84	,906	,825	,410	Medya	62	3,95	,798	Kendi video ve fotoğraflarımı insanlarla paylaşmak hoşuma gidiyor.	Arkadaşımdan	118	3,31	1,202	,007	,994	Medya	62	3,31	1,168	Yeni insanlarla tanışmamı sağlıyor.	Arkadaşımdan	118	3,41	1,262	,258	,797	Medya	62	3,35	1,319	Sıkıntılarımı unutturuyor.	Arkadaşımdan	118	2,82	1,252	,661	,510	Medya	62	2,95	1,247	Gündemdeki gelişmeleri arkadaşlarımla paylaşmama/tartışmama yardımcı oluyor.	Arkadaşımdan	118	3,95	1,036	,938	,349	Medya	62	4,10	,936	Arkadaşlarının fotoğraflarına bakmak ve onların değişimlerini görmek hoşuma gidiyor.	Arkadaşımdan	118	3,88	,944	-,695	,488	Medya	62	3,98	,932	Hoşça vakit geçiriyor.	Arkadaşımdan	118	3,64	,901	,214	,831	Medya	62	3,61	,981	Bir gruba aitmiş hissine kapılmamı sağlıyor	Arkadaşımdan	118	2,47	1,027	,054	,957	Medya	62	2,48	1,198	Beni sıkın insanlardan kurtulmamı sağlıyor.	Arkadaşımdan	118	2,72	1,212	,895	,372	Medya	62	2,55	1,250	Oyun oynamama yardımcı oluyor.	Arkadaşımdan	118	3,37	1,370	,823	,411	Medya
Eski arkadaşlarıma tekrar ulaşmamı sağlıyor.	Arkadaşımdan	118	4,42	,697	,827	,409																																																																																																																																																																																																														
	Medya	62	4,52	,741			Yaşadığım çevreyi, toplumu yansıtan bilgiler elde etmemi sağlıyor.	Arkadaşımdan	118	3,64	,893	2,208	,029	Medya	62	3,95	,948	Merakımı gideriyor.	Arkadaşımdan	118	3,61	1,086	,650	,517	Medya	62	3,71	,912	Kendimi ifade etmemi sağlıyor	Arkadaşımdan	118	3,07	1,203	,406	,685	Medya	62	3,15	1,239	Bu tür siteleri kullanmak hoşuma gidiyor.	Arkadaşımdan	118	3,42	,982	,941	,348	Medya	62	3,56	,898	Boş zamanlarımı değerlendirmemi sağlıyor.	Arkadaşımdan	118	3,62	1,053	,349	,728	Medya	62	3,68	1,113	İnsanlar arasında daha kolay fark edilmeme/tanışmama imkân sağlıyor.	Arkadaşımdan	118	2,94	1,200	,026	,979	Medya	62	2,94	1,366	Aile üyeleri ve arkadaşlarla bir arada olmamızı sağlıyor.	Arkadaşımdan	118	3,62	1,198	,118	,906	Medya	62	3,60	1,137	Ders bilgilerimi paylaşmamı sağlıyor.	Arkadaşımdan	118	3,13	1,291	,776	,439	Medya	62	2,97	1,342	Gün içinde zaman geçirmeme yardımcı oluyor.	Arkadaşımdan	118	3,84	,906	,825	,410	Medya	62	3,95	,798	Kendi video ve fotoğraflarımı insanlarla paylaşmak hoşuma gidiyor.	Arkadaşımdan	118	3,31	1,202	,007	,994	Medya	62	3,31	1,168	Yeni insanlarla tanışmamı sağlıyor.	Arkadaşımdan	118	3,41	1,262	,258	,797	Medya	62	3,35	1,319	Sıkıntılarımı unutturuyor.	Arkadaşımdan	118	2,82	1,252	,661	,510	Medya	62	2,95	1,247	Gündemdeki gelişmeleri arkadaşlarımla paylaşmama/tartışmama yardımcı oluyor.	Arkadaşımdan	118	3,95	1,036	,938	,349	Medya	62	4,10	,936	Arkadaşlarının fotoğraflarına bakmak ve onların değişimlerini görmek hoşuma gidiyor.	Arkadaşımdan	118	3,88	,944	-,695	,488	Medya	62	3,98	,932	Hoşça vakit geçiriyor.	Arkadaşımdan	118	3,64	,901	,214	,831	Medya	62	3,61	,981	Bir gruba aitmiş hissine kapılmamı sağlıyor	Arkadaşımdan	118	2,47	1,027	,054	,957	Medya	62	2,48	1,198	Beni sıkın insanlardan kurtulmamı sağlıyor.	Arkadaşımdan	118	2,72	1,212	,895	,372	Medya	62	2,55	1,250	Oyun oynamama yardımcı oluyor.	Arkadaşımdan	118	3,37	1,370	,823	,411	Medya	62	3,19	1,424								
Yaşadığım çevreyi, toplumu yansıtan bilgiler elde etmemi sağlıyor.	Arkadaşımdan	118	3,64	,893	2,208	,029																																																																																																																																																																																																														
	Medya	62	3,95	,948			Merakımı gideriyor.	Arkadaşımdan	118	3,61	1,086	,650	,517	Medya	62	3,71	,912	Kendimi ifade etmemi sağlıyor	Arkadaşımdan	118	3,07	1,203	,406	,685	Medya	62	3,15	1,239	Bu tür siteleri kullanmak hoşuma gidiyor.	Arkadaşımdan	118	3,42	,982	,941	,348	Medya	62	3,56	,898	Boş zamanlarımı değerlendirmemi sağlıyor.	Arkadaşımdan	118	3,62	1,053	,349	,728	Medya	62	3,68	1,113	İnsanlar arasında daha kolay fark edilmeme/tanışmama imkân sağlıyor.	Arkadaşımdan	118	2,94	1,200	,026	,979	Medya	62	2,94	1,366	Aile üyeleri ve arkadaşlarla bir arada olmamızı sağlıyor.	Arkadaşımdan	118	3,62	1,198	,118	,906	Medya	62	3,60	1,137	Ders bilgilerimi paylaşmamı sağlıyor.	Arkadaşımdan	118	3,13	1,291	,776	,439	Medya	62	2,97	1,342	Gün içinde zaman geçirmeme yardımcı oluyor.	Arkadaşımdan	118	3,84	,906	,825	,410	Medya	62	3,95	,798	Kendi video ve fotoğraflarımı insanlarla paylaşmak hoşuma gidiyor.	Arkadaşımdan	118	3,31	1,202	,007	,994	Medya	62	3,31	1,168	Yeni insanlarla tanışmamı sağlıyor.	Arkadaşımdan	118	3,41	1,262	,258	,797	Medya	62	3,35	1,319	Sıkıntılarımı unutturuyor.	Arkadaşımdan	118	2,82	1,252	,661	,510	Medya	62	2,95	1,247	Gündemdeki gelişmeleri arkadaşlarımla paylaşmama/tartışmama yardımcı oluyor.	Arkadaşımdan	118	3,95	1,036	,938	,349	Medya	62	4,10	,936	Arkadaşlarının fotoğraflarına bakmak ve onların değişimlerini görmek hoşuma gidiyor.	Arkadaşımdan	118	3,88	,944	-,695	,488	Medya	62	3,98	,932	Hoşça vakit geçiriyor.	Arkadaşımdan	118	3,64	,901	,214	,831	Medya	62	3,61	,981	Bir gruba aitmiş hissine kapılmamı sağlıyor	Arkadaşımdan	118	2,47	1,027	,054	,957	Medya	62	2,48	1,198	Beni sıkın insanlardan kurtulmamı sağlıyor.	Arkadaşımdan	118	2,72	1,212	,895	,372	Medya	62	2,55	1,250	Oyun oynamama yardımcı oluyor.	Arkadaşımdan	118	3,37	1,370	,823	,411	Medya	62	3,19	1,424																			
Merakımı gideriyor.	Arkadaşımdan	118	3,61	1,086	,650	,517																																																																																																																																																																																																														
	Medya	62	3,71	,912			Kendimi ifade etmemi sağlıyor	Arkadaşımdan	118	3,07	1,203	,406	,685	Medya	62	3,15	1,239	Bu tür siteleri kullanmak hoşuma gidiyor.	Arkadaşımdan	118	3,42	,982	,941	,348	Medya	62	3,56	,898	Boş zamanlarımı değerlendirmemi sağlıyor.	Arkadaşımdan	118	3,62	1,053	,349	,728	Medya	62	3,68	1,113	İnsanlar arasında daha kolay fark edilmeme/tanışmama imkân sağlıyor.	Arkadaşımdan	118	2,94	1,200	,026	,979	Medya	62	2,94	1,366	Aile üyeleri ve arkadaşlarla bir arada olmamızı sağlıyor.	Arkadaşımdan	118	3,62	1,198	,118	,906	Medya	62	3,60	1,137	Ders bilgilerimi paylaşmamı sağlıyor.	Arkadaşımdan	118	3,13	1,291	,776	,439	Medya	62	2,97	1,342	Gün içinde zaman geçirmeme yardımcı oluyor.	Arkadaşımdan	118	3,84	,906	,825	,410	Medya	62	3,95	,798	Kendi video ve fotoğraflarımı insanlarla paylaşmak hoşuma gidiyor.	Arkadaşımdan	118	3,31	1,202	,007	,994	Medya	62	3,31	1,168	Yeni insanlarla tanışmamı sağlıyor.	Arkadaşımdan	118	3,41	1,262	,258	,797	Medya	62	3,35	1,319	Sıkıntılarımı unutturuyor.	Arkadaşımdan	118	2,82	1,252	,661	,510	Medya	62	2,95	1,247	Gündemdeki gelişmeleri arkadaşlarımla paylaşmama/tartışmama yardımcı oluyor.	Arkadaşımdan	118	3,95	1,036	,938	,349	Medya	62	4,10	,936	Arkadaşlarının fotoğraflarına bakmak ve onların değişimlerini görmek hoşuma gidiyor.	Arkadaşımdan	118	3,88	,944	-,695	,488	Medya	62	3,98	,932	Hoşça vakit geçiriyor.	Arkadaşımdan	118	3,64	,901	,214	,831	Medya	62	3,61	,981	Bir gruba aitmiş hissine kapılmamı sağlıyor	Arkadaşımdan	118	2,47	1,027	,054	,957	Medya	62	2,48	1,198	Beni sıkın insanlardan kurtulmamı sağlıyor.	Arkadaşımdan	118	2,72	1,212	,895	,372	Medya	62	2,55	1,250	Oyun oynamama yardımcı oluyor.	Arkadaşımdan	118	3,37	1,370	,823	,411	Medya	62	3,19	1,424																														
Kendimi ifade etmemi sağlıyor	Arkadaşımdan	118	3,07	1,203	,406	,685																																																																																																																																																																																																														
	Medya	62	3,15	1,239			Bu tür siteleri kullanmak hoşuma gidiyor.	Arkadaşımdan	118	3,42	,982	,941	,348	Medya	62	3,56	,898	Boş zamanlarımı değerlendirmemi sağlıyor.	Arkadaşımdan	118	3,62	1,053	,349	,728	Medya	62	3,68	1,113	İnsanlar arasında daha kolay fark edilmeme/tanışmama imkân sağlıyor.	Arkadaşımdan	118	2,94	1,200	,026	,979	Medya	62	2,94	1,366	Aile üyeleri ve arkadaşlarla bir arada olmamızı sağlıyor.	Arkadaşımdan	118	3,62	1,198	,118	,906	Medya	62	3,60	1,137	Ders bilgilerimi paylaşmamı sağlıyor.	Arkadaşımdan	118	3,13	1,291	,776	,439	Medya	62	2,97	1,342	Gün içinde zaman geçirmeme yardımcı oluyor.	Arkadaşımdan	118	3,84	,906	,825	,410	Medya	62	3,95	,798	Kendi video ve fotoğraflarımı insanlarla paylaşmak hoşuma gidiyor.	Arkadaşımdan	118	3,31	1,202	,007	,994	Medya	62	3,31	1,168	Yeni insanlarla tanışmamı sağlıyor.	Arkadaşımdan	118	3,41	1,262	,258	,797	Medya	62	3,35	1,319	Sıkıntılarımı unutturuyor.	Arkadaşımdan	118	2,82	1,252	,661	,510	Medya	62	2,95	1,247	Gündemdeki gelişmeleri arkadaşlarımla paylaşmama/tartışmama yardımcı oluyor.	Arkadaşımdan	118	3,95	1,036	,938	,349	Medya	62	4,10	,936	Arkadaşlarının fotoğraflarına bakmak ve onların değişimlerini görmek hoşuma gidiyor.	Arkadaşımdan	118	3,88	,944	-,695	,488	Medya	62	3,98	,932	Hoşça vakit geçiriyor.	Arkadaşımdan	118	3,64	,901	,214	,831	Medya	62	3,61	,981	Bir gruba aitmiş hissine kapılmamı sağlıyor	Arkadaşımdan	118	2,47	1,027	,054	,957	Medya	62	2,48	1,198	Beni sıkın insanlardan kurtulmamı sağlıyor.	Arkadaşımdan	118	2,72	1,212	,895	,372	Medya	62	2,55	1,250	Oyun oynamama yardımcı oluyor.	Arkadaşımdan	118	3,37	1,370	,823	,411	Medya	62	3,19	1,424																																									
Bu tür siteleri kullanmak hoşuma gidiyor.	Arkadaşımdan	118	3,42	,982	,941	,348																																																																																																																																																																																																														
	Medya	62	3,56	,898			Boş zamanlarımı değerlendirmemi sağlıyor.	Arkadaşımdan	118	3,62	1,053	,349	,728	Medya	62	3,68	1,113	İnsanlar arasında daha kolay fark edilmeme/tanışmama imkân sağlıyor.	Arkadaşımdan	118	2,94	1,200	,026	,979	Medya	62	2,94	1,366	Aile üyeleri ve arkadaşlarla bir arada olmamızı sağlıyor.	Arkadaşımdan	118	3,62	1,198	,118	,906	Medya	62	3,60	1,137	Ders bilgilerimi paylaşmamı sağlıyor.	Arkadaşımdan	118	3,13	1,291	,776	,439	Medya	62	2,97	1,342	Gün içinde zaman geçirmeme yardımcı oluyor.	Arkadaşımdan	118	3,84	,906	,825	,410	Medya	62	3,95	,798	Kendi video ve fotoğraflarımı insanlarla paylaşmak hoşuma gidiyor.	Arkadaşımdan	118	3,31	1,202	,007	,994	Medya	62	3,31	1,168	Yeni insanlarla tanışmamı sağlıyor.	Arkadaşımdan	118	3,41	1,262	,258	,797	Medya	62	3,35	1,319	Sıkıntılarımı unutturuyor.	Arkadaşımdan	118	2,82	1,252	,661	,510	Medya	62	2,95	1,247	Gündemdeki gelişmeleri arkadaşlarımla paylaşmama/tartışmama yardımcı oluyor.	Arkadaşımdan	118	3,95	1,036	,938	,349	Medya	62	4,10	,936	Arkadaşlarının fotoğraflarına bakmak ve onların değişimlerini görmek hoşuma gidiyor.	Arkadaşımdan	118	3,88	,944	-,695	,488	Medya	62	3,98	,932	Hoşça vakit geçiriyor.	Arkadaşımdan	118	3,64	,901	,214	,831	Medya	62	3,61	,981	Bir gruba aitmiş hissine kapılmamı sağlıyor	Arkadaşımdan	118	2,47	1,027	,054	,957	Medya	62	2,48	1,198	Beni sıkın insanlardan kurtulmamı sağlıyor.	Arkadaşımdan	118	2,72	1,212	,895	,372	Medya	62	2,55	1,250	Oyun oynamama yardımcı oluyor.	Arkadaşımdan	118	3,37	1,370	,823	,411	Medya	62	3,19	1,424																																																				
Boş zamanlarımı değerlendirmemi sağlıyor.	Arkadaşımdan	118	3,62	1,053	,349	,728																																																																																																																																																																																																														
	Medya	62	3,68	1,113			İnsanlar arasında daha kolay fark edilmeme/tanışmama imkân sağlıyor.	Arkadaşımdan	118	2,94	1,200	,026	,979	Medya	62	2,94	1,366	Aile üyeleri ve arkadaşlarla bir arada olmamızı sağlıyor.	Arkadaşımdan	118	3,62	1,198	,118	,906	Medya	62	3,60	1,137	Ders bilgilerimi paylaşmamı sağlıyor.	Arkadaşımdan	118	3,13	1,291	,776	,439	Medya	62	2,97	1,342	Gün içinde zaman geçirmeme yardımcı oluyor.	Arkadaşımdan	118	3,84	,906	,825	,410	Medya	62	3,95	,798	Kendi video ve fotoğraflarımı insanlarla paylaşmak hoşuma gidiyor.	Arkadaşımdan	118	3,31	1,202	,007	,994	Medya	62	3,31	1,168	Yeni insanlarla tanışmamı sağlıyor.	Arkadaşımdan	118	3,41	1,262	,258	,797	Medya	62	3,35	1,319	Sıkıntılarımı unutturuyor.	Arkadaşımdan	118	2,82	1,252	,661	,510	Medya	62	2,95	1,247	Gündemdeki gelişmeleri arkadaşlarımla paylaşmama/tartışmama yardımcı oluyor.	Arkadaşımdan	118	3,95	1,036	,938	,349	Medya	62	4,10	,936	Arkadaşlarının fotoğraflarına bakmak ve onların değişimlerini görmek hoşuma gidiyor.	Arkadaşımdan	118	3,88	,944	-,695	,488	Medya	62	3,98	,932	Hoşça vakit geçiriyor.	Arkadaşımdan	118	3,64	,901	,214	,831	Medya	62	3,61	,981	Bir gruba aitmiş hissine kapılmamı sağlıyor	Arkadaşımdan	118	2,47	1,027	,054	,957	Medya	62	2,48	1,198	Beni sıkın insanlardan kurtulmamı sağlıyor.	Arkadaşımdan	118	2,72	1,212	,895	,372	Medya	62	2,55	1,250	Oyun oynamama yardımcı oluyor.	Arkadaşımdan	118	3,37	1,370	,823	,411	Medya	62	3,19	1,424																																																															
İnsanlar arasında daha kolay fark edilmeme/tanışmama imkân sağlıyor.	Arkadaşımdan	118	2,94	1,200	,026	,979																																																																																																																																																																																																														
	Medya	62	2,94	1,366			Aile üyeleri ve arkadaşlarla bir arada olmamızı sağlıyor.	Arkadaşımdan	118	3,62	1,198	,118	,906	Medya	62	3,60	1,137	Ders bilgilerimi paylaşmamı sağlıyor.	Arkadaşımdan	118	3,13	1,291	,776	,439	Medya	62	2,97	1,342	Gün içinde zaman geçirmeme yardımcı oluyor.	Arkadaşımdan	118	3,84	,906	,825	,410	Medya	62	3,95	,798	Kendi video ve fotoğraflarımı insanlarla paylaşmak hoşuma gidiyor.	Arkadaşımdan	118	3,31	1,202	,007	,994	Medya	62	3,31	1,168	Yeni insanlarla tanışmamı sağlıyor.	Arkadaşımdan	118	3,41	1,262	,258	,797	Medya	62	3,35	1,319	Sıkıntılarımı unutturuyor.	Arkadaşımdan	118	2,82	1,252	,661	,510	Medya	62	2,95	1,247	Gündemdeki gelişmeleri arkadaşlarımla paylaşmama/tartışmama yardımcı oluyor.	Arkadaşımdan	118	3,95	1,036	,938	,349	Medya	62	4,10	,936	Arkadaşlarının fotoğraflarına bakmak ve onların değişimlerini görmek hoşuma gidiyor.	Arkadaşımdan	118	3,88	,944	-,695	,488	Medya	62	3,98	,932	Hoşça vakit geçiriyor.	Arkadaşımdan	118	3,64	,901	,214	,831	Medya	62	3,61	,981	Bir gruba aitmiş hissine kapılmamı sağlıyor	Arkadaşımdan	118	2,47	1,027	,054	,957	Medya	62	2,48	1,198	Beni sıkın insanlardan kurtulmamı sağlıyor.	Arkadaşımdan	118	2,72	1,212	,895	,372	Medya	62	2,55	1,250	Oyun oynamama yardımcı oluyor.	Arkadaşımdan	118	3,37	1,370	,823	,411	Medya	62	3,19	1,424																																																																										
Aile üyeleri ve arkadaşlarla bir arada olmamızı sağlıyor.	Arkadaşımdan	118	3,62	1,198	,118	,906																																																																																																																																																																																																														
	Medya	62	3,60	1,137			Ders bilgilerimi paylaşmamı sağlıyor.	Arkadaşımdan	118	3,13	1,291	,776	,439	Medya	62	2,97	1,342	Gün içinde zaman geçirmeme yardımcı oluyor.	Arkadaşımdan	118	3,84	,906	,825	,410	Medya	62	3,95	,798	Kendi video ve fotoğraflarımı insanlarla paylaşmak hoşuma gidiyor.	Arkadaşımdan	118	3,31	1,202	,007	,994	Medya	62	3,31	1,168	Yeni insanlarla tanışmamı sağlıyor.	Arkadaşımdan	118	3,41	1,262	,258	,797	Medya	62	3,35	1,319	Sıkıntılarımı unutturuyor.	Arkadaşımdan	118	2,82	1,252	,661	,510	Medya	62	2,95	1,247	Gündemdeki gelişmeleri arkadaşlarımla paylaşmama/tartışmama yardımcı oluyor.	Arkadaşımdan	118	3,95	1,036	,938	,349	Medya	62	4,10	,936	Arkadaşlarının fotoğraflarına bakmak ve onların değişimlerini görmek hoşuma gidiyor.	Arkadaşımdan	118	3,88	,944	-,695	,488	Medya	62	3,98	,932	Hoşça vakit geçiriyor.	Arkadaşımdan	118	3,64	,901	,214	,831	Medya	62	3,61	,981	Bir gruba aitmiş hissine kapılmamı sağlıyor	Arkadaşımdan	118	2,47	1,027	,054	,957	Medya	62	2,48	1,198	Beni sıkın insanlardan kurtulmamı sağlıyor.	Arkadaşımdan	118	2,72	1,212	,895	,372	Medya	62	2,55	1,250	Oyun oynamama yardımcı oluyor.	Arkadaşımdan	118	3,37	1,370	,823	,411	Medya	62	3,19	1,424																																																																																					
Ders bilgilerimi paylaşmamı sağlıyor.	Arkadaşımdan	118	3,13	1,291	,776	,439																																																																																																																																																																																																														
	Medya	62	2,97	1,342			Gün içinde zaman geçirmeme yardımcı oluyor.	Arkadaşımdan	118	3,84	,906	,825	,410	Medya	62	3,95	,798	Kendi video ve fotoğraflarımı insanlarla paylaşmak hoşuma gidiyor.	Arkadaşımdan	118	3,31	1,202	,007	,994	Medya	62	3,31	1,168	Yeni insanlarla tanışmamı sağlıyor.	Arkadaşımdan	118	3,41	1,262	,258	,797	Medya	62	3,35	1,319	Sıkıntılarımı unutturuyor.	Arkadaşımdan	118	2,82	1,252	,661	,510	Medya	62	2,95	1,247	Gündemdeki gelişmeleri arkadaşlarımla paylaşmama/tartışmama yardımcı oluyor.	Arkadaşımdan	118	3,95	1,036	,938	,349	Medya	62	4,10	,936	Arkadaşlarının fotoğraflarına bakmak ve onların değişimlerini görmek hoşuma gidiyor.	Arkadaşımdan	118	3,88	,944	-,695	,488	Medya	62	3,98	,932	Hoşça vakit geçiriyor.	Arkadaşımdan	118	3,64	,901	,214	,831	Medya	62	3,61	,981	Bir gruba aitmiş hissine kapılmamı sağlıyor	Arkadaşımdan	118	2,47	1,027	,054	,957	Medya	62	2,48	1,198	Beni sıkın insanlardan kurtulmamı sağlıyor.	Arkadaşımdan	118	2,72	1,212	,895	,372	Medya	62	2,55	1,250	Oyun oynamama yardımcı oluyor.	Arkadaşımdan	118	3,37	1,370	,823	,411	Medya	62	3,19	1,424																																																																																																
Gün içinde zaman geçirmeme yardımcı oluyor.	Arkadaşımdan	118	3,84	,906	,825	,410																																																																																																																																																																																																														
	Medya	62	3,95	,798			Kendi video ve fotoğraflarımı insanlarla paylaşmak hoşuma gidiyor.	Arkadaşımdan	118	3,31	1,202	,007	,994	Medya	62	3,31	1,168	Yeni insanlarla tanışmamı sağlıyor.	Arkadaşımdan	118	3,41	1,262	,258	,797	Medya	62	3,35	1,319	Sıkıntılarımı unutturuyor.	Arkadaşımdan	118	2,82	1,252	,661	,510	Medya	62	2,95	1,247	Gündemdeki gelişmeleri arkadaşlarımla paylaşmama/tartışmama yardımcı oluyor.	Arkadaşımdan	118	3,95	1,036	,938	,349	Medya	62	4,10	,936	Arkadaşlarının fotoğraflarına bakmak ve onların değişimlerini görmek hoşuma gidiyor.	Arkadaşımdan	118	3,88	,944	-,695	,488	Medya	62	3,98	,932	Hoşça vakit geçiriyor.	Arkadaşımdan	118	3,64	,901	,214	,831	Medya	62	3,61	,981	Bir gruba aitmiş hissine kapılmamı sağlıyor	Arkadaşımdan	118	2,47	1,027	,054	,957	Medya	62	2,48	1,198	Beni sıkın insanlardan kurtulmamı sağlıyor.	Arkadaşımdan	118	2,72	1,212	,895	,372	Medya	62	2,55	1,250	Oyun oynamama yardımcı oluyor.	Arkadaşımdan	118	3,37	1,370	,823	,411	Medya	62	3,19	1,424																																																																																																											
Kendi video ve fotoğraflarımı insanlarla paylaşmak hoşuma gidiyor.	Arkadaşımdan	118	3,31	1,202	,007	,994																																																																																																																																																																																																														
	Medya	62	3,31	1,168			Yeni insanlarla tanışmamı sağlıyor.	Arkadaşımdan	118	3,41	1,262	,258	,797	Medya	62	3,35	1,319	Sıkıntılarımı unutturuyor.	Arkadaşımdan	118	2,82	1,252	,661	,510	Medya	62	2,95	1,247	Gündemdeki gelişmeleri arkadaşlarımla paylaşmama/tartışmama yardımcı oluyor.	Arkadaşımdan	118	3,95	1,036	,938	,349	Medya	62	4,10	,936	Arkadaşlarının fotoğraflarına bakmak ve onların değişimlerini görmek hoşuma gidiyor.	Arkadaşımdan	118	3,88	,944	-,695	,488	Medya	62	3,98	,932	Hoşça vakit geçiriyor.	Arkadaşımdan	118	3,64	,901	,214	,831	Medya	62	3,61	,981	Bir gruba aitmiş hissine kapılmamı sağlıyor	Arkadaşımdan	118	2,47	1,027	,054	,957	Medya	62	2,48	1,198	Beni sıkın insanlardan kurtulmamı sağlıyor.	Arkadaşımdan	118	2,72	1,212	,895	,372	Medya	62	2,55	1,250	Oyun oynamama yardımcı oluyor.	Arkadaşımdan	118	3,37	1,370	,823	,411	Medya	62	3,19	1,424																																																																																																																						
Yeni insanlarla tanışmamı sağlıyor.	Arkadaşımdan	118	3,41	1,262	,258	,797																																																																																																																																																																																																														
	Medya	62	3,35	1,319			Sıkıntılarımı unutturuyor.	Arkadaşımdan	118	2,82	1,252	,661	,510	Medya	62	2,95	1,247	Gündemdeki gelişmeleri arkadaşlarımla paylaşmama/tartışmama yardımcı oluyor.	Arkadaşımdan	118	3,95	1,036	,938	,349	Medya	62	4,10	,936	Arkadaşlarının fotoğraflarına bakmak ve onların değişimlerini görmek hoşuma gidiyor.	Arkadaşımdan	118	3,88	,944	-,695	,488	Medya	62	3,98	,932	Hoşça vakit geçiriyor.	Arkadaşımdan	118	3,64	,901	,214	,831	Medya	62	3,61	,981	Bir gruba aitmiş hissine kapılmamı sağlıyor	Arkadaşımdan	118	2,47	1,027	,054	,957	Medya	62	2,48	1,198	Beni sıkın insanlardan kurtulmamı sağlıyor.	Arkadaşımdan	118	2,72	1,212	,895	,372	Medya	62	2,55	1,250	Oyun oynamama yardımcı oluyor.	Arkadaşımdan	118	3,37	1,370	,823	,411	Medya	62	3,19	1,424																																																																																																																																	
Sıkıntılarımı unutturuyor.	Arkadaşımdan	118	2,82	1,252	,661	,510																																																																																																																																																																																																														
	Medya	62	2,95	1,247			Gündemdeki gelişmeleri arkadaşlarımla paylaşmama/tartışmama yardımcı oluyor.	Arkadaşımdan	118	3,95	1,036	,938	,349	Medya	62	4,10	,936	Arkadaşlarının fotoğraflarına bakmak ve onların değişimlerini görmek hoşuma gidiyor.	Arkadaşımdan	118	3,88	,944	-,695	,488	Medya	62	3,98	,932	Hoşça vakit geçiriyor.	Arkadaşımdan	118	3,64	,901	,214	,831	Medya	62	3,61	,981	Bir gruba aitmiş hissine kapılmamı sağlıyor	Arkadaşımdan	118	2,47	1,027	,054	,957	Medya	62	2,48	1,198	Beni sıkın insanlardan kurtulmamı sağlıyor.	Arkadaşımdan	118	2,72	1,212	,895	,372	Medya	62	2,55	1,250	Oyun oynamama yardımcı oluyor.	Arkadaşımdan	118	3,37	1,370	,823	,411	Medya	62	3,19	1,424																																																																																																																																												
Gündemdeki gelişmeleri arkadaşlarımla paylaşmama/tartışmama yardımcı oluyor.	Arkadaşımdan	118	3,95	1,036	,938	,349																																																																																																																																																																																																														
	Medya	62	4,10	,936			Arkadaşlarının fotoğraflarına bakmak ve onların değişimlerini görmek hoşuma gidiyor.	Arkadaşımdan	118	3,88	,944	-,695	,488	Medya	62	3,98	,932	Hoşça vakit geçiriyor.	Arkadaşımdan	118	3,64	,901	,214	,831	Medya	62	3,61	,981	Bir gruba aitmiş hissine kapılmamı sağlıyor	Arkadaşımdan	118	2,47	1,027	,054	,957	Medya	62	2,48	1,198	Beni sıkın insanlardan kurtulmamı sağlıyor.	Arkadaşımdan	118	2,72	1,212	,895	,372	Medya	62	2,55	1,250	Oyun oynamama yardımcı oluyor.	Arkadaşımdan	118	3,37	1,370	,823	,411	Medya	62	3,19	1,424																																																																																																																																																							
Arkadaşlarının fotoğraflarına bakmak ve onların değişimlerini görmek hoşuma gidiyor.	Arkadaşımdan	118	3,88	,944	-,695	,488																																																																																																																																																																																																														
	Medya	62	3,98	,932			Hoşça vakit geçiriyor.	Arkadaşımdan	118	3,64	,901	,214	,831	Medya	62	3,61	,981	Bir gruba aitmiş hissine kapılmamı sağlıyor	Arkadaşımdan	118	2,47	1,027	,054	,957	Medya	62	2,48	1,198	Beni sıkın insanlardan kurtulmamı sağlıyor.	Arkadaşımdan	118	2,72	1,212	,895	,372	Medya	62	2,55	1,250	Oyun oynamama yardımcı oluyor.	Arkadaşımdan	118	3,37	1,370	,823	,411	Medya	62	3,19	1,424																																																																																																																																																																		
Hoşça vakit geçiriyor.	Arkadaşımdan	118	3,64	,901	,214	,831																																																																																																																																																																																																														
	Medya	62	3,61	,981			Bir gruba aitmiş hissine kapılmamı sağlıyor	Arkadaşımdan	118	2,47	1,027	,054	,957	Medya	62	2,48	1,198	Beni sıkın insanlardan kurtulmamı sağlıyor.	Arkadaşımdan	118	2,72	1,212	,895	,372	Medya	62	2,55	1,250	Oyun oynamama yardımcı oluyor.	Arkadaşımdan	118	3,37	1,370	,823	,411	Medya	62	3,19	1,424																																																																																																																																																																													
Bir gruba aitmiş hissine kapılmamı sağlıyor	Arkadaşımdan	118	2,47	1,027	,054	,957																																																																																																																																																																																																														
	Medya	62	2,48	1,198			Beni sıkın insanlardan kurtulmamı sağlıyor.	Arkadaşımdan	118	2,72	1,212	,895	,372	Medya	62	2,55	1,250	Oyun oynamama yardımcı oluyor.	Arkadaşımdan	118	3,37	1,370	,823	,411	Medya	62	3,19	1,424																																																																																																																																																																																								
Beni sıkın insanlardan kurtulmamı sağlıyor.	Arkadaşımdan	118	2,72	1,212	,895	,372																																																																																																																																																																																																														
	Medya	62	2,55	1,250			Oyun oynamama yardımcı oluyor.	Arkadaşımdan	118	3,37	1,370	,823	,411	Medya	62	3,19	1,424																																																																																																																																																																																																			
Oyun oynamama yardımcı oluyor.	Arkadaşımdan	118	3,37	1,370	,823	,411																																																																																																																																																																																																														
	Medya	62	3,19	1,424																																																																																																																																																																																																																

Tablo 12 incelendiğinde, Facebook algı ölçeği “Yaşadığım çevreyi, toplumu yansıtan bilgiler elde etmemi sağlıyor.” maddesinde Facebook'u ilk duydukları yere göre Facebook'a yönelik algılarında anlamlı farklılık

bulunmuştur. Anlamlı farklılık bulunan bu maddede arkadaşlarımdan seçeneği medyaya göre Facebook'a yönelik algıları daha yüksektir. Diğer 19 maddede ise öğrencilerin Facebook'u ilk duydukları yere göre Facebook algılarında anlamlı farklılık bulunmamıştır.

g) Üniversite gençlerinin Facebook'a üyelik süresine göre Facebook'a yönelik algıları

Üniversite öğrencilerinin Facebook'a yönelik algılarının Facebook'a üyelik süresi yönünden bir fark gösterip göstermediği t-testi kullanılarak incelenmiş ve sonuçlar Tablo 13'de gösterilmiştir.

Tablo 13: Facebook'a Üyelik Süresine Göre t-Testi Sonuçları

Ne kadar zamandır Facebook kullanıyorsunuz?	N	\bar{X}	S	t	p	
Eğlenceli içerikler sunuyor.	1-2 yıl	82	4,10	,795	,121	,904
	3 yıl ve üzeri	98	4,11	,823		
Eski arkadaşlarıma tekrar ulaşmamı sağlıyor.	1-2 yıl	82	4,39	,698	1,127	,261
	3 yıl ve üzeri	98	4,51	,721		
Yaşadığım çevreyi, toplumu yansıtan bilgiler elde etmemi sağlıyor.	1-2 yıl	82	3,68	,980	,818	,415
	3 yıl ve üzeri	98	3,80	,873		
Merakımı gideriyor.	1-2 yıl	82	3,60	1,076	,559	,577
	3 yıl ve üzeri	98	3,68	,991		
Kendimi ifade etmemi sağlıyor	1-2 yıl	82	2,78	1,277	3,261	,001
	3 yıl ve üzeri	98	3,36	1,096		
Bu tür siteleri kullanmak hoşuma gidiyor.	1-2 yıl	82	3,37	1,000	1,372	,172
	3 yıl ve üzeri	98	3,56	,909		
Boş zamanlarımı değerlendirmemi sağlıyor.	1-2 yıl	82	3,57	1,144	,752	,453
	3 yıl ve üzeri	98	3,69	1,009		
İnsanlar arasında daha kolay fark edilmeme/tanışmama imkân sağlıyor.	1-2 yıl	82	2,79	1,312	1,433	,154
	3 yıl ve üzeri	98	3,06	1,200		
Aile üyeleri ve arkadaşlarla bir arada olmamızı sağlıyor.	1-2 yıl	82	3,28	1,210	3,529	,001
	3 yıl ve üzeri	98	3,89	1,073		
Ders bilgilerimi paylaşmamı sağlıyor.	1-2 yıl	82	3,04	1,300	,334	,739
	3 yıl ve üzeri	98	3,10	1,320		
Gün içinde zaman geçirmeme yardımcı oluyor.	1-2 yıl	82	3,80	,922	1,029	,305
	3 yıl ve üzeri	98	3,94	,823		
Kendi video ve fotoğraflarımı insanlarla paylaşmak hoşuma gidiyor.	1-2 yıl	82	3,43	1,176	1,256	,211
	3 yıl ve üzeri	98	3,20	1,192		
Yeni insanlarla tanışmamı sağlıyor.	1-2 yıl	82	3,27	1,248	1,158	,248
	3 yıl ve üzeri	98	3,49	1,302		
Sıkıntılarımı unutturuyor.	1-2 yıl	82	2,82	1,239	,487	,627
	3 yıl ve üzeri	98	2,91	1,261		
Gündemdeki gelişmeleri arkadaşlarımla paylaşmama/tartışmama yardımcı oluyor.	1-2 yıl	82	4,07	,927	,895	,372
	3 yıl ve üzeri	98	3,94	1,063		
Arkadaşlarımla fotoğraflarına bakmak ve onların değişimlerini görmek hoşuma gidiyor.	1-2 yıl	82	4,01	,793	1,281	,202
	3 yıl ve üzeri	98	3,84	1,042		
Hoşça vakit geçiriyor.	1-2 yıl	82	3,48	1,033	2,064	,041
	3 yıl ve üzeri	98	3,77	,810		
Bir gruba aitmiş hissine kapılmamı sağlıyor	1-2 yıl	82	2,48	1,057	,024	,981
	3 yıl ve üzeri	98	2,48	1,114		
Beni sıkın insanlardan kurtulmamı sağlıyor.	1-2 yıl	82	2,46	1,113	2,025	,044
	3 yıl ve üzeri	98	2,83	1,293		

Oyun oynamama yardımcı oluyor.	1-2 yıl	82	3,27	1,406	,378	,706
	3 yıl ve üzeri	98	3,35	1,378		

Tablo 13 incelendiğinde, Facebook algı ölçeği “Kendimi ifade etmemi sağlıyor.”, “Aile üyeleri ve arkadaşlarla bir arada olmamızı sağlıyor.”, “Hoşça vakit geçiriyor.”, “Beni sıkın insanlardan kurtulmamı sağlıyor.” maddelerinde Facebook’u ne zamandır kullandıklarına göre Facebook’a yönelik algılarında anlamlı farklılık bulunmuştur. Anlamlı farklılık bulunan bu maddelerde 3 yıl ve üzeri 1-2 yıla göre Facebook’a yönelik algıları daha yüksektir. Diğer 16 maddede ise öğrencilerin Facebook’u ne zamandır kullandıklarına göre Facebook algılarında anlamlı farklılık bulunmamıştır.

h) Üniversite gençlerinin Facebook’a üyelik olma nedenlerine göre Facebook’a yönelik algıları

Üniversite öğrencilerinin Facebook’a yönelik algılarının Facebook’a üye olma nedenleri yönünden bir fark gösterip göstermediği varyans analizi (One-Way ANOVA) kullanılarak incelenmiş ve sonuçlar Tablo 14’de gösterilmiştir.

Tablo 14: Facebook'a Üyelik Olma Nedenlerine Göre Anova Sonuçları

Maddeler	Seçenekler	N	\bar{X}	Ss	F	P
Eğlenceli içerikler sunuyor.	Arkadaşlarım üye olduğu için	57	4,05	,875	1,863	,158
	Merakımı gidermek için	53	4,28	,769		
	Gündemde olduğu için	70	4,01	,771		
Eski arkadaşlarımla tekrar ulaşmamı sağlıyor.	Arkadaşlarım üye olduğu için	57	4,54	,657	,671	,513
	Merakımı gidermek için	53	4,40	,768		
	Gündemde olduğu için	70	4,43	,714		
Yaşadığım çevreyi, toplumu yansıtan bilgiler elde etmemi sağlıyor.	Arkadaşlarım üye olduğu için	57	3,89	,859	1,121	,328
	Merakımı gidermek için	53	3,66	,919		
	Gündemde olduğu için	70	3,69	,971		
Merakımı gideriyor.	Arkadaşlarım üye olduğu için	57	3,68	1,038	,869	,421
	Merakımı gidermek için	53	3,49	1,103		
	Gündemde olduğu için	70	3,73	,962		
Kendimi ifade etmemi sağlıyor.	Arkadaşlarım üye olduğu için	57	3,02	1,232	,868	,421
	Merakımı gidermek için	53	2,98	1,217		
	Gündemde olduğu için	70	3,24	1,197		
Bu tür siteleri kullanmak hoşuma gidiyor.	Arkadaşlarım üye olduğu için	57	3,35	1,061	1,576	,210
	Merakımı gidermek için	53	3,66	,854		
	Gündemde olduğu için	70	3,43	,926		
Boş zamanlarımı değerlendirmemi sağlıyor	Arkadaşlarım üye olduğu için	57	3,54	1,166	,439	,645
	Merakımı gidermek için	53	3,74	,984		
	Gündemde olduğu için	70	3,64	1,064		
İnsanlar arasında daha kolay fark edilmeme imkân sağlıyor.	Arkadaşlarım üye olduğu için	57	2,96	1,295	,291	,748
	Merakımı gidermek için	53	2,83	1,267		
	Gündemde olduğu için	70	3,00	1,228		
Aile üyeleri ve arkadaşlarla bir arada olmamızı sağlıyor.	Arkadaşlarım üye olduğu için	57	3,67	1,170	1,565	,212
	Merakımı gidermek için	53	3,38	1,147		
	Gündemde olduğu için	70	3,74	1,188		
Ders bilgilerimi paylaşmamı sağlıyor.	Arkadaşlarım üye olduğu için	57	3,21	1,292	2,832	,062
	Merakımı gidermek için	53	2,72	1,183		
	Gündemde olduğu için	70	3,23	1,374		
Gün içinde zaman geçirmeme yardımcı oluyor.	Arkadaşlarım üye olduğu için	57	3,96	,823	1,055	,350
	Merakımı gidermek için	53	3,74	,944		
	Gündemde olduğu için	70	3,91	,847		
Kendi fotoğraflarımı insanlarla paylaşmak hoşuma gidiyor.	Arkadaşlarım üye olduğu için	57	3,28	1,114	,288	,750
	Merakımı gidermek için	53	3,23	1,187		
	Gündemde olduğu için	70	3,39	1,254		
Yeni insanlarla tanışmamı sağlıyor.	Arkadaşlarım üye olduğu için	57	3,44	1,225	,193	,824
	Merakımı gidermek için	53	3,43	1,337		
	Gündemde olduğu için	70	3,31	1,291		
Sıkıntılarımla unutturuyor.	Arkadaşlarım üye olduğu için	57	3,44	1,225	,209	,812
	Merakımı gidermek için	53	3,43	1,337		
	Gündemde olduğu için	70	3,31	1,291		
Gündemdeki gelişmeleri arkadaşlarımla paylaşmama yardımcı oluyor.	Arkadaşlarım üye olduğu için	57	4,07	,904	,287	,751
	Merakımı gidermek için	53	3,92	1,124		
	Gündemde olduğu için	70	4,00	,993		
Arkadaşlarımın fotoğraflarına bakmak hoşuma gidiyor.	Arkadaşlarım üye olduğu için	57	3,77	1,018	,992	,373
	Merakımı gidermek için	53	3,98	,866		
	Gündemde olduğu için	70	3,99	,925		
Hoşça vakit geçiriyor.	Arkadaşlarım üye olduğu için	57	3,46	,927	1,556	,214
	Merakımı gidermek için	53	3,74	,984		
	Gündemde olduğu için	70	3,70	,874		
Bir gruba aitmiş hissine kapılmamı sağlıyor.	Arkadaşlarım üye olduğu için	57	2,68	1,105	1,778	,172
	Merakımı gidermek için	53	2,30	1,102		
	Gündemde olduğu için	70	2,44	1,044		
Beni sıkın insanlardan kurtulmamı sağlıyor.	Arkadaşlarım üye olduğu için	57	2,67	1,230	1,086	,340
	Merakımı gidermek için	53	2,47	1,137		
	Gündemde olduğu için	70	2,80	1,281		
Oyun oynamama yardımcı oluyor.	Arkadaşlarım üye olduğu için	57	3,28	1,373	,173	,841
	Merakımı gidermek için	53	3,25	1,413		
	Gündemde olduğu için	70	3,39	1,397		

Üniversite öğrencileri n Facebook'a yönelik algı anketinde üye olma nedenleri olarak sunulan "Arkadaşlarım üye olduğu için", "Merakımı gidermek için", "Gündemde olduğu için" seçenekleri ne verdikleri puanlar incelenmiştir. Tablo 14 incelendiğinde, öğrencilerin Facebook'a üye olma nedenlerine göre Facebook algı ölçeğindeki sorulardan elde ettiği ortalama puanlar arasında istatistiksel olarak anlamlı fark bulunamamıştır.

i) Üniversite gençlerinin interneti kullanma amaçlarına göre Facebook'a yönelik algıları

Üniversite öğrencilerinin Facebook'a yönelik algılarının interneti kullanma amaçları yönünden bir fark gösterip göstermediği varyans analizi (One-Way ANOVA) kullanılarak incelenmiştir.

Tablo 15: İnterneti Kullanma Amaçlarına Göre Anova Sonuçları

Maddeler	Seçenekler	N	\bar{X}	Ss	F	P
Eğlenceli içerikler sunuyor.	Haber takibi	28	4,14	,651	,652	,583
	Eğlence	68	4,15	,778		
	Araştırma yapmak	20	4,25	,910		
	E-maillerime bakmak	64	4,00	,873		
Eski arkadaşlarımla tekrar ulaşmamı sağlıyor.	Haber takibi	28	4,54	,693	,328	,805
	Eğlence	68	4,47	,585		
	Araştırma yapmak	20	4,50	,746		
	E-maillerime bakmak	64	4,39	,969		
Yaşadığım çevreyi, toplumu yansıtan bilgiler elde etmemi sağlıyor.	Haber takibi	28	3,82	,863	,430	,732
	Eğlence	68	3,65	1,004		
	Araştırma yapmak	20	3,75	,851		
	E-maillerime bakmak	64	3,81	,889		
Merakımı gideriyor.	Haber takibi	28	3,96	,881	1,125	,340
	Eğlence	68	3,62	1,051		
	Araştırma yapmak	20	3,60	1,046		
	E-maillerime bakmak	64	3,55	1,053		
Kendimi ifade etmemi sağlıyor.	Haber takibi	28	2,86	1,325	,826	,481
	Eğlence	68	3,25	1,189		
	Araştırma yapmak	20	2,95	1,146		
	E-maillerime bakmak	64	3,08	1,212		
Bu tür siteleri kullanmak hoşuma gidiyor.	Haber takibi	28	3,46	,962	1,201	,311
	Eğlence	68	3,66	,950		
	Araştırma yapmak	20	3,85	,988		
	E-maillerime bakmak	64	3,42	,940		
Boş zamanlarımı değerlendirmemi sağlıyor	Haber takibi	28	3,54	1,170	1,088	,355
	Eğlence	68	3,68	1,014		
	Araştırma yapmak	20	4,00	,562		
	E-maillerime bakmak	64	3,53	1,195		
İnsanlar arasında daha kolay fark edilmeme imkân sağlıyor.	Haber takibi	28	2,75	1,236	,834	,477
	Eğlence	68	3,12	1,264		
	Araştırma yapmak	20	2,95	1,317		
	E-maillerime bakmak	64	2,83	1,242		
Aile üyeleri ve arkadaşlarla bir arada olmamızı sağlıyor.	Haber takibi	28	3,71	1,150	,951	,417
	Eğlence	68	3,47	1,178		
	Araştırma yapmak	20	3,95	1,146		
	E-maillerime bakmak	64	3,61	1,190		
Ders bilgilerimi paylaşmamı sağlıyor.	Haber takibi	28	2,86	1,145	,513	,674
	Eğlence	68	3,21	1,299		
	Araştırma yapmak	20	3,00	1,338		
	E-maillerime bakmak	64	3,05	1,385		
Gün içinde zaman geçirmeme yardımcı oluyor.	Haber takibi	28	3,71	,854	,611	,609
	Eğlence	68	3,94	,912		
	Araştırma yapmak	20	4,00	,725		
	E-maillerime bakmak	64	3,84	,877		
Kendi fotoğraflarımı insanlarla paylaşmak hoşuma gidiyor.	Haber takibi	28	3,29	1,117	,844	,471
	Eğlence	68	3,21	1,241		
	Araştırma yapmak	20	3,39	1,119		
	E-maillerime bakmak	64	3,48	1,182		
Yeni insanlarla tanışmamı	Haber takibi	28	3,32	1,335	,160	,923

sağlıyor.	Eğlence	68	3,44	1,297		
	Araştırma yapmak	20	3,50	1,277		
	E-maillerime bakmak	64	3,33	1,261		
Sıkıntılarımı unutturuyor.	Haber takibi	28	2,82	1,249	,596	,619
	Eğlence	68	2,97	1,269		
	Araştırma yapmak	20	2,55	1,234		
	E-maillerime bakmak	64	2,88	1,241		
Gündemdeki gelişmeleri arkadaşlarımla paylaşmama yardımcı oluyor.	Haber takibi	28	4,11	,875	,850	,468
	Eğlence	68	3,97	1,036		
	Araştırma yapmak	20	3,70	1,218		
	E-maillerime bakmak	64	4,08	,948		
Arkadaşlarımla fotoğrafıma bakmak hoşuma gidiyor.	Haber takibi	28	3,86	,932	,288	,834
	Eğlence	68	3,96	,999		
	Araştırma yapmak	20	4,05	,999		
	E-maillerime bakmak	64	3,86	,870		
Hoşça vakit geçiriyor.	Haber takibi	28	3,57	,920	,066	,978
	Eğlence	68	3,66	,940		
	Araştırma yapmak	20	3,65	,875		
	E-maillerime bakmak	64	3,63	,951		
Bir gruba aitmiş hissine kapılmamı sağlıyor.	Haber takibi	28	2,29	1,150	,478	,698
	Eğlence	68	2,57	1,176		
	Araştırma yapmak	20	2,50	1,235		
	E-maillerime bakmak	64	2,45	,907		
Beni sıkın insanlardan kurtulmamı sağlıyor.	Haber takibi	28	2,46	1,201	,397	,755
	Eğlence	68	2,63	1,233		
	Araştırma yapmak	20	2,75	1,372		
	E-maillerime bakmak	64	2,75	1,195		
Oyun oynamama yardımcı oluyor.	Haber takibi	28	3,43	1,451	2,636	,051
	Eğlence	68	3,09	1,401		
	Araştırma yapmak	20	4,05	,887		
	E-maillerime bakmak	64	3,27	1,417		

Üniversite öğrencilerin Facebook’a yönelik algı anketinde interneti kullanma amaçları olarak sunulan “E-maillerime bakmak”, “Haber takibi”, “Eğlence”, “Araştırma yapmak” seçeneklerine verdikleri puanlar incelenmiştir. Tablo 15 incelendiğinde, öğrencilerin interneti kullanma amaçlarına göre Facebook algı ölçeğindeki sorulardan elde ettiği ortalama puanlar arasında istatistiksel olarak anlamlı fark bulunamamıştır.

TARTIŞMA ve SONUÇ

Bu çalışma kapsamında elde edilen veriler ışığında Facebook’un her geçen gün artan kullanıcı sayısı, sosyalleşme sürecinde internette en yaygın olarak tercih edilen sosyal paylaşım sitesi olduğunu kanıtlamaktadır. Bir diğer önemli olgu da, Facebook’un geliştirdiği yeni kullanım özellikleri ve paylaşım alanları ile kullanıcılarını ve kendi içerisinde geliştirdiği sosyalleşme sürecini sürekli olarak yeniden ürettiği gerçeğidir.

Sonuç olarak;

Küreselleşmenin hız kazanmasında önemli roller üstlenen iletişim teknolojilerinin aynı zamanda kültürel alanların da yeniden şekillenmesinde önemli işlevleri olmuştur. İletişimsel süreçler ve kültürel kimlikler, küreselleşmenin değerlerine göre yeniden yapılanmıştır. İnternetin yeni bir kültürel mekân, özgürlük alanı ve ekonomik bir pazar olarak ortaya çıkması, küresel formların, kültürel değerlerin, kimliklerin, alışkanlıkların hızlı bir şekilde dolaşıma sokulmasını sağlamıştır. İnternet kullanımında gelinen son nokta ise dünyadaki insan kümelerini bir ağ üzerinden birbirine bağlayan sosyal paylaşım siteleridir. Sosyal paylaşım siteleri normal bir iletişim alanı olmaktan öte kendine özgü kuralları olan, paylaşım alanı geniş bir sosyal olguya dönüşmektedir. Sosyal paylaşım sitelerinden en çok rağbet gören Facebook sınırsız, korunaklı, özgürlükler alanı ve hiyerarşinin olmadığı yenilikçi yapısıyla özellikle gençler için bir çekim merkezi haline gelmiştir. Kullanıcılar Facebook sayesinde kendilerini özgürce ifade etme ve toplumsal baskıdan uzak herhangi bir sorumluluk taşımak zorunda

olmadıkları yeni aidiyet alanları oluşturma imkânı bulurlar. Facebook, sanal ortamda kültürel bir mekân olarak kullanılmanın yanı sıra gençler için önemli bir toplumsal etkileşim alanı olduğu için de tercih edilmektedir.

Teknoloji ve bilgisayar kullanımına ilişkin herhangi bir engeli bulunmayan üniversite öğrencilerinin Facebook kullanma alışkanlıklarının belirlenmeye çalışıldığı bu araştırmada şu sonuçlar dikkat çekicidir.

Bireylerin Facebook kullanım alışkanlıklarının nedenleri:

- ✓ Bireylerin arkadaşları ile bağlantı kurabilmeleri, eski arkadaşlara ulaşmak istendiğinde yardımcı olması,
- ✓ Yeni arkadaşlıklar keşfetme olanağı sunması,
- ✓ İnsanların düşüncelerini paylaşmaları ve birbirleriyle kolayca etkileşime girmeleri,
- ✓ Kişisel bilgi ve fotoğraf içeren profil sayfası oluşturarak toplum tarafından fark edilme ihtiyacının karşılanması,
- ✓ Günlük yaşamın her alanının tartışmaya açılması ve neredeyse parodileştirilmesi ve tartışma konularındaki sınırsızlığa herkesin katkısının bulunabilmesi,
- ✓ Online olarak sağladığı ücretsiz ve eğlenceli oyunlarla oyun sevenleri memnun etmesi,
- ✓ Sınırsız video paylaşımına olanak sağlaması,
- ✓ Kullanıcıların fotoğraf albümleri paylaşmasını sağlayarak kişileri etkilemesi ve fotoğraflara yorum yapmaya açık olması,
- ✓ Her kullanıcının katkılarıyla gerçekleştirilen kolektif bir oluşum olması,
- ✓ Meraklarını, ortak profesyonel hedeflerini, dostluklarını paylaşabilmeleri,
- ✓ Mail ağı oluşturmaya yardımcı olması,
- ✓ Kişinin profilindeki arkadaşlarla (chat) sohbet edebilme imkânı sunması olarak sıralanabilir.

Araştırmada Facebook kullanımı belirli kriterlere göre değişiklik göstermekle birlikte genel olarak Facebook ile gündelik yaşam arasında birbiri içine geçmiş bir ilişkinin varlığı yadsınamaz bir durum haline geldiği gözlenmiştir.

ÖNERİLER

Bu çalışmada yoğun rağbet görmesiyle sosyal paylaşım ağlarına yeni bir biçim kazandıran Facebook'un, üniversite gençleri tarafından kullanılma nedenleri belirlenmeye çalışılmıştır. Çalışmanın devamı olarak, nicel araştırma ve nitel araştırma paradigmaları birleştirilerek her bir amaç doğrultusunda anketin yanı sıra her bir öğrenci ile görüşme yapılarak katılımcılardan derinlemesine bilgi toplanabilir. Ayrıca, farklı bir örnekleme grubu analiz edilerek karşılaştırma yapılabilir. Örneğin lise kademesinde ki gençler de ankete tabii tutularak, ortaya çıkan sonuçlar karşılaştırılabilir.

Çalışma Sinop Üniversitesi öğrencileri ile sınırlı olduğundan diğer üniversite öğrenciler kapsam dışında bırakılmıştır. Araştırma her bölge için yapılabilir. Üniversite öğrencilerinin Facebook kullanım nedenlerinin bölgeler arasındaki farklılıkları kıyaslanabilir.

Facebook örneği üzerinden yapılan sosyal iletişim ağlarının kullanımına ilişkin bu çalışma diğer sosyal iletişim ağları (badoo, blogcu, dailymotion, twitter vb.) üzerinden de yapılabilir. Daha sonra bulgulara dayanarak sonuçlar arasında karşılaştırma yapılabilir.

KAYNAKÇA

- Arslan, M. (2006). Değişim Sürecinde Yeni Dindarlık Formları: "Yeni Çağ" İnanışları Örneği. Değerler Eğitimi Dergisi, C. IV, (sayı 11), 8-9.
- Altunay, C. M. (2010). Twitter: Gündelik yaşamın yeni rutini "Pıt Pıt Net". İletişim, 12, 31-56.
- Binark, M. (2009). Yeni Medya Dolayımı İletişim Ortamında Olanakların ve Ol(a)mayanların Fakında Olmalı. Evrensel Kültür, (216), 60-63.
- Boyd, D.M. and Ellison, N.B. (2007). Social Network Sites:Definition, History, and Scholarship. Journal of ComputerMediated Communication: Vol:13, No:1, pp.210-230.
- Bulut, S. (2009). Medyada Çokuluslu Şirket Egemenliğine Doğru Evrilme (1. Baskı). Ankara: Ütopya Yayınları..
- Castells, M. (2006). Kimliğin Gücü, Çev.: Kılıç E., İstanbul: Bilgi Üniversitesi Yayınları, 2006.
- Cemgil, C.(2003). İnternet Kafeler Oyun ve Cemaat. Cogito Dergisi. 35,177-179.
- Creswell, J. W. (2005). Educational Research: Planning, conducting and evaluating quantitative and qualitative research. New Jersey: Pearson Prentice Hall.
- Çoklar, A. N. (2010). Bilgi ve İletişim Teknolojileri Işığında Dönüşümler. Ankara: Nobel Yayınevi.
- Davutoğlu, A.(2004). Küresel Bunalım (6. Baskı). İstanbul: Küre Yayınları.
- Desenli, N. (2000). Üniversite Gençliğinin Dini Hayatı. Eğitim Yazıları Dergisi (sayı: 2) 24-25.
- Gemmill, E., and Peterson, M. (2006). Technology Use among College Students: Implications for Student Affairs Professionals. NASPA Journal, 43(2), 280-300.
- Golder S., Wilkinson D., Huberman B., (2007) Rhythms of Social Interaction :Massaging within a Massive Online Network.
- Gültekin, B. ve Köker, N. (2006). İnternetin Halkla İlişkilere Etkisi: Sanal Ortamlarda İnteraktif Halkla İlişkilerin Yeni Kuralları. Yeni İletişim Ortamları ve Etkileşim Uluslararası Konferansı Kitabı. 1-3 Kasım. İstanbul. 139-152.
- Güzel, M. (2006). Küreselleşme, İnternet ve Gençlik Kültürü. Küresel İletişim Dergisi, (sayı 1),13-14.
- Güzel, M. (2006). Kültürel Çalışmalar İçinde İnternet. Yüksek Lisans Tezi, Kocaeli Üniversitesi, Sosyal Bilimler Enstitüsü, Kocaeli.
- Held, D., McGrew, A., Goldblatt, D. and Perraton, J. (2000). Global Transformations: Politics, Economics and Culture. Oxford: Blackwell, 2.
- İnce, S.(2000). Küreselleşme Sürecinde Bilgi Toplumu ve Dijital Kentler: Avrupa Birliği Örneği, Doktora Tezi, Mimar Sinan Üniversitesi, Fen Bilimleri Enstitüsü.
- Jameson, F. (2008). Kültürel Dönemeç (1. Baskı). Çev.: İnal, K. Ankara: Dost Kitabevi.
- Kabilan, M. K., Ahmad N. and Abidin, M. J. Z. (2010). Facebook: An online environment for learning of English in institutions of higher education?. The Internet and Higher Education, 13, 4, 179 – 187.
- Kalafat, Ö. (2011). Sosyal Ağların Yükseköğretimde Kullanımı: Gümüşhane Üniversitesi Facebook Örneği. 5th International Computer & Instructional Technologies Symposium, 22-24 September 2011, Fırat University, Elazığ.

- Kaplan, A. M. and Haenlein M.(2010). Users of the world, unite! The challenges and opportunities of Social Media. Kelley School of Business, Indiana University, Paris, France.
- Karaca, M. (2007). Sosyolojik Bir Olgu Olarak İnternet Gençliği. Doktora Tezi, Fırat Üniversitesi, Sosyal Bilimler Enstitüsü, Elazığ.
- Karaçor, S.(2007). Reklam İletişimi, İnternet ve Gazete Reklamlarının Etkilerine Yönelik Bir Araştırma. Konya:Çizgi Kitabevi.
- Karasar, N. (2002). Bilimsel araştırma yöntemi. Ankara: Nobel Yayınları.
- Kayan, R. (2007). Vahyin Gölgesinde Kimlik İnşası. İstanbul: Çıra Yayınları.
- Kent, L.(2008). Critical Analysis of Blogging In Public Relations. Public Relations Review, 34,32-40.
- Kesal, E. (2010). Kişilik Kavramı, 0-6 Yaş Grubu Çocuklarda Kişiliğin Gelişimi ve Sorunları. www.ercankesal.com , ET:19.05.2010
- Kır, G. (2008). İnternet ve Genç Kimliği. Yüksek Lisans Tezi, Kocaeli Üniversitesi, Sosyal Bilimler Enstitüsü, Kocaeli.
- Kierkegaard, S. (2010). Twitter thou doeth? Computer Law and Security Review, 26(6), 577-594.
- Kobak, K. ve Biçer, S. (2008). Facebook Sosyal Paylaşım Sitesinin Kullanım Nedenleri. Anadolu Üniversitesi, Sosyal Bilimler Enstitüsü, Eskişehir.
- Koçoğlu, Z. (2009). Webloguse in EFL writingclass. Ankara University Journal of Faculty of Educational Sciences, 42 (1), 311-327.
- Lampe, C., Ellison, N. & Steinfield, C. (2006). A face(book) in the crowd: social searching vs. social browsing. Proceedings of the 20th Anniversary Conference on Computer Supported Cooperative Work, Banff, Alberta, Canada.
- McQuail, D. and Windahl, S. (2005). İletişim Modelleri (2. Baskı). Ankara: İmge Kitabevi.
- Mutlu, E. (2005). Globalleşme, Popüler Kültür ve Medya. Ankara: Ütopya Yayınları.
- Nacht, R. ve P. Chaney (2007), Realty Blogging: Build Your Brandand Outsmart Your Competition, New York: McGraw-HillCompany.
- Onat, H. (2010). Kimlik ve Kimlik-Teoloji İlişkisi. www.hasanonat.net , Erişim Tarihi:18.12.2010.
- Reid, J. (2011). “We don’t Twitter, we Facebook”: An alternative pedagogical space that enables critical practices in relation to writing. English Teaching: Practice and Critique, 10(1), 58-80.
- Sanders, C. E., Field, T. M., Diego, M., Kaplan, M. (2000). The relationship of Internet use to depression and social isolation among adolescents. Adolescence, 16, 97-115.
- Thoits, A. - Virshup, K. (1997). Me's and We's: Forms and Functions of Social Identities. Edited by Richard D. Ashmore Lee Jussim, New York: Oxford University Pres.
- Timisi, N. (2003). Yeni İletişim Teknolojileri ve Demokrasi. Ankara: Dost Yayınevi.
- Turan, Z.(2011). Çevrimiçi Sosyal Ağlar: Öğrenciler Neden Facebook Kullanmıyor? 5th International Computer & Instructional Technologies Symposium, 22-24 September 2011, Fırat University, Elazığ.
- Ünal, S. (2007). Ötekinin Aynasındaki Yüzler. İstanbul: Doğu Kütüphanesi Yayınları, 12-17.
- Yazıcı, E. (2001). Üniversite Gençliği 2001 Araştırması. Ankara: Gazi Üniversitesi Yayınları.

Wang, S. S., Moon, S., Kwon, K. H., Evans, C. A. and Stefanone, M. A. (2010). Face off: Implications of visual cues on initiating friendship on facebook. *Computers in Human Behaviour*, 26(2), 226-234.

EK-1. Facebook Algı Ölçeđi

MADDELER		Kesinlikle Katılıyor	Katılıyor	Kararsız	Katılmıyor	Kesinlikle Katılmıyor
1	Eđlenceli içerikler sunuyor.					
2	Eski arkadaşlarıma tekrar ulaşmamı sağlıyor.					
3	Yaşadığım çevreyi, toplumu yansıtan bilgiler elde etmemi sağlıyor.					
4	Merakımı gideriyor.					
5	Kendimi ifade etmemi sağlıyor.					
6	Bu tür siteleri kullanmak hoşuma gidiyor.					
7	Boş zamanlarımı değerlendirmemi sağlıyor					
8	İnsanlar arasında daha kolay fark edilmeme/tanınmama imkân sağlıyor.					
9	Aile üyeleri ve arkadaşlarla bir arada olmamızı sağlıyor.					
10	Ders bilgilerimi paylaşmamı sağlıyor.					
11	Gün içinde zaman geçirmeme yardımcı oluyor.					
12	Kendi video ve fotoğraflarımı insanlarla paylaşmak hoşuma gidiyor.					
13	Yeni insanlarla tanışmamı sağlıyor.					
14	Sıkıntılarımı unutturuyor.					
15	Gündemdeki gelişmeleri arkadaşlarımla paylaşmama/tartışmama yardımcı oluyor.					
16	Arkadaşlarımla fotoğraflarına bakmak ve onların değişimlerini görmek hoşuma gidiyor.					
17	Hoşça vakit geçiriyor.					
18	Bir gruba aitmiş hissine kapılmamı sağlıyor.					
19	Beni sıkkan insanlardan kurtulmamı sağlıyor.					
20	Oyun oynamama yardımcı oluyor.					

21: Daha çok nereden internete bağlanıyorsunuz?

- Evden
 Diğer

22: İnterneti daha çok hangi amaçla kullanıyorsunuz?

- E-maillere bakmak için
 Haberleri takip etmek için
 Araştırma yapmak için
 Eğlence

23: Facebook' a neden üye oldunuz?

- Arkadaşlarım üye olduğu için
 Merakımı gidermek için
 Gündemde olduğu için

24: Facebook'u ilk nereden duydunuz?

- Arkadaşımdan
 Medya

25: Ne kadar zamandır facebook kullanıyorsunuz?

- 1-2 yıl
 3 yıl ve üzeri

26: Size göre internet ne derece güvenilir bir kitle iletişim aracıdır?

- Az
 Orta
 Güçlü

27: Yaşınız

28: Cinsiyetiniz

- Bayan
 Erkek

29: Yaşadığınız Yer

- Taşra
 Şehir

S30: Kimlerle Yaşıyorsunuz?

- Ailemle
 Arkadaşlarımla Birlikte

S31: Ailenizin Aylık Ortalama Geliri Nedir?

S32: Bölümünüz

EXAMINING THE ITEM-WORDING EFFECT ON THE SELF-REPORT SCALE

Kuan-Ming CHEN

Tsung-Hau JEN

In any assessment negatively phrased items are initially used as a strategy to disrupt acquiescence or affirmation bias, and supposedly measure the same construct as positively phrased items do. There are two perspectives when the responses to the negatively phrased items deviate from the responses to the positively phrased items in an assessment. The first explanation attributes the deviation to the method effect or response bias. For example, the negatively phrased items require respondents' cognitive ability to apply inverse reasoning (e.g. Marsh, 1986). The other supports that the negatively phrased items represent a construct different from the positively phrased items (e.g. Spencer-Rodgers, Peng, Wang, Hou, 2004). By analyzing the Taiwanese 4th-grade and 8th-grade students' responses to TIMSS 2011 questionnaires on positive attitude toward mathematics and self-confidence of learning mathematics, the present research suggests that the negative wording items represent a construct different from the one reflected by the positive wording items.

Keywords: item-wording effect, TIMSS, self-concept, self-confidence, self-attitude toward mathematics

MATEMATİK KAYGISI VE ENDİŞESİNİN CİNSİYET, SINIF DÜZEYİ VE OKUL TÜRÜ BAKIMINDAN İNCELENMESİ

THE ANALYSIS OF MATH ANXIETY AND APPREHENSION IN TERMS OF GENDER, CLASS LEVEL AND SCHOOL TYPE

Kübra YILDIRIM
Dokuz Eylül Üniversitesi
Kubra.yildirim.90@hotmail.com

Nurevşan AKDAĞ
Dokuz Eylül Üniversitesi
Lenrfsn_3525@hotmail.com

Engin OKTAY
Dokuz Eylül Üniversitesi
enginoktay2000@gmail.com

ÖZET: : Bu araştırmanın amacı; ortaöğretim öğrencilerinin matematik kaygısı ve endişesinin cinsiyet, sınıf düzeyi ve okul türü bakımından incelenmesidir. Araştırmada Ikegulu(1998) tarafından geliştirilen, Özdemir (2011) ve Gür (2011) tarafından geçerlik ve güvenilirlik çalışması yapılan Matematik Kaygısı ve Endişesi Ölçeği (MKEÖ) kullanılmıştır. Araştırmanın verisi İzmir ilindeki iki farklı okuldan toplam 256 öğrenciden toplanmıştır. Okullardan biri devlet okulu diğeri ise özel okuldur. Devlet okulundan 214 öğrenci, özel okuldan 42 öğrenci ile çalışılmıştır. Araştırmada ortaöğretim öğrencilerinin cinsiyet, sınıf düzeyi, okul türünün matematik kaygısına ve endişesine etkisi incelenmiştir. Elde edilen bulgular incelendiğinde cinsiyet açısından anlamlı bir fark bulunmazken sınıf düzeyi ve okul türü açısından anlamlı bir fark bulunmuştur.

Anahtar sözcükler: matematik kaygısı ve endişesi, ortaokul öğrencileri

ABSTRACT: With the increase in the importance of mathematical sciences today, studies on math anxiety and apprehension have also increased. The aim of this research is to analyze the math anxiety and apprehension of secondary school students on gender, class level and school type. In this study, Math Anxiety and Apphension Scale , which was developed by Ikegulu (1998) and tested for reliability and validity by Özdemir (2011) and Gür (2011), was used. The data have been collected from 256 students from two different schools in Izmir, Turkey. One of the schools is a public school, and the other is a private school. 214 students from the public school and 42 from the private school participated. While analyzing the data, T-test and the Analysis of Variance have been carried out. In this study, the effects of math anxiety on secondary school students in terms of gender, class level and school type have been analyzed. After the evaluation, no significant differences have been found regarding gender, whereas class level and school type affected the level of anxiety dramatically.

Key words: math anxiety and apprehension , secondary school students

ÜNİVERSİTE ÖĞRENCİLERİNİN MATEMATİĞİN TEMELLERİNE İLİŞKİN FELSEFİ GÖRÜŞLERİ

UNIVERSITY STUDENTS' PHILOSOPHICAL VIEWS ABOUT THE FOUNDATION OF MATHEMATICS

Esra YEMENLİ
Anadolu University
esra.yemenli@gmail.com

Pınar ANAPA SABAN
Eskişehir Osmangazi University
panapa@ogu.edu.tr

ÖZET: Bu araştırmanın amacı, üniversite öğrencilerinin matematiğin temellerine ilişkin felsefi görüşlerini belirlemektir. Araştırmanın çalışma grubu iki devlet üniversitesinin Fen-Edebiyat fakültelerinin Matematik bölümlerine ve Eğitim Fakültelerinin İlköğretim Matematik Öğretmenliği programlarına kayıtlı 486 öğrenci oluşturmuştur. Araştırmada yöntem olarak tarama modeli kullanılmıştır. Öğrencilerin görüşlerini belirlemek amacıyla araştırmacılar tarafından bir ölçek geliştirilmiştir. Ölçeğin kapsam ve yapı geçerliliği faktör analizi, güvenilirliği iç tutarlılık yöntemi ile sağlanmıştır. Araştırmanın verilerinin analizinde parametrik olmayan testler kullanılmıştır. Bu araştırmada, öğrencilerin farklı matematik felsefelerini benimsediği belirlenmiştir. Ayrıca, öğrencilerin felsefi görüşleri, cinsiyet ve akademik başarıya göre farklılık göstermezken, Matematik felsefesi ve matematik tarihi vb dersleri alma durumlarına ve öğrenim gördüğü fakültelere göre farklılık göstermiştir.

Anahtar sözcükler: Matematik felsefesi, matematiğin doğası, yarı-deneyselcilik, mutlakçılık.

ABSTRACT: The aim of this study is to determine the philosophical views of the university students. The research subjects consist of 486 students in the Mathematics Departments of Art&Science Faculty and Elementary School Mathematics Teacher programmes of Education Faculty in two State Universities. In this study, descriptive survey method is used as a research method. A scale is developed by the researchers in order to determine students' views. The validity and reliability of the scale are provided by factor analysis and internal consistency, respectively. Non-parametric tests are used at the data analysis stage. In the result of study, it is determined that students recognize different philosophies of mathematics. Also, there are not differences among the students' opinions about philosophy of mathematics in terms of gender and academic achievement whereas there are differences in terms of the faculties they were students.

Key words: Philosophy of mathematics, nature of mathematics, quasi-empiricism, absolutist.

BİREYSEL GELİŞİM DOSYASI, ÜSTBİLİŞSEL FARKINDALIK ve AKADEMİK BAŞARI ARASINDAKİ İLİŞKİNİN İNCELENMESİ

EXAMINING THE RELATIONSHIP BETWEEN PORTFOLIO, METACOGNITIVE AWARENESS AND ACADEMIC ACHIEVEMENT

Canan CENGİZ
Karadeniz Teknik Üniversitesi
canancengiz@ktu.edu.tr

Ayşegül ASLAN
Karadeniz Teknik Üniversitesi
aysgl.aslan@gmail.com

Faik Özgür KARATAŞ
Karadeniz Teknik Üniversitesi
fokaratas@ktu.edu.tr

ÖZET: Günümüzde ölçmenin öğretimin bir parçası olması gerektiği görüşü performansa dayalı ölçme araçlarının önem kazanmasına sebep olmuştur. Bu araçlardan biri bireysel gelişim dosyasıdır. Bireysel gelişim dosyaları, öğrencilere derin öğrenme ve kendilerini değerlendirme imkanı tanımaktadırlar. Bu çalışmanın amacı, bireysel gelişim dosyası hazırlamanın Fen Bilgisi öğretmenliği programında öğrenim görmekte olan öğrencilerin üstbilişsel farkındalık seviyeleri üzerindeki etkisini ve üstbilişsel farkındalık seviyeleri ile akademik başarıları arasındaki ilişkiyi belirlemektir. Bu amaçla öğrencilerden Genel Kimya Laboratuvarı-I dersi kapsamında bireysel gelişim dosyası hazırlamaları istenmiştir. Elde edilen bulgular, öğrencilerin üstbilişsel farkındalık seviyelerinde uygulama sonunda anlamlı bir gelişme meydana geldiğini göstermiştir. Öğrencilerin akademik başarıları ile üstbilişsel farkındalık seviyeleri arasında anlamlı bir ilişki tespit edilememiştir. Elde edilen bulgulara dayanarak araştırmacılar tarafından yorumlar yapılmıştır.

Anahtar sözcükler: portfolyo, üstbilişsel farkındalık, akademik başarı

ABSTRACT: Nowadays, the argument that assessment and evaluation should be a part of education has given the performance-based assessment tools prominence. One of these tools is portfolio. Portfolios provide students with the opportunity of deep learning and assessing themselves. The aim of this study is to determine the effectiveness of portfolios on meta-cognitive awareness level and the relationship between meta-cognitive awareness level and academic achievement of students' who are enrolled in a pre-service science teacher training program. For this purpose, students have been asked to prepare a portfolio within the General Chemistry Laboratory-I. The findings showed that significant improvement occurred in meta-cognitive awareness level of learners at the end of the application. There were no significant difference found between the academic success and the meta-cognitive awareness level of the students. Comments were made based on these findings.

Key words: portfolio, meta-cognitive awareness, academic achievement

GİRİŞ

Öğrencilerin çabalarını, gelişimini ve başarılarını, bir veya daha fazla alanda sergileyen, öğrenci çalışmalarının amaçlı koleksiyonuna bireysel gelişim dosyası denir (Paulson, Paulson & Meyer, 1991).

Bireysel gelişim dosyaları, ölçülecek hedefleri, hangi ürünlerin/çalışmaların hangi hedefler için hazırlandığını belirten açıklamaları, değerlendirme kriterlerini, öğrencinin, dosyada yer alan ürünün/çalışmanın onun öğrenim hedeflerine ulaştığını nasıl gösterdiği ile ilgili olarak yazdığı yansıtıcı yazıları (her bir ürün için), öğrencinin öz değerlendirmesini ve öğretmenin değerlendirmesini içermelidir (Bekiroğlu, 2004).

Bireysel gelişim dosyaları derin öğrenmenin gerçekleşmesinde etkili öğrenme araçlarıdır (Demirören, Koşan & Palaoğlu, 2009) ve öğrencilerin kendi kendilerini değerlendirmelerini ve kendileri hakkında bilgi edinmelerini

sağlar (Tezci & Demirli, 2004). Bu sebeple araştırmacılar bireysel gelişim dosyalarının öğrencilerin üstbilişsel gelişimlerinde de etkili olduğunu belirtmektedirler (Kovalchick, 1997; White, 2004; Bekiroğlu, 2004).

Herhangi bir şeyin farkında olma ve onu anlama biliş olarak adlandırılırken, herhangi bir şeyi öğrenme ve anlamının yanı sıra onu nasıl öğrendiğinin farkında olma ise üstbiliş olarak adlandırılır (Senemoğlu, 2012). Üstbiliş öğretimi ile bireylerin bilişsel süreçlerini denetleyebilmeleri ve daha nitelikli bir öğrenme için bu süreçleri yeniden düzenleyerek daha etkili kullanmalarının sağlanması hedeflenir (Özsoy, 2008). Metabilişsel farkındalık ise, bireyin kendi düşüncesine yönelik derinlemesine düşünebilme ve öğrenme güçlüklerinin üstesinden gelmede problem çözme becerilerini kullanabilme yeteneğidir (Joseph, 2010).

Alanyazın incelendiğinde bireysel gelişim dosyalarının önemini vurgulayan çokça çalışma olduğu görülmektedir (Birgin, 2003; Ediger, 1996; Gezer, 2012; Kan, 2007; Moya ve O'Malley, 1994; Owings ve Follo, 1992; Valencia, 1990). Portfolyoyu konu alan çalışmalar genellikle portfolyoların akademik başarı üzerindeki etkisini araştırmaktadır (Okçu, 2007; Sezgin, 2008). Üstbilişsel farkındalık üzerine yapılan çalışmalar da özellikle son yıllarda artış göstermiştir. Bu çalışmalarda özellikle farklı öğrenim seviyesindeki öğrencilerin üstbilişsel farkındalık seviyeleri araştırılmakta veya üstbilişsel farkındalık seviyeleri farklı değişkenler açısından incelenmektedir (Memiş & Arican, 2013; Özsoy, Günindi, 2011; Yavuz & Memiş, 2010; Kiremitçi, 2013; Küçük, Cansız, Akgün, & İşleyen, 2014). Bununla birlikte çeşitli yaklaşım veya modellerin üstbilişsel farkındalık üzerine etkisinin incelendiği çalışmalar da mevcuttur. Örneğin Yurdakul & Demirel (2011) çalışmalarında yapılandırmacı öğrenme yaklaşımının üstbilişsel farkındalık üzerine etkisini araştırmışken, Feyzioğlu, & Ergin, Ö. (2012) ise 5E öğrenme modelinin üstbilişsel farkındalık üzerine etkisini araştırmışlardır. Kim (2005) ise yansıtıcı öğrenme aracının üstbilişsel farkındalık üzerine etkisini araştırmıştır. Portfolyoların üstbilişsel farkındalık üzerine etkisini araştıran çalışmalara ise literatürde az rastlanmaktadır (Meyer, Abrami, Wade, Aslan & Deault, 2010). Yine üstbilişsel farkındalık ve akademik başarı arasındaki ilişkiyi araştıran çalışmalara da alanyazında az rastlanmaktadır (Bağçeci, Döş, & Sarıca, 2013). Bu sebeple bu çalışmanın amacı bireysel gelişim dosyası hazırlamanın Fen Bilgisi öğretmenliği programında öğrenim görmekte olan öğretmen adaylarının üstbilişsel farkındalıkları üzerindeki etkisini ve üstbilişsel farkındalık seviyeleri ile akademik başarıları arasındaki ilişkiyi irdelemektir.

Bu çalışmada şu araştırma sorularına cevap bulunmaya çalışılmıştır:

- 1- Bireysel gelişim dosyası hazırlayan öğrencilerin üstbilişsel farkındalıklarında bir değişim olmuş mudur?
- 2- Üstbilişsel farkındalık seviyesi ile akademik başarı arasında bir ilişki var mıdır?

YÖNTEM

Çalışmanın amacına ulaşmak için nicel araştırma yöntemlerinden faydalanılmıştır. Çalışmanın ilk araştırma problemine cevap vermek amacıyla deneysel araştırma yöntemi kullanılmıştır. Deneysel çalışmalarda en azından bir bağımsız değişkenin, bir veya daha fazla bağımlı değişken üzerine etkisi incelenir (Fraenkel, Wallen & Hyun, 2012). Bu şekilde bireysel gelişim dosyası hazırlamanın üstbilişsel farkındalık üzerindeki etkisi incelenmiştir.

Çalışmanın ikinci araştırma problemine cevap vermek için ise korelasyonel araştırma deseni seçilmiştir. Korelasyonel araştırma, ilişkisel araştırmanın bir örneğidir. Bu tip araştırmalarda iki veya daha fazla değişken arasındaki ilişki araştırılır ve değişkenlere etki edilmez (Fraenkel, Wallen & Hyun, 2012). Bu sayede üstbilişsel farkındalık seviyesi ile akademik başarı arasındaki ilişkinin ortaya konulması amaçlanmıştır.

Örneklem

Çalışma fen bilgisi öğretmenliği programı birinci sınıfta öğrenim görmekte olan 35'i kız, 8'i erkek toplam 43 öğrenci ile gerçekleştirilmiştir.

Veri Toplama Araçları

Araştırma problemlerini irdelemek amacıyla üstbilişsel farkındalık envanteri ve başarı testi veri toplama araçları olarak işe koşulmuştur. Aşağıda bu veri toplama araçlarıyla ilgili detaylı bilgiler sunulmuştur.

Üstbilişsel Farkındalık Envanteri

Öğretmen adaylarının üstbilişsel farkındalıkları Schraw ve Dennison (1994) tarafından geliştirilmiş Bilişötesi Farkındalık Envanteri kullanılarak araştırılmıştır. Bilişötesi Farkındalık Envanteri 52 maddeden oluşmaktadır ve (1) Hiç bir zaman (2) Nadiren (3) Sık sık (4) Genellikle ve (5) Her zaman şeklinde 5'li Likert tipi bir derecelendirmeye sahiptir. Envanterin Türkçe formunun geçerlik ve güvenilirlik çalışması ise Akın, Abacı ve Çetin (2007) tarafından yapılmıştır. Envanterin iç tutarlılık ve test-tekrar test güvenilirlik katsayıları .95 olarak bulunmuştur. Üstbilişsel farkındalık envanteri uygulama başında ön test, uygulama sonunda son test olarak uygulanmış ve ön ve son uygulamalar arasındaki gelişimi görmek için bağımlı t testi uygulanmıştır.

Başarı Testi

Öğretmen adaylarının dersin amaçlarına yönelik başarıları ise bilgi, kavrama ve uygulama seviyesinde açık uçlu toplam 7 sorudan oluşan bir test ile belirlenmiştir. Test maddeleri araştırmacılardan biri tarafından geliştirilmiş aynı zamanda kapsam ve yapı geçerliliğinin artırılması amacıyla üç uzmana inceltirilmiştir. Öğrencilerin başarı testine verdikleri cevapları değerlendirmek amacıyla cevap anahtarı oluşturulmuştur. Her bir soru eşit olarak puanlandırılmıştır ve testten alınabilecek maksimum puan 98'dir. Öğrencilerin üstbilişsel farkındalık seviyeleri ile başarı testinden aldıkları puanlar arasındaki ilişkiyi araştırmak amacıyla pearson korelasyon katsayısına bakılmıştır.

Ortam ve Uygulama Süreci

Uygulama 2013-2014 güz yarıyılında, Genel Kimya Laboratuvarı-I Dersi kapsamında gerçekleştirilmiştir. Laboratuvar dersleri haftada bir gün, iki saattir. Genel Kimya Laboratuvarı I dersi kapsamında aşağıda konu başlıkları verilen toplam yedi deney gerçekleştirilmiştir: Alev testi, farklı sıcaklık ve kütledeki sıvıların karıştırılmasında ısı alışverişinin incelenmesi, konsantrasyonu bilinmeyen bir çözeltinin konsantrasyonunun tayini, çözeltilerin hazırlanması, asit, baz ve tuzların tanınması, naftalinin süblimleşmesi ve kristallendirme yöntemiyle saflaştırma.

Uygulama öncesinde öğrencilere üstbilişsel farkındalık envanteri ön test olarak uygulanmıştır. Uygulamanın ilk haftasında öğrencilere hazırlayacakları bireysel gelişim dosyaları hakkında bilgi verilmiş ve portfolyolarındaki ürünlerin nasıl değerlendirileceği açıklanmıştır. Öğrenciler yedi hafta boyunca portfolyo hazırlamışlardır. Öğrencilerden her deney öncesinde deneyle ilgili zihin haritası oluşturmaları (ilgili deneyin yapılacağı ders zihin haritaları kontrol edilmiştir), deneyden sonra ise arkadaşlarına deneyi anlatan bir mektup yazmaları ve son olarak da o hafta yapılan deney ile ilgili edindikleri kazanımlar ve oluşturdukları ürünler üzerine yansıtma yapmalarını sağlayacak yazılar yazmaları istenmiştir. Öğrencilerin arkadaşlarına yazdıkları mektuplar, arkadaşları tarafından, daha önceden araştırmacılarca hazırlanan rubrikler kullanılarak değerlendirilmiştir. Dersten önce hazırlanan zihin haritaları ve öğrencilerin bilgilerini ve ürünlerini değerlendirdikleri yansıtıcı yazılar ise çalışmayı yürüten araştırmacılar tarafından her hafta incelenmiş, geribildirim yazılarak, yine daha önceden araştırmacılar tarafından oluşturulmuş rubrikler kullanılarak puanlandırılmış ve öğrencilere teslim edilmiştir. Öğrencilerin hazırladığı bireysel gelişim dosyalarındaki ürünlerden aldıkları puanların ortalaması alınmış ve ikinci vize notu yerine sayılmıştır.

BULGULAR ve TARTIŞMA

Bu bölümde çalışmadan elde edilen bulgular iki başlık altında sunulmuştur. İlk bölümde öğrencilerin uygulama öncesi üstbilişsel farkındalık seviyeleri ile uygulama sonrası üstbilişsel farkındalık seviyeleri karşılaştırılmış ve elde edilen bulgular tartışılmıştır. İkinci bölümde ise öğrencilerin üstbilişsel farkındalıkları ve akademik başarıları arasındaki ilişki incelenmiş ve elde edilen bulgular tartışılmıştır.

Üstbilişsel Farkındalık Seviyesindeki Değişim

Bireysel gelişim dosyası uygulamasından önce ve sonra uygulanan üstbilişsel farkındalık envanterinden öğrencilerin aldığı puanların karşılaştırılması amacıyla bağımlı t testi uygulanmıştır. Elde edilen bulgular Tablo 1'de sunulmuştur. Tablo 1'de görüldüğü gibi öğretmen adaylarının uygulama sonunda üst bilişsel seviyelerinde bir artış görülmektedir. Yapılan t testi sonuçları uygulama öncesi ve uygulama sonrası üstbilişsel farkındalık envanterinden alınan puanlardaki bu artışın anlamlı olduğunu ortaya koymaktadır ($t=-3,213$; $p<0,05$).

Tablo 1. Öğrencilerin Üstbilişsel Farkındalık Ölçeği Öntest-Sontest Puanlarına Yönelik t-Testi Sonuçları

Testler	N	X	S	sd	t	p
Öntest	43	192,60	18,20	22,18	-3,705	,001
Sontest	43	205,14	22,18			

Bu analizlerden yola çıkılarak alanyazında belirtildiği gibi bireysel gelişim dosyaları hazırlamanın öğretmen adaylarının üstbilişsel farkındalıkları üzerine pozitif bir etkisi olduğu söylenebilir (Kovalchick, 1997; White, 2004; Bekiroğlu, 2004). Meyer, Abrami, Wade, Aslan ve Deault (2010) tarafından yapılan benzer bir çalışmada araştırmacılar e-portfolyo hazırlamanın 4-6. sınıf öğrencilerinin üstbilişsel farkındalıkları üzerindeki etkisini araştırmışlardır. Çalışmanın sonuçları, bireysel gelişim dosyası hazırlamanın üstbilişsel farkındalık üzerinde pozitif yönde bir etkisi olduğunu göstermiştir. Bu yönüyle çalışma sonuçlarımızla benzerlik göstermektedir.

Üstbilişsel Farkındalık Seviyesi ile Akademik Başarı Arasındaki İlişki

Öğretmen adaylarının üstbilişsel farkındalık envanterinden aldıkları puanlar ile başarı testinden aldıkları puanlar arasındaki korelasyona bakılmıştır. Elde edilen bulgular öğretmen adaylarının üstbilişsel farkındalık seviyeleri ile Genel Kimya Laboratuvarı I dersindeki akademik başarıları arasında çok zayıf pozitif bir ilişki olmakla birlikte bu ilişkinin anlamlı olmadığını göstermektedir ($r=0,122$; $p>0,05$). Bunun sebebi, öğretmen adaylarının başarılarını belirlemek amacıyla ölçülen testte yer alan soruların bilgi, kavrama ve uygulama düzeyinde sorular içermesinden kaynaklanmış olabilir. Öğrencilerin daha üst düzey (analiz, sentez ve değerlendirme) seviyede sorular içeren bir testten alacakları puanlar ile üstbilişsel farkındalık seviyeleri arasında daha güçlü bir ilişki mevcut olabilir. Çünkü üstbilişin gelişimi, öğrencileri üst düzey bir bilişsel sürece ulaştırır (Victor, 2004). Bağçeci, Döş, & Sarıca (2013), çalışmalarında ilköğretim 7.sınıf öğrencilerinin üstbilişsel farkındalıkları ile Seviye Belirleme Sınavı (SBS) ve Yılsonu Başarı Puanları (YSBP) arasındaki ilişkiyi incelemişlerdir. Öğrencilerin üstbilişsel farkındalıkları ile SBS başarıları ve üstbilişsel farkındalıkları ile yılsonu başarı puanları arasında pozitif yönde anlamlı ilişki bulunmuştur.

Bu çalışmada akademik başarı ve üstbilişsel farkındalık arasında anlamlı bir ilişki tespit edilememiş olmasının sebebi ise öğrencilerin akademik başarı testinden aldıkları puanlardan kaynaklanmış olabilir. Tablo 2'de öğrencilerin başarı testinden aldıkları puanların betimsel analizinden elde edilen bulgular sunulmuştur. Görüldüğü gibi elde edilen puanların standart sapması 13,18 ve ranjı ise 57'dir. Standart sapmanın ve ranjın büyük çıkmış olması bu durumu açıklayabilir.

Tablo 2. Öğrencilerin Başarı Testinden Aldıkları Puanların Betimsel Analizinden Elde Edilen Veriler

Standart sapma	13,18
Ranj	57
Minimum	12
Maksimum	69

SONUÇ ve ÖNERİLER

Bu çalışmanın sonuçları bireysel gelişim dosyası hazırlamanın üstbilişsel farkındalığın gelişmesinde etkili olduğunu göstermektedir. Bu sebeple derslerde bireysel gelişim dosyası değerlendirme yöntemlerinden yararlanılması tavsiye edilmektedir.

Bununla birlikte bu çalışmada bireysel gelişim dosyalarındaki ürünler haftalık olarak hazırlanmıştır ve bu ürünler zihin haritaları, mektuplar ve yansıtıcı yazılardan oluşmaktadır. Farklı öğrenme araçlarının toplandığı bireysel gelişim dosyalarının öğrencilerin üstbilişsel gelişimleri üzerinde farklı etkiler yaratabileceği düşünülmektedir. Bu sebeple farklı çalışmalarda farklı öğrenme araçlarının toplandığı bireysel gelişim dosyalarının öğrencilerin üstbilişsel farkındalıkları üzerine etkisi araştırılabilir.

Bu çalışmada ayrıca öğrencilerin üstbilişsel farkındalık seviyeleri ile akademik başarıları arasında anlamlı bir ilişki olmadığı tespit edilmiştir. Bunun sebebi olarak öğrencilerin akademik başarılarının tespit edilmesinde kullanılan test maddelerinin üst düzey bilişsel sorulardan oluşmamış olması gösterilebilir. Bu sebeple farklı araştırmalarda, üstbilişsel farkındalık ile hangi farklı bilişsel düzeydeki öğrenmenin daha fazla ilişkili olduğunu ortaya koymak amacıyla çeşitli çalışmalar yürütülebilir. Bu amaçla Bloom taksonomisine göre farklı seviyelerde soru içeren testlerin öğrencilere uygulanması ile elde edilen puanların, öğrencilerin üstbilişsel farkındalık seviyeleri ile arasındaki ilişkinin araştırılması ve bunların karşılaştırılmasının etkili olabileceği araştırmacılar tarafından düşünülmektedir.

KAYNAKLAR

- Akın, A., Abacı, R., & Çetin, B. (2007). The validity and reliability of the Turkish version of the metacognitive awareness inventory. *Educational Sciences: Theory & Practice*, 7(2), 671-678.
- Bağçeci, B., Döş, B., & Sarıca, R. (2013). İlköğretim Öğrencilerinin Üstbilişsel Farkındalık Düzeyleri İle Akademik Başarısı Arasındaki İlişkinin İncelenmesi. *Mustafa Kemal Üniversitesi Sosyal Bilimler Enstitüsü Dergisi*, 8(16), 551-566.
- Birgin, O. (2003). Bilgisayar Destekli Bireysel Gelişim Dosyasının Uygulanabilirliğinin Araştırılması, Yüksek Lisans Tezi, Karadeniz Teknik Üniversitesi, Trabzon.
- Demirören, M., Koşan, A. M. A. ve Palaoğlu, Ö. (2009). Bir öğrenme ve değerlendirme yöntemi olarak "Portfolyo". *Ankara Üniversitesi Tıp Fakültesi Mecmuası*, 62(1), 19-24.
- Ediger, M. (1996). Portfolios, Pupils and the Teacher, *Education Quarterly*, 25,1, 45-55.
- Feyzioğlu, E. Y., & Ergin, Ö. (2012). 5e Öğrenme Modelinin Kullanıldığı Öğretimin Yedinci Sınıf Öğrencilerinin Üst Bilişlerine Etkisi. *Türk Fen Eğitimi Dergisi*, 9(3), 55-77.
- Fraenkel, J. R., Wallen, N. E. & Hyun, H. H. (2012). How to design and evaluate research in education (8th Edition). USA: McGraw-Hill.
- Gezer, A. (2012). Portfolyo Değerlendirme Yönteminin İlköğretim I. Basamak II. Devre Kullanma Düzeyinin Öğretmen, Veli, Öğrenci Görüşlerine Bağlı Olarak Değerlendirilmesi, Yüksek Lisans Tezi, Çanakkale Onsekiz Mart Üniversitesi, Çanakkale
- Joseph, N. (2010). Metacognition needed: Teaching middle and high school students to develop strategic learning skills. *New Educational Review*, 54(2), 99-103.
- Kan, A. (2007). Portfolyo Değerlendirme, *Hacettepe Üniversitesi Eğitim Fakültesi Dergisi*, 32, 133-144.
- Kim, Y. (2005). Cultivating Reflective Thinking Tool On Learners' Learning Performance And Metacognitive Awareness In The Context Of On-Line Learning. Unpublished Doctoral Dissertation, The Pennsylvania State University, United States.
- Kiremitçi, O. (2013). Beden Eğitimi Ve Spor Yüksekokulu Öğrencilerinin Üstbilişsel Farkındalık Düzeyleri Üzerine Bir İnceleme. *Pamukkale Journal of Sport Sciences*, 4(3), 29-40.
- Kovalchick, A. (1997). Technology portfolios as instructional strategy. *TechTrends*, 42(4), 31-36.
- Küçük, B., Cansız, Ş., Akgün, L., & İşleyen, T. (2014). Ortaöğretim Matematik Öğretmeni Adaylarının Üstbiliş Farkındalıklarının Bazı Değişkenler Açısından İncelenmesi. *Kastamonu Eğitim Dergisi*, 22(1), 305-320.
- Memiş, A., & Arıcan, H. (2013). Beşinci Sınıf Öğrencilerinin Matematiksel Üstbiliş Düzeylerinin Cinsiyet Ve Başarı Değişkenleri Açısından İncelenmesi. *Karaelmas Eğitim Bilimleri Dergisi*, 1(1), 76-93.
- Meyer, E., Abrami, P. C., Wade, A., Aslan, O., Deault, L. (2010). Improving literacy and metacognition with electronic portfolios: Teaching and learning with EPEARL, *Computers & Education*, 55, 84-91.
- Moya, Sharon S. ve O'Malley, J. Michael. (1994). A portfolio assessment model for ESL, *The Journal of Educational Issues of Language Minority Students*, 13(1), 13-36.
- Ogan Berkıroğlu, F. (2008). Performansa Dayalı Ölçümler: Teori ve Uygulama. *Türk Fen Eğitimi Dergisi*, 5(1), 113-131.
- Okçu, Y. (2007). Matematik Eğitiminde Portfolyo Değerlendirme, Yüksek Lisans Tezi, Balıkesir Üniversitesi, Balıkesir.
- Owings, C. A. ve Follo, E. (1992). Effect of portfolio assessment on students attitudes and goal setting abilities in mathematics. Michigan.
- Özsoy, G. (2008). Üstbiliş. *Türk Eğitim Bilimleri Dergisi*, 6(4), 713-740.
- Özsoy, G. & Günindi, Y. (2011). Prospective preschool teachers' metacognitive awareness. *Elementary Education Online*, 10(2), 430-440.
- Parker White, C. (2004). Student portfolios: An alternative way of encouraging and evaluating student learning. *New Directions for Teaching and Learning*, 2004(100), 37-42.
- Paulson, F. L., Paulson, P. R. & Meyer, C. A. (1991). What makes a portfolio a portfolio? *Educational Leadership*, 48, 60-63.
- Schraw, G., & Sperling-Dennison, R. (1994). Assessing metacognitive awareness. *Contemporary Educational Psychology*, 19, 460-470.
- Senemoğlu, N. (2012). Gelişim, öğrenme ve öğretim kuramdan uygulamaya (21. baskı). Ankara: Pegem A Yayıncılık.
- Sezgin, F. (2008). Proje Tabanlı Öğrenme ve Portfolyo Değerlendirmenin Öğrenci Başarısına ve Tutum Düzeylerine Etkisi, Zonguldak Karaelmas Üniversitesi, Zonguldak.
- Tezci, E. Ve Demirli, C. (2004, Eylül). Bir performans değerlendirme modeli: bireysel gelişim dosyası, XII. Ulusal Eğitim Bilimleri Kurultayı, İnönü Üniversitesi Eğitim Fakültesi, Malatya.
- Valencia, S. (1990). A portfolio approach to classroom assessment: The whys, whats and hows. *The Reading Teacher*, 43(4), 338-40.
- Victor, A. M. (2004). The effects of metacognitive instruction on the planning and academic achievement of first and second grade children. Unpublished doctoral dissertation, II Graduate College of the Illinois Institute of Technology, Chicago.

- Yavuz, D., & Memiř, A. (2010). Investigation of Self-Efficacy Perception And Metacognitive Awareness of Prospective Teachers. *Int. J. Res. Teach. Educ*,1(1), 12-27.
- Yurdakul, B., & Demirel, Ö. (2011). Yapılandırıcı Öğrenme Yaklaşımının Öğrenenlerin Üstbiliş Farkındalıklarına Katkısı, *Uluslararası Eğitim Programları Ve Öğretim Çalışmaları Dergisi* 1(1), 71-85.

THE INVESTIGATION OF CONTENT KNOWLEDGE OF PRESERVICE ELEMENTARY MATHEMATICS TEACHERS ABOUT PROBABILITY

Gamze KURT
Middle East Technical University
gkurt@metu.edu.tr

ABSTRACT: Change in the middle school curriculum in Turkey necessitates the study of examination of knowledge of preservice elementary mathematics teachers about these highlighted subjects, namely probability. So, this study is significant in the needs of the Turkish mathematics education literature as well as it contributes to the consequences of curriculum efforts. In order to possess an understanding of probability and statistics concepts for preservice mathematics teachers and develop a comprehension, they must have both conceptual and procedural knowledge (Hiebert & Lefevre, 1986), where it is the main concern of this study. While using an instrument which considers probability knowledge as described in those two types of knowledge, researcher aims to understand to what extent preservice teachers are capable of conceptual and procedural knowledge of probability and statistics teaching. This paper deals with a part of data collected for the dissertation of the researcher.

Key words: Probability, content knowledge, preservice mathematics teachers

INTRODUCTION

This study aims to investigate the knowledge which is held by preservice elementary mathematics teachers in probability subjects limited with the elementary mathematics school curriculum in Turkey.

In our revised curriculum, which started to be instructed in middle-level schools in Turkey in September, 2013, the density of probability was reduced compared to previous curriculum, and its instruction is placed into the 8th grade level only with a superficial understanding of probability, such as determining the probable cases of an event, determining the cases whose probabilities are more probable, less probable or equiprobable, understanding that the probability of an event is between 0 and 1, and that of certain and impossible events, and computing the probability of a basic event. These can be called as ‘basic concepts of probability’. Moore (1997, as cited in Biehler, Ben-Zvi, Bakker, & Makar, 2012) recommends some changes from the statistical point of view, in that of content (more key concepts, and data analysis, and less probability), pedagogy (fewer lectures, more active learning) and technology (for data analysis and simulations). So, the new curriculum could be identified a well-reflection of Moore’s recommendation that it enhances more statistics and less probability while leaving the deeper conceptual knowledge to the high-school level, as compared with previous curricula with an integration of use of technology where available for teachers.

What earlier studies showed that preservice mathematics teachers have a less comprehension of probability compared with the other learning areas of curriculum, that is, they found probability subjects difficult to teach especially because of their lack of content knowledge related with them (Quinn, 1997; Stohl, 2005). Contemporary efforts are addressing the same issue as well so that teacher education should be enhanced while giving an attention to probability teaching for mathematics teachers (Stohl, 2005; Jones & Thornton, 2005). Change in the middle school curriculum necessitates the study of examination of knowledge of preservice elementary mathematics teachers about the highlighted subject, namely probability. Whether preservice elementary teachers have both conceptual and procedural level of understanding of probability in order to teach it has been understood (Star, 2005). So, this study is significant in the above needs of the Turkish mathematics education literature as well as it contributes to the consequences of curriculum efforts and will be a light for future considerations of this issue.

The research questions in this study are as follows: (a) to what extent are preservice elementary mathematics teachers capable of conceptual and procedural knowledge of probability subjects held in elementary mathematics curriculum in Turkey? (b) what are the main strengths and weaknesses of preservice elementary mathematics teachers in probability subjects held in elementary mathematics curriculum?

REVIEW OF RELATED LITERATURE

Before analyzing the knowledge for probability, it can be interpreted under the framework of mathematical knowledge for teaching (Hill, Ball, & Schilling, 2008). What this framework summarized the mathematical knowledge for teaching as in the following and Groth (2012) developed the framework from a stochastic knowledge point of view.

The framework formed by Hill, et.al. (2008). has two main dimensions for mathematical knowledge for teaching: first, subject matter knowledge which includes common content knowledge (CCK), specialized content knowledge (SCK) and knowledge at the mathematical horizon (Hill, et al., 2008); second, pedagogical content knowledge which includes knowledge of content and students (KCS), knowledge of content and teaching (KCT) and knowledge of curriculum. From the statistics point of view, CCK is considered as computing and interpreting the most frequent measures of central tendency; SCK is considered as special for teaching as which is best for which statistics term; Horizon knowledge is considered as working on populations will eventually emerge the working on samples, for example. For the second dimension, KCS can help teachers to catch the common strategies which students use in developing students' statistical reasoning; KCT deals with the content-specific strategies like knowing how to explain arithmetic mean as a fair share or as a balance point; and knowledge of curriculum can help teachers about structural properties that a curriculum possess (Groth, 2012).

Therefore, Groth has developed a framework for combining above terminology and suggested the following framework:

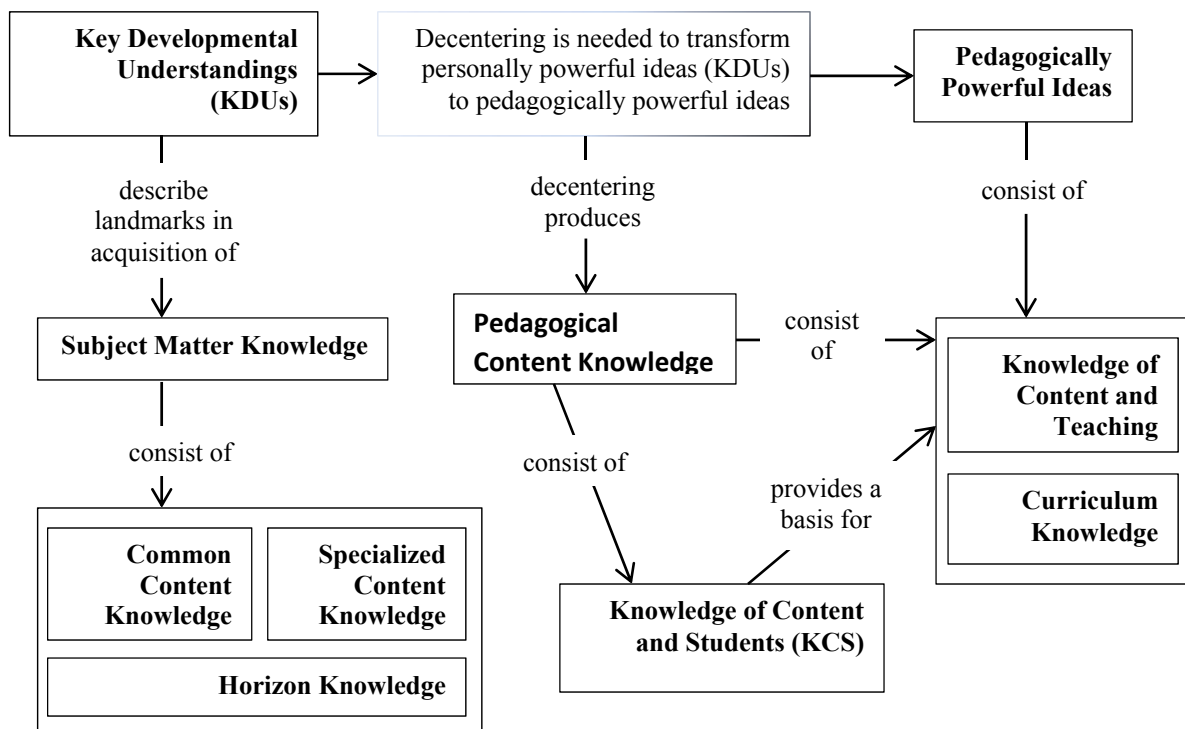

Figure1. Hypothesized SKT Framework Introduced by Groth (2013).

Based on the efforts in conducting the course which he was teaching, namely as Statistical Knowledge for Teaching (SKT) (including probability), he has developed the framework for SKT, while adding two new constructs to the statistical knowledge for teaching framework, one of which is key developmental understandings and the second one is pedagogically powerful ideas. Key developmental understandings were defined as “cognitive landmarks in the learning of fundamental ideas needed to understand content” (Simon, 2006, as cited in Groth, 2013). Pedagogically powerful ideas can be defined as ideas that occur as the result of transforming key developmental understandings into ideas that facilitate students’ learning of the key developmental understandings. Groth (2013) in his hypothesized framework relates these two dimensions with the other existing dimensions of mathematical knowledge of teaching.

Another dimension highlighted in this study is the conceptual and procedural knowledge types, which they introduced by first Scheffler (1965), but expanded by Hiebert and Lefevre (1986) and Star (2005), where 'procedural knowledge is characterized most clearly as knowledge that is rich in relationships, like a connected web of knowledge, a network in which the linking relationships are as prominent as the discrete pieces of information' (p. 3). They also categorize the conceptual knowledge as primary and reflective. Apart from conceptual knowledge Hiebert & Lefevre (1986) also explains the procedural knowledge in two types: 'one kind of procedural knowledge is a familiarity with the individual symbols of the system and with the syntactic conventions for acceptable configurations of symbols; the second kind of procedural knowledge consists of rules or procedures for solving mathematical problems' (p. 7). In order to possess an understanding of probability concepts for preservice elementary mathematics teachers and develop this comprehension, they must have both conceptual and procedural knowledge (Hiebert & Lefevre, 1986). Ball (1988) described the subject matter knowledge similar to above; she names the procedural knowledge as substantive knowledge, which refers to 'understanding of particular topics, procedures, concepts and relations among them' (p. 4), and secondarily, knowledge about mathematics is named in place of conceptual knowledge. So, this type of categorization fits with the above expressions, as well.

METHODOLOGY

This study uses qualitative efforts in order to investigate its research questions. Researcher plans to collect data through face-to-face interviews (later transcribed verbatim and analyzed through data coding with the usage of qualitative data analysis techniques as Creswell (2007) outlined in his book). Participants will be determined from elementary mathematics education departments where researcher can reach. The 3rd or 4th grade preservice teachers were chosen since the courses related with teaching methods related with subject matter knowledge have been covered beginning with the 3rd year of elementary mathematics teacher education in Turkey. Then, 23 participants have been interviewed voluntarily, who 12 of them are 4th year students and the rest are in their 3rd year of elementary mathematics teacher education. 9 of participants are from Istanbul University and 14 students are from Boğaziçi University.

In order to investigate the understanding of preservice elementary mathematics teachers' knowledge for probability, an instrument was used. It involves open-ended questions as well as multiple-choice items which deal with both the procedural and conceptual types of knowledge of probability. Specifically, it involves questions related to topics of probability of a basic event; certain, impossible and equally-likely events; theoretical and experimental probability. This instrument is organized with the questions taken Diagnostic Teacher Assessments in Mathematics and Science developed at the University of Louisville (CRiMSTeD-Center for research in Mathematics and Science Teacher Development). These assessments have established high levels of reliability and validity (Bush, et al, under review, as cited in Jacobbe, 2007). For this research, the questions, which are related with probability subjects framed by elementary mathematics curriculum in Turkey, were taken from CRiMSTeD. The items in this test are multiple-choice and open-ended questions and have been posed to the participants with a prepared sheet during interview. Besides, participants were also asked questions related with basic concepts in probability subjects covered in curriculum. The average duration for each interview was 45 minutes.

FINDINGS

During data collection period, participants were directed questions related with probability terminology such as the definition of probability, definitions of certain, impossible and equally likely events and calculation of probability of an event as well as they were asked to solve the test including 8 items related with the above subjects and additionally the difference/relation of theoretical and experimental probability. 5 of the items in the test are multiple-choice (choosing 1 among 4 alternatives) and the rest are open-ended questions.

During the interview, some of the participants defined probability as giving a method for calculation of it, it was not a complete definition, and some gave explanations with synonym words for probability. All of them knew that the measure of probability was between 0 and 1, which was another question directed through interview. They gave also complete explanations for certain and impossible events. For the definition of equally likely events, nearly half of the participants had a misconception that the probabilities of equally likely events are the same and $\frac{1}{2}$.

Related with the question how a probability of an event is calculated, most of the participants did not use the expected terminology, such as the word 'sample space'.

It is also worth to mention here that most of the participants have identified probability as the most troublesome topic for themselves, some were said that ‘I know probability, but I don’t know what I do in class while I am teaching it, since I don’t know the logic behind it’. Most of them have mentioned also that they found probability as the least known topic by themselves, and when the researcher asked the reason for that, probability was the topic which was accepted as dealing with abstract issues more with respect to other subjects in the elementary mathematics curriculum, according to responses of participants. They pointed that they learned probability without knowing in their elementary school years, like memorization. For this reason, nearly all of the participants considered the change in the curriculum related with the probability subject as meaningful and stressed that probability was early to teach in elementary school because of its abstract nature.

For the secondary data for this research, i.e. the test, evaluation of open-ended items was performed through a previously prepared rubric such that a full response means that participant talked about all the expected terminology and provided all the aspects of the topic covered in it; an incomplete response means that participant did not provide all of the expected discussion and did not a satisfactory response as much as expected; a wrong response means that participant responded irrelevantly and did not mention about any of the expected aspects of the topic covered in the item. The findings were summarized based on these data as in the following table:

Table 1. Findings Based on the Items

Item #	Type	Related Topic	Ratio of achievement
Item1	Multiple Choice	Impossible Event	22 of 23 are correct
Item2	Multiple Choice	Finding the probability of an event	23 of 23 are correct
Item3	Multiple Choice	Theoretical vs. Experimental Probability	17 of 23 are correct
Item4	Open-ended	Finding the probability of an event	6 of 23 responded full, 17 of 23 responded completely wrong.
Item5	Open-ended	Sample space	12 of 23 responded full, 4 of 23 responded wrong. 7 of 23 responded incomplete.
Item6	Open-ended	Theoretical vs. Experimental Probability	6 of 23 responded wrong or gave no information. 6 of 23 have responded incomplete. 11 of 23 responded full.
Item7	Multiple Choice	Types of events	17 of 23 are correct.
Item8	Multiple Choice	Sample space	20 of 23 are correct.

The items 1 and 2 were analyzing the procedural knowledge related with impossible events and finding the probability of an event. While all participants have responded correct to the second item, only one participant had a mistake in her response for the first item. Another item, which participants had higher achievement with respect to the others, was the last one, i.e. 20 participants responded correct to it. Fifth item which is related with the last have not been resulted with the similar findings as in the last one, although they cover the same topic. Nearly half of the participants (12 of 23) responded full, the rest answered incomplete or wrong to this item.

17 participants have responded correct to the third item, which is related with the relation of theoretical and experimental probability. Similar success ratio can be seen in the sixth item, which is related with the same subject. In the sixth item, participants were directed to describe a class activity showing the difference between theoretical and experimental probability. While 15 participants responded full, the rest gave incomplete or wrong answers. Some of them had no idea about the difference between theoretical and experimental probability, some were gave irrelevant examples.

Seventh item is another item which has a higher achievement ratio among all of the items, and it is questioning the types of events, like certain events, impossible events and equally likely events. 17 of participants have correctly answered to this question.

Fourth item was dealing with the predicting the catfish population in a river through two consecutive hunts, i.e. in the first hunt biologists caught 138 catfish and they marked them and in the second one, they caught 241 catfish, 16 of them are pre-marked. The condition is that 138 marked catfish intermingled freely in the river with the unmarked ones, and during the period between these two hunts, neither new catfish added nor existing catfish died. This item was the most challenging one in the test, although the related multiple-choice item had a higher achievement, most of the participants (17 of 23) answered completely wrong, only 6 of them gave a full response. There was no incomplete response for this item.

DISCUSSION

The findings of this study show similar aspects mentioned in the above framework for content knowledge described by Groth (2013), Hiebert & Lefevre (1986) and Ball (1988). According to their categorization of content knowledge, three of the items directed as open-ended all in the test can be described as dealing with conceptual knowledge and the rest are dealing with the procedural knowledge and all of them are multiple-choice items. It can also be said that the questions directed to participants during the interview, they could not show their conceptual knowledge about probability since their answers were mostly procedural knowledge base.

In general, it can be claimed that preservice elementary mathematics teachers has a high achievement in procedural level of knowledge for probability subjects limited in Turkish national elementary mathematics curriculum. They mostly know that the concepts, such as definition of probability, types of events, difference/relation between theoretical and experimental probability, definition of sample space. However, most of the participants have difficulty in answering the questions necessitating conceptual knowledge, which are related with the subjects of finding the probability of an event (catfish problem), sample space, and theoretical and experimental probability relationship. It can be claimed that the participants for this study have not an ability to connect what they know about probability and have not a higher-order comprehension needed for knowledge answering to the questions (Ball, 1988; Hiebert & Lefevre, 1986, Groth, 2013).

Based on the findings through interviews, definition of the probability of an event was performed procedurally, most of them used the sentence such as 'it means the division of wanted events divided by all events' although this definition has some terminological mistakes. For example, none of them used the word 'ratio' as defining it or the term 'sample space' as Green (1987) stated as one of the conditions of having an understanding of probability conceptually. For the definitions of certain and impossible events, all of them explained that a certain event has a probability of 1, and an impossible one has 0 as its probability. Some of them have provided examples for their definitions additionally and their examples were also appropriate. However, for the definition of equally likely events, nearly half of them explained that their probability is $\frac{1}{2}$ and they mostly supported their explanations with the example of coin tossing, like having a tail and having a head are equally likely events. This also shows that participants have not used the knowledge for probability as conceptually since they could not use the concept in different situations, they could not relate it with higher order thinking abilities (Ball, 1988).

Findings related with considering probability as one of the most abstract issues in mathematics shows that preservice teachers have an understanding of probability as a subject roughly, not deeply, which can also be claimed the reason is that their knowledge level is in the procedural level and lack of conceptual knowledge, they found probability as abstract.

The findings based on the test tend to be similar to the findings based on interview obviously since their achievement ratios to the items regarding the type of items as conceptual or procedural knowledge for probability. There were 3 paired (one for procedural and one for conceptual) items for three subjects: sample space, finding the probability of an event and difference/relation between theoretical and experimental probability. When these pairs compared with each other, it can be seen that achievement ratio of items for procedural knowledge are higher than their pairs for conceptual knowledge.

For example, third item prepared for difference/relation between theoretical and experimental probability is asking the true alternative based on the results of an experiment, in which colored spinner is used. Using an elimination method among the alternatives, 17 of participants made correct decision on this item. However, its paired item related with the same subject was searching for a class activity which can help to the students in order to distinguish the relation between theoretical and experimental probability. Most of the participants had difficulty in describing an activity which includes specifically increasing the number of experiment. The participants responded wrong to this item, had no idea about the difference about them. Therefore, it can again be claimed that preservice elementary mathematics teachers lack of conceptual thinking, they prefer to solve procedurally, not deepening their comprehension process (Ball, 1988; Hiebert & Lefevre, 1986).

When we consider the possible reasons of why conceptual knowledge of preservice elementary mathematics teachers have been less-developed compared with procedural knowledge, the courses offered for teacher candidates during their university education are like 'recipe-type' or 'rule-bound' courses which only deals with the calculations and lead preservice teachers to memorize the subjects while underestimating the logic behind it, as Shaughnessy (1992) stressed out previously (p.466). He claims also that preservice teachers lack of opportunity to develop their stochastic reasoning in university courses with their misunderstandings about probability. Nearly half of the participants have stressed that they feel themselves not knowing very well about probability although they have taken a course namely as probability and statistics. The other half of the students have mentioned that they have a course related with teaching probability and statistics in elementary level, however, unless they learned about probability very well, they cannot teach it so first they need to know it, as they expressed and therefore corresponds with the arguments by Shaughnessy (1992).

So on the whole, this study discussed the content knowledge for probability held by preservice elementary mathematics teachers very well. Findings implied that content knowledge assessed by the items in the test and questions directed through interviews have two dimensions, procedural and conceptual knowledge, as discussed clearly by the researchers previously (Hiebert & Lefevre, 1986; Ball, 1988; Groth; 2013) and corresponds to the framework which was bounded before.

RECOMMENDATIONS

The implications of this study will be enlightening for the future research of the content knowledge of preservice elementary mathematics teachers in Turkey. The discussion of the findings can have an impact on teacher education programs in the universities. While some universities have currently specific courses related with pedagogical content knowledge for statistics and probability (like Boğaziçi University) including content knowledge needed for those subjects as well, some of them have not. This study can have positive influences on the development of elementary mathematics education programs in nationwide, and might affect the perspectives of teacher educators, who are responsible for training the teachers, as well.

REFERENCES

- Ball, D. L. (1988). *The subject matter preparation of prospective mathematics teachers: Challenging the myths*. East Lansing, MI: National Center for Research on Teacher Education.
- Biehler, R., Ben-Zvi, D., Bakker, A., & Makar, K. (2012). Technology for enhancing statistical reasoning at the school level. In K. Clements, A. Bishop, C. Keitel, J. Kilpatrick, & F. Leung (Eds.), *Third international handbook of mathematics education*. New York: Springer.
- Bush, W. et. al. (under review). Diagnostic mathematics assessment for middle school teachers. *Journal of Mathematics Teacher Education*.
- Creswell, J. W. (2007). *Qualitative inquiry and research design: Choosing among five traditions* (2nd ed.). Thousand Oaks, CA: Sage.
- Green, D. (1987). Probability concepts: putting research into practice. *Teaching Statistics*, 9(1), 8-14.
- Groth, R. E. (2013). Characterizing key developmental understandings and pedagogically powerful ideas within a statistical knowledge for teaching framework. *Mathematical Thinking and Learning*, 15(2), 121-145.
- Groth, R. E. (2012). The role of writing prompts in a statistical knowledge for teaching course. *Mathematics Teacher Educator*, 1(1) 23–40. 2012

- Jacobbe, T. (2007). *Elementary school teachers' understanding of essential topics in statistics and the influence of assessment instruments and a reform curriculum upon their understanding* (Doctoral dissertation, Clemson University).
- Hiebert, J., & Lefevre, P. (1986). Conceptual and procedural knowledge in mathematics: An introductory analysis. In J. Hiebert (Ed.), *Conceptual and procedural knowledge: The case of mathematics* (pp. 1-27). Hillsdale, NJ: Erlbaum
- Hill, H. C., Ball, D. L., & Schilling, S. G. (2008). Unpacking pedagogical content knowledge: Conceptualizing and measuring teachers' topic-specific knowledge of students. *Journal for Research in Mathematics Education*, 372-400.
- Jones, G. A., & Thornton, C. A. (2005). An overview of research into the teaching and learning of probability. In *Exploring Probability in School* (pp. 65-92). Springer US.
- MONE (2013). *Ortaokul Matematik Dersi (5, 6, 7 ve 8. Sınıflar) Öğretim Programı (Middle-School Mathematics Curriculum (Grades 5, 6, 7 and 8))*. Ankara: MEB.
- Shaughnessy, J. M. (1992). Research in probability and statistics: Reflections and directions. In Grouws, D. A. (Ed) *Handbook of research on mathematics teaching and learning: A project of the National Council of Teachers of Mathematics*. (pp. 465-494). New York, NY, England: Macmillan Publishing Co. Inc.
- Star, J. R. (2005). Reconceptualizing procedural knowledge. *Journal for Research in Mathematics Education*, 36(5), 404-411.
- Stohl, H. (2005). Probability in teacher education and development. In *Exploring probability in school* (pp. 345-366). Springer US.
- Quinn, R. J. (1997). Effects of mathematics methods courses on the mathematical attitudes and content knowledge of preservice teachers. *The Journal of Educational Research*, 91(2), 108-114.

AN EFFECT OF HAVING INTERNET ACCESS ON PROSPECTIVE EARLY CHILDHOOD TEACHERS' INNOVATIVENESS PROFILES

Nursel YILMAZ

Middle East Technical University

Faculty of Education, Early Childhood Education

OYP (Faculty Development Programme) Research Assistant of Osmaniye Korkut Ata University

nyilmaz@metu.edu.tr

Refika OLGAN

Middle East Technical University

Faculty of Education, Early Childhood Education

rolgan@metu.edu.tr

ABSTRACT: Innovativeness is seen as the prior condition of the adoption and diffusion of the innovations (Rogers, 2003). Therefore, identifying individuals' innovativeness would be crucial in order to understand their tendency towards newness. Thus, this study aimed to investigate innovativeness profiles of pre-service early childhood teachers. Specifically, their level of innovativeness was examined within the four sub-dimensions namely, resistance to change, opinion-leading, openness to experience, and risk-taking. In addition, an effect of having Internet access on the sub-dimensions of innovativeness was explored as the second aim of this study. For this purpose, data were collected from 436 prospective early childhood teachers by using Turkish Individual Innovativeness Scale (TIS) (Kılıçer & Odabaşı, 2010). The gathered data were analyzed by conducting Multivariate Analysis of Variance (MANOVA). Based on the self-reported data, the results of the study indicated that pre-service early childhood teachers are open to experience and opinion leaders. On the other hand, they are neutral in risk-taking and resistance to change dimensions. Moreover, it was also found that having the Internet access has a statistically significant effect on the three sub-domains of innovativeness namely, resistance to change, opinion-leading, and openness to experience.

Keywords: diffusion of innovation, innovativeness, Internet, pre-service teachers, early childhood education

BİR DURUM ÇALIŞMASI: ORTAOKUL ÖĞRENCİLERİNİN ORANTISAL AKIL YÜRÜTME PROBLEMLERİNİ ÇÖZME SÜREÇLERİNİN, STRATEJİLER VE PROBLEM DEĞİŞKENLERİ AÇISINDAN İNCELENMESİ

A CASE STUDY: THE INVESTIGATION OF MIDDLE SCHOOL STUDENTS' PROPORTIONAL REASONING PROBLEM SOLVING PROCESSES IN TERMS OF STRATEGIES AND TASK VARIABLES

Emine ŞİMŞEK
Hacettepe Üniversitesi
eminesimsekbasaran@gmail.com

Zeynep SONAY AY
Hacettepe Üniversitesi
sonayp@gmail.com

Ali ŞİMŞEK
MEB
simsekali8701@gmail.com

ÖZET: Orantısal akıl yürütmenin cebirsel akıl yürütmeye, geometrik akıl yürütmeye ve matematiğin birçok konusuna temel oluşturduğu bilinmektedir. Alan yazın incelendiğinde öğrencilerde orantısal akıl yürütmenin varlığının ve orantısal akıl yürütme düzeylerinin tespit edildiği araştırmalara sıklıkla rastlanır. Ancak, öğrencilerin gelişim özelliklerine göre orantısal akıl yürütmenin değişimi ve gelişiminin incelendiği araştırmaların az sayıda olduğu görülür. Bu araştırma ile 9 ortaokul öğrencisinin toplamsal ve orantısal problemleri çözerken kullandıkları stratejiler ve problem değişkenlerinin kullanılan bu stratejiler üzerindeki etkisi araştırılmıştır. Araştırma nitel araştırma yöntemlerinden durum çalışması deseni ile yürütülmüştür. Çalışma grubunu Ankara İli Yenimahalle İlçesi' nde bir devlet ortaokulunda öğrenim gören farklı dokuz ortaokul öğrencisi (2' şer tane 5, 6, 7.sınıf, 3 tane 8.sınıf) oluşturmaktadır. Veriler klinik görüşme yoluyla toplanmıştır. Görüşmelerde kullanılan problemler için alan yazındaki farklı çalışmalardan (Lamon 1995; Modestou ve Gagatsis 2010; Fernandez, Llinears, Modestou ve Gagatis 2010) yararlanılmış, adaptasyon ve uyarılma çalışmaları yapılmıştır. Verilerin analizinde betimsel yaklaşımlardan yararlanılmıştır. Araştırma sonucunda sınıf düzeyi ilerledikçe, öğrencilerin orantısal ve toplamsal durumları ayırmakta daha başarılı olduğu; ancak öğrenilen içler-dışlar çarpımı algoritmasının toplamsal problemlere de genellendiği gözlenmiştir. Öğrencilerin çözüm için uyguladıkları strateji seçiminde en etkili faktör problemdeki nicelikler arasındaki oranın çeşidi (tam sayı/tam sayı olmayan oran) olmuş; ancak öğrencilerin problemin orantısal ya da toplamsal oluşunu ayırt etmeden çözüme ulaşmaya çalıştıkları görülmüştür. Öğrenciler problemde nicelikler arasında oran tam sayı ise, probleme orantısal, nicelikler arasındaki orantı tam sayı değil ise probleme toplamsal bir problemmiş gibi davranma eğilimindedirler. Bununla birlikte problemdeki niceliklerin doğasının (sürekli ya da kesikli olması) strateji seçimine etki etmediği görülmüştür. Bu bulgular ışığında okullarda öğrencilerin orantısal akıl yürütme becerilerini geliştirmelerine yardımcı olabilecek ortamların nasıl yapılandırılacağı tartışılacaktır.

Anahtar sözcükler: orantısal akıl yürütme, toplamsal ve orantısal stratejiler, problem değişkenleri

ABSTRACT: Proportional reasoning is known the basis of many topics and skills like trigonometry, algebraic reasoning, geometric reasoning etc.. Analyzing the literature, research that determine existence of proportional reasoning and the levels of proportional reasoning in students is quite common. However, there are few studies which investigate the change and development of proportional reasoning according to development of students. In this study, middle school students' strategies from 5th grade to 8th grade when solving proportional and additive problems and the effects of the problem variables on these strategies have been investigated. Its goal is to identify characteristics of the development of proportional reasoning and how the use of integer and non-integer ratios and the discrete or continuous nature of quantities influence this development. This research was one of the qualitative research methods and case study model was used in this study. The sampling of the research consisted of 9 students (2 5th grade students, 2 6th grade students, 2 7th grade students and 3 8th grade students) from an elementary school located in Yenimahalle, Ankara. Data were collected through clinical interviews. The data of the study was collected by the use of proportional and additional problems which was

developed in previous research (Lamon 1995; Modestou ve Gagatsis 2010; Fernandez, Llinear, Modestou ve Gagatis 2010). With comments of experts, problems were adapted to Turkish. Descriptive approach was utilized to analyze the data. Depending on grade level progress, students were observed to be more successful in separating the proportional and additive situations. However, it was observed that in grade 8 students focus on the application of the cross multiplication strategy even in additive problems. Because students (especially 8th grade students) failed to determine the additional nature of the task and therefore applied proportional strategies for its solution. Similarly, it was seemed that the opposite is also true for 5th-6th grade students. The most effective factor effected the selection of the strategies applied for the solution was the type of ratio (existence of an integer or a non-integer ratio) between quantities. Besides, the discrete or continuous nature of quantities does not seem to have an influence on the characteristics of the development of students' strategies from 5th to 8th grade. Based on these findings, the ways to help students develop proportional reasoning skills were discussed.

Key words: proportional reasoning, additive and proportional strategies, task variables

THE USE OF ADOBE CONNECT AND OPENMEETINGS IN DISTANCE EDUCATION

Mehmet BEŞKİRLİ
Selçuk Üniversitesi
mehmetbes@selcuk.edu.tr

Ahmet Oğuz AKTÜRK
Necmettin Erbakan Üniversitesi
aoakturk@konya.edu.tr

ABSTRACT: Education is a process aimed at changing behaviors in the way desired and planned. It is expected to see some changes at the end of the education process in the behaviors, qualities and knowledge of the persons. Some answers are sought for the question; how to give better education or instruction to keep these expectations up. As a result of the researches, there has appeared the concept of “education everywhere” (distance education) due to developments in new technological instruction techniques. Distance education is a platform where lessons are done in a total virtual world by videos, sounds in interactive way. There have been some drastic changes in education arena due to developments in mobile devices and internet. These technological developments changed the roles of teaching personnel and put them into mediator role of presenting meaning construction and interaction. In distance education, students and lecturers are not in the same place. However, teaching and learning process is better as the process is maintained online and interactive. At the end of this process, students are expected to be self-producing and self-managing persons. Integrating distance education into mobile devices does not only provide a way for unlimited access to required information but also makes distance education independent of time and place. There are several software products to form online classes in distance education. In this paper, strong and weak aspects of Adobe Connect and OpenMeetings software used for online classes in distance education will be examined together with their mobile uses.

Key words: Distance education, Mobile learning, Adobe Connect, OpenMeetings

INTRODUCTION

Education is a system that starts from beginning and continues to the end of the life. Today, the term education has been a necessity for all people without time and place limit. In other words, distance education has appeared due to necessity rather than an alternative to normal education. The persons lacking an opportunity of formal education meet their education needs through distance education (Beldarrain, 2006). That is one of the features of distance education. Distance education is not only associated with persons. It has been an alternative in some cases due to limitations of educational regulations and the difficulty of conducting in-class activities. Distance education is a planned education form in which there is no need for teachers and students to get together physically and they can conduct classes in internet atmosphere with the help of technology. Besides, there is a central student interaction in this education system.

Distance education activities can be enabled both synchronously and asynchronously (Snow, Pullen, & Mcandrews, 2005). In asynchronous distance education, students watch existing course videos at any time they like and there is not a simultaneous interaction between student and teacher. In synchronous distance education, students have courses by seeing and hearing the teacher at a planned time and there is a simultaneous interaction opportunity between them (Schullo, Hilbelink, Venable, & Barron, 2007). According to McVay Lynch (2002) synchronous learning atmosphere enables students’ motivation, instant interaction and feedback and personal improvement. Coghlan (2004) conveys that the majority of teachers and students tend to have an instant interaction. In time, the uses of synchronous tools have increased in web based training. Especially one of the online synchronous tools, the instant chatting app, has been used in many distance education studies (Cox, Carr, & Hall). It has been observed in a study about a course with synchronous chatting, students opt for communication via synchronous chatting apart from face to face communication and they are pleased with that method (Spencer & Hiltz, 2003). In distance education, attendants build learning communities by communicating via synchronous chatting to each other and they can easily convey their ideas (Duemer, Fontenot, Gumforty, Kallus, Larsen, Schafer, & Schaw 2002; Knupfer, Gram, & Larsen, 1997). In addition to web based synchronous chatting, web conference system (one of the new developments) is the newest computer based system that transmits video, picture and volume; enables sharing various applications, includes

whiteboard applications and transmits information synchronously (Knupfer, Gram, & Larsen, 1997). Synchronous distance education is not the same as conventional education, but it is the most similar to it through these systems. Teachers can conduct virtual courses and students can see one another and their teachers via that technology. Interaction is enabled and the presentation becomes better through the use of whiteboard and other visual factors (picture, video, etc.) (Palloff & Pratt, 1999). To conclude, synchronous distance education is becoming more popular today because it gives students and teachers the opportunity to have an instant interaction.

In distance education, instruction activities are handled through many different communication tools. However, some of these tools are no longer used with the impact of technology and computer and internet has become the most popular communication tools today. It is also observed that the mobile use of distance education has increased with the development of mobile tools. Distance education is always in a shift. Many changes have been made and still continue in distance education. Some of these changes are due to previous limited applications of distance education. Thus, the term *online synchronous distance education* which is the most modern now has appeared. A great number of education institutions worldwide began to conduct web based online synchronous courses (Gürol & Atıcı, 2001). Even in Turkey, many universities handle online courses for synchronous distance education with the help of various programs.

In Turkey, online synchronous distance education became more common with increase in the use of internet. According to Turkish Statistical Institute's data, the use of personal internet always increases. Persons have the opportunity to access online synchronous distance education with the help of that increase. In Diagram 1, we can see that the ration of domestic access to internet has increased as 16-74 year old persons use computer and internet in Turkey. In addition, according to data of Information and Communication Technologies Authority, use of internet via mobile devices in 2013 has increased about 23% compared to 2012. While 19.720.341 persons used internet via laptops and phones at the end of 2012, that number has reached 24.173.143 at the end of 2013 (BTK, 2012; TÜİK, 2013). That is a great progress. Now, there are 24 million probable users for mobile use of online distance education.

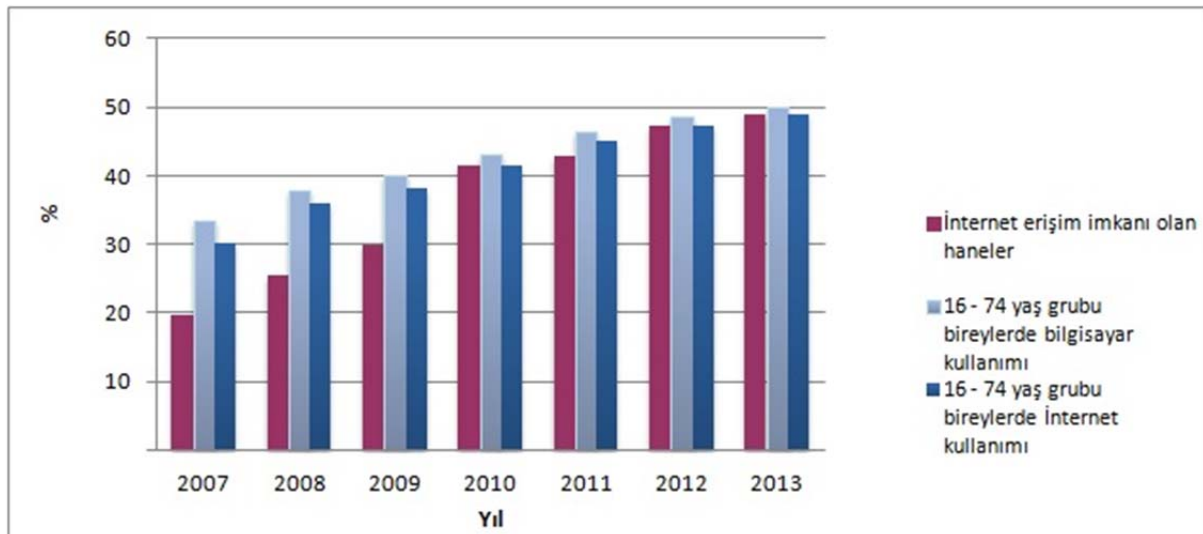

Diagram 1. Percentage of Houses with Access to Internet by Years

ADOBE CONNECT VE OPENMEETINGS

Adobe Connect and Openmeeting programs have common use aims such as distance education, teleconference, seminars and conferences with the help of volume and video. There are two ways to access to that use; first registered users, second guest users. Guest users can attend the meetings when the meeting host like.

Adobe Connect is a priced and licensed software that works through scanner and enables video conference in internet atmosphere. On the other hand, OpenMeetings works through scanner like Adobe Connect and enables video conference in internet atmosphere, but it is free and has a public code unlike Adobe Connect. These two softwares have the same goal but they work differently. We can see the general web interface outlook of OpenMeetings (Rayson & Aberdour, 2009) in Figure 1 and general web interface outlook of Adobe Connect in Figure 2.

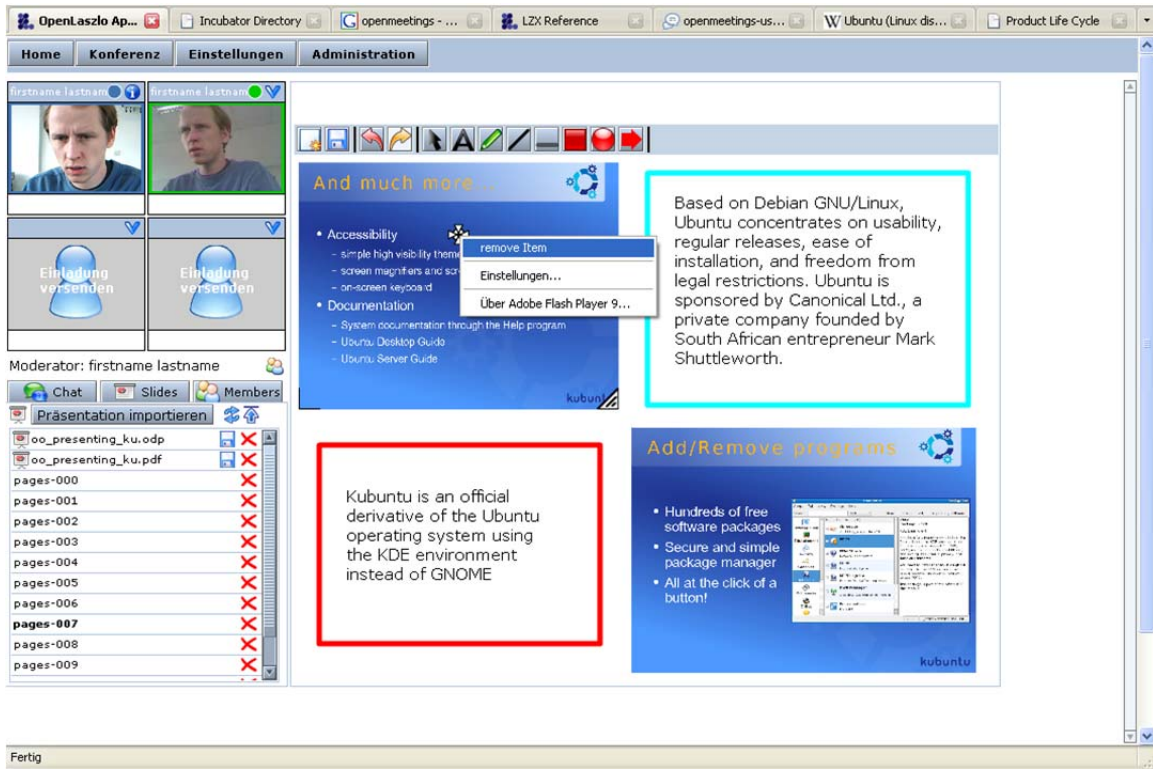

Figure 1. The General Web Interface Outlook of OpenMeetings

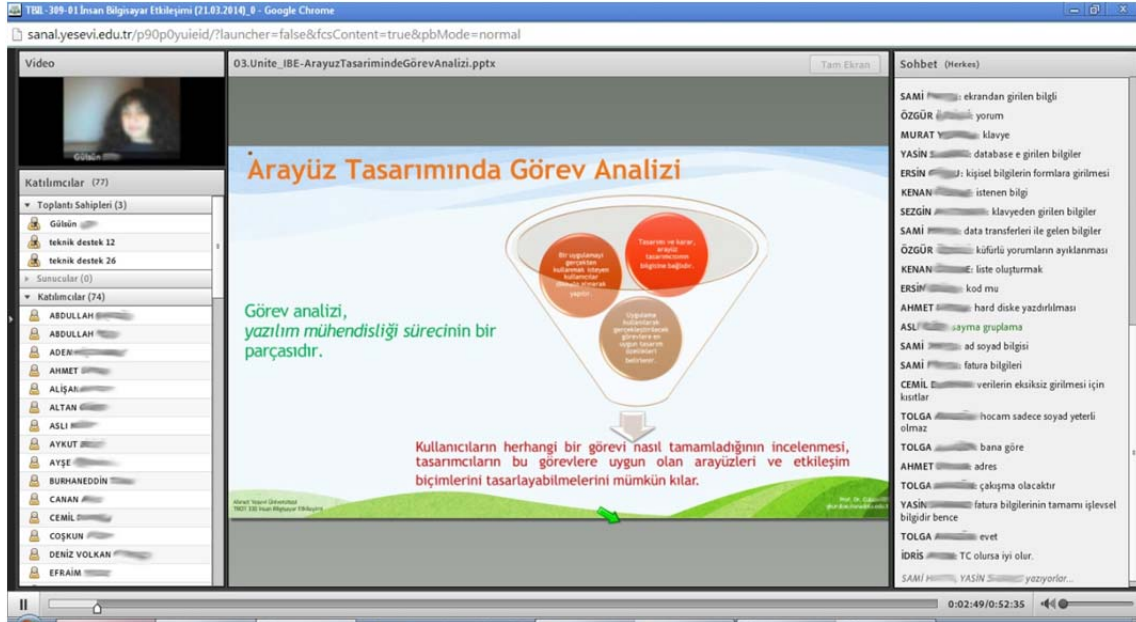

Figure 2. The General Web Interface Outlook of Adobe Connect

General Features of Adobe Connect and OpenMeetings

General features of two softwares and their pros and cons are stated below:

File Sharing

Both softwares permit file sharing. While Adobe Connect permits any file extensions, OpenMeetings permits such extensions as doc, .docx, .xls, .xlsx, .ppt, .pptx, .pdf, .jpg, .jpeg, .png, .gif, .txt, .psd, .bmp (Erturan, Çevik, Gürel, Çağiltay, 2012). Adobe Connect enables users to download any files that meeting host, or lecturer, upload.

Desktop Sharing

They both share desktop applications with users (students) by projecting desktop to the screen. Desktop sharing enables an interactive learning because any desktop application can be seen by every user at the same time. However, OpenMeetings has a limited screen sharing; it only enables full screen sharing. It is also possible to zoom during screen sharing in Adobe Connect. In addition, the meeting host has the possibility to interfere with users' desktop through share desktop; vice versa is also possible.

Whiteboard

Meeting host or permitted users can create text, line, square, circle and other drawings on this board simultaneously during the meeting. There are not many differences between Adobe Connect and OpenMeetings software in regard to whiteboard. Adobe Connect is more practical to use (Adobe, 2014; Şen, Atasoy, & Aydın, 2010).

Meeting Record

It is possible to save the meetings in Adobe Connect and OpenMeetings programs. Thus, especially students that missed the courses and the ones who want to watch the course again and again have the chance to watch any course they want from the archive. Users can only watch the missing courses but the meeting host has the opportunity to shorten the video durations if he/she wants. While both software are not too different on the subject of meeting record, in Adobe Connect, users can save the meeting to watch offline in addition to link in the course programs archive. The meeting host can send the meeting record to students via e-mail, in cd, dvd or floppy disc in FLV format, if he likes (Adobe, 2014).

Chatting

It is an interactive part in which attendants can ask and answer instant questions to the meeting host and one another during course. Both softwares have that feature but there are some differences, too. Meeting host or attendants can have instant chatting in Adobe Connect; in OpenMeetings, it is only possible to send private messages (Erturan et al., 2012; Adobe, 2014).

Here is a table about some features of Adobe Connect and OpenMeetings (Table 1) (Çınar, Tüzün, Yıldırım, Akıncı, Kalaycı, Bilgiç, & Yılmaz, 2011; Erturan et al., 2012; Wikipedia, 2014):

Table 1. Some Features of Adobe Connect and OpenMeetings

Product	Adobe Connect	OpenMeetings
Quality		
License	Licensed	Eclipse Public License
User Capacity (User Number)	1-1500	1-125
Operation System	Linux, Mac OS X, Microsoft Windows	Linux, Mac OS X, Microsoft Windows
Sound Support	Available	Available
Video Support	Available	Available
Video Quality	VGA, HQ, HD	VGA

Online Chat Support	Available	Available
Desktop Sharing Support	Available	Available
Document and Application Sharing	Available	Available (Limited)
Browser Sharing	Available	Available
Mobile Device Support	Available	Unavailable
Recording Capabilities	Available	Available
Break-Out Sessions	Available	Unavailable
Whiteboard Application	Available	Available
Encrypted Communication	Available	Available
Security Access	Available	Unavailable

Mobile Use

Mobile learning is an education system in which students learn as much as they need, whenever they need, and however they want; there is a learner based education, education progress is handled totally or partly via mobile technologies (Ozan, 2013; Odabaşı, 2009). Mobile learning has some advantages. It motivates learners to ask and answer questions by increasing their self-confidence. It makes learning more productive, effective and permanent by increasing cooperation among learners. It enables education anytime, anywhere, and in motion (Özdamar Keskin, 2011).

Mostly served online, distance education can be followed with privately developed applications for mobile devices via mobile phones, tablets and other mobile devices. You can attend online virtual courses from anywhere or watch them again and again with the help of mobile devices. Education continues anywhere without hesitation with mobile use (Chuang, 2009).

There is only Adobe Connect's application for mobile devices. Online synchronous distance education could easily be used even with EDGE connection in our previous trials (Figure 4). Mobile use is a little different from web based software. In figure 3, we can see an overlook of connecting to the meeting via mobile device. In figure 4, we see an online course sample in mobile device. In Figure 4, five visual menus, top and bottom, are available on the left side picture. In this menu; 1- There is a course platform. 2- There is full screen access to whiteboard. 3- Attendants of meeting can be seen. 4- Footage is transmitted full screen. 5- There is a chatting screen.



Figure 3. Connecting to Adobe Connect Meeting via mobile device

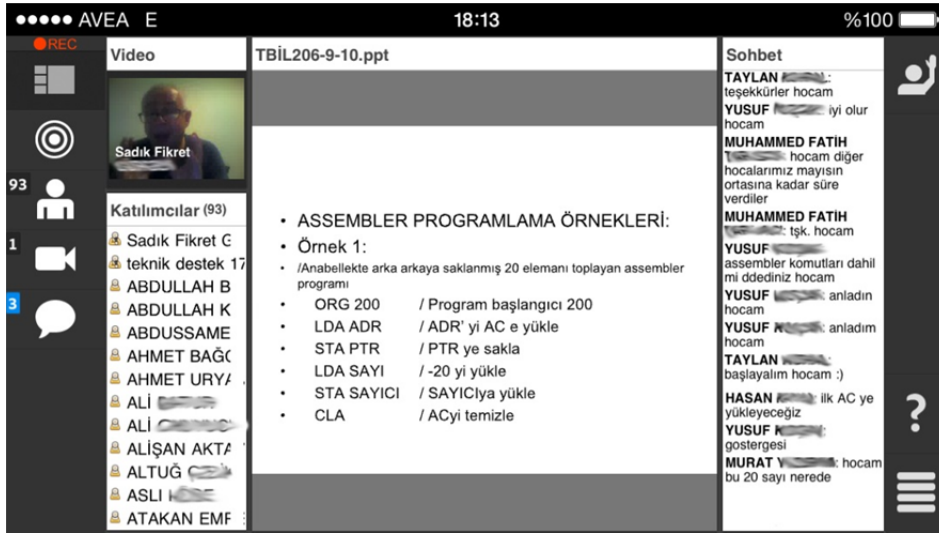

Figure 4. EDGE Connection to Meeting in Mobile Devices via Adobe Connect and General Outlook

CONCLUSION

Served on internet, distance education software has a great impact on education. Distance education software is an online and synchronous platform in which lecturer and students come together in an interactive atmosphere. With the help of these software, synchronous distance education contains all features of formal education in that it enables instant presentation sharing, use of whiteboard, chatting, the opportunity to attend with video and sound, file sharing (Ellingson & Notbohm, 2012; Işık, Karacı, Özkaraca, & Biroğlu, 2010).

Today, the use of mobile internet has increased with the increasing use of smart phones. Use of distance education as mobile has contributed to education at anytime and anywhere with the increase of mobile internet. It is also possible for users to have an interactive learning through the use of mobile distance education. It is possible to learn, without time and place limit, with access to distance education opportunities via mobile devices. Thus, access to information at any time is easier and it becomes permanent information because it is used immediately (Özdamar Keskin, 2011; Ozan, 2013).

Many software companies have prepared programs for synchronous distance education. Two of these softwares are searched in this study. Adobe Connect is thought to be more convenient in terms of distance education (Mavridis, Tsiatsos, & Tegos, 2011). It is thought that the mobile use of Adobe Connect has been more popular because of increasing mobile internet use.

SUGGESTIONS

Before using synchronous distance education software, no matter which one you use, a pilot study should be carried out. Possible problems should be solved; otherwise difficulties may alienate both meeting host and users from the system. As known, in addition to these two indicated programs, there are many virtual course applications and each one has different features. Firstly, we should choose a right program for desired education because our best choice may not be good for another organization. Thus, we should choose a program according to our target audience, technical infrastructure and needs (Schullo et al., 2007).

REFERENCES

- Adobe (2014). *ADOBE CONNECT 8'i Kullanma*, http://help.adobe.com/tr_TR/connect/8.0/using/connect_8_help.pdf, Erişim Tarihi: 04.04.2014.
- Beldarrain, Y. (2006). Distance education trends: Integrating new technologies to foster student interaction and collaboration. *Distance Education*, 27(2), 139-153, DOI:10.1080/01587910600789498
- BTK (Bilgi Teknolojileri ve İletişim Kurumu). (2012). *Türkiye'de internet ve mobil pazar istatistikleri*. http://btk.gov.tr/kutuphane_ve_veribankasi/raporlar/arastirma_raporlari/index.php, Erişim Tarihi: 28.04.2014.

- Chuang, K.-W. (2009). Mobile technologies enhance the e-learning opportunity, *American Journal of Business Education*, 2(9), 49-54.
- Coghlan, M. (2004). *How important are synchronous tools in web-based teaching and learning environments?* http://users.chariot.net.au/~michaelc/synch/surv_discuss.htm, Erişim Tarihi: 27.04.2014.
- Cox, G., Carr, T., & Hall, M. (2004). Evaluating the use of synchronous communication in two blended courses. *Journal of Computer Assisted Learning*, 20(3), 183-193, DOI:10.1111/j.1365-2729.2004.00084.x
- Çınar, M., Tüzün, H., Yıldırım, D., Akıncı, A., Kalaycı, E., Bilgiç, H. G., & Yılmaz, Y (2011). Uzaktan eğitimde kullanılan eşzamanlı sanal sınıf araçlarının karşılaştırılması, *XIII. Akademik Bilişim Konferansı, 2-4 Şubat 2012*, İnönü Üniversitesi, Malatya.
- Duemer, L., Fontenot, D., Gumforty, K., Kallus, M., Larsen, J., Schafer, S., & Schaw, B. C. (2002). The use of online synchronous discussion groups to enhance community formation and professional identity development, *The Journal of Interactive Online Learning*, 1(2), 1-12.
- Ellingson, D. A., & Notbohm, M. (2012). Synchronous distance education: Using web-conferencing in an MBA accounting course. *American Journal Of Business Education*, 5(5), 555-562.
- Erturan, Y. N., Çevik, R., Gürel, N.A., & Çağıltay, K. (2012). Eğitimde Webinar (Sanal Sınıf) kullanımı: Ticari (Adobe Connect) ve açık kaynak (OpenMeetings) Webinar uygulamalarının karşılaştırılması, *XIV. Akademik Bilişim Konferansı, 1-3 Şubat 2012*, Uşak Üniversitesi, Uşak.
- Gürol, M., & Atıcı, B. (2001). Uzaktan Eğitimden Uzaktan Öğrenme Anlayışına Dönüşmesinde WWW'nın Etkisi. *Bilişim Teknolojileri Işığında Eğitim (BTIE)*, 3-5 Mayıs 2001 (s. 133-138), ODTÜ Kültür ve Kongre Merkezi, Ankara.
- Işık, A. H., Karacı, A., Özkaraca, O., & Biroğlu, S. (2010). Web tabanlı eş zamanlı (senkron) uzaktan eğitim sistemlerinin karşılaştırmalı analizi, *XII. Akademik Bilişim Konferansı, 10-12 Şubat 2012*, Muğla Üniversitesi, Muğla.
- Knupfer, N. N., Gram, T. E., & Larsen, E. Z. (1997). Participant analysis of a multi-class, multi-state, on-line, discussion list. *Proceedings of Selected Research and Development Presentations at the 1997 National Convention of the Association for Educational Communications and Technology, February 14-18, 1997* (pp. 133-139)
- Mavridis, A., Tsiatsos, T., & Tegos, S. (2011). Exploiting web conferencing to support collaborative learning. *The Proceedings of 15th Panhellenic Conference on Informatics* (pp. 78-82), DOI 10.1109/PCI.2011.26
- McVay Lynch, M. (2002). *The online educator: A guide to creating the virtual classroom (RoutledgeFalmer studies in distance education)*. New York: NY, Routledge.
- Odabaşı, H. (2009). Mobil öğrenmeden mobil kütüphaneye. *ÜNAK 2009 Bilgi Çağında Varoluş: "Fırsatlar ve Tehditler" Sempozyumu, 01-02 Ekim 2009*, Yeditepe Üniversitesi, İstanbul
- Ozan, Ö. (2013). Bağlantıcı mobil öğrenme ortamlarında yönlendirici destek. *Yayımlanmamış Doktora Tezi*, Anadolu Üniversitesi Sosyal Bilimler Enstitüsü, Eskişehir.
- Özdamar Keskin, N. (2011). Akademisyenler için bir mobil öğrenme sisteminin geliştirilmesi ve sınanması, *Yayımlanmamış Doktora Tezi*, Anadolu Üniversitesi Eğitim Bilimler Enstitüsü, Eskişehir.
- Palloff, R. M., & Pratt, K. (1999). Building learning communities in cyberspace: Effective strategies for the online classroom, San Francisco, CA: Jossey Bass Publishers.
- Rayson, S., & Aberdour, M., (2009). *Virtual classrooms: An overview, Kineo Opensource*. [http://www.cedma-europe.org/newsletter%20articles/Kineo/Virtual%20Classrooms%20-%20An%20Overview%20\(Feb%2009\).pdf](http://www.cedma-europe.org/newsletter%20articles/Kineo/Virtual%20Classrooms%20-%20An%20Overview%20(Feb%2009).pdf), Erişim Tarihi: 01.04.2014.
- Snow, C., Pullen, J. M., & McAndrews, P. (2005). Network EducationWare: An open-source web-based system for synchronous distance education, *IEEE Transactions on Education*, 48(4), 705-712.
- Schullo, S., Hilbelink, A., Venable, M., & Barron, A. E. (2007). Selecting a virtual classroom system: Elluminate Live vs. Macromedia Breeze (Adobe Acrobat Connect Professional). *MERLOT Journal of Online Learning and Teaching*, 3(4), 331-345.
- Spencer, D. H., & Hiltz, S. R. (2003). A field study of use of synchronous chat in online courses. *The proceedings of 36th Hawaii International Conference on System Sciences*, <http://www.hicss.hawaii.edu/HICSS36/HICSSpapers/CLTSL03.pdf>, Erişim Tarihi: 26.04.2014.
- Şen, B., Atasoy, F., & Aydın, N. (2010). Düşük maliyetli web tabanlı uzaktan eğitim sistemi uygulaması, *XII. Akademik Bilişim Konferansı, 10-12 Şubat 2012*, Muğla Üniversitesi, Muğla.
- TÜİK (Türkiye İstatistik Kurumu). (2013). *Hanehalkı bilişim teknolojileri kullanım araştırması*. <http://www.tuik.gov.tr/PreHaberBultenleri.do?id=13569>, Erişim Tarihi: 18.04.2014.
- Wikipedia (2014). *Comparison of web conferencing software* http://en.wikipedia.org/wiki/Comparison_of_web_conferencing_software, Erişim Tarihi: 07.04.2014.

AN ANALYSIS OF MATHS LEARNING SUPPORT FOR MATURE STUDENTS IN ENGINEERING: ENGAGEMENT AND EFFECT.

Cormac BREEN
Dublin Institute of Technology
cormac.breen@dit.ie

Mark PRENDERGAST
Dublin Institute of Technology
mark.prendergast@dit.ie

Michael CARR
Dublin Institute of Technology
michael.carr@dit.ie

ABSTRACT: The Maths Learning Support Centre (MLSC) in the Dublin Institute of Technology (DIT) provides free mathematical support to all DIT students. This support is primarily delivered through a drop-in service, where students can receive one to one tuition in any area of mathematics. In the first semester of the 2013/14 academic year, a significant proportion of students enrolled in engineering programmes that availed of this drop-in service were mature students (approximately 42%) This is despite the fact that mature students constitute a relatively small proportion of the total student body (approximately 15%). This motivated the authors to examine the support offered to these students by the MLSC and also consider their attitudes towards this support. To this end focus groups were conducted in order to ascertain the attitudes of mature students in Engineering towards the MLSC. In addition some quantitative analysis was carried to determine what effect the MLSC had on student's academic performance.

Keywords: Mathematics Education, Mathematics Learning Support, Mature Students

INTRODUCTION

In recent years an increasing number of students in Irish Higher Educational Institutions (HEIs) are taking courses with mathematical and statistical elements. This is in part due to the widespread recognition that mathematics underpins many other disciplines (such as Science, Technology and Engineering) and the emphasis placed by the Higher Educational Authority on producing graduates who are highly literate in mathematics (EGFSN 2008, HEA 2004).

Hand in hand with this increase however has come the so called 'Maths Problem' - that is a decline in the mathematical proficiency of incoming first year students across HEIs in Ireland and elsewhere (Gill 2008, Almeida *et al.* 2012, Carr *et al.* 2013 & 2013). This in turn is having a detrimental effect on enrolment and retention levels in science and technology courses in HEIs (OECD 1999). In fact, it is widely acknowledged that the absence of a solid foundation in mathematics can be one of the key inhibitors for student progression in higher education (HEA 2008).

As part of the response to this problem, Maths Learning Support Centres (MLSCs), defined by Lawson *et al.* (2003) as '*a facility offered to students (not necessarily of mathematics) which is in addition to their regular programme of teaching through lectures, tutorials, seminars, problems classes, personal tutorials, etc.*' have been set up in the majority of HEIs in Ireland (Gill *et al.* 2010). In the UK over 85% of HEIs surveyed offer some form of Maths Learning Support (MLS) (Perkin *et al.* 2012), up from 62.3 % in 2004 and 48% in 2001 (Perkin *et al.* 2004, Lawson *et al.* 2001). It is therefore clear that MLS has now become an integral part of the higher educational framework, both in Ireland and the UK.

However despite this, MLSCs in several HEIs exist precariously, often lack permanent funding and are regularly in the 'front line' for spending cut backs (Macgillivray *et al.* 2011, Mac an Bhaird *et al.* 2013). To ensure that the limited funding available for MLS is put to the best possible use and to establish 'Best Practice', much time and resources have been put into researching methods of evaluating MLSCs' activities. This evaluation can be undertaken using quantitative (usage figures, diagnostic testing, exam results etc.) and qualitative methods (focus groups, surveys, student feedback etc.) (Macgillivray *et al.* 2011). In a study on evaluation of the MLSC in Dublin City University, Ní Fhloinn found that a combination of both types of methods gave a more complete

picture (Ní Fhloinn 2009). An extensive review of the literature on the evaluation of MLSCs can be found in (Matthews *et al.* 2012).

One important issue that arises from these evaluations is the non-engagement with MLS of so called ‘at risk’ students - those who are most in need of extra support. In a recent paper by Mac an Bhaird *et al.* (2013), details of a large scale study on student non-engagement with MLS across several Irish HEIs are given. The study found that the main reason students gave for non-engagement was that they did not need help. However this was more likely to have come from a student with a strong mathematical background. For the weaker ‘at risk’ students, issues with the structures of the MLS such as unsuitable opening hours or a lack of information were more likely to be cited as a reason for non-attendance. Symonds (2008) questions whether these reasons are valid and wonders if implementing the requested changes in structures would actually serve to increase the engagement levels of these students. This suggests that a deeper study into the reasons of student non-engagement with MLS, in particular for those ‘at risk’ students, is required to get to the root of the non-engagement problem.

In this paper, the authors seek to further this investigation by looking at the engagement levels of mature students with the MLSC in the Dublin Institute of Technology (DIT). In the DIT a mature student is defined as being ‘*any Irish or EU citizen who will be 23 years of age on the 1st of January of the proposed year of entry*’ (DIT Website). The authors examine qualitatively the reasons behind both the engagement and non-engagement of this cohort of students with the MLSC, as well as performing a quantitative study on the effect of the MLSC on these students’ academic performance.

METHODS

This study seeks to examine the reasons behind both the engagement and non-engagement of mature students with the MLSC in the DIT, as well as investigating how the MLSC has influenced the academic performance of mature students who have regularly availed of its services. The authors decided to use a mixed method approach by combining both quantitative and qualitative methods of research. Qualitative researchers are interested in understanding the meaning people have constructed from their lived experiences (Merriam, 2009). Hence, qualitative methods of enquiry and analysis are more suitable when humans are the instruments of enquiry. This is why the authors decided on a study of this nature. However, in order to evaluate the academic progress of mature students have been attending the Maths Support Centre a quantitative measure is needed. Much research supports this integration of quantitative and qualitative research. The use of multiple methods reflects an attempt to secure an in-depth understanding of the research and allows for broader and better results (Denzin and Lincoln, 2005).

Participants

The participants for this study comprised of mature students in their first year of an Engineering undergraduate programme in the DIT. As mentioned previously, in the DIT a mature student is defined as being ‘*any Irish or EU citizen who will be 23 years of age on the 1st of January of the proposed year of entry*’.

Qualitative Data

In order to get feedback regarding why students attend/do not attend the MLSC, two focus groups were conducted. The first group (Focus Group 1) was made up of mature students whose attendance in the MLSC was constant throughout the year. The second group (Focus Group 2) was made up of mature students who had never attended the MLSC. Each student was coded to ensure confidentiality. There were ten students in Focus Group 1 (P1 – P10) and four students in Focus Group 2 (P11 – P14). Their responses were transcribed and analysed using NVivo software and arranged into themes by the authors.

Quantitative Data

In order to get a quantitative measure of how the MLSC influenced the academic performance of mature students who regularly availed of its services, the authors decided to compare the grades of mature students who attended the MLSC with those who didn't. The objective was to investigate if the MLSC had any effect on their grades. The authors understand that there may have been other variables which may have affected the students’ grades throughout the year. The study focused on one particular group of students, who were undertaking their first year of an ordinary degree in mechanical engineering and compared the end of semester exam results of

those in this group who did and did not attend the MLSC in that semester. There were 20 mature students in this cohort. Of these students 8 had attended the MLSC and 12 had never attended.

RESULTS AND FINDINGS

Focus Group Findings

In this section the main themes that arose during the focus groups are outlined. There will be particular focus on the two topics most relevant to this paper namely what motives mature students to attend the MLSC and the reasons given by these students for non-attendance.

Motivation

During the course of the focus group, it became clear that the motivations of mature students who attend the MLSC were multi-faceted. The initial motivations that were raised were of a practical nature, such as financial motivation (not being able to afford private tuition) or simply a lack of availability of any other form of support

P1: *I didn't even do a Junior Cert and I'm doing mechanical engineering maths and I've had straight A's through and that's through the Learning Centre you know. I can't afford grinds you know.*

P2: *There's no other, no other help available. That's what I found. If you're looking for extra help as well, every door would be closed.*

An interesting theme that arose was the concept that it was the nature of mathematics itself, and its difference from other subjects, which motivated students to seek extra help. They experienced difficulties with self-study and keeping up with the pace of lectures.

P1: *Whereas maths, you have something at the start of a page and something at the end and if you don't understand the bit in the middle, unless somebody points their finger at it and says to you "this is what's happening". If you don't get it you don't get it.*

P1: *I find with maths in particular of all the subjects.....Unless you get a hold of the stuff in September and you're doing October's work you haven't a hope, if you don't understand the basics of stuff you haven't a hope. So I found going to the learning centre each week, staying on top, learning whatever was current, you'd go in and you'd actually learn from the lecture as well.*

Related to this theme, some students stated that while they found self-study aids (such as textbooks or online mathematical resources) useful, it was their belief that these aids are not a replacement for one-to-one support, such as that offered in the MLSC.

P2: *They're all fairly good but you still need the one-on-one. Because you can keep pausing and rewinding and going backwards and forwards but you need the one-on-one....When you've got no basic level there's only so much a video or a book can teach you*

A widely held view among the participants was that the mature students' life experiences serve to motivate them to seek out the extra support offered by the MLSC.

P7: *because I'm guessing most of us have experienced what it's like to struggle through jobs and that kind of stuff and realise the importance of getting a decent qualification behind you and doing something you actually like.....*

P7: *it's that experience of having been at the bottom, you know and having to try and survive at the bottom, that you realise that when you get an opportunity like this, just how important it is to really avail of all the services, in my opinion the Maths Learning Centre being the most important that I've come across so far as an extra aid on top of your coursework and stuff like that.*

It is a stated aim of the MLSC (MLSC website) is to provide MLS to students in an informal, relaxed and non-judgemental manner. Such an environment enables the students to raise their confidence in mathematics and hence develop as independent learners. The responses of the focus groups show that this goal is being achieved.

P10: *You can ask the question three or four times say if you still don't get it, there's no kind of feeling embarrassed to keep on asking, they'll keep on explaining it to you until you actually understand what your actually doing so it is, it's a very relaxed environment so I find it very good that way.*

Finally, the participants noted that they are not just interested in passing the exams, but that they wish to gain a deeper understanding of the subject. They recognise, again possibly based upon their life experiences, the importance of possessing more than just a surface level knowledge of their chosen subject area.

P9: *but I want to be able to understand it you know, I want to be able to like if I go to a job interview and somebody puts a problem in front of me I want to be able to know what it's about.....I want to comprehend it*

basically and if I need that extra bit of support, which you do get in the Maths Support Centre then I'll take advantage of it.

Reasons For Non-Engagement

This section outlines the main reasons given for the non-engagement of mature students with the MLSC. In a recent large scale survey on the issue of student non-engagement with MLS in Irish HEIs, it was found the main reason given by students who did not avail of service was that they did not believe they needed it (Mac an Bhaird *et al.* 2013). This finding was supported in our study.

P13: *I haven't really had a problem that I couldn't track down an answer to myself with google, youtube or any of that.*

Mac an Bhaird *et al.* (2013) found that the second most common reason given for non-attendance were issues with the structural organisation of MLS in their HEI e.g. opening hours, room size etc. This theme also arose during our study.

P13: *if it was at a different time during the day that would suit me.*

P7: *I found that the only thing that kind of stopped me from going was the size of the room and at certain times because of how packed it is*

In Irish HEIs, several programmes are run to ease the transition of mature students back to education. During the focus groups, it was noted that mature students who have attended one of these transition programmes, appear to have less of a need for the services of the MLSC than those who have entered directly into their undergraduate programme.

P13: *Some mature students have a problem I think. Since they finished the LC and come back into college it has been 5-10 years. Not studied anything... I did last year mechanical engineering, this year I am ok.*

P11: *I wasn't too bad because I did Fetac 5 last year and it had engineering maths in it as well.*

Quantitative Findings

The study focused on one particular group of students, who were undertaking their first year of an ordinary degree in mechanical engineering and compared the end of semester exam results of those in this group who did and did not attend the MLSC in that semester. There were 20 mature students in this cohort. Of these students 8 had attended the MLSC and 12 had never attended. Of the 8 students who attended, 2 dropped out of the course after the first few weeks so there was no data on their performance. For the 18 students who remained, their performance in the semester 1 maths module was compared (See Table 1).

The average mark of those who attended the MLSC was higher but not significantly so ($p=0.25$). It is not possible to determine if the two groups were the same or different to begin with as many of these students are international students, and many of the Irish students had not finished secondary school. Hence there is no single metric to compare their mathematical ability on entry. There is a DIT mathematics diagnostic test given to many students on entry but it was not given to this cohort.

Table 1: A Comparison Of End Of Semester Exam Results Of Those Who Did/Did Not Attend The MLSC.

Attended MLSC	N	Mean	Standard deviation
Yes	6	80.6	18.9
No	12	68.4	23

In addition, the proportion of the students who achieved a grade of more than 60% was examined (See Table 2). Using a two proportions test, there was a significant difference ($p=0.046$) between the students who attended the centre and those that did not.

Table 2: A Comparison Of End Of Semester Exam Results Of Those Who Did/Did Not Attend The MLSC Who Achieved A Mark Higher Than 60%.

Attended Centre	N	>60	< 60
Yes	6	6	0
No	12	9	3

It is a limitation of this study that this analysis was only for a small number of students in one course. The two students who attended but dropped out early are excluded and there is no metric for ranking the students on entry.

CONCLUSIONS

In this paper the authors investigated the reasons behind both the attendance and non-engagement of mature students with the MLSC in the DIT. Two focus groups were conducted with some interesting qualitative findings. The motivations of mature students were found to be multi-faceted, ranging from practical reasons, such as financial motivation, to more complex reasons such as their life experiences as adults motivating them to seek out extra help. The notion that mature students are interested not just in passing their exams, but also in gaining a deeper understanding of their chosen subjects was raised. The importance of one-to-one support in a student's development as an independent learner, even with the widespread availability of online resources, was also stressed.

For those students who did not avail of the services offered by the MLSC, the reasons given were mostly in line with the literature (Mac an Bhaird *et al* 2013), for example a lack of need for the service or issues with the structures of the MLSC. An interesting point raised was that mature students who have had a transition year prior to beginning their programme may have less need for extra support than those who have not attended such a course.

On the quantitative side, the authors examined the end of semester exam results of one group of students. They found that while the mean grade of those who attended the MLSC was higher than those who did not, the difference was not statistically significant ($p=0.25$). However when the results of those who got over 60% in the exam were compared, a significant difference ($p=0.046$) in the grades of those who attended compared to those who did not was found. These results must be viewed with a certain amount of caution however, as there was no common baseline for comparison of students' exams scores (e.g. diagnostic test results) and the sample size was small (18 students).

FUTURE WORK

The main question that arises when considering the positive engagement levels of mature students is why there are not similar engagement levels with traditional students. To investigate this further the authors intend to extend the work contained in this paper to include traditional students. The authors also wish to extend the quantitative analysis of this study to a much larger group of students as well as to benchmark students on entry using the DIT maths diagnostics test, in line with Carr *et al.* (2013).

REFERENCES

- Almeida, B .D, Fidalgo, E., Rasteiro C., D.M.L.D., Projeto "ACAM - Avaliação de Competências / Ações de Melhoria", *XIX Colóquio AFIRSE: Revisitar os estudos Curriculares : onde estamos e para onde vamos ?*, 2012.
- Carr, M., Bowe, B., & Ni Fhloinn, E. "Core Skills Assessment to improve mathematical competency", *European Journal of Engineering Education*, pp.1-12, 2013.
- Carr, M., Ni Fhloinn, E., Murphy, E. & Bowe, B. Addressing continuing mathematical deficiencies with advanced mathematical diagnostic testing. *Teaching Mathematics Applications* (2013) 32 (2): 66-75.
- Denzin, N.K. and Lincoln, Y.S. (2005). *The SAGE Handbook of Qualitative Research*, USA: Sage Publications
- Dublin Institute of Technology (DIT) [online], (Retrieved April 2014 from <http://www.dit.ie/study/mature/prospective/>)
- Expert Group on Future Skills Needs. (2008) Statement on Raising National Mathematical Achievement. Retrieved April 2014 from http://www.skillsireland.ie/media/egfsn090616_statement_on_activity.pdf)
- Gill, O., Johnson, P. & O'Donoghue, J. (2008) An Audit of Mathematics Support Provision in Irish Third Level Institutions. CEMTL (Regional Centre For Excellence in Mathematics Teaching and Learning), University of Limerick.
- Gill, O., O'Donoghue J., Faulkner, F. & Hannigan A. (2010) Trends in performance of science and technology students. *International Journal of Maths Education, Science and Technology*, 41, 323-339.
- A Study in Progression in Irish Higher Education, HEA 2010. Retrieved April 2014 from http://www.heai.ie/sites/default/files/study_of_progression_in_irish_higher_education_2010.pdf
- National Strategy for Higher Education to 2030, January 2011 Retrieved April 2014 from http://www.heai.ie/sites/default/files/national_strategy_for_higher_education_2030.pdf
- Lawson, D., Croft, T. & Halpin, M. (2001) Evaluating and Enhancing the Effectiveness of Mathematics Support Centres. Final report of a project funded by the LTSN Maths, Stats and OR Network. Retrieved April 2014 from

http://www.academia.edu/2715644/Evaluating_and_Enhancing_the_Effectiveness_of_Mathematics_Support_Centres

- Lawson, D., Croft, A.C. & Halpin, M. (2003) Good practice in the provision of mathematics support centres, learning and teaching in mathematics, statistics and operational research. LTSN Maths, Stats & OR Network, (Retrieved April 2014 from <http://www.mathcentre.ac.uk/resources/Good%20Practice%20Guide/goodpractice2E.pdf>).
- Mac An Bhaird, C., Fitzmaurice, O., Ní Fhlóinn, E. & O'Sullivan, C. (2013) Student non-engagement with mathematics learning supports *Teaching Mathematics and Its Applications* (2013) 32, 191-205
- Macgillivray, H. & Croft, A. C. (2011) Understanding evaluation of learning support in mathematics and statistics. *Int. J. Math. Educ. Sci. & Tech.*, 42, 189-212.
- Matthews, J., Croft, T., Lawson, D. & Waller, D. (2012) Evaluation of Mathematics Support Centres – A Review of the Literature. sigma, Coventry: Coventry University. Retrieved April 2014 from <http://www.mathcentre.ac.uk/resources/uploaded/52487-evaluation-of-msc-7.pdf>
- Merriam, S.B. (2009). *Qualitative Research: A Guide to Design and Implementation*, San Francisco: Jossey – Bass Publishers.
- Mathematics Learning Support Centre- Aims [online] Retrieved April 2014 from <http://www.maths.dit.ie/mlsc/aims.html>
- Ní Fhlóinn, E. (2009) The role of student feedback in evaluating mathematics support centres. *CETL-MSOR Conference 2009 Proceedings*, 94-98, Retrieved April 2014 from http://www.mathstore.ac.uk/headocs/Proceedings_2009_Upload_0.pdf
- Organisation For Economic Co-Operation And Development (OECD). (1999) *Measuring Student Knowledge and Skills: A New Framework for Assessment*. Paris: OECD.
- Perkin, G. & Croft, T. (2004) Mathematics Support Centres – the extent of current provision. *MSOR Connections*, 4 (2) 14-18.
- Perkin, G., Lawson, D. & Croft, T. (2012) Mathematics Learning Support in Higher Education: the extent of current provision in 2012. sigma, Coventry: Coventry University. (See <http://www.mathcentre.ac.uk/resources/uploaded/52789-mls-in-uk.pdf>)
- Symonds, R. (2008) *Evaluating Students' Engagement with Mathematics Support*. PhD Thesis. Loughborough University.

WEB BASED EDUCATIONAL SOFTWARE FOR ARTIFICIAL NEURAL NETWORKS

Tuncay YİĞİT

Dept. of Computer Engineering, Suleyman Demirel University
tuncayyigit@sdu.edu.tr

Ali Hakan IŞIK

Dept. of Computer Engineering, Mehmet Akif Ersoy University
ahakan@mehmetakif.edu.tr

Mehmet BİLEN

Çavdır Vocational High School, Mehmet Akif Ersoy University
mbilen@mehmetakif.edu.tr

ABSTRACT: Artificial Neural Networks (ANN) is an important data processing algorithm for students, researches, scientist, mathematicians, academicians and engineers which is inspired by human brain and human brain's learning methods. Complex nature and mathematical structures of ANN makes it difficult to learn. Due to this reason, new methods have to be employed to teach ANN. In this study, we design and develop web based educational software which combines advantages of examined works to teach artificial neural networks with the support of multimedia course content. In addition, relevant studies such as Neuro-Lab, EasyLearnNN, NeuroFuzz and related most popular professional commercial tools such as MATLAB, Statistica, Mathematica, NeuroSolutions, JOONE are also examined. Developed software will help researchers from students to scientist to train, test an ANN model and understand fundamentals of ANN.

Key words: artificial neural networks, simulation, web based

INTRODUCTION

ANNs are physical celled systems which imports, stores and uses experimental knowledge [1]. A neural network is a massively parallel distributed processor made up of simple processing units, which has a natural propensity for storing experiential knowledge and making available for use [2]. On the other hand, ANN is a computer program which simulates biological neural networks. ANNs through these features can solve optimization, classification, prediction, pattern recognition, associative memory and control problems effectively and easily [3-5].

Therefore ANNs are increasingly including in the Curricula of many engineering lessons at graduate and undergraduate level. But beside these problem solving skills, because of complex and mathematical nature ANNs are very hard to understand systems and algorithms for students which are also studying in engineering. Moreover, ANNs evolves during their design and training phases because of dynamic structure [6]. Traditional teaching approaches like classroom-teaching, books, lecture notes cannot help properly students to learn basics and working mechanisms of ANNs. At this point computer based teaching approaches like simulation software's provide an easy to use and understand environment to visualize working mechanism, designing and training phases of ANNs by students.

RELATED WORKS

MATLAB is a high level technical computing language and environment which is including a lot of tools for developing algorithm, analyzing data, computing complex mathematical formulas. Beside these tools MATLAB has also an ANN tool which named Neural Network Toolbox that providing environment to work with ANN. It supports a lot of most popular ANN models and related learning algorithms.

Statistica is a kind of statistic and analyze software which has many different integrated tools. Also Statistica has a tool for ANN like MATLAB. This tool provides easy to use environment to work with many wide used ANN models. Beside this, it helps users to design and develop suitable ANN models for solving their own problems.

NeuroSolutions is graphical neural network development tool that enable users to create ANN model for a particular user data. It has a lot of advanced input, attribute selection techniques like Genetic Optimization, Greedy Search, Back-Elimination, learning procedures like Levenberg-Marquart algorithm. It also supports programmers who are implementing their own application with Windows-based DLLs or source code.

Mathematica is another software that using by students and professionals for design and develop their own ANN models. This software also supports most common ANN models like MLP, SOM and Hopfield Network.

JOONE is open source development software which is designed by Java programming language. It is composed by a core engine, GUI editor and distributed training environment. It can be extended from programmers by implementing new modules to add new ANN models and relevant learning algorithms.

NeuroFuzz is an internet based ANN simulation tool [7]. So users can access it with a popular web browser from anywhere. The tool aims to teach working mechanism and fundamentals of ANN by give tasks to users and allow them solve problems with support of graphical features.

Internet based simulation software EasyLearnNN which including most popular ANN algorithms like MLP, SOM, LVQ, was developed to use in education of ANN [8]. Working environment in the software that used design and develop ANN, represent all parts of ANN with a colorful graphical interface to allow students to use software in an intuitive and enjoyable way.

Neuro-Lab is a software-based environment to teach ANN was designed for support exploratory education in the artificial intelligence courses [6]. It allows users to change all properties of a network by graphical interface and trace how outputs are changing.

Yapay Sınır Ağları Eğitim Materyali is an educational tool for ANNs which is implemented with object oriented approach [9]. The tool has modules to add layer, neuron and select activation function, related learning algorithm. It allows users trace every step of training and test phases. Users can learn and gain experience of ANN with Effective and exploratory learning techniques by this software.

Although some of mentioned before are quite professional software's, most of them are not suitable for educational purpose because of these have complex design, distractive interface, a lot of irrelevant knowledge and features. On the other hand some of these are really effective to learn working mechanism and fundamentals of ANN. But we aims to design and develop software which is combined advantages of different related software's and help users to learn ANN properly.

METHOD

The software was developed in a modular way and these modules were put in learning and simulation panels.

3.1. Simulation panel

This panel is includes simulation, graphics and animation, data set import and examine modules.

Users can easily add data sets to learn or test of ANN by using data set import and examine modules. Developed system supports widely used file formats like .csv, .xls, .txt and .xml. Also it is considered difference punctuations. For example some countries use "." but some of them use "," to show decimal numbers. The other considered thing when implementing the system is converting class outputs to numerical values.

Users can use ANN simulate module which is the most important part of the system for understand working mechanism of an ANN. At this module, users can change parameters which is necessary to train a network, trace how the network acts. Simulate module and an example can seen in Figure 1.

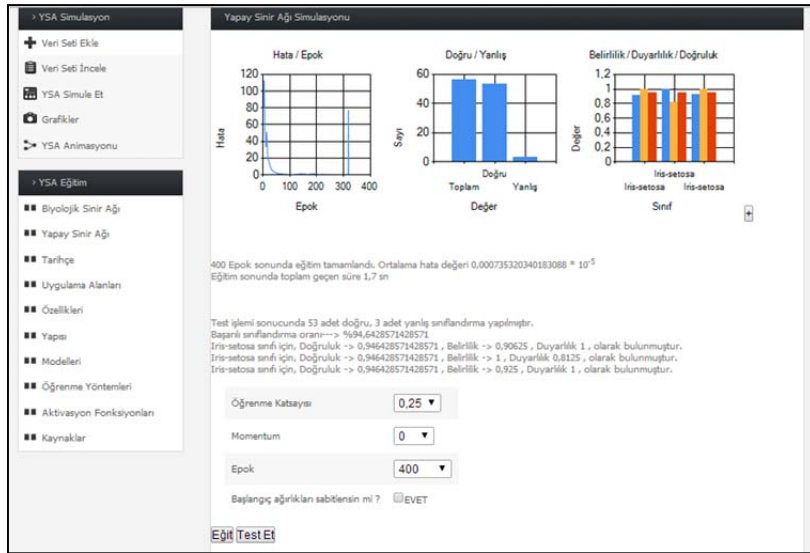

Figure 1. ANN Simulate Module

There is three different graphics top of the module, so users can trace training and test phrases. The graphic named Error / Epok is used for show error of the network epok by epok. True / False shows the results according to the test phrases. The last graphic named Performance graphic shows each class's determinacy, sensitivity and accuracy values.

Training of an ANN is a process occurs with the updating weights between neurons but it is very important to choose the initial values of the parameters during training phrase because the effect of parameters related to the output cannot predict before. Due to dynamic nature of ANN, the effect of parameters related to the output parameters can vary. Therefore, it is not easy to teach ANN by classical techniques. The system allows users to change parameters like learning rate, momentum, epok count by using controls in the module understand. How the network acts in different learning rate and momentum values easily can be seen by students like in the Figure 2. and Figure 3.

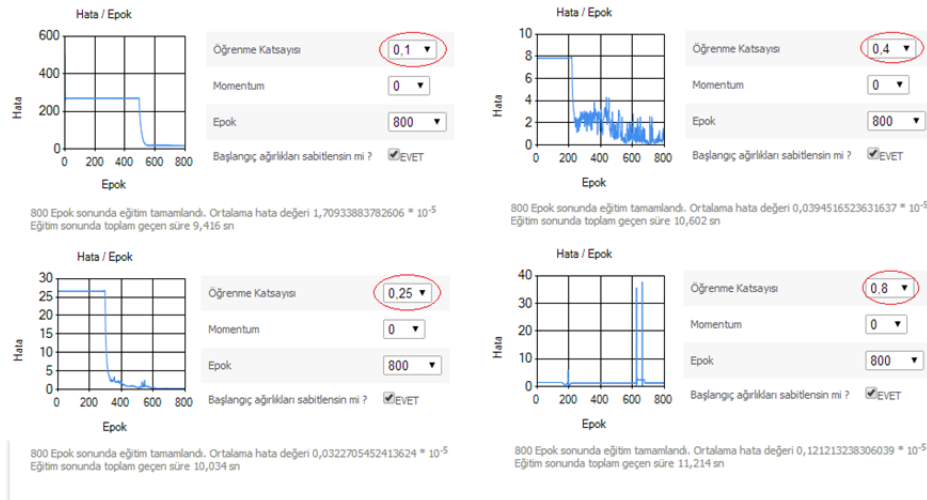

Figure 2. Results according to different learning rate values

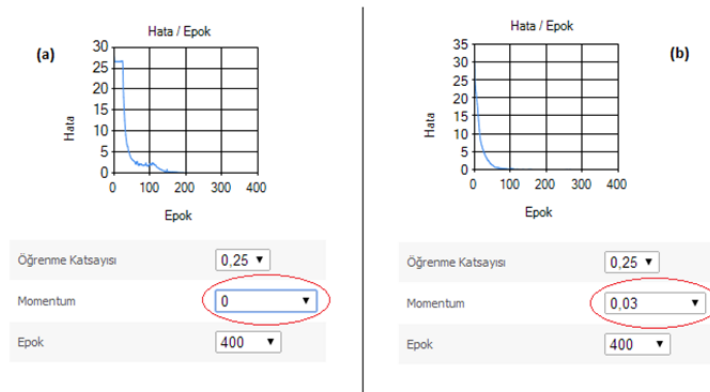

Figure 3. Results according to different momentum values

Users can easily save trained network and outputs, access these data's by graphic module.

Animation of a simple ANN can be watch in the animation module. So users can learn effectively by using both simulation and animations.

3.2 Education Panel

Users can access a lot of document from basics to training of ANNs to learn foreknowledge.

CONCLUSION

We designed easy to use, modular infrastructured, multimedia supported such as flash animation, web based educational software for ANN which can be accessed from anywhere at any time in the world. Developed software uses web 2.0 technologies such as XML, AJAX. It is used for two semesters in artificial intelligence lessons given at Çavdır Vocational High School in Turkey. %95 of these students thinks an educational tool is really useful to understand ANNs properly. According to %90 of these students, the developed software helps students to understand basics of ANNs easily and effectively.

REFERENCES

- Şağiroğlu, Ş., Beşdok, E., Erler, M., 2003. Mühendislikte Yapay Zeka Uygulamaları - I Yapay Sinir Ağları. Ufuk Yayınevi, 426s, Kayseri.
- Haykin, S., 1999. Neural Networks: A comprehensive foundation. Prentice-Hall, 768p, New Jersey.
- Blanton, H., 1997. An introduction to neural networks for technicians, engineers and other non PhDs. 9-12 November, Proceedings of the 1997 Artificial Neural Networks in Engineering Conference. St. Louis.
- Fulcher, J., 1992. Experience with teaching a graduate neural networks course. Computer Science Education, 297-314.
- Fulcher, J., 1998. Laboratory support for the teaching of neural networks. International Journal of Electrical Engineering Education, 29-36
- Rosello, E., Perez-Schofield, J. B., Dacosta, J., Perez-Cota, M., 2003. Neuro-Lab: A Highly Reusable Software-Based Environment to Teach Artificial Neural Networks. Computer Applications in Engineering Education, 11(2), 93- 102.
- Manic, M., Wilamowski, B., Malinowski, A., 2002. Internet based neural network online simulation tool. Industrial Electronics Society, IEEE 2002 28th Annual Conference, 5-8 November, Sevilla, 2870-2874.
- Uğur, A., Kınacı, A., 2010. A web-based tool for teaching neural network concepts. Computers Applications in Engineering Education, 18 (3), 449- 457.
- Deperlioğlu, Ö., Köse, U., 2011. An educational tool for artificial neural networks. Computers and Electrical Engineering, 37, 392-402.

MATEMATİK ÖĞRETMENLİĞİ ALAN BİLGİSİ SINAVLARINDAKİ SORULARIN MATH TAKSONOMİ ÇERÇEVESİNDE ANALİZİ

H. Sevgi MORALI
Dokuz Eylül Üniversitesi
sevgi.morali@deu.edu.tr

Hakan KARADUMAN
Dokuz Eylül Üniversitesi
hakankaraduman.deu@gmail.com

Işıkhan UĞUREL
Dokuz Eylül Üniversitesi
isikhan.ugurel@deu.edu.tr

ÖZET: Öğretmenlerin mesleğe adım atmadan önce ve mesleğe başladıktan sonra tabi tutuldukları alan bilgisi sınavlarının mesleki yeterlilik açısından önemli yer tuttuğu bilinmektedir. Söz konusu sınavlarda yönlendirilen soruların içerikleri ve kategorik olarak dağılımları bu sınavların amacına ulaşmasında belirleyici unsurlardandır. Dolayısıyla alan bilgisini ölçmeye yönelik yapılan sınavlarda yer alan soruların incelenmesi hem yapılan sınavların genel durumunu betimlemek hem de ileride yapılacak olan sınavlar için öneriler sunmak adına araştırılması gereken bir konudur. Bu çalışmada ülkemizde yapılan ve matematik alan bilgisini ölçmeyi amaçlayan sınavlardaki sorulara dönük bir analiz gerçekleştirilmiştir. Soruların analizi için Smith ve ark. (1996) tarafından geliştirilen MATH Taksonomi'den yararlanılmıştır. Çalışmanın birinci aşamasında, her üç sınavın matematik soruları iki yazar tarafından tek tek bireysel olarak taksonomi çerçevesinde analiz edilmiştir. İkinci aşamada üç yazar bir araya gelerek analizleri üzerinde ortak inceleme yapmış ve tutarlılık seviyesine bakarak var olan ayrışmalar üzerinde tartışmışlardır. Yazarların bireysel incelemelerindeki soru dağılımlarının tutarlılığı %80 civarında bulunmuştur. Çalışmadaki temel sonuç üç sınavda da soruların büyük oranda A kategorisinde sorulmuş olmasıdır.

Anahtar sözcükler: matematik öğretmeni, alan bilgisi, alan bilgisini ölçme, MATH taksonomi.

ABSTRACT: It is known that the field knowledge exams that teachers are subjected to, before and after they enter the profession, play an important role in assessing professional competence. The categorical range of said questions according to their content is a determining factor in the success of these exams. Therefore, examining the questions asked in field knowledge exams is necessary, both to acquire a general understanding of the current exams and to offer suggestions for the future. In this study we have produced an analysis of the questions intending to evaluate mathematical field knowledge in our country. The MATH (Mathematical Assessment Task Hierarchy) Taxonomy developed by Smith et. al., (1996) was used for the analysis of the questions. In the first stage of the study, the questions of all three exams have been analyzed separately by two writers within the framework of the taxonomy. In the second stage the three writers have come together for a joint examination of their analyses and discussed the differences with regards to the level of coherency. The coherency of the separate examination of the writers has been found to be around 80%. The main result is that to a high extent the questions have been asked in the category of A.

Key words: Mathematics teacher, content knowledge, assessing content knowledge, MATH taxonomy.

GİRİŞ

Matematik bilimde, teknolojiye ve günlük hayatımızda önemli bir enstrümandır. Matematiğin disiplinler arası bağlayıcı bir bilim dalı olmasının bilimin gelişmesinde ve teknolojik ilerlemelerde önemli bir katkısı olduğu bilinmektedir. Dolayısıyla günümüzde matematik bilmek ve öğrenmek temel bir gereksinim haline gelmiştir. Bu gereksinimi sağlamada en önemli rol şüphesiz öğretmenlerindir. Matematik öğrenmede rehber ve danışman niteliğindeki öğretmelerin bilgi ve becerilerinin dikkatle planlanması ve ölçülmesi gerekmektedir. Söz konusu ölçüm için ülkemizde öğretmenlerin mesleğe başlamadan önce ve sonrasında uygulanan bazı sınavlar bulunmaktadır. Bunlardan biri KPSS (Kamu Personeli Seçme Sınavı) olup bu sınavda genel kültür ve mesleki yeterlilik sınavları uygulanmaktadır. KPSS'de 2013 yılından itibaren ÖABT (Öğretmenlik Alan Bilgisi Testi) ile alan bilgisi ölçülmeye başlanmıştır. Alan bilgisinin ölçülmesini içeren bir diğer sınav öğretmenlerin meslek içinde tabi tutuldukları Fen, Sosyal Bilimler, Güzel Sanatlar ve Spor Liseleri ile Her Türdeki Anadolu Liseleri Öğretmenlerini Seçme Sınavı'dır. Bu tür sınavlarla meslek öncesinde ve mesleğini icra esnasında alan bilgisi

açısından daha iyi seviyede olan öğretmenlerin seçimi amaçlanmaktadır. Ancak bu özellikle test tipindeki sınavlarla gerçekleştirilmesi kolay olmayan bir amaçtır. Buna karşın yine de test tipindeki sınavlardan tümüyle vazgeçmek de mümkün görünmemektedir (Uğurel, Moralı ve Kesgin, 2012). Öğretmen adaylarının alan bilgilerini ölçmeye dönük sınavlarda matematiksel bilginin nasıl ölçülmesi gerektiği son derece önemli bir sorudur. Peşi sıra başka sorularda gündeme gelebilir. Örneğin; “uygulanmakta olan bu sınavlardaki soruların sayısı, çeşidi ve niteliği yeterli midir? Bilgi düzeylerinin derinliği uygun mudur?” Sınavların kapsamı lisans öğreniminin başarısını ya da yeterliliğini ölçmeye uygun mudur?” Bu ve benzeri sorulara cevaplar sunmak, bu tür sınavlara yönelik politikaları belirleyen, sınavları hazırlayıp uygulayan resmi kurumların görevidir. Bununla beraber araştırmacıların da bu sorulara bilimsel yanıtlar araması gerekmektedir.

Biz bu düşünceden hareketle söz konusu sınavlara yönelik bir incelemeyi sunduğumuz bu çalışmayı gerçekleştirdik. Çalışmamızda yukarıda sözü edilen iki sınavdaki matematik alan bilgisi sorularının analizi için Smith ve arkadaşları (1996) tarafından geliştirilen MATH (Mathematical Assessment Task Hierarchy) Taksonomi (MT) temel alınmıştır. Matematiğe özgü olarak geliştirilen bu taksonomi ile daha sağlıklı bir değerlendirme yapmak mümkün olabilmektedir.

MATH Taksonomi

Smith ve arkadaşları (1996) becerileri ve kavramları test eden soruları içeren sınavları oluşturmak için bir taksonomi kullanmışlardır (Uğurel, Moralı ve Kesgin, 2012). Bu taksonomi MATH (Mathematical Assessment Task Hierarchy) Taksonomi (MT) olarak bilinmektedir. Bloom taksonomisinin matematiğe uyarlaması olan bu taksonomi matematik alanına yönelik yapılacak sınıflamalara daha uygun görülmektedir. MT, öğrencilerden göstermeleri istenen bilgi, beceri ve yeteneklerin ölçülüp ölçülmediğinin belirlenmesi için bir kontrol sağlar (Wood, Smith, Petocz ve Reid, 2002). Böylelikle yapılan sınıflama ile sınavlarda yönlendirilen soruların içerikleri ve kategorik olarak dağılımları sınavların amacına ulaşmasında belirleyici olmaktadır. MT’de A, B ve C olmak üzere üç grup ve her bir grubun kendi içerisinde var olan toplamda sekiz alt kategori bulunmaktadır (Wood & Smith, 2002). **A grubu:** bilgi ve bilgi sistemi, anlama ve rutin işlemleri, **B grubu:** bilgi transferi ve yeni durumlara uyarlama, **C grubu:** doğrulama ve yorumlama, çıkarımlar tahminler ve karşılaştırma ve değerlendirme kategorilerini içermektedir.

Şekil 1. MT Hiyerarşisi



(Uğurel, Moralı ve Kesgin, 2012: 428)

uygulayabilme yeteneğini test etmektedir. **C grubu kategorileri** ise bir sonucu doğrulamayı, doğrulama, değerlendirme ve yargılamayı birlikte karşılaştırma ve çıkarımlar yapmayı kapsamaktadır (D'Souza & Wood, 2003:2 den aktaran Uğurel, Moralı ve Kesgin, 2012).

Analizi Yapılan Sınavlar

KPSS'ye yönelik 2012 yılında ÖSYM tarafından yapılan açıklamada aşağıdaki bilgilere yer verilmiştir.

Milli Eğitim Bakanlığında öğretmen istihdamı, KPSS Eğitim Bilimleri Testinin neticelerine göre gerçekleştirilmekle birlikte Bakanlığımızın talebi üzerine, MEB, ÖSYM ve Devlet Personel Başkanlığı (DPB) arasında, “Kamu Görevlerine İlk Defa Atanacaklar İçin Yapılacak Sınavlar Hakkında Genel Yönetmelik” kapsamında bir protokol imzalanarak aşağıda listesi verilen alanlarda öğretmenlerin atanabilmesi için KPSS Eğitim Bilimleri Testinin sonuçlarına ek olarak öğretmenlerin alan bilgilerinin de ölçülmesi amacı ile Öğretmenlik Alan Bilgisi Testi sonuçlarının da dikkate alınarak atamaların gerçekleştirilmesi kararlaştırılmıştır. Bu kapsamda, 2013 yılında Türkçe, **İlköğretim Matematik**, Fen Bilimleri/ Fen ve Teknoloji, Sosyal Bilgiler, Türk Dili ve Edebiyatı, Tarih, Coğrafya, **Matematik** (Lise), Fizik, Kimya, Biyoloji, Din Kültürü ve Ahlak Bilgisi, Yabancı Dil (Almanca, Fransızca, İngilizce) alanlarında Öğretmenlik Alan Bilgisi Testinin

(ÖABT) yapılmasına karar verilmiştir ÖSYM (2012).

Bu kapsamda 2013 yılında KPSS Matematik (Lise) Öğretmenliği (S1) ve İlköğretim Matematik Öğretmenliği (S2) branşlarında alan bilgisi testi uygulanmıştır. Bu testlerin içeriği: Alan Bilgisi Testi ve Alan Eğitimi Testi olarak belirlenmiştir. Testlerin her birinde 50 adet soru bulunmaktadır. Bunlardan 40'ar adedi Alan Bilgisi Testi'ne aittir.

İncelediğimiz diğer sınav farklı özelliklerdeki okullara atama yapmak için uygulanmakta olan Fen, Sosyal Bilimler, Güzel Sanatlar ve Spor Liseleri ile Her Türdeki Anadolu Liseleri Öğretmenlerini Seçme Sınavı'dır (S3). Farklı özelliklerdeki okullara atama sınavı diyebileceğimiz bu sınav en son 2012 yılında uygulanmış olup sınavda özel alan bilgisi olarak 50 soru yöneltilmiştir. Çalışmamızda soruların analizlerini yapmak üzere hem zamanlarının yakın olması hem de içeriklerinin benzerlik göstermesi sebebiyle bu üç sınav seçilmiştir. Seçilen sınavlardaki soruların kapsamı (lisans düzeyi) ile taksonomidekiler oldukça paraleldir ve sağlıklı bir incelemeye olanak sağlamaktadır. MT'nin oluşturulmasında ve içerisindeki kategorilerin örneklenmesinde tamamen üniversite düzeyinde matematik konuları temel alınmıştır. Seçilen sınavlardaki soruların kapsam ve dağılımları aşağıdaki tablolarda sunulmuştur.

Tablo 1. 2013 KPSS Alan Bilgisi Testi Matematik (Lise) Öğretmenliği ve İlköğretim Matematik Öğretmenliği Soru Kapsam ve Dağılımı

Lise Matematik Öğretmenliği				İlköğretim Matematik Öğretmenliği			
	Soru sayısı	Yaklaşık ağırlık (%)	Genel yüzde		Soru Sayısı	Yaklaşık ağırlık (%)	Genel yüzde
Alan Bilgisi Testi	40		80	Alan Bilgisi Testi	40		80
Analiz	12	24		Analiz	14	28	
Cebir	8	16		Cebir	9	18	
Geometri	8	16		Geometri	9	18	
Uyg. Matematik	12	24		Uyg. Matematik	8	16	
Alan Eğitimi Testi	10		20	Alan Eğitimi Testi	10		20

(ÖSYM, 2013)

Tablo 2. Fen, Sosyal Bilimler, Güzel Sanatlar ve Spor Liseleri ile Her Türdeki Anadolu Liseleri Öğretmenlerini Seçme Sınavı Soru Kapsam ve Dağılımı

Sınavın Kapsamı	Yüzde (%)
Özel Alan Bilgisi	50
Analiz	22
Cebir	9
Geometri	8
Uyg. Matematik	11
Öğretmenlik Meslek Bilgisi	15
Atatürk İlk. Ve İnkılap Tarihi	15
Türkçe	20

(MEB, 2010)

Tablolar incelendiğinde KPSS'deki soruların konu dağılımlarının genel hatları ile birbirine paralel olduğu, farklı okul türlerine yönelik yapılan sınavda ise analiz konularında daha fazla soru bulunduğu gözlenmektedir. 1. ve 2. sınavda 40'ar soru, 3. sınavda ise 50 soru bulunmaktadır. Aradaki fark analiz konularında artış sağlamıştır.

MT'ye Yönelik Yapılan Çalışmalar

MT'ye yönelik ilk çalışma Smith ve arkadaşları (1996) tarafından yapılmıştır. Smith ve arkadaşları bu çalışmalarında MT'ye neden ihtiyaç duyulduğunu, MT'nin matematikte kullanımının yararlarını, MT'yi oluşturan kategorileri ve her bir kategoride gerçekleştirilmesi gereken aktiviteleri tanımlamışlar ve bu

aktivitelerin daha iyi anlaşılmasını sağlayacak olan örnek soruları sunmuşlardır (Uğurel, Morali ve Kesgin, 2012). Bu çalışma dışında başka çalışmalarda bulunmaktadır. Bunlara, Wood ve Smith (2002), Wood, Smith, Petocz ve Reid (2002), Leinbach, Pountney ve Etchells (2002), Rizvi (2007), Blanco, Estela, Ginovart ve Saà (2009), Kesgin (2012) örnek gösterilebilmektedir.

Ülkemizde ise MT'ye yönelik ilk çalışma Uğurel ve arkadaşları (2012) tarafından gerçekleştirilmiştir. Uğurel ve arkadaşları çalışmalarında MT'yi tanıtarak OKS, SBS ve TIMSS matematik sorularını MT çerçevesinde karşılaştırmalı bir analizini yapmışlardır. Literatür incelendiğinde MT hem matematik hem de diğer alanlarda öğrenme durumlarının ölçümüne yönelik işlevsel ve etkin bir çerçeve sunduğu (Uğurel, Morali ve Kesgin, 2012) ifade edilebilir.

Bu çalışmadan yola çıkarak bizler, ülkemizdeki matematik öğretmenliği alan bilgisinin ölçüldüğü üç sınavın soruların MT çerçevesinde bir analizini yapmayı amaçladık.

YÖNTEM

Bu araştırma ülkemizde uygulanan ve matematik öğretmenlerinin alan bilgisini ölçmeyi amaçlayan sınavlardaki sorulara yönelik bir betimsel incelemesidir. Veri grubunda sırasıyla 40, 40, 50 adet soru bulunmaktadır. Sınavlarla ilgili soru sayıları ve yüzdeler dağılımları tablo 1 ve 2 de verilmiştir.

Analiz

Çalışmamızda toplam üç sınavdan 130 adet soru incelenmiştir. Çalışmanın birinci aşamasında, ilk iki yazar her üç sınavın matematik soruları tek tek bireysel olarak taksonomi çerçevesinde analiz etmiştir. İkinci aşamada bu yazarlar bir araya gelerek analizlerini karşılaştırmış ve ortak incelemelerinde tutarlılık olmayan maddeler üzerinde tartışmışlardır. Bu aşamada üçüncü yazar da bulunmuş ve güvenilirliği arttırmak için özellikle uyum olmayan sorularda inceleme ve görüşlerini sunmuştur. Böylece güvenilirliğin artırılması sağlanmıştır. Tartışmalar oturumu her soru için fikir birliğine varıncaya kadar devam etmiştir. İki yazarların bireysel incelemelerinde, soruların MT ye yönelik kategorizasyonundaki tutarlılık oranı %80 civarında bulunmuştur. Daha sonra üç yazar tarafından sorular bir kez daha baştan sona incelenmiş ve kategorilere göre sınıflandırılmıştır. Elde ettiğimiz bulgular aşağıda sunulmakta ve alan bilgisinin ölçümü kapsamında tartışılmaktadır.

BULGULAR VE YORUM

İncelenen soruların MT çerçevesinde dağılımı için Tablo 3 oluşturulmuştur. Tabloda seçilen üç sınavdaki soruların MT kategorilerine göre sayısı ve yüzdeleri verilmiştir.

Tablo 3. Seçilen Sınavlardaki Soruların MT Çerçevesinde Sayısal ve Yüzdeler Dağılımları

Sınavlar		A1	A2	A3	B1	B2	C1	C2	C3
S1	sayı	3	9	21	6	1	0	0	0
	yüzde	%7,5	%22,5	%52,5	%15	%2,5	%0	%0	%0
S2	sayı	4	3	31	0	0	0	2	0
	yüzde	%10	%7,5	%77,5	%0	%0	%0	%5	%0
S3	sayı	2	2	35	8	1	2	0	0
	yüzde	%4	%4	%70	%16	%2	%4	%0	%0

S1 de en çok A kategorisinde soru varken, bunu B kategorisi izlemektedir. Bu sınavda C kategorisinde hiç soru bulunmamaktadır. S2 de ağırlıklı olarak A kategorisinde soru varken, B kategorisinde soru bulunmamaktadır. Ancak S1'in aksine S2'de C kategorisinde de 2 sorunun yer aldığı görülmektedir. S3'te yine ağırlıklı olarak A kategorisinde soru varken, bunu sırasıyla B ve C izlemektedir. S3'de diğer iki sınavdan farklı olarak her üç kategoride de soru bulunmaktadır. Üç sınavda da ortak olan nokta en fazla A, en az C kategorilerinde soru olmasıdır. Üç sınavın kategorilere göre genel soru dağılımı S1 için A da 33, B de 7, C de 0; S2 için A da 38, B de 0, C de 2; S3 için A da 39, B de 9 ve C de 2 dir. İlk kategoride soruların daha çok A3 de, ikinci kategoride ise B1 de toplandığı görülmektedir. Bu durumda üç sınavda da soruların büyük oranda A kategorisinde olacak şekilde sorulduğu ifade edilebilir. Soruların tamamını alt kategoriler altında inceleyecek olursa, 130 soru içerisinde A1 den 9, A2 den 14, A3 den 87, B1 den 14, B2 den 2, C1 den 2, C2 den 2 soru bulunurken C3 den hiç soru bulunmadığı görülmektedir.

SONUÇ VE ÖNERİLER

Ortaya çıkan temel sonuç her üç sınavda da çok büyük bir oranda A3 kategorisinde soru bulunmasıdır. A3 kategorisi rutin işlemleri içerdiği için üç sınavında karakteristik olarak rutin işlemlerin yapıldığı, algoritmaların ve soru içeriğindeki metodların doğru kullanılmasını gerektiren sorulardan oluştuğu ortaya çıkmaktadır. Bu durum söz konusu sınavlarda yüksek seviyedeki zihinsel becerileri hedef alan kategorilerde (B ve C) soruların çok az olduğunu ya da hiç olmadığını göstermektedir. S1 de C kategorisinde hiç soru olmaması ve S2 de B ve C kategorilerinde, S3 de C de toplam 2 sorunun olması ilginç bir sonuçtur. Bu noktada; bilgiyi bir formdan başka bir forma dönüştürebilme yeteneğini, uygun metotları veya bilgiyi yeni durumlarda seçebilme ve uygulayabilme yeteneğini, doğrulamayı, değerlendirme ve yargılamayla birlikte karşılaştırma ve çıkarımlar yapabileme yeteneğini ölçen soruların incelenen sınavlarda çok az (ya da hiç) yer aldığı gözükmektedir. Bu ise bize matematik öğretmenlerinin mesleğe ilk atanmalarında ya da farklı lise türlerine geçiş atanmalarında dikkate alınan bilgi düzeyinin (incelenen üç sınav bazında) düşük seviyede kaldığını göstermektedir. Bu sonuç üzerinde düşünmeyi ve tartışmayı gerekli kılmaktadır. MT’de üst düzey zihinsel beceri gerektiren basamaklarındaki soruların sorulmasıyla sınava girenlerin daha derin düşünmeye ve öğrenmeye itilmesi amaçlanmaktadır. Burada yüksek seviye ile kastedilen daha zor demek değildir. MT, soruların zorluk seviyesinden ziyade aktivitenin doğasıyla ilgilenir (Smith & Wood, 2000). Bu sonuçlardan yola çıkarak aşağıdaki öneriler sunulabilir;

Mesleğe başlarken (ilk atama için) uygulanan ve mesleğe başladıktan sonra lise türleri arasındaki geçişi sağlayan sınavlardaki alan bilgisi sorularının -ileriki yıllarda yapılacak olanları ile birlikte- daha ayrıntılı analizi yapılarak elde edilen sonuçlar ilgili mercilere bir rapor ile bildirilmelidir.

MT ile ilgili yapılan çalışmaların çoğu lisans düzeyine uygun olduğu için MT’nin lisans düzeyindeki öğretimde ve matematik sınavlarında dikkate alınmasını teşvik etmek ve desteklemek yararlı olacaktır.

Üniversite hocalarının ve araştırmacıların MT’ye göre çok sayıda soru yazmasını ve bunların bir platformda paylaşılmasını sağlamak ve desteklemek alan bilgisinin yapılandırılmasını ve ölçümünü daha nitelikli hale getirmede yararlı olacaktır.

Farklı seviyelere, konulara ve sınavlara yönelik MT’yi içeren akademik araştırmaların artırılmasını sağlayacak destekler verilmelidir.

KAYNAKLAR

Bloom, B. S. (1956). Taxonomy of Educational Objectives; the classification of educational goals, By a committee of college and university examiners.

Kesgin, Ş. (2012). Matematik Öğretmen Adaylarının Soyut Matematik Dersindeki Bilgilerinin Math Taksonomi Çerçevesinde Analizi (Yüksek lisans tezi, Dokuz Eylül Üniversitesi, 2012).

MEB, (2010). Millî Eğitim Bakanlığına Bağlı Fen Liseleri Ve Sosyal Bilimler Liselerinin Öğretmenleri İle Güzel Sanatlar Ve Spor Liselerinin Beden Eğitimi, Müzik Ve Görsel Sanatlar/Resim Öğretmenlerinin Seçimi Ve Atamalarına Dair Yönetmelik. http://mevzuat.meb.gov.tr/html/27790_0.html

MEB, (2012). İnsan Kaynakları Genel Müdürlüğü, 2012 Fen, Sosyal Bilimler, Güzel Sanatlar Ve Spor Liseleri İle Her Türdeki Anadolu Liseleri Öğretmenlerini Seçme Sınavı. <http://www.meb.gov.tr/sinavlar/detay.asp?id=25&id2=0&id3=14>

ÖSYM, (2012). Öğretmenlik Alan Bilgisi Testi, Basın Duyurusu. <http://www.osym.gov.tr/belge/1-13857/basin-duyurusu-ogretmenlik-alan-bilgisi-testi-oabt-1012-.html>

ÖSYM, (2013). Kamu Personel Seçme Sınavı Öğretmenlik Alan Bilgisi Testi Matematik (Lise) Öğretmenliği. <http://www.osym.gov.tr/dosya/1-69708/h/matematik-lise.pdf>

ÖSYM, (2013). Kamu Personel Seçme Sınavı Öğretmenlik Alan Bilgisi Testi İlköğretim Matematik Öğretmenliği. <http://dokuman.osym.gov.tr/pdfdokuman/2013/kpss1/%c4%b0lk%c3%b6%c4%9fretim%20matematik.pdf>

Smith, G.H., Wood, L.N., Coupland, M., Stephenson, B., Crawford, K. & Ball, G. (1996). Constructing mathematical examinations to assess a range of knowledge and skills, *Int. J. Math. Educ. Sci. Technol.*, 27(1), 65-77.

Smith, G.H. & Wood, L.N. (2000). Assessment of learning in university mathematics. *Int. J. Math. Educ. Sci. Technol.*, 31(1), 125-132.

Uğurel, I., Morali, S. & Kesgin, Ş. (2012). OKS, SBS ve TIMSS Matematik Sorularının ‘Math Taksonomi’ Çerçevesinde Karşılaştırmalı Analizi, *Gaziantep Üniversitesi Sosyal Bilimler Dergisi*, 11(2), 426-444.

Wood, L.N. & Smith, G.H. (2002). Perceptions of difficulty, *Proceedings of 2nd International Conference on the Teaching of Mathematics*, (1-6 July), Hersonissos, Greece.

Wood, L.N., Smith, G.H., Petocz, P. & Reid, A. (2002). Correlation between student performance in linear algebra and categories of a taxonomy. In M. Boezi (Ed.), *2nd International Conference on the Teaching of Mathematics (At the Undergraduate Level)*, Crete, John Wiley.

BİÇİMLENDİRİCİ DEĞERLENDİRMENİN MATEMATİK BAŞARISINA VE HATIRLAMAYA ETKİSİ

EFFECT OF FORMATIVE ASSESSMENT ON MATHEMATICS SUCCESS AND RETENTION

Emine Gülen TEKİN
Marmara Üniversitesi
gulenusoy@gmail.com

Ahmet Şükrü ÖZDEMİR
Marmara Üniversitesi
aso23@hotmail.com

ÖZET: Bu araştırmada matematik eğitiminde biçimlendirici değerlendirme öğrencinin matematik başarısına ve hatırlamasına etkisini araştırmak amaçlanmıştır. Bu amaç doğrultusunda İstanbul ilinde bulunan bir ilköğretim okulunun 8. sınıf öğrencileri ile uygulama yapılmıştır. Uygulamada matematik başarı testi ve hatırlama testi veri toplama aracı olarak kullanılmıştır.

Araştırmada “ön-test son-test kontrol grubu” deneme modeli kullanılmıştır. 47 katılımcıdan oluşan araştırmada (deney grubu 24, kontrol grubu 23 öğrenci) deney grubuna, uygulamaya katılmak için gönüllü öğrenciler seçilmiştir. Veri toplama aracı olarak 7 açık uçlu sorudan oluşan başarı testi kullanılmıştır. Başarı testi öğrencilerin hazırbulunuşluk düzeylerini belirlemek için ön-test, uygulamanın etkisini belirlemek için son-test ve hatırlama düzeyini belirlemek için hatırlama testi olarak kullanılmıştır.

Araştırmada elde edilen veriler bağımlı örneklem t-testi, bağımsız örneklem t-testi ve Pearson korelasyonu analizleri yardımıyla yorumlanmıştır. Sonuçlara göre başlangıç düzeyleri arasında anlamlı farklılık bulunmayan iki gruptan birine uygulanan biçimlendirici değerlendirme öğrencinin matematik başarısı ve hatırlama düzeyine olumlu etki yaptığı kanısına ulaşılmıştır.

Anahtar sözcükler: biçimlendirici değerlendirme, geri bildirim, matematik başarısı, hatırlama

ABSTRACT: The purpose of this study is to investigate effects of formative assessment on students' success and retention in mathematics education. An intervention had been made with the 8th grade students of a middle school, in İstanbul. In that intervention, mathematics achievement test and retention test were used as data collection tools.

“Pre-test, post-test with control group” model is used as a model of study. In the research, 47 applicants (experiment group: 24 students, control group: 23 students) had been chosen to experiment group in order to attend the application. Mathematics achievement test was used, in turn, as pre-test to determine students' academic level, as post-test to investigate effects of intervention and last, as retention test to specify retention level.

Data analyzed with t-test statistical methods. Considering results of analyses, formative assessment's positive effects on mathematics success and retention on groups which have same academic level before intervention had seen.

Key words: formative assessment, feedback, mathematics success, retention

GİRİŞ

Değerlendirme konusu öğretmenler için her zaman karışık ve önemli bir konu olmuştur. Öğretmenler, öğrencilerin neyi anlayıp anlayamadıklarını, hatırlayıp hatırlayamadıklarını bugüne kadar geleneksel yöntemler ile açığa çıkarmışlardır. Öğretmenlerin kullandıkları değerlendirme testleri bazen içeriğin tümüyle taranmasına yeterli olamamaktadır (Kamphaus, 1991). Resnick'e göre (1987), öğretmenlerin kullandıkları geleneksel

değerlendirme testleri öğrencilerin bilişsel yeteneklerini dar bir alanda incelemekte ve onların edindikleri bilgileri günlük hayatlarında nasıl kullandıkları ile ilişkili olmamaktadır.

Öğrencilerin kültür farklılıklarının artması (Cushner; McClelland & Safford, 1996), öğrenme ihtiyaçlarının da farklılık göstermesine (Hallahan & Kaufman, 1997) ve öğrenme yöntemlerinin de farklılaşmasına neden olmaktadır (Dunn & Grigys, 1988). Öğrenme yöntemleri farklılaştıkça, öğrenmeyi ölçme ve değerlendirme araçları da farklılaşmaktadır.

ABD’deki, Ulusal Matematik Öğretmenleri Konseyi (National Council of Teachers of Mathematics [NCTM], 1989) yayınlamış olduğu standartlarda öğrencinin neyi yapıp yapamadığının yanında neyi bildiğini değerlendiren, matematik öğrenmesini destekleyen, yazılı, sözlü ve eylemsel olarak performansını açığa çıkaran çeşitli değerlendirme teknik ve araçların kullanılmasını önermektedir. Bu yüzden, öğrencilerin performanslarını değerlendirmek ve gelişimlerini takip etmek için geleneksel değerlendirme araç ve tekniklerinden farklı olarak alternatif değerlendirme tekniklerinin kullanılmasına ihtiyaç vardır (NCTM, 1989; 1995).

Gipps’e göre (1994a) değerlendirmenin biçimlendirici fonksiyonu; Öğretmenin öğrencileri değerlendirme süreci, ders işlenişinde karar vermede yardımcı olurken, öğrencilerin neyi ve nasıl öğrendiklerini, ne şekilde öğretim yapılması gerektiğine ilişkin bilgilerin elde edilmesini sağlamasıdır.

Biçimlendirici Değerlendirme

Scriven (1967), değerlendirmenin oynayabileceği iki rol önerdi. Bir tarafta, “müfredatın sürekli gelişiminde bir rol oynayabilir”(s.41); diğer tarafta ise, “Değerlendirme süreci, okul yönetiminin, değerlendirmenin ilk rolü uyarınca düzenlenerek tümüyle tamamlanmış müfredatın var olan alternatiflerden belirgin düzeyde daha gelişmiş olup olmadığına karar verebilmesine hizmet eder.”(s.41-42). Daha sonra Scriven, “biçimlendirici (formative)’ ve ‘düzey belirleyici (summative)’ değerlendirme terimlerinin, değerlendirmeyi bu rollere göre nitelendirmek amacıyla kullanılması” gerektiğini önermiştir. (s.43)

Benjamin Bloom (1969) iki yıl sonra aynı ayrımın öğrenci öğreniminin değerlendirilmesi için de uygulanmasını önerdi. Testin öğrencileri yargılama ve sınıflamada oynadığı geleneksel rolü doğruladı ama değerlendirme için başka bir rol olduğuna dikkat çekti:

“Biçimlendirici değerlendirme” öğretme ve öğrenme sürecinde her aşamada geri bildirim ve düzeltmeler sağlamak için kullanılır. “Biçimlendirici değerlendirme” ile bizim bahsettiğimiz, öğrenme sürecinde yardımcıları olarak öğretmen ve öğrenciler tarafından kullanılan kısa testler ile yapılan değerlendirmelerdir. Böyle testler değerlendirmenin yargılama ve sınıflama fonksiyonlarının parçası olarak notlandırılarak kullanılabilirken; biçimlendirici değerlendirmenin daha verimli kullanımını notlandırmadan ayrılıp esas olarak öğretmeye yardımcı olması için kullanılırsa görürüz. (s.48)

Bu erken dönem kullanımlarında açıkça, ‘*biçimlendirici*’ terimi değerlendirmenin bir özelliği olamıyor. Bloom’un (1969), biçimlendirici ve düzey belirleyici süreçler için aynı testlerin kullanılabileceğini, öte yandan, eğer testler notlandırmanın birer parçası olacaksa biçimlendirici kullanımın daha az verimli olacağını ileri sürüyor. Biçimlendirici değerlendirmelerin en kritik vasfı Scriven (1967) ve Bloom (1969)’a göre, bilginin değişim yapmak için kullanılmasıdır. Müfredat veya öğrenci başarısı değerlendirilsin, eğer bilgi, bu bilginin yokluğunda ne olacağı hakkında değişiklik yapmak için kullanılacaksa değerlendirme biçimlendiricidir.

Biçimlendirici değerlendirme; öğrencinin öğrenme hızı veya güçlükleri hissedildiği zaman, öğretim durumlarındaki yetersizlikler ve hataların düzeltilmesi için öğretim sırasında yapılan bir değerlendirmedir. Son olarak da düzey belirleyici değerlendirmedir. Hem öğretimin etkililiğini, hem de öğrencinin istedik davranışları kazanıp kazanmadığını ortaya koymak için yapılmaktadır (Ertürk).

Harlen ve diğerlerine (1992) göre öğretmen tarafından yapılan biçimlendirici değerlendirmelerin temel rolü, günlük elde edilen veriler bazında öğrenmeyi takip edip ve öğretim sürecinde verilen kararlar sağlamak olarak tanımlanmıştır (Harlen ve diğerleri, 1992). Öğretmen biçimlendirici değerlendirme için topladığı bilgiler ışığında sene sonunda öğrenci hakkında genel bir başarı değerlendirmesi yapar. Bu da öğretmenin değerlendirmesinin düzey belirleme fonksiyonunu oluşturur (Daugherty, 1996).

Black ve William (1998a), biçimlendirici değerlendirmenin sınıftaki akademik standartları yükseltip yükseltmediğine dair çok daha büyük bir havuzdan derlenerek oluşturulmuş 250 makale ve kitap bölümünün kapsamlı araştırma incelenmesini yaptılar. Biçimlendirici değerlendirmeyi güçlendirici çabaların, öğrencilerin test sonuçlarındaki ortalama gelişimlerin kıyaslanmasıyla ölçülen ve aynı testte tipik gruplar oluşturacak

aralıkların keşfedilmesine yol açan önemli öğrenim kazanımları ürettiği sonucuna vardılar. 0,4 ile 0,7 arasında değişen etki aralığında, biçimlendirici değerlendirme belirgin bir şekilde öğrenme güçlükleri olan öğrenciler ile birlikte düşük başarılı öğrencilere, diğer öğrencilere ettiğinden daha fazla yardım etmiştir. (Black and Wiliam, 1998b).

Biçimlendirici değerlendirme öğrenme sürecinde yer almalıdır. Ayrıca, öğrenmenin öğrenme üstüne inşası gibi biçimlendirici değerlendirme gerçekçi model üstüne inşa olmalıdır. Geometrik uzayda bir nokta gibi öğrenciyi değerlendirmek yerine, düzey belirleyici değerlendirmede olduğu gibi, öğrenciler bilginin belirli bir durumu olarak düşünülmelidir (Hunt, E., & Pellegrino, J. W, 2002).

Biçimlendirici Geri Bildirim

Biçimlendirici değerlendirmenin bir parçası olarak verilen geri bildirim, öğrencilerin arzu edilen hedefleri ve mevcut bilgi, anlayış ya da becerileri arasında oluşacak herhangi boşluğun farkında olmalarına yardımcı olur; hedeflerine ulaşmak için gerekenleri yapmalarına rehberlik eder (Ramaprasad, 1983; Sadler, 1989). Ödev ve testlerdeki en yardımsever geri bildirim tipi hatalara dair özel yorumlar getirir, gelişim hakkında özel tavsiyelerde bulunur ve öğrencilerin doğrudan sadece doğru cevabı vermeleri yerine dikkatlerini itinayla konuya odaklamalarını sağlar (Bangert-Drowns, Kulick, & Morgan, 1991; Elawar & Corno, 1985). Bu tip geri bildirimler düşük başarılı öğrencilere kısmen yardımcı olabilirler, çünkü öğrencilerin doğuştan geldiği varsayılan kabiliyet eksikliklerine bağlı düşük başarıya terk edilmesi yerine çaba sonucunda gelişebileceklerini vurguluyor. Biçimlendirici değerlendirme tüm çocukların yüksek seviyelerde öğrenebilmesi umudunu desteklemeye yardım ediyor ve öğrencilerin kabiliyet eksiklikleriyle zayıf performans sergilemesiyle şevklerinin kırılarak ileri öğrenmeye karşı isteksiz olmalarına dayanan döngüye karşı koyuyor (Ames, 1992; Vispoel & Austin, 1995).

Geri bildirim genellikle öğretmen kaynaklı olsa da, öğrenciler de öz değerlendirmeye biçimlendirici değerlendirmede önemli bir rol oynayabilirler. İki deneysel araştırma çalışması, öğrenme amaçlarını ve değerlendirme kriterlerini anlayan ve işlerine yansıtma imkânı olan öğrencilerin, olmayanlara göre daha büyük gelişme kaydettiğini gösterdi (Fontana & Fernandes, 1994; Frederiksen & White, 1997). Okuma yazma anlayışlarına göre kendini izleme stratejileri kullanımı öğretilmiş öğrenme engelleri olan öğrenciler de performans kazanımları gösterdi (McCurdy & Shapiro, 1992; Sawyer, Graham, & Harris, 1992).

Öğrenciye verilen geri değerlendirme sürecinin en önemli bölümünü oluşturmaktadır. Biçimlendirici değerlendirmenin öğrenmeye olumlu yönde etki yapabilmesi dönütün öğrenciye karşı etkili bir şekilde kullanılması ile mümkün olmaktadır. Ayrıca öğrenci-öğretmen iletişiminde değerlendirme kendini bu dönüt sayesinde göstermekte ve bunun etkili kullanılması ile değerlendirmenin amacına ulaşmasını sağlamaktadır (Türnüklü, 2003).

Geri bildirim anahtar bileşenleri şunlardır (Black, Harrison, Lee, Marshall ve William, 2005);

- Güncel seviyedeki verinin ölçülebilir davranıştan elde edilebilir olması.
- Bu davranışa ait verinin istenilen seviyeden olması.
- İki seviyeyi karşılaştırmak için bir mekanizma ve aralarındaki farkı ölçebilme.
- Farkı kapatmak için bilginin kullanılabilmesi için bir mekanizma.

Düzyer belirleyici değerlendirme yaklaşımlarında öğrenciye verilen tek geri bildirim sınav notu olduğundan, dönem ya da yıl içinde belirli aralıklarla yapılan sınavlardan elde edilen notlar öğrenciye bildirilir ve bu geri bildirim yargılayıcıdır. Biçimlendirici değerlendirme yaklaşımlarında ise geri bildirim, öğretmenin çalışma hakkındaki yorumu demektir ve öğrenim süreci devam ederken verilir. Bu da öğrencinin kendisini geliştirmesine yardımcı olur. Bu şekilde verilen geri bildirim öğrenciye ulaşması da kısa sürede olur. Fakat düzey belirleyici yaklaşımlarda sınav sonuçları ya da puanları öğrenciye haftalar sonra ulaşabilir (Tierney, 1991).

Biçimlendirici değerlendirme sayesinde öğrenciler neyi öğrenmekte ve neyi öğrenmemekte olduklarının farkında olabiliyorlar. Birinin kendi öğrenmesini kontrol etme yeteneği belki de biçimlendirici değerlendirmenin en önemli özelliğidir. Öğretmenlerin ulusal sınavlarda öğrenci başarısını arttırmaya yönelik kullandıkları tekniklerin öğrencilerin ileride bu bilgileri tekrar kullanmasına çok az etkisi olmaktadır. Uzun vadede önemli olan, “nasıl öğrendiğini öğrenme” yeteneğini kazanmaktır (Black, Harrison, Lee, Marshall ve William, 2005).

İyi bir geri bildirim özellikleri şu şekildedir (Jawah, Macfarlane-Dick, Matthew, Nicol, Ross ve Smith, 2004):

- Öz değerlendirme gelişmesine imkan sağlar.
- Öğretmen ve akran diyaloglarını öğrenme çerçevesinde cesaretlendirir.
- İyi performansın ne olduğunu daha açık hale getirir (amaçlar, kriterler, beklenen standartlar).
- Gösterilen performans ve istenilen performans arasındaki farkın kapanmasına olanak tanır.
- Öğrencilerin öğrenmeleri hakkında onlara iyi kalitede bilgi sağlar.
- Kendine güveni ve pozitif motivasyon hakkındaki düşünceleri kuvvetlendirir.
- Öğretmenlerin öğretilerini şekillendirmeleri için bilgi sağlar.

Biçimlendirici Değerlendirmenin Örnekleri

Biçimlendirici değerlendirme amacı öğrencilerin ne bildiğini ve ne bilmediğini anlamak olduğundan, öğretme ve öğrenmede duyarlı değişiklikler yapabilmek için testlerin ve ödevlerinin analizinde öğretmen gözlemi ve sınıf tartışması gibi tekniklerin çok önemli bir yeri vardır (Boston, 2002).

Black ve William (1998b) öğretmenleri, soru sormayı ve sınıf tartışmalarını öğrencilerin bilgilerini artırmak ve anlamalarını geliştirmek için kullanmaya teşvik etmektedirler. Ancak, öğretmenler soru sorarken basit ve bilgi içeren sorular yerine düşündürücü ve yansıtıcı sorular sormaya dikkat etmelidirler ve soru sorduktan sonra öğrenciye yeterli zaman vermelidirler. Herkesi kapsamaması açısından bazı stratejiler önermişlerdir:

- Öğrencileri bir soru veya konu hakkında çiftler veya küçük gruplar halinde tartışmaya davet edin. Daha sonra, düşüncelerini daha büyük gruplara göstermelerini isteyin (bazen düşün-eşleş-paylaş diye adlandırılır).
- Bir sorunun birçok cevabını gösterin ve öğrencilerden onları oylamalarını isteyin.
- Her öğrenciden bir cevap yazmasını isteyin ve daha sonra seçilenleri yüksek sesle sınıfta okutun.

Öğretmenler öğrencilerin anlamalarını aşağıdaki yollarla da değerlendirebilirler:

- Öğrencilere kelimeler veya kavramlarla ilgili anlamalarını dersten önce ve sonra yazdırın.
- Öğrencilerden, dersin, tartışmanın veya okumanın ana fikirlerini kendi cümleleri ile özetlemelerini isteyin.
- Öğrencilere ders sonunda birkaç problem veya soru verin ve bunların cevaplarını kontrol edin.
- Öğrenciler problem çözerken onlarla bireysel olarak veya gruplar halinde görüşme yapın.
- Sınıfta yazabilecekleri kısa bir kompozisyon verin (bu kişi veya bu olay neden tarihte bu zamanı temsil eder gibi).

Bu sınıf içi etkinliklere ek olarak, eğer öğretmenler öğrencilerin anlamalarının nerede olduğunu analiz edecek ve onlara performanslarından ziyade onları geliştirmek için bireye özel ve odaklanmış geri bildirim vereceklerse testler ve ödevler de biçimlendirici olarak kullanılabilirler (Boston, 2002). Black ve William (1998b), bu konuyla ilgili olarak aşağıdaki önermeleri yapmışlardır:

- Sık sık yapılan kısa testler, uzun aralıklarla yapılan uzun testlerden daha iyidir.
- Yeni öğrenme bir hafta içinde test edilmelidir.
- Test sorularını oluştururken dikkatli olun ve en iyilerini seçmek için dışarıdan kaynaklar tarayın ve diğer öğretmenlerle birlikte çalışın.

Eğer öğretmenler ve öğrenciler dosyadaki çalışmalarını yorumlayacak, büyümeyi gözlemleyecek ve pratik yapacaklarsa portfolyolar - öğrenci çalışmaları koleksiyonları - da biçimlendirici olarak kullanılabilirler (Duschl ve Gitomer, 1997).

Biçimlendirici Değerlendirme Neden Ciddiye Alınmalı?

Öğretmenlerin deneyimlerine ait araştırma sonuçları biçimlendirici değerlendirmenin sınıf çalışmasının güçlü bir özelliği olmadığını göstermektedir. İyi bir biçimlendirici değerlendirme uygulaması için öğretmenlerin sınıfta önemli değişiklikler yapmaları gerekir. Sınıfta yapılacak herhangi bir değişim, öğretmenin hem risk almasını hem de değişim süreci boyunca fazladan çalışmasını gerektirmez. Öğretmenler biçimlendirici değerlendirmenin gelişimini içeren değişimleri aşağıdaki nedenlerden ötürü önemli bulacaklardır (Black, Harrison, Lee, Marshall ve William, 2005):

- Değişimin öğrencilerin geleneksel testlerdeki notlarını yükselteceğine dair yeterli delil bulunmaktadır.
- Öğretmenlerin bu değişimi normal sınıf çalışmalarlarıyla başarılı bir şekilde birleştirebilecekleri uygun görülmüştür.
- Değişim sarf edilen eforun yeni bir dağıtımına yol açar: daha çok çalışmak değil, daha zekice çalışmak.
- Değişimler basamak basamak gerçekleştirilebilir. Riskli girişimler gereksizdir.
- Öğretmenler işlerinden daha çok zevk alacak ve işlerini daha tatmin edici bulacaktır çünkü değişimler onların profesyonel değerleriyle örtüşmektedir.
- Aynı zamanda, değişimin sonucu olarak öğrenciler derslerden zevk alacak, dersleri anlayacak ve öğrenimlerini daha çok kıymetlendireceklerdir.

Araştırmanın Amacı ve Önemi

Bu araştırmanın amacı matematik eğitiminde biçimlendirici değerlendirmenin öğrenci başarısına ve hatırlamasına etkisinin olup olmadığını araştırmaktır. Bu amaç doğrultusunda araştırmanın problemi ‘biçimlendirici değerlendirmenin matematik başarısına ve hatırlamaya etkisi nasıldır?’ şeklinde belirlenmiştir. Bu problem çerçevesinde şu sorulara yanıt aranmaktadır:

1. Deney ve kontrol grubu öğrencilerinin uygulama öncesi ve sonrası matematik başarıları arasında anlamlı bir fark var mıdır?
2. Deney grubu öğrencilerinin uygulama öncesi ve sonrası matematik başarıları arasında anlamlı bir fark var mıdır?
3. Kontrol grubu öğrencilerinin uygulama öncesi ve sonrası matematik başarıları arasında anlamlı bir fark var mıdır?
4. Deney ve kontrol grubu öğrencilerinin uygulama sonrası hatırlamalarında anlamlı bir fark var mıdır?

YÖNTEM

Araştırmanın Modeli

Bu çalışmada, araştırma modeli türü olan deneme modellerinden “öntest sontest kontrol gruplu” araştırma modeli kullanılmıştır.

Çalışma Grubu

Araştırmada tesadüfî veya seçkisiz olmayan örnekleme yöntemlerinden uygun/kazara örnekleme metodu kullanılmıştır. Uygun örnekleme yöntemine iki örnek olarak gönüllü katılımcıların kullanılması veya sadece orada olduğu için orada var olan katılımcıların kullanılması verilebilir. Soruları cevaplayan gönüllü katılımcılar genellikle gönülsüz olanlardan farklıdır. Çalışmaya daha motive olmuş veya daha ilgili olabilirler. Bütün ana kütle hem gönüllü hem de gönülsüz katılımcılardan oluştuğu için araştırmanın sonuçları tüm ana kütleyle genellenemez (Gay, Mills ve Airasian, 2006). Uygun örnekleme metodunun bu özelliği bu araştırmanın sınırlılıkları arasındadır.

Bu arařtırmada bulunan 24 gönüllü öğrenci arařtırmanın deney grubunu, 23 gönülsüz öğrenci ise arařtırmanın kontrol grubunu oluřturmuřtur. Bu öğrenciler uygulama okulunda bulunan 8. Sınıf öğrencilerden seçilmiřtir. Her iki gruba da müfredatin belirttiđi řekilde ders iřlenmiřtir. Deney grubunu ile çalıřmalar ders akıřını etkilememesi ve süre sınırlamasına bađlı kalmamak için ders dıřında yapılmaya çalıřılmıřtır.

Arařtırma Süreci

Bu arařtırmada, deney ve kontrol gruplarının kombinasyon ve permütasyon konusu hakkındaki bilgi düzeylerini belirlemek amacıyla ön-test; uygulama sonucundaki farklılıkları görmek için son-test uygulanmıřtır. Öğrencilerin konuyu hatırlayıp hatırlamadıklarını belirlemek için son-test uygulamasından 8 hafta sonra öğrencilere hatırlama testi olarak son-test tekrardan uygulanmıřtır. Seçilen her iki gruba da ön-test, son-test ve hatırlama testi uygulanmıř ancak hazırlanan çalıřma kađıtları sadece deney grubuna uygulanmıřtır.

Çalıřma kađıtları ve başarı testleri uzman görüşleri (bir öğretim üyesi, 2 uzman öğretmen) alınarak arařtırmacı tarafından hazırlanmıř ve MEB kitabında bulunan etkinliklerden yararlanılmıřtır.

Uygulama 5 hafta sürmüřtür ancak uygulama bittikten 8 hafta sonunda hatırlama testi ile birlikte süreç toplam 13 haftayı bulmuřtur. Uygulamaya olasılık çeřitleri alt öğrenme alanın iřlenmesi ile bařlanmıř ve sırasıyla olay çeřitleri ve olası durumları belirleme alt öğrenme alanları iřlenmiřtir.

Uygulamaya bařlamadan önce; öğrencilere uygulamanın amacından, sürecinden ve neden yapıldığında bahsedilmiř ve gönüllü katılımcılar belirlenmiřtir. Uygulama esnasında ders içi olduđu kadar ders dıřı faaliyetlerde bulunduđu için okula ulařım problemi olmayan, velilerinin okul dıřında da kalmasına izin veren ve bu ders dıřı faaliyetlere kendisi de kalmaya gönüllü olan öğrenciler seçilmiřtir. Bu öğrencilerin ailelerinden sözlü olarak izin alınmıřtır. Öğrencilerin kombinasyon ve permütasyon konusunu öğrenirken çeřitli zorluklar göz önüne alınarak uygulamanın bu konular iřlenirken yapılması arařtırmacı tarafından uygun görülmüřtür. Kombinasyon ve permütasyon konusuna bařlamadan önce hem üniteye yer aldıđı için hem de bu konulara giriř niteliğinde olduđu için uygulamaya olasılık çeřitleri konusu ile bařlanmıřtır. Konu iřlenirken matematik başarı testi ön-test olarak uygulanmıřtır.

Olay çeřitleri ve olası durumları belirleme alt öğrenme alanları iřlenirken öğrencilere çalıřma kađıtları dađıtılmıřtır. Çalıřma kađıtlarını öğrenciler doldurduktan sonra uygulamacı tarafından toplanan çalıřma kađıtlarına öğrencilerin cevaplarına göre geri bildirimler verilmiřtir. Geri bildirimlere göre tekrar öğrencilerden çalıřma kađıtlarını doldurmaları istenmiřtir. İkinci defa toplanan çalıřma kađıtlarında yer alan cevaplara göre ihtiyacı olan öğrencilere ihtiyaçları dođrultusunda ders dıřında (öğrencinin uygun olmasına göre öğle yemek arasında veya okul çıkıřında) bire-bir veya grup halinde çalıřılmıřtır. Bu öğrencilere diđer öğrencilere verilmeyen çalıřma kađıtları veya testler verilmiřtir. Arařtırmacı bazen çalıřmalara rehberlik etmiř bazen de sadece gözetmenlik etmiřtir.

Uygulama sonucunda öğrencilere son-test uygulanmıřtır. Bu uygulamadan 8 hafta sonra ise hatırlama testi öğrencilerin hatırlama düzeylerini ölçmek amacıyla uygulanmıřtır.

BULGULAR

Çalıřmada yer alan problemler nicel analizler sonucu elde edilen verilerle birlikte tablolar halinde anlatılmaktadır. Veriler normal dađılım gösterdiđi için bađımlı örneklem t-testi ve bađımsız örneklem t-testi yöntemleri analizlerde kullanılmıřtır. Grupların başarıları arasındaki iliřkiyi ve yönünü belirlemek için ise Pearson korelasyon katsayısı hesaplanmıřtır

Gruplar Arası Arařtırma Öncesi ve Sonrası Farklılıklar

Tablo1’de arařtırmaya bařlamadan önce ve tablo 2’de arařtırmadan sonra deney ve kontrol gruplarının matematik başarı testi sonucunda elde edilen sonuçları yer almaktadır. Sonuçlar bađımsız örneklem t-testi analiz yöntemiyle elde edilmiřtir.

Tablo 1. Grupların Ön-Test Sonuçları

N	\bar{X}	ss	t	p
---	-----------	----	---	---

Deney Grubu	24	41,14	14,109	1,101	0,281
Kontrol Grubu	23	35,85	10,463		

Tablo 1’de yer alan sonuçlara göre uygulamaya başlamadan önce yapılan başarı testi sonuçlarına göre deney grubu daha yüksek ortalamaya sahip olmasına rağmen aradaki farklılık manidar değildir ($p=0,28>0,05$).

Tablo 2 incelendiğinde uygulamadan sonra yapılan başarı testi sonuçları görülmektedir. Bu sonuçlardan, deney grubunun kontrol grubuna göre oldukça yüksek ortalamaya sahip olduğu ve aradaki bu farklılığın anlamlı olduğu ($p=0,00<0,05$) fark edilmektedir.

Tablo 2. Grupların Son-Test Sonuçları

	N	\bar{X}	ss	t	p
Deney Grubu	24	74,43	17,814	4,658	0,000
Kontrol Grubu	23	47,54	11,148		

Deney Grubunda Araştırma Öncesi ve Sonrası Farklılıklar

Tablo 3, deney grubunun araştırmaya başlamadan önce ve araştırma sonrasındaki matematik başarı testi sonuçlarını içermektedir. Sonuçlar bağımlı örneklem t-testi analizleri ile elde edilmiştir. Öğrencilerin başarıları arasındaki ilişkiyi ve yönünü belirlemek için Pearson korelasyon katsayısı hesaplanmıştır.

Tablo 3. Deney Grubunun Ön-Test ve Son-Test Sonuçları

	N	\bar{X}	ss	t	p	r
Deney Grubu (Ön-Test)	24	41,14	14,109	-8,641	0,000	0,614
Deney Grubu (Son-Test)	24	74,43	17,814			

Tablo 3’e göre deney grubunun başarı ortalaması yükselmiştir. Deney grubunun ön-test ve son-test başarıları arasında anlamlı bir farklılık ($p=0,00<0,05$) vardır. Ön-test ve son-test sonuçlarının aritmetik ortalamaları incelenecek olursa son-test ortalamasının yüksek olduğu görülmektedir. Korelasyon sayısının verdiği sonuca göre ise pozitif yönde orta seviyede doğrusal korelasyon vardır. Bu durumda ön-test notu yüksek olan öğrencinin son-test notun da yüksek olduğu görülmektedir.

Kontrol Grubunda Araştırma Öncesi ve Sonrası Farklılıklar

Tablo 4’te kontrol grubunun araştırmaya başlamadan önce ve araştırma sonrasındaki matematik başarı testi sonuçları yer almaktadır. Sonuçlar bağımlı örneklem t-testi analizleri ile elde edilmiştir. Öğrencilerin başarıları arasındaki ilişkiyi ve yönünü belirlemek için Pearson korelasyon katsayısı hesaplanmıştır.

Tablo-4 incelendiğinde görülmektedir ki; kontrol grubunun ön-test ve son-test notları arasında anlamlı farklılık ($p=0,00<0,05$) vardır. Ancak, aritmetik ortalamalar incelenecek olursa kontrol grubunun son-test ortalamasının deney grubunun son-test ortalamasından düşük olduğu görülmektedir. Korelasyon katsayısı ise pozitif doğrusal yüksek korelasyon olduğu hakkında bilgi vermektedir. Bu korelasyon katsayısı, ön-test başarı testinden yüksek alan öğrencinin son-test başarı testinde de yüksek aldığına işaret etmektedir.

Tablo 4. Kontrol Grubunun Ön-Test ve Son-Test Sonuçları

	N	\bar{X}	ss	t	p	r
Kontrol Grubu (Ön-Test)	23	35,85	10,463			
				-5,622	0,000	0,761
Kontrol Grubu (Son-Test)	23	47,54	11,148			

Gruplar Arası Araştırma Sonrası Hatırlama Düzeyleri

Biçimlendirici değerlendirmenin hatırlamaya olan etkisini araştırma amacıyla son-test uygulandıktan 8 hafta sonra her iki gruba da uygulanan hatırlama testi ile ilgili analiz sonuçları tablo5, 6 ve 7'de verilmiştir. Deney grubunda 8 hafta sonunda bilgide kalıcılık yani hatırlama olup olmadığını ortaya çıkarmak için son-test ve hatırlama testi sonuçlarına bağımlı örneklem t-testi ve Pearson korelasyonu yapılmıştır.

Tablo 5 incelendiğinde deney grubunun son-test ile hatırlama testi notları arasında manidar bir farklılık olmadığı ($p=0,07>0,05$) görülmektedir. Hatırlama testinin ortalamasının daha düşük olmasına rağmen son-test notları ile hatırlama testi notları arasında anlamlı farklılık olmadığı için deney grubunda hatırlama olduğu anlaşılmaktadır. Bu hatırlamanın biçimlendirici değerlendirmeden kaynaklandığı söylenebilir. Pozitif yönlü yüksek korelasyon belirten Pearson korelasyon katsayısı ile son-test notu yüksek olan öğrencinin hatırlama testinden daha yüksek sonuçlar aldığı anlaşılmaktadır.

Kontrol grubunda 8 hafta sonunda hatırlama olup olmadığını ortaya çıkarmak için son-test ve hatırlama testi sonuçlarına bağımlı örneklem t-testi ve Pearson korelasyonu yapılmıştır.

Tablo 5. Deney Grubunun Son-Test ve Hatırlama Testi Sonuçları

	N	\bar{X}	ss	T	p	r
Deney Grubu (Son-Test)	24	74,43	17,814			
				2,000	0,067	0,863
Deney Grubu (Hatırlama Testi)	24	69,43	17,917			

Tablo 6'da yer alan sonuçlara göre kontrol grubunun son-test ile hatırlama testi notları arasında manidar bir farklılık olduğu ($p=0,00<0,05$) görülmektedir. Hatırlama testinin ortalamasının daha düşük olması ve son-test ile hatırlama testi notları arasında manidar farklılık bulunması öğrencilerin konuyu unutmaya başladıklarının göstergesidir. Pozitif yönlü yüksek korelasyon belirten Pearson korelasyon katsayısı ile son-test notu yüksek olan öğrencinin hatırlama testinden daha yüksek sonuçlar aldığı anlaşılmaktadır.

Tablo 6. Kontrol Grubunun Son-Test ve Hatırlama Testi Sonuçları

	N	\bar{X}	ss	t	p	r
Kontrol Grubu (Son-Test)	23	47,54	11,148			
				5,089	0,000	0,799
Kontrol Grubu (Hatırlama Testi)	23	38,08	8,995			

Deney grubu ile kontrol gruplarının hatırlama testi sonuçlarını karşılaştırmak için yapılan bağımsız örneklem t-testi analiz sonuçları tablo 7’de yer almaktadır.

Tablo 7. Deney ve Kontrol Gruplarının Hatırlama Testi Sonuçları

	N	\bar{X}	Ss	t	p
Deney Grubu	24	69,43	17,917	5,674	0,000
Kontrol Grubu	23	38,08	8,995		

Tablo 7 incelendiğinde kontrol grubunun hatırlama testi sonuçlarının, deney grubu hatırlama testi sonuçlarına göre bir hayli düşük olduğu fark edilmektedir. Bu farklılığın 0,05 önem seviyesine anlamlı olduğu ($p=0,00<0,05$) görülmektedir. Bu farkın biçimlendirici değerlendirmenin etkisinden kaynaklandığı söylenebilir.

SONUÇ

Uygulama sonrasında deney ve kontrol grubu öğrencilerinin matematik başarıları arasında farklılık görülmüştür. Uygulamaya başlamadan önce elde edilen veriler, grupların matematik başarıları arasında farklılık bulunmadığını göstermekteydi. Ancak, deney ve kontrol gruplarının ön-test ve son-test analizleri ayrı ayrı yapıldığında her grubun işlenecek olan konu başlamadan ve konu bittikten sonra yapılan testlerdeki sonuçlarında da anlamlı farklılık görülmüştür. Bu durum da deney ve kontrol grubu öğrencilerin son-test verileri arasında bulunan anlamlı farklılık biçimlendirici değerlendirmenin etkisinin sonucu olarak yorumlanabilir. Kontrol grubunun ön-test ve son-test verilerindeki farklılığın nedeni öğrencilerin konuyu çok yeni işlemiş olmasından kaynaklanabilir. Bu sonuçlar Özçelik’in (1992:196) belirttiği dönüt ve düzeltme işlemlerinden etkili bir şekilde yararlanılması halinde, öğrenmeye ayrılan zamanın etkin öğrenme çabasıyla geçen kısmı artmakta ve artan bu zamanda daha çok öğrenilmesi istenilen davranışın denenmesi sağlanmış olmaktadır. Öğretme-öğrenmeye ayrılan zaman ve öteki kaynakların kullanımındaki bu değişme, öğrencilerin öğrenme hızlarını artırmaktadır. Öğrenmeye ayrılan belli bir süredeki öğrenme hızı artınca bu süre içindeki öğrenmenin verimi de artmış olmaktadır düşüncelerle örtüşmektedir.

Uygulamanın öğrenciler üzerindeki hatırlamasında etkisine bakmak için uygulama bittikten 8 hafta sonra her iki gruba da hatırlama testi olarak matematik başarı testi uygulanmıştır. Öğrencilerin hatırlamalarına etkisinin olabileceği de göz ardı edilmemelidir. Kontrol grubunun hatırlama testi verileri ise öğrencilerin konuyu unutmaya başladığını göstermektedir. Çünkü kontrol grubunun son-test ve hatırlama testi verileri arasında anlamlı derecede farklılık vardır ve hatırlama testi ortalamaları daha düşüktür. Buradan da son-test ve hatırlama testi sorularının aynı olmasının etkisinin çok fazla olmadığı sonucuna varılabilir. Çünkü araştırmaya katılan her öğrenci aynı başarı testini ve hatırlama testini almıştır. Hatırlama sonuçlarına biçimlendirici değerlendirmenin yadsınamaz etkisi olduğu söylenebilir. Ayrıca, deney ve kontrol grubunun hatırlama verilerinin analizi ise bu iki grup arasında anlamlı derecede farklılık olduğunu göstermektedir. Deney grubunun hatırlama notları ortalaması, kontrol grubundan oldukça yüksektir.

Biçimlendirici değerlendirme öğretmenler için biraz zaman alıcı (hazırlama açısından) ve emek isteyen (geri bildirim ve ders dışı çalışma saatleri açısından) bir uygulama olsa da derslerde bütün konularda kullanılabilir.

Biçimlendirici değerlendirmede en önemli unsurlardan bir olan geri bildirim vermeye öğretmenler özen gösterebilirler ve geri bildirim anında ve açık bir şekilde verebilirler.

Öğretmenler, mümkün olduğunca çok uygulama hazırlayıp öğrencinin derste aktif olmasını ve konuyu iyice pekiştirmesini sağlayabilirler.

Müfredatın tanıdığı süre çerçevesinde konuların işleniş biçimlendirici değerlendirmenin tam olarak uygulanmasına olanak sağlamamasından dolayı, öğretmenler okul idaresi ile ortak çalışarak belli günlerde ders dışı çalışma etkinlikleri uygulayabilirler. Bu saatlerde geri bildirimler sayesinde öğrenme gücünü olan veya konuyu tam olarak anlayamayan öğrencilere daha fazla yardımcı olunabilir.

Öğretmenler öğrencilerin biçimlendirici değerlendirme uygulaması kapsamında hazırlanan çalışma kağıtlarına verdikleri cevaplara göre dersi şekillendirebilirler. Bütün sınıfa daha az anlaşılın konuya daha fazla zaman ayırıp, sınıfa iyi anlaşılın konuya daha az zaman ayırarak zamandan tasarruf yapılabilir.

Öğretmenler, öğrencilerin cevaplarına göre kendi öz eleştirilerini de yapabilirler. Sınıfın çoğunluğunun anlamada zorlandığı bir konuyu uygulanan çalışma kağıtları, düşünce kağıtları veya ara testler yardımıyla belirleyip öğretim metodunu değiştirebilirler.

Biçimlendirici değerlendirme öğretmenlerin, sınıfın veya öğrencilerin bir konuda zorluk yaşadığını sınav tarihi gelmeden çok daha önce tespit etmelerine yarar sağlayıp, öğrencilerin konuyu daha iyi anlamaları için öğretmenlerin erken müdahale etmelerine yardımcı olabilir.

Biçimlendirici değerlendirme, öğrencilerin konuyu hatırlamalarını olumlu yönde etkilediği için öğrencilerin öğretim yılı sonunda yapılan seviye belirme sınavlarında (SBS) daha başarılı olmalarını sağlayabilir.

KAYNAKLAR

- Ames, C. (1992). Classrooms: Goals, structures, and student motivation. *Journal of Educational Psychology*, 84 (3): 261-271.
- Bangert-Drowns, R.L., Kulick, J.A., ve Morgan, M.T. (1991). The instructional effect of feedback in test-like events. *Review of Educational Research*, 61 (2): 213-238
- Black, P., ve William, D. (1998a). Assessment and classroom learning. *Assessment in Education*, 5 (1): 7-74.
- Black, P., Harrison, C., Lee, C., Marshall, B., ve William, D. (2005) *Assessment for Learning "Putting it into practice"*. Berkshire: Open University Press.
- Black, P., ve William, D. (1998b). Inside the black box: Raising standards through classroom assessment. *Phi Delta Kappan*, 80 (2):139-148. (<http://www.pdkintl.org/kappan/kbla9810.htm>)
- Bloom, B. S. (1969). *Some theoretical issues relating to educational evaluation*. In R. W. Tyler (Ed.), *Educational evaluation: New roles, new means*. Chicago, IL: University of Chicago Press. National Society for the Study of Education Year-book, Vol. 68, Part 2, pp. 26-50.
- Boston, C. (2002). The Concept of Formative Assessment. *Practical Assessment, Research & Evaluation*, 8(9). <http://Pareonline.net/getvn.asp?v=8&n=9> (30 Nisan 2010).
- Cushner, K. McClelland, A., ve Safford, P. (1996). *Human diversity in education*. New York: McGraw-Hill.
- Daugherty, R. (1996). In search of teacher assessment- its place in the national curriculum assessment system of England and Wales. *The curriculum journal*, 7 (2), 137-152.
- Dunn, R., ve Griggs, S. (1988). *Learning Styles: Quiet revolution in American secondary schools*. Reston, VA: National Association of Secondary School Principals.
- Duschl, R.D., ve Gitomer, D.H. (1997). Strategies and challenges to change the focus of assessment and instruction in science classrooms. *Educational Assessment*, 4 (1): 37-73.
- Elawar, M.C., ve Corno, L. (1985). A factorial experiment in teachers' written feedback on student homework: Changing teacher behaviour a little rather than a lot. *Journal of Educational Psychology*, 77 (2): 162-173.
- Ertürk. <http://yayim.meb.gov.tr/dergiler/medergi/19.htm>. Web adresinden 16.05.2010 tarihinde alınmıştır.
- Fontana, D., ve Fernandes, M. (1994). Improvements in mathematics performance as a consequence of self-assessment in Portuguese primary school pupils. *British Journal of Educational Psychology*, 64 (3): 407-417.
- Frederiksen, J.R., ve White, B.J. (1997). Reflective assessment of students' research within an inquiry-based middle school science curriculum. Paper presented at the annual meeting of the American Educational Research Association, Chicago, IL.
- Gay L.R., Mills, G.E., ve Airasian, P. (2006) *Educational Research* (8. Baskı). Ohio: Pearson.
- Gipps, C.(1994a). *Beyond testing*. London: The Farmer Press.
- Hallahan, D., ve Kaufman, J. (1997). *Exceptional children: An introduction to special education*. Boston, MA: Allyn & Bacon.
- Harlen, W. Gipps, C., Broadfoot, P., ve Nuttall, D. (1992). Assessment and the improvement of education. *The curriculum journal*, 3(3): 215-230.
- Hunt, E., ve Pellegrino, J. W. (2002). *Issues, Examples, and Challenges in Formative Assessment*. Applying the science of learning to university teaching and beyond, 73-85.
- Jawah, C., Macfarlane-Dick, D., Matthew, B., Nicol, D., Ross, D., and Smith, B. (2004). Enhancing Student Learning Through Formative Feedback. *The Higher Education Academy Generic Centre*.

- Kamphaus, R.W. (1991). *Authentic assessment and content validity*. *School Psychology Quarterly*, 6, pp. 300–304.
- McCurdy, B.L., ve Shapiro, E.S. (1992). A comparison of teacher monitoring, peer monitoring, and self-monitoring with curriculum-based measurement in reading among students with learning disabilities. *Journal of Special Education*, 26 (2): 162-180.
- NCTM, 1989. *Curriculum and Evaluation Standards for School Mathematics*. (Available online document). <http://standards.nctm.org>.
- NCTM, 1995. *Assessment Standard for School Mathematics*, (Available online document). <http://standards.nctm.org>
- Özçelik, D. A. (1992). *Eğitim Programları ve Öğretim*. Ankara: ÖSYM Yayınları.
- Ramaprasad, A. (1983). On the definition of feedback. *Behavioral Science*, 28 (1): 4-13.
- Resnick, L.B. (1987). *Education and learning to think*. Washington, D.C.: National Academy
- Sadler, D.R. (1989). Formative assessment and the design of instructional systems. *Instructional Science*, 18 (2): 119-144.
- Sawyer, R. J., Graham, S., and Harris, K.R. (1992). Direct teaching, strategy instruction, and strategy instruction with explicit self-regulation: Effects on the composition skills and self-efficacy of students with learning disabilities. *Journal of Educational Psychology*, 84 (3): 340-352.
- Scriven, M. (1967). *The methodology of evaluation*. In R.W. Tyler, R.M. Gagné, & M. Scriven (Eds.), *Perspectives of curriculum evaluation*. Chicago, IL: Rand McNally. Vol. 1, pp. 39–83.
- Tierney, J. R. (1991). *Portfolio Assessment In The Reading-Writing Classroom*. Norwood, MA: Christopher-Gordon Publisher.
- Türnüklü, E. B. (2003). Türkiye ve İngiltere'deki Matematik Öğretmenlerinin Değerlendirme Biçimleri. *Hacettepe Üniversitesi Eğitim Fakültesi Dergisi* 24: 108-118.
- Vispoel, W.P., ve Austin, J.R. (1995). Success and failure in junior high school: A critical incident approach to understanding students' attributional beliefs. *American Educational Research Journal*, 32 (2): 377-412.

THE OPINIONS OF TEACHER CANDIDATES ABOUT THEIR TEACHER TRAINING COURSES

Gamze YAYLA
Cumhuriyet University
gamze_yyl@hotmail.com

Handan DEMİRCİOĞLU
Cumhuriyet University
handandemircioglu@gmail.com

ABSTRACT: This study was aimed to determine opinions of teacher candidates about their teacher training courses. Research sample consisted of 222 senior, who studied Science Education (n=170) and Mathematics Education (n=52) Departments. The data collected by asking courses that teacher candidates think they will contribute to the teaching profession and think they should be in teacher training program. Teacher candidates' answers were analyzed by using content analysis. After content analysis, courses are considered that they do not contribute to the teaching profession were examined under four categories which are field, field training, liberal education, pedagogical knowledge. Also, courses are considered that should be in teacher education were examined under six categories that are art, personal development, sport, technology, field/ field training, foreign language. In the conclusion, it was seen teacher candidates in both departments want to learn basic concepts that they will use when they are teacher in their field.

Key words: teacher training courses, science teacher candidates, mathematics teacher candidates

INTRODUCTION

Constantly changing and evolving nature of science, innovations in knowledge and communication technology brings along. Developing technology with the growing needs of individuals also requires the exchange of qualities expected of individuals. Therefore, the ability of individuals also varies expected. These skills should be given with systematic and purposeful education. The success of an education system depends on the quality and quantity of teachers who will operate the system (Arı, 2010). In the development of the country, for the growing of skilled manpower, in ensuring peace and security in society, socialization of individuals and social life in preparing, the society's cultural values transferring to the younger generation plays a key role in teachers (Sahin et al., 2013). Thus, the changing needs of society, and changes in technology and developments in the subject area, training programs and teacher training system also makes it inevitable constant revision and renewal (Aksu, 2005). Because teacher education, in general, the basic elements of human breeding scheme and is decisive (Bastürk, 2011). As teachers enable to create a positive impact on students, to give them the necessary information, and to make positive contributions to personality, these teachers need to teacher training programs that are well structured and will develop the teachers themselves (Sahin et al., 2013).

History of education in Turkey, many teacher education models has been tried and implemented (Arı, 2010). On the grounds of train being away from necessary qualifications teachers in terms of topics, content and completeness features of the courses in teacher education programs of Education Faculty, were required the setup changes or recalculations in the system (YOK, 1998). The solution of problems and needs in teacher training in order to eliminate, which started in 1994 and completed in 1998, YOK / World Bank within the framework of Pre-Service Teacher Education Project was the restructuring of the Faculty of Education (Yavuzer et al., 2006). In the light of these and similar reasons, the teacher training programs are constantly updated. As result of this the courses in the program and the content of this course, are expected to be held by gaining qualifications prescribed to teachers (Sisman, 2009). Teacher as the positions facilitator, guiding, sharing with students the responsibility and excitement of access to scientific knowledge, and a guide also directs the research process in the classroom e.g. must be cultivated to win these skills (MEB, 2013). Therefore, teacher education programs that will save these skills are seen to be a subject of many studies.

Bastürk (2011) asked them to evaluate the teaching-learning process in faculties of education from mathematics teacher candidates. Teacher candidates stated that found more theory than the application of courses and their content it was uncertain. Arı (2010) have taken their opinions related to their level of knowledge and teacher candidates' skills won related to primary school curriculum in the education faculties, and concluded that teacher candidates graduated from without win this required skills. Inal and Buyukyavuz (2013) taken their views for the professional development of English teacher candidates and undergraduate education, and

ultimately emphasized enough that the duration of internship, but the content was insufficient. Celik and Arıkan (2012) a qualitative work has been done about English teacher candidates how much prepared for foreign language teaching in to primary schools and has been stressed the weakest aspects of the program failure to prepare teachers in real classroom environment. Hismanoglu (2012) also have studied English teacher candidates teacher education programs and reached results about the program that appropriate to teacher candidates' interests and needs, which provide a permanent learning, as appropriate to the level of development. Akbayır and Tas (2009) For mathematics education and teacher training in Turkey received the opinions of teacher candidates, and as a result of the data obtained through surveys, internship is successful and they are growing aware of the high school curriculum of teacher candidates were seen. Analyzing the relevant literature, it is seen that the majority of work for the program aimed at overall appearance opinions. Existing teacher training programs through the eyes of prospective teachers and teachers should be evaluated and have been made about the overall assessment.

Bulca et al. (2009) in the study were examined physical education teachers' opinions on the adequacy of teacher training programs. As a result of the study, teachers have found sufficient liberal education courses such as computer English and history and most of the pedagogical knowledge courses in terms of the content of professional experience. Yavuzer et al. (2006) have asked for evaluation courses in program to determine classroom teaching graduates the level of benefit from the teacher training program. Teacher candidates unable to take advantage of mainly science courses from Field Courses, foreign language from liberal education courses are determined. Sahin et al. (2013) asked them to evaluate of pre-school teacher candidates courses in the current program. Teacher candidates have been suggested in the method and content of the courses. Ozkan and Sahbaz (2011) examined Turkish teacher candidates for their opinions on the functionality of Field Courses. In conclusion, they were identified missing such as vocational content is not given and too many details. In these studies, it is seen that investigating teacher training courses in the program, the courses listed and the opinions and recommendations which have been asked. Among these studies, it was not found studies examined courses in teacher training programs in the science and math fields.

In this context, the aim of this study was to determine opinions of science and mathematics teacher candidates on undergraduate courses in teacher training program. Starting from this idea, sub-problems of the research are as follows:

1. Which are the courses Science Teacher Candidates and Mathematics Teacher Candidates think that they will not contribute to teaching profession, even though they are in their teacher training program?
2. Which are the courses Science Teacher Candidates and Mathematics Teacher Candidates think that they should be in the teaching training program?

METHODS

In this study was used survey method. The most important feature of this research model is the definition an existing event or situation as it exists (Cepni, 2012). The main purpose is to observe without getting up to change. That is, this research approach aims to describe and define as it exists in the past or currently existing situation (Karasar, 2013).

Participants

Purposive sampling was used in sample selection. Purposive sampling is the most appropriate section of the research questions of the universe means to make a section of observation (Sencer, 1989). Thus, teacher candidates were selected last year students in order to evaluate their teacher training program. Research sample consisted of 222 senior, who studied Science Education (n=170) and Mathematic Education (n=52) Departments.

Data Collection Instruments and Data Analysis

The data collected by asking: Which are courses do you think that they will not contribute to teaching profession, even though they are in your teacher training program? Which are courses do you think that they should be in your teacher training program? Teacher candidates' answers were analyzed by using content analysis.

FINDINGS AND DISCUSSION

Findings Related to the First Sub-Problem of the Research

The teacher candidates were asked to evaluate teacher training program and were asked to indicate courses do not contribute to the teaching profession. Teacher candidates' answers on the basis of department analyzed separately, the following table has been created as a result of content analysis. Determination of the category in the content analysis, we were utilized the category of YOK which used to evaluate courses in the undergraduate program (Table 1).

Table 1. Courses will not Contribute on Teaching Profession

Science Teacher Candidates				Mathematics Teacher Candidates		
Category	Courses	f	%	Courses	f	%
Field	Genetics and Biotechnology (1), Astronomy (29), Analytical Chemistry (24), Introduction to Modern Physics (18), Earth Science (26), General Physics (2), General Chemistry (5), Human Anatomy and Physiology (26) Evolution (5), Statistics (16), Organic Chemistry(6)	158	44,5	Topology (22), Functional Analysis (13), Real Analysis (10), Numerical Analysis (16), Abstract Mathematics (1) Abstract algebra (8), Complex Variable Functions (2), Linear Algebra (4), Analysis (2), Differential Equations (2), Partial Differential Difeftansiyel Equations (2), Physics (6)	88	49,7
Field Training	Special Topics in Physics (18), Special Topics in Chemistry (12), Special Topics in Biology (3), Science Teaching Laboratory Practice (4) Nature of Science and History of Science (26)	63	17,7	Subject Area Textbook Review (8), Research Project in Field Education (1) History of Science (6)	15	8,5
Liberal Education	Scientific Research Methods (4), Service Learning Course (7), Atatürk's Principles and History (18th), Foreign Language-Eng. (14), Turkish (7) Computers (5), Elective Courses (37), History of Turkish Education (13)	105	29,6	Geometry-elective (2), Applied Mathematics- elective (1), Basic Concepts on Mathematics-elective (1), Elective Courses (7), Basic Computer Sciences (1), Computer Programming (6), Foreign Language (2), Atatürk principles and History of Revolution (2), Sevice Learning Course-choice (6), Scientific Research Methods-elective (3), Health Information and First Aid (24), Democracy and Human Rights (6)	61	34,5
Pedagogical Knowledge	Introduction to Educational Sciences (3), Teaching Principles and Methods (1), Educational Psychology (1), The Turkish Education System and School Management (13), Guidance (4), Special Education (4), Instructional Technology and Material Design (2) , Science and Technology Program and Planning (1)	29	8,2	Instructional Technology and Material Design (3) Introduction to Educational Sciences (1), Program Development and Training (5), the Turkish Education System and School Management (1), School Experience (3)	13	7,3

In Table 1, it is observed that both science teachers (44.5%) and mathematics teachers (49.7%) think will not contribute to the teaching profession field category more than others. It can said that Science teacher candidates not deems necessary in terms of the teaching profession field courses such as Astronomy (29), Analytical Chemistry (24), Earth Science (26), Human Anatomy and Physiology (26). Also, Mathematics teacher candidates not deem necessary in terms of teaching profession field courses such as Topology (22), Functional Analysis (13), Numerical Analysis (16). Özkan and Sahbaz' (2012) studies examine the opinions of prospective teachers for the courses, and ultimately most of the courses' content has said they thought it was too much detail. In Table 1, it is observed that there are liberal education courses that they think will not contribute to the teaching profession. A liberal education is a system or course of education suitable for the cultivation of a free human being. Both science teacher candidates and mathematics teacher candidates find it not necessary to be said courses such as Scientific Research Methods, Service Learning Course, Atatürk's Principles and History, Foreign Language-Eng., Computers, Elective Courses for the teaching profession.

Examining pedagogical knowledge courses, it can said that teacher candidates think that courses such as Instructional Technology and Material Design, Introduction to Educational Sciences, the Turkish Education System and School Management do not contribute to the teaching profession.

In field training courses, it would be seen that Science teacher candidates Nature of Science and History of Science (26) and Maths teacher candidates the Subject Area Textbook Review (8) think do not contribute to in terms of teaching profession more than other courses.

Findings Related to the Second Sub-Problem of the Research

Teacher candidates were asked courses should be in the teacher education program. Examining the responses, the resulting categories are shown in the Table 2.

Table 2. Courses Should be in Teacher Training Program

Category	Science Teacher Candidates		Mathematics Teacher Candidates			
	Courses	f	%	Courses	f	%
Art	Art (1), Picture (17), Music (12), Caricature (1), Guitar (2), Piano (1), Photography (5) Theatre (1), Handcraft (1), Dance (1), Sculpture(1)	43	24	Picture (2), Photography (2) Theatre (2), Radio and Television (2), Cinema (1)	9	10,2
Personal Development	Current Scientific Information (4) Personal Development (1), diction (12), Body Language (5), Fashion (1), Communication (3), Fine Writing (1), Mind Development (1), Reading Habits (1) Social Activity(1)	30	16,8	Liberal Education (3), Declamation-Diction (4) Ability for Empathy (1), Different Thinking Training (1), Social Activities-Trip (4)	13	14,8
Sport	Physical Education (20), athletics (2), Swimming (2), Mountaineering(1)	25	14	Swimming (1), Sports (1)	2	2,3
Technology	Information Technology Courses (1), Computer Programming (2), Animation Preparation (5), Smart Board Use (2)	10	5,6	Mathematical Programming (5), Web Design (4)	9	10,2
Field- Field Training	Food Science (2) Physiology (1) Quantum Physics (1), Basic Science Concepts (18), School Experience (14), Experimental Activity (6), Misconceptions in Science (9), Basic Physics (3), elementary Chemistry (2), Nature of Science (8)	64	35,7	Simple level / basic Math (17), Analysis (2), Basic Geometry (4), Misconceptions in Mathematics (8), Philosophy of Mathematics (2), History of Mathematics (2), Computer Aided Mathematics (1), More Teaching Practice (3)	39	44,3
Foreign Language	English (2), German (1), Multiple Languages (4)	7	3,9	English (1), Professional English (14), French (1)	16	18,2

Analyzing Table 2, the teacher candidates want to add to their teacher training program to the field/field training category more than others. It is seen that Science teacher candidates want to add to their program courses most often such as Basic Science Concepts (18), School Experience (14), and Misconceptions in Science (9). Mathematics teacher candidates mostly said that they wanted to add courses such as the level Simple / basic Math (17), Basic Geometry (4), and Misconceptions in Mathematics (8) to teacher training program. In addition, it can said that teacher candidates think courses such as arts, personal development and sports should be in their program. In Table 2, Even though teacher candidates have already received English lessons in their teacher training program, it is added in their program thinking that in the program should be. This situation may be due to they think that the content of the course needs to be replaced or increased hours of course. Mathematics teacher candidates use the expression that "vocational English" is noteworthy. As stated by Şahin et al. (2013), despite some of teacher candidates think that some courses are necessary for teacher training courses, its contents are to be organized according to the needs.

CONCLUSION

Results obtained by examination of the findings may be listed as follows:

1. It was determined that teacher candidates thought field courses more than others will not contribute to the teaching profession.
2. It was determined that courses such as Scientific Research Methods, Service Learning Course, Atatürk's Principles and History, Foreign Language-Eng., Computers, Elective Courses in liberal education category were common, and these courses were written by thinking that they will not contribute to the teaching profession.
3. It was seen that courses such as Technology and Material Design, Introduction to Educational Sciences, the Turkish Education System and School Management in pedagogical knowledge category were common, and these courses were written by thinking that they will not contribute to the teaching profession.
4. It was seen that Science teacher candidates thought Nature of Science and History of Science will not contribute teaching profession, mathematics teacher candidates thought Subject Area Textbook Review courses will not contribute to teaching profession in field training category.
5. It was seen that teacher candidates in both departments wanted to learn basic concepts such as basic science concepts, basic maths which will be used when they were teacher.

6. Even though they have already received courses such as English, art, music, school experiences, the nature of science in their teacher training programs, it was seen that these courses were added again in their training program.

RECOMMENDATIONS

At the end of the study, the following suggestions may be submitted:

1. Considering courses identified in the study, the reasons why think they will not contribute teaching profession can be ascertained.
2. It may be questioned why again added to the program courses such as English, art, music, school experiences, the nature of science.
3. Pedagogical knowledge courses are basic of teacher training program and are located in the teacher educational process. It is one of the interesting results that Teacher candidates think that Pedagogical knowledge will not contributing to the teaching profession. Thinking that why not contribute to this course may be the subject of future research.

REFERENCES

- Akbayır, K. And Tas, Z. (2009). Preservice Teachers' Views about Mathematics Education and Teacher Training. *Journal of Quafqaz University*, 26, 190-197.
- Aksu, M. (2005). "Changing Roles of the Faculty of Education and the European Dimension". GU G.E.F. *Results of Restructuring in the Faculty of Education and Teacher Training Symposium*. 22-24 September. Ankara.
- Arı, A. (2010). The Level of Knowledge and Skills of Elementary Education Program Students Gained at the Faculty of Education as Perceived by Prospective Teachers. *Journal of Ahmet Kelesoglu Education Faculty*, 29, 251-274.
- Bastürk, S. (2011). Mathematics Teacher Candidates' Evaluations of Teaching and Learning Process in Faculty of education. *Journal of International Human Sciences*, 8 (1), 58-94.
- Bulca, Y., Sacli, F., Kangalgil, M., Demirhan, G. (2009). Physical Education Teachers' Opinions on Efficacy Physical Education Teacher Education Program. Hacettepe University Scientific Research Project No: 0601407001. Ankara.
- Celik, S. and Arıkan, A. (2012). A Qualitative Study of the Effectiveness of Teacher Educations Programs in Preparing Primary School English Language Teachers. *Pamukkale University Journal of Education*, 32, 77-87.
- Cepni, S. (2012). *Introduction to research and project work* (6th edition). Trabzon: Celepler Printing.
- Hismanoglu, S. (2012). Prospective EFL Teachers' Views on English Language Teacher Training Program. *Journal of Research in Education and Teaching*, 1(2), 330-341.
- Inal, S. And Buyukyavuz, O. (2013). English Trainees' Opinions on Professional Developmant and Pre- Service Education. Hacettepe University Journal of Education, 28(2), 221-233.
- Karasar, N. (2013). *Scientific research method*. Ankara: Nobel Publishing.
- Milli Egitim Bakanlığı (2013). *The Science Curriculum*. Talim Terbiye Kurulu, Ankara.
- Ozkan, B. and Sahbaz, N. K. (2011). The Opinions of Turkish Teacher Candidates on Functionality of Field Courses. *Sakarya University Journal of Education*, 1, 32-43.
- Sahin, C., Kartal, O. Y., Imamoglu, A. (2013). The Opinions of Pre- School Teacher Candidates about Pre-School Teacher Education Program. *Ahi Evran University Journal of Kirsehir Education Faculty*, 14(1), 101-118.
- Sencer, M. (1989). *Methods in sociology*. Istanbul: Beta Publishing.
- Sisman, M. (2009). Teacher qualifications: a modern discourse and rhetoric. Inonu University Faculty Journal of Education, 10 (3), 63-82.
- Yavuzer, Y., Dikici, A., Caliskan, M., Aytekin, H. (2006). Calassroom Teacher Graduate Views on Level Benefit from Their Training Programs. *Cukurova University Journal of Education Faculty*, 2, 35-41.
- YOK. (1998). Faculty of Education Teacher Education Undergraduate Programs. YOK. Ankara <http://www.yok.gov.tr/egitim/ogretmen/ogretmen.htm> (Accessed on 16.04.2010).

ÖZEL ÖĞRETİM YÖNTEMLERİ II DERSİNDE GERÇEKLEŞTİRİLEN UYGULAMALARIN KİMYA ÖĞRETMEN ADAYLARI TARAFINDAN DEĞERLENDİRİLMESİ

Faik Özgür KARATAŞ

Canan CENGİZ

Öğretmen adaylarına öğretmenlik mesleği ile ilgili bilgi ve beceri kazandırmak için planlanan ve eğitim fakültelerinde yürütülen derslerden biri Özel Öğretim Yöntemleri (ÖÖY) dersidir. ÖÖY I dersinde öğretmen adaylarının temel öğrenme ve öğretme teorileri hakkında bilgi edinmeleri amaçlanırken, ÖÖY II dersinde öğretmen adaylarının çağdaş öğretme yaklaşımlarına uygun öğrenme ortamları tasarlamada deneyim kazanmaları ve özel öğretim yöntemlerinin temel ilkelerini kimya öğretiminde uygun bir şekilde kullanabilmeleri amaçlanmaktadır. Bu çalışmanın konusunu, öğretmen eğitiminde önemli olan; mikro öğretim ve yansıtıcı öğretim yöntemlerine dayalı olarak gerçekleştirilen ÖÖY II dersinin ve öğretmen adaylarının bu derste gerçekleştirdikleri öğretimin kendileri tarafından değerlendirilmesi oluşturmaktadır.

Çalışma 2012-2013 eğitim-öğretim güz yarıyılında, bir eğitim fakültesinin kimya öğretmenliği programında öğrenim görmekte olan 24 öğretmen adayı ile yürütülmüştür. Bu ders kapsamında her hafta iki öğretmen adayı daha önceden kendilerine kimya öğretimi programından seçilerek verilmiş konulara yönelik 40 dakikalık bir ders planı hazırlayarak sunmuşlardır. Dersler mikro öğretim yöntemine göre işlenmiştir ve dersin sonunda öğretmen adaylarından kendi öğretim uygulamaları ve dersin işlenişine yönelik yansıtma ve değerlendirmeler yapmalarını sağlamak için 10 yönlendirici sorudan (promth questions) oluşan ve araştırmacılardan biri tarafından geliştirilen değerlendirme formunu doldurmaları istenmiştir. Değerlendirme formu aynı zamanda bu çalışmanın veri toplama aracı olarak kullanılmıştır. Öğretmen adaylarının değerlendirme formlarındaki sorulara verdikleri cevaplar içerik analizi yoluyla çözümlenmiştir.

Öğretmen adaylarının ÖÖY II dersinde gerçekleştirdikleri öğretim uygulamaları süresince karşılaştıkları problemler öğretim sürecine yönelik problemler, planlamaya yönelik problemler, iletişime yönelik problemler, sınıf yönetimine yönelik problemler ve alan bilgisine yönelik problemler olmak üzere beş tema altında toplanmıştır. Ayrıca bulgular öğretmen adaylarının genel olarak ÖÖY II dersinde mikro öğretim yönteminin kullanılmasına yönelik olumlu görüşleri olduğunu göstermektedir. Öğretmen adayları uygulama sayesinde acemiliklerini üzerlerinden attıklarını, heyecanlarının azaldığını ve kendilerine duydukları güvenin arttığını belirtmişlerdir. Çalışmadan elde edilen veriler doğrultusunda ÖÖY II dersinde mikro öğretim yöntemi kullanmanın öğretmen adaylarının gelişimlerini olumlu yönde etkilediği sonucuna varılmıştır.

Anahtar Kelimeler: Özel Öğretim Yöntemleri Dersi, Mikro Öğretim, Yansıtıcı Öğretim

oooooooooooooooooooo

ÖZEL ÖĞRETİM YÖNTEMLERİ II DERSİNDE GERÇEKLEŞTİRİLEN UYGULAMALARIN KİMYA ÖĞRETMEN ADAYLARI TARAFINDAN DEĞERLENDİRİLMESİ

Faik Özgür KARATAŞ

Canan CENGİZ

One of the courses conducted in schools of education is Special Education Methods (SEM) which has been planned to make pre-service teachers gain knowledge and skills about teaching profession. In SEM courses, it is aimed for pre-service teachers to acquire knowledge about basic learning and teaching theories; while in SEM II course, the target is to make pre-service teachers gain experience in designing learning situations according to modern learning approaches and using the basic principles of special education methods in chemistry education. The subject of this research is constituted of SEM II course which was conducted based on micro-teaching and reflective teaching methods and the evaluation of the education in this course and self-evaluation by pre-service teachers.

The study is conducted in 2012-2013 fall semester, Chemistry teaching department of an education faculty with 24 pre-service teachers. Throughout the lesson each pre-service teachers prepared and presented a previously chosen topic from the chemistry teaching program for 40 minutes. The classes were conveyed according to the micro-teaching method and at the end of the class pre-service teachers were asked to fill an evaluation form with 10 prompt questions which is prepared by one of the researchers in order for the pre-service teachers to evaluate and reflect on their own teaching methods and the way that the class is conducted. The evaluation form is also used as the data gathering device of this study. The answers given by the pre-service teachers in the evaluation forms were analyzed by content analysis method.

Pre-service teachers' problems that they encountered during their teaching practices in SEM II Course are identified in five themes as problems related to the teaching process, problems related to planning, problems related to communication, problems related to classroom management and problems related to content knowledge. Also the findings shows that pre-service teachers have positive opinions about using micro teaching method in SEM II course. The pre-service teachers said that they get experienced and their excitement decreased and their self-confidence increased. Based on the finding of this study it can be said that using microteaching method in SEM II course effects pre-service teachers' development positively.

Keywords: special teaching methods lesson, micro teaching, reflective teaching

SOLVING A NUMBER PLACEMENT GAME USING RECURSIVE BACKTRACKING ALGORITHM ON THE GRAPH MODEL

Sema BODUR
Ege University
sema.bodur@ege.edu.tr

Sevcan EMEK
Ege University
sevcan.emek@ege.edu.tr

ABSTRACT: In this study, a number placement game has been developed. This application is designed on a graph model. Recursive backtracking algorithm was used in the solution of this game. Numbers on a board of $n \times n$ will be placed in a certain order under specified rules in finite time. With backtracking algorithm based on depth first recursive search method, finite number of possible solutions has been revealed. In this application that was inspired by 8-Queen problem, Knight's Tour, coloring a map, Knapsack problem and other search problems, advantages and disadvantages of this method have been discussed. The larger the board size, the much more the number of placement complexity. In further studies, the solution of this problem can be possible with the use of heuristic or informative search techniques.

Key words: Backtracking, Graph, Depth-first Search Algorithm

INTRODUCTION

Nowadays, in every sector, millions and billions of data is processed by computers. Weather forecasts from statistical analysis, patients' records sampling and finding suitable marrow, image processing and face recognition systems, training data from test drives, finding the correct way from different road routes, learning through entertainments etc. in almost every field of knowledge in computer processing have made important contributions to our daily life as well as to our future. Numerous data processed electronically in the fastest way using the least memory and few resources enabling to be accessible at a lower cost. Therefore, depending on the field of data used in the data structure to achieve the objective, mathematical model, applied algorithm and methods used are important.

In the real world, computer science contributions are very important in solving complex mathematical problems. In solving a problem, mathematical structure that are included in models must exist. Discrete structures such as trees, graphs, permutation and probabilities, equations and finite state machines are used in mathematical modeling. After modeling the problem, it is necessary to determine the best algorithm that will lead to a solution.

In this study, we are expected to place a sequence of all data set in an area of $n \times n$ in such a way that no gap is accommodated according to the specified rules. All possible solutions are searched by graph structures using backtracking algorithm. This application; maze problems, 8 queens are aligned on the chessboard while the knights are placed in L position in such a way that they don't eat each other [1] and likewise sudokupuzzle has been an inspiration in the development of such applications. Methods in application are used in detection of right path from the possible paths, the results and recommendations are discussed in details in the relevant sections.

Graph Theory

One of the branches of Mathematics known as Graph Theory, is commonly encountered in day to day life whereby in many cases the creation of a mathematical model that enables us to solve easily using different techniques from the common known methods. Expressing in a mathematical way, a G graph is formed by V; a set of elements of vertices and E; a set of elements of edges that connects any two non-binary vertices. Each elements of E is referred to as an edge(West, 2001). Directed graph is expressed by respective pairs of the vertices [2].

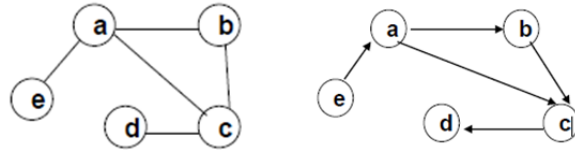

Figure 1. Graph and Directed Graph

In this study the matrix cells are formed by vertices of the graph while in a case where one cell is directed to another cell, the formation is by edges of the graph.

Backtracking Algorithm

In problems of achieving the goals, it is important to choose the right path. Backtracking algorithm tends to find a right path from the followed paths to reach the goal. All possible paths of the problem within the boundaries are tested. When unsuccessful path is followed or a path fails to reach a solution, it is abandoned and a previous step is followed to return back and that path is eliminated. Figure 2 shows the paths from the point of source to the goal.

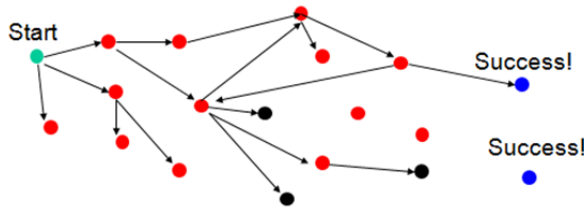

Figure 2. Backtracking Example [3]

Depth-first search algorithm is a very important part of Backtracking. Depth-first search (DFS) is an algorithm for traversing or searching tree or graph data structures. In DFS, a starting node is selected. Within the constraints of the problem, the nodes that are adjacent to neighboring nodes are added to form tree or a graph structure [4]. A right path from the source to the goal is found from all possible paths using backtracking depth-first search algorithm. Figure 3 shows part of the nodes from the point of source to the goal.

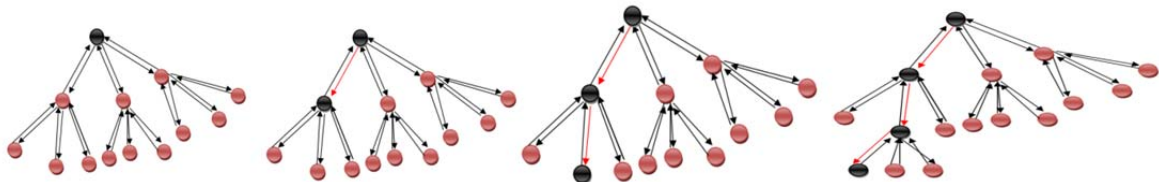

Figure 3. Application Example

In this study all possible paths that lead to the goal are taken into consideration. Backtracking depth-first search algorithm is one of the best methods for this application [5].

DEVELOPMENT OF APPLICATION

Problem Definition

In developing this application, 5x5 board model is transformed to 5x5 matrix form. The numbers are placed in a matrix form in accordance with specified rules.

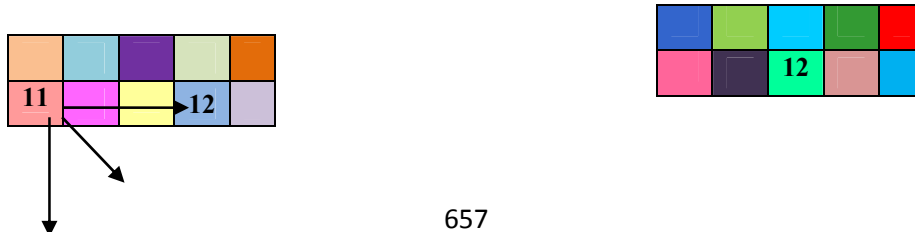

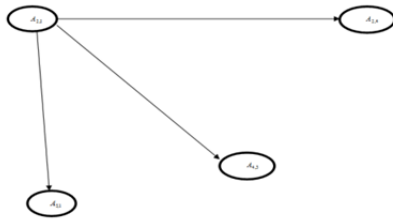

Figure 4. Number Placement Rules

In the figure $A_{2,1}$ above, the number placed on the vertex and the vertex that the next number can be placed on are shown. Our rules;

- 1- Numbers must be placed in sequential order starting from 0 or 1.
- 2- After placing a number, the next number to be placed can be placed in the same column or row after 2 empty gaps or in a diagonal way if there is free space.
- 3- For the game to end successfully, all numbers need to be placed.

Solution Algorithm

In our studies, the graph model of 25 vertices and 38 edges is shown in Figure 5.

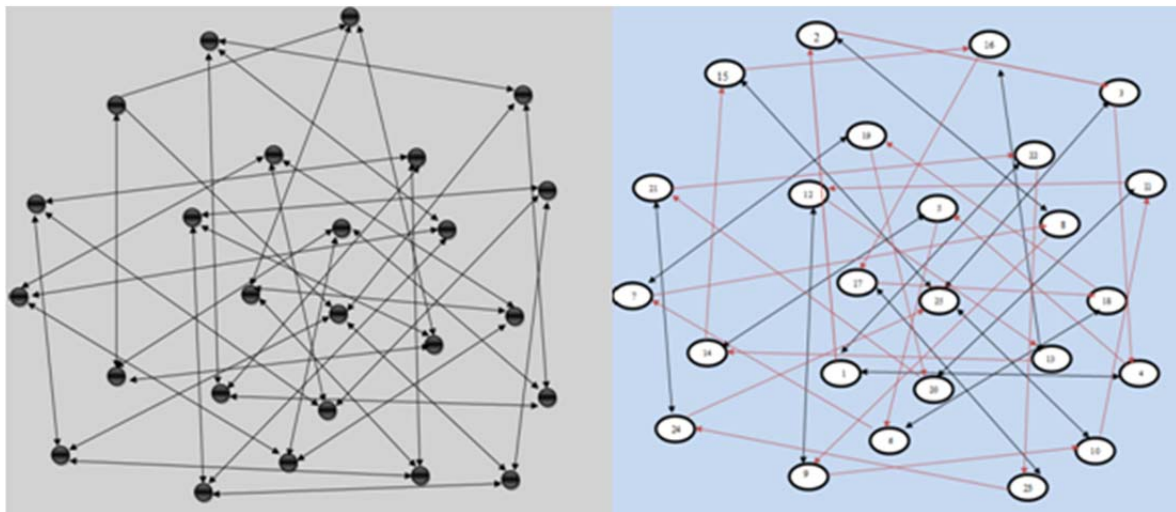

Figure 5. Number Placement Game Graph Model.

DFS pseudocode is as follows:[6]

```

public static void DFS (Graph g, Object vertex) {
    g.visit(vertex);
    Iterator itr = g.neighbors(vertex);
    while (itr.hasNext()) {
        Object v = itr.next();
        if (!g.isVisited(v))
            DFS(g, v);
    }
}

```

The most prominent feature of the problem is the placement pattern of the numbers on the matrix. In a square matrix being 5 x5, to go from the starting point or adjacent nodes, number of nodes is maximum 3 or 4. This condition is shown in Figure 6.

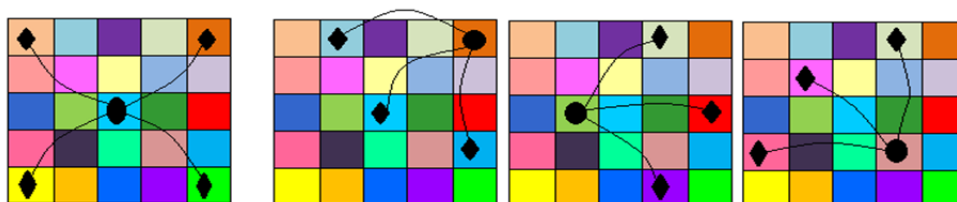

Figure 6. Destination Number of Nodes

In Figure 6, if the node position on the left is $A_{2,2}$, then the maximum number of 4 alternative nodes can be placed after itself. In the right table 3, maximum number of 3 alternative nodes can be placed.

In the process of programming our game, a sequence of rules is formed by defining the board size in x-y axis movement.

$move_x = \{ 2, 2, -2, -2, 3, 0, -3, 0 \};$
 $move_y = \{ 2, -2, 2, -2, 0, 3, 0, -3 \};$

According to this x-y motion, all of the numbers are placed step by step in appropriate regions. Number of "0" is start point. Start node can be selected randomly. After number of "0" is placed in $A_{3,3}$, placement of number 1 is decided. Number 1 can be placed (-2,+2) units after $A_{3,3}$ point. Then, number of "2" is placed in $A_{1,4}$. As long as the correct spacing exists the remaining numbers can be placed.

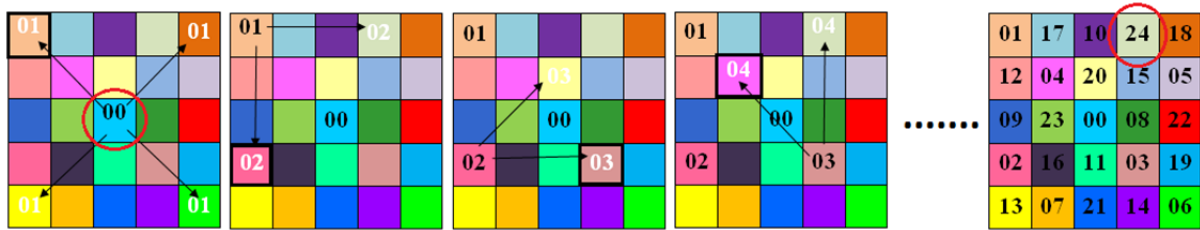

Figure 7. Step by step number placement

In solution process;

- Assigning of the movement point, in other words starting node,
- Calculation of new movement coordinates,
- Alternative nodes test or trial,
- Testing the validity of the new step coordinates,
- Not returning the previous node.

the steps above should be paid attention.

RESULTS AND FINDINGS

Position of starting node can be selected randomly on the board. Number of "0" surrounded by green is start node and number of "24" surrounded by red is goal node. All of the numbers are placed according to rules. As shown below, all of the numbers from 0 to 24 have been placed successfully on the board. Figure 8 shows the successful possible paths.

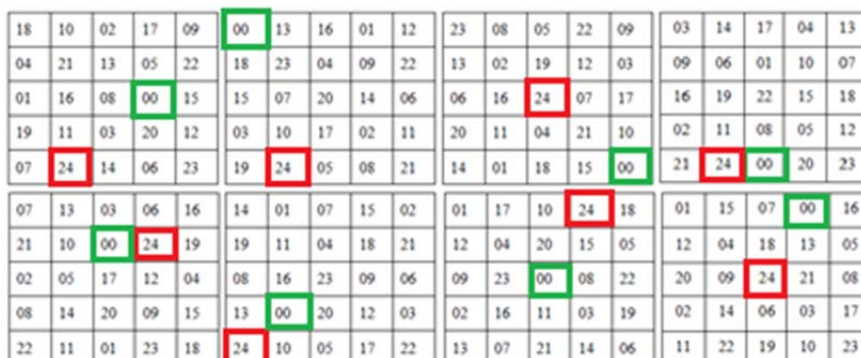

Figure 8. Numbers placed successfully

Figure 9 shows the steps of placing numbers according to their rules.

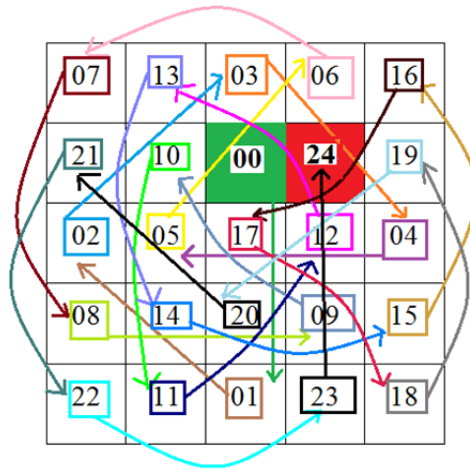

Figure 9. Example of a success path

Figure 10 shows unsuccessfully finished game with wrong paths. The numbers which are turned round by yellow colour in the cell can't move because there were no other number of steps to make a move it turns to the previous node with Backtracking. It evaluates other possible move. Thus, all possible outcomes are scanned in the search space.

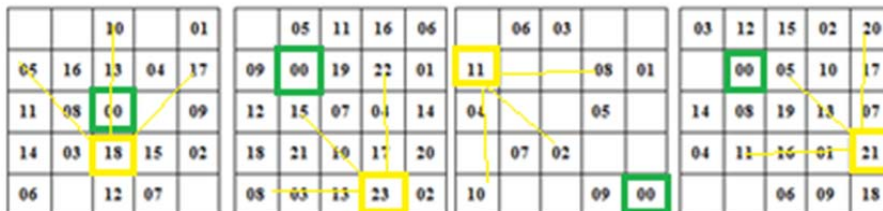

Figure 10. Unsuccessful paths

Probability Calculations: Although the probability condition totals to $(25 \times 24 \times 23 \dots 1) / 5!$, if we consider every possibility which doesn't contain solution, our searching space size would quite decrease. Considering our limitations;

After placing the first number on any of the 25 cells, the total number of moves sums to 23 and since at each move that can be made differently totals to 3, this makes the searching space size to be $25 \times 3^{22} \times 2$

CONCLUSION AND FUTURE WORK

In this study, by placement of sequence of numbers in accordance with certain rules based on the board enabled us to develop a game. In this game, the player uses all numbers with an aim of finding possible solution paths. Thus, an individual's trial and error method of analysing different ways and decision making skills are provided and improved.

In this application, 5x5 square has been tested on the board. The field can be expanded, hence possible paths are increased. Game rules defining the placement pattern of numbers can be changed. The dimensions of the playing field can be increased, 2 dimensional space can be transformed to 3 dimensional space. Exploration of our game on the possible right paths using heuristic algorithms based on learning methods may be put in trial. Thus unsuccessful paths can be avoided and the right paths can be found without selecting wrong paths. As we progress in our studies, this kind of applications can be used to compare methods based on informed and uninformed search algorithms.

REFERENCES

1. Gordon, V. S., & Slocum, T. J. (2004). The Knight's Tour- Evolutionary vs. Depth-First Search, IEEE
2. Tounsi, M., CS 311 Design and Algorithm Analysis Course: info.psu.edu.sa/psu/cis/mtounsi/~CS311/Chap-BKT-BB.pp

3. Dündar, P. &Balcı, A.M. &Kılıç, E. (2011). Mathematical Modelling of Placement of Emergency Phone Centres in a Campus Network.*DEÜ Mühendislik Fakültesi Mühendislik Bilimleri Dergisi*, Sayı 13,Cilt 1
4. Retrieved April 29, 2014 fromtheWikipedia :http://en.wikipedia.org/wiki/Depth-first_search
5. Problem Solving with Algorithms and Data Structures :
<http://interactivepython.org/runestone/static/pythonds/Graphs/graphdfs.html>
6. Retrieved April 29, 2014 from<http://www.academic.marist.edu/~jzbv/algorithms/Backtracking.htm>

BİYOLOJİ DERSLERİNDE AKILLI TAHTA KULLANIMINA İLİŞKİN ÖĞRENCİ TUTUMLARI

STUDENTS' ATTITUDES TOWARDS THE USE OF INTERACTIVE WHITEBOARDS IN BIOLOGY COURSE

İ.Ümit YAPICI
Dicle Üniversitesi
iuyapici@gmail.com

Murat HEVEDANLI
Dicle Üniversitesi
murathevedanli@dicle.edu.tr

ÖZET: Bu araştırmada; lise öğrencilerinin biyoloji derslerinde akıllı tahta kullanımına ilişkin tutumlarının belirlenmesi amaçlanmıştır. Tarama modelinin kullanıldığı araştırmada; çalışma grubunu 200 lise öğrencisi oluşturmaktadır. Veri toplama aracı olarak, Elaziz (2008) tarafından hazırlanan “Akıllı Tahta Kullanımına İlişkin Öğrenci Tutum Ölçeği” kullanılmıştır. Ölçeğin güvenirlik katsayısı 0,78; bu araştırmada ise 0,87 olarak hesaplanmıştır. Verilerin analizi sonucunda; öğrencilerin genel anlamda olumlu tutuma sahip olduğu söylenebilir. Sonuç olarak; akıllı tahta kullanımının biyoloji derslerinde özellikle; konuların daha kolay ve hızlı anlaşılması, zaman tasarrufu, görsel öğelerin etkisiyle ilgi ve motivasyonun artması vb. gibi avantajlar sağladığı söylenebilir. Öğrencilerin tutum puanları; “cinsiyet” ve “akıllı tahtanın kullanım süresi” değişkenlerine göre istatistiksel olarak farklılık göstermemektedir.

Anahtar sözcükler: Biyoloji, akıllı tahta, tutum.

ABSTRACT: The present study aims to determine the high school students' attitudes towards the use of interactive whiteboard in biology course. The survey model was used as research model. The study group included 200 high school students. As the data collection tools; students' attitudes scale towards the use of interactive whiteboard. Reliability coefficient of the scale was found Cronbach Alpha=0,87. For the analysis of the data, mean scores, t-test and ANOVA were used. The research results revealed that the use of interactive whiteboard especially in biology classes provide some advantages such as; understanding of the issues easier and faster, saving time, increasing interest and motivation with the effect of visual elements and so on. There was no significant difference between students' attitudes towards the use of interactive whiteboard in biology course with respect to gender and duration of use.

Key words: Biology, interactive whiteboard, attitude.

KARİKATÜRLERİYLE DESTEKLENEN FEN VE TEKNOLOJİ ÖĞRETİMİNİN ÖĞRENCİLERİN AKADEMİK BAŞARILARINA ETKİSİ

THE EFFECT OF SCIENCE AND TECHNOLOGY TEACHING SUPPORTED WITH CONCEPT CARTOONS ON STUDENTS' ACADEMIC ACHIEVEMENT

Ramazan DEMİREL
Bozkır İlçe Mili Eğitim Müdürlüğü
ramazandemirel.42@hotmail.com

Oktay ASLAN
Necmettin Erbakan Üniversitesi Fen Bilgisi Eğitimi Anabilim Dalı
oktayaaslan@gmail.com

ÖZET: Bu çalışmanın amacı kavram karikatürleri ile desteklenen Fen ve Teknoloji öğretiminin öğrencilerin akademik başarıları üzerine etkisini belirlemektir. Araştırmada ön test son test kontrol gruplu yarı deneysel desen kullanılmıştır. Araştırmanın örneklemi 7. sınıflardan, deney grubunda 15 ve kontrol grubunda 16 olmak üzere toplam 31 öğrenciden oluşmaktadır. Dersler Güneş Sistemi ve Ötesi ünitesi süresince deney grubunda kavram karikatürleri ile desteklenerek, kontrol grubunda ise programın öngördüğü şekilde işlenmiştir. Araştırmanın verileri; akademik başarı testi ile elde edilmiştir. Toplanan veriler SPSS 16 programıyla analiz edilmiştir. Akademik başarı testlerinden elde edilen grup puanlarının karşılaştırılmasında parametrik olmayan istatistiklerin analizinde kullanılan Mann-Whitney U testinden faydalanılmıştır. Yapılan uygulama sonrasında, öğrencilerin akademik başarıları açısından anlamlı farklılık elde edilmemiştir. Kavram karikatürleri mevcut programla akademik başarı açısından benzer etkilere yol açmıştır.

Anahtar sözcükler: Fen ve teknoloji öğretimi, kavram karikatürleri, Güneş sistemi ve ötesi, Akademik başarı

ABSTRACT: The aim of this study is to determine the effect of science and technology teaching promoted with concept cartoons on students' academic achievement. Semi-experimental pattern with pre-test and posttest control group was used in the study. The study was conducted with 31 students in total, 15 of whom were in the experiment grup and 16 of whom were in the control group, who were studying at a 7 th grade primary school. In the control group, the lectures were given in line with the current Science and Technology curriculum, while in the experimental group they were supported with concept cartoons. The data of the research was collected via Academic Achievement Test. Data obtained were analyzed through the analysis program SPSS16. Mann-Whitney U test which use nonparametric analysis was used for group points obtained from the academic achievement test. At the end of the study, there isn't any meaningful difference academic achievement. There is no significant difference between The Solar System and beyond unit supported by the processing current program and by the concept cartoons in terms of academic achievement. But there is meaningful difference on the post-test scores of conceptual understanding test. It has been identified that application reduces students' misconceptions that are available, it doesn't reveal new misconceptions and it has provided students with a better understanding.

Key words: Teaching science and technology, concept cartoons, the Solar System and beyond, academic achievement

GİRİŞ

Bilim ve teknoloji her geçen gün ilerlemektedir. Gelişen bilim ve teknoloji uygulamaları, öğretim yöntemlerinin de düzenlenmesini gerektirmektedir. Dewey: “*Bize öğretilenler gibi öğretmeye devam ediyorsak çocuklarımızın geleceğinden çalışıyoruz demektir*” ifadesini kullanarak öğretim yöntemlerinin revize edilmesinin gerekliliğini belirtmiştir. Öğrencilerin aktif olduğu, bilgileri sorgulayarak kendilerinin yapılandırmasına olanak sağlayan, öğrencilerin önbilgilerini, kavram yanlışlarını ortaya çıkaran yöntemler önem kazanmıştır. Fen bilimlerinin muhtevasının çoğunluğu soyut konulardan oluştuğundan öğrenciler Fen ve Teknolojideki kavramlara ait bilimsel doğrulardan farklı düşünceler oluşturmaktadırlar. Fen alanında yapılan araştırmaların çoğunluğu

öğrencilerin kavram yanlışları üzerine yapılmıştır. Kavram karikatürleri yapılandırmacı yaklaşıma uyan ve öğrencilerin önbilgileri açığa çıkaran bir yöntem olarak kullanılmaktadır.

Kavram Karikatürleri

Kavram karikatürleri bilimsel bir kavram ya da günlük bir olayla ilgili farklı görüşler belirtmek amacıyla yapılan karikatür tarzı çizimlerdir (Naylor & Keogh,1999). Kavram karikatürlerinde üç ya da daha fazla karakter bir konu hakkında tartışmaktadır (Şaşmaz-Ören, 2009). Kavram karikatürlerinde olabildiğince az sayıda şekil ve metinle konunun görsel olarak ifade edilmesi önem taşımaktadır (Baysarı, 2007). Kavram karikatürlerinde tartışan karakterlerden birinin görüşü bilimsel olarak doğrudur, diğer karakterlerin belirttiği ifadeler öğrencilerde bulunması muhtemel kavram yanlışları ve yanlış anlamaları içermektedir.

Öğrenciler karikatürde verilen olayı düşünür, araştırır ve arkadaşlarıyla fikir alışverişinde bulunur (Demir,2008). Kavram karikatürleri tartışma ortamının oluşturulması, tartışmanın başlatılması ve devam ettirilmesinde etkili materyallerdendir. Kavram karikatürleri poster olarak, Fen ve Teknoloji derslerinde öğretim yöntemi ve materyali olarak kullanılabilir (Kabapınar,2009).

İlkokul ve ortaokul öğrencileri, öğretmenler ve öğretmen adaylarıyla yapılan görüşmelerde kavram karikatürlerinin kullanılmasıyla ilgili olarak katılımcılar olumlu görüş bildirmişlerdir (Keogh & Naylor,2013). Kavram karikatürleri, motivasyonu artırma, alternatif bakış açılarından haberdar etme, tartışmaya yöneltme, konuyu özetleme ve değerlendirme amacıyla kullanılmaktadır (Naylor & Keogh, 2010).

Kavram karikatürleri gündelik hayata uygun olmalı, çok fazla bilimselliğe odaklanılmamalıdır. Alternatif bakış açılarının yanında bilimsel doğrularda verilmelidir. Öğrencilerde bulunan farklı görüşleri öğrenmek adına karikatürlerde boş konuşma baloncuklara da yer verilmelidir. Kavram karikatürlerinde bulunan alternatif düşünceler eşit statüde verilmelidir. Kavram karikatürlerinde sık kullanılan kavram yanlışlarının öğrencilerde yaygınlaşmadığı, karikatürlerin kavram yanlışlarının giderilmesinde etkili materyallerden olduğu görülmüştür. (Keogh & Naylor, 2013).

Araştırmanın Amacı

Araştırmanın amacı: 7. sınıf Fen ve Teknoloji dersi Güneş sistemi ve Ötesi: Uzay Bilmecesi ünitesinde yer alan konuların kavram karikatürleriyle desteklenerek işlenmesinin öğrencilerin akademik başarısına etkisini ortaya çıkarmaktır. Bu çalışmada: Fen ve Teknoloji öğretiminde, ünitenin kavram karikatürleri ile desteklenerek işlenmesi ile mevcut programla işlenmesinde öğrencilerin akademik başarıları açısından anlamlı bir fark var mıdır? Sorusuna yanıt almaya çalışılmıştır.

YÖNTEM

Araştırmanın Modeli

Bu çalışmada ön test-son test kontrol gruplu yarı deneysel desen kullanılmıştır. Birbirine denk gruplardan biri deney, biri kontrol grubu olarak yansız bir şekilde atanır. Deney ve kontrol gruplarına uygulama yapılmadan ve uygulama yapıldıktan sonra test uygulanır (Büyüköztürk, Çakmak, Akgün, Karadeniz ve Demirel, 2010). Deney grubuna ve kontrol grubuna Fen ve Teknoloji başarı testi, ön test ve son test olarak uygulanmıştır.

Çalışma Grubu ve Özellikleri

Bu çalışma 2012-2013 eğitim-öğretim yılı ikinci döneminde Konya ili Bozkır ilçesi Dereçi ortaokulunda 7. sınıf öğrencileri ile gerçekleştirilmiştir. Çalışmada 15 öğrenci mevcudu olan 7/B sınıfı deney grubu, 16 öğrenci mevcudu olan 7/A sınıfı kontrol grubu olarak rastgele atanmıştır.

Çalışmada Kullanılan Kavram Karikatürlerinin Geliştirilmesi

Kavram karikatürleri hazırlanmadan önce, ele alınacak üniteye ilişkin kazanımlar incelenmiş daha sonra literatür taraması yoluyla konu ile ilgili olarak öğrencilerde olması muhtemel kavram yanlışları tespit edilmiştir. Kazanımlar ve bu konulardaki kavram yanlışları dikkate alınarak kavram karikatürleri geliştirilmiştir. Bazı karikatürlerin oluşturulmasında karikatür hazırlama sitelerinden yararlanılmış, diğerleri de elle çizilmiştir. Oluşturulan kavram karikatürlerinin uygunluğu alan eğitimcileri ve Fen ve Teknoloji öğretmenlerince incelenerek gerekli düzenlemeler yapılmıştır. Pilot uygulamalardan sonra nihai şekli verilen kavram karikatürleri toplamda 30 karikatür karesi olmak üzere 3 karikatür serisinden oluşmaktadır.

Kavram Karikatürlerinin Uygulanma Süreci

Kavram karikatürleri dersin başlangıç aşamasında öğrencilerde bulunan kavram yanlışları ortaya çıkarmada ve öğrencileri derse güdülemede, dersi sunuş yapma, açıklama ve genişletmede ve dersin sonunda değerlendirme amacıyla kullanılmıştır.

Deney grubunda dersler kavram karikatürleriyle desteklenerek, kontrol grubunda ise mevcut programa göre işlenmiştir. Deney ve kontrol grubunda dersler aynı Fen ve Teknoloji öğretmeni tarafından yürütülmüştür.

Verilerin Toplanması

Konya Bozkır Dereiçi ortaokulu 7/A (kontrol grubu) ve 7/B (deney grubu) sınıfı öğrencilerine Fen ve Teknoloji başarı testi ön test ve son test olarak uygulanmıştır.

Başarı Testi

Güneş Sistemi ve Ötesi: Uzay Bilmecesi ünitesi konularına ilişkin geliştirilen başarı testi ön test ve son test olarak uygulanmıştır. Test geliştirilirken: Güneş sistemi ve Ötesi Uzay Bilmecesi ünitesine ilişkin kazanımlar listelenmiştir. Fen ve Teknoloji başarı testi araştırmacı tarafından hazırlanmış, test hazırlanırken Seviye Belirleme Sınavı(SBS) hazırlık kitaplarından, fen okulu, kavramabilgi, mebvitamin gibi internet sitelerinden yararlanılmıştır. İlk olarak 75 maddeden oluşan çoktan seçmeli test, geçerlik ve güvenilirlik çalışmaları için Konya ili Bozkır ilçesindeki çeşitli okullardan Güneş Sistemi ve Ötesi ünitesini daha önceden ders olarak almış 212 ortaokul 8. sınıf öğrencisine uygulanmıştır.

Analiz sonucunda 35 soru testten çıkarılmış, 40 sorudan oluşan çoktan seçmeli Güneş Sistemi ve Ötesi başarı testi elde edilmiştir. Fen ve Teknoloji başarı testinin KR-20 güvenilirlik katsayısı 0,86 olarak hesaplanmıştır. Ön uygulama ve uzman görüşü alma sonrasında geçerliliği ve güvenilirliği düşük olan sorular testten çıkarılmıştır. Akademik başarı testinin ortalama madde güçlük indeksi 0,441 olarak hesaplanmıştır. Testin ortalama madde ayırt edicilik indeksi 0,314 olarak bulunmuştur.

Verilerin Analizi

Uygulama sonrasında elde edilen veriler SSPS16 paket programına aktarılmıştır. Öğrencilerin Fen ve Teknoloji başarı testi ön test son test puanlarının karşılaştırılması, anlamlı bir farkın olup olmadığının tespitinde parametrik olmayan istatistiklerin analizinde kullanılan “Mann-Whitney U” testinden faydalanılmıştır. Mann-Whitney U testi, ilişkisiz ölçümlerde az denekli deneysel çalışmalarda puanların dağılımının normal olmadığı deneysel çalışmalarda sıklıkla kullanılır. İlişkisiz t-testinin alternatifi olarak da bilinir. Araştırmada anlamlılık düzeyi $p < 0.05$ olarak alınmıştır (Büyüköztürk, 2011). Çalışma bitiminde deney grubundaki öğrencilerin tamamına yarı yapılandırılmış görüşme uygulanmış, öğrencilerin sorulara vermiş oldukları cevaplar öğretim yöntemi, bilişsel özellikler, duyuşsal özelliklerle ilgili olmalarına göre kategorize edilmiştir.

Başarı Testi’nden Elde Edilen Verilerin Analizi

40 sorudan oluşan başarı testine verilen doğru cevaplar tam puan, yanlış cevaplar ve boş bırakılan sorular 0 puan olarak puanlandırılmıştır. Başarı testi, deney ve kontrol grubu ön test ve son test olarak uygulanmıştır.

BULGULAR VE YORUM

Başarı Testinden Elde Edilen Bulgular

Uygulama öncesinde deney ve kontrol grubu öğrencilerinin, Fen ve Teknoloji dersi “Güneş Sistemi ve Ötesi” ünitesine yönelik ön bilgi düzeyleri arasında istatistiksel olarak anlamlı farklılık olup olmadığını tespit etmek amacıyla öğrencilere akademik başarı testi ön test olarak uygulanmıştır. Testten elde edilen veriler Tablo 1’ de verilmiştir.

Tablo 1. Deney ve Kontrol Grupları Başarı Ön-Test Puanlarının Karşılaştırılması

Grup	N	Sıra ortalaması	Sıra toplamı	U	P
Kontrol	16	14,13	226,00	90,000	.247
Deney	15	18,00	270,00		

Tablo 1’de görüldüğü gibi uygulama yapılmadan önce, deney grubu ve kontrol grubu akademik başarıları arasında istatistiksel olarak anlamlı bir farklılık olmadığı tespit edilmiştir (U=90,00; p>.05).

Tablo 2. Deney ve Kontrol Grupları Başarı Son-Test Puanları Karşılaştırılması

Grup	N	Sıra ortalaması	Sıra toplamı	U	P
Kontrol	16	14,25	228,00	92,000	.281
Deney	15	17,87	268,00		

Tablo 2’ de görüldüğü gibi, son testte, deney ve kontrol gruplarının akademik başarı puanları arasında anlamlı bir farklılık yoktur (U=92,00; p>.05).

Kavram karikatürleri 7. Sınıf Güneş Sistemi ve Ötesi ünitesinde öğrencilerin akademik başarılarında mevcut programla benzer etkilere yol açmıştır, öğrencilerin akademik başarılarında anlamlı bir farklılık gözlenmemiştir.

SONUÇLAR VE TARTIŞMA

Bu bölümde, verilerin analizi sonucunda elde edilen bulgular göz önüne alınarak yapılan sonuçlar ve önerilere yer verilmiştir.

Akademik Başarı Testine ilişkin sonuçlar

Yapılan araştırmada Güneş Sistemi ve Ötesi ünitesi kontrol grubunda mevcut öğretim programıyla deney grubunda ise mevcut öğretim programı kavram karikatürleriyle desteklenerek işlenmiştir. Deney ve kontrol grubu akademik başarı son test puanları arasında anlamlı farklılık bulunamamıştır (U=92,00; p>.05). Kavram karikatürü destekli etkinliklerin öğrencilerin akademik başarıları üzerinde mevcut Fen ve Teknoloji öğretim programıyla benzer sonuçlar oluşturmuştur. Literatür incelendiği zaman benzer sonuçlar elde edilen araştırmalar bulunmaktadır. Baysarı (2007), Canlılar ve Hayat ünitesinde, Balım, İnel ve Evrekli (2008), Doğru ve Keleş (2010), “elektrik ünitesinde” kavram karikatürü destekli 5E modelinde, Yarar (2010), Sosyal Bilgiler dersinde flash programında hazırlanmış kavram karikatürleri ile destekli öğretimde, Çiçek (2011), 6. Sınıf öğrencileri ile yaptığı çalışmada kavram karikatürü kullanımı öğrencilerin akademik başarıları açısından anlamlı bir farklılık oluşturmamıştır.

Literatürde bazı araştırmalara göre farklı sonuçlar elde edilmiştir. Durmaz (2007),“Mitoz-Mayoz Hücre Bölünmeleri ve Kalıtım” ünitesinde, Özüredi (2009), İnsan ve Çevre ünitesinde, Eroğlu (2010), Maddenin Tanecikli Yapısı ünitesinde, Evrekli (2010), kavram karikatürü ve zihin haritalarının öğrenmeye etkisinde, Alkan (2010), sosyal bilgiler dersinde öğrencilerin akademik başarılarını artırmada kavram karikatürlerinin etkili olduğu sonucuna varılmıştır.

Araştırmadan elde edilen sonuçları şu şekilde özetleyebiliriz:

1)Kavram karikatürleri öğrencilerin derse güdülenmelerini sağladığı için öğretmenler tarafından dersin başlangıç aşamasında rahatlıkla kullanılabilir.

- 2) Kavram karikatürleri akademik başarıya oranla kavram yanlışlarını belirlemede daha etkili materyallerdendir.
- 3) Kavram karikatürleri özellikle çekingen öğrencilerin derse dâhil edilmesinde kolaylıkla kullanılabilir.
- 4) Kavram karikatürleri dersin başlangıcında, dersi sunumunda, ders sonunda değerlendirme aracı olarak kullanılabilir.
- 5) Kavram karikatürleri tartışma yoluyla öğrencilerin derse katılımını artırır.
- 6) Kavram karikatürleri kavram yanlışlarının belirlenmesi ve giderilmesinde etkili materyallerdendir.
- 7) Kavram karikatürleri konunun görsel olarak ifade edilmesini sağlar, öğrencileri alternatif görüşlerden haberdar eder, yeni kavram yanlışlarının oluşmasını engeller.

Öneriler

Kavram karikatürleriyle desteklenen Fen ve Teknoloji öğretiminin öğrencilerin akademik başarıları etkisi araştırmasından elde edilen veri analizlerine göre çıkarılabilecek öneriler şunlardır:

- 1) Kavram karikatürlerine ders kitaplarında sıklıkla yer verilip, poster şeklinde hazırlanıp sınıf duvarlarına asılabilir.
- 2) Kavram karikatürleri öğrencilere hazırlattırılabilir.
- 3) Kavram karikatürlerini öğrencilerin kavram yanlışlarının fazla olduğu konularda uygulamak daha etkili sonuçlar almayı sağlayacaktır.
- 4) Kavram karikatürleri ile yapılan araştırmalarda, kavram karikatürlerinin diğer yöntem ve tekniklerle beraber kullanılmasının etkisinin araştırılması daha olumlu sonuçlar almayı sağlayacaktır.
- 5) Kavram karikatürleri Fen ve Teknoloji dersi diğer ünitelerde ve diğer derslerde rahatlıkla kullanılabilir.
- 6) Kavram karikatürlerinin benzer şekilde ilkokul, lise, üniversite öğrencileri ve öğretmen adayları üzerine etkisi incelenebilir.

KAYNAKÇA

- Alkan, G. (2010). *Sosyal Bilgiler Öğretiminde Kavram Karikatürlerinin Öğrenci Başarısına Etkisi*. Yayınlanmamış Yüksek Lisans Tezi, Niğde Üniversitesi Sosyal Bilimler Enstitüsü, Niğde.
- Balım, A. G., İnel, D. ve Evrekli, E., (2008). *Fen öğretiminde kavram karikatürü kullanımının öğrencilerin akademik başarılarına ve sorgulayıcı öğrenme becerileri algılarına etkisi*. *İlköğretim Online*, 7 (1), 188–202.
- Baysarı, E. (2007). *İlköğretim düzeyinde 5. sınıf Fen ve Teknoloji dersi canlılar ve hayat ünitesi öğretiminde kavram karikatürü kullanımının öğrenci başarısına, fen tutumuna ve kavram yanlışlarının giderilmesine olan etkisi*. Yayınlanmamış yüksek lisans tezi. Dokuz Eylül Üniversitesi Eğitim Bilimleri Enstitüsü, İzmir.
- Büyüköztürk, Ş., Çakmak, E. K. Akgün, Ö. E. Karadeniz, Ş. ve Demirel, F. (2010). *Bilimsel Araştırma Yöntemleri*. Ankara: Pegem Akademi Yayınları.
- Büyüköztürk, Ş. (2011). *Veri Analizi El Kitabı (11. Baskı)*, PegemA Yayıncılık, Ankara.
- Çiçek, T. (2011). *İlköğretim 6. sınıf fen ve Teknoloji dersinde Kavram Karikatürlerinin Öğrenci başarısına, tutumuna ve kalıcılığına etkisi*. Celal Bayar Üniversitesi Fen bilimleri Enstitüsü Yüksek Lisans Tezi, Manisa.
- Demir, Y. (2008). *Kavram yanlışlarının belirlenmesinde kavram karikatürlerinin kullanılması*. Yayınlanmamış yüksek lisans tezi, Atatürk Üniversitesi Fen Bilimleri Enstitüsü, Erzurum.
- Doğru, M. & Keleş Ö. (2010). *Use Of Concept Cartoons with 5E Learning Model In Science And Technology Course. International Conference on New Trends in Education and Their Implications 11-13 November, 2010 Antalya-Turkey*.

- Durmaz, B. (2007). *Yapılandırıcı Fen Öğretiminde Kavram Karikatürlerinin Öğrencilerin Başarısı ve Duyuşsal Özelliklerine Etkisi (Muğla İli Merkez İlçe Örneği)*. Yayınlanmamış yüksek lisans tezi. Muğla Üniversitesi Fen Bilimleri Enstitüsü, Muğla
- Eroğlu, N. (2010). *6. Sınıf maddenin tanecikli yapısı ünitesindeki kavramların öğretiminde öğrenci ürünü karikatürlerin kullanımı*. Yayınlanmamış yüksek lisans tezi. Sakarya Üniversitesi Fen Bilimleri Enstitüsü, Sakarya.
- Evrekli, E. (2010). *Fen ve teknoloji öğretiminde zihin haritası ve kavram karikatürü etkinliklerin öğrencilerin akademik başarılarına ve sorgulayıcı öğrenme beceri algılarına etkisi*. Yayınlanmamış yüksek lisans tezi. Dokuz Eylül Üniversitesi Eğitim Bilimleri Enstitüsü, İzmir.
- Kabapınar, F. (2009). What makes concept cartoons more effective?: Using research to inform practice. *Education and Science*, 34 (154), 104-118.
- Keogh, B. & Naylor, S. (2000). *Teaching & learning in science using concept cartoons: why Dennis wants to stay in at playtime. Investigating: Australian Primary & Junior Science Journal*, 16 (3), 10-14.
- Keogh, B. & Naylor, S. (2013). Concept Cartoons: What have we learnt?, *Türk Fen Eğitimi Dergisi*, Mart 2013 3-11.
- Naylor, S. & Keogh, B. (1999). Constructivism in Classroom: Theory into practice. *Journal of Teaching Education*, 10(2), 93-106.
- Naylor, S. & Keogh, B. (2010). *Concept Cartoons in Science Education*. Millgate House Publishers.
- Özüredi, Ö. (2009). *Kavram karikatürlerinin ilköğretim 7. Sınıf fen ve teknoloji dersi, İnsan ve çevre ünitesinde yer alan "besin zinciri" konusunda öğrenci başarısı üzerindeki etkisi*. Yayınlanmamış yüksek lisans tezi. Celal Bayar Üniversitesi Fen Bilimleri Enstitüsü, Manisa.
- Şaşmaz Ören, F. (2009). Öğretmen adaylarının kavram karikatürü oluşturma becerilerinin dereceli puanlama anahtarıyla değerlendirilmesi. *E-Journal of New World Sciences Academy*, 4(3), 994-1016.
- Yarar, S. (2010). *Flash programında kavram karikatürleriyle desteklenerek hazırlanmış öğrenme nesnelerinin sosyal bilgiler dersinde kullanılması*. Yayınlanmamış yüksek lisans tezi, Rize Üniversitesi Sosyal Bilimler Enstitüsü, Rize.

EXAMINATION OF TEACHER CANDIDATES' METAPHORS RELATED TO TEACHER EDUCATION PROGRAMS

Gamze YAYLA
Cumhuriyet University
gamze_yyl@hotmail.com

Handan DEMİRCİOĞLU
Cumhuriyet University
handandemircioglu@gmail.com

ABSTRACT: This study was aimed to determine teacher candidates' metaphors related to teacher education programs. Research sample consisted of 230 seniors, who studied programs in Elementary Science and Technology Education (n=170) and Secondary Mathematics Education (n=60) Departments. The data were collected by means of the teacher candidates' completion of the statement "Teacher education programs are like ... because ...". In this research phenomenological research design was used and data were analyzed by means of content analysis. In the analysis, it was eliminated invalid metaphors and determined categories which are thought to represent metaphors. In the light of the findings, It was shown that teacher candidates produce 162 valid metaphor, and this metaphor collected in five categories in for action, tool/ material, environment, person have a profession, associated with life.

Key words: teacher education program, teacher candidates, metaphor

INTRODUCTION

Metaphors which are symbolic expressions create different meanings in individuals taking other meanings of words. (Dundar and Karaca, 2013). Metaphor is defined as "the word used in another meaning from the real meaning as a result of an interest or analogies, a word or use of other meaning than the accepted meaning of concept ofis" in Turkish Language Institution dictionary (TDK, 2008). Metaphors allow individuals to see a phenomenon as another phenomenon, and is a mental mapping mechanism to understand individuals' world (Karacanta, 2013). Shuell (1990: 102) stressed that "If a picture is worth 1000 words, a metaphor is worth 1000 picture." Because, while a picture provides only a static image, a metaphor provide a mental framework to think about the case. Therefore, using the metaphor we have stated our way of thinking about our understanding o concept or phenomena.

Its relationship of the analogy with metaphor is a known fact. However, metaphors and analogies are not completely overlaps. Both analogies and metaphors establish similes. However, this relationship is realized in different ways. While an analogy clearly compare two areas and show parts of their identify, metaphors highlighting features or associated attributes not changing in two areas, makes comparison implicitly, it not included high similarities or relationship among area (Duit, 1991). Therefore, metaphors have been used as a starting point in many scientific discovery and defined as a part of scientific process, and have been effective on the basis of know towards unknowns in the process of reasoning (Demirci Güler, 2012). In this context, metaphors are seen to be subject to research for determining perceptions towards some concepts in education. Ates and Karatepe (2013-a) analyzed that university students' perceptions towards "environment" concept with the help of methaphors. Ates and Karatepe (2013-b) analyzed university students' perceptions towards "Global Warming" concept with the help of methaphors. Aydin (2010) examined that Owned Metaphors of Secondary Students related to the concept "geography". Akkaya (2011) researched on perceptions of 8th grade elementary students about "speaking" concept. In the literature, it is seen that the identification of metaphors for different concepts such as these. The overall purpose of this study investigation ascribe meaning to the image of individuals and depicted situation in the education field, thanks to metaphors reflect cultural values, attitudes and thoughts of individuals.

In the nowadays are experienced rapid developments, because the task of rising qualified individuals adapt to the process of change are given to education system, teaching profession has come to the fore. No matter how qualified teachers and thus the quality of trained individuals will increase. Hence, the importance of teacher education programs arises.

The training for prospective teachers adopts the role of a teacher based on teacher education. Carter (2001) stated that metaphors used as a powerful tool in eliciting teacher candidates' opinions on their experiences

during their student years and their future thoughts about how they want to become a teacher. However, in the related literature studies examining metaphors for teacher education programs were not detected. Teacher candidates' beliefs about the program can explain the results consisting of experience with the help of metaphor. In this way, metaphors serve as a helpful tool transferring they want to tell.

In this context, the study has been conducted to reveal their metaphors of science and mathematics teacher candidates for teacher education programs. Starting from this idea, sub-problems of the research are as follows:

1. What are metaphors of science and mathematics teacher candidates related to teacher education program?
2. Which are conceptual categories that collected metaphors of science and mathematics teacher candidates related to teacher education program?
3. How are become different conceptual categories related to metaphors according to the department?

METHODS

In this study was used phenomenological research design. Phenomenography is a research method that dealing with people what they perceive phenomena encounter live in the universe and what are their experiences (Cekmez et al., 2012). Different individuals likewise do not understand the phenomenon. To experience or understand a phenomenon varies from person to person (Türkelî Sandir, 2006). Phenomenographic research is try to identify the key parts of this diversity (Trigwell, 2000).

Participants

Research sample consisted of 230 seniors, who studied programs in Elementary Science and Technology Education (n=170) and Secondary Mathematics Education (n=60) Departments.

Data Collection Instruments and Data Analysis

The data were collected by means of the teacher candidates' completion of the statement "Teacher education programs are like ... because ...". Teacher candidates' answers were analyzed by using content analysis.

FINDINGS AND DISCUSSION

When metaphors derived from the teacher candidates examined, the following was observed:

- 162 (including 45 from mathematics teacher candidates and 117 from science teacher candidates) has been found to be valid metaphor. 57 of these metaphors such as make a food (6), book(10), passenger bus(2), computer(3), encyclopedia(3), branched tree(2), factory(11), raise trees(2), vaccine(2), kitchen(2), hospital(2), library(2), construction(2), potter's workshop(2), sculptor(4), life(2) are common. The remaining 105 metaphor are represented by one person.
- 37 metaphors such as Rowing on the lake (1), Workout (1), Make to modify a car (1), Produce fabricated violin (1), Very fancy gift package (1), Closed box (1), Made in China products (1), Snowman (1), Cigarette (1), Have put a lot of water into the dough (1), Electrical installations in Schools (1), Blinkers (1), Robot (1), Factory(7), Farm (1), Cafe(2), One type of machine producing factory (1), Bank Note Printing House (1), Rest of the resort (1), Building (1), Guesthouse (1), Maze (1), Penitentiary (1), System that unchanging outcomes(1), Ineffective element (1), Platonic love (1), Anger (1), Chinese torture (1), Empty brain (1) are negative as the content, 15 metaphors such as Family(1), Sculptor(4), Information home(1), Sun(1), Newly planted seedings(1), Vaccine(2), To improve doctor's patients(1), Flower garden(1), Art workshop(1), Individual development book(1), Fruit trees(1) are positive as the content, and the rest of 110 metaphor was found to be neutral in the sense that the mutual processes.
- The metaphors derived from teacher candidates are categorized in terms of the meanings they contain, consisting of five categories shown in the table.

Table 1. Metaphors and Categories Related to Teacher Education Program

Category	Science Teacher Candidates		Mathematics Teacher Candidates			
	Mehaphors	f	%	Methaphors	f	%
As “an action”	Raise tress(1),Drink Water(1), Make a picture(1),Write articles(1),Read the book(1), To improve doctor's patients(1),Working in the office(1),Educating child(1),Baby's growth(1),Rowing on the lake(1), Make a pottery(1),Make a food (6),Exhausting marathon(1), Workout(1), Racing(1)	20	17,1	Raise tress(1), Make to modify a car (1), Produce fabricated violin(1), RNA synthesis(1), Raise flower(1), The building is to be constructed(1), Process of tree growth(1)	7	15,6
As a “a tool/ material”	Vaccine(1), Encyclopedia(1),Pyramid(1), Individual development book(1), Rungs of the ladder(1),Book(10), Very fancy gift package(1), Regular running machine(1), Passenger bus(2), Hour(1), Closed box(1), Made in China products(1), Computer(3), A car engine(1), Clothes(1), Bridge(1), Snowman(1)	29	24,8	Vaccine(1), Encyclopedia(2), Mud, clay(1), Notebook(1), Cigarette(1), Have put a lot of water into the dough(1), Electrical installations in Schools (1), Blinkers(1), TV(1),Robot(1), Macig wand(1),	12	26,7
As “ an environment”	Factory(5), Kitchen(1), Hospital(1), Industry(1),Beehive(1), Hotel(1), One type of machine producing factory(1), Hammam(1), Football Field(1), Building(1), Library(2), Bank Note Printing House(1), Water storage(1), Flower garden(1), Bakery(1), Construction(2), Market(1), Forest(1), Hairdresser(1), Maze(1), Home(1), Guesthouse(1), Space(1), Penitentiary(1), Repository(1), Refectory(1), Workshop(1), The shooting range(1), The foundation of building(1), Recycling center(1), Information home(1)	37	31,6	Factory(6), Kitchen(1), Hospital(1), Farm(1), Field(1),Cafe(1), Potter’s workshop(2), Rest of the resort(1), Art workshop(1), Center of a city(1)	16	35,5
As “ a person have a profession”	Sculptor(3), Cook(1), Worker(1), Tailor(1), Kindergarten teacher(1),Turtle tamer(1)	8	6,8	Sculptor (1), Pottery master(1)	2	4,4
As “related to life”	Life(2), Family(1), Face with life(1), Law(1), System(1), Preparation for life(1), Platonic love(1), Seasons(1), Human(1), Love(1), Mother(1), Recipe(1), Nervous, Anger(1), Chinese torture(1), Organ(1), Fruit trees(1), Branched tree(2), Sun(1), Empty brain(1), Our fingers(1), Plant(1)	23	19,7	Exams as SBS, LYS (1), System that unchanging outcomes(1), Computer program(1), Ineffective element(1), Survivor(1), Traffic signs(1), Newly planted seedings(1), Planted seed(1)	8	17,8
Total		117	100		45	100

Category 1: Teacher Education Programs as “Action”

In this category, there are 27 metaphors including 20 from pre-service science teachers and 7 from pre-service mathematics teachers. In category, at most, metaphors such as make a food (6) ve raise trees (2) were used. "Raiser trees" metaphor seems to be common at the departments. The following are some examples of metaphors:

“...similar to educating child. When we came to the university we did not have information about teaching as children who do not know the new world. As children grow up and stand on their own feet obtain information about the world, we have learned through the program as a teacher.”

“...similar to rowing on the lake. It likes to try getting way in a certain limit. It is certain where you go, but it is limited what you can do. Vain effort labored in vain.”

Category 2: Teacher Education Programs as “Tool/ Material”

In this category, there are 41 metaphors including 29 from pre-service science teachers and 12 from pre-service mathematics teachers. In category, at most, metaphors such as book (10), computer (3), encyclopedia (3), vaccine (2), and passenger bus (2) were used. Metaphors such as "encyclopedia, vaccine” seems to be common at the departments. The following are some examples of metaphors:

“...similar to made in China products. These products are imitation of quality products and are suitable. This attractive comes. But after a while, you know it is useless. Teacher education programs are the same. It is a copy of the west. Convenient will be shown with minor changes.”

“...similar to passenger bus. Bus is education program. Money is information. Driver is a student. People are teachers.”

Category 3: Teacher Education Programs as “Environment”

In this category, there are 53 metaphors including 37 from pre-service science teachers and 16 from pre-service mathematics teachers. This category is concerning maximum metaphors. In category, at most, metaphors such as factory (11), kitchen (2), hospital (2), library (2), construction (2), and potter’s workshop (2) were used. It was seen that metaphors such as “factory, kitchen and hospital” common at the departments. The following are some examples of metaphors:

“...similar to factory. Factory undergone various processes by taking the different materials from nature and makes it useful. While training, we will enter this teacher education program.”

“...similar to forest. There are many live in the forest. Lack of one of them will derange. Program, so it is the same. If without one of the courses that comprise the requirements for the teaching profession is incomplete or delays.”

Category 4: Teacher Education Programs as “Person Have a Profession”

In this category, there are 10 metaphors including 8 from pre-service science teachers and 2 from pre-service mathematics teachers. This category is concerning minimum metaphors. In category, at most, metaphor sculptor (4) was used. The following are some examples of metaphors:

“...similar to sculptor. Program the same as a sculptor, gives us the shape. -Shape of teacher-”

“...similar to cook. There are a lot of ingredients in the kitchen at the restaurant. Cook chooses from these materials that are needed and does dishes. Teacher education program required for teaching in the selects and presents us.”

Category 5: Teacher Education Programs as “Related to Life”

In this category, there are 31 metaphors including 23 from pre-service science teachers and 8 from pre-service mathematics teachers. In category, at most, metaphors such as life (2), branched trees (2) were used. Common metaphor which is used by teacher candidates doesn’t have. The following are some examples of metaphors:

“...similar to platonic love. You do not get the teacher education program needed for teaching. We came as high expectations, but the program can not response to me was for teaching.”

“...similar to Chinese torture. Teacher education programs involves taking force things that are not relevant in teaching. We are trying very hard to 5-minute presentations. But even worse is that they will not do any of my teachers in my life.

CONCLUSION

Considering the responses of teacher candidates, especially metaphors and examples of common answers, the positive and negative aspects of the program are emerging. If teacher how perceive teacher education program applied as become to teacher, they will create a profile in the minds of teacher in that direction. Therefore, in the light of the findings for the thoughts and perceptions of teacher candidates about the results of the program can be summarized as follows:

1. It was seen that both science teacher and mathematics teacher candidates thought teacher education programs as “an environment” at most. Metaphor most frequently used under environment category is the factory.
2. It was seen that both science teacher and mathematics teacher candidates thought teacher education programs as “person have a profession” at least.
3. Metaphors such as raise trees, encyclopedia, vaccine, factory, kitchen, hospital, and sculptor are common in both departments.
4. Although 37 metaphors are negative as content, 15 metaphors are positive and 110 metaphors are neutral. Thus, it can be said that teacher candidates’ opinions will change with mutual relations. Because, in the 110 methaphor which are neutral, when installing analogy relations, bilateral relations

arising from the positive and negative sides have been talking about. If teachers offer students good research results, will form a good product or vice versa.

RECOMMENDATIONS

At the end of the study, the following suggestions may be submitted:

1. Metaphors for teacher training programs are examined deeply as the common metaphors can be examined by applying teacher candidates in the different departments.
2. Examining the perceptions of prospective teachers towards the program, may be provided the revision of teacher education programs.

REFERENCES

- Akkaya, A. (2011). Perceptions of 8th Grade Elementary Students about Speaking Concepts. *Adiyaman University Journal of Social Science Institute*, 4(7), 1-9.
- Ates, M., Karatepe, A. (2013-a). The Analysis of University Students' Perceptions Towards "Environment" Concept with the Help of Metaphors. *International Journal of Social Science*, 6(2), 1327-1348.
- Ates, M., Karatepe, A. (2013-b). The Analysis of University Students' Perceptions Towards "Global Warming" Concept with the Help of Metaphors. *Journal of Marmara Geography*, 27, 221-241.
- Aydın, F. (2010). Metaphors of Secondary School Students on Geography Concept. *Educational Sciences: Theory & Practice*, 10(3), 1293-1322.
- Carter, K. (2001). Meaning And Metaphor: Case Knowledge in Teaching. *Theory Into Practice*, (29): 109-115
- Cekmez, E., Yildiz, C., Bütüner, S.O.(2012). Phenomenographic Research Method. *Necatibey Education Faculty Journal of Electronic Science and Mathematics Education*, 6(2), 77-102.
- Demirci Güler, M.P.(2012). Metaphorical Definitions of Classroom Teacher Candidates about Science and Technology Courses. *Electronic Journal of Social Sciences*, 11(41), 53-63.
- Dundar, H., Karaca, E. T.(2013). Pedagogical Formation Students' Conceptual Metaphors about Pedagogical Formation Program. *Gazi University Journal of Industrial Arts Education Faculty*, 30, 19-34.
- Karacanta, H (2013). University Students' Conceptual Metaphors about National Value. *Gazi University Journal of Industrial Arts Education Faculty*, 32, 107-114.
- Shuell, T. J. (1990). Teaching And Learning As Problem Solving. *Theory into Practice*, 29(2): 102-108.
- Türk Dil Kurumu(2008). Metafor. *Türk Dil Kurumu sözlüğü*. Retrieved from <http://tdkterim.gov.tr/seslisözlük/?kategori=yazimay&kelimesec=045094.July12.2008>.
- <http://www.msxlab.org/forum/soru-cevap/209814-milli-degerlerimiznelerdir.html#ixzz2f9hfgqJ3>
- Türkeli Sandır, Y. (2006). Phenomenographic Study on Teacher Candidates' Opinions on The Function Concept. Unpublished Master's Thesis, Gazi University, Education Science Institute, Ankara.
- Tringwell, K. (2000). Phenomonography: Variation and Discernment. In C. Rust (Ed.), *Improving Student Learning*. Proceeding of the 1999 7th International Symposium (pp. 75-85). Oxford, UK: Oxford Centre for Staff and Learning Development.

DETERMINATION OF STUDENT TEACHERS' VIEWS ABOUT REACT STRATEGY

Neslihan ÜLTAY
Giresun University
neslihanultay@gmail.com

Ümmü Gülsüm DURUKAN
Giresun University
u.g.iyibil@gmail.com

Eser ÜLTAY
Giresun University
eserultay@gmail.com

ABSTRACT: The purpose of this study is to determine student teachers' views about REACT strategy. In the study, data gathered quantitatively by the clinical interviews in the academic year of 2012-2013 at the spring term. The clinical interviews were carried out with 11 student teachers from two different classes in elementary education department. In both classes, REACT strategy was used as a teaching method by the same researcher in General Chemistry Course. In the clinical interviews, students were asked that "What are your favorite aspects of the teaching method?", "What are the aspects that you do not like about the teaching method?", "What stage of the teaching method do you like most?", "What conveniences does the teaching method provide for your understanding of the topic?", and "What do you suggest about the teaching method?". The findings suggest that student teachers liked performing experiments at most, facilitating learning and making the topic concrete. Most of student teachers did not suggest anything for REACT strategy as a pitfall, a small number of student teachers complained about an increase in students responsibility, e.g. early class preparation and overcrowding classes. As a conclusion, it can be said that student teachers liked REACT strategy because it facilitates learning by providing science experiments.

Key words: REACT strategy, student teachers, context-based approach

INTRODUCTION

Context-based approach, which becomes popular in recent days, aims at constructing connections between the context of real life issues and content. Context-based courses do not only make students active but also offers hope for improving students' engagement in learning chemistry and perceiving relevance of chemistry (Bennett, Gräsel, Parchmann & Waddington, 2005; King, 2007). As described by Gilbert (2006), the context-based approach is application oriented within the cases, scenarios from students on going lives outside of the classroom, thus application strategy helps students to construct knowledge rather than memorization of knowledge. Additionally, the context-based approach helps to contribute to students' lives or the lives of others around the world and helps them to acquire a better understanding of natural environment (Bennett & Lubben, 2006; Ültay & Ültay, 2012). Thus, participants can answer the question: "Why do I need to learn this?" and the context based learning can respond to this by linking theoretical knowledge with real world (Demircioğlu, Demircioğlu & Çalık, 2009; Ültay & Çalık, 2012). Bennett et al. (2005) pointed out that in the context-based courses, contexts are the starting points in order to develop scientific understanding.

To get more engagement of students and to develop more interest in science are the goals of context-based approach (Fensham, 2009). Looking at the literature on the effect of context-based science instruction, it is seen that some of the studies indicate increase in academic success (Acar & Yaman, 2011; Demircioğlu, 2008; Ingram, 2003; Schwartz-Bloom & Halpin, 2003) and positive effect on students' attitudes and motivation (Ingram, 2003; Belt, Leisvik, Hyde & Overton, 2005; Bennett & Lubben, 2006; Campbell, Lubben & Dlamini, 2000; Barker & Millar, 2000). To implement the context-based approach to the learning-teaching process, one of the strategies is REACT strategy (Crawford, 2001). In REACT strategy five essential forms of learning can be defined as: Relating, Experiencing, Applying, Cooperating and Transferring. At "Relating" stage the new information is related to everyday situations. At "Experiencing" stage points out learning in the context of exploration, discovery and invention. The aim is to allow students to experience activities that are directly related to real-life work. At "Applying" stage students apply concepts and information in a useful context through projects, activities, labs, text, and video. The "Cooperating" stage points out learning in the context of

sharing, responding and communicating with other learners. This can be actualizes via group activities such as projects, labs, problem-solving, realistic scenarios. At “Transferring” stage students transfer skills and knowledge from one setting to another (CORD, 1999). Ingram (2003) described the REACT strategy as grounding on the bases of the constructivism, in which student involve in critical thinking and problems solving activities in order to improve students’ understanding of concepts.

Taking into consideration the literature, it is seen that the context-based chemistry education not only improves students’ motivation (Bennett et al. 2005; Belt et al. 2005; Bulte et al. 2005; King, Bellocchi and Ritchie, 2008; Pilling and Waddington 2005) but also increases their enthusiasm towards the subject (Ramsden 1992) and positively changes students’ attitudes towards chemistry (Demircioğlu et al. 2009; Dlamini and Lubben 1996). Starting from this point, the purpose of this study is to determine student teachers’ views about REACT strategy which is an implementation form of context-based approach in the classroom.

The Research Question

In the current study, the research question is stated as “What do student teachers think about the effectiveness of the teaching method namely REACT strategy?”

METHODS

In the study, data gathered quantitatively by the clinical interviews in the academic year of 2012-2013 spring term. Clinical interviews were carried out with 11 student teachers (aged 17-20 years) from two different classes in elementary education department. In both classes, REACT strategy was used as a teaching method by the same researcher in General Chemistry Course during 2 weeks. Classes were coded as E and C. Students in class E were labeled as E1, ... and E5, students in class C were labeled as C1, ... C6. Five students from class E and six students from class C were participated in the interview. Voluntarism was taken as a basis in the interview and firstly it was planned that five voluntary students from each class would have been selected but in class C, six students wanted to participate in the interview.

In the clinical interview, three questions were asked to the students. Two science education experts controlled the questions readability and understandability. Questions are given in Table 1. Interviews were tape recorded and lasted for 10-15 minutes. The transcriptions of the interview data were made by one of the researchers. She classified the results into the similar categories and themes. After that, rest of the researchers controlled the themes and necessary changes were made in the themes.

RESULTS AND FINDINGS

To determine the student teachers’ views about REACT strategy, clinical interviews were carried out and data obtained from the interviews are shown in Table 1.

Table 1. Findings of Clinical Interview

Question	Themes	Class E		Class C	
		Students	f	Students	f
1. A) What are your favorite aspects of the teaching method?	Performing experiments	E1, E4, E5	3	C2	1
	Making observations	E1	1	-	-
	Facilitating teaching	E2	1	C5	1
	Making the topic more concrete	E2, E5	2	C4, C6	2
	Making individual activities	E4	1	C5	1
	Enjoyable or funny learning environment	-	-	C1, C6	2
B) What are the aspects that you	No pitfall in the teaching method	E1, E2, E5	3	C4, C5, C6	3

do not like about the teaching method?	An increase in students responsibility, e.g. early class preparation	E5	1	-	-
	Anxious about the exam	E4	1	-	-
	Leeway in the laboratory	-	-	C1	1
	Overcrowding of classes	E4	1	C2, C3	2
C) What stage of the teaching method do you like most?	Performing experiments	E1, E2, E4, E5	4	C2, C4, C5, C6	4
	Learning environment	-	-	C1	1
	Being good of all stages	-	-	C6	1
2. What conveniences does the teaching method provide for your understanding of the topic?	Permanency	E1, E2, E5	3	C4, C6	2
	Providing awareness in daily life	E4	1	C4	1
	Facilitating teaching	-	-	C2, C4, C5, C6	4
3. What do you suggest about the teaching method?	No suggestion	E2, E3, E4, E5	4	C3, C4, C5, C6	4
	Making all the classes in the laboratory	E1	1	C1, C2	2

According to Table 1, in the first question three sub-questions were asked students. In 1A question, student teachers' were asked the favorite aspects of the teaching method. In Class E, three student teachers found "performing experiments" and two student teachers found "making the topic more concrete" as favorite aspects of the method. In Class C, two student teachers stated that "making the topic more concrete" and "enjoyable or funny learning environment" were the favorite aspects of the teaching methods. In 1B question, student teachers were asked about the aspects that they did not like about the teaching method. In both classes, three student teachers from each stated that "there was no pitfall in the teaching method". However, one student teacher complained about "early class preparation", one student teacher complained about "the overcrowding of the class" and "anxious about the exam" in Class E. Also, two student teachers found the classes overcrowding and one student teacher did not like "the leeway in the laboratory" during the experiments in Class C. Meanwhile, four student teachers from each class liked "performing experiments" mostly. One student teacher liked "learning environment" and one liked "being good of all stages" mostly in Class C.

In the second question, it was asked student teachers that "what conveniences does the teaching method provide for your understanding of the topic?". Three student teachers from Class E said "permanency" while two student teachers said the same thing in Class C. Four student teachers stated that the teaching method "facilitated learning".

In the last question, suggestions for the teaching method were asked for the student teachers and four student teachers from each class did not "suggest anything". One student teacher from Class E and two from Class C suggested "making all the classes in the laboratory".

When the findings are considered, student teachers found REACT strategy effective because they stated that they liked performing experiments and daily life examples and materials helped them to make the topic more concrete (Ültay N, 2012). In context-based chemistry education the students are able to become more actively involved in their own learning processes (Stolk et al. 2009), so they will be more willing to learn. Also, their motivation affected positively and they enjoyed the classes. REACT strategy affects students' motivation and attitudes towards the course (Saka, 2011; Ültay N, 2012). Additionally REACT strategy contributed to get a more positive learning environment (Crawford, 2001; Coştu, 2009). In the current study, student teachers

asserted that they learned the topics more permanent. Because some parts of REACT strategy enabled hands-on activities, student teachers had an opportunity to see some abstract knowledge more concrete. Therefore, their learning became more meaningful and permanent. Context-based chemistry education facilitates students' learning by linking chemistry to daily lives (Ültay and Çalık, 2012; TPSI, 1991) In context-based approach contexts that are the starting points for the development of scientific understanding (Bennett et al., 2005) are introduced to the students in order to excite their curiosity (Stolk et al., 2009).

Despite all these positive thoughts and feelings towards REACT strategy, some student teachers did not give up exam anxious. In Turkish educational system, because there are a lot of exams, student teachers hoped teachers make traditional teaching, i.e teacher writes on the board and students memorize the facts. But REACT strategy is based on context-based approach which takes students involvement and meaningful contexts as basis (Pilot and Bulte, 2006), some student teachers complained about what to do in the exam. For this negative point in REACT strategy, an explanation stage was suggested especially for Turkish educational context (Coştu, 2009; E. Ültay, 2012; N. Ültay, 2012).

CONCLUSION

The research findings reported here suggest that student teachers liked REACT strategy in the learning environment and the strategy facilitated their learning by the hands-on activities and daily life examples. Student teachers' attitudes and interest were also affected positively and this helped them to construct coherent mental maps about the topic. Despite the positive feelings, some student teachers felt the absence of explanation part of the strategy. For Turkish educational context, an explanation step can be added as an extra part or to all steps of the strategy. There is need to new studies about searching the effectiveness of REACT strategy in the literature.

REFERENCES

- Acar, B. & Yaman, M. (2011). Bağlam Temelli Öğrenmenin Öğrencilerin İlgi ve Bilgi Düzeylerine Etkisi. *Hacettepe Üniversitesi Eğitim Fakültesi Dergisi*, 40, 1-10.
- Barker, V. & Millar, R. (2000). Students' Reasoning about Basic Chemical Thermodynamics and Chemical Bonding: What Changes Occur During a Context-Based Post-16 Chemistry Course? *International Journal of Science Education*, 22, 1171-1200.
- Belt, S. T., Leisvik, M. J., Hyde, A. J. & Overton, T. L. (2005). Using a Context-Based Approach to Undergraduate Chemistry Teaching – A Case Study for Introductory Physical Chemistry. *Chemistry Education Research and Practice*, 6(3), 166-179.
- Bennett, J., Gräsel, C., Parchmann, I. & Waddington, D. (2005). Context-based and Conventional Approaches to Teaching Chemistry: Comparing teachers' views. *International Journal of Science Education*, 27(13), 1521-1547.
- Bennett, J. & Lubben, F. (2006). Context-based Chemistry: The Salters approach. *International Journal of Science Education*, 28(9), 999-1015.
- Campbell, B., Lubben, F., & Dlamini, Z. (2000). Learning Science through Contexts: Helping Pupils Make Sense of Everyday Situations. *International Journal of Science Education*, 22, 239-252.
- CORD, (1999). Teaching Science Contextually, CORD Communications, Inc., Waco, Texas, USA.
- Coştu, S. (2009). Matematik Öğretiminde Bağlamsal Öğrenme ve Öğretme Yaklaşımına Göre Tasarlanan Öğrenme Ortamlarında Öğretmen Deneyimleri. Yüksek Lisans Tezi, Karadeniz Teknik Üniversitesi, Fen Bilimleri Enstitüsü, Trabzon.
- Crawford, M. L. (2001). Teaching Contextually: Research, Rationale, and Techniques for Improving Student Motivation and Achievement in Mathematics and Science, CCI Publishing, Waco, Texas.
- Demircioğlu, H. (2008). İçeriğe Dayalı Yaklaşımın Sınıf Öğretmeni Adaylarının Maddenin Halleri Konusuna Yönelik Başarıları Üzerine Etkisi, Doktora Tezi, Karadeniz Teknik Üniversitesi, Fen Bilimleri Enstitüsü, Trabzon.
- Demircioğlu, H., Demircioğlu, G. & Çalık, M. (2009). Investigating the effectiveness of storylines embedded within a context-based approach: the case for the Periodic Table. *Chemistry Education Research and Practice*, 10, 241-249.
- Dlamini, B. & Lubben, F. (1996). Liked and Disliked Learning Activities: Responses of Swazi Students to Science Materials with a Technological Approach. *Research in Science and Technological Education*, 14(2), 221-236.
- Fensham, P. (2009). Real world contexts in PISA science: implications for context-based science education. *Journal of Research in Science Teaching*, 884-896.

- Gilbert, J. K. (2006). On the Nature of “Context” in Chemical Education. *International Journal of Science Education*, 28(9), 957-976.
- Ingram, S. J. (2003). The effects of contextual learning instruction on science achievement male and female tenth grade students, Ph.D., University, South of Alabama, USA.
- King, D. (2007). Teacher beliefs and constraints in implementing a context-based approach in chemistry. *Teaching Science*, 53(1), 14-18.
- King, D., Bellocchi, A. & Ritchie, S. M. (2008). Making Connections: Learning and Teaching Chemistry in Context, *Research Science in Education*, 38, 365-384.
- Pilling, G. M. & Waddington, D. J. (2005). Implementation of Large-Scale Science Curricula: A Study in Seven European Countries. *Journal of Science Education and Technology*, 14(4), 393-407.
- Pilot, A. & Bulte, A. M. W. (2006). Why do you “need to know”? Context-based education. *International Journal of Science Education*, 28(9), 953–956.
- Ramsden, J. (1992). If it’s Enjoyable, Is It Science? *School Science Review*, 73, 65–71.
- Saka, A. Z. (2011). Investigation of Student-Centered Teaching Applications of Physics Student Teachers. *Eurasian J. Phys. Chem. Educ., Jan* (Special Issue), 51-58 retrieved April 10, 2014.
- Schwartz-Bloom, R.D. & Halpin, M.J. (2003). Integration of pharmacology topics into high school biology and chemistry classes improves student performance. *Journal of Research in Science Teaching*, 40, 922-938.
- Stolk, M.J., Bulte, A. M. W., de Jong, O. & Pilot, A. (2009). Towards a framework for a professional development programme: empowering teachers for context-based chemistry education. *Chemistry Education Research and Practice*, 10, 164–175.
- The Physical Sciences Initiative (TPSI) (1991). Social and applied aspects; what is meant by “social and applied”? www.psi-net.org/chemistry/s1/socialandapplied.pdf
- Ültay, E. (2012). Implementing REACT Strategy in a Context-Based Physics Class: Impulse and Momentum Example. *Energy Education Science and Technology Part B: Social and Educational Studies*, 4(1), 233-240.
- Ültay, N. (2012). Designing, Implementing and comparing “acids and bases” instructional tasks based on REACT strategy and 5E model. Unpublished PhD Thesis, Karadeniz Technical University, Trabzon, TURKEY.
- Ültay, N. & Çalık, M. (2012). A Thematic Review of Studies into the Effectiveness of Context-Based Chemistry Curricula. *Journal of Science Education and Technology*, 21(6), 686-701.
- Ültay, E. & Ültay, N. (2012). Designing, implementing and evaluating a context-based instructional materials on buoyancy force. *Energy Education Science and Technology Part B: Social and Educational Studies, Special issue-1*, 385-394.

FEN BİLGİSİ ÖĞRETMEN ADAYLARININ GELİŞTİRDİKLERİ BENZEŞİMLER (ANALOJİLER) ÜZERİNE BİR ARAŞTIRMA

INVESTIGATION OF PRE-SERVICE SCIENCE TEACHERS' GENERATED RESEMBLANCE (ANALOGY)

Prof. Dr. Ahmet AFYON
Necmettin Erbakan Üniversitesi, Ahmet Keleşoğlu Eğitim Fakültesi
aafyon42@gmail.com

Arş. Gör. Azize DİGİLLİ
Düzce Üniversitesi, Eğitim Fakültesi
azizedigilli@windowslive.com

ÖZET: Bu çalışmanın temel amacı, fen bilgisi öğretmen adaylarının fen bilimleri konularına ilişkin geliştirdikleri analogileri, Fen Bilimleri Öğretim Programı'nda yer alan öğrenme alanlarını ve analogilerin yapı ve çeşitlerini dikkate alarak incelemektir. Araştırmada veri toplama süreci 2013-2014 öğretim yılı güz döneminde gerçekleştirilmiştir. Araştırmaya Necmettin Erbakan Üniversitesi Ahmet Keleşoğlu Eğitim Fakültesi Fen Bilgisi Öğretmenliği Anabilim Dalı'nın 3 ve 4. Sınıfında öğrenim gören 286 (3. Sınıf=147, 4.Sınıf=139) öğretmen adayı katılmıştır. Anketin boş bırakılması ya da öğretmen adaylarının analogik ifadelerinin uygun olmaması sebebiyle 63 öğretmen adayının verileri analiz edilmemiştir. Bu yüzden araştırmada 223 öğretmen adayının verisi analiz edilmiştir. Öğretmen adaylarının fen kavramları ile ilgili geliştirdikleri analogileri belirlemek için verilerin analizinde içerik analizi kullanılmıştır. Verilerin analizi sonucunda; öğretmen adaylarının Fen Bilimleri Öğretim Programı'ndaki dört farklı öğrenme alanında da analogi geliştirdikleri bulunmuştur. Fakat öğretmen adaylarının en çok "Canlılar ve Hayat" öğrenme alanından analogi oluşturduğu tespit edilmiştir. Ayrıca araştırmada, geliştirilen analogilerin yapı ve çeşitlerine göre en fazla fonksiyonel analogi, sözel analogi, somut-soyut analogi ve basit analogiler olduğu tespit edilmiştir. Tüm bunlara ilaveten, strateji tanımı olan ve sınırlılıklarının belirtildiği analogiler olduğu bulunmuştur. Sonuç olarak, fen bilgisi öğretmen adaylarının fen konularına ilişkin geliştirdikleri analogilerin yapı ve çeşitlilik bakımından ve hedef kavramın içeriği bakımından sınırlı olduğu bu çeşitliliğin sağlanması için farklı uygulamaların yapılması gerektiği düşünülebilir.

Anahtar Kelimeler: Analogi, Fen Bilgisi Öğretmen Adayları, Fen Eğitimi

ABSTRACT: The core purpose of this study is to examine the analogies related to science concepts developed by the pre-service science teachers and to examine these analogies taking into consideration the kinds of learning areas located in Science Education Program in terms of the structure and types of analogies. The data was collected during fall semester of 2013-2014 academic years. The sample of the study constituted 286 pre-service science teachers enrolled in third and fourth grades of Elementary Science Education Department of University of Necmettin Erbakan, Ahmet Keleşoğlu Faculty of Education (3rd=147, 4th=139). Because of the fact that survey was leaved empty or pre-service science teachers' analogical expressions were unsuitable, 63 pre-service science teachers' data was not analyzed. Therefore, 223 pre-service science teachers' data was analyzed for this study. Data regarding analogies was analyzed by using content analysis. Results revealed that pre-service science teachers developed analogies in Science Education Program in four different learning areas. It is found that pre-service science teachers developed analogies mostly in "live and life" learning area. It is also revealed that in terms of the types of the analogies pre-service science teachers developed mostly functional, verbal, concrete-abstract and simple analogy. In addition to all these, it is also found strategy identification and the limitations of the analogy. As a result, pre-service science teachers' analogies are limited in terms of their target concept's content and the structure and type. To supply this diversity, different applications should be conducted.

Keywords: Analogy, Pre-service Science Teacher, Science Education

NOT: Bu çalışma "Fen Bilgisi Öğretmen Adaylarının Geliştirdikleri Benzeşimler (Analogiler) Üzerine Bir Araştırma" başlıklı yüksek lisans tezimin özetidir.

IN-SERVICE SCIENCE TEACHER PROFILES FROM THE EYES OF PRE-SERVICE SCIENCE TEACHERS: WHAT DID THEY OBSERVE?

Dekant Kıran
Middle East Technical University
dkiran@metu.edu.tr

Mehmet Şen
Middle East Technical University
msen@metu.edu.tr

The purpose of this study is to portray in-class implementations of in-service science teachers from the eyes of the pre-service science teachers. Specifically, this study examines various science teaching components such as overcoming misconceptions, assessment of science learning, integrating nature of science aspects, using different science teaching methods etc. that science teachers use during instruction. Additionally, classroom management strategies of science teachers are also included. The data are obtained from the observations of pre-service science teachers. Thirty three pre-service and thirteen in-service teachers participated in the study. The observation protocols that pre-service science teachers filled will be analyzed to document the findings. A content analysis approach and descriptive statistics were used for the data analysis. The data revealed that science teachers have low levels of PCK and they generally use traditional teaching methods, strategies and traditional assessment techniques. Their NOS understandings are limited and classroom management strategies rely on discipline.

Key words: Pre-service science teachers, in-service science teachers, practice teaching course, science teaching

INTRODUCTION

Research on PCK has been common in science education since 20 years (Abell, 2008). The term was proposed by Shulman (1986, 1987) that is special mixture of pedagogical knowledge and content knowledge where none of these two components are sufficient to be a good teacher. Therefore, it is very important to teach any specific topic by use of suitable teaching strategies and assessment techniques. Shulman (1986) also claimed that students' understandings should be cared by the teacher where teachers transform their academic science knowledge into school science.

After Shulman claimed his ideas about teaching, others proposed different explanations for their PCK views (Grossman, 1990; Cochran et al. 1993; Magnusson et al. 1999; Veal & MaKinster, 1998). Kind (2009) reported that different theoretical explanations for PCK can be categorized by two different main models in terms of transformative models and integrative models. Transformative models claim that content knowledge and PCK are different knowledge domains. According to transformative models there is a mechanism that teachers transform their content knowledge into PCK. On the other hand, integrative models see content knowledge as part of PCK. Integrative models are lack of explaining the mechanism for PCK formation. According to integrative models, PCK develops by experience.

One of the most used PCK model is the Magnusson et.al (1999) PCK model. This model was inspired by Grossman (1990) study. According to this model, PCK has five different components in terms of orientation towards science teaching, knowledge of curriculum, knowledge of learner, knowledge of assessment, and knowledge of instructional strategies. Orientation towards science is about beliefs and attitudes towards science and this component shapes and controls other PCK components.

Due to fact that PCK develops with experience and it is a dynamic knowledge domain (Abell, 2008; Aydın & Boz, 2012) pre-service teachers have little or no PCK. However, most of the PCK studies were conducted with pre-service teachers too. On the other hand, number of the PCK studies that use in-service teachers as sample were less than studies examining pre-service teachers' PCK. Comparing with pre-service teachers, in-service teachers have better PCK because of their experience.

Teacher PCK was generally little according to previous studies, therefore science educators developed tools such as content representation tools and managed professional development programs in order to increase

science teachers' PCK. Professional development studies which last long term were found successful in literature.

Content knowledge and PCK are also investigated by researchers. Researchers examined the relationship between these different knowledge domains. Content knowledge has two subcomponents in terms of substantive knowledge and syntactic knowledge. Substantive knowledge is related with theories, principles, concepts and their relationship with each other. On the other hand, syntactic knowledge is related with how the scientific knowledge is gained and developed and characteristics of knowledge. Syntactic knowledge refers to nature of science (Khalick et al., 1997). Studies found different results from each other both for the relationship between substantive knowledge and PCK and syntactic knowledge and PCK. Some researchers claimed that there is a positive relationship between content knowledge and PCK, some others found blurred relationship between content knowledge and PCK, and some science educators found no relationship between content knowledge and PCK as reported in Kind (2009) study.

Finally, researchers examined the interaction between PCK components. For example, Hanuscin et al. (2010) found that teacher knowledge of learner is affected by knowledge of assessment because better assessment let teachers to understand difficult points of students' understandings. In addition, knowledge of learner affects teacher knowledge of instructional strategies directly. When teachers know students' needs better, they prefer appropriate teaching strategies for selected topic. This result showed that teachers' PCK components are closely related with each other and researchers suggested studying all components of PCK instead of focusing of only one or some components of PCK.

In line with the related literature, the aim of this study is to portray in-class implementations of in-service science teachers from the eyes of the pre-service science teachers. Specifically, this study examines various science teaching components such as overcoming misconceptions, assessment of science learning, integrating nature of science aspects, using different science teaching methods etc. that science teachers use during instruction. Additionally, classroom management strategies of science teachers are also included.

METHOD

This study is a qualitative study in nature. In order to get detailed information about the in-class implications of science teachers, pre-service science teachers have made observations during their practice teaching course. In this course, they observe mentor teachers and make several presentations throughout the semester. For the purpose of this study, they were provided with observation protocols before they go to schools for observations. Thirty three pre-service and thirteen in-service teachers participated in the study. The observation protocols that pre-service science teachers filled were analyzed to document the findings. A content analysis approach and descriptive statistics were used for the data analysis.

Data Analysis Procedure

The data is gathered from the answers of pre-service science teachers to the questions of observation protocol. Then related codes and categories were formed depending on the PCK studies found in literature. The observation protocol includes questions about science teaching orientation, knowledge of curriculum, knowledge of learner, knowledge of assessment, knowledge of instructional strategies. In addition, science teachers integrating nature of science aspects and classroom management strategies are examined.

RESULTS AND FINDINGS

Results of the study showed that 84 % of the teachers preferred teacher centered orientation to science teaching such as didactic and academic rigor. Only 24 % of teachers adopted constructivist orientation such as guided inquiry. Teachers were successful for understanding of their students' prior knowledge and misconceptions. 54 % of participants both mentioned students' prior knowledge and identified their misconceptions. On the other hand, 32 % of the participants didn't talk about student's prior knowledge and their misconceptions. Teachers were generally informed about knowledge of curriculum. For example; 42 % of them covered the objectives related with STS, SPS and content knowledge. Similarly, 42 % of the participants noted SPS and content knowledge objectives in their teaching. Another aim of this study is to understand whether teachers integrate NOS into their teaching. Findings showed that teachers either don't mention NOS by 45 % or mentioned only one or two aspects of NOS such as tentativeness, theory laden or cultural embeddedness of NOS. Teachers' teaching strategies were found parallel to their orientation towards science all of the teachers in this study preferred direct instruction and questioning. In addition, 54 % of them used experimenting and 22 % of teachers

used demonstration. Few of the participants used contemporary teaching strategies such as inquiry (8 %), cooperative learning (8 %), analogy (8 %), project based learning (8 %). As their assessment techniques, teachers either didn't assess their students (38 %) or used traditional assessment techniques such as giving homework to students (62 %), making quizzes (15 %). On the other hand only few of the teachers used alternative assessment techniques correspondingly concept mapping (8 %), performance based assessment (8 %). Contextual knowledge is another aspect of this study. Pre-service teachers reported that their mentor teachers usually were not aware of the school environment, students need in and out of school as contextual knowledge. Only 42 % of the teachers were informed about the contextual factors such as school and students' parents. Final aspect of our study was based on how teachers manage their classrooms. Result of this study showed that 85 % of the teachers used strict rules for classroom management as disciplinary teachers. Moreover, 27 % of the teachers used their gestures to manage their classes. On the other hand only 30 % of the teachers were friendly towards their students to manage their classes.

CONCLUSIONS

This study aimed to portray the in-class implementations of science teachers. By examining the components of PCK it was aimed to present the current situation in terms of teaching science. In conclusion, this study showed that teachers were insufficient for their PCK in general depending on their orientation towards science, knowledge of curriculum, knowledge of assessment and knowledge of instructional strategies. In addition, these teachers were not successful to transform their NOS views into their teaching. Teachers' contextual knowledge and classroom management skills were also found inadequate depending on the views of pre-service teachers.

RECOMMENDATIONS

According to the finding of the study participating science teachers have little PCK. Therefore, programs that can develop their PCK may be beneficial. Additionally, workshops and end-of-semester seminars may be designed to foster their PCK. In terms of their classroom management strategies, teachers generally prefer to use traditional techniques. Seminars related to motivation may be useful to make teachers alter their discipline approach to motivating to learn science.

REFERENCES

- Abell, S.K. (2008). Twenty years later: Does pedagogical content knowledge remain a useful idea? *International Journal of Science Education*, 30(10), 1405-1416.
- Aydin, S., & Boz, Y. (2012). Review of studies related to pedagogical content knowledge in the context of science teacher education: Turkish case, *Educational Sciences: Theory and Practice*, 12(1), 497-505.
- Cochran, K.F., DeRuiter, J.A., & King, R.A. (1993). Pedagogical content knowing: An integrative model for teacher preparation. *Journal of Teacher Education*, 44(4), 263-272
- Grossman, P. (1990). *The Making of a Teacher*. New York: Teacher College Press.
- Kind, V. (2009). Pedagogical Content Knowledge in Science Education: potential and perspectives for progress. *Studies in Science Education*, 45 (2), 169-204.
- Hanuscin, D. L., Lee, M. H., & Akerson, V. L. (2010). Elementary teachers' pedagogical content knowledge for teaching the nature of science. *Science Teacher Education*, 145-167.
- Khalick, F.A., & BouJaoude, S. (1997). An explanatory study of the knowledge base for science teaching. *Journal of Research in Science Education*, 34(7), 673-699.
- Magnusson, S.J., Borko, H., & Krajcik, J.S. (1999). Nature, source, and development of pedagogical content knowledge for science teaching. In J. Gess- Newsome & N. Lederman (Eds.), *Examining Pedagogical content Knowledge* (pp.95-132). Boston, MA: Kluwer Press.
- Veal, W.R. & Makinster, J.G. (1998). Pedagogical content knowledge taxonomies *Electronic Journal of Science Education* available at <http://unr.edu/homepage/crowther/ejse/vealmak.html> (accessed 31.01.2014)

STUDENTS' TALK DURING COLLABORATIVE GROUP DISCUSSION

Mustafa CANSIZ
Artvin Çoruh University
mustafacansiz@gmail.com

Nurcan CANSIZ
Atatürk University
nurcansiz7911@gmail.com

ABSTRACT: This study aimed to explore the types of talk occurring in small group discussions about digestive system. Twenty two seven-graders worked on digestive system in small groups. In order to study these particular group's interactions and how they constructed meaning as they discussed digestion, field notes, transcripts of small-group discussions and group interviews were analyzed qualitatively. The results revealed that three types of talk (exploratory, cumulative and disputational) were observed in each group in varying amounts. The comparative analysis among groups revealed that students' engaged in exploratory talk showed explicit and more sound reasoning than students' engaged in disputational or cumulative talk. The potential factors which may lead to reasoning were also explored.

INTRODUCTION

“Language is, historically and individually, the foundation of being human. And talk—direct exchange between humans who can attribute intentionality and understanding to each other—is the foundational act of language” (Resnick, Michaels, & O'Connor, 2010, p.163). Resnick et al. further stated that “without talk, minds can neither grow nor become disciplined. Without disciplined talk, scientific, mathematical, and humanistic knowledge remains static and unused” (p.163). From ancient times to present, human beings tried to understand the world, communicate with others, shared ideas, emotions, and wishes through language and talk. Dialogue and talk are inevitable in our daily lives as in classroom environments. Structured and disciplined talk can enable learners to improve their reasoning.

Mercer (1996) emphasized that talk between learners is crucial in the construction of knowledge with underlining the idea that not all kinds of talk serve for this aim. Mercer (1996) described the features of talk that contributes to solution of problems and increasing understanding among the students. Mercer stated that it is the talk in which group members present their ideas clearly and explicitly so that they can be understood and evaluated well by all group members. And it is the talk in which group members reason together, share negotiation, evaluates claims and evidences and reach a consensus on the problem. Mercer also identified three conditions required for occurrence of this kind of talk. These conditions are:

- members have to talk to accomplish task.
- activity should support working and accomplishing together rather than encouraging individualized accomplishments.
- all group members should be aware of what the purpose of the task and how they will accomplish it.

Mercer's research works for group work and collaborative activities among learners. Teacher-led whole class discussions and group interaction among learners are two main contexts in which talk and language are related to the learning in schools (Mercer, Dawes, Wegerif, & Sams, 2004). Mercer et al. (2004) stated that learning in groups provides learners with many opportunities to develop different kinds of reasoning patterns (Mercer et al., 2004). In group activities or collaborative activities, learners can display a variety of ways to describe, explain, make connections, draw conclusions, and find solutions. They can be richer in terms of higher cognitive level interactions providing sustained and active engagement in learning (Galton, Hargreaves, & Pell, 2009) but it should be noted that group interactions may not always develop learning and reasoning if the conditions mentioned above are not satisfied. Learners can be off-task easily, uncooperative, and disruptive (Galton & Williamson, 1992).

Three ways of talking during collaborative group activities were identified as exploratory talk, disputational talk, and cumulative talk (Mercer, 1996). Exploratory talk is defined as

a joint, co-ordinated form of co-reasoning, in which speakers share relevant knowledge, challenge ideas, evaluate evidence, consider options, and try to reach

agreement in an equitable manner. By incorporating both constructive conflict and the open sharing of ideas, exploratory talk constitutes the pursuit of rational decision-making through dialogue. It depends not only upon the establishment of trust amongst partners, but also on the kind of intersubjectivity that enables them to achieve a shared understanding of the task in hand (Mercer, 2008, p. 95).

Disputational talk is portrayed by disagreement and individual decision making rather than sharing ideas, discussing alternatives and making decision as a group (Mercer, 1996). Mercer identified cumulative talk as building each others' ideas uncritically resulting in the accumulation of common knowledge without challenging and discussing ideas. Repetitions, explanations, confirmations are typical characteristics of cumulative talk. Exploratory talk is the talk in which "knowledge is made publicly accountable and reasoning is more visible in the talk" when compared to the others (Mercer, 1996, p. 369). Three kinds of talk can be observed in classroom environment but the research implies that exploratory talk is the rarest but the most important one for cognitive interactions.

In light of previous research, this study aimed to explore the types of talk occurring in small group discussions about digestive system. It also explored how talk may lead to more sophisticated reasoning.

THEORETICAL FRAMEWORK

This study was based on sociocultural theory. Mercer, Wegerif, and Dawes (1999) stated three functions of language in intellectual development according to the sociocultural theory. These are language as "cognitive tool" which students use in order to process knowledge; language as "social or cultural tool" which students use to share knowledge with peers; language as "pedagogical tool" which is used to support students' cognition. Language can function as social and cultural tool among students in the collaborative group activities guided by teachers who use language as pedagogical tool. As a result students' understanding and reasoning can develop through the use of language in a social environment.

METHOD

This study included twenty two seven-graders (four groups consisting of 5-6 students) worked on digestive system, specifically on the task "what happens to the food we eat". Students were required to negotiate how different kinds of food (bread, steak, butter) are processed through digestive system. Before activity, they were told some directions. They were required to ask questions and elaborate on others' responses. The questions should be to learn about student's ideas and underlying reasoning. Students were given such directions to make group work productive to improve learning and reasoning. In order to study these particular group's interactions and how they constructed meaning as they discussed digestion, field notes, transcripts of small-group discussions were analyzed qualitatively by two independent researchers. Interviews were conducted to understand group interactions and to explore more about their reasoning as a result of collaborative work. The analysis was based on the framework developed by Mercer (1996) to evaluate talk among students. For each group discussion, episodes of different talks were identified by two independent researchers and consistency between them was ensured.

RESULTS

The analysis of group discussions revealed that the four groups displayed all kinds of talk in varying amounts. However one group was engaged in exploratory talk more during their discussions. The other three groups were mostly involved in disputational and cumulative talk. The relative percentages of talk each group displayed were given in Figure 1.

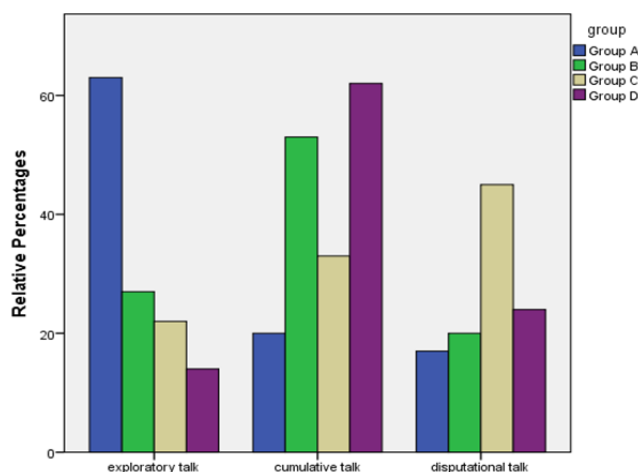

Figure 1. Comparison of Percentages of Talk Observed in each Group.

The Figure 1 reveals that Group A displayed exploratory talk considerably more than other groups (63%). Cumulative talk was mostly observed in Group B and D. More than half of discussions in Group B and D were characterized as cumulative talk. Disputational talk took place in similar percent in Group A, B, and D (around 20%). On the other hand, Group C displayed disputational talk frequently (45%). Group C is the one which was engaged in disputational talk most.

The comparative analysis among groups revealed that students engaged in exploratory talk showed explicit and more sound reasoning than students engaged in disputational or cumulative talk. The group interviews also supported that students engaged in exploratory talk displayed higher level of reasoning than other types of talk. Table 1 presents an example exploratory talk displayed in Group A.

Table 1. An Example Exploratory Talk Observed in Group A

Student A. Let's discuss the first one, bread. What do you think about digestion of bread?
Student B. It is digested as all foods.
Student A. But how? We should discuss this.
Student B. Ok. When we chew it, it becomes smaller.
Student C. I agree.
Student A. But being smaller means digestion?
Student C. Yes. But it is not the whole. There are some other processes.
Student B. What kind?
Student C. It goes to small intestine and is still digested there.
Student D. I have a question. Do you think it becomes even smaller in small intestine?
Student C. Umm!... should be so... I am not sure.
Student A. (Referring to student E) what do you think about it?
Student E. I think teeth help bread become smaller and saliva makes it softer but the real digestion starts in small intestine. Do you agree?
Student A. No. Saliva does not only make softer, it also includes some enzymes that start digestion of bread.
Student E. Ok. You mean that digestion starts in the mouth?
Student A. Yes but not all foods. It depends on the kind of food.
Student D. Does this mean different food requires different enzymes?
Student A. Sure, and in different digestive organs.
...

In the example above, five students focused on digestion of food. Student A started the discussion and encouraged others to present their ideas. These students not only presented their ideas but also elaborated on them. They asked questions to each other and clarified the ambiguities in the answers. This discussion helped students reason on concepts related to digestion. Student A mostly acted as a guide and helped others discuss about the topic. It was evident that this student was more knowledgeable about digestion and used his prior knowledge in the discussion.

DISCUSSION

The results revealed that three types of talk were observed in each group with different amount. The qualitative investigation of each group's discussion revealed that the group that exhibited exploratory talk showed in depth reasoning than other groups did. The students in this group asked questions which fostered further interpretation. The collaboration among them also helped the comprehension of the topic by relatively passive students. Talk, as an activity, provided opportunities for students to construct knowledge and develop reasoning with the aid of interaction with others. For group works and other collaborative activities in the classroom, talk has a potential role in contributing to the learning. Mercer (2008) stated that exploratory talk increases reasoning skills through interaction among group members who become more sophisticated users of language as a psychological tool. There are also other studies having similar findings which reveal that peer talking and discourse in the groups result in higher levels of reasoning through discussing and elaborating each others' ideas (Hogan, 2002; Mercer et al., 1999; Resnick et al., 2010). The results showed that students' knowledge about digestive system also influences the interaction and talk among them. The knowledgeable student in this group (Student A) guided the discussion and scaffolded others. This result is consistent with Vygotsky's (1978) claim that discourse and interaction among students can shape their individual mental processes. Dawes (2004) also emphasized that

group talk can help learners to exchange ideas, to have access to different perspectives and to make meaning together.

REFERENCES

- Dawes, L. (2004). Talk and learning in classroom science. *International Journal of Science Education*, 26, 677–695.
- Galton, M., Hargreaves, L., & Pell, T. (2009). Group work and whole-class teaching with 11- to 14-year-olds compared. *Cambridge Journal of Education*, 39(1), 119–140.
- Galton, M. J., & Williamson, J. (1992). *Group work in the primary classroom*. Routledge, Chapman & Hall, Incorporated.
- Hogan, K. (2002). Small groups' ecological reasoning while making an environmental management decision. *Journal of Research in Science Teaching*, 39(4), 341–368.
- Mercer, N. (1996). The quality of talk in children's collaborative activity in the classroom. *Learning and Instruction*, 6(4), 359–377.
- Mercer, N. (2008). Talk and the development of reasoning and understanding. *Human Development*, 51(1), 90–100.
- Mercer, N., Dawes, L., Wegerif, R., & Sams, C. (2004). Reasoning as a scientist: ways of helping children to use language to learn science. *British Educational Research Journal*, 30(3), 359–377.
- Mercer, N., Wegerif, R., & Dawes, L. (1999). Children's Talk and the Development of Reasoning in the Classroom. *British Educational Research Journal*, 25(1), 95–111.
- Resnick, L. B., Michaels, S., & O'Connor, C. (2010). How (well structured) talk builds the mind. *Innovations in educational psychology: Perspectives on learning, teaching and human development*, 163–194.
- Vygotsky, L. S. (1978). *Mind in society: the development of higher psychological processes* (Cambridge, MA, Harvard University Press).

BİYOLOJİ ÖĞRETMEN ADAYLARININ MEMELİLER HAKKINDAKİ GÖRÜŞLERİ

VIEWS OF PROSPECTIVE BIOLOGY TEACHERS ABOUT MAMMALS

Gülcan ÇETİN
Balıkesir Üniversitesi
gulcan_cetin@hotmail.com

Funda BEKAR
Balıkesir Üniversitesi
fundabekarr@hotmail.com

Aysun ÖZCAN
Balıkesir Üniversitesi
aysun-ozcan-@hotmail.com

Esra PEKDAĞ
Balıkesir Üniversitesi
esra_pekdag@hotmail.com

ÖZET: Bu araştırma, biyoloji öğretmen adaylarının memeliler hakkındaki görüşlerini belirlemek amacıyla yapılmıştır. Çalışma grubu, Balıkesir Üniversitesi Necatibey Eğitim Fakültesi Biyoloji Öğretmenliği 2. sınıfta öğrenim gören 23 öğretmen adayından oluşmaktadır. Veriler, 6 açık uçlu sorudan oluşan Memeliler Anketi ile toplanmıştır. Veriler, içerik analizi tekniğine göre analiz edilmiştir. Elde edilen sonuçlara göre, biyoloji öğretmen adaylarının memelileri gruplandırma bazı sorunlar yaşadıkları gözlenmiştir. Öğrenciler özellikle gagalı memeli kavramında sorun yaşamaktadırlar.

Anahtar Kelimeler: memeliler, gagalı memeli, keseli memeli, plasentalı memeli, biyoloji öğretmen adayı

ABSTRACT: This research aimed to determine the views of prospective biology teachers about mammals. Study group consisted of 23 students who studying at the second grade of biology teaching in Necatibey Faculty of Education in Balıkesir University. Data were collected by Mamals Questionnaire including six open-ended questions. Data were analyzed using by content analysis technique. According to the results, it has been observed that prospective biology teachers had some problems in classification of mammals, especially regarding the concept of ornithorhynchus.

Key words: mammals, ornithorhynchus, marsupials, placental mammals, prospective biology teachers

ARGUMENTATION IN PEER-GUIDED VERSUS TEACHER-GUIDED GROUP DISCUSSIONS

Nurcan CANSIZ
Atatürk University
nurcansiz7911@gmail.com

Mustafa CANSIZ
Artvin Çoruh University
mustafacansiz@gmail.com

ABSTRACT: This study investigated argumentation patterns resulting in teacher-guided and peer-guided group discussions on four socioscientific-issues (SSI). Two groups, each including five students from grade 7, studied on a different SSI during four weeks. Discussions within both groups were observed, videotaped, and analyzed qualitatively. After four weeks, group interviews were conducted. The results showed that teacher-guided group presented more complex argumentation patterns than peer-guided group. Both groups supported their claims with scientific and non-scientific evidence. But teacher-guided group presented the evidence deeply. The results suggested that teachers should have the related pedagogical skills to put argumentation into practice and to explore the students' skills in constructing arguments in the context of SSI. The implications for science educators and researchers were discussed.

INTRODUCTION

It is important for individuals to be competent in science content knowledge, to have argumentation skills, and to make informed decisions to be responsible citizens which are also among the key elements of scientific literacy. Scientific literacy is defined as a multidimensional construct including "being able to use scientific knowledge and ways of thinking for personal and social purposes" (AAAS, 1990, pp. xvii-xviii). It is important to be a scientifically literate person in this century which is full of scientific and technological developments. Scientifically literate individual is the one who "use appropriate scientific processes and principles in making personal decisions" and "engage intelligently in public discourse and debate about matters of scientific and technological concern" (NRC, 1996, p. 13). To sum up, scientific literacy is related to one's knowledge about science, technology, society and the relationship between them and scientifically literate person is the one who uses her/his scientific literacy in order to make decisions for complex issues which are not only scientific but also social and technological. These issues are called as socioscientific issues (SSI) and defined as intricate and open-ended having no certain answers (Sadler, 2003). They are controversial in nature and likely cause an argument. Being questionable makes SSI debatable therefore opposing ideas emerge against those issues. Dawson and Venville (2010) emphasized that school science should focus on necessary skills, knowledge, and comprehension to deal with socioscientific issues since individuals should be able to evaluate their pros and cons, ask questions, assess the information in terms of different perspectives and finally reach balanced, reasonable, and informative decisions. In light of this, this study investigates the argumentation patterns and quality of argumentation in grade seven students' small group discussions about different SSIs with and without teacher guidance. The specific research question guided this study was: What are the argumentation patterns and the quality of argumentation within teacher-guided and peer guided small group discussions?

THEORETICAL FRAMEWORK

In this study, sociocultural approach of learning was drawn on to comprehend how students grapple with different socioscientific issues. Jimenez-Aleixandre and Erduran (2007) underlined two aspects of argumentation; justification of claims and persuading audience. The former is related to the connection between reasoning process, theoretical ideas and empirical evidence to justify the claim. The latter is what you claim and advocate by evidence aim to persuade the audience for your argument. Jimenez-Aleixandre and Erduran (2007) foreground sociocultural approach as a framework laying stress on socialization for learning and thinking through the use of language. Argumentation is a form of discourse underlying learning in social context through the interaction of learners. Sociocultural approach basically explains the mental processes in human mind with an emphasis on the relation between these processes and the context and human communicative practices instigate these processes (Wertsch, 1991). Wertsch states that this approach works for academic discussions as well as everyday events.

LITERATURE REVIEW

Argumentation is defined as a claim furnished by corroborating justification (Kolstø & Ratcliffe, 2007). Researchers studying argumentation in teaching and learning science stated that argumentation should be integrated into science education and researchers should contribute to the progress of it (i.e. Driver, Newton, & Osborne, 2000). Driver et al. (2000) argued that science is not only observation and experimentation but also includes disagreements which contribute to the construction of scientific knowledge. These disagreements result in the engagement with claims, evidence, counter claims, rebutting claims and changing hypotheses.

The related literature shows that most of the studies in socioscientific issues focused on the argumentation as a means to resolve socioscientific issues (Jimenez-Aleixandre, Rodriguez, & Duschl, 2000; Kortland, 1996; Patronis, Potari, & Spiliotopoulou, 1999; Zohar & Nemet, 2002). Kortland (1996) studied the argumentation patterns with the middle school students in the content of environment, specifically waste management and recycling. The results of the study guide Kortland to make the conclusion that students have the ability to create a basic argument, on the other hand he reported that the arguments generated are not clear, limited and not applicable. Patronis et al.'s (1999) study revealed opposite findings to the Kortland's study. They suggested that middle school students could develop strong arguments in the context of socioscientific issues. SSI, being controversial in nature with different scientific and social dimension, is an appropriate context to engage students in argumentation. It creates such a classroom environment in which students develop claims, counter claims including evidence to justify them. Therefore classroom practices might be useful to engage students in argumentation in the context of SSI.

METHOD

This study investigated the argumentation patterns resulting in teacher-guided and peer-guided group discussions on four SSIs (hydroelectric power plant, nuclear power plant, genetically modified food, and research conducted on animals). Participants of the study were ten Grade 7 students who worked as groups of five. They studied on a different SSI each week for a total of four weeks. Discussions within both groups were videotaped, transcribed, and analyzed qualitatively. They were also observed by researchers. After four weeks, group interviews were conducted on discussions. The nature and quality of students' argumentation patterns were analyzed through Toulmin Argumentation Pattern (TAP) (Toulmin, 1958) and the analytical framework developed by Erduran, Simon, and Osborne (2004). Table 1 gives the analytical framework used in this study.

Table 1. Analytical Framework to Assess the Quality of Argumentation

Level 1	Level 1 argumentation consists of arguments that are a simple claim versus a counter-claim or a claim versus a claim
Level 2	Level 2 argumentation has arguments consisting of a claim versus a claim with either data, warrants, or backings but do not contain any rebuttals.
Level 3	Level 3 argumentation has arguments with a series of claims or counter-claims with either data, warrants, or backings with the occasional weak rebuttal.
Level 4	Level 4 argumentation shows arguments with a claim with a clearly identifiable rebuttal. Such an argument may have several claims and counter-claims.
Level 5	Level 5 argumentation displays an extended argument with more than one rebuttal.

RESULTS

In particular, we were interested in comparing the nature of arguments generated in the small groups with and without teacher guidance on different SSIs. Transcripts of two group discussions were examined for episodes of argumentation clusters. Erduran et al. (2004) defined clusters as permutations of Toulmin Argumentation Pattern such as "claim-data-warrant" or "claim-data-rebuttal". We aimed at identifying argumentation clusters and assigning levels for both type group discussions.

Teacher-guided group discussions: These discussions were guided by the teacher. The group was informed about four SSIs with short stories including a few directions about what they were required to do. Teacher asked the driving question about each socioscientific issue during discussions and let the students discuss. He did not

directly state his personal ideas and thoughts and give any specific information. Instead he asked questions to clarify and elaborate on students' ideas and encouraged them to participate in discussions. The teacher was knowledgeable about argumentation and practiced it in his classes before. Therefore he did not have difficulties in guiding students to present elements of argumentation. The most evident result in teacher-guided group discussions was that students experienced a higher level of argumentation (see Figure 1). They referred to scientific evidence to support themselves in addition to the non-scientific ones. For example they referred to water cycle in supporting their claims about hydroelectric power plant. Students' lived experiences were also found to be influential in presenting their claims and evidence. In one of the discussions, for example, one student told that his relatives were forced to abandon their home due to the construction of hydroelectric power plant by the authority because their home was in that region. This student felt upset because of this and opposed to the construction of it.

Peer-guided group discussions: This group did not receive any guidance from teacher during their discussions. The group was given the same short stories as teacher-guided group about four SSIs and they were given the same directions about what they were required to do. They negotiated on each issue with their peers. The researcher observed their discussions to ensure that they were on task and there is no off-task behavior. The group members shared their ideas. However they could not elaborate on them further. The most evident result in peer-guided group discussions was that students could not experience a higher level of argumentation as in teacher-guided group discussions (see Figure 1). Similar to other group, they referred to both scientific and non-scientific evidence to support themselves. However their scientific evidence was so superficial. For example, one student supported the construction of hydroelectric power plants due to electricity production but neither he nor other group members elaborated on this.

Table 2 presents an example for how the nature and quality of arguments differed in both groups' discussions in the context of hydroelectric power plant. It was evident that teacher-guided group experienced a more sophisticated level of argumentation than peer-guided group.

Table 2. An Example Argumentation Patterns in Teacher-Guided and Peer-Guided Discussions

	Example (Level)	
	<i>Teacher-guided</i>	<i>Peer-guided</i>
Hydroelectric power plant	<p>Student A: I think hydroelectric power plants should not be constructed because it takes water from nature and water becomes less.</p> <p>Teacher: Do you mean the amount of water in nature reduces?</p> <p>Student A: Yes.</p> <p>Student B: I do not think that water is used up [by hydroelectric power plants] and reduced.</p> <p>Teacher: What do you mean? Do you mean that hydroelectric plants do not change the amount of water in nature or they increase it?</p> <p>Student B: I think water is not used up [by hydroelectric power plants]. Those plants collect water together and let the water turn turbines through energy transformation and produce electricity. If they used up water, the amount of it in nature would not reduce</p>	<p>Student F: Hydroelectric plants are necessary because they produce electricity.</p> <p>Student G: I think so because it is also important for economical developments.</p> <p>Student H: You may be right in your views but it damages environment and ecosystem and people protest it.</p> <p>Student F: Ok it may have some disadvantageous but electricity is vital in our lives and it is more important. Can you do your homework without electricity at home (referring to Student H)? Of course no! (<i>Level 2</i>)</p>

because there is water cycle in nature.
(Level 4)

The chart in figure 1 shows the distribution of level of arguments which were obtained from two groups' discussions during four weeks. This chart shows that teacher-guided group performed better in terms of nature and quality of argumentation than peer-guided group. The students engaged in more sophisticated argumentation patterns when the teacher guided the discussion. Level 5 argumentation was not observed in both groups. Peer-guided group could reach level 3 argumentation at most.

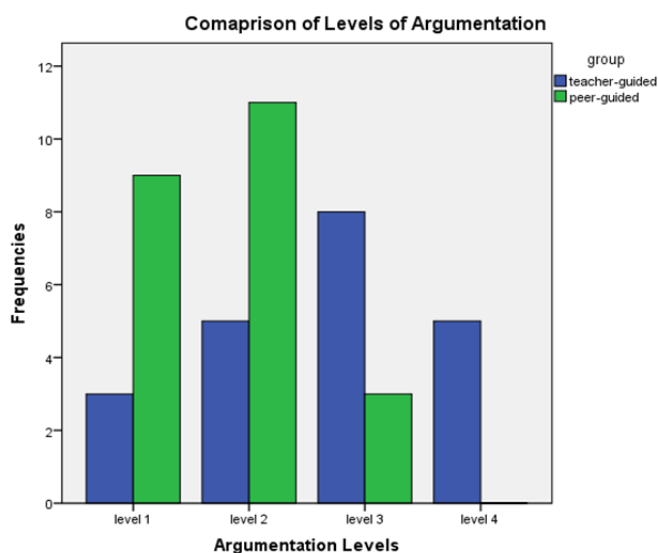

Figure 1. Comparison of Argumentation Levels for Teacher-Guided and Peer-Guided Groups

DISCUSSION

The results showed that teacher-guided group presented more complex argumentation patterns than peer-guided group (see Figure 1). Teacher-guided discussions were more informative and included high quality argumentation. Peer-guided group could not achieve complex argumentation patterns. Both groups supported their claims with scientific and non-scientific evidence. But teacher-guided group presented the evidence deeply. The teacher in this study experienced argumentation before and guided students in presenting different elements of argumentation competently. The questions he asked directed students to a more complex argumentation. In light of this, the results suggested that teachers should have the related pedagogical skills to put argumentation into practice and to explore the students' skills in constructing arguments in the context of SSI. As a result this will contribute to educating students as responsible citizens who are capable of engaging in public discussions about social issues which influences their lives.

This study will contribute to science educators and researchers' general interest in terms of argumentation and its implementation in SSI context. It will also inform them about results for teacher or peer guided group discussions.

REFERENCES

American Association for the Advancement of Science (AAAS). (1990). Science for all Americans. New York: Oxford University Press.

- Dawson, V. M., & Venville, G. (2008). Teaching strategies for developing students' argumentation skills about socioscientific issues in high school genetics. *Research in Science Education*, 40(2), 133–148.
- Driver, R., Newton, P., & Osborne, J. (2000). Establishing the norms of scientific argumentation in classrooms. *Science education*, 84(3), 287–312.
- Erduran, S., Simon, S., & Osborne, J. (2004). TAPping into argumentation: Developments in the application of Toulmin's argument pattern for studying science discourse. *Science Education*, 88(6), 915–933.
- Jimenez-Aleixandre, M. P., Rodriguez, A. B., & Duschl, R. A. (2000). "Doing the lesson" or "doing science": Argument in high school genetics. *Science Education*, 84, 757 – 792.
- Jiménez-Aleixandre, M. P., & Erduran, S. (2007). Argumentation in science education: An overview. In S. Erduran & M. P. Jiménez-Aleixandre (Eds.), *Argumentation in Science Education* (pp. 3–27). Springer Netherlands.
- Kortland, K. (1996). An STS case study about students' decision making on the waste issue. *Science Education*, 80(6), 673–689.
- Kolstø, S. D., & Ratcliffe, M. (2007). Social aspects of argumentation. In S. Erduran & M. P. Jiménez-Aleixandre (Eds.), *Argumentation in Science Education* (pp. 117–136). Springer Netherlands.
- National Research Council. (1996). *National science education standards*. Washington, DC: National Academy Press.
- Patronis, T., Potari, D., & Spiliotopoulou, V. (1999). Students' argumentation in decision-making on a socioscientific issue: Implications for teaching. *International Journal of Science Education*, 21, 745 – 754.
- Sadler, T. D. (2003). Informal reasoning regarding socioscientific issues: The influence of morality and content knowledge. (Doctoral dissertation, University of South Florida, 2003).
- Toulmin, S. (1958). *The uses of argument*. Cambridge: Cambridge University Press.
- Wertsch, J. V. (1991). *Voices of the mind: A sociocultural approach to mediated action*. Cambridge, Mass: Harvard University Press.
- Zohar, A. & Nemet, F. (2002). Fostering students' knowledge and argumentation skills through dilemmas in human genetics. *Journal of Research in Science Teaching*, 39, 35–62.

BESİN ZİNCİRİ VE BESİN AĞI KONULARINDA YARATICI DRAMA ETKİNLİKLERİ: ÖRNEK BİR DERS İŞLEYİŞİ

FOOD CHAINS AND FOOD NETWORK ACTIVITIES FOR THE CREATIVE DRAMA: AN EXAMPLE OF LESSON PROCESS

Doç. Dr. Sacit KÖSE
Pamukkale Üniversitesi, Eğitim Fakültesi, Biyoloji Eğitimi ABD
sacitk@pau.edu.tr

Ayşe FİLİZ (Yüksek Lisans Öğrencisi)
Pamukkale Üniversitesi, Eğitim Bilimleri Enstitüsü
a_filiz1@hotmail.com

ÖZET: Son yıllarda çevre sorunlarının insanlığın geleceğini tehdit eder boyutlara ulaşması, ekoloji biliminin önemini arttırmıştır. Ekosistemde durmaksızın süren bir madde ve enerji akışı görülmektedir. Döngünün doğal yapısının bozulmaması tüm canlılar için büyük önem taşır. Uygarlığın ilerlemesiyle insanoğlu doğaya birçok yapay madde atmıştır. Bu maddelerin bazılarının zararsız forma dönüştürülebilmesi imkansızdır. Bunun sonucunda besin zincirinin halkalarındaki canlılarda bu maddeler birikerek hasarlara yol açmaktadır. Bu sorunların pek çok nedeni olmakla birlikte en önemli nedenin insanların çevreyi bilinçsizce kullanması gösterilmektedir. Bu açıdan bakıldığında çevrenin korunması ve kirliliğin azaltılması ancak yaşadığı çevreye karşı bilinçli, doğayı ve canlıları seven, koruyan bireyler yetiştirmekle gerçekleştirilebilir.

Biyoloji derslerinde yaratıcı drama güçlü bir öğretim aracıdır. Çevresel sorunlar yaratıcı drama teknikleri kullanılarak oynusu süreçlerle canlandırılır.

Bu çalışmanın amacı, ekosistem ekolojisi ünitesindeki besin zincirleri ve besin ağları konularında hazırlanan yaratıcı drama etkinliklerinin uygulanmasına yönelik bir ders işlenişini sunmaktır. Bu şekilde konuların etkili bir şekilde öğrenileceği ve bu konu üzerinde çalışma yapan araştırmacılara faydalı olacağı düşünülmektedir.

Anahtar kelimeler: ekosistem, ekoloji, yaratıcı drama, 10. sınıf öğrencileri

ABSTRACT: As in recent years, environmental problems reach the dangerous levels for the future of human; the importance of ecological science is increased. In ecosystems the flow of unceasingly substance and energy are seen the deterioration process of natural structure carries weight with all lives. With the progress of civilization, humankind throws away lots of artificial items to the nature. It is impossible to change some of these items to harmless forms. At the end of this, lives accumulated these items result in to damage. As together with many reasons, the most important reason is displayed the unconscious usage of human. When viewed from this angle environmental protection and reduction of pollution can be actualized by training environmentally conscious, nature-loving environment, protecting individuals.

Creative drama is a powerful teaching tool in Biological lesson. Environmental problems are illustrated with playful process by using creative drama techniques.

The aim this study is to present a lesson process with implementation of Creative drama activities about food chain and food web subjects prepared in Ecology unit .Thus, it is considered that the subjects will be taught effectively and it will be useful to the researchers studying on this subject.

Key words: ecosystem, ecology, creative drama, 10 grade students

GİRİŞ

Ülkeler eğitim kurumlarını çağdaş, karar alma ve uygulama becerisine sahip, hayatı algılayabilen ve sorgulayabilen, kendine güvenen, iletişim kurma ve ekiple çalışma yönü gelişmiş, kitleleri etkileyebilen bireyler yetiştirebilmek için planlamak ve programlamak zorundadırlar (Gürol, 2003; Karakaya, 2007).

Bu zorunluluk klasik öğretim anlayışından uzaklaşarak öğreneni merkeze alan ve öğretmeni öğrenme sürecine rehber kılan pek çok yeni öğretim yöntem ve tekniklerinin gelişmesine olanak sağlamıştır . Eğitim öğretimin sürecindeki bu yeni oluşumlardan biri de yaratıcı drama yöntemidir (Karakaya, 2007).

Yaratıcı Drama, bireylerin bir grup çalışması içinde, doğaçlama, rol oynama gibi tekniklerden yararlanarak, bir yaşantıyı, olayı, fikri eğitim ünitesini; kimi zamanda bir soyut kavramı, eski bilişsel örüntülerin yeniden düzenlenmesi yoluyla ve gözlem, deneyim, duygu ve yaşantıların gözden geçirildiği ‘oyunsu’ süreçlerde anlamlandırılması ve canlandırılmasıdır (San 1996).

Yaratıcı drama, temelde bireylerin birbirleriyle iletişim ve rol alma yeteneklerini barındırır. Bu yetenek, insanın doğasında var olduğuna inanılan sosyal ve duygusal özellikleri yansıtır (Wright, 2006). Öğrenme sürecinde bireyin öğrenmeyi nasıl gerçekleştireceği, ne kadar öğrendiği, ne zaman ve kimden yardım isteyeceği, öğrenme süreçleri vb. ile ilgili kararları yaratıcı drama yöntemi ile kazandırabiliriz. Geleneksel öğretimde bunların çoğuna öğretmen karar vermektedir. Yaratıcı drama yönteminde ise bu sürecin sorumluluğu öğrenendedir ve öğretici sadece yol göstericidir.

Tüm bunlar göz önünde bulundurulduğunda ortaöğretim Biyoloji dersi müfredatındaki ekosistem ekolojisi ünitesinde yer alan besin zincirleri ve besin ağları konusunun yaratıcı drama yöntemleriyle işlenmesinin öğrencilerin biyoloji konularının yaşamın bir parçası olduğunu fark etmelerini, Biyoloji dersine bakış açılarının değişmesini ve Biyoloji dersine ilgi duymalarını ve bununda daha etkili, daha kalıcı bir öğrenmeyi sağlayabileceği düşünülmektedir.

YÖNTEM

Besin zinciri ve enerji piramidi konusu ile ilgili hazırlanan yaratıcı drama etkinliği öğrencilere uygulanacaktır.

Drama Ders Planı

Ders: Biyoloji

Konu: Besin zincirleri ve besin ağları

Katılımcılar: 10.sınıf öğrencileri (14 kişi)

Süre: 3 saat

Yöntem ve Teknikler: Doğaçlama, Rol oynama, Hikaye tamamlama

Araç gereçler: Cd çalar, Cd, yazı tahtası, tahta kalemi, renkli kartonlar, makas, yapıştırıcı, renkli eliş kağıtları, pastel boyalar

Kazanımlar:

- Besin zincirini ve besin zincirini oluşturan faktörleri kavrar.
- Besin zincirini oluşturan üretici, tüketici ve ayrıştırıcı canlıların görevlerini söyler.
- Besin ağı ile besin zinciri arasındaki ilişkiyi fark eder.
- Besin zincirindeki enerji akışını açıklar.
- Biyolojik birikimin nasıl gerçekleştiğini fark eder.

Süreç

Hazırlık –ısınma:

1. Etkinlik

Çember olunur müzik eşliğinde serbest yürüme etkinliği yapılır. Öğretmenin verdiği yönergeye göre herkes en yakınındaki kişi ile eşleşir. Öğretmen öğrencilere kısa bir gezintiye çıkacaklarını söyler. Gezinti sırasında eşlerden birinin gözleri kapalı olur ve diğer kişi gözleri kapalı olan arkadaşına çevresinde gördüğü resimlerden yola çıkarak bir hikaye anlatmaya başlar ve onu yürüyüş boyunca yönlendirir ve güvenliğini sağlar. Aynı uygulama diğer eş için de tekrarlanır.

Uygulama bittikten sonra anlatılan hikayeler ana hatlarıyla dinlenir. Hikayelerdeki ortak noktalar çıkarılır.

Öğretmen, öğrencilere insanların, hayvanların ve bitkilerin yaşamlarını sürdürebilmesi için nelere ihtiyaç duyduklarını sorar ve cevaplarını alarak konuya giriş yapar.

Öğretmen besin zincirinin üretici tüketici ve ayrıştırıcılardan oluştuğunu ve bu zincirde üreticiden tüketiciye doğru birey sayısının ve aktarılan enerjinin azaldığını vücut büyüklüğü ve aktarılan toksin madde miktarının arttığını anlatır.

2. Etkinlik

Öğrencilerle çember oluşturulur. Öğrencilerin her birinin boynuna bir varlığın resmi asılır. Öğrencilerden bir tanesinin eline ip yumağı verilir. Öğretmenin verdiği komuta göre öğrenci ipin ucundan tutarak yumağı ilgili kişiye atar. Yumağı tutan kişi yumağı atan kişi ile ilgili nasıl bir ilişki içinde olduğunu söyler. Etkinlik bu şekilde devam eder.

3. Etkinlik

Öğrenciler iki gruba ayrılır. Her gruba bir zarf verilir. Zarfların içinde çeşitli yönergeler vardır. Öğrencilerin yönergeleri sırasıyla takip etmeleri ve oyunu en kısa sürede bitirmeleri söylenir. Etapları en kısa sürede bitiren takım oyunu kazanacaktır.

Yönergeler

- ✚ Her grup birer sepet bulsun.
- ✚ Sepetinize çevrede bulunan 20 bitkiyi doldurun.
- ✚ Etrafta dolanan farelerden (fare resimleri) 5 tane toplayın.
- ✚ Şimdi beslenme zamanı sepetinizdeki bitkileri farelere yedirin.(bitki resimleri ile fare resimlerini bantla yapıştırın)
- ✚ Fareleri doğal ortamlarına bırakın. (dağınık şekilde)
- ✚ Şimdi yılan avına çıkıyoruz. Çevrede dolanan 5 yılan yakalayın.
- ✚ Elinizdeki 5 yılan için 10 fare yakalayın .(Her yılan resmine 2'er fare yapıştırın)
- ✚ Yılanları ormana bırakın. (dağınık şekilde)
- ✚ Şimdi kartallar belirdi etrafta bu kartallardan 3'er tane tutun.
- ✚ Kartalların karnı açılmış. Avlanma zamanı!
- ✚ Her kartal 3 yılan avlasın. (Kartal resimleriyle yılan resimlerini yapıştırın)
- ✚ Şimdi bitiş noktasına kartallarınızı getirin.
- ✚ Kartal resimleriyle yapışık olan hayvan resimlerini çıkarın. (Her bir kartal için ayrı ayrı)
- ✚ Tüm resimlerde bulunan siyah benekleri sayın.
- ✚ Sayımı doğru şekilde ilk yapan oyunu kazanır.

Öğretmen oyundan sonra öğrencilerin düşüncelerini dinler. Daha sonra bu siyah beneklerin ne olabileceği ile ilgili tahminlerinin olup olmadığını sorar.

Ara değerlendirme

Etkinliğin sonunda söz almak isteyen öğrencilere konuşma fırsatı verilir. Öğretmen doğadaki canlıların birbirleriyle etkileşim halinde olduğunu anlatır. Besin zincirleriyle besin ağı arasındaki ilişkiyi belirtir. Besin zinciri yoluyla canlılardaki biyolojik birikimin etkilerinden bahseder.

Canlandırma

4. Etkinlik

Öğretmen öğrencilerin konu ile ilgili temel kavramları içeren resimlere tekrar göz atmasını ister. Öğrencilerden yeni öğrendikleri bilgilerle resimler arasında ilişkiler kurması ve bu ilişkileri yorumlaması istenir. Doğru yorumlamalara ulaşıncaya kadar öğretmen öğrencileri çeşitli ipuçlarıyla yönlendirir.

Öğrencilerle çember olunur. Sırasıyla üretici-tüketici-ayrıştırıcı kelimeleri söylenerek öğrenciler üç gruba ayrılır. Her gruba farklı resimler verilir. Verilen fotoğraflara göre grupların konuyla ilgili resim, şiir ve kolaj çalışmaları yapmaları istenir. Hazırlanan çalışmalar öğretmen tarafından kontrol edilir. Gruplar çalışmalarını sergiler.

5. Etkinlik

Öğrencilerle çember olunur. Sırayla önce-sonra denilerek iki grup oluşturulur. Öğrencilere verilen fotoğraflardan yola çıkılarak öğrencilerin fotoğrafların öncesi ve sonrasını canlandırması istenir. Öğrencilere hazırlanmaları için süre verilir ve canlandırmaları izlenir.

Değerlendirme

6. Etkinlik

Öğretmen öğrencilere üzerinde “Bugün öğrendim ki” yazan kağıtları dağıtır. Bugünkü çalışmada öğrendiklerinden yola çıkarak boşlukları tamamlamaları ve daha sonra bu kağıtları duvara yapıştırmalarını söyler. Daha sonra tüm kağıtlar okunur. Çalışma ile ilgili öğrencilerin görüşleri alınır.

7. Etkinlik

Öğrenciler sırasıyla Zincir -Ağ diyerek iki gruba ayrılır. Zincir grubunun Besin piramidi oluşturmaları ağ grubunun besin ağı oluşturmaları bunları yaparken de öğrencilere verilen dergilerden gazetelerden de faydalanmaları söylenir. İki çalışmada da yapılan çalışmanın özelliklerin belirtilmesi gerektiği vurgulanır. Çalışmalar bittikten sonra her grup kendi çalışmasını sergiler.

BULGULAR

Araştırma, ortaöğretim 10. sınıf Biyoloji dersi “Ekosistem Ekolojisi ” ünitesinde yürütülecektir.

Kontrol grubunu 14, deney grubunu 14 öğrenci oluşturacaktır.

Çalışma iki grupta da dersin öğretmeni olan araştırmacı tarafından yürütülecektir.

Deney ve kontrol gruplarına çalışmanın başında ön testler uygulanacaktır.

Uygulama sonunda da son testler uygulanacaktır.

Çalışmadan önce deney grubuna ders konusu dışındaki etkinliklerle yaratıcı drama hakkında bilgi verilecektir.

Yaratıcı drama etkinlikleri, ekosistem ekolojisi ünitesi kazanımlarını içerecek şekilde araştırmacı tarafından planlanmıştır.

SONUÇ

Öğrencilerin dünya hakkındaki kavramları anlama, yeni bakış açıları geliştirme ve yorumlama becerilerinin geliştirilmesinde fen öğretimi önemli bir etkidir. Fenin günlük hayatla ilişkili kısmı, sınıflarımızda ihmal edilmiş durumdadır.

Fen eğitimindeki yaparak yaşayarak öğrenme ,yaratıcı dramadaki yaparak yaşayarak öğrenme ilkesi ile bir bütünsellik içerisindedir. Çevresel sorunların çözümünde, bireylerin çevreyi tanıyıp korumalarında ve çevrenin insan hayatındaki önemini anlamaları konusunda biyoloji eğitiminin önemi büyüktür (Yüzbaşıoğlu ve Atav, 2004).

Bir öğretim yöntemi olarak yaratıcı dramanın Biyoloji dersinde kullanılmasının kalıcı öğrenmeyi gerçekleştirmede etkili olabileceği düşünülmektedir.

Biyoloji dersinde yaratıcı dramanın yöntem olarak kullanıldığı çalışma sayısı oldukça azdır. Bu nedenle yapılan bu çalışmanın alan yazınına katkı sağlayabileceği, Biyoloji öğretmenlerine yol gösterebileceği ve öğrencilerin Biyoloji dersi ile ilgili tutumlarının olumlu yönde değiştirilebileceği düşünülmektedir.

KAYNAKLAR

1. Aydoğdu, M. (2009). Fen Eğitiminde Çevre. Ankara: Pozitif Matbaacılık
2. Gürol, A. (2003). Okul Öncesi Öğretmenleri İle Okul Öncesi Öğretmen Adaylarının Eğitimde Dramaya İlişkin Kendilerini Yeterli Bulma Düzeylerinin Belirlenmesi. Fırat Üniversitesi Sosyal Bilimler Dergisi, Cilt:13, Sayı:2, Sayfa:147-165, Elazığ
3. Karakaya, N. (2007). İlköğretimde Drama ve Örnek Bir Uygulama. Gazi Üniversitesi, Gazi Eğitim Fakültesi Dergisi, Cilt 27, Sayı I(2007) 103-139, Ankara
4. Karaman, S. (2006). Hayvansal Üretimden Kaynaklanan Çevre Sorunları ve Çözüm Olanakları, KSÜ. Fen ve Mühendislik Dergisi,Cilt:9, Sayı:2, Sayfa:133-139. Karataş, S., Özcan, S. (2010), Yaratıcı Düşünme Etkinliklerinin Öğrencilerin Yaratıcı Düşüncelerine ve Proje Geliştirmelerine etkisi, Ahi Evran Üniversitesi Eğitim Fakültesi Dergisi,Cilt 11,Sayı 1,Nisan 2010,Sayfa 225-243
5. Yüzbaşıoğlu, A. ve Atav, E. (2004). Öğrencilerin Günlük Yaşamla İlgili Biyoloji Konularını Öğrenme Düzeylerinin Belirlenmesi, Hacettepe Üniversitesi Eğitim Fakültesi Dergisi, Sayı:26, Sayfa:276-285.
6. San, İ. (1996). Yaratıcılığı Geliştiren Bir Yöntem Ve Yaratıcı Bireyi Geliştiren Bir Disiplin: Eğitsel Yaratıcı Drama. Yeni Türkiye Dergisi, 2(7), 148-160.
7. Wright, P. R. (2006). Drama Education and Development of Self: Myth or Reality? Social Psychology of Education (2006) 9:43-65.

REHBERLİKLİ KEŞFETME VE ETKİLİ ÖĞRENME

GUIDED EXPLORATION AND EFFECTIVE LEARNING

Şeyda BİRİNİ
Bayburt Üniversitesi
seydamatbirni@gmail.com

Zekeriya KARADAĞ
Bayburt Üniversitesi
zekeriya@bilelim.net

ÖZET: Dönüşüm geometrisi öğrenirken ve öğretirken birçok zorluğun yaşandığı bir konudur. Yaşanılan zorlukların temelinde öğrencilerin yeteri kadar görsel ile desteklenmemeleri ve öğrencilerin kendi bilgilerini kendilerinin inşa edememesi yatabilir. Öğrencilerin görsel öğrenmelerine ve dönüşüm geometrisini daha etkili öğrenmelerine yardımcı olmak için Dinamik ve Etkileşimli Matematik Öğretme Programı olan GeoGebra'yı kullanarak hazırladığımız ders modelini eylem araştırması ilkeleriyle araştırdık. Çalışmamızda, verileri video kaydı ile topladık ve daha sonra verileri içerik analiz yöntemi ile analiz ettik. Analiz sonucunda bulduğumuz temalar rehberlikli öğretim, rehberlikli keşfetme (açınsama) , rehberliğin miktarı, dikkat ve etkili öğrenmedir. Başlangıçta rehberlikli öğretimin baskın olduğunu zamanla azalıp yerini rehberlikli keşfetmeye (açınsamaya) bıraktığını ve katılımın zaman içinde arttığını gözlemledik. Rehberliksiz öğretimin kavram yanlışlarına ve eksik bilgilere sebebiyet verme ihtimali olduğu için rehberlikli öğretimin olması gerektiğini destekleyen bulgulara ulaştık. Rehberlikli öğretimin yerini rehberlikli keşfetmeye (açınsamaya) bırakması ile öğrencilerin derse katılımlarının daha da arttığını ve en önemlisi onlara keşfetme imkânı bulmalarına yardımcı olduğunu gösteren ipuçları elde ettik. Bunlara ek olarak açınsamaya fırsat verildiği için etkili öğrenmenin gerçekleştiğini gözlemledik.

Anahtar sözcükler: rehberlikli eğitim, rehberlikli keşfetme, etkili öğrenme, rehberlik miktarı ve derse katılım

ABSTRACT: Learning and teaching of transformation geometry is an issue that has many challenges One reason of the case could be that in the class they have limited access to visual learning. Other reason could be that students lack constructing their own knowledge even if they have opportunities to interact with visual materials. In order to help students improve visual thinking and better learn transformational geometry we prepared lesson model using a Dynamic and Interactive Mathematics Learning software GeoGebra. We used action research method. Data was collected by videotaping and analyzed qualitatively. After analyzing, we found guided instruction, guided exploration, effective learning, amount of guidance and involvement. At the beginning we found that guided instruction was dominant in time it decreased and guided instruction increased. By this, we got that students' involvement increased and most importantly we obtain that students can get opportunity to explore and effective learning.

Key words: guided instruction, guided exploration, effective learning, amount of guidance and involvement

GİRİŞ

Kişisel deneyimlerimiz göstermektedir ki, dönüşüm geometrisinin geleneksel sınıf ortamlarında öğrenilmesinde ve öğretilmesinde birçok sorunlar yaşanmaktadır. Öğretmenlerin yaşadıkları zorluklar çizimlerinin hatalı olması, çok fazla çizim yapılamaması ve öğrenme zamanının yeterli olmamasıdır. Yani, öğrenciler görsel olarak yeterince desteklenmemektedirler ve dolayısıyla öğrenciler kendi bilgilerini inşa etme imkânı bulamamaktadırlar. Yapılan araştırmalar Dinamik Etkileşimli Öğrenme Ortamları (DIMLE) (Karadağ, Martinovic, & Freiman, 2011; Martinovic, & Karadağ, 2012) sunan yazılımların öğretmenlere bilgiyi keşfettirecek ve görselliği sağlayabilecek etkinlikler tasarlama imkânı verdiğini belirtmiştir. Bu programlar geometriyi statik bir yapı olan kâğıt - kalemde kurtarır ve dinamik hale getirerek öğrencilerin varsayımda bulunmalarına öğrencilerin varsayımda bulunmalarına, teorem ve ilişkileri keşfetmelerine ve bunları test etmelerine imkân sağlar (Güven, 2002)

DIMLE matematik öğrenimini geliştirmek için tasarlanmış Cabri, Geometer's SketchPad, Fathom, GeoGebra, Geocadabra gibi yazılımları içerir. Bu yazılımların özellikleri matematiksel nesnelerin oluşturulacağı ortamlar ve bu nesneler ile özgürce etkileşim kurabilme imkânı sağlamalarıdır. Nesnelerin özelliklerini değiştirilerek

özellikler arasındaki ilişkilerin açınmalarına fırsat sunarlar. Daha da önemlisi bu programlar birçok matematiksel ifadeyi görselleştirir. PME-NA 2011 de DIMLE' nin öne çıkan özelliklerinin dinamik ve etkileşimli olduğu ifade edilmiştir. Dolayısıyla bu özellikler matematiği daha iyi öğrenme ve anlama imkânı verir. (Hoyles & Noss, 2009). Bunların yanında DIMLE' nin sunduğu öğrenme türleri ise görsel, açınarak ve dinamik öğrenmedir. (Karadağ, Aktumen, 2013)

YÖNTEM

2.1. Araştırmanın Modeli

Eylem araştırması (Yıldırım & Şimşek, 2013, s.84) uygulamada ortaya çıkan sorunların anlaşılmasına ve çözülmesine yönelik uygulayıcıların uygulama süreçlerini çalışmasını içerdiğinden bu çalışmada nitel araştırmanın bir deseni olan eylem araştırması kullanılmıştır.

2.2. Araştırmanın Örnekleme

Araştırmanın örneklemini Bayburt iline bağlı bir taşınmalı bir köy okulundaki yedinci sınıf öğrencilerinden seçilen beş öğrenci oluşturmaktadır.

2.3. Veri Toplama Araçları ve İşlem

Dinamik ve Etkileşimli Öğrenme Ortamı olan GeoGebra kullanılarak çalışma yaprakları hazırlanmış, bu çalışma yapraklarını kullanacakları ders modeli hazırlanmış ve her öğrenciye bireysel olarak kullanabilecekleri bilgisayarlar verilmiştir. Ders video kamera ile kayıt altına alınmıştır.

2.4. Verilerin Analizi

Bu çalışmada amacımız topladığımız verileri açıklayabilecek kavramlara ve ilişkilere ulaşmak olduğundan analiz yöntemi olarak içerik analizi kullandık.

BULGULAR

GeoGebra ile hazırlanmış çalışma yaprakları ile oluşturulan ders video kaydına çekilip, bu video kaydı Word belgesine aktarılmış ve aşağıdaki temalar elde edilmiştir. Temalar ve temaların elde edildiği bilgiler aşağıda sırası ile verilmiştir.

Çalışmanın yapıldığı okulun köy okuludur. Dolayısı ile öğrenciler köy çocuklarıdır. Bunlara ek olarak öğretmenleri birçok öğrencilerin sosyoekonomik durumlarının düşük olduğunu bu sebeple birçoğunun bilgisayarı olmadığını ifade etmiş. Öğretmenleri çoğunun bilgisayar kullanmaya karşı korkularının olduğunu hatta öğrencileri seçerken bazılarının bilgisayar kullanmayı bilmediklerini ifade ederek bu çalışmaya katılmamış veya katılmamak istediklerini belirtir. Bunlara ek olarak bu öğrenciler ilk defa bir derste bilgisayarı kendileri kullanarak bir şeyler öğrenmeye çalıştılar. Bu nedenlerden dolayı öğretmen öğrencilerin korkularını kırmak ve derse adapte olmaları için dersin başında rehberlikli öğretim kullanmıştır.

Öğretmen: I noktasını (simetri doğrusu) yakınlaştırıp uzaklaştırdığım da ne gibi bir değişiklik meydana geliyor?

Kemal: Birbirlerine yakınlıkları

Öğretmen: Yakınlaştırdığımda ne oldu?

Kemal: Şekiller birbirine yakınlaştı

Öğretmen: Uzaklaştırdığımda

Kemal: Uzaklaştı

Öğretmen: İkisi de aynı oranda uzaklaştı

...

Öğretmen: Şekil üzerinde başka noktalara da bakalım. Örneğin; A noktası. A noktasının doğruya olan uzaklığı kaç birim?

Öğrenciler: İki birim

Öğretmen: A noktasının simetrisi neresi gizem?

Gizem: A1 noktası

Öğretmen: A1 in doğruya olan uzaklığı kaç birim?

Gizem: İki

Öğretmen: Buradan nasıl bir sonuç çıkarabiliriz? Uzaklıklar?

Öğrenciler: Değişmiyor

Öğretmen: Şeklin gerçeğinin doğruya olan uzaklığı ile simetrisinin doğruya olan uzaklıkları
Sibel: Değişmiyor.

Öğretmen öğrencilerin bilgisayarı kullanmaya alıştıklarını fark ediyor ve öğrencilerin açınısamalarına fırsat vermek için rehberlikli eğitimin miktarını azaltıyor. Öğrenciler yetiştikleri kültür itibarı ile kendi kendilerine açınısamaya alışık olmadıkları için öğretmenleri rehberlikli keşfetme yöntemini seçiyor.

Öğretmen: B harfinin yatay simetrisi var. Peki, Samet dikey simetrisi var mı?

Samet: ?

Öğretmen: Dikey doğruyu hareket ettirdiğinde B harfini simetrik olarak iki eş parçaya bölüyor mu?

Samet: Bölmüyor. O zaman B harfinin dikey simetrisi yoktur demi hocam?

Öğretmen: Evet

...

Öğretmen: S harfinin simetri doğrularını bulalım Abdülmecit

Abdülmecit: S harfinin simetri doğrusu yoktur.

Samet: Vardır.

Öğretmen: Göster bize simetri doğrusunu Samet

Samet: (dikey doğruyu S harfinin ortasına yerleştirir)

Öğretmen: Simetri doğrusu mu?

Samet: Evet

Öğretmen: Üst taraftaki uç noktasının karşıda görüntüsü var mı?

Samet: Yok, alt taraftaki uç noktasının da diğer tarafta görüntüsü yok. Yatay simetrisi de yoktur.

Öğretmen: Kemal S harfinin simetri doğrusu var mı?

Kemal: (dikey doğruyu S harfinin ortasına getirerek) var öğretmenim

Öğretmen: simetri doğrusunu ayna gibi düşünürsek kemal S harfinin üst uç kısmının görüntüsü karşı tarafta nerde olmalı?

Kemal: (simetriği olan yeri gösterir)

Öğretmen: Peki görüntü orda mı?

Kemal: Hayır öğretmenim

Öğretmen: S harfinin alt uç kısmının görüntüsü nerde olacak?

Kemal: (simetriği olan yeri gösterir) ama burada değil yansıması

Öğretmen: Dikey simetrisi var mı?

Kemal: Hayır

Öğretmen: Kemal S harfinin yatay simetrisi var mıdır? Bakar mısın?

Kemal: (yatay doğruyu S harfinin ortasına getirir) öğretmenim yatay simetrisi var

Öğretmen: Kemal doğruyu ayna olarak düşün ve S harfinin uç noktalarına bak simetrikler mi?

Kemal: Evet simetrikler

Öğretmen: Üstteki uç noktanın simetrisini gösterebilir misin?

Kemal: (alttaki uç noktayı gösterir)

Öğretmen: Kemal sen aynaya baktığında kafanı ayaklarının olduğu yerde mi görüyorsun yoksa kafanın karşısında mı?

Kemal: Karşısında.

Öğretmen: (S harfinin uç noktalarını harflendirir) C noktasının görüntüsü nerde olur?

Kemal: (noktanın simetriği olan yeri gösterir) ama burada değil. S harfinin yatay simetrisi yoktur öğretmenim.

Öğretmen: E ve M harflerinin doğruları hareket ettirerek simetri doğrularını bulun.

Sibel: E harfinin yatay simetrisi var

Gizem: M harfinin dikey simetrisi var

Yukarıdaki diyalogları incelediğimizde rehberlikli eğitimin yerini rehberlikli açınısamaya (keşfetmeye) bırakması ile beraber öğrencilerin derse olan katılımlarının da arttırdığı görülmüştür. Bunlara ek olarak yukarıdaki diyaloglar rehberlik miktarının öğrencilerin ihtiyacına göre değişeceğini de göstermektedir.

Dersin sonunda öğretmen ufak bir değerlendirme yapmak için simetri ile ilgili hazırlamış olduğu etkinlik kâğıdını dağıtmış ve öğrencilerden bireysel olarak soruları cevaplamalarını istemiştir.

Öğretmen: İkinci soruyu kim okuyup cevaplıyor?

Sibel: Aşağıda verilen simetritlerden hangisi doğrudur? A şıkkı öğretmenim

Öğretmen: Başka bir fikri olan var mı?

Gizem: A

Samet: A
Abdülmecit: A
Kemal: C

Öğretmen: Hep beraber bakalım her iki şıkka da. A şıkkı doğru. C şıkkı da doğru. Soruda bir yanlışlık mı var?
Kemal: hayır öğretmenim A şıkında ayva kelimesinin yansımada a ve v harfleri doğru yansıtılmış olmalarına rağmen y harfi doğru yansıtılmamıştır.

Yukarıda Kemal' in simetriyi anlamakta zorlandığı ve öğretmenin ona fazlaca rehberlik yaptığı görülmüştür. Dersin sonunda yapılan etkinlikte ise diğer arkadaşlarının ve hocasının göremediğini Kemal fark etmiş ve açıklamıştır. Öğretmeni ile olan görüşmemizde dört hafta sonra yapılan simetri etkinliğinde de bu beş öğrencinin doğru sayılarının fazla olduğu Kemal' in ise soru kaçırmadığını ifade etmiştir. Bu ifadeler de bize etkili öğrenmenin gerçekleştiğini ifade etmiştir.

SONUÇ

Öğrencilerin bilgisayar kullanmaya olan tutumlarından ve derste ilk defa bilgisayar kullanmalarından dolayı öğretmen rehberlikli eğitim kullanmıştır. Dersin başlarında rehberlikli eğitim kullanılması öğrencilerin korkularını azaltmış ve öğrencilerin derse olan motivelerini arttırdığı gözlemlenmiştir. Fakat derse katılımı arttırmadığından, ilerleyen aşamalarda da kullanılması dersi öğrenci merkezli yapmayacağından, derse olan ilgiyi azaltabileceğinden ve açınısama imkânı vermediğinden rehberlikli eğitimin yerini rehberlikli keşfetmeye bırakmış olması olumlu sonuçlara sebep olmuştur. Derse katılımı artmış ve (Gravemeijer, 1998) var olan bilgiyi keşfetme imkânı elde etmişlerdir. Kirschner' in (2006) belirttiği gibi rehberliksiz keşfetme kavram yanlışlarına ve eksik bilgilere sebep olabileceğinden ve yetişmiş olukları kültürün açınısamaya açık olmamasından dolayı ders boyunca rehberlikli keşfetme devam edilmiş fakat bireysel farklılıklardan dolayı her öğrenciye aynı miktarda rehberlik yapılmamıştır. Bu bilgi bize öğretmenin yapacağı rehberlik miktarını ayarlaması için öğrencilerini çok iyi tanması gerektiğini söylemektedir. Aynı zaman da açınısama ile öğrendikleri için etkili öğrenmeyi gerçekleştirmişlerdir. Bunlara ek olarak bu öğrenciler daha sonraki derslerini de bu şekilde işlemek istediklerini öğretmenlerine söylemişler, bu da onların bilgisayar kullanmaya olan korkularının kırıldığını göstermiştir.

Yapmış olduğumuz çalışma yapacağımız çalışmanın pilotu olduğundan sadece simetri konusu ele alınarak yapılmıştır.

ÖNERİLER

Öğrencilerin bilgisayar kullanmaya karşı olumsuz bir tutumları var ise dersin başlarında rehberlikli eğitim kullanılmalı fakat bu süre uzun tutulmamalıdır. Öğrencilerin yetişmiş olduğu kültüre ve öğrencinin bireysel özelliklerine göre rehberlikli ve rehberliksiz keşfetmeden uygun olan seçilmelidir. Öğrencilerin açınısalarına yardımcı olmak ve etkili öğrenmeyi gerçekleştirmek için DIMLE yazılımları derslerde ve yapılan etkinliklerde kullanılmalıdır.

KAYNAKLAR

- Güven, B. (2002). Dinamik Geometri Yazılımı Cabri ile Keşfederek Öğrenme, Yüksek Lisans Tezi, Karadeniz Teknik Üniversitesi, Fen Bilimleri Enstitüsü, Trabzon.
- Gravemeijer, K. P. (1998). *From a different perspective: Building on students' informal knowledge*. R. Lehrer and D. Chazan (eds.) *Designing learning environments for developing understanding of geometry and space*. New Jersey: Lawrence Publishers
- Hoyles, C., & Noss, R. (2009). The technological mediation of mathematics and its learning. *Human Development*, 52(2), 129-147.
- Karadağ, Z., & Aktumen, M. (2013). Preface. *Mevlana International Journal of Education*. Vol. 3(3), pp. i-iv. <http://dx.doi.org/10.13054/mije.si.2013.00>
- Karadağ, Z., Martinovic, D., & Freiman, V. (2011). Dynamic and Interactive Mathematics Learning Environments (DIMLE). In L. R. Wiest, & T. Lamberg (Eds.), *The Proceedings of the 33rd Annual Meeting of the North American Chapter of the International Group for the Psychology of Mathematics Education*. Reno, Nevada.

Kirschner, P. A., Sweller, J., & Clark, R.E. (2006) *Why Minimal Guidance During Instruction Does Not Work: An Analysis of the Failure of Constructivist, Discovery, Problem-Based, Experiential, and Inquiry-Based Teaching*, *Educational Psychologist*

Yıldırım.A., Şimşek.H., (2013) *Sosyal Bilimlerde Nitel Araştırma Yöntemleri* , Ankara: Seçkin

ÇEVRE EĞİTİMİ PROJESİNİN¹ ÖĞRENCİLERİN BİLİŞSEL YAPILARI ÜZERİNE ETKİSİ

Doç. Dr. Sacit KÖSE
Pamukkale Üniversitesi, Eğitim Fakültesi, Biyoloji Eğitimi ABD
sacitk@pau.edu.tr

ÖZET: İçinde bulunduğumuz yüzyılın en büyük sorunların biri de hiç şüphesiz çevre ve çevre kirliliğidir. Bu sorun ülkemizde de her geçen gün istenmedik boyutlara ulaşmaktadır. İnsanoğlunun yaşam biçimi, doğal kaynakları sınırsız ve dikkatsiz bir şekilde kullanması, atıkların bilinçsizce çevreye atılması ve eğitimsizlik bu sorunun temel nedenleri olarak karşımıza çıkmaktadır. Bu sorunun farkına varıp çözümler üretebilmek ancak iyi bir çevre eğitimi ile mümkün olacaktır. Bu çalışma; TÜBİTAK 4004 - Doğa Eğitimi ve Bilim Okulları proje grubunda yer alan 113B141 nolu “Çevre Dedektifi Horoz İş Başında -2” isimli projenin, 5. sınıf öğrencilerinin içinde yaşadıkları çevre ve çevre sorunlarına yönelik bilişsel yapıları üzerine etkisini belirlemek amacıyla yapılmıştır. Çalışmada deneysel desenlerden “Tek grup ön test-son test modeli” kullanılmıştır. Çalışma grubunda, Denizli il merkezindeki bir okulda 5. sınıfa geçen 25 öğrenci, velileri ve iki sınıf öğretmeni yer almıştır. Projede öğrencilerin yaparak-yaşayarak ve eğlenerek öğrenmelerini sağlamak amacıyla, seviyelerine uygun olarak hazırlanmış çevre ve çevre sorunlarına yönelik 45 etkinlik farklı öğretim yöntemleri (senaryo, oyun, gezi-gözlem, deney) kullanılarak gerçekleştirilmiştir. Çalışmada öğrencilerin çevre ve çevre sorunları ile ilgili bilişsel yapılarını ve bundaki değişimi belirlemek amacıyla kelime ilişkilendirme testi proje başında ve sonunda ön test ve son test olarak uygulanmıştır. Bu testi oluşturmak amacıyla konulara uygun 11 tane anahtar kavram (çevre kirliliği, erozyon, toprak kirliliği, atık pil, geri dönüşüm, su kirliliği, hava kirliliği, çöp, sera etkisi, asit yağmuru, enerji) seçilmiştir. Bu kavramlar konunun üzerine inşa edildiği ve konu için en önemli olduğu düşünülen kavramlardır. Elde edilen bulgular, proje uygulandıktan sonra tüm anahtar kavramlarla ilişkilendirilen cevap kelimelerin sayısında büyük oranda artış olduğunu göstermiştir. Ayrıca ön testte görülen kavram yanlışlarının belirli oranda son testte giderildiği belirlenmiştir. Çalışma sonunda, uygulanan çevre eğitimi projesinin öğrencilerin anlamlı öğrenmelerine katkıda bulunduğu ve bilişsel yapılarını geliştirdiği sonucuna varılabilir. Bu sonuç yürütülen projenin etkililiğini ortaya koymaktadır.

Anahtar sözcükler: çevre sorunları, çevre eğitimi, proje, bilişsel yapı, 5. sınıf öğrencileri

1



<http://cevrecihoroz.pau.edu.tr/>

ANALYSIS OF PRESERVICE ELEMANTARY TEACHERS VISUAL MATHEMATICS LITERACY

Assist. Prof. Dr. Selcen ÇALIK UZUN
Artvin Çoruh University, Faculty of Education, Elemantary Education Department
sclkuzun@artvin.edu.tr

Research Assist. Sedef ÇELİK
Artvin Çoruh University, Faculty of Education, Elemantary Education Department
sedefcelik@artvin.edu.tr

Features expected from individuals by today's world, which keeps step with scientific developments, changes day by day. It becomes more important to adapt and use acquired information in daily life and individuals who are equipped with interpretation, analysis, problem solving abilities are needed more. This situation is reflected to education programs, and it is seen that at the end of learning process, students are expected to have mental process skills. It is possible to gather these significant points under the title of 'literacy'. It is known that the meaning of the concept of literacy has been broadened and today literacy means having the above mentioned abilities besides acquiring reading-writing skills. When it is thought that learning occurs in different disciplines, branching of the concept of literacy specifically in some disciplines becomes inevitable. Computer literacy, mathematics literacy, television literacy, science literacy and visual literacy are some of these branches. This research focuses on visual mathematics literacy, which is the intersection of mathematics and visual literacy and the goal of this research is to analyze visual mathematics literacy levels of classroom teacher candidates.

The research is designed as a survey model. Participants of this research are 2nd grade students in Education Faculty, Classroom Teaching Department of a university in Eastern Black Sea Region. They are determined as candidate teachers who take the lessons of Basic Mathematics-, Basic Mathematics-2.

Data are obtained through ten open ended questions which are prepared according to the Mathematics I or II classes topics' learning outcomes that are proper for determining mathematics visual literacy; expert opinions on these questions are taken. After the pilot study, aiming at determining if questions are clear and understandable, 1 question is removed from the study. Reliability of the study is attempted to be ensured by analyzing separately by two researchers with the help of evaluation form prepared by researchers. According to the obtained data, it can be said that, preservice elementary teachers can not completely and accurately express visual mathematic expressions verbally as they can not use the mathematical terminology successfully.

Key Words: Visual Mathematics Literacy, Mathematical Literacy, Mathematical Expression, Classroom Teacher Candidates

TEKNOLOJİ DESTEKLİ ÇOKLU TEMSİL TEMELLİ ÖĞRETİME ÖRNEK BİR UYGULAMA

AN EXAMPLE APPLICATION OF TECHNOLOGY-ASSISTED MULTIPLE REPRESENTATION-BASED INSTRUCTION

Dilek İZGİOL

Dokuz Eylül Üniversitesi, Eğitim Bilimler Enstitüsü
dilekizgiol90@gmail.com

Doç. Dr. Cenk KEŞAN

Dokuz Eylül Üniversitesi, Buca Eğitim Fakültesi
cenk.kesan@deu.edu.tr

Deniz KAYA

Dokuz Eylül Üniversitesi, Eğitim Bilimler Enstitüsü
denizkaya50@yahoo.com

ÖZET: Bu araştırmanın amacı ilköğretim matematik öğretmen adaylarının lisans düzeyinde aldıkları lineer cebir dersine yönelik teknoloji destekli çoklu temsil temelli bir öğretim uygulaması hazırlamaktır. Çalışma, Dokuz Eylül Üniversitesi, Buca Eğitim Fakültesi, İlköğretim Matematik Öğretmenliği Bölümü'nde öğrenim görmekte olan 45 öğretmen adayı ile gerçekleştirilmiştir. Bu öğretim uygulamasında, çoklu temsil temelli öğretime uygun olarak bilgisayar ortamında hazırlanan videolar ve derse ilişkin konu anlatımı kaynakları uzaktan eğitimde kullanılmak üzere öğrencilere internet üzerinden erişime açılmıştır. Öğrencilerin sistemdeki kaynakları incelemeleri için belirtilen süre sona erdikten sonra, kararlaştırılan zaman diliminde internet ortamında uzaktan eğitim ile öğrencilerle birlikte dersin işlenişi gerçekleştirilmiştir. Bu öğretim uygulaması sonucunda, teknoloji destekli çoklu temsil temelli öğretimle lineer cebir dersinin uzaktan eğitim ile başarılı bir şekilde uygulanabileceği görülmüştür. Ancak uzaktan eğitim sırasında tüm öğrencilerin derse katılımını sağlama sürecinde bazı güçlüklerin yaşanabileceği tespit edilmiştir.

Anahtar sözcükler: uzaktan eğitim, çoklu temsil temelli öğretim, teknoloji destekli eğitim, lineer cebir öğretimi, ilköğretim matematik öğretmen adayı

ABSTRACT: The purpose of this study was to prepare and implement an application of the technology-assisted multiple representation-based instruction for linear algebra that primary mathematics pre-service teachers take at undergraduate education. The study was performed with 45 pre-service teachers receiving education at Dokuz Eylul University, Faculty of Education, Department of Primary Mathematics Education. In this education mode, videos prepared in accordance with multiple representation-based instruction in computer environment and resources related to the lessons uploaded to internet to be used in distance education. After the expiration of the time given students to examine the resources in the distance education environment, the linear algebra course was carried out with pre-service students via distance education environment at the appointed time. As a result of this education mode, it was seen that linear algebra course can be successfully carried out via the distance education. On the other hand, it was determined that teachers can have some difficulties about the students' participation of the distance education course.

Key words: distance education, multiple representation-based instruction, technology-assisted education, linear algebra teaching, primary mathematics pre-service teachers.

GİRİŞ

Temsil kavramı matematik eğitimindeki etkisi ve önemi üzerinde durulan bir terimdir. Temsil, herhangi bir matematik probleminin, çeşitli zihinsel faaliyetler sonucunda ilk olarak zihinde sonrasında, eylemsel olarak farklı bir yolla ifade edilmesidir. Temsiller temel olarak iç ve dış temsil olmak üzere ikiye ayrılır. İç temsil, bilişsel süreç sonunda zihinde oluşturulan sembollerdir. Dış temsil ise oluşturulan iç temsilin davranışa dönüştürülmesiyle elde edilen sembollerdir. Bireylerin oluşturdukları iç temsiller doğrudan değerlendirilemez, ancak oluşturulan dış temsiller yardımıyla değerlendirilebilirler. Bu nedenle yapılan araştırmalarda dış temsiller ele alınmaktadır. Matematik eğitiminde kullanılan dış temsille karşılaştırıldığında, birden çok dış temsilin aynı

durumda birlikte kullanılması (çoklu dış temsiller (ÇDT)) öğrenme düzeyini arttırabilir ve eğitimi daha da zenginleştirmektedir.

Matematik eğitiminde ÇDT kullanılması öğrenme kalitesini arttırır. Matematiksel kavramları anlamlandırma, birbiriyle ilişkilendirme ve etkili bir şekilde kullanabilme, ÇDT kullanabilme ve aralarındaki geçişleri yapabilmeye yakından ilişkilidir (Bossé, Adu-Gyamfi ve Cheetham, 2011). ÇDT ile zenginleştirilmiş matematik öğretimi uygulamalarında öğrencilerin başarıları artar (Akkuş Çıkla, 2004). Öğrenmede çoklu temsile yer verilmesi öğrencilerin matematiğe olan ilgisini arttırır (Durkaya, 2011). Öğretmenler ders zamanından tasarruf sağlar, daha çok çeşitteki temsillere yer verirler, kalan zamanda öğrenciler temsiller arasındaki bağları kurma ve analizleri yapma ile ilgilenebilirler, ayrıca teknoloji destekli temsillerle biçimlendirici değerlendirme yapabilirler (Fraser, 2010).

Öğretmenler çoklu temsilleri içeren çeşitli tekniklerle ders işlenişini gerçekleştirmeli, öğrencilerin temsillerle pratik yapmalarına olanak sağlamalı, öğrencilerin çoklu temsilleri düşünme, açıklama ve değerlendirme için bir araç olarak görmelerini sağlamalıdır (Pape ve Tchoshanov, 2011). Öğretmenler, öğrencilerin matematiksel kavramları daha iyi öğrenmesi ve matematiksel süreçlerde bilinçli ve akıcı hareket edebilmesi için, çoklu temsiller arasında bağlantılar kurulabilecek fırsatlara sahip olan öğrenme ortamları tasarlamalıdır (Wood ve diğ., 2007).

Öğrencilerin matematik başarılarını artırmanın anahtarlarından biri ÇDT' dir. Öğrencilerin ÇDT kullanım becerilerine sahip olması için, onlara matematik eğitimini verecek olan öğretmenlerin ÇDT konusunda tam donanımlı olması ve ÇDT'yi matematik eğitiminde uygun şekilde kullanma becerilerine sahip olması gerekir. Ancak yapılan araştırmalar sonucunda öğretmen adaylarının ÇDT ve kullanımı konusunda sınırlı bilgi ve becerilere sahip oldukları görülmektedir. Bunun yanı sıra öğretmen adaylarının ÇDT ile ilgili becerilerini arttırmaya yönelik yapılan çalışmaların az olduğu tespit edilmiştir. Bu nedenle bu çalışmanın amacı, öğretmen adaylarının ÇDT bilgilerini ve ÇDT kullanım becerilerini arttırmayı sağlayacak örnek bir öğretim uygulaması hazırlamaktır.

TeÇoLi: Teknoloji Destekli Çoklu Temsil Temelli Lineer Cebir Öğretimi Uygulaması

TeÇoLi İlköğretim Matematik Öğretmenliği Bölümü'nde ikinci sınıfta alınan Lineer Cebir dersi konularından ortagonallik ve ortanormallik, Gram-Schmidt yöntemi konuları temel alınarak hazırlanmıştır. Uygulama konuya ilişkin hazırlanan sunum, cebirsel, sözlü ve grafik temsiller (bilgisayar cebir sistemiyle hazırlanan 2 ve 3 boyutlu grafikler) ile zenginleştirilmiştir. Grafik temsillerin hazırlanmasında Mathematica ve GeoGebra yazılımları kullanılmıştır. Bilgisayar ortamında hazırlanan materyaller, yine bilgisayar ortamında araştırmacı tarafından sağlanan sesli konu anlatımı desteğiyle sunum ve grafik temsiller kullanılarak video formatında kaydedilmiştir. Hazırlanan tüm ders videoları, yazılımlarda hazırlanan grafik temsiller, konu anlatım sunumları, Dokuz Eylül Üniversitesi Uzaktan Eğitim Uygulama ve Araştırma Merkezi (DEUZEM) tarafından sağlanan DE-OYS uzaktan eğitim ortamına yüklenmiştir. DE-OYS aracılığıyla ilgili ders konularının cebirsel temsilleri içeren sunumlar ve grafik temsilleri içeren yazılımlarda hazırlanan uygulamalar ve sözlü temsili içeren videolar internet üzerinde öğrencilerin erişimine açılmıştır. Sistemde bulunan matematik yazılımlarıyla hazırlanmış grafik temsilleri yardımıyla öğrencilere temsilleri farklı temsillere dönüştürme şansı verilmiştir. TeÇoLi' deki grafik temsilleri üzerinde değişiklik yaparak elde edilecek farklı temsillerin konuyu öğrenme seviyesini olumlu yönde etkileyeceği düşünülmüştür.

Öğrencilere ilgili konunun haftasında, konuya ilişkin dosyaların erişimi sağlanmıştır. Belirlenen gün ve saatte ise sistemdeki kaynakları önceden taramış olan öğrenciler ve araştırmacı uzaktan eğitim platformunda bir araya gelerek anlaşılmayan noktaları, dersin sistemindeki kişiler tarafından görülen bir sohbet ortamında tartışmışlardır. Ayrıca öğretmen adayları ve araştırmacı sınıf ortamında bir araya gelerek işlenen konuları tekrar gözden geçirmişlerdir.

TeÇoLi de Kullanılan Cebirsel Temsil

Araştırmada ele alınan ortagonallik-ortanormallik ve Gram-Schmidt ortanormalleştirme yöntemlerinin doğası gereği, çalışmada cebirsel temsile yer verilmiştir. Cebirsel temsile, gerek hazırlanan sunumda gerekse de kullanılan yazılımlarda yer verilmiştir. Şekil 1 de gösterildiği üzere cebirsel temsiller vektör kümelerinin ortagonallik-ortanormallik testinde ve Gram-Schmidt ortanormalleştirme yöntemlerinin vektör kümelerine uygulamalarında kullanılmıştır.

Örnek 1:

\mathbb{R}^2 de $S = \{u_1 = (1,3), u_2 = (2,-1)\}$ tabanı yardımıyla \mathbb{R}^2 nin herhangi bir ortonormal tabanını bulunuz.

Çözüm: (2. Temsil)

$K = \{v_1, v_2\}$ ortogonal tabanı olsun.

$v_1 = (1,3)$ olsun.

$$v_2 = u_2 - \frac{\langle u_2, v_1 \rangle}{\langle v_1, v_1 \rangle} v_1 = (2, -1) - \frac{\langle (2,1), (1,3) \rangle}{\langle (1,3), (1,3) \rangle} (1,3) = (2, -1) - \frac{-1}{10} (1,3) = \left(\frac{21}{10}, \frac{-7}{10} \right) = \frac{7}{10} (3, -1)$$

$\langle u, v \rangle = 0$ ve $\langle u, r.v \rangle = 0$ olduğundan

$\langle v_1, v_2 \rangle = \langle (1,3), \frac{7}{10} (3,-1) \rangle = 0 = \langle (1,3), (3,-1) \rangle$ dir ve $v_2 = (3,-1)$ alınabilir.

$K = \{v_1 = (1,3), v_2 = (3,-1)\}$ ortogonal tabandır. Buradan;

$$L = \left\{ \frac{1}{\|v_1\|} v_1 = l_1, \frac{1}{\|v_2\|} v_2 = l_2 \right\} = \left\{ \frac{1}{\sqrt{10}} (1,3), \frac{1}{\sqrt{10}} (3,-1) \right\}$$
 ortonormal taban elde edilir.

Şekil 1. \mathbb{R}^2 de Herhangi Bir Tabana Uygulanan Gram-Schmidt Yönteminin Cebirsel Temsili

$K = \{v_1, v_2, v_3\}$ ortogonal taban olsun.

$v_1 = u_1 = (1,3,1)$ olsun.

$$v_2 = u_2 - \frac{\langle u_2, v_1 \rangle}{\langle v_1, v_1 \rangle} v_1 = (2,2,0) - \frac{\langle (2,2,0), (1,3,1) \rangle}{\langle (1,3,1), (1,3,1) \rangle} (1,3,1) = (2,2,0) - \frac{8}{11} (1,3,1) = \left(\frac{14}{11}, \frac{-2}{11}, -\frac{8}{11} \right) = \frac{2}{11} (7, -1, -4)$$

$v_2 = (7, -1, -4)$ olarak alabiliriz.

$$v_3 = u_3 - \frac{\langle u_3, v_1 \rangle}{\langle v_1, v_1 \rangle} v_1 - \frac{\langle u_3, v_2 \rangle}{\langle v_2, v_2 \rangle} v_2 = (-1,0,2) - \frac{\langle (-1,0,2), (1,3,1) \rangle}{\langle (1,3,1), (1,3,1) \rangle} (1,3,1) - \frac{\langle (-1,0,2), (7,-1,-4) \rangle}{\langle (7,-1,-4), (7,-1,-4) \rangle} (7,-1,-4) \\ = (-1,0,2) - \frac{1}{11} (1,3,1) - \frac{-15}{66} (7,-1,-4) = \left(-1 - \frac{1}{11} + \frac{35}{22}, 0 - \frac{3}{11} - \frac{5}{22}, 2 - \frac{1}{11} - \frac{20}{22} \right) = \left(\frac{11}{22}, -\frac{11}{22}, \frac{22}{22} \right) \\ = \frac{11}{22} (1, -1, 2)$$

$v_3 = (1, -1, 2)$ olarak alınabilir.

$K = \{v_1 = (1,3,1), v_2 = (7,-1,-4), v_3 = (1,-1,2)\}$ bulunur.

$$L = \left\{ \frac{1}{\sqrt{11}} (1,3,1), \frac{1}{\sqrt{66}} (7,-1,-4), \frac{1}{\sqrt{6}} (1,-1,2) \right\}$$
 dir.

Şekil 2. \mathbb{R}^3 de Herhangi Bir Tabana Uygulanan Gram-Schmidt Yönteminin Cebirsel Temsili

Geleneksel öğretim yöntemlerinde cebirsel temsil kullanılmaktadır. Sadece bu temsilin Lineer Cebir öğretiminde kullanılması, öğrencilere soyut gelen bu dersin anlaşılmasını zorlaştırmaktadır. Öğrenmeyi kolaylaştırmak için farklı çeşitlerde temsillerle öğretim etkinlikleri desteklenmelidir. Bu sebeple grafik temsillerine de çalışmada yer verilmiştir. Ancak temsillerin sunumundaki sıralamaya dikkat edilmelidir. Bu çalışmada cebirsel temsillerin grafiksel temsillerden önce sunulması uygun görülmüştür.

TeÇoLi de Kullanılan Grafiksel Temsil

Öğrencilere sunulan cebirsel temsillerin grafiksel temsil modları Mathematica ve GeoGebra yazılımlarında 2 ve 3 boyutlu grafikler halinde hazırlanmıştır. Yazılımların sunduğu imkanlar doğrultusunda, temsillerin hareket ettirilebilir olması, vektörler arasındaki açının hesaplanarak gerçekten de ortogonalite testinin sağlandığının teyit edilebilmesi ve vektör normlarının hesaplanarak ortonormalite testinin yapılabilmesi bu temsillerin öğrenmeyi artırıcı özelliklerini desteklemektedir.

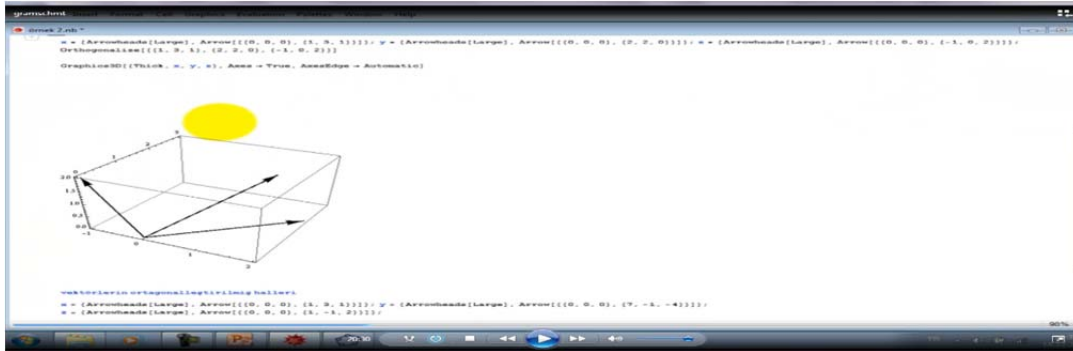

Şekil 3. \mathbb{R}^3 ün Herhangi Bir Tabanını Temsil Eden 3 Boyutlu Grafik Temsili

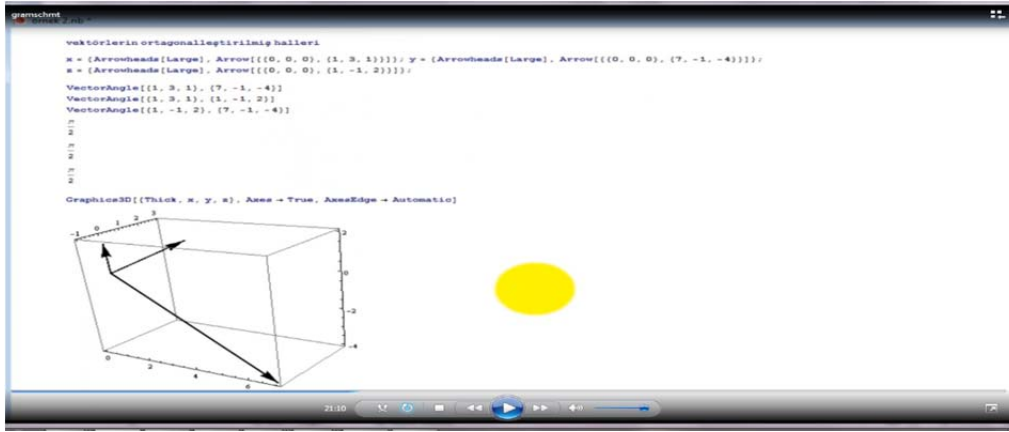

Şekil 4. \mathbb{R}^3 de Herhangi Bir Tabana Uygulanan Gram-Schmidt Yöntemiyle Elde Edilen Ortogonal Tabanı Temsil Eden 3 Boyutlu Grafik Temsili

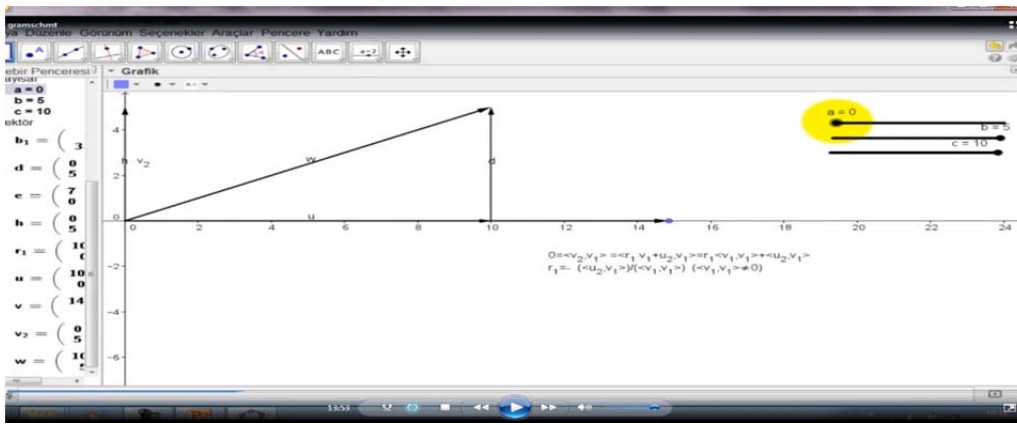

Şekil 5. 2 Boyutlu Grafik Temsili ve Cebirsel Temsil

SONUÇ

Genel olarak farklı yaş gruplarındaki öğrencilerin çoklu temsillerle ilgili becerilere yeterli düzeyde sahip olamama sorunlarını ortadan kaldırmak için öğretmenlerin, dolayısıyla öğretmen adaylarının bu konudaki eksiklikleri giderilmelidir. Bu ihtiyaca yönelik olarak çalışmada, ilköğretim matematik öğretmen adaylarının seviyesine uygun olarak, lisans öğreniminde ikinci sınıfta aldıkları Lineer Cebir dersinin bazı konularına yönelik TeÇoLi hazırlanmıştır. TeÇoLi’de cebirsel, sözel ve grafiksel temsillere birlikte yer verilmiştir. Soyut kavramlar içeren Lineer Cebir dersinin zihinde somutlaştırılmasını kolaylaştırmak için uygulamanın hemen hemen her materyalinde teknolojik destek alınmıştır. Teknoloji, Lineer Cebir’in uzun işlemlerini kısaltma göreviyle değil, asıl olarak öğrenmeyi destekleyecek işlevler üstlenerek uygulamanın önemli bir parçası haline getirilmiştir. Uygulamada yer alan cebirsel ve grafiksel temsillerin öğrencilere aktarılmasında, öncelikle cebirsel temsillerin sunumu sonrasında ise grafiksel temsillerin sunumu şeklinde bir sıra izlenmiştir. Bunun sebebi, önce grafiksel temsillerin sunulması durumunda kavram karmaşasına yol açabileceği düşünülmüştür. Yapılan uzaktan eğitim dersleriyle zaman ve mekândan tasarruf sağlanarak, öğrencilere daha fazla çoklu temsillerle çalışma imkânı sunulmuştur. Gerçekleştirilen Lineer Cebir öğretiminde öğrencilerin derse katılım performanslarının yüksek olduğu gözlemlenmiştir ve bunun sebebinin kullanılan çoklu temsiller ve teknoloji desteğinin öğrencilerin derse karşı motivasyon düzeylerini arttırdığı düşünülmektedir. TeÇoLi’ nin üç haftalık uygulanması sonrasında, öğrencilerin sahip olduğu bu kadar soyut kavramlar içeren Lineer Cebir dersinin uzaktan eğitimle işlenmemesi gerektiği düşüncesi, yerini dersin uzaktan eğitimle daha anlaşılır bir şekilde işlenebileceği düşüncesine bırakmıştır. Öğrencilerin derse olan ilgisinin olumlu olarak arttığı gözlemlenmiştir. Ayrıca öğrenciler uygulama sonunda, dersle ilgili fikirlerini sunarken, kullanılan çoklu temsillerin dersi daha iyi anlamalarına yardımcı olduğunu ve çoklu temsilleri öğretmen olduktan sonra öğrencilerin başarılarını arttırmak için kullanacaklarını belirtmişlerdir.

TeÇoLi sürecinde uzaktan eğitim sistemine yüklenen ders videolarının önceden öğrenciler tarafından izlenmesi ve anlaşılmayan yerlerin not edilerek derste araştırmacıya sorulması istenmiştir. Ancak öğrencilerin ders videosunu izlerken anlamadıkları noktaları anında bir uzmana sorma şanslarının olmaması nedeniyle öğrenciler

bir takım sorunlar yaşamışlardır. Ayrıca uzaktan eğitim platformunda kilit noktanın internete erişim kalitesidir, fakat bazı öğrencilerin internete erişimde yaşadığı sorunlar bu çalışmanın olumsuz yönlerinden biridir. Son olarak uzaktan eğitimde öğrencilerin internet üzerinden derse katılımını takip etme konusunda bir takım sorunlar yaşanmıştır. Bu sorun uygulama sırasında tüm öğrencilere konu ile ilgili sorular sorup öğrencilerin dikkatlerinin dağılmasını sağlanmaya çalışarak giderilmeye çalışılmıştır.

ÖNERİLER

TeÇoLi’de öğrencilerin Lineer Cebir dersine katılım performanslarını arttırması ve derse olan bakış açılarını olumlu etkilemesi sebebiyle araştırmacılara ve Lineer Cebir dersini veren öğretim elemanlarına örnek bir çalışma olabilir. TeÇoLi’de kullanılan çoklu temsiller çeşitlendirilerek daha etkili öğretim çalışmaları yapılabilir. Çalışmada kullanılan teknoloji destekli çoklu temsil temelli öğretim yöntemi, matematiğin bu yönüne uygun olan diğer alanlarında kullanılmasına yönelik çalışmalar yapılabilir. Uzaktan eğitim sürecinde öğrencilerin bilgisayardaki dikkatlerinin dağılmasını önleyici kriterleri bulmaya yönelik araştırmalar yapılabilir. Günümüz eğitim sisteminde yapılan internet tabanlı eğitim uygulamalarının bir gereği olarak internete erişim kalitesinin arttırılması gerekmektedir.

Teşekkür: Bu çalışmamızın uzaktan eğitim sistemi desteğini sağlayan Prof. Dr. Vahap TECİM ve Uzm. Emre KARAGÖZ başta olmak üzere Dokuz Eylül Üniversitesi Uzaktan Eğitim Uygulama ve Araştırma Merkezi’ne (DEUZEM) teşekkürlerimizi sunarız.

KAYNAKLAR

- Akkuş Çıkla, O. (2004). The effects of multiple representations-based instruction on seventh grade students’ algebra performance, attitude toward mathematics, and representation preference. Unpublished Ph. D. dissertation, The Graduate School of Natural and Applied Sciences of Middle East Technical University, Ankara.
- Bossé, M. J., Adu-Gyamfi, K., and Cheetham, M. (2011). Translations among mathematical representations: teacher beliefs and practices. *International Journal of Mathematics Teaching and Learning*. Retrieved 25 April 2014 from <http://www.cmit.plymouth.ac.uk/journal/default.htm>.
- Durkaya, M. (2011). Visualization approach in teaching process of linear algebra. *Procedia Social and Behavioral Sciences*, 15, 4040-4044.
- Fraser, V. A. (2010). The use of technology-generated representations in mathematics instruction: a study of novice teachers’ practices. Unpublished Ph. D. dissertation, University of Virginia.
- Pape, S. J., and Tchoshanov, M. A. (2011). The role of representation(s) in developing mathematical understanding. *Theory into Practise*, 40(2), 118-127.
- Wood, L. N., Joyce, S., Petocz, P., & Rodd, M. (2007). Learning in lectures: multiple representations. *International Journal of Mathematical Education in Science and Technology*, 38(7), 907-915.

TEKNOLOJİ DESTEKLİ ÇOKLU TEMSİL TEMELLİ ÖĞRETİMİN ÖĞRENCİLERİN LİNEER CEBİR BAŞARISINA ETKİSİ

THE EFFECT OF TECHNOLOGY-ASSISTED MULTIPLE REPRESENTATION-BASED INSTRUCTION ON STUDENTS' LİNEAR ALGEBRA SUCCESS

Dilek İZGİOL

Dokuz Eylül Üniversitesi, Eğitim Bilimler Enstitüsü
dilekizgiol90@gmail.com

Doç. Dr. Cenk KEŞAN

Dokuz Eylül Üniversitesi, Buca Eğitim Fakültesi
cenk.kesan@deu.edu.tr

ÖZET: Bu araştırmanın amacı, teknoloji destekli çoklu temsil temelli lineer cebir öğretiminin, ilköğretim matematik öğretmen adaylarının lineer cebir başarılarına etkisini incelemektir. Çalışma, Dokuz Eylül Üniversitesi, Buca Eğitim Fakültesi, İlköğretim Matematik Öğretmenliği Bölümü'nde öğrenim görmekte olan 73 öğretmen adayı ile gerçekleştirilmiştir. Araştırmada Son-test Kontrol Gruplu Seçkisiz Desen kullanılmıştır. Araştırma sonucunda, teknoloji destekli çoklu temsil temelli lineer cebir öğretimini alan öğretmen adaylarının lineer cebir başarı testi puanlarının, geleneksel öğretimle lineer cebir dersini alan öğretmen adaylarının lineer cebir başarı testi puanlarından anlamlı derecede daha yüksek olduğu görülmüştür.

Anahtar sözcükler: teknoloji destekli eğitim, çoklu temsil temelli öğretim, lineer cebir öğretimi, lineer cebir başarıları, ilköğretim matematik öğretmen adayı.

ABSTRACT: The purpose of this study was to investigate the effects of technology-assisted multiple representation-based linear algebra instruction on linear algebra success of primary mathematics pre-service teachers. The study was performed with 73 pre-service teachers receiving education at Dokuz Eylul University, Faculty of Education, Department of Elementary Mathematics Education. Post-test control group experimental design was used in the research. According to research results, linear algebra achievement test scores of the pre-service teachers taking the technology-assisted multiple representation-based linear algebra instruction were significantly higher than those of pre-service teachers taking the conventional linear algebra instruction.

Key words: technology-assisted education, multiple representation-based instruction, linear algebra teaching, linear algebra success, primary mathematics pre-service teachers.

GİRİŞ

Matematik kavramlarını derinlemesine öğrenebilmek için çoklu temsiller matematiğin anahtarıdır. Çoklu temsillerin kullanıldığı öğrenme ortamlarının sağlanmasıyla öğrenciler, alternatif temsilleri deneyerek hangilerinin kendi öğrenme stillerine daha yakın olduğuna karar verebilirler (Mallet, 2007). Çoklu matematiksel temsillerin kullanımı öğrencilerin matematiksel kavram anlayışlarını destekler ve teknolojik müdahale, somut işlemde soyut düşünmeye geçişi arttıran ve sürekli öğrenme için temel sağlayan temsillerin çoklu kullanımına olanak sağlar (Ozel, Capraro ve Yetkiner, 2008). Öğrenme ortamlarında çoklu temsillerin kullanılmasıyla öğrencilerin temsilleri kullanabilme becerileri ve derse olan tutumları olumlu yönde gelişir (Wong, Yin, Yang ve Cheng, 2011).

Ortaokul seviyesindeki öğrencilerle çoklu temsil kullanım becerilerini araştırmaya yönelik yapılan çalışmalarda öğrencilerin çoklu temsil kullanım becerilerine ve temsiller arası ilişkilendirme ile geçiş becerilerine yeterli düzeyde sahip olmadıkları görülmüştür (Neria ve Amit, 2004; Sert, 2007). Bunun yanı sıra matematik öğretmen adaylarının da temsillerle ilgili beceriler bakımından olmaları gereken seviyeye ulaşamadıkları görülmüştür (Durkaya ve diğ., 2011; Delice ve Sevimli, 2010).

Araştırmanın Amacı

Eğer ortaokul düzeyindeki öğrencilerin iletişim becerilerinin artması için çoklu temsil kullanımı ve aralarında geçiş yapabilmeye becerilerini kazanmalarını istiyorsak, ilgili konuda pedagojik alan bilgisine sahip olan

öğretmenlere ihtiyacımız vardır. Yani çoklu temsiller konusunda donanımlı öğretmenler yetiştirmek gerekir. Bu nedenle gerçekleştirilecek olan çalışma çoklu temsil kullanım becerilerini öğretmen adaylarına kazandırmak açısından önemlidir. Bu çalışmada, teknolojinin desteğiyle soyut ifadeleri somut hale getirerek ve lineer cebir dersini kalabalık işlemlerden kurtararak, öğrencilerin kavramsal öğrenme düzeylerini arttırmak için lineer cebir öğretimi teknoloji destekli çoklu temsil öğretimiyle (TeÇoLi) gerçekleştirilecektir. Böylece ilköğretim matematik öğretmeni adaylarının lineer cebir dersindeki başarılarını arttırmak hedeflenmektedir. Çalışma sonunda öğrencilerin teknoloji destekli çoklu temsil temelli lineer cebir öğretiminin dersteki anlama düzeylerine ve başarılarına olan olumlu etkisinin farkına vararak, bu uygulamanın önemini anlamaları ve yöntemi çeşitli derslere entegre ederek ileride kendi öğrencilerine de uygulama düşüncesine sahip olmaları amaçlanmaktadır.

Araştırmanın problemi; teknoloji destekli çoklu temsil öğretimiyle gerçekleştirilen Lineer Cebir öğretimi ile geleneksel öğretim yöntemleriyle gerçekleştirilen Lineer Cebir öğretimine göre öğrencilerin başarılarında farklılık olup olmadığını belirlemektir.

TeÇoLi: Teknoloji Destekli Çoklu Temsil Temelli Lineer Cebir Öğretimi Uygulaması

TeÇoLi Lineer Cebir dersine yönelik hazırlanmış, cebirsel, sözlü ve grafik temsilleri ihtiva eden teknoloji destekli hazırlanmış bir öğretim uygulamasıdır. Uygulamanın içeriği Lineer Cebir'in ortagonallik, ortanormallik ve Gram-Schmidt yöntemi konularına yönelik hazırlanmıştır. Soyut kavramlar içeren Lineer Cebir dersinin öğrenilmesini kolaylaştırmak ve başarıyı arttırmak için konu anlatımı çoklu temsillerle desteklenmiş ve soyut kavramların somut hale daha kolay transfer edilebilmesi için matematik yazılımlarından Mathematica ve GeoGebra'da hazırlanmış 2 ve 3 boyutlu grafik temsillerine yer verilmiştir. Geleneksel öğretimde de kullanılan cebirsel temsiller bilgisayar ortamında sunum içerisinde yer alırken, grafik temsillerde de desteklenmiştir ve öğrencilerin temsiller arasında ilişki kurabilmesine uygun olarak sıraya konulmuştur. Hazırlanan materyaller kullanılarak bilgisayar ortamında, araştırmacının konu anlatım ses kaydını da içeren konu anlatım videoları hazırlanmıştır. Bu videolarda cebirsel, sözel ve grafik temsiller yer almaktadır. Konu anlatım sunumları, yazılımlarda hazırlanan temsiller ve videolar Dokuz Eylül Üniversitesi Uzaktan Eğitim Uygulama ve Araştırma Merkezi (DEUZEM) tarafından sağlanan DE-OYS uzaktan eğitim ortamına yüklenmiştir. Öğrenciler ilgili konunun sırası geldiğinde, hafta içerisinde internet üzerinden kaynakları tarayıp, belirlenen zamanda uzaktan eğitim dersine katılmışlardır. Sistemdeki sohbet odası platformunda, dersle ilgili taranan kaynaklardan anlaşılmayan noktalar tartışılmıştır. Ayrıca sınıf ortamında konunun önemli bölümleri tekrar edilerek üç haftalık öğretim uygulaması tamamlanmıştır.

YÖNTEM

Araştırmada deneysel araştırma modellerinden Son Test Kontrol Gruplu Seçkisiz Model kullanılmıştır.

Tablo 1. Son Test Kontrol Gruplu Seçkisiz Model

G ₁	M _R	X ₁	O ₁
G ₂	M _R	X ₂	O ₁

G₁: Teknoloji destekli çoklu temsil temelli öğretime dayalı Lineer Cebir öğretiminin uygulandığı grup

G₂: Geleneksel öğretime dayalı Lineer Cebir öğretiminin uygulandığı grup

X₁: Teknoloji destekli çoklu temsil temelli öğretime dayalı Lineer Cebir öğretimi

X₂: Geleneksel öğretime dayalı Lineer Cebir öğretimi

O₁: Son Test (Lineer Cebir Başarı Testi)

Deney grubunda etkisi araştırılacak değişken teknoloji destekli çoklu temsil temelli lineer cebir öğretimi, kontrol grubunda ise geleneksel öğretimle lineer cebir öğretimidir. Araştırmanın bağımlı değişkeni lineer cebir dersindeki başarıdır. Araştırmada Lineer Cebir dersindeki başarıyı belirlemede kullanılmak üzere Lineer Cebir Başarı Testi geliştirilmiştir. Deney grubu ve kontrol grubu arasında Lineer Cebir dersi başarılarına göre anlamlı bir farklılık olup olmadığı, uygulama öncesinde Lineer Cebir dersinin ara sınavından aldıkları puanlar kullanılarak belirlenmiştir..

Katılımcılar

Araştırmanın deneysel kısmında, Dokuz Eylül Üniversitesi Buca Eğitim Fakültesi İlköğretim Matematik Öğretmenliği bölümünde Lineer Cebir dersini alan ikinci sınıfta öğrenim gören 73 öğretmen adayı çalışma grubunu oluşturmaktadır. Deney ve kontrol grupları oluşturulurken Lineer Cebir dersini alan iki sınıf rastgele deney ve kontrol grubu olarak seçilmiştir. İlgili lineer cebir konularına göre hazırlanan TEÇOLİ deney grubuna uygulanmıştır. Kontrol grubuna da geleneksel yöntemle lineer cebir öğretimi yapılmıştır.

Araştırmada kullanılması planlanan Lineer Cebir Başarı Testi'nin pilot uygulamaları deneysel çalışmanın yapılacağı gruptan farklı olması gerektiğinden dolayı Dokuz Eylül Üniversitesi Buca Eğitim Fakültesi İlköğretim Matematik Öğretmenliği bölümünde 3. sınıfta öğrenim görmekte olan lineer cebir dersini almış 170 öğretmen adayları üzerinde gerçekleştirilmiştir.

Veri Toplama Araçları

Lineer Cebir Başarı Testi

Alan yazın taraması sonucunda, “bilgi, kavrama, uygulama, analiz, sentez değerlendirme” basamaklarına uygun şekilde hazırlanan 32 tane taslak madde ilgili alanda uzman öğretim elemanının görüşleri doğrultusunda şekillendirilerek Dokuz Eylül Üniversitesi Buca Eğitim Fakültesi İlköğretim Matematik Öğretmenliği bölümünde 3. sınıfta öğrenim görmekte olan lineer cebir dersini almış öğretmen adayları uygulanmıştır. Finesse programı yardımıyla yapılan analizler sonucunda testin güvenilirlik katsayısı 0,835 olarak bulunmuştur.

Tablo 2. Test Sorularının Ayırt Edicilik İndeksleri

Maddenin ayırt etme indeksi (d)	Madde numarası	Değerlendirme
0,40 ve daha büyük	5,8,13,14,15,16,18,19,20, 22,23,25,28,30,31,32	Oldukça iyi madde
0,30-0,39	4,6,9,10,12,17,21,27,29	İyi madde
0,20-0,29	1,2,11,26	Düzeltilmesi- geliştirilmesi gereken madde
0,19 ve daha küçük	3,7,24	Zayıf madde

Maddelerin güçlükleri ve madde ayırt edicilik indeksleri incelenmiş ve 1,2,3,7,11,24,26. maddelerinin ölçekten çıkarılması uygun görülmüştür. Maddeler çıkarıldıktan sonra Finesse programında analizler tekrar yapılmış ve 25 maddelik ölçeğin güvenilirlik katsayısı 0,849 olarak bulunmuştur.

Tablo 3. Test Sorularının Madde Güçlükleri

Madde güçlüğü (p)	Madde numarası	Değerlendirme
0,80 ve 1 arasındakiler	6,12,16,17,18	Çok kolay madde
0,50 ve 0,80 arasındakiler	4,5,8,9,10,13,14,15,19,20, 21,22,23,25,27,28,30,32	Kolay madde
0,30 ve 0,49 arasındakiler	29,31	Orta güçlükte madde
0,29 ve daha düşükler	-	Zor madde

BULGULAR

Teknoloji destekli çoklu temsil öğretimiyle gerçekleştirilen Lineer Cebir öğretimi ile geleneksel öğretim yöntemleriyle gerçekleştirilen Lineer Cebir öğretimine göre öğrencilerin başarılarında farklılık olup olmadığını belirlemek için öncelikle belirlenen deney ve kontrol gruplarının aralarında homojen olup olmadığı tespit üzere, hazırlanan Lineer Cebir Başarı Testi öğrencilerin önceden görmediği konulardan oluştuğu için, Lineer Cebir dersi ara sınavından aldıkları notlar analiz edilmiştir. Ara sınav notları arasında anlamlı bir farklılık olup olmadığını belirlemek üzere puanların normal dağılım gösterip göstermediği incelenmiştir. Normallik testinde eğer grup büyüklüğü 50'den küçük ise Shapiro-Wilks, 50'den büyük olması durumunda Kolmogorov-Smirnov testi kullanılmalıdır (Büyüköztürk, 2011). Deney ve kontrol gruplarındaki öğrenci sayıları 50 den az olduğu için incelenen Shapiro-Wilks testinin sonuçları Tablo 4' deki gibidir. Tablo 4 deki sonuçlara göre deney ve kontrol gruplarının p değerleri .05 in üzerinde olduğu için grupların ara sınav puanları normal dağılım göstermektedir. Buna göre deney ve kontrol gruplarının ara sınav puanlarına göre aralarında anlamlı bir farkın olup olmadığı parametrik testlerden ilişkisiz örneklem t-testi kullanılmıştır ve sonuçlarına Tablo 4'te yer verilmiştir. Deney ve kontrol gruplarının ara sınav puanları arasında anlamlı bir fark olmadığı Tablo 4'te görülmektedir.

Tablo 4. Ara Sınav Puanlarının Normallik Analizi

	N	\bar{x}	SS	Shapiro-Wilks		sd	t	p
				Statistic	df			
Deney Grubu	35	16.37	10.11	.955	35	.158	71	.048
Kontrol Grubu	38	16.47	7.89	.986	38	.895		

Aralarında homojen oldukları tespit edilen deney ve kontrol gruplarının deneysel işlemler sonrasında LCBT sonuçları karşılaştırılmıştır. Gruplara son test olarak uygulanan LCBT ölçümlerine göre normallik testi sonuçları Tablo 5'te yer almaktadır. Verilere göre deney ve kontrol grupları LCBT ölçümlerine göre normal dağılım göstermemektedir ($p < .05$).

Tablo 5. LCBT Ölçümlerinin Normallik Analizi

	N	\bar{x}	SS	Shapiro-Wilks		
				Statistic	df	Sig.(p)
Deney Grubu	35	23.48	1.42	.882	35	.001
Kontrol Grubu	38	22.00	3.15	.784	38	.000

Bu nedenle grupları karşılaştırmak için parametrik olmayan testlerden Mann Whitney U-testi kullanılmıştır. Elde edilen veriler ise Tablo 6 daki gibidir.

Tablo 6. LCBT Ölçümlerinin Normallik Analizi

	N	Sıra Ortalaması	Sıra Toplamı	U	p
Deney	35	42.76	1496.50	463.500	.024
Kontrol	38	31.70	1204.50		

Sonuçlara göre üç hafta süren teknoloji destekli çoklu temsil temelli lineer cebir öğretimini alan deney grubu öğrencilerin LCBT ölçümleri, geleneksel öğretimle lineer cebir dersini alan öğrencilerin ölçümlerine göre anlamlı derecede farklılık göstermektedir ($U=463.500$, $p < .05$). Sıra ortalamaları incelendiğinde deney grubu öğrencilerinin LCBT sıra ortalaması (42.76) kontrol grubunununkinden (31.70) daha yüksektir. Buna göre teknoloji destekli çoklu temsil temelli lineer cebir öğretimi öğrencilerin lineer cebir başarısını artırıcı özelliktedir.

SONUÇ

Deneysel uygulama sonrasında yapılan analizler sonucunda teknoloji destekli çoklu temsil temelli lineer cebir öğretimini alan deney grubu öğrencilerinin lineer cebir başarılarının geleneksel öğretimle lineer cebir öğretimini alan kontrol grubu öğrencilerine göre anlamlı derecede daha yüksek olduğu görülmüştür. Mevcut teknolojinin olanakları yardımıyla hazırlanan TeÇoLi uygulamasının öğrencilerin lineer cebirdeki başarılarını artırıcı özelliklere sahip olduğu söylenebilir. Bu sonucun elde edilmesinde, TeÇoLi'nin temsiller arası geçişlere imkân verecek nitelikte olması, uygulamada kullanılan çoklu temsillerin uygun seçimi ve doğru sırayla öğrencilere sunulması, temsillerin teknolojik olanaklarla birlikte daha ileri seviyelere taşınarak öğrencilerin derse olan ilgilerini artırması gibi faktörlerin rol oynadığı söylenebilir. Ayrıca konu anlatımının araştırmacı tarafından seslendirilerek bilgisayar ortamında video formatında kayıt edilerek öğrencilere internet üzerinden kullanıma açılması, öğrencilerin konu anlatım videolarını istedikleri zaman istedikleri bölümleri izleme imkânı sunmuştur. TeÇoLi sürecinde araştırmacı tarafından hazırlanan ders kaynaklarının internet üzerinden erişime açılmasıyla öğrenciler bunları istekleri zaman ve yerde inceleyerek uzaktan eğitimle gerçekleştirilen derse hazırlıklı olarak gelerek, önceden kayıt ettikleri anlaşılmayan noktaları sorma imkânı bulmuşlardır. Böylece zaman ve mekândan tasarruf sağlanmıştır. Bu sonuçlar Fraser (2010), Özel, Capraro ve Yetkiner (2008), Akkuş Çıkla (2004), Konyalıoğlu ve diğ. (2011) gibi araştırmacıların yaptıkları çalışmalarla paraleldir.

TeÇoLi'nin uzaktan eğitim kısmında, öğrencilerin videoyu izlerken takıldıkları noktalarda anında uzman desteği alamaması, videolarda anlaşılmayan noktalardan bazılarını not etmeyi unutmaları, bazen internete erişim sorunlarının yaşanması, uzaktan eğitimle gerçekleştirilen derste kullanılan sohbet odasında sorulan dersle ilgili noktaların herkes tarafından anlaşılama gibi sorunlar yaşanmıştır.

ÖNERİLER

TeÇoLi öğrencilerin lineer cebir başarısını artırıcı özelliklere sahip olduğu sonucu elde edilmiştir. Bu yöntem lineer cebir dersi veren öğretim elemanlarına ve araştırmacılara örnek bir uygulama olabilir. Araştırmada uzaktan eğitim sürecinde yaşanan sorunları engelleyici yönde çalışmalar yapılabilir.

TeÇoLi'de kullanılan çoklu temsillerin çeşitlendirilip öğretime doğru bir şekilde entegrasyonunun sağlanmasıyla lineer cebir başarısını daha ileri düzeyde artırıcı seviyeye taşınabilir. Bu konu ileri araştırmaların amacı olabilir. Bu araştırmada kullanılan teknoloji destekli çoklu temsil temelli öğretimin diğer matematik alan derslerinde kullanımına ilişkin çalışmalar gerçekleştirilebilir.

Teşekkür: Bu çalışmamızın uzaktan eğitim sistemi desteğini sağlayan Prof. Dr. Vahap TECİM ve Uzm. Emre KARAGÖZ başta olmak üzere Dokuz Eylül Üniversitesi Uzaktan Eğitim Uygulama ve Araştırma Merkezi'ne (DEUZEM) teşekkürlerimizi sunarız.

NOT: Bu çalışma, 2013.KB.EĞT.007 nolu proje kapsamında Dokuz Eylül Üniversitesi Bilimsel Araştırma Projeleri Koordinasyon Birimi tarafından desteklenen, ikinci yazar danışmanlığında, birinci yazar tarafından hazırlanan “Teknoloji Destekli Çoklu Temsil Temelli Öğretimin Öğrencilerin Lineer Cebir Öğrenimine ve Matematiğe Yönelik Tutumlarına Etkisi” isimli yüksek lisans çalışmasının bir bölümünü oluşturmaktadır.

KAYNAKLAR

- Akkuş Çıkla, O. (2004). The effects of multiple representations-based instruction on seventh grade students' algebra performance, attitude toward mathematics, and representation preference. Unpublished Ph. D. dissertation, The Graduate School of Natural and Applied Sciences of Middle East Technical University, Ankara.
- Delice, A. ve Sevimli, E. (2010). Öğretmen adaylarının çoklu temsil kullanma becerilerinin problem çözme başarıları yönüyle incelenmesi: belirli integral örneği. *Kuram ve Uygulamada Eğitim Bilimleri*, 10(1), 111-149.
- Durkaya M., Şenel, E. Ö., Öçal, M. F., Kaplan A., Aksu Z. ve Konyahoğlu, A. C. (2011). Pre-service mathematics teachers' multiple representation competencies about determinant concept. *Procedia Social and Behavioral Sciences*, 15, 2554–2558.
- Fraser, V. A. (2010). The use of technology-generated representations in mathematics instruction: a study of novice teachers' practices. Unpublished Ph. D. dissertation, University of Virginia.
- Konyahoğlu, A.C., Işık, A., Kaplan A., Hızarcı, S., & Durkaya, M. (2011). Visualization approach in teaching process of linear algebra. *Procedia Social and Behavioral Sciences*, 15, 4040–4044.
- Mallet, D. G. (2007). Multiple representations for systems of linear equations via the computer algebra system maple. *International Electronic Journal of Mathematics Education*, 2(1), 16-32.
- Neria, D., Amit, M. (2004). Students preference of non-algebraic representations in mathematical communication. Proceedings of the 28th Conference of the International Group for the Psychology of Mathematics Education, 3, 409-416.
- Özel, S., Capraro, R. M., & Yetkiner, Z. E. (2008). A technology intervention using multiple representations on mathematics. Proceedings of the 11th meeting of the International Congress on Mathematical Education. Monterrey, Mexico.
- Sert, Ö. (2007). Eighth grade students' skills in translating among different representations of algebraic concepts. Unpublished master's thesis, Middle East Technical University.
- Wong, W.K., Yin, S.K., Yang, H.H., & Cheng, Y.H. (2011). Using computer-assisted multiple representations in learning geometry proofs. *Educational Technology & Society*, 14(3), 43–54.

ORTAOKUL 4. SINIF ÖĞRENCİLERİNİN EŞİTSİZLİK KONUSUNDAKİ SOYUTLAMA SÜREÇLERİNİN RBC MODELİ BAĞLAMINDA İNCELENMESİ

THE INVESTIGATE TERMS OF RBC MODEL OF THE 4th GRADE MIDDLE SCHOOL STUDENTS' ABSTRACTION PROCESSES ON INEQUALITY TOPIC

Elif AÇIL

Milli Eğitim Bakanlığı, Osman Gazi Ortaokulu, Erzurum
elifacil@hotmail.com

Abdullah KAPLAN

Atatürk Üniversitesi Kazım Karabekir Eğitim Fakültesi İlköğretim Bölümü Matematik Eğitimi ABD
kaplan5866@hotmail.com

ÖZET: Bu araştırma ile ortaokul 4. sınıf öğrencilerinin, bilgiyi oluşturma süreçlerinin ve önceden yapılandırılmış matematiksel bilgiyi tekrar organize edebilme düzeylerinin incelenmesi amaçlanmıştır. Araştırmanın örneklemini, başarı durumları yüksek, orta ve düşük olan 3 ortaokul 4. sınıf öğrencisi oluşturmaktadır. Araştırma nitel araştırma yöntemlerinden durum çalışması özelliğindedir. Araştırmaya veri sağlayan araçlar ise, öğrencileri düşündürmeye teşvik eden matematik problemlerinin yer aldığı çalışma kağıtları, görüşme kayıtları ve gözlem notlarıdır. Veriler içerik analizi ile incelenmiştir. Elde edilen veriler, matematik başarısı ne olursa olsun öğrencilerin tanıyabildikleri verileri kullanabildiğini ve yeni bilgileri, eski bilgileri kullanabildikleri ölçüde oluşturabildiğini göstermektedir. Aslında basit görüldüğü için pek üzerinde durulmayan, ön bilgilerin hatırlanması yani 'tanıma eylemi', matematiksel soyutlamanın temel basamağıdır ve matematiksel soyutlama için bu eylemin eksiksiz bir şekilde tamamlanması gerekmektedir. Araştırmanın bulguları bu ifadeyi destekler niteliktedir. Ayrıca, araştırmadan elde edilen verilere göre, dışarıdan verilen desteğin, öğrencilerin soyutlama sürecine olumlu anlamda katkı sağladığı sonucuna ulaşılmıştır.

Anahtar sözcükler: Matematiksel Düşünme, Soyutlama Süreci, RBC Modeli

ABSTRACT: The purpose of the study was to investigate of mathematical knowledge construct processes and reorganizing level previous mathematical knowledge of 4th grade middle school students. This study was of three middle school students who had different mathematical success. The study was qualitative research and case study was the research method. We used study papers, interview records and observation notes as data collection tools. The study papers was of three mathematical problems which encouraging to think. The analyzing of the datas was used content analyze method. It was observed that students used the knowledge to the extent that recognizing and constructed to the extent that building. 'Recognizing' action was seen simple and so, this action didn't care about. In fact, the action was basic step of mathematical abstraction and it needed to completely apply for mathematical abstraction. Finding of study was support to referred to above. Also, according to datas obtained from study , it was seen that given the support from outside contribute positively to students' abstraction processes.

Key words: Mathematical Thinking, Abstraction Process, RBC Model

GİRİŞ

Düşünmeyi geliştirdiği bilinen en önemli araçlardan biri matematiktir. İnsanı diğer canlılardan ayıran en temel özellik şüphesiz insanın düşünebilme yetisine sahip olmasıdır. Bu nedenledir ki matematik eğitimi temel eğitimin ilk basamağını oluşturmaktadır. Dolayısıyla temel eğitim için matematik eğitimi keyfi bir gereksinim olmaktan çok daha öteye gitmektedir. Matematiksel düşünme, tahmin edebilme, tümevarım, tümdengelim, betimleme, genelleme, soyutlama, örnekleme, ispatlama gibi karmaşık süreçlerin birleşimi olarak tanımlanmaktadır (LiuPo-Hung, 2003; akt. Alkan & Bukova Güzel, 2005). Matematiksel düşünme süreçlerinden biri de soyutlamadır. Soyutlama çok yönlü karmaşık bir kavramdır. Literatürde bu kavram ile ilgili farklı açılardan yapılan tanımlamalara rastlamak mümkündür. Soyutlama kavramı üzerine hem fikir olunan bir tanım

bulunmasa da, soyutlama ile ilgili fikir birliğine varılan tek nokta bu kavramın bireye kendini değişik açılardan inceleme olanağı sunmasıdır. Soyutlama, önceden yapılan matematiğin yeni matematiksel yapı içerisinde dikey olarak tekrar organize edilmesinin etkinliği olarak tanımlanmaktadır (Hershkowitz, Schwarz & Dreyfus, 2001).

Soyutlama bir süreçtir ve bu sürece farklı bakış açıları ile yaklaşan araştırmacılar vardır: bilişsel soyutlama ve sosyo-kültürel soyutlama (Yeşildere & Türnüklü, 2008). Bilişsel açıdan bakıldığında soyutlama, deneysel, sözde-deneysel ve yansıtıcı olmak üzere üç boyutta ele alınmaktadır. Sosyo-kültürel açıdan bakıldığında ise soyutlama, gözlenebilmeye imkan tanıyan boyutlardan oluşmaktadır. Recognising-Building with-Constructing (RBC) modeli etkinlik teoremine dayalı bir sosyo-kültürel soyutlama modelidir. Herskowitz vd. (2001) tarafından ilk olarak ortaya atılan bu modelin amacı, soyutlama süreci hakkında bilgi edinmektir. Modelde yer alan üç bileşen, gözle görülebilir deliller sunacağından soyutlama sürecine ışık tutacaktır. RBC modeli, bağlamsal parametrelere karşı oldukça duyarlıdır ve sosyal etkileşim ve derin düşünceli anlamlar vasıtasıyla soyutlama süreci boyunca gelişimi öne sürer. Matematik eğitiminde bir model ya da teori; tahmini destekleyebilir, güçlü açıklamaya sahip olabilir, bireyin karmaşık ve karşılıklı ilişkili fenomeni hakkındaki düşüncesini organize etmeye yardımcı olabilir, veri analizi olarak hizmet edebilir ve yüzeysel tanımların ötesine giden öğrenme hakkındaki fikirlerin iletişimi için bir dil sağlayabilir (Dubinsky & McDonald, 2001). İlgili literatür ile yapılan çalışmalar söz konusu modelin soyutlama sürecine pozitif yönde etki ettiğini göstermektedir (Biederman, 1987; Herskowitz vd., 2001; Dreyfus & Tsamir, 2004; Özmantar & Monaghan, 2007; Yeşildere & Türnüklü, 2008; Altun & Yılmaz, 2008).

Yeşildere & Türnüklü (2008) çalışmalarında farklı matematiksel güce sahip öğrencilerin bilgi oluşturma süreçlerini RBC modeli çerçevesinde incelemişlerdir. Elde edilen veriler, matematiksel güç farklılığının bilgi oluşturma süreçlerinde takip edilen yolları farklılaştırdığı yönündedir. Diğer yandan Özmantar & Roper (2004) çalışmalarında öğrencilerin soyutlama süreçlerinde tutorun rolünü araştırmışlardır. Araştırma verileri RBC modeli ile değerlendirmeye alınmıştır. Sonuç olarak, tutor desteğinin soyutlamaya önemli ölçüde katkı sağladığı belirtilmiştir.

Bu araştırma ile ortaokul 4. sınıf öğrencilerinin, bilgiyi oluşturma süreçlerinin incelenmesi ve önceden yapılandırılmış matematiksel bilgiyi tekrar organize edebilme düzeylerinin incelenmesi amaçlanmıştır. Araştırmanın amacına hizmet etmesi için, ortaokul 4. sınıf seviyesindeki 'Birinci dereceden iki bilinmeyenli doğrusal eşitsizlikler' konusu araştırma konusu olarak seçilmiştir. Araştırmanın amacı doğrultusunda cevap aranacak araştırma soruları şu şekildedir:

1. Öğrenciler matematiksel bilgiyi oluştururken hangi yolları izliyorlar?
2. Öğrencilerin önceki bilgilerini tekrar organize edip kullanma düzeyleri nelerdir?

YÖNTEM

Araştırma Deseni

Bu araştırma bir durum çalışmasıdır, dolayısıyla nitel bir araştırmadır. Nitel araştırma, araştırılacak konunun doğal ortamında anlaşılmasına ve yorumlanıp sonuç çıkarılmasına imkân veren bir araştırma yöntemidir (Denzin & Lincoln, 2000, s. 215). Durum çalışması nitel araştırma desenlerinden biridir. Durum çalışması, bir ya da birkaç olguyu kendi yaşam çerçevesinde açıklamaya çalışan bir araştırma desendir (Yin, 1984, s. 23, akt. Yıldırım & Şimşek, 2011, s. 280). Durum çalışmaları süreç odaklıdır ve 'Neden?' ve 'Nasıl?' soruları ile ilgilenir. Bu açıdan bakıldığında durum çalışmasının, öğrencilerin matematiksel bilgilerini nasıl oluşturduklarının incelenmesi amacına hizmet edecek bir araştırma deseni olduğu düşünülmüştür.

Çalışma Grubu

Bu araştırmanın çalışma grubunu, 2013-2014 öğretim yılında Erzurum il merkezinde bulunan bir devlet okuluna halen devam etmekte olan ortaokul 4. sınıf öğrencileri oluşturmaktadır. Bu öğrenciler arasında matematiksel başarıları düşük, orta ve yüksek olan 3 öğrenci, amaçlı örnekleme yöntemlerinden aykırı durum örnekleme yöntemi kullanılarak seçilmiştir. Öğrencilerin seçiminde gönüllülük esas olup, herhangi bir ön test ya da ölçek kullanılmamıştır. Öğrencilerin belirlenmesi hususunda yardımcı olması adına, öğrencilerin öğretmenleri ile görüşülmüş, öğrencilerin okul başarı puanları ve deneme sınav sonuçları incelenmiştir. Ayrıca, öğrencilerle yapılacak uygulama öncesinde, hem okul idaresinden hem de öğrencilerden gerekli izinler alınmıştır. Öğrencilere, uygulanan çalışma kağıtlarının inceleneceği, sonrasında görüşme yapılacağı ve bu görüşmelerin kayıt altına alınacağı önceden bildirilmiştir. Yapılan bu çalışmanın başarı notu ile herhangi bir ilgisi olmadığı da açıklanarak, öğrencide oluşacak kaygıların önüne geçilmesi hedeflenmiştir.

Veri Toplama Araçları

Çalışma Kağıtları

Araştırmaya veri sağlayan çalışma kağıtları, 'Birinci dereceden iki bilinmeyenli doğrusal eşitsizlikler' konusu ile ilgili matematiksel problemlerden oluşmaktadır. Söz konusu konu ile ilgili 3 problem, Milli Eğitim Bakanlığı Öğretmen Kılavuz Kitabı (2011) referans alınarak, araştırmacı tarafından oluşturulmuştur. Problemlerin oluşturulmasında, öğrencilere önceki bilgilerini olabildiğince kullanma olanağı sunmasına ve öğrencilerin soyutlama yapabilmelerine olanak tanıyan özellikte olmasına dikkat edilmiştir. Ayrıca problemlerin oluşturulması esnasında uzman görüşüne başvurulmuş ve problemlerin dil bakımından incelenmesi sağlanmıştır. Hazırlanan problemler bir üst sınıfta öğrenim gören 8 öğrenciye uygulanmıştır. Bu pilot çalışmadan sonra gerekli düzenlemeler yapılarak ve tekrar uzman görüşüne başvurularak problem cümlelerine son hali verilmiştir. Böylelikle bu araştırmaya veri sağlayacak araçların geçerlilik ve güvenilirlik çalışmaları tamamlanmıştır.

Veri Toplama Süreci

Bu araştırmada nitel veri toplama yöntemlerinden gözlem ve görüşme bir arada kullanılmıştır. Bu iki yöntemin bir arada kullanılması ile oluşabilecek hataların en aza indirilmesi amaçlanmıştır. Araştırmaya veri sağlayan çalışma kağıtları üç matematik probleminden oluşmaktadır. Her bir problem ayrı ayrı kağıtlara yazılmış ve bu problemler öğrencilere belli bir sıra ile uygulanmıştır. Problemlerin uygulanma sırası RBC modeline uygun olarak yapılmıştır. Araştırmacı uygulama sırasında gözlemci olarak ortamda bulunmuş, bunun haricinde hiçbir müdahalede bulunmamış, elde ettikleri gözlemlerini not etmiştir. Tüm uygulama bittikten sonra öğrencilerle bire bir görüşülmüştür. Görüşme için ayrı bir form kullanılmamış, sadece öğrencilerin çalışma kağıtlarından yararlanılmıştır. Fakat görüşme esnasında öğrencilerin karaladıkları kağıtlara dokunulmamış, bunun için tekrar ayrı bir kağıt kullanılmıştır. Görüşmelerde öğrencilerin anlaşılmayan ifadeleri üzerinde durulmuştur. Öğrencilere herhangi bir yanlı yönlendirme yapılmamış, sadece gerekli görüldüğü zaman ipuçları verilmiştir. Öğrencilerin görüşmeden önceki ve sonraki cevapları karşılaştırılmak üzere değerlendirmeye alınmıştır. Yapılan görüşmeler araştırmacı tarafından kayıt altına alınmıştır. Hem öğrencilere uygulanan çalışma kağıtları hem de sonrasında yapılan görüşmelerin kayıtları gözlem notları ile birlikte araştırmaya veri sağlayan dokümanlar olarak kullanılmıştır.

Veri Analizi

Araştırma verileri nitel özellik taşıdığından, veriler nitel veri analizi türlerinden içerik analizi ile incelenmiştir. İçerik analizi, verileri tanımlamaya ve verilerin içinde gizli olabilecek gerçekleri ortaya çıkarmaya çalışan bir nitel veri analiz yöntemidir (Yıldırım & Şimşek, 2011, s. 227). Öğrencilerin problemlere verdiği cevaplar analiz edilmiş ve öğrencilerin ifadeleri arasındaki örüntüler incelenmiştir. Gerekli kodlamalar yapılarak incelenen bu örüntüler, genel olarak RBC modeli çatısı altında değerlendirmeye alınmıştır. Dolayısıyla, tanıma, kullanma ve oluşturma kategorileri altında, öğrenci cevapları analiz edilmiş ve fark edilen önemli durumlar yorumlanmıştır.

BULGULAR

Ortaokul 4. sınıf öğrencileri ile yürütülen bu çalışmada her bir öğrenciye kod isim verilmiştir. Matematiksel başarısı yüksek olan öğrenci Nermin'in (N), orta olan Serpil'in (S), düşük olan Eda'nın (E) cevapları incelenmiş ve ifadelerin dikkat çeken noktaları, önceden belirlenmiş kategoriler (tanıma, kullanma, oluşturma) altında, aşağıdaki tabloda sunulmuştur. Araştırmada yer alan üç soru her ne kadar aynı amaca hizmet etse de özele inildiğinde, ilk soru öğrencinin daha çok tanıma, ikinci soru kullanma ve son soru tüm bunlarla birlikte oluşturma eylemini harekete geçirici özelliktedir. Bu kanılara varmak için, sadece öğrencilerin vermiş olduğu cevapları incelemek yeterli değildir. Görüşmelerde yapılan yansız yönlendirmelerle bu eylemlerin ortaya çıkarılması hedeflenmiştir. Bu kısımda soruların verilmesi aşağıdaki tabloyu incelemede kolaylık sağlayacaktır.

1. Ayça'nın yaşının 3 katının 4 eksiği 32'den büyüktür. Buna göre Ayça **en az** kaç yaşındadır?
2. İki sayıdan birinin 2 katının 3 fazlası, diğerinin 3 katının 3 eksiğinden küçüktür. Bu sayıların koordinat düzleminde bulunacağı bölgeyi gösteriniz.
3. $x - y \geq -3$ ve $6x + 3y \leq 18$ eşitsizlikleri ile x eksenini arasında kalan bölgenin alanını bulunuz.

Tablo 8: Öğrenci Cevaplarının RBC Modeli Örnekleri

Tanıma	Kullanma	Oluşturma
--------	----------	-----------

A: Öncelikle soruyu sesli bir şekilde okuyalım.	S, soruyu sesli okuduktan sonra hemen çözmeye geçer.	N: (Soruyu seslice okur) Öncelikle grafik çizmeliyim.
E: (Okur) Ayça'nın yaşına x diyelim. (denklemi oluşturur ve eşit olarak düşünür)	S: Öncelikle ilk sayıya x, ikincisine y derim.	A: Bizden istenen ne?
A: Peki eşit mi sence?	A: Evet. (Denklemi alt alta yazar ve toplar.) Neden topladım?	N: Alan. Muhtemelen bir çokgen.
E: Hayır, büyük, yanlış yazdım. (yazdığını değiştirmiyor)	S: Çünkü x ve y'yi koordinat düzleminde bulmak için.	A: Grafikleri neden ayrı koordinatlarda çiziyorsun?
A: O zaman ne yapmalıyız?	A: Peki böyle x ve y'yi nasıl bulursun.	N: Kafam karışır, sonradan birleştirsem. Şekil daha iyi çıkar gibi.
E: Aslında, eşit gibi düşünüp işlem yapsam, sonrada soruya tekrar dönerim. Ayça'nın yaşı 12'den büyük olmalı, o zaman 11' dir.	S: +3 ile -3 birbirini götürür. 2x ve 3y kalır. O halde x,2; y'de 3'tür. (Koordinat düzlemi çizer ve I. bölgede olduğunu gösterir.	A: Evet. Ben dinliyorum seni.
A: Peki üsteki eşitsizliği sağlıyor mu?	A: Bu şekilde olduğuna emin misin?	N: şimdi kesişim noktalarını bulalım. Evet $y=4$ noktasında kesişiyor sanırım.
E: Hayır, sanırım ters yaptım. 13 olmalı, en az 13.	S: Aslında değilim, saçma oldu sanki.	A: Evet. (Aynı düzleme alıyor grafikleri)
	A: O zaman soruyu tekrar gözden geçir.	N: Zaten üç sınırı varsa şekil üçgendir.
	S: (Tekrar okur). Aynı sanki.	A: Evet. (Şekli tarayıp, üçgenin yüksekliğinin y olduğunu söylüyor)
	A: Taraf tarafa toplamanı gerektirecek şey ne?	N: Alanı hesaplıyor ve buluyor.
	S: I. Evet ya yok. Küçük yazacam araya, pardon.	A: Peki başka türlü bulunabilir miydi bu alan.
	A: Devam edelim. (Eşitsizliği yazar, x ve y'nin değerini bulur.	N: Bilmiyorum.
	S: Sanırım sadece bölgeyi yanlış gösterdim, II. bölgeymiş.	A: (y eksenini işaret ederek) Yükseklikle bağlantı kurulabilir mi?
	A: Peki bulduğun x ve y değerleri hakkında ne söyleyebilirsin.	N: Benzerlik gibi mi?
	S: Zaten orası kafamı karıştırdı, $x < -3$, -3 değilki.	A: Olabilir mi?
	A: o halde iyi düşün, sadece bir nokta mı belirtir?	N: (Düşünüyor) Evet, benzerlikten çözebiliriz (çözüyor)
	S: (sessizlik) Grafik mi çizmeliyim yoksa.	A: Peki x eksenini değil de y eksenini deseydi?
	A: Deneyebilirsiniz.	N: Bakayım, şekil değişiyor. Hatta o zaman yükseklikte x oluyor. Az önce y idi.
	S: (Grafığı çizer) Evet, evet, böyle olmalı. Hatırladım gibi, yukarıyı da tarayacak. Taralı bölgede olacak.	A: Sence bu söylediklerin arasında bir bağ var mıdır?
		N: (Şekil üzerinde düşünerek tekrarlıyor). Aslında var gibi ama emin değilim.
		A: Emin olmadığım şey ne?
		N: Üçgenin tabanlarını diyecektim.
		A: Evet söyle, dinliyorum.
		N: Üçgenin tabanı x ekseninde mesela. O zaman yükseklik y noktası oluyor. Tam tersi de mümkün.

(A): Araştırmacı

SONUÇ

Matematik eğitiminde bir model ya da teori; tahmini destekleyebilir, güçlü açıklamaya sahip olabilir, bireyin karmaşık ve karşılıklı ilişkili fenomeni hakkındaki düşüncesini organize etmeye yardımcı olabilir, veri analizi olarak hizmet edebilir ve yüzeysel tanımların ötesine giden öğrenme hakkındaki fikirlerin iletişimi için bir dil sağlayabilir (Dubinsky & McDonald, 2001). Bu çalışmada soyutlamaya dayalı bir model olan RBC modeli kullanılmıştır. Bu model tanıma, kullanma ve oluşturma eylemlerinden oluşmaktadır.

Araştırmanın bulguları gösteriyor ki, bu üç eylem birbirinden bağımsız değildir. Başarı düzeyi ne olursa olsun, bir öğrenci hatırlamadığı bilgileri kullanamamakta ve böylelikle yeni bilgiler oluşturmakta zorluk çekmektedir.

Bu döngünün sürekliliği, başarısızlığı getirmekte ve aşılması zor güçlükler neden olabilmektedir. Aslında basit görüldüğü için pek üzerinde durulmayan, ön bilgilerin hatırlanması yani 'tanıma eylemi' matematiksel soyutlamanın temel basamağıdır ve matematiksel soyutlama için bu eylemin eksiksiz bir şekilde tamamlanması gerekmektedir. Bu eylem basit bir hareket değildir, öğrencilerin yeni bilgi ile karşılaştığında eski bilgilerini nasıl kullanması gerektiğine yön veren bir eylemdir.

Tanımaya eylemini (görüşmeden önce) gerçekleştiremeyen E, kendisine verilen ipuçlarını bile kullanamamaktadır ve karşılaştığı yeni durumlarda pasif kalmıştır. Diğer yandan S, tanıma eylemini gerçekleştirdiğinden, önceki bilgilerini yeni durumlara uyarlayabilmektedir. Fakat S'nin oluşturma eylemini kendi başına gerçekleştiremediği görülmüştür. O halde bilgileri hatırlayıp kullanmanın, oluşturma eylemi için gerek olduğunu ama yeterli olmadığını söyleyebiliriz. Ayrıca veriler, başarı düzeyleri farklı öğrencilerin önceki bilgilerini organize edip kullanma düzeylerinin de birbirinden farklı olduğunu göstermektedir.

Yapılan görüşmeler sonucunda elde edilen veriler ile öğrencilerin sorulara müdahalesiz cevapları karşılaştırılmıştır. Yapılan küçük uyarıların oluşturduğu fark görmezden gelinmeyecek kadar önemlidir. İlk başta kullanma oluşturma eylemini gerçekleştiremeyen N, yapılan küçük uyarılar ve ipuçları ile bu düzeyde davranış sergileyebilmiş ve soyutlama yapabilmektedir. Literatürde soyutlama yeteneğinin geliştirilmesinde alınan yardımın önemliliği üzerine yapılan araştırmalar yeterli sayıda olmasa da mevcuttur (Dreyfus & Tsamir, 2004; Ozmantar & Roper, 2004; Yeşildere & Türnüklü, 2008).

Öğrencilerin kavrayarak anlamlarını sağlamak, olası güçlükleri kendi başlarına aşmalarına yardım etmek ve matematiksel başarının artık zaruri bir ihtiyaç olduğu fikrini benimsetmek için soyutlama süreçlerinin incelenmesine dair daha kapsamlı çalışmalar yapılabilir.

KAYNAKLAR

- Alkan, H., Bukova G., E., (2005). Öğretmen Adaylarında Matematiksel Düşünmenin Gelişimi, *Gazi Eğitim Fakültesi Dergisi*, 25 (3), 221-236.
- Altun, M. & Yılmaz, A. (2008). Lise öğrencilerinin tam değer fonksiyonu bilgisini oluşturma süreci. *Ankara Üniversitesi Eğitim Bilimleri Fakültesi Dergisi*, 41(2), 237-271.
- Biederman, I. (1987). Recognition-by-Components: A Theory of Human Image Understanding, *Psychological Review*, 94 (2), 115-147.
- Denzin, K. & Lincoln S. (2000). *The Sage Handbook of Qualitative Research*. Third edition, SAGE.
- Dreyfus, T. and Tsamir, P.: 2004, 'Ben's consolidation of knowledge structures about infinite sets', *Journal of Mathematical Behavior*, 23, 271-300.
- Dubinsky, E., McDonald, M. (2001). APOS: A Constructivist Theory of Learning in Undergraduate Mathematics Education Research. In D. Hilton et.(Eds.) *The teaching and learning of mathematics at University level: An ICMI Study*, Kluwer Academic Publishers, 273-280.
- Dubinsky, E., and McDonald, M. A. (2001). *APOS: A Constructivist Theory of Learning in Undergraduate Mathematics Education Research*. In D. Holton (Ed.)
- Hershkowitz, R., Schwarz, B.B., & Dreyfus, T. (2001). Abstraction in Context: Epistemic Actions. *Journal for Research in Mathematics Education*, 32(2): 195- 222.
- Liu P. H. (1996). *Do teachers need to incorporate the history of mathematics in their teaching?*, *The Mathematics Teacher*. Reston: Sep. Vol.96, Iss. 6; pg. 416.
- MEB (2011). *Matematik Öğretmen Kılavuz Kitabı*. Can Matematik Yayınları.
- Ozmantar, M. & Roper, T. (2004). Mathematical Abstraction Through Scaffolding. *PME* 28, 3, 481-488.
- Ozmantar, M. & Monaghan, J. (2007). A Dialectical Approach to the Formation of Mathematical Abstraction. *Mathematics Education Research Journal*, 19 (2), 89-112.
- Yeşildere, S. & Türnüklü, E. (2008). An Investigation of the Components Affecting Knowledge Construction Processes of Students with Differing Mathematical Power. *Eurasian Journal of Educational Research*, 31, 151-169.
- Yıldırım, A. ve Şimşek, H. (2011). *Nitel Araştırma Yöntemleri*, Ankara: SeçkinYayıncılık.

STUDENTS PERCEPTIONS ABOUT EFFECTS OF TEACHERS' CHARACTERISTICS ON STUDENTS MATH ACHIEVEMENT

Nurhayat GÜREL

Mermet Akif Ersoy Üniversitesi, Eğitim Bilimleri Enstitüsü, Sınıf Öğretmenliği Programı
gurelnurhayat@gmail.com

Ramazan GÜREL

Mermet Akif Ersoy Üniversitesi, Eğitim Fakültesi, İlköğretim Bölümü
rgurel@mehmetakif.edu.tr

ABSTRACT: The purpose of this study is to investigate students' perceptions of the common and differing effective characteristics of teachers on students' mathematics achievement and to explore whether the effects of these characteristics were significantly associated with certain variables (gender, grade level, mathematics achievement and mother and father education level). Relational survey method was used. Participants of the study was selected randomly and consisted of 320 students from 5th through 8th grades. Data were collected by "Mathematics Teacher Characteristics Scale". The data were analyzed for descriptive statistics, t-test and ANOVA. According to findings, the most effective characteristics were about teachers' subject matter and pedagogical knowledge. Furthermore, students' gender, math achievement and grade level were important variables correlated with the teachers' characteristics. Female students declared more than male students that teachers characteristics affecting students' achievement. 5th grades declared more than 6th, 7th and 8th grades. It was found that, there was no statistically significant main effect for mother and father education level. You need to insert an English abstract into this section by taking into account exactly the same format.

Key words: Students, Mathematics Teacher, Effective Characteristics

HAZIRLIK SINIFI ÖĞRENCİLERİNİN YABANCI DİL DERSLERİNDE BİLGİ VE İLETİŞİM TEKNOLOJİLERİ KULLANILMASINA YÖNELİK TUTUMLARI

LEARNER ATTITUDES TOWARD THE USE OF INFORMATION AND COMMUNICATION TECHNOLOGIES IN FOREIGN LANGUAGE CLASSES

Mehmet KOÇYİĞİT
Afyon Kocatepe Üniversitesi
mkocyyigit@aku.edu.tr

Cahit ERDEM
Afyon Kocatepe Üniversitesi
cerdem@aku.edu.tr

Abdullah SAYKILI
Afyon Kocatepe Üniversitesi
asaykili@aku.edu.tr

ÖZET: Bu araştırmada üniversite kademesinde İngilizce hazırlık sınıflarında öğrenim gören öğrencilerin yabancı dil derslerinde bilgi ve iletişim teknolojileri kullanılmasına yönelik tutumlarının belirlenmesi ve Saykılı ve diğ. (2013) tarafından geliştirilen BİT tutum ölçeğinin farklı bir örneklem grubunda uygulanarak faktör yapısının geçerliğinin sınanması hedeflenmiştir. Araştırma nicel, betimsel bir tarama araştırmasıdır. Araştırmanın evrenini Türkiye'nin batısında bir devlet üniversitesinin hazırlık sınıfında 2013-2014 akademik yılında öğrenim görmekte olan 623 öğrenci oluşturmaktadır. Araştırmada amaçlı örnekleme tekniği kullanılarak 353 gönüllü öğrenci örnekleme alınmıştır. Elde edilen veriler üzerinde ilk olarak ölçeğin faktör yapısını sınamak amacıyla doğrulayıcı faktör analizi yapılmıştır. Sonraki aşamada veriler üzerinde gerekli istatistiki işlemler yapılarak öğrencilerin tutumları belirlenmiş ve farklı demografik değişkenlere göre incelenmiştir.

Anahtar sözcükler: Bilgi ve İletişim Teknolojileri, Hazırlık sınıfları, Tutum Ölçeği, Yabancı Dil Eğitimi

ABSTRACT: This study aims to investigate learner attitudes toward the use of information and communication technologies (ICT) in foreign language classes at tertiary level testing the validity of factor structure of ICT scale developed by Saykili et al. (2013). A distinct sample of 353 volunteering participants studying English as a foreign language at a preparatory school of a western public university in Turkey in the academic year of 2013-2014 took part in the study. The study follows a quantitative descriptive survey research design. Confirmatory factor analysis was carried out on the data to test the validity of factor structure of the scale. Next, learner attitudes were investigated depending on various demographic variables using the required statistical processes.

Keywords: Information and Communication Technologies (ICT), Foreign Language Preparatory Schools, Attitude Scale, Foreign Language Education

ARAŞTIRMAYA DAYALI FEN LABORATUARI UYGULAMALARININ ÖĞRETMEN ADAYLARININ YARATICI DÜŞÜNME DÜZEYLERİNE ETKİSİ

THE EFFECT OF INQUIRY BASED SCIENCE LABORATORY ACTIVITIES ON PRESERVICE SCIENCE AND TECHNOLOGY TEACHERS' CREATIVE THINKING LEVELS

Hatice BAYKARA

Pamukkale Üniversitesi Eğitim Bilimleri Enstitüsü İlköğretim A.B.D.
hbaykara@pau.edu.tr

Yrd. Doç. Dr. Zeha YAKAR

Pamukkale Üniversitesi Eğitim Bilimleri Enstitüsü İlköğretim A.B.D.
zyakar@pau.edu.tr

ÖZET: Bu çalışmada Fen Laboratuvar Uygulaması dersinde uygulanan araştırmaya dayalı öğrenme uygulamalarının öğretmen adaylarının yaratıcı düşünme düzeylerine etkisi araştırılmıştır. Araştırmanın örneklemini Pamukkale Üniversitesi Eğitim Fakültesi ilköğretim fen bilgisi öğretmenliğinde okuyan 36 öğretmen adayı oluşturmuştur. Bu araştırmada veriler Torrance Yaratıcı Düşünme Testi (TYDT) ile toplanmıştır. Araştırmaya dayalı laboratuvar uygulamaları ile öğretmen adaylarının yaratıcı düşünme düzeylerindeki gelişim TYDT’de yer alan akıcılık, esneklik ve özgünlük düzeylerinde incelenmiştir. Veriler, SPSS 13 paket programı ile amaca uygun olarak aritmetik ortalama, standart sapma ve T testi değerlerine göre analiz edilmiştir. Verilerin analizi sonucunda öğretmen adaylarına uygulanan araştırmaya dayalı laboratuvar uygulamalarının yaratıcı düşüncelerini geliştirmede etkili olduğu görülmüştür. Ayrıca bu çalışmanın sonuçlarına göre öğretmen adaylarının araştırmaya dayalı laboratuvar uygulamaları ile yaratıcı düşünme boyutlarından olan özgünlük boyutunda en çok gelişme gösterdikleri ortaya konmuştur.

Anahtar sözcükler: Araştırmaya dayalı öğrenme, fen eğitimi, laboratuvar uygulamaları, yaratıcı düşünme.

ABSTRACT: The purpose of this research is to analyse the effects of Inquiry Based Laboratory Instructions on the development of creative thinking skills of pre-service teachers. In this study, one sample pre-test and post-test design which is non-experimental research model of quantitative analysis methods. The sample of the research is composed of thirty-six pre-service teachers in Science Education Program of The Faculty of Education at Pamukkale University. In this study, “Torrance Creative Thinking Test” is used in order to find out the development of their creative thinking levels. In the analysis of the data, frequency, arithmetic mean, standart deviation and t-test are used. At the end of the study it is found out that Inquiry Based Laboratory Instructions are effective in developing the all creative thinking aspects of the pre-service teachers such as fluency, flexibility and originality.

Key Words: Inquiry based learning, science education, laboratory instructions, creative thinking,

GİRİŞ

Olağan bir problemin farkında olan, bunun için ihtiyaç duyduğu bilgiye ulaşabilen, farklı çözümler üretebilen ve bunları hayata geçirebilen başka bir deyişle yaratıcı düşünebilen bireyler yetiştirmek fen eğitiminin en önemli amaçlarından biridir. Araştırmaya dayalı öğrenme ortamında öğrenciler yaparak yaşayarak kendi bilgilerini yapılandırır. Yaratıcılığın temeli de bireyin kendi bilgisini oluşturmasıdır. Bu anlamda eğitim uygulamaları, öğrencilerin yeteneklerini geliştirecek, onların öğrenmelerini kolaylaştıracak şekilde olmalıdır. Yaratıcılığın gelişmesinde rol alan öğretmenlerin de bu öğretim anlayışında yetişmesi önemlidir. Araştırmaya dayalı laboratuvar uygulamaları ile öğretmen adayları çok sayıda fikir üretebilme, çok yönlü düşünüp, düşüncelerini geliştirebilme ve sorunlara farklı açılardan bakarak yeni açılımlar getirebilme becerilerini geliştirirler.

Araştırmaya dayalı laboratuvar uygulamaları; problem çözme, analiz etme, genelleme, eleştirel düşünme, sentezleme, değerlendirme, karar verme ve yaratıcılık gibi bilişsel süreçleri geliştirir (Foulds ve Rowe, 1996). Araştırmaya dayalı laboratuvar uygulamalarıyla öğretmen adayları kendilerinin uyguladıkları deney ve etkinliklerle problem durumunu araştırırlar. Problem durumunun çözümüne yönelik planladıkları işlem basamaklarını takip eden öğretmen adayları kalıcı öğrenmeleri sağlayabilirler. Ayrıca bu uygulamalar onların araştırmayı, bilimsel düşünme becerileri kazanmayı ve bu düşüncelerini sınıfta akranları ile test etmeyi

öğrenmek için önemli fırsatlar sunmaktadır (Hofstein ve Lunetta, 2004; Kipnis ve Hofstein, 2007). Araştırmaya dayalı laboratuvar uygulamaları ile öğrenciler bilgi yığınının altında ezilmeden bilgiye ulaşmayı öğrenebilir, bilimsel çalışma disiplini ve anlayışını geliştirebilirler (Aktamış ve Ergin 2007).

Laboratuvar uygulamaları, öğretmenin problem durumunu söyleyip söylememesine, kullanılacak malzemeleri belirleyip belirlememesine, izlenecek yolu ve deneyin sonucunu açıklayıp açıklamamasına göre dört açıklık düzeyine sahiptir (Hegarty- Hazel, 1986; Tamir, 1989; Buck, Bretz, and Towns 2008). Yani araştırmaya dayalı laboratuvar uygulamaları, yüksek derecede yapılandırılmış ve öğretmen merkezli deneye dayalı etkinliklere doğru değişim göstermektedir (Hofstein ve Mamlok-Naaman, 2007). Laboratuvar uygulamalarında düzey "0" da problem, deneyin yöntem ve amacı, deneyin sonucu öğretmen tarafından veya çalışma yaprağı ile öğrencilere sunulur. Düzey "1"de problem ve deneyin yöntem ve amacı öğretmen tarafından belirlenir ve öğrencilerin uygulaması için açıklanır ancak deneyin sonucunun öğrenciler tarafından bulunması beklenir. Fakat burada deneyin sonucu zaten bellidir ancak öğrencinin bu sonuca ulaşması sağlanır.

Düzey "2"de ise problem öğretmen tarafından belirlenir ancak deneyin yöntemi, amacı ve sonucu öğrenciler tarafından belirlenir. Burada öğrenciler ortaya atılan probleme yönelik kendi deney düzeneklerini veya araştırmalarını oluşturur ve verilerini kendileri değerlendirerek daha önce bilmedikleri bir sonuca ulaşarak kavramsal açıklamada bulunurlar. Düzey "2" araştırma için kullanılacak malzemelerin öğrenciler tarafından belirlenip belirlenmemesine göre ikiye ayrılmaktadır. Düzey "2a" da araştırmaya yönelik problem durumu ve kullanılacak malzemeler öğrencilere sunulur ve öğrenciler kullanacakları yöntemi ve araştırmanın sonucunu kendileri belirler. Düzey "2b" ise yönlendirilmiş araştırmalardan açık araştırmalara geçiş düzeyi gibi düşünülebilir. Burada sadece problem durumu öğretmen tarafından belirlenir diğer süreçlerin hepsine öğrenci karar verir. Öğrencilerin kavramları anlama düzeylerini geliştirmek için, araştırmaya dayalı laboratuvarlar oluşturulmalıdır. Bu bağlamda öğretmenler araştırmaya dayalı bir laboratuvar ortamında öğrencilerin bilgilerini sentezlemelerine yardım etmeli, mantıksal tartışmalar oluşturmalı ve öğrencileri ile iyi bir iletişim içinde öğrenme ve öğretme ortamı sağlamalıdır.

Son olarak açıklık düzeyi en yüksek olan ve öğrencilerin bilişsel ve zihinsel gelişimini en çok etkileyen düzey "3" de araştırmanın problemini, yöntemini, amacını ve sonucunu öğrenci bizzat kendi belirler. Burada öğrenci aktif bir şekilde sürece katılır. Son yıllarda bu seviyeler değişik adlarla da adlandırılmaktadır. Seviye 0 ve seviye 1 yapılandırılmış araştırma (structured-inquiry), seviye 2 yönlendirilmiş araştırma (guided-inquiry), seviye 3 ise hiçbir yapı olmadığı için yapılandırılmamış (açık uçlu) araştırma (open-inquiry) olarak adlandırılmaktadır (Martin, Sexton ve Gerlovich, 1998; Basey, Mendelow ve Ramos, 2000; Bell, Smetana ve Binns Buck, 2005; Bretz, and Towns 2008; Herron, 2009; Gormally, Brickman, Hallar ve Armstrong, 2011).

Blomm'a göre yaratıcılığın gelişmesinde okulöncesi eğitim ve ilkököl yıllarıdır önemli bir yer tutmaktadır. Bu bağlamda öğretmenlerin öğrencilerinin yaratıcılıklarını geliştirebilmeleri için, her şeyden önce kendilerinin yaratıcı bir kişiliğe sahip, çocuklar için uygun bir model olmaları gerekmektedir. Araştırmaya dayalı öğrenmenin uygulamalarında anahtar rol üstlenen öğretmenlerin bilen insan rolünden çıkıp öğrencilerin ne düşündüğünü önemseyen ve öğrencilerinin öğrenmelerini geliştiren teşvik edici yanıtlar verebilen özelliklere sahip olmaları beklenir (Van Zee, Hammer, Bell, Roy ve Peter, 2005). Bu sebepten dolayı bu çalışmada da Fen Laboratuvar Uygulaması dersinde uygulanan araştırmaya dayalı öğrenme uygulamalarının öğretmen adaylarının yaratıcı düşünme düzeylerine etkisi araştırılmıştır.

YÖNTEM

Araştırmanın Modeli

Bu araştırmada Fen Laboratuvar Uygulaması-II dersinde uygulanan araştırmaya dayalı öğrenme etkinliklerinin öğretmen adaylarının yaratıcı düşünme düzeylerine olan etkisinin araştırılması amacıyla yarı deneysel araştırma modeli olan tek gruplu öntest-sontest deseni kullanılmıştır.

Örneklem

Pamukkale Üniversitesi İlköğretim Bölümü Fen Bilgisi Eğitimi Anabilim Dalı'nda 2009-2010 eğitim-öğretim yılının birinci döneminde Fen Laboratuvarı-I dersini almış ve ikinci döneminde Fen Laboratuvarı Uygulamaları-II dersine devam eden otuz altı öğretmen adayı oluşturmuştur. Örneklemi oluşturan öğretmen adaylarının 22'ü (%61.1) kadın, 14'ü (%38.9) ise erkektir.

Veri Toplama Aracı

Torrance yaratıcı düşünme testi (TYDT) Torrance tarafından ilk olarak 1966'da yayınlanmış ve 35 ayrı kültürde yaklaşık 615 araştırmada ve 100'den fazla lisansüstü tezde bireylerin yaratıcılık performanslarını tanımlamak, ölçmek ve değerlendirmek için kullanılmıştır (Akt. Sungur, 1997). Sungur'un (1988) belirttiğine göre Torrance (1966), test-tekrar test yöntemi ile yaptığı güvenilirlik çalışmasında, iki hafta ara ile yaptığı uygulamalar sonucunda 0,50 ile 0,93 arasında değişen sonuçlar elde etmiştir. Testin Türkçeye çevirisini yapan Aslan (1999) anaokulu, ilköğretim, lise ve yetişkinler için testin A ve B formlarının dil geçerliği, güvenilirlik ve geçerlik çalışmalarını yapmıştır. Bu çalışmalarda üç uzman tarafından form Türkçe'ye çevrilmiş ve çevrilen bu formlar karşılaştırılarak gerekli düzeltmeler yapılarak forma son hali verilmiştir. Torrance Yaratıcı Düşünce Testi Sözel A kısmı için 0.64 - 0.86 arasında değişen ve $p < .01$ düzeyinde anlamlı korelasyon değerleri bulunmuştur. Ayrıca testin İngilizce ve Türkçe form ortalamaları arası farklılık t-testi ile analiz edilmiştir. Testin güvenilirlik çalışması kapsamında test tekrar test yöntemi ile iç tutarlılığa bakılmış ve yetişkin formu için 0.68 ile 0.81 arasında değişen Cronbach alfa korelasyon katsayıları elde edilmiştir (Aslan, 2001; Aslan ve Puccio, 2006). Bu korelasyon katsayıları TYDT'nin güvenilir olduğunu göstermektedir. TYDT puanları üç farklı alt başlıkta incelenmektedir. "Sözel Akıcılık (Verbal Fluency)" bireyin sözcüklerle bir konu hakkında çok sayıda düşünce üretmesini, "Sözel Esneklik (Verbal Flexibility)" bireyin bir yaklaşımdan diğerine geçebilme esnekliğini ve "Sözel Özgünlük (Verbal Originality)" bilinenin, basitin ve anonim olanın ötesindeki düşünceleri ifade etmektedir. Bu araştırmada TYDT'nin "Sözel A" kısmı ön test ve son test olarak kullanılmıştır. TYDT Sözel A formunda 7 ayrı etkinlik bulunmaktadır. Bunlar; soru sorma, nedenlerini tahmin etme, sonuçlarını tahmin etme, ürün geliştirme, alışılmamış kullanımlar ve alışılmamış sorulardır.

Verilerin Analizi

Veri toplama araçlarından elde edilen veriler SPSS 13.0 paket programında yer alan farklı analiz yöntemleri kullanılarak değerlendirilmiştir. Araştırmadan elde edilen verilerin değerlendirilmesinde kullanılacak olan parametrik veya parametrik olmayan testler arasında seçim yapılabilmesi için öncelikle veri setlerinin normal dağılım gösterip göstermediğinin belirlenmesi için 'tek grup Kolmogorov-Smirnov Testi' uygulanmıştır (Baştürk, 2010). Verilerin çözümlenmesinde Torrance Yaratıcı Düşünce Testi'ne ait ön test ve son test puanları arasında anlamlı fark olup olmadığını ortaya koymak için "İlişkili Örneklem İçin t- Testi" (Paired Samples t-Test) kullanılmıştır.

BULGULAR

Bu araştırmada kullanılacak olan analiz yöntemine karar verilmesi için öncelikle öğretmen adaylarına öntest ve sontest olarak uygulanan Torrance Yaratıcı Düşünme Testi (TYDT) ile elde edilen verilerin normal dağılım gösterip göstermediğinin belirlenmesi gerekmektedir. Bu amaçla ön testlerden ve son testlerden elde edilen verilere "Tek Grup Kolmogorov-Smirnov Testi" uygulanmıştır. Bu testten elde edilen sonuçlar Tablo-1.'de sunulmuştur.

Tablo 1: Tek Grup Kolmogorov-Smirnov Testi Sonuçları

TYDT	Ön Test				Son Testler			
	N	X	S.S	p	N	X	S.S	p
	36	22.37	.94	6.09	36	40.38	16.56	.07

Tablo 1 incelendiğinde ölçüm aracına ait tüm ön test ve son test sonuçlarının normal dağılım gösterdiği ($p > 0,05$) belirlenmiştir. Bu nedenle araştırmaya ait verilerin analizlerinde parametrik testler uygulanmıştır.

Tablo 2: Öğretmen adaylarının Ön Teste İlişkin Toplam Akıcılık, Esneklik ve Orijinallik Puanlarına Göre Hesaplanmış Ortalama, Standart Sapma, Minimum ve Maksimum Değerleri

	N	X	S.S	En Düşük Puan	En Yüksek Puan
Akıcılık	36	33.66	8.50	15.00	59.00
Esneklik		20.55	6.07	9.00	30.00
Özgünlük		12.88	6.93	2.00	29.00

Öğretmen adaylarının ön teste ait akıcılık, esneklik ve orijinallik düzeylerindeki puanlarının aritmetik ortalama değerleri Tablo 2' de sunulmuştur. Bu değerlerin, en yüksek puandan başlayarak akıcılık ($X_{ort} = 33.66$), esneklik ($X_{ort} = 20.55$) ve özgünlük ($X_{ort} = 12.66$) olarak sıralandığı görülmektedir. Öğretmen adaylarının ön testten aldıkları puanlara bakıldığında endüyük puanı özgünlük düzeyinde (2 puan), en yüksek puanı da akıcılık düzeyinde (59 Puan) aldıkları görülmektedir.

Tablo 3: Öğretmen adaylarının Ön Teste İlişkin Toplam Akıcılık, Esneklik ve Orijinallik Puanlarına Göre Hesaplanmış Ortalama, Standart Sapma, Minimum ve Maksimum Değerleri

	N	X	S.S	En Düşük Puan	En Yüksek Puan
Akıcılık	36	48.25	18.82	22.00	117.00
Esneklik		29.05	9.78	11.00	60.00
Özgünlük		43.86	23.04	10.00	121.00

Öğretmen adaylarının son teste ait akıcılık, esneklik ve orijinallik düzeylerindeki puanlarının aritmetik ortalama değerleri Tablo 2’ de sunulmuştur. Bu değerler incelendiğinde en yüksek puandan başlayarak akıcılık ($X_{ort}=48.25$), esneklik ($X_{ort}=29.05$) ve özgünlük ($X_{ort}=43.86$) olarak sıralandığı görülmektedir.

Ayrıca öğretmen adaylarının son testten en düşük puanı özgünlük düzeyinde (10 puan), en yüksek puanı da yine özgünlük düzeyinde (121 puan) aldıkları görülmektedir. Bu sonuca göre, öğretmen adaylarının bilinenin dışına çıkan fikirler üretmekte daha başarılı oldukları söylenebilir. Araştırmaya katılan öğretmen adaylarının TYDT’ne yönelik almış oldukları öntest ve sontest puanları ilişkili örneklem için t testi ile karşılaştırılmış ve sonuçlar Tablo 4’de sunulmuştur.

Tablo 4. Araştırmaya Katılan Öğretmen Adaylarının TYDT Puanlarının Ortalamaları, Standart Sapmaları ve t-testi Sonuçları

Yaratıcılık Alt Boyutları		N	X	S.S	S.H	t	p
Akıcılık	Ön test	36	33.66	15.89	2.64	-5.50	.001*
	SonTest		48.25				
Esneklik	Ön test		20.55	8.04	1.40	-6.06	.001*
	SonTest		29.05				
Özgünlük	Ön test		12.88	22.22	3.70	-8.36	.001*
	SonTest		43.86				

*($p < .05$)

Tablo 4 incelendiğinde testin akıcılık boyutunda ($t=-5.50$, $p<0.05$), esneklik boyutunda ($t=-6.06$, $p<0.05$) ve özgünlük boyutunda ($t=-8.36$, $p<0.05$) ön ve son test puanları arasında, son test lehine istatistiksel olarak anlamlı bir farklılığın olduğu bulunmuştur. Bu sonuca göre; öğretmen adaylarına uygulanan araştırmaya dayalı laboratuvar uygulamalarının yaratıcı düşüncelerini geliştirmede etkili olduğu görülmüştür.

SONUÇ ve YORUM

Bu çalışmada araştırmaya dayalı laboratuvar uygulamalarının öğretmen adaylarının yaratıcı düşünme düzeylerine olan etkisi incelenmiştir. Öğretmen adaylarının TYDT’ne ön testine ait akıcılık, esneklik ve orijinallik düzeylerindeki puanlarının aritmetik ortalama değerleri incelendiğinde en yüksek puandan başlayarak akıcılık, esneklik ve özgünlük olarak sıralandığı görülmektedir. Öğretmen adayları bu testten en düşük puanı özgünlük düzeyinde, en yüksek puanı da akıcılık düzeyinde aldıkları belirlenmiştir. Bu sonuca göre öğretmen adaylarının fikir üretmede diğer iki düzeye oranla daha başarılı oldukları tespit edilmiştir. Diğer taraftan araştırmaya dayalı laboratuvar uygulamaları sonrasında öğretmen adaylarının TYDT son testinin akıcılık, esneklik ve orijinallik düzeylerine ait puanların aritmetik ortalama değerleri incelendiğinde ise en yüksek puanın akıcılık boyutunda olduğu ve bunu özgünlük ve esnekliğin takip ettiği ortaya konmuştur. Bu sonuca göre, öğretmen adaylarının bilinenin dışına çıkan orijinal fikirler üretmekte daha başarılı oldukları söylenebilir.

Öğretmen adaylarının TYDT’nin akıcılık düzeyinde ön test ve son test sonuçları karşılaştırıldığında son test lehine bir gelişmenin olduğu belirlenmiştir. Bu sonuçtan yola çıkarak öğretmen adaylarının yaratıcı düşünme akıcılık düzeyinin gelişiminde araştırmaya dayalı laboratuvar uygulamalarının etkili olduğu söylemek mümkündür. Yani öğretmen adayları araştırmaya dayalı laboratuvar uygulamaları ile belli bir süre içinde çok sayıda kabul edilebilecek düşünce, çözüm veya alternatifler üretme becerilerini geliştirmişlerdir. Tartışan, soru soran, yaratıcı düşünmeyi öğrenen öğretmen adayları gelecekte de öğrencilerine olaylara farklı bakış açılarıyla bakabilmeyi kazandırabileceklerdir. Bu anlamda bu çalışmada araştırılan araştırmaya dayalı laboratuvar uygulamalarının, öğretmen adaylarının bir olaya yönelik birçok problem durumunu ortaya koyabilmelerinde ve problemlerin çözümüne yönelik birçok düşünce sunabilmelerinde etkili olduğu tespit edilmiştir. Bu çalışma sonuçlarına benzer sonuçlar Tezci’nin (2002) ve Aboukinane’ nin (2007) yapmış olduğu çalışmalarda da

görülmektedir. Fen öğretiminde öğrencilerin yaparak yaşayarak bilgileri kavramaları önemli olduğundan daha derin anlamlar kazanabilmek için olaylardaki farklı durmaları görebilmeli ve her zaman sorunun birden fazla çözüm yolu olduğunu bilmelidir.

Öğretmen adaylarının TYDT'nin esneklik düzeyinde ön test ve son test sonuçları karşılaştırıldığında son test lehine bir gelişmenin olduğu belirlenmiştir. Bu da öğretmen adaylarının yaratıcı düşünme esneklik düzeyinin gelişiminde araştırmaya dayalı laboratuvar uygulamalarının etkili olduğunu göstermiştir. Başka bir deyişle araştırmaya dayalı laboratuvar uygulamaları, öğretmen adaylarının farklı türe ve sınıflara ait düşünce ve çözümler üretme becerilerini geliştirmiştir.

Alışılmışın dışında yeni, özgün, sıra dışı çözümler üretebilmeyi içeren TYDT'nin özgünlük düzeyinde de diğer yaratıcılık düzeylerinde olduğu gibi son test lehine bir gelişme olduğu tespit edilmiştir. Bu çalışmada öğretmen adayları araştırmaya dayalı laboratuvar uygulamaları ile alışılmadık, benzersiz yani kendine özgü düşünceler, problemler veya çözümler üretme imkanı bulmuşlardır. Bu süreç onların özgün düşünceler sunabilme becerilerini geliştirmiştir. Öğretmen adaylarının bu beceriyi kazanmaları sadece kendi öğrenmelerinde önemli olmayacaktır aynı zamanda gelecekte öğrencilerine sadece fen konularına yönelik değil yaşantılarının her alanında farklı düşünceleri ortaya koyabilmeleri açısından da önemlidir. Bu sonuç araştırmaya dayalı laboratuvar uygulamalarının öğretmen adaylarının yaratıcı düşünme özgünlük düzeyinin gelişiminde etkili olduğunu ortaya koymuştur.

ÖNERİLER

Geleceğin öğretmenleri olan öğretmen adaylarının yaratıcı düşüncelerini geliştirecek öğretim ortamları sağlanarak onların da öğrencilerini bu öğrenme ortamını oluşturabilmelerine imkan verilmelidir.

Bu çalışma sadece Fen Bilgisi Eğitimi Anabilim Dalında öğrenimine devam eden 36 öğretmen adayıyla sınırlanmıştır. Gelecekte daha fazla öğretmen adayı ile bu çalışmanın tekrarlanması önerilebilir. Ayrıca aynı çalışma farklı disiplinlerde öğrenim gören öğretmen adayları ile tekrarlanabilir. Bu çalışmada toplanan veriler nicel analiz yöntemleriyle analiz edilmiştir. Gelecek çalışmalarda nicel veriler nitel verilerle desteklenebilir.

KAYNAKLAR

- Aslan, E. (2001). Torrance Yaratıcı Düşünce Testinin Türkçe Versiyonu. *M.Ü. Atatürk Eğitim Fakültesi Eğitim Bilimleri Dergisi*, 14, 19-40.
- Aslan, A. E. Ve Puccio, G. J. (2006). Developing And Testing A Turkish Version Of Torrance's Tests Of Creative Thinking: A Study Of Adults. *The Journal Of Creative Behavior*, 40, 163-178.
- Aboukına, C. (2007). A Qualitative Study Of Creative Thinking Using Experiential Learning In An Agricultural And Life Science Course. Doktora Tezi. *Texas A&M University*.
- Aktamış, H., Ve Ergin, Ö., (2007). Bilimsel Süreç Becerileri İle Bilimsel Yaratıcılık Arasındaki İlişkinin Belirlenmesi (Investigating The Relationship Between Science Process Skills And Scientific Creativity). *Hacettepe Üniversitesi Eğitim Fakültesi Dergisi (H. U. Journal Of Education)*, 33: 11-23.
- Basey, J.M., Mendelow, T.N., & Ramos, C.N. (2000). Current Trends Of Community College Lab Curricula in Biology: An Analysis Of Inquiry, Technology, And Content. *Journal Of Biological Education*, 34(2), 80-86.
- Baştürk, R. (2010). Nonparametrik İstatistiksel Yöntemler. *Anı Yayıncılık*, Ankara.
- Bell, L. R., Smetana, L., & Binns, I. (2005). Simplifying Inquiry Instruction: Assessing The Inquiry Level Of Classroom Activities. *The Science Teacher*, 72(7), 30-33.
- Bretz S. L., Smith C. And Nakhleh M. B., (2004). Analysis Of The ACS Blended General Chemistry Exams Using A New Coding Framework, Paper Presented At The 227th American Chemical Society National Meeting.
- Foulds, W. Ve Rowe, J. (1996). The Enhancement Of Science Process Skills in Primary Teacher Education Students. *Australian Journal Of Teacher Education*, 21(1), 16-23.
- Gormally, C., Brickman, P., Hallar, B. & Armstrong, N. (2011). Lessons Learned About Implementing An Inquiry-Based Curriculum in A College Biology Laboratory Classroom. *Journal Of College Science Teaching*, 40(3), 45-51.
- Hegarty-Hazel, E. (1986). Lab Work. SET: Research Information For Teachers, Number One. Canberra: Australian Council For Education Research.
- Herron, Sherry S. (2009). From Cookbook To Collaborative: Transforming A University Biology Laboratory Course. *American Biology Teacher*, 71(9), 548-552.

- Hofstein A. And Lunetta V.N., (2004). The Laboratory in Science Education: Foundation For The 21st Century, *Science Education*, 88, 28-54.
- Hofstein, A., & Mamlok-Naaman, R. (2007). The Laboratory in Science Education: The State Of The Art. *Chemistry Education: Research And Practice In Europe*, 8(2), 105-108.
- Martin, R., Sexton,C., & Gerlovich, J. (1998). *Science For All Children: Instruction Practices For Constructing Understanding*. Boston: Allyn.
- Sungur, N. (1988). *Yaratıcı Sorun Çözme Programının Etkililiği : (EYT Öğrencilerine İlişkin Bir Deneme)*. Yayınlanmamış Doktora Tezi, *Ankara Üniversitesi Sosyal Bilimler Enstitüsü*, Eğitim Yönetimi ve Planlaması Anabilim Dalı.
- Sungur, N. (1997). *Yaratıcı Düşünce*. *Evrin Yayınları*, İstanbul.
- Tezci, E. (2002). *Oluşturmacı Öğretim Tasarım Uygulamasının İlköğretim Beşinci Sınıf Öğrencilerinin Yaratıcılıklarına Ve Başarılarına Etkisi*. Yayınlanmamış Doktora Tezi, *Fırat Üniversitesi Sosyal Bilimler Enstitüsü*, Elazığ.
- Torrance, E. P. (1962). *Guiding Creative Talent* Englewood Cliffs. N. J, Prentice Hail.
- Torrance, E. P. Ve Goff, K. (1989). A Quiet Revolution. *Journal Of Creative Behavior* 23(2), 136-145.
- Tamir, P. (1989), *Training Teachers To Teach Effectively In The Laboratory*. Science
- Van Zee, E.H., Hammer, D., Bell, M., Roy, P., Ve Peter, J. (2005). Learning And Teaching Science As Inquiry: A Case Study Of Elementary School Teachers' Investigations Of Light. *Science Education*, 89, 1007–1042. [Http://Onlinelibrary.Wiley.Com/Doi/10.1002/Sc.20084/Pdf](http://Onlinelibrary.Wiley.Com/Doi/10.1002/Sc.20084/Pdf) Education, 73: 59–69.

PROSPECTIVE ELEMENTARY TEACHERS' PERCEPTIONS OF USING TECHNOLOGY IN THE TEACHING OF MATHEMATICS

Nurhayat GÜREL

Mermet Akif Ersoy Üniversitesi, Eğitim Bilimleri Enstitüsü, Sınıf Öğretmenliği Programı
gurelnurhayat@gmail.com

Osman EROL

Mermet Akif Ersoy Üniversitesi, Eğitim Fakültesi, Bilgisayar ve Öğr. Tek Eğt. Bölümü
oerol@mehmetakif.edu.tr

Ramazan GÜREL

Mermet Akif Ersoy Üniversitesi, Eğitim Fakültesi, İlköğretim Bölümü
rgurel@mehmetakif.edu.tr

ABSTRACT: Technology is an essential tool for learning mathematics in the 21st century, and all schools must ensure that all their students have access to technology. In this study, it was aimed to determine the perceptions of preservice elementary school teachers on the use of technology in mathematics teaching and explore whether these perceptions were significantly associated with certain variables (gender, grade level, and frequency and adequacy ICT use). The sample of the research was composed of 252 prospective elementary school teachers. A “a perception scale for technology use in the teaching of mathematics” which was composed of requirement, advantage and disadvantage sub-dimensions, was used as the data collection tool. The data were analyzed for descriptive statistics, t-test, Mann-Whitney U, ANOVA and Kruskal-Wallis H test. Preliminary analyses indicated that the perceptions of prospective teachers on the use of technology in mathematics teaching were positive in the general perceptions, requirement and advantage sub-dimensions whereas their perceptions on the use of technology in mathematics teaching were negative in the disadvantage sub-dimension.

Key words: Prospective Teachers, Technology Usage, Mathematics Instruction, Perceptions

USING SLOWMATION AS A TEACHING APPROACH AND ITS EFFECT ON BIOLOGY ACHIEVEMENTS OF PRE-SERVICE SCIENCE TEACHERS

Fatma TAŞKIN EKİCİ
Pamukkale University
fekici@pau.edu.tr

Nimet ÖZCAN ÇAKMAK
Pamukkale University (M.S. Student)

Erhan EKİCİ
Pamukkale University
eekici@pau.edu.tr

ABSTRACT: Digital technologies offer increasing opportunities for students in primary or secondary schools to create their own digital media. “Slowmation” (abbreviated from “Slow Motion Animation”) is a simplified way of making an animation so that students, themselves, can create it as a new way of learning about some science concepts.

In this study, pre- and post-test quasi-experimental design with control group was used with retention test. During the study, for the experimental group of students, additionally to biology instruction, slowmation has been used as a teaching approach. The implementation lasted 9 weeks. The data gathered by an 18 question-multiple choice test. It was developed by researcher and used as pre-, post- and retention test in order to measure students’ biology course achievement. As a result of the research, it was determined that using slowmations as teaching approach for biology instruction increased the students’ biology course achievement more significantly for post- and retention implementations.

Key words: Slowmation, Science Teacher, Pre-service Teacher

INTRODUCTION

Using technology that is readily accessible can sometimes be a catalyst for such engagement, especially if the tools help pre-service teachers to represent their knowledge in innovative ways (Kim & Reeves, 2007; Lee, Linn, Varma, & Liu, 2010). With the rapid advancement in personal digital technologies, it is becoming easier for students such as pre-service teachers to design media products such as animations and videos, which may be a way to support their conceptual understanding of science concepts that are typical in the primary school curriculum (Hoban & Nielsen, 2012). In several studies involving animations made by experts to assist students in learning science concepts have produced mixed results. Some studies have shown that watching animations to explain science concepts has improved the knowledge of high school and college students (Marbach-Ad, Rotbain, & Stavy, 2008; Williamson & Abraham, 1995). But in some studies, contrarily, it has been found that there has been little improvement in learning when students watch animations explaining science concepts (Sanger & Greenbowe, 2000; Yang, Andre, Greenbowe, & Tibell, 2003). According to Chan and Black (2005), animations could provide a motivation for engaging with content if learners become the designers and creators rather than consumers of information as in expert generated animations. Although this possibility of motivation for engaging with the content, designing and creating students’ own animations have been limited because, this process requires time and sophisticated software and the process is too complex (Hoban & Nielsen, 2012).

Slowmation

Slow Motion Animation (abbreviated to “Slowmation”) is a new teaching approach that has been developed over the last decade in science education classes at the University of Wollongong. This approach simplifies the complex process of making animations to enable learners to create their own comprehensive animations about science concepts (Hoban, 2005, 2007, 2009; Hoban & Ferry, 2006). Slowmation technic is similar to clay animation and in this approach, students make research, storyboard, design models, capture digital still images of small manual movements of the models. After these, they use a computer software to play the images in a sequence to simulate movement.

Making a movie using a traditional stop-motion animation technique is feasible, because the creator who manually moves the objects while taking each digital still photograph, thus eliminates the need for complex

mechanisms to provide movement. Having pre-service teachers take digital still photos one by one, instead of a continuous 25–30 frames per second as in video, also allows them to check, manipulate, think about, discuss and reconfigure the models with each movement and photograph (Hoban & Nielsen, 2011).

Pre-service teachers can learn the process at the beginning of a course period and can prepare their models made out of daily routine materials such as plasticine, paper, and existing plastic models. If the materials are ready and available, in the course period, they can continue and take digital photos as the models are moved manually. The creation process integrates features of clay animation, object animation and digital storytelling and involves the pre-service teachers in designing and a sequence of representations (Hoban and Nielsen, 2010); (a) research notes, (b) storyboard, (c) models, (d) digital photographs and (e) narrated animation.

In summary, slowmation greatly simplifies the process of creating a stop-motion animation by enabling pre-service teachers to (i) make or use existing 2-D or 3-D models that may lie flat on a table or the floor; (ii) play the animation slowly at 2 frames per second requiring 10 times fewer photos than required in normal animation and (iii) use widely available technology such as a digital still camera, a tripod and free movie-making computer software (Hoban & Nielsen, 2012). McKnight, Hoban and Nielsen (2011), have explained that a slowmation displays the following features:

- *Purpose* - the goal of a slowmation is for pre-service teachers to make use of 1-2 minute animated mini-movie to tell a story, and through the creation process, learn about the story's meaning. The design of the slowmation can include a range of technological enhancements such as narration, music, other photos, diagrams, models, labels, questions, static images, repetitions and characters.
- *Timing* - slowmations are usually played slowly at 2 frames/second, not the usual animation speed of 20-24 frames/second, and thus need ten times fewer photos than in clay or computer animation, hence the name "Slow Animation" or "Slowmation";
- *Orientation* - models are made in 3D and/or 2D and usually manipulated in the horizontal plane (on the floor or on a table) and photographed by a digital still camera mounted on a tripod looking down or across at the model. This makes the models easier to make, move and photograph;
- *Materials* - because models do not have to stand up, many different materials can be used such as soft play dough, plasticine, 2D pictures, drawings, written text, existing 3D models, felt, cardboard cut-outs and natural materials such as leaves, rocks or fruit; and,
- *Technology* – pre-service teachers use their own digital still cameras (with photo quality set on low resolution so as to avoid overloading the editing software) or cameras in mobile phones and free movie-making software available on their computers (e.g. *iMovie* or *SAM Animation* on a Mac or *Windows Movie Maker* on a PC)

Purpose of the Study

The purpose of this study is to determine whether the approach is effective on students' success in some biology content or not. For this aim, following research question has been examined to conduct this study.

How does the slowmation approach influence pre-service teachers' biology achievement?

METHODS

Research Design

This study used a quasi-experimental (two-group pretest–posttest) design to compare the effects of slowmation as teaching and learning approach in biology achievement of pre-service science teachers.

Participants

This study was conducted in fall semester of 2013 and used quasi-experimental (pre- and post-test control group design) study design to examine the effects of slowmation in learning biology and students biology achievement. No specific exclusion criteria were identified. Experimental and control group participants were identified on the base of volunteerism. After a short information was given about the slowmation application in computer course, students were asked to select one of the two classes.

The pre-service teachers were enrolled in one semester Computer course in the second year of a four year Education Faculty. The students were also enrolled in General Biology course in the same semester. In this study, the forty nine pre-service science teachers were invited to be in the research project for making slowmations as experimental group and 45 of them volunteered. On the other hand, the control group was for 38 pre-service science teachers. The pre-service teachers in experimental group received a workshop to explain how they could create a slowmation. Pre-service science teachers were allocated typical biology topics (e.g., mitosis, meiosis, reproduction) which were selected from general biology course content after the workshop.

They were expected to create a 2–4 minutes narrated slowmation as one assessment task to explain a science concept from their allocated topic.

Instrument and Data Collection

Data of this research gathered by biology achievement test. The test was multiple choice for 18 items. The biology achievement test for 25 items was applied as a pilot study to the students (n=63) who completed the basic biology course at the end of the previous semester (spring semester of 2012) and after the item analysis, 7 items were excluded from the test. This multiple choice biology achievement test was applied as pre- and post-test. The biology achievement test was used again to examine the permanency two months later.

Table 1. The Data Collection and Application Process of the Study

Groups	Pre-Test	Slowmation Creation	Post-Test	Retention Test
Control (n=38)	X	→	X	X
Experimental (n=45)	X	X	X	X

Data Analysis

The data gathered from pre-service science teachers were analyzed using the SPSS Software (v.16.0). Descriptive statistics were calculated to summarize the sample characteristics and the subjects' answers. To assess mean differences between pre- and post- and retention test biology achievement scores for each groups, paired sample t-Test was used. To compare the mean difference of experimental and control group, (binary comparisons of pre- and post- and retention-test), independent samples t-test were used. For all analyses, $p < .05$ was considered statistically significant.

RESULTS AND FINDINGS

The means and standart deviations of biology achievement scores of two groups (experimental and control) for pre- and post- and retention-test measurements were given in Table 2.

Table 2. Descriptive statistics of biology achievement for two treatment groups

Group	Pre-Test Mean (SD)	Post-Test Mean (SD)	Retention Test Mean (SD)
Control	6,82 (3,83)	7,47 (3,51)	6,97 (2,75)
Experimental	5,73 (2,85)	9,56 (3,00)	7,76 (2,68)

As can be seen from Table 2, the mean scores of biology achievement test increased from pre to posttest measurement for both group and decreased from post to retention test. According to Table 2, for the control group, only a small amount of the mean score changes occurred among the pre-, post- and retention test measurements.

Paired samples t-Test was carried out on to determine the difference in the pre- and post- and retention-test measurements of biology achievement for each groups (control and experimental). In other words, t-Test was performed to investigate the effect of slowmation approach on the biology achievement of the pre-service science teachers. The results are shown in the following table (See; Table 3 and Table 4).

As seen in the Table 3, there was a significant difference in the scores for pre-test (M=6.82, SD=3.83) and post-test (M=7.47, SD=3.51) conditions; $t(37) = -2.749$, $p = 0,009^*$. There were not significant differences in the scores for post-test (M=7.47, SD=3.51) and ret-test (M=6.97, SD=2.75) conditions; $t(37) = 0.705$, $p = 0,485$ and for pre-test (M=6.82, SD=3.83) and ret-test (M=6.97, SD=2.75) conditions; $t(37) = -0.197$, $p = 0,845$.

Table 3. Paired Samples t-Test Results for Control Group

For Control Group	n	X	SD	df	t	p
----------------------	---	---	----	----	---	---

Pre-test	38	6,82	3,83	37	-2,749	,009
Post-test	38	7,47	3,51			
Post-test	38	7,47	3,51	37	,705	,485
Ret-test	38	6,97	2,75			
Pre-test	38	6,82	3,83	37	-,197	,845
Ret-test	38	6,97	2,75			

When same analysis were done for experimental group, as seen in the Table 4, there were significant differences in the scores for pre-test (M=5.73, SD=2.85) and post-test (M=9.56, SD=3.01) conditions; $t(44) = -5.642$, $p = 0,000^*$ and for post-test (M=9.56, SD=3.01) and ret-test (M=7.76, SD=2.68) conditions; $t(37) = 0.705$, $p = 0,485$ and for pre-test (M=6.82, SD=3.83) and ret-test (M=6.97, SD=2.75) conditions; $t(37) = -0.197$, $p = 0,845$.

Table 3. Paired Samples t-Test Results for Experimental Group

For Experimental Group	n	X	SD	df	t	p
Pre-test	45	5,73	2,85	44	-5,642	,000
Post-test	45	9,56	3,01			
Post-test	45	9,56	3,01	44	3,203	,003
Ret-test	45	7,76	2,68			
Pre-test	45	5,73	2,85	44	-3,179	,003
Ret-test	45	7,76	2,68			

The mean scores for treatment groups in pre- and past- and retention-test measurement were summarized below (Figure 1).

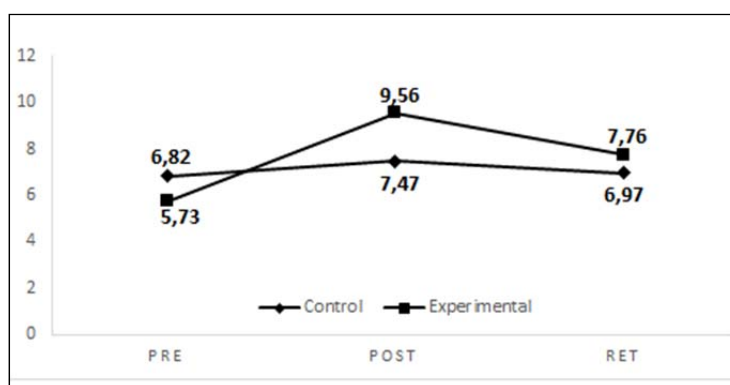

Figure 1. Mean Scores of Control and Experimental Groups in Pre- and Past- and Retention Test

Binary Comparisons of the Mean Scores of Control and Experimental Groups

Table 4 shows how to combine results from several t-tests performed for the same groups. According to Table 4, there are statistically significant differences, at the .05 level of significance, between control and experimental group students in biology achievement scores, but not pre- and retention-test. Results show that experimental group students had higher achievement scores, but no statistical difference exists between control and experimental groups in pre- and retention-test in terms of biology achievement scores.

Table 4. Results of t-test and Descriptive Statistics for pre- and post- and retention-test by groups

	Groups						95% CI for Mean Difference	t	df	p
	Control			Experimental						
	M	SD	n	M	SD	n				
Pre-Test	6,82	3,826	38	5,73	2,85	45	-0.418, 2.54	1.439*	67,321	0,155
Post-Test	7,47	3,51	38	9,56	3,01	45	-3.50, -0.66	-2,913	81	0,005
Ret-Test	6,97	2,75	38	7,76	2,68	45	-1.97, 0.41	-1,309	81	0,194

* Second row values were used because equal variance not assumed ($p < .05$).

CONCLUSION

With the lack of empirical studies related to effect of slowmation creation process as a teaching and learning approach, this study introduced the results of quasi-experimental research design. According to the results of study, slowmation approach has positive influence on students' biology achievement. Besides, the contribution of slowmation approach to the achievement of students who creates them, when we think about the increasing in whole group mean scores, we should take into account the effect of presentation and discussion after presentation phases. As a result, "we should not teach them, they should learn themselves". Although there were no significant differences between the mean scores of pre- and retention-test and between the mean scores pre- and ret-test measurements, there were between the mean scores of pre- and post-test for control group and between all of the mean scores of experimental group.

RECOMMENDATIONS

Both experimental researches and use of this approach in teacher training and/or in middle and high school should be increased.

ACKNOWLEDGEMENT

As the authors of this report, we gratefully acknowledge the support from the Universtiy of Pamukkale for the participation to this symposium (project code: 2013KRM024).

REFERENCES

- Chan, M.S., & Black, J.B. (2005). When can animation improve learning? Some implications for human computer interaction and learning. In P. Kommers & G. Richards (Eds.), *Proceedings of World Conference on Educational Multimedia, Hypermedia and Telecommunications 2005* (pp. 2581–2588). Chesapeake, VA: Association for the Advancement of Computing in Education.
- Hoban, G. & Ferry, B. (2006). Teaching Science Concepts in Higher Education Classes with Slow Motion Animation (Slowmation), Paper presented at the E-Learn, Conference for e learning in higher education, Business Honolulu, Hawaii.
- Hoban, G., & Nielsen, W. (2011). Engaging preservice primary teachers in creating multiple modal representations of science concepts with 'slowmation'. *Research in Science Education*. doi:10.1007/x11165-011-9236-3.
- Hoban, G. & Nielsen, W. (2012): Learning Science through Creating a 'Slowmation': A case study of preservice primary teachers, *International Journal of Science Education*, DOI:10.1080/09500693.2012.670286
- Hoban, G. (2005). From claymation to slowmation: A teaching procedure to develop students' science understandings. *Teaching Science: Australian Science Teachers' Journal*, 51(2), 26–30.
- Hoban, G. (2007). Using slowmation to engage preservice elementary teachers in understanding science content knowledge. *Contemporary Issues in Technology and Teacher Education*, 7(2), 1–9.
- Hoban, G. (2009). Facilitating learner-generated animations with slowmation. In L. Lockyer, S. Bennett, S. Agostino, & B. Harper (Eds.), *Handbook of research on learning design and learning objects: Issues, applications and technologies* (pp. 313–330). Hershey, PA: IGI Global.

- Kim, B., & Reeves, T. (2007). Reframing research on learning with technology: In search of the meaning of cognitive tools. *Instructional Science*, 35, 207–256.
- Lee, H., Linn, M., Varma, K., & Liu, O. (2010). How do technology-enhanced inquiry science units impact classroom learning? *Journal of Research in Science Teaching*, 47, 71–90.
- Marbach-Ad, G., Rotbain, Y., & Stavy, R. (2008). Using computer animation and illustration activities to improve high school students' achievement in molecular genetics. *Journal of Research in Science Teaching*, 45, 273–292.
- McKnight, A., Hoban, G., & Nielsen, W. (2011). Using *Slowmation* for animated storytelling to represent non-Aboriginal pre-service teachers' awareness of "relatedness to country", *Australasian Journal of Educational Technology*, 27(1), 41-54
- Sanger, M., & Greenbowe, T. (2000). Addressing student misconceptions concerning electron flow in aqueous solutions with instruction including computer animations and conceptual change strategies. *International Journal of Science Education*, 22, 521–537.
- Williamson, V., & Abraham, M. (1995). The effects of computer animation on the particulate mental models of college chemistry students. *Journal of Research in Science Teaching*, 32, 521–534.
- Yang, E., Andre, T., Greenbowe, T., & Tibell, L. (2003). Spatial ability and the impact of visualization/animation on learning electrochemistry. *International Journal of Science Education*, 25, 329–349.

ÇOCUKLARIN TEMİZ VE KİRLİ ÇEVRE ALGILARI

STUDENTS' VIEWS ABOUT CLEAN AND UNCLEAN ENVIRONMENTS

Gülcan ÇETİN
Balıkesir Üniversitesi
gulcan_cetin@hotmail.com

Neşe BADEM
Balıkesir Üniversitesi
nese.76@hotmail.com

ÖZET: Bu çalışma, iki yıllık bir çalışma olup, öğrencilerin ikinci ve üçüncü sınıftaki temiz ve kirli çevre ile ilgili görüşlerini belirlemek amacıyla yapılmıştır. Çalışma grubu, 2007-2008 Eğitim-Öğretim Yılı Güz Dönemi'nde Balıkesir'e bağlı bir köy ilköğretim okulunda öğrenim gören 11 ikinci sınıf öğrencisinden oluşmaktadır. Veriler, doküman analizi, resim çalışması ve yapılandırılmamış görüşme teknikleri kullanılarak toplanmıştır. Çalışmanın ilk yılında; çevre ile ilgili kavramlar, konular ve etkinliklerin belirlenmesi amacıyla 2. ve 3. sınıf Hayat Bilgisi ve Türkçe Ders Kitapları ile Öğrenci Çalışma Kitapları incelenmiştir. Daha sonra, ikinci sınıf öğrencilerine temiz çevre ve kirli çevre konulu resimler yaptırılmıştır. Son olarak, öğrencilerle yaptıkları resimler hakkında yapılandırılmamış görüşmeler yapılmıştır. Çalışma, aynı öğrenciler üçüncü sınıfa geçtiklerinde tekrar edilmiştir. Veri analizinde, doküman analizi ve içerik analizi teknikleri kullanılmıştır. Elde edilen bulgulara göre, öğrencilerin temiz çevre ve kirli çevreye ilişkin görüşlerinin yaşa göre değiştiği sonucuna varılmıştır.

Anahtar sözcükler: temiz çevre, kirli çevre, resim çalışması, görüşme, ilköğretim

ABSTRACT: The aim of the study was to investigate the second and third grade students' views about clean and unclean environments. This study was a two-year longitudinal study. Study group included 11 second grade students in a rural primary school in Balıkesir in 2007-2008 academic years. Data were collected by document analysis, drawing pictures and unstructured interview techniques. In the first year of the study, 2 and 3 grade Social Studies and Turkish Textbooks and Students Workbooks were examined in order to determine the concepts, subjects, and activities related to environment. Then, second grade students were asked to draw pictures of clean and unclean environments. Finally, unstructured interviews were conducted with students about their pictures. The study was again conducted with the same group of the students when they were in the third grade. Data were analyzed by using content analysis and descriptive analysis techniques. The study results showed that the students' perceptions related to clean and unclean environments varied by age.

Key words: clean environment, unclean environment, drawing picture, interview, primary education

ERADICATING MATHEMATICS ANXIETY AMONG SECONDARY SCHOOL STUDENTS USING COGNITIVE BEHAVIOURS THERAPY (CBT)

DR.(MRS). Philomina .I. ONWUKA
Mathematics Department College of Education, Agbor, Nigeria
philonwuka@yahoo.com

MRS. Pauline I. TIBI
Psychology Department College of Education, Agbor, Nigeria

ABSTRACT: Achievement in Mathematics to a large extent, is a function of examination anxiety, teachers' instructional strategy, among other variables. The Onus of this paper is to empirically document the effectiveness of CBT in curbing mathematics anxiety in students in Nigeria. A sample of 154 students was composed. The instrument used is Mathematics Anxiety Test Scale (MATS). The reliability coefficient of 0.83 was obtained. The 154 students were pretested and those (68) who scored 24 and above were assigned to experimental group. Two research questions and two hypotheses guided the study. Research questions were addressed using mean and standard deviation while hypotheses were tested with t-test, ANCOVA. The result indicates a therapeutic significant difference in reduction of Mathematics anxiety of students and in terms of gender, no score differential. It was recommended that workshops/Seminars on psychological techniques on examination anxiety be organized for mathematics teachers.

INTRODUCTION

Sometimes Students do not do well in examinations not because they are not intelligent but because some extraneous factors like anxiety interfered with their academic functioning and level of achievement.

According to Frennd (1949), Anxiety is "something felt" a specific unpleasant emotional state or condition of human organism. It is also a state of emotional and physical disturbance induced in a person by a real or imagined threat. Anxiety manifests itself differently from other emotions in terms of gestures, posturing performance of interpersonal and also quality of voice. It becomes more dangerous when it is encountered by students during examinations. It causes some students to experience some physiological reactions during examination such as increased heart rate, cold hands, frequent urination, dried mouth, muscle spasm, increase respiration (Zeidner, 1998). These are manifested when taking Mathematics examination. Examination anxiety is dangerous to the growth of an educational system because it brings about poor academic performances of students and this accelerates into decline in educational growth (Ossai, 2004) He also reported a significant correlation between students examination anxiety and their examination malpractice attitude.

Mathematics is one of the compulsory school subjects in Nigeria at both primary and secondary levels. It is very important in arts, social sciences and science subjects. It is widely applied in professional fields such as medicine, pharmacy, engineering, architecture, law, accounting etc. (Onwuka and Kolo, 2010).

However, it is a subject that is dreaded by many students. To many, it is an abstract subject meant for very few. This makes many students to have mathematics phobia and experience anxiety when they hear the name "Mathematics". To Onwuka (2012), Mathematics Phobia is a persistent fear towards the study of mathematics which leads student to avoid mathematics.

With these problems associated with mathematics anxiety, it becomes necessary to seek ways/means that can help ameliorate this ugly phenomenon. In this regard, the relevance of some psychological counseling therapies cannot be overemphasized; and Systematic Desensitization (SD), cognitive behavioural therapy (CBT), psychoanalysis, rational emotive behaviour therapy (REBT), easily come to mind.

Cognitive Behavioural Therapy (CBT) is a psychotherapy based on cognitions, assumptions, beliefs and behaviours, which aims at influencing disturbed emotions that relate to inaccurate appraisal of events (Lin, 2008). CBT has been widely used to treat various kinds of maladaptive disorders including mood and examination anxiety disorders. Since it is based on changing the students' erroneous ways of thinking about themselves, the world and how others perceive them, it can be applied to curb the problem of mathematics

anxiety. CBT increases a sense of control and thereafter helps the student adhere to behaviour change strategy as well as improving mood and inducing associated psycho-pathology (Kenger, 2006).

STATEMENT OF PROBLEMS

Mathematics is a school subject that is very important in everyday living. It is applied in sciences, technical and non technical areas. Mathematics examination anxiety is dangerous to the academic growth and development of any nation. It is associated with some negative phenomenon such as physiological reactions (worry, fear) and examination anxiety. Cognitive Behaviour Therapy is one of the psychological therapies that has been successfully applied increase such as health, education and can equally be tried in mathematics in Nigeria. The problem of this study therefore is: What is the effect of cognitive Behaviour therapy on anxious mathematics students?

RESEARCH QUESTIONS

1. To what extent does cognitive behaviour therapy reduce examination anxiety in mathematics?
2. To what extent does cognitive behaviour therapy reduce mathematics anxiety in male and female students ?

RESEARCH HYPOTHESES

The following null hypotheses guided the study and was test at .05 level of significance.

Ho₁ There is no significant difference between the pre-test and post-test scores of mathematics students treated with cognitive Behaviour Therapy.

Ho₂ There is no significant difference in the reduction of mathematics examination anxiety in male and female students using cognitive Behaviour therapy.

PURPOSE OF STUDIES

The main purpose of the study is to investigate the effectiveness of cognitive Behaviour Therapy (CBT) in the treatment of students examination anxiety in mathematics.

METHOD

The researcher adopted a quasi-experiential design. It investigated the possible cause and effect relationship by exposing one treatment group and one control group (not exposed to treatment) . The population comprised all the senior secondary school-two students in Ika south Local Government Area of Delta State in Nigeria. A total 2025 were involved consisting 1038 male and 987 female students.

In composing the sample, first purposive sampling technique was employed to eliminate, the schools that are not co-educational, This is as a result of gender analysis. At the second stage, Six schools were selected to form the sample with a sample size of 68 students, made up of 33 males and 35 females.

The research instrument, was mathematics Anxiety Test scale (MATS) modified from Sarason Test Anxiety Scale which contained 37 items. All the students were tested. The result of the pre-test enabled the researchers to identify those that have anxiety and they were accordingly assigned to experimental and control groups.

To establish the reliability of MATS, Combach Alpha reliability method was used and an index of 0.83 was obtained which showed an evidence of internal and external consisting of the instrument, Those who scored between 24 and 37 are those who showed symptoms of anxiety. They were exposed to seven weeks treatment. At the end of the seven weeks training, they were given the same MATS again in order to ascertain the effectiveness of the training. Mean and standard Deviation (SD) were used in answering the research questions while the null hypotheses were tested using t-test, Analysis of covariance (ANCOVA) at 0.05 level of significance.

Research Questions 1:

To what extent does cognitive behaviour therapy reduce examination anxiety in Mathematics?

Table 1; Reduction of Examination Anxiety in Mathematics

CBT	Pre-Test Scores	Post Test Score
Means (x)	28.59	16.38
S.D.	2.34	6.95
N	68	68

Table 1 above addressed the research question, There was a reduction in the means score of mathematics anxiety of the students treated with cognitive therapy from 28.59+2.34 of the pre- test scores to 16.38 + 6.95 of the post-test.

The mean difference is 12.21.

Research Question 2:

To what extents does cognitive behavior therapy reduce mathematics anxiety in male and female students?

Table 2: Mathematics Examination anxiety in Male and female students.

Gender		Pretest scores	Post test scores	Means difference
Male	N	33	33	
	X	27.88	17.03	10.85
	S.D	2.16	5.80	
Female	N	35	35	
	X	29.26	15.77	13.49
	S.D	2.33	7.93	

The mean value for the male students reduced from 27.88 before treatment to 17.03 after treatment while for the female students, it reduced from 29.26 to 15.77. The mean difference is therefore 10.85 and 13.49 for male and female students respectively.

Hypothesis 1: There is no significant difference between the pretest and post-test scores of mathematics students treated with cognitive behaviour therapy. The result of the test is present in table 3.

Table 3: Paired sampled t-test of post-test and pre-test of scores mathematics student treated with CBT

	Faired differences			95% confidence	T	df	Sig	Remark	
	X	S.D	S.E.M						
Pretest & post-test scores	12.21	7.18	0.87	10.47	13.95	14.01	67	0.00	Significant

Table 3 shows that there was a significant difference between pretest and post-test scores of mathematics students treated with cognitive behaviour therapy, with mean difference of 12.21 with 95% confidence interval ranging from 10.47 to 13.95, t-value is 4.01. The null hypothesis is therefore rejected.

Hypothesis 2: There is no significant difference in the reduction of mathematics examination anxiety in male and female students using cognitive Behaviour therapy. Test result is given in table 4.

Table 4: ANCOVA Of Mathematics Examination Anxiety in male and female students using CBT

Source	Types sum of square	df	Means square	F	Sig	Partial square	Remark
Correct mode	59.39	2	29.70	0.61	0.55	0.02	
Intercept	22.87	1	22.87	0.47	0.50	0.01	
Pretest	32.48	1	32.48	0.66	0.42	0.01	
Gender	44.16	1	44.16	0.90	0.35	0.01	
Error	3180.67	65	48.93				
Total	21490.00	68					
Correct total	3240.06	67					Not significant

From Table 4, $F(1,65) = 0.90$, $P = 0.35$. The effect size which is very low is 0.01 representing only 1% variance. Comparing the pre-test and post-test scores of male and female mathematics students, it was not significant as show by the P value of 0.42 ($f(1, 65) = 0.66$). Hence there is no significant difference in the reduction of mathematics examination anxiety in male and female students. Hence the null hypotheses is accepted.

DISCUSSION

The result of the experiment shows that there is a significant difference between the pre-test and post-test scores of mathematics students treated with cognitive behaviour Therapy (CBT). In Otherwords CBT was effective in the treatment of mathematics anxiety among secondary school students. The difference is really reflected in the pre-test and post-test mean scores of 28.59 and 16.38 respectively. The mean scores reduction of 12.21 after treatment indicates an evidence of an effective treatment. It showed that students who were treated with CBT had their anxiety level reduced after treatment. The result is in consonance with the study conducted by (Salami 2007). He examianed the effectiveness of CBT in managing stress among some trainees of college of education in kwara state, Nigeria. The result indicated that the participants had significant reductions in levels of stress,

depression and anxiety. The study conducted by Omotosho, Titiloye and Titiloye (2013) is also in line with the above result. Their work centred on reduction of mathophobic level among in-school adolescents in Nigeria using Rational Emotive Behaviour – Therapy (REBT). The result showed significant reductions in mathophobic levels on those treated with REBT.

The findings on gender difference on Mathematics students examination anxiety reveals no significant difference in the reduction of examinations anxiety in male and female students. Hence gender had no influence on students post-test scores.

CONCLUSION/RECOMMENDATIONS

The study investigated the effectiveness of cognitive behaviour. Therapy (CBT) in the treatment of mathematics anxiety among secondary school students in Nigeria. From this study we can conclude that CBT is effective in the treatment of mathematics examination anxiety among secondary school students. Additionally, there is no gender influence in the reduction of examination anxiety.

Based on the conclusion reached we therefore recommend that

- (i). Mathematics teachers should be trained on therapeutic techniques of reduction of mathematics examination anxieties. This can be done by organising seminars and workshops.
- (ii). Text Books on such therapeutic techniques should be in circulation.
- (iii). Students should cultivate good reading habit. Through reading situations that can lead to high anxiety level could be averted.

REFERENCE

- Frend, S. (1949) An outline of psychoanalysis: New York: Norton.
- Lin,T (2008) Cognitive Behaviour Therapy <http://en.wikipedia.org/wik./> cognitive behaviour therapy (retrieved 10/6/2008)
- Omotosho; J.A. Titiloye, R.O.& Titiloye, E.O. Reductions in Mathophobic levels among in-school adolescent in Ilorin, Nigeria, using rational emotive behaviour therapy. ABACUS . THE Journal of Mathematical Association of Nigeria 38(1),103-110
- Onwuka P.I(2012) Eradicating Mathematics Phobia among the girls in Nigeria primary schools. International Journal of forum of African women educationalist...1(4), 98 – 105
- Onwuka, P.I & Koko, G.M. (2010) The use of ICT in the teaching of mathematics in colleges of education in Nigeria. Journal of Issues of Mathematics of science teachers Association of Nigeria (STAN), 13,74-80
- Ossai, M.C. (2004) Study habit and examination Anxiety as correlates of students attitude towards examination malpractices in tertiary institution in Delta State. An unpublished Ph.D Thesis, Delta State University, Abraka.
- Salami, S.O. (2007). Management of stress among training teachers through cognitive Behaviour Therapy. Pakistan Journal of Social Science, 2,229-307
- Zeidner, M (1998) Test Anxiety. The state of art, New York: Phenom press.

EFFECTS CONSTRUCTIVIST BASED INSTRUCTIONAL STRATEGY ON STUDENTS' LEARNING OUTCOME IN MATHEMATICS

DR. MRS. Philomina .I. ONWUKA
MATHEMATICS DEPARTMENT, COLLEGE OF EDUCATION, AGBOR, NIGERIA.
philonwuka@yahoo.com +2348035783701

Keywords: Mathematics, Constructivist, Instructional strategy.

ABSTRACT: This paper examines the impact of constructivist –Based instructional strategy on students' achievement in Mathematics. The study employed a quas:- experimental design carried out in Delta State, Nigeria. The researcher generated one research question and one hypothesis which were answered/tested with mean, standard deviation and t-test respectively. A sample of 215 was composed with 104 assigned to experimental and 111 control group. The instrument for the study was Mathematics Achievement Test (MAT). The reliability coefficient of 0.81 was established using Crombach's Alpha method. The result of the experiment indicates that those in experimental group performed significantly better. It was recommended that Mathematics teachers should be retrained in modern instructional strategies such as constructivist Based Instructional Approach.

INTRODUCTION

Mathematics is one of the subjects that is offered in school systems in Nigeria. It is a core subject at the primary and secondary educational levels. It is a basic tool for all scientific and technical know-how, and it plays an important role in the economic development of any nation (Ogbonna, 2007). In fact, according to Moseri, Onwuka, Iweka (2010), mathematics is very important in everyday living and it is maximally utilized in science and non-science subjects.

In spite of the important role mathematics plays in the development of any nation, its performance in the primary and secondary schools in Nigeria is poor. The table below, shows the students' result in the senior secondary school organized by the West African Examination Council (WAEC), from 2000 to 2009

Table 1; Result Of Senior Secondary School Mathematics By WAEC, From 2000 To 2009

Years	% with credit and above	% with pass and below
2000	32.81	67.19
2001	36.55	63.45
2002	34.50	65.50
2003	36.91	63.09
2004	34.52	65.42
2005	35.55	64.45
2006	39.92	60.08
2007	15.56	84.44
2008	23.00	77.00
2009	31.00	69.00

From the table, it is obvious that the performance of Mathematics at the secondary school level is poor. The story is not different from other educational levels. Educationists and researchers have adduced different reasons for this ugly phenomenon (poor performance). Galadinma (1998) and Ojo (1998) in their findings linked the poor performance to poor quality of instructional techniques employed by teachers as the major cause of while Bello (2006) and Adamu (2007) identified the root causes to be: i. overcrowded nature of the classes, ii. Teacher's poor method of teaching.

From the foregoing, there is need therefore to explore means of teaching that can bring a better understanding which can improve performance. Steen (2003) advocates that teachers can stimulate students to learn Mathematics through the process of constructing patterns in addition to devising strategies for solving problems and discovering the application and beauty of Mathematics. The above method is in consonance with constructivist teaching view.

Constructivist perspective holds the view that it is about knowing and learning that emphasizes the active role of learners in constructing their own knowledge (Von Glaserfeld, 1989). It suggests that learners construct knowledge out of experience; knowledge is constructed in trying to integrate existing knowledge and new experiences (Moseri, et al).

Brooks and Brooks (1993) enumerated five important principles of constructivist pedagogy which include:

1. Proposing problems of emerging relevance.
2. Constructing learning around primary concepts
3. Seeking and valuing students points of view.
4. Assessing student's learning.
5. Adapting curriculum to address students suppositions.

When these principles are applied in the Mathematics teaching, it could ameliorate the problem of poor achievements in the secondary schools. Against this background there is need to dry the instructional strategy (constructivist)

STATEMENT OF PROBLEM

Mathematics as an important and compulsory subject at the primary and secondary school levels in Nigeria, is maximally utilized in science, technical and almost all sphere of life. In spite of its utility, the achievement is very poor at these educational levels. Educationists and researchers have been worried and concerned on how this poor mathematics performance can be remedied.

Constructivist Based-Instructional strategy is a relatively new approach to teaching and has been effective in some countries. It can equally be effective in Nigeria, particularly in Delta State. Hence, what is the impact of constructivist based- instructional approach on student's achievement in mathematics?

PURPOSE OF STUDY

The purpose of this study is to determine if there is difference in the performance of students taught mathematics using constructivist strategy and those taught using conventional learning strategy.

RESEARCH QUESTION

What is the difference in the mean achievement score of students taught mathematics using constructivist-based learning strategy and those taught and those taught using conventional method?

HYPOTHESIS

The hypothesis below was formulated to guide the study and tested at point 05 level of significance.
 Ho: There is no significant difference in the mean achievement scores of students taught mathematics using constructivist- based instructional approach and those taught using conventional learning strategy.

METHODOLOGY

The study employed a quasi- experimental design of non-equivalent post-test, control group design. Intact classes were used, to avoid disrupting the normal school programmes for experimental purpose. The study was restricted to senior secondary school one (SSS 1) students and the topic taught was geometry. The area of study was Ika South local government Area of Delta State of Nigeria. Three schools out of the 18 senior secondary schools in Ika South local Government Area were randomly composed for the study and this gave rise to a sample of 215 students.

The experiment was for a duration of four weeks and the students in the three schools were taught the same topics. In each school, there were two classes; one for experimental and the other, control. The experimental groups were students taught mathematics with constructivist based- instructional strategy, while the control group were those taught with conventional instructional strategy. 104 students were in the experimental groups while 111 were in control groups.

The instrument for the research was Mathematics Achievement Test (MAT) which was administered at the end of the treatment. MAT contains ten essay items. The research question was answered with mean while the hypothesis was tested with statistical tool, t-test, at 0.05 level of significance.

RESULTS

Research Questions:

What is the difference in the mean scores of the students taught mathematics using constructivist-based learning strategy and those taught using conventional method?

The answer to this question is presented in table 2

Table 2: Mean And Standard Deviation (SD) Of Constructivist And Conventional Methods.

Group	Mean	SD	N	Mean difference
Constructivist	31.30	8.19	104	7.88
Conventional	23.42	5.80	111	

From the table 2, the mean score of students taught mathematics with constructivist approach is 31.30 and those taught with conventional method is 23.42. their standard deviations are 8.19 and 5.80 for constructivist approach and conventional method respectively. The difference in their means is 7.88 which appears high.

Hypothesis

There is no significant difference in the mean achievement scores of students taught mathematics using constructivist- based instructional strategy and those taught using conventional method.

The test of the hypothesis is presented in table 3

Table 3:t-Test Showing Students' Achievement In Mathematics Using Conventional Method.

Group	Mean	SD	N	Df	Calculated	Sig.
Constructivist	31.30	8.19	104	213	14.85	0.00
Conventional	23.42	5.80	111			

From the table, the level of significant (0.00) is less than the set .05 hence, there is a significant difference in the students' performance. The implication is to reject the null hypothesis of no- significant difference.

DISCUSSION

The mean score of students taught with constructivist- based learning strategy is 31.30 while the students taught using conventional method had a mean score of 23.42. When this was tested statistically using t-test, the difference in their means was significant. This led to the rejection of the null hypothesis and upholding of the alternative hypothesis. This implies when students are taught with constructivist instructional approach, it can produce a better result compared to the conventional method.

These findings, agree with the findings of previous researches such as (Alio, 1997 and Ogbonna, 2007). In their studies, the experimental group performed better than the non-experimental group. This affirms that appropriate instructional materials yields a better performance.

CONCLUSION/RECOMMENDATION

The study looked into the impact of constructivist learning strategy on secondary school students' performance in Nigeria. The result of the study indicates a significant difference in the two teaching approaches employed in favour of constructivist learning strategy. It can be deduced therefore that constructivist learning strategy is effective in the teaching of mathematics.

Based on the above, the following recommendations are made;

- (i) Constructivist- Based learning strategy should be incorporated in the mathematics curriculum for the pre-service teachers' programme.
- (ii) Workshops should be organized for the in-service mathematics teachers to enable them learn constructivist approach.
- (iii) Authors and publishers of mathematics textbooks should incorporate the approach into their books with worked examples.
- (iv) Ministries of Education (Federal, State, Local Government) Education boards, professional bodies such as Mathematical Association of Nigeria (MAN), Science Teachers Association of Nigeria (STAN) should all endeavor to promote this new approach.

REFERENCES

- Adamu, N.A. (2007). State of Learning Science and Mathematics in Kastina State secondary schools. A report submitted to the Department of research and statistics Kastina State Ministry of Education.
- Alio B.C. (1997) Polya's problem solving strategy in secondary school students' achievement and interest in mathematics. An unpublished PhD Thesis University of Nigeria, Nsukka.
- Bello H.M. (2006). Analysis of some secondary school students' achievement in mathematics in two North-Western states in Nigeria. A report submitted to Kastina State Ministry of Education.
- Brooks M.G & Brooks J.G. (1987). "Becoming a teacher for thinking. Constructivism chance and consequences." The journal of staff development, 8(3), 16-20
- Brooks J.G & Brooks M.G. (1993). In search of understanding. The case for constructivist classrooms. Alexandra V.A.; Association for the supervision and curriculum Development.

Galadinma I. (1998). Some aspects of students' problem solving difficulties in secondary school mathematics. *The pioneer: A multi-disciplinary Journal of education*, Amadu Bello, University, Zaria 2(2), 1-9

Moseri, P.O.; Onwuka P.I. & Iweka S. (2010). Constructivism; A tool for the attainment of seven point agenda. A paper presented at the 47th Annual Conference of the Mathematical Association of Nigeria, (MAN), 8-12

Ogbonna C.C. (2007). Effects of two constructivist instructional models on students' achievement and retention in Number and Numeration. An unpublished PhD Thesis, University of Nigeria, Nsukka.

Ojo M.O. (1998). Maximizing students' learning of mathematics through students' interaction patterns. A paper presented at the 35th Annual Conference of Mathematical Association of Nigeria, (MAN)

Steen L.A. (2003). Out from under achievement issue in Science and Technology. Retrieved on February 13, 2006 from <http://www.issue.org.119.4.update/steen.html>

Von Glaser field, E.(1989). Construction of knowledge, and teaching synthesis 89, 121-140

ARAŞTIRMAYA DAYALI FEN LABORATUARI UYGULAMALARININ ÖĞRETMEN ADAYLARININ YARATICI DÜŞÜNME DÜZEYLERİNE ETKİSİ

THE EFFECT OF INQUIRY BASED SCIENCE LABORATORY ACTIVITIES ON PRESERVICE SCIENCE AND TECHNOLOGY TEACHERS' CREATIVE THINKING LEVELS

Hatice BAYKARA
Pamukkale Üniversitesi Eğitim Bilimleri Enstitüsü İlköğretim A.B.D.
hbaykara@pau.edu.tr

Yrd. Doç. Dr. Zeha YAKAR
Pamukkale Üniversitesi Eğitim Bilimleri Enstitüsü İlköğretim A.B.D.
zyakar@pau.edu.tr

ÖZET: Bu çalışmada Fen Laboratuvar Uygulaması dersinde uygulanan araştırmaya dayalı öğrenme uygulamalarının öğretmen adaylarının yaratıcı düşünme düzeylerine etkisi araştırılmıştır. Araştırmanın örneklemini Pamukkale Üniversitesi Eğitim Fakültesi ilköğretim fen bilgisi öğretmenliğinde okuyan 36 öğretmen adayı oluşturmuştur. Bu araştırmada veriler Torrance Yaratıcı Düşünme Testi (TYDT) ile toplanmıştır. Araştırmaya dayalı laboratuvar uygulamaları ile öğretmen adaylarının yaratıcı düşünme düzeylerindeki gelişim TYDT'de yer alan akıcılık, esneklik ve özgünlük düzeylerinde incelenmiştir. Veriler, SPSS 15 paket programı ile amaca uygun olarak aritmetik ortalama, standart sapma ve T testi değerlerine göre analiz edilmiştir. Verilerin analizi sonucunda öğretmen adaylarına uygulanan araştırmaya dayalı laboratuvar uygulamalarının yaratıcı düşüncelerini geliştirmede etkili olduğu görülmüştür. Ayrıca bu çalışmanın sonuçlarına göre öğretmen adaylarının araştırmaya dayalı laboratuvar uygulamaları ile yaratıcı düşünme boyutlarından olan özgünlük boyutunda en çok gelişme gösterdikleri ortaya konmuştur.

ELEKTRİK AKIMI VE İLGİLİ KONULARA AİT ÖĞRETME DURUMLARININ PRAKSEOLOJİK ANALİZİ

PRAXEOLOGICAL ANALYSIS OF THE TEACHING CONDITIONS OF THE ELECTRIC CURRENT

Ümmü Gülsüm DURUKAN
Giresun Üniversitesi, Eğitim Fakültesi
ummugulsum.durukan@giresun.edu.tr

Ayşegül SAĞLAM-ARSLAN
Karadeniz Teknik Üniversitesi, Fatih Eğitim Fakültesi
asaglam-arслан@ktu.edu.tr

ÖZET: Chevallard (1998)'ın ortaya attığı Didaktiğin Antropolojik Kuramı içerisinde yer alan prakseolojik yaklaşım bilimsel bilginin yapısını sorgulamaya ve analiz etmeye fırsat tanımaktadır. Bu yaklaşım, gerçekleştirilen bir eylem kapsamında araç-amaç ilişkilerini dikkate alarak ders kitaplarında veya sınıf içerisinde oluşturulan veya oluşturulmak istenen bilimsel bir bilginin betimlenip tartışılmasına olanak sağlamaktadır (Chevallard, 2006). Ders kitaplarının prakseolojik yaklaşım ile analiz edilmesi, uygulamaların, problem türlerinin, problem çözüm stratejilerinin belirlenmesine yardımcı olmakta ve böylelikle diğer çözümlerde (özellikle öğrenci çözümlerinin de) referans çözüm ile kıyaslayarak analiz edilebilmektedir. Ayrıca, öğrenme süreçlerinde formüllere odaklanılması, öğrencileri formülleri ezberletmeye yöneltmektedir (Kurnaz & Sağlam-Arslan, 2010) ve bu tür öğrenme ortamlarının öğrencilerin yüzeysel öğrenmeler gerçekleştirmesine sebep olduğuna inanılmaktadır (Kurnaz & Sağlam-Arslan, 2009). Bu bağlamda, çalışmanın amacı üniversite eğitimi sırasında Fizik alanında ağırlıklı olarak takip edilen ve kaynak kitap olarak kullanılan yedi kitapta yer alan elektrik akımı ve ilgili konulara ait öğretme durumlarını prakseolojik yaklaşımdan yararlanarak analiz etmektir. Kitapların analizi sonucunda, öğrenenlerden yapılması istenen aktivite durumları belirlenmiş ve sınıflandırılmıştır. Genellikle hesaplama ve açıklama aktivitelerinin, belirlenen aktivite durumları arasında ağırlık kazandığı görülmektedir. Öğretme durumlarının öğrencilerin öğrenme durumları üzerindeki etkileri göz önüne alınarak kaynak kitaplardaki aktivitelerin hesaplama ve açıklama aktiviteleri ile sınırlandırılmaması ve daha üst düzey becerileri gerektiren (analiz, sentez, değerlendirme gibi) aktivitelere yer verilmesi önerilmektedir. Bu doğrultuda, prakseolojik analiz yaklaşımı kullanılarak öğrenme-öğretme durumları ve arasındaki ilişkilerin analiz edilmesi ile öğrenme ortamlarının eksikliklerinin giderilmesi ve bu ortamların zenginleştirilmesi de sağlanabilir.

Anahtar Sözcükler: Elektrik akımı, Prakseolojik analiz yaklaşımı, Öğretme durumları

ABSTRACT: In the Anthropological Theory of Didactics, which was introduced by Chevallard (1998), the praxeological analysis approach gives opportunity to analyze and question the nature of scientific knowledge. This approach allows to discuss the scientific knowledge which is created or will be formed in the textbooks or classroom by taking into account the means-end relationships within the scope of an action performed (Chevallard, 2006). Analyzing the textbooks via the praxeological analysis helps to determine the practices, the types of problems and problem solving strategies. In this way, the other solutions (especially students' solutions) can be analyzed by compared with the reference solution. In addition, focusing on the formulas in the learning process has been forced the students memorizing these formulas (Kurnaz & Sağlam-Arslan, 2010) and it is believed that this type of learning environments cause superficial learning for students (Kurnaz & Sağlam-Arslan, 2009). In this context, the purpose of the study is to analyze the teaching conditions of the electric current in the seven textbooks that following and using as the source book the during university education by using the praxeological analysis approach. As a result of the textbooks' analysis, the activity situations are identified and classified. It is seen that the calculation and the description activities are generally used in the all activity types. By taking into consideration the teaching conditions' effects on the students' learning conditions, it is recommended that the activities in the source books wouldn't be limited with only the activities of calculation and description and the activities required using the higher-level skills (analysis, synthesis, evaluation, etc.) should be included. In this respect, overcoming the deficiencies of the learning environments and enrichment of these environments are provided by analyzing the teaching-learning conditions and the relations between them with praxeological analysis approach.

Key words: Electric current, Praxeological analysis approach, Teaching conditions.

CONCEPT CARTOON SAMPLES INTEGRATED INTO PROBLEM BASED LEARNING IN SCIENCE COURSES*

Ali Günay BALIM

Department of Science and Technology Education, Dokuz Eylül University,
Buca Faculty of Education (Turkey)
agbalim@gmail.com

Sevinç KAÇAR

Department of Science and Technology Education, Dokuz Eylül University,
Institute of Educational Sciences(Turkey)
kacarsevinc@gmail.com

Erkan ÖZCAN

Department of Science and Technology Education, Dokuz Eylül University,
Buca Faculty of Education (Turkey)
erkanozcan88@gmail.com

Ümmühan ORMANCI

Department of Science and Technology Education, Uludağ University,
Faculty of Education (Turkey)
ummuhan45@gmail.com

ABSTRACT: It is expected that science education will enable students to question, think analytically and creatively, make effective decisions and be scientifically literate individuals. This will only be possible through the use of teaching methods that allow the active participation of students in the learning process. One of these methods is the problem-based learning in which real life issues are presented as scenarios. Problem-based learning can be supported by the use of other techniques in order to increase students' interest, identify their misconceptions and overcome them. One of the techniques to be used is concept cartoons which can make the scenarios used in problem-based learning more understandable and meaningful. The present study aims to explain the use of concept cartoons integrated into problem-based learning in science education, and to present sample activities. For this purpose, concept cartoon activities prepared in relation to 6th grade science units "Substance and Heat" and "Heat Insulation" are presented. These activities include scenarios and concept cartoons that deal with everyday problems. To sum up, the use of concept cartoons integrated into problem-based learning is explained through sample activities.

Key words: Science Courses, Problem Based Learning, Concept Cartoons

EFFECTS OF PROBLEM BASED LEARNING ON PROSPECTIVE SCIENCE TEACHERS' ATTITUDES TOWARDS BIOLOGY LABORATORY

Ali Gunay BALİM

Erkan OZCAN

This study's aim was to research effects of problem based learning on prospective teachers' attitudes towards biology laboratory. Experimental practice was made with science prospective teachers who were studying second grade in Dokuz Eylul University Buca Faculty of Education. This study was conducted with pre test post test quasi experimental research design. Courses of experiment group continued with problem based learning while courses of control group continued with general biology laboratory instruction program.

Attitude Scale Towards Biology Laboratory applied on prospective teachers in experiment and control groups. Analysis of obtained data made with SPSS program. After data analysis, a significant difference found in attitudes towards biology laboratory between experiment

and control group in favor of experiment group. It's thought that this study will lead to new researches and will help determining effects of problem based learning on prospective teachers.

Keywords: Problem based learning, attitude towards biology laboratory, prospective science teacher.

GÜNEY KORE VE TÜRKİYE'DEKİ ÖĞRENCİLERİN MATEMATİK BAŞARILARI İLE AİLE İŞLEVSELLİĞİ ALGILARININ İLİŞKİSİ

THE RELATIONSHIP BETWEEN THE STUDENTS' MATHEMATICS SUCCESS AND FAMILY FUNCTIONING PERCEPTION IN SOUTH KOREA AND TURKEY

M.Kerem KARAAĞAÇ
Marmara Üniversitesi
kerem.karaagac@marmara.edu.tr

Hatice Nur ERBAY
İstanbul Üniversitesi
hatice.nur.erbay@gmail.com

ÖZET: Araştırmanın amacı öğrencilerin aile işlevselliği algısı ile matematik başarıları arasında bir ilişki olup olmadığını, varsa bu ilişkinin Güney Kore ve Türkiye için farklılık gösterip göstermediğini incelemektir. Türkiye verilerini İstanbul'daki 13-14 yaş grubu öğrenciler yani 7. ve 8.sınıf öğrencilerinden 319 öğrenci oluşturmaktadır. Güney Kore verilerini ise Seul'deki 13-14 yaş arasındaki öğrenciler yani ortaokulların 1. ve 2.sınıf öğrencilerinden 298 öğrenci oluşturmaktadır. Veri toplama araçları olarak "Matematik Başarı Testi" (Çanakçı, 2008) ve "Aile Değerlendirme Ölçeği" (Bulut, 1990) kullanılmıştır. Çalışmada Aile Değerlendirme Ölçeğinin alt boyutlarından "Genel İşlevler" alt boyutuna ait veriler sunulmuştur. Analizler Türkiye ve Güney Kore verileri için ayrı ayrı yapılmıştır. Hem Türkiye hem Güney Kore verilerinde aile işlevselliğinin alt boyutlarından "Genel İşlevler" ile matematik başarıları arasında pozitif yönde bir korelasyon bulunmuştur. Ayrıca ki-kare testi öğrencilerin ailelerini sağlıklı veya sağlıklı algılamaları ile matematik başarıları arasında anlamlı bir ilişki olduğunu göstermiştir.

Anahtar Sözcükler: matematik başarıları, aile işlevselliği, fonksiyonel aile

ABSTRACT: The purpose of the research is to determine the relationship between the students' family functioning perception and mathematics success and it is inquired whether this relationship differentiates between South Korea and Turkey. The sample of the study consists 319 students from 7th and 8th grades (ages 13-14) of state schools in Istanbul and 298 students from 1st and 2nd grades of secondary schools (ages 13-14) in Seoul. The questionnaire which is developed by Çanakçı, (2008) is used to collect information about mathematic success level of the students. Family Evaluation Scale developed by Bulut, (1990) is used to determine the family functioning, as a data collection instrument. In this paper data from 'General Functions' subscale of Family Evaluation Scale is presented. The data analysis of Turkey and South Korea are has been carried out separately. The results of this study indicated that there is a significant and positive relationship found between mathematic success and the perceptions of students about their family (whether healthy or unhealthy) in terms of family functioning.

Key words: mathematics success, family functioning, functional family

GİRİŞ

Matematik, öğrencilerin büyük bir çoğunluğu için zor bir ders olarak görülmektedir. Bu durum, öğrencilerin matematikten korkmasına ve uzaklaşmasına neden olabilmektedir. Matematiğin öğrencilerin çoğunluğu tarafından korkulan bir ders olarak görülmesinin altında sadece bir faktörün etkin olduğunu söylemek zordur. Çünkü, öğrencilerin matematik başarılarını veya başarısızlığını etkileyen bir çok faktör vardır. Ailenin bu konuda oldukça etkili olduğu düşünülmektedir. Burada genellikle ailenin sosyo-ekonomik durumu kastedilmektedir (Dursun ve Dede,2004; Yenilmez ve Duman,2008). Ailenin akademik başarıyı dolayısıyla matematik başarılarını etkilediği kabul edilmektedir. Ebeveynlerin çocuklarının okul aktiviteleri ve akademik başarılarına etkisi eğitim araştırmalarında uzun bir tarihe sahiptir (Mandara,2006). İlk çalışmalar aile katılımının özellikle ilköğretim çağındaki öğrencilerin akademik başarıyla pozitif bir ilişkisi olduğunu göstermiştir (Reynolds,1992 Akt. Mandara,2006). Son çalışmalar ise ailenin çocuklarının matematik ve fen notları, zihinsel düşünme becerisi, iş ahlakı ve sosyal gelişimi gibi pek çok konuda önemli etkiye sahip olduğunu göstermiştir (Marcon,1999 Akt. Mandara,2006). Acaba bu etki ailenin sosyo-ekonomik durumundan ibaret midir? Öğrencilerin ailelerinin işlevselliği matematik başarılarını etkilemekte midir? Ailenin matematik başarılarına etkisi ele alınırken aile

işlevselliğinin ihmal edilmesi, bu konuda herhangi bir çalışmanın bulunmaması böyle bir inceleme yapma gerekliliğini ortaya koymuştur.

Aile işlevselliği, aile üyeleri arasındaki ilişkinin pek çok yönünü içeren (problem çözme, iletişim, roller, duygusal tepki verme, gereken ilgiyi gösterme, davranış kontrolü ve genel işlevler) ve bunlara göre fonksiyonel (sağlıklı) ve fonksiyonel olmayan ailelerin belirlenmesini sağlayan bir kavramdır. Sorunlarını bir araya gelerek çözebilen, birbirine duygusal olarak bağlı ve özgürlüklerini önlemeyecek şekilde ilgili, herkesin kendisinden beklenen rolü etkili bir biçimde yerine getirebildiği, birbirlerinin davranışlarını aşırıya kaçmayacak şekilde kontrol edebilen ve aralarında açık, rahat ve dolaysız bir iletişim bulunan aileler, işlevlerini yerine getirebilen sağlıklı veya fonksiyonel aileler olarak tanımlanmaktadır (Bulut, 1990).

Günümüzde eğitim uluslar arası bir nitelik kazanmıştır. Eğitim sorunlarındaki benzerlikler nedeniyle alınan önlemler kadar, uygulanan yöntemlerde de benzerlikler olması beklenmektedir. Bu yüzden karşılaştırmalı eğitim araştırmaları, eğitimin uluslar arası yönlerini inceleyerek eğitim sistemlerine çözüm bulmada yardımcı olabilir (Cho, 1997). Çalışmada Güney Kore'nin seçilmesinde hem Güney Kore'nin TIMSS'teki başarısı (Yücel ve ark.,2013; TIMSS Raporları) hem de Güney Kore'de Türkiye'nin "kardeş ülke" olarak görülmesi etkili olmuştur.

YÖNTEM

Bu çalışma Türkiye'de İstanbul ile Güney Kore'de Seul illerindeki 13-14 yaş grubundaki öğrencilerin, matematik başarıları ile aile işlevselliği arasındaki ilişkiyi belirlemek amacıyla gerçekleştirilmiş olan karşılaştırma türü ilişkisel tarama modelinde, betimsel bir araştırmadır. Araştırmanın evrenini Türkiye'de İstanbul ilindeki 13-14 yaş grubu öğrenciler ile Güney Kore'de Seul ilindeki 13-14 yaş grubu öğrenciler oluşturmaktadır. Araştırmanın örneklemini ise İstanbul'dan bu yaş grubundan yani 7. ve 8. sınıf öğrencilerinden 319 öğrenci ile Seul'den 298 öğrenci oluşturmaktadır. Araştırmada veri toplama araçları olarak "Matematik Başarı Testi" (Çanakçı,2008) ve "Aile Değerlendirme Ölçeği" (Bulut,1990) kullanılmıştır.

Matematik Başarı Testi

"Matematik Başarı Testi (MBT)", Çanakçı (2008) tarafından uluslar arası çalışmalar esas alınarak hazırlanmış, geçerliliği ve güvenilirliği hesaplanmıştır. 25 maddenin her birinin varyansına bağlı Cronbach Alfa değeri 0,813 ve testin iki eş parçaya ayrılması ile Spearman-Brown ve Guttman iç tutarlılık katsayıları 0,769 ve 0,767 olarak hesaplanmıştır. Matematik Başarı Testi için test-tekrar test yöntemi kullanılarak ilk uygulama yapıldıktan 4 hafta sonra daha önce başarı testini cevaplayan 7. ve 8. Sınıf öğrencilerinden 73'üne başarı testi tekrar uygulanmıştır. Matematik Başarı Testinin zamana göre değişmezliğinin sınanmasına ilişkin olarak yapılan bağımlı grup t-testi sonucunda öğrencilerin test puanlarının ortalamalarının iki uygulama sonucunda 0,05 düzeyinde anlamlı bir farklılık göstermediği söylenebilir. ($t=0,489$, $p>0,05$) Ayrıca hesaplanan Pearson Momentler Çarpımı Korelasyon Katsayısı ($r=0,884$; $p=0,000$) iki uygulama sonucunda elde edilen test puanları arasındaki ilişkinin yüksek derecede olduğunu göstermiştir.

Araştırmada MBT Türkiye ve Güney Kore'de uygulandığı için her iki ülke bulguları için ayrı ayrı incelenmiştir. İç tutarlılık güvenilirlik katsayıları hesaplanmış, İstanbul verileri için Cronbach Alfa değeri 0,772 , Seul verileri için Cronbach Alfa değeri 0,900 olarak bulunmuştur. Ölçeğe ilişkin bulgular ölçeğin orijinalinde yapılan çalışmalardan elde edilen bulguları destekler niteliktedir (Çanakçı,2008).

Aile Değerlendirme Ölçeği

"Aile Değerlendirme Ölçeği (ADÖ)" Mc Master Aile İşlevleri Modeli (Bishop ve ark., 1983) temelinde hazırlanmış bir ölçektir. Ölçeğin ülkemize uyarlama çalışması Bulut (1990) tarafından yapılmıştır. Tüm aile üyeleri ve deneğin kendisinden aile işlevlerini 4 seçenek üzerinden değerlendirmesi istenir. 12 yaşın üzerindeki tüm aile üyelerine uygulanabilen ADÖ, 60 soru içermektedir ve 7 alt ölçekten oluşmaktadır. Bunlar; Problem Çözme (PRÇ), İletişim (İLT), Roller (RL) Duygusal Tepki Verme (DTV), Gereken İlgiyi Gösterme (GİG), Davranış Kontrolü (DVK) ve Genel İşlevler (GNF) dir. Ölçekten alınabilen en yüksek puan 4'dür. Yüksek puan "bozuk ailesel işlev"e işaret etmektedir. Aile puanı, tüm aile üyelerinin puan ortalamaları kullanılarak elde edilebilir.

Ölçek, güvenilirlik çalışması, iç tutarlılık ve puan değişmezliği açısından incelenmiştir. Alt ölçeklerin Cronbach-alfa katsayıları 0,38 ile 0,86 arasında değişmektedir. Ölçeğin toplam bir puanı olmadığından, her alt ölçek için

test tekrar test korelasyonu Pearson Momentler Çarpımı ile hesaplanmıştır. Alt ölçekler için korelasyon kat sayıları en düşük 0,62 ile en yüksek 0,90 arasında verilmiştir.

ADÖ Türkiye ve Güney Kore’de uygulandığı için her iki ülke bulguları için ayrı ayrı incelenmiştir. Ölçeğin İstanbul verileri için iç tutarlılıkta Cronbach Alfa değerleri problem çözme için 0,659 ; iletişim için 0,621 ; roller için 0,591 ; duygusal tepki verebilme için 0,662 ; gereken ilgiyi gösterme için 0,354 ; davranış kontrolü için 0,203 ve genel işlevler için 0,855 olarak belirlenmiştir. Ölçeğin Seul verileri için iç tutarlılıkta Cronbach Alfa değerleri problem çözme için 0,638 ; iletişim için 0,722 ; roller için 0,508 ; duygusal tepki verebilme için 0,723 ; gereken ilgiyi gösterme için 0,251 ; davranış kontrolü için 0,202 ve genel işlevler için 0,796 olarak belirlenmiştir. Ölçeğe ilişkin bulgular ölçeğin orijinalinde yapılan çalışmalardan elde edilen bulguları destekler niteliktedir (Bulut,1990). Ayrıca ölçek Korece ve Türkçe’ye hakim bir gruba bir hafta arayla uygulanarak dil eşdeğerliği testi yapılmıştır.

Ölçeğin sadece 12 maddelik *Genel İşlevler* alt boyutu üzerine yapılan bir araştırmada geçerlilik ve güvenilirlik çalışmaları yapılmış ve bu alt ölçeğin diğer alt ölçeklerle de desteklendiği görülmüştür (Byles ve ark, 1988). Yani sadece *Genel İşlevler* alt ölçeğinin sonuçları dikkate alınarak aile işlevselliği ile matematik başarısı arasındaki ilişkiyi ortaya koymak mümkündür. Buna dayanarak çalışmada ADÖ’nün sadece *Genel İşlevler* alt boyutu ele alınmıştır. ADÖ’nün Genel İşlevler alt boyutu ile MBT’den alınan puan arasında bir ilişki olup olmadığını incelemek için analizler yapılmıştır.

BULGULAR

Analizler Türkiye ve Güney Kore verileri için ayrı ayrı yapılmıştır. Öğrencilerin Matematik Başarı Testinden aldıkları puanlar ile Aile Değerlendirme Ölçeğinin “Genel İşlevler” alt boyutundan aldıkları puanlar arasındaki korelasyon incelenmiştir. İlişkinin daha net bir şekilde görülebilmesi için veriler kategorik olarak ifade edilerek ki-kare testi yapılmıştır.

Verilerin normalliği incelendikten sonra (Kolmogorov-Smirnov, $p < 0,001$) öğrencilerin matematik başarılarının buldukları şehirlere göre farklılık gösterip göstermediğini incelemek için Bağımsız grup T-testi yapılmıştır.

Tablo 1. Öğrencilerin Matematik Başarılarının Yaşadıkları Şehirlere Göre Karşılaştırılması (N=617)

Şehirler	N	Ort	SS	T	P
İstanbul	319	11,27	4,62		
Seul	298	18,10	5,77	-16,257	0,000

Tablo 1’e göre Seul’deki öğrencilerin (Koreli öğrenciler) İstanbul’daki öğrencilerden (Türk öğrenciler) daha başarılı olduğu saptamıştır. Tabloda Seul’deki öğrencilerin MBT’den aldıkları puanların ortalaması 18,10 iken İstanbul’daki öğrencilerin MBT’den aldıkları puanların ortalamasının 11,27 olduğu görülmektedir.

ADÖ verilerinin normal bir dağılıma sahip olduğu görüldükten sonra (Kolmogorov-Smirnov, $p < 0,001$) Genel İşlevler alt boyut puanlarının yaşadıkları şehirlere göre farklılık gösterip göstermediğini incelemek için Bağımsız grup T-testi yapılmıştır.

Tablo 2. Öğrencilerin Genel İşlevler Alt Boyutundan Aldıkları Puanların Yaşadıkları Şehirlere Göre Karşılaştırılması

Şehirler	Ort	SS	T	P
İstanbul	1,68	0,56		
Seul	1,90	0,52	-5,063	0,000

ADÖ puanlarının 2’den büyük olması bozuk aile işlevini gösterdiği (Bulut,1990) ve hem Türk hem Koreli öğrencilerin ADÖ puanları 2’den küçük olduğu için genel anlamda öğrencilerin aile işlevlerini sağlıklı algıladıkları söylenebilmektedir (Tablo 2). İstanbul’daki öğrencilerin ADÖ’den aldıkları puanların ortalaması 1,68 iken Seul’deki öğrencilerin ADÖ’den aldıkları puanların ortalamasının 1,90 olduğu görülmektedir. Dolayısıyla İstanbul’daki öğrencilerin (Türk öğrenciler) ailelerini, Seul’deki öğrencilerden (Koreli öğrenciler) daha sağlıklı algıladıkları söylenebilmektedir.

İstanbul ve Seul verileri için ayrı ayrı korelasyonlar incelenmiş ve sonuçları aşağıda tablolarla gösterilmiştir.

Tablo 3. Genel İşlevler Alt Boyutu Puanı İle Matematik Başarı Testi Puanı Arasındaki Korelasyon (İstanbul)

	Matematik Başarı Testi	Genel İşlevler
Matematik Başarı Testi	1	
Genel İşlevler	-0,172	1

İstanbul'daki öğrencilerin MBT'den aldıkları puanlarla ADÖ'nin *Genel İşlevler* alt boyutundan aldıkları puanlar arasındaki korelasyon yukarıdaki tabloda gösterilmiştir. Buna göre İstanbul'daki öğrencilerin genel olarak aile işlevlerini algılama biçimi ile matematik başarıları arasında pozitif bir ilişkiden söz edilebilmektedir.

Tablo 4. Genel İşlevler Alt Boyutu Puanı İle Matematik Başarı Testi Puanı Arasındaki Korelasyon (Seul)

	Matematik Başarı Testi	Genel İşlevler
Matematik Başarı Testi	1	
Genel İşlevler	-0,186	1

Seul'deki öğrencilerin MBT'den aldıkları puanlarla ADÖ'nin *Genel İşlevler* alt boyutundan aldıkları puanlar arasındaki korelasyon yukarıdaki tabloda gösterilmiştir. Buna göre Seul'deki öğrencilerin genel olarak aile işlevlerini algılama biçimi ile matematik başarıları arasında pozitif bir ilişki olduğu söylenebilmektedir.

Aile Değerlendirme Ölçeğinin alt boyutları ile Matematik Başarı Testi sonuçları arasındaki ilişkiyi daha net bir şekilde görebilmek için onları kategorik olarak ifade etmek gerekmektedir. Çünkü öğrencilerin buldukları sınıf düzeyi ve yaşadıkları şehirler farklılık göstermektedir. Bu nedenle öğrencilerin eğitim gördükleri okul ve sınıf düzeyleri için ayrı ayrı aritmetik ortalamalar alınıp ortalamaların altındakiler "başarısız", ortalamanın üstündekiler "başarılı" olarak sınıflandırılmıştır. Aile Değerlendirme Ölçeğinin her bir alt boyutu için 2 puan değerinin altındakiler "sağsız", 2 puan değerinin üstündekiler "sağlıklı" şeklinde sınıflandırılmıştır. Daha sonra bu iki kategorik değişken arasında anlamlı ilişki olup olmadığını belirlemek için ki-kare testi yapılmıştır.

Tablo 5. Öğrencilerin Genel İşlevler Alt Boyutuna Göre Başarı Durumları (İstanbul)

Genel İşlevler	Matematik Başarı Durumları		TOPLAM	χ^2	P
	Başarılı	Başarısız			
Sağlıklı	149	90	239	7,400	0,007
Sağsız	36	44	80		
TOPLAM	185	134	319		

Sadece İstanbul'da yaşayan öğrenciler seçilerek ki-kare testi yapıldığında genel işlevler alt boyutu bakımından aileyi sağlıklı veya sağsız algılama ile matematik başarıları arasında anlamlı bir ilişki olduğu tespit edilmiştir ($\chi^2 = 7,400$, $p < 0,05$). Yani bu boyut açısından ailelerini sağlıklı algılayan öğrencilerin daha başarılı olduğu sonucuna ulaşılmıştır (Tablo 5).

Tablo 6. Öğrencilerin Genel İşlevler Alt Boyutuna Göre Başarı Durumları (Seul)

Genel İşlevler	Matematik Başarı Durumları		TOPLAM	χ^2	P
	Başarılı	Başarısız			
Sağlıklı	135	47	182	6,313	0,012
Sağsız	70	46	116		
TOPLAM	205	93	298		

Tablo 6'ya göre sadece Seul'de yaşayan öğrenciler seçilerek ki-kare testi yapıldığında genel işlevler alt boyutu bakımından aileyi sağlıklı veya sağsız algılama ile matematik başarıları arasında anlamlı bir ilişki olduğu tespit edilmiştir ($\chi^2 = 6,313$, $p < 0,05$). Yani bu boyut açısından ailelerini sağlıklı algılayan öğrencilerin matematikte daha başarılı olduğu sonucuna ulaşılmıştır.

SONUÇ VE ÖNERİLER

Bu çalışma Seul(Güney Kore) ve İstanbul(Türkiye)'dan 13-14 yaş grubundaki öğrencilerin katılımıyla gerçekleştirilmiştir. Aile işlevselliğinin alt boyutlarından "Genel İşlevler" boyutu ele alınarak öğrencilerin bu boyut açısından ailelerini nasıl algıladıkları ile matematik başarıları arasında herhangi bir ilişki olup olmadığı araştırılmıştır.

Koreli ve Türk öğrencilerin Matematik Başarı Testi'nden aldıkları puanlarda bağımsız grup T-testi yapıldığında Koreli öğrencilerin Türk öğrencilerden daha başarılı olduğu görülmüştür. Bu durum TIMSS sonuçlarıyla da uyumludur (TIMSS 1999, TIMSS 2007, TIMSS 2011). Aile Değerlendirme Ölçeği'nin "Genel İşlevler" alt boyutundan alınan puanlarla bağımsız grup T-testi yapıldığında hem Koreli öğrencilerin hem Türk öğrencilerin bu boyut açısından ailelerini sağlıklı algıladıkları görülmüştür. Bu sonuç; Dil ve Bulantekin'in (2011) hemşirelik öğrencileri üzerinde yaptıkları, öğrencilerin *gereken ilgiyi gösterme* ve *davranış kontrolü* boyutlarındaki aile işlevlerini sağlıklı algıladıkları, diğer boyutlarda ise ailelerini sağlıklı algıladıkları sonucuna ulaştıkları çalışmayla desteklenmektedir. Ayrıca korelasyon değerleri hem Türkiye için hem Güney Kore için öğrencilerin ailelerini "Genel İşlevler" işlevi açısından sağlıklı algılayıp algılamama durumları ile Matematik Başarı Testi'nden aldıkları puanların ilişkili olduğunu ortaya koymuştur.

Ki-kare testinden elde edilen bulgulara göre hem Türk öğrenciler hem Koreli öğrencilerden ailelerini *Genel İşlevler* alt boyutu bakımından sağlıklı algılayan öğrencilerin daha başarılı olduğu söylenebilir. Yani her iki ülke için de elde edilen bulgular birbirini destekler niteliktedir. Aile işlevselliğinin *Genel İşlevler* alt boyutu tüm boyutların özeti niteliğinde genel sonuçları içeren bir alt ölçektir (Byles ve ark, 1988). Dolayısıyla sadece *Genel İşlevler* alt ölçeğinin sonuçları dikkate alınarak aile işlevselliği ile matematik başarıları arasındaki ilişkiyi ortaya koymak mümkündür. Araştırmadaki söz konusu boyuta ait bulgulara dayanarak aile işlevselliği ile matematik başarıları arasında bir ilişki olduğu söylenebilir.

Bu çalışmada öğrencilerin sadece aile işlevlerini nasıl algıladıklarına bakılmış, ailenin diğer birçok özelliği dikkate alınmamıştır. Dolayısıyla bu durum araştırmadan beklediğimizden çok daha zayıf bir ilişki bulunmasına sebep olmuş olabilir. Aile işlevselliğinin öğrencinin matematik başarılarıyla veya en genel haliyle akademik başarıyla olan ilişkisini daha net bir şekilde tespit edebilmek için amaçlı örneklem seçimi yapılabilir. Sosyo-ekonomik düzeyleri veya anne-baba durumları gibi faktörler göz önüne alınarak örneklem belirlenebilir. Böylece daha gerçekçi sonuçlara ulaşmak mümkün olabilir. Bu konuda çalışmak isteyen araştırmacılara örneklemelerini oluştururken bu hususlara dikkat etmeleri önerilir.

KAYNAKLAR

- Bishop, D., Epstein, N., Keitner, G., Miller, I., Ryan, C., (2000). The Mc Master Approach to Families: Theory, Assessment, Treatment and Research, *Journal of Family Therapy*, 22:168 – 189.
- Bulut, F. (2010). Ergenlerde Görülen Kural Dışı Davranışların Aile İşlevselliği, Aile Risk Faktörü ve Yaşam Kalitesi Açısından İncelenmesi. *Yayınlanmamış Yüksek Lisans Tezi, Adana*.
- Bulut, I. (1990). Aile Değerlendirme Ölçeği El Kitabı. *Özgüzel Matbaası, Ankara*.
- Byles, J., Byrne, C., Boyle, M.H., Offord, D.R. (1988). Ontario Child Health Study: Reliability and Validity of the General Functioning Subscale of the McMaster Family Assessment Device, *Family Process Volume 27, Issue 1, March 1988*.
- Cho, I.K. (1997). Güney Kore Eğitim Sistemi ile Türkiye Eğitim Sisteminin Karşılaştırılması. *Yayınlanmamış Yüksek Lisans Tezi, İstanbul*.
- Çanakçı, O. (2008). Matematik Problemi Çözme Tutum Ölçeğinin Geliştirilmesi ve Değerlendirilmesi. *Yayınlanmamış Doktora Tezi, Marmara Üniversitesi, Eğitim Bilimleri Enstitüsü, İstanbul*.
- Dil, S. ve Bulantekin, Ö. (2011). Hemşirelik Öğrencilerinde Akademik Başarı Düzeyi ile Aile İşlevselliği ve Kontrol Odağı Arasındaki İlişkinin Belirlenmesi. *Psikiyatri Hemşireliği Dergisi, Journal of Psychiatric Nursing 2011; 2(1):17- 24*.
- Dursun, Ş. ve Dede, Y. (2004). Öğrencilerin Matematikte Başarısını Etkileyen Faktörler: Matematik Öğretmenlerinin Görüşleri Bakımından.
- Keskin, G. ve Sezgin, B. (2009). Bir Grup Ergende Akademik Başarı Durumuna Etki Eden Etmenlerin Belirlenmesi. *Fırat Sağlık Hizmetleri Dergisi, Cilt 4, Sayı:10*
- Mandara, J. (2006). The Impact of Family Functioning on African American Males" Academic Achievement: A Review and Clarification of the Empirical Literature. *Teachers College Record Volume 108, Number 2, February 2006, pp.206-223*.
- Yenilmez, K. ve Duman, A. (2008) İlköğretimde Matematik Başarısını Etkileyen Faktörlere İlişkin Öğrenci Görüşleri.
- Yücel, C., Karadağ, E., Turan, S. (2013, Şubat). TIMSS 2011 Ulusal Ön Değerlendirme Raporu. *Eskişehir Osmangazi Üniversitesi Eğitim Fakültesi Eğitimde Politika Analizi Raporlar Serisi I, Eskişehir*.

10. SINIF ÖĞRENCİLERİNİN ÖTELEME VE DÖNME DÖNÜŞÜMLERİYLE İLGİLİ MATEMATİKSEL ANLAMALARININ GELİŞİMİNDE SANAL MANİPÜLATİFLERİN ROLÜ

THE ROLE OF VIRTUAL MANIPULATIVES IN 10TH GRADE STUDENTS' GROWTH OF MATHEMATICAL UNDERSTANDING ABOUT TRANSLATION AND ROTATION TRANSFORMATIONS

Hilal GÜLKILIK
Gazi Üniversitesi Gazi Eğitim Fakültesi
ghilal@gazi.edu.tr

Hasan Hüseyin UĞURLU
Gazi Üniversitesi Gazi Eğitim Fakültesi
hugurlu@gazi.edu.tr

Nejla YÜRÜK
Gazi Üniversitesi Gazi Eğitim Fakültesi
nejlayuruk@gazi.edu.tr

ÖZET: Bu araştırmanın amacı, 10. sınıf öğrencilerinin, sanal manipülatiflerle geçirdikleri deneyimlerin, öteleme ve dönme dönüşümlerine ait matematiksel anlamalarında nasıl bir rol oynadığını belirlemektir. Bir durum çalışması olarak tasarlanan çalışmada veri, bu dönüşümlere ait görev temelli görüşmeler ve ilgili derslerde gerçekleştirilen katılımcı gözlemler yoluyla elde edilmiştir. Dersler, dönüşümlere yönelik çoklu temsillerden sözel, grafiksel ve cebirsel temsillere ek olarak sanal ve fiziksel manipülatiflerle zenginleştirilmiştir. Her bir dersin ardından, araştırma sınıfından amaçlı bir şekilde belirlenen dört öğrenci ile bu dönüşümlere yönelik görüşmeler gerçekleştirilmiştir. Anlamalarındaki kalıcılığı belirleyebilmek amacıyla, katılımcılarla 18 hafta sonra tekrar bir araya gelinerek kavramlara yönelik görev temelli yeni görüşmeler gerçekleştirilmiştir. Elde edilen veri, araştırmanın kavramsal çerçevesini belirleyen Pirie-Kieren ve temsil teorisi temel alınarak analiz edilmiştir. Sonuçlar, öğrencilerin öteleme ve dönme dönüşümleriyle ilgili matematiksel anlamalarını şekillendirirken sanal manipülatifleri farklı anlama seviyelerinde, geriye katlama hareketlerinde, ortamdaki müdahaleleri anlamlandırmada kullandıklarını göstermektedir. Ayrıca sanal manipülatifler, öğrencilerin kavramlara ait farklı temsilleri anlamlandırmalarına ve kullanmalarına yardımcı olmaktadır.

Anahtar sözcükler: matematiksel anlama, sanal manipülatifler, öteleme, dönme

ABSTRACT: The purpose of this qualitative case study was to investigate the role of 10th grade students' manipulative experiences in their mathematical understanding about translation and rotation. The data collected by task-based semi-structured interview forms and observation notes of the each transformation lesson. The lessons were enriched with virtual and physical manipulatives in addition to verbal, graphical and algebraic representations of mathematical concepts. Participants, four students who were selected purposively from the classroom, were interviewed about transformations before and after the lessons. In order to investigate the persistency in understanding new interviews were conducted with them 18 weeks after the lessons. The data were analyzed according to Pirie-Kieren and representation theory. The results indicated that students used virtual manipulatives while working within different levels of mathematical understanding, making folding back movements and comprehending the interventions. Virtual manipulatives helped students to understand and apply the different representations in different mathematical understanding levels.

Key words: mathematical understanding, virtual manipulatives, translation, rotation

FEN BİLİMLERİ ÖĞRETMENLERİNİN ALTERNATİF ÖLÇME DEĞERLENDİRME ARAÇLARINI KULLANMA DURUMLARI

Ummuhan ORMANCI

Salih CEPNİ

Fen bilimleri programı incelendiğinde; öğretmen ve öğrencilerin öğrenme-öğretme sürecince kavram karikatürü, rubrik, yapılandırılmış grid, günlük, tanılayıcı dallanmış ağaç gibi alternatif ölçme değerlendirme araçlarını etkin şekilde kullanmaları beklenmektedir. Alan yazın incelendiğinde; öğretmenlerin alternatif ölçme-değerlendirme araçlarını kullanma durumlarına ilişkin çalışmalar olmasına rağmen, bu çalışmaların genellikle öğretmenlere anket, görüşme vb. yöntemlerle direk iletişim kurularak yapıldığı anlaşılmaktadır. Buna karşın öğretim süreci boyunca öğretmenleri gözlemleyerek yapılan çalışmaların yeterli sayıda olmadığı düşünülmektedir. Bu bağlamda; öğretmenlerinin alternatif ölçme değerlendirme araçlarını kullanma durumlarının sınıf ortamında gerçekleştirilen gözlemlerle belirlenmesinin önemli olacağı düşünülmektedir. Yapılan çalışmada; fen bilimleri öğretmenlerinin alternatif ölçme değerlendirme araçlarını sınıf ortamlarında kullanma durumlarının belirlenmesi amaçlanmıştır. Çalışmada; nitel araştırma yöntemlerinden özel durum çalışması kullanılmıştır. Bu amaçla çalışma, Bursa ilinde yer bir ortaokulda, üç fen bilimleri öğretmeni ve sınıflarıyla gerçekleştirilmiştir. Çalışma sekiz hafta boyunca ve her hafta 4 ders saati gözlem yapılarak sürdürülmüştür. Bu süreçte veri toplama aracı olarak; alternatif ölçme-değerlendirme araçlarına ilişkin kontrol listesi ve gözlem formu kullanılmıştır. Ayrıca süreç sonunda üç fen bilimleri öğretmeniyle görüşmeler gerçekleştirilmiştir. Çalışmadan elde edilen veriler; frekans-yüzde değerleri ve betimsel analiz yöntemi kullanılarak analiz edilecektir. Veriler şu anda analiz aşamasında olmakla birlikte, analiz sonucunda fen bilimleri öğretmenlerinin kullandığı alternatif ölçme-değerlendirme araçları belirlenecek, bunları kullanma sıklıkları hakkında bilgi verilecektir. Gözlem notlarından elde edilen veriler, öğretmenlerin alternatif ölçme değerlendirme araçlarını nasıl kullandığına ilişkin derinlemesine bilgi verecektir. Ayrıca yapılan gözlemler ve öğretmenlerle yapılan görüşmeler sonucunda, öğretmenlerin sınıflarında kullandıkları alternatif ölçme-değerlendirme araçları açısından karşılaştırması planlanmaktadır.

Anahtar Kelimeler: Fen bilimleri, öğretmen, alternatif ölçme değerlendirme

GRAFİK HESAP MAKİNESİ İLE TRİGONOMETRİ ÖĞRETİMİ: BİR EYLEM ARAŞTIRMASI

Ali ŞİMŞEK

Emine ŞİMŞEK

Eylem araştırmalarının amacı eğitim sürecinde ortaya çıkan gerçekleri sistemli bir şekilde anlamak ve sunmaktır. Bu araştırmalarda ölçme, keşfetme, araştırma, tartışma, belgelendirme, değerlendirme, analiz etme, iyileştirme ve gözden geçirme eylemlerinin döngüsel olarak gerçekleştiği görülür. Kendi uygulamalarını gözlemlene, önceden var olan ya da öğretim sürecinde ortaya çıkan bir sorunu anlama ve olası çözümleri üretmeye yönelik planlı, düzenlenmiş ve başkalarıyla paylaşılan bir sorgulama süreci olarak eylem araştırması, eğitim alanında kuram ile uygulama arasındaki boşluğu doldurabilecek bir köprü olarak görülmektedir. Eylem araştırmalarında, araştırmacı öğretmenler nasıl öğreteceklerine ve öğrencilerin nasıl öğreneceklerine dair yollar bulmak böylece öğretimi iyileştirmek için sistemli bir şekilde araştırmalar yürütür, derinlemesine bilgi toplar.

Öğrenciler Ortaöğretim Matematik Dersi Öğretim Programı (2011) “trigonometri” öğrenme alanında yer alan kazanımlara ulaşmada güçlüklerle karşılaşmaktadır. Bu araştırmanın amacı trigonometri konusunda öğrencilerin yaşadıkları güçlükleri gidermede grafik hesap makinesi ile hazırlanmış etkinlikler kullanılarak yapılan öğretimin etkisini belirlemektir. Bu amaçla araştırma “eylem araştırması” yaklaşımı ile yürütülmüştür. Araştırma 2013 – 2014 eğitim öğretim yılı bahar döneminde Ankara İli’ nin Kazan İlçesi’ nde bir ortaöğretim kurumunun 10. sınıflarından birinde okuyan 20 öğrenci ile yürütülmüştür. Öğrencilerin sahip oldukları kavram yanlışları, hatalar ve öğrenme zorlukları literatür taraması, öğretmenin deneyimleri ve öğrencilerin açık uçlu sorulara verdikleri yanıtlar aracılığıyla tespit edilmiştir. Bu olumsuzlukların giderilmesi için araştırmacılar hem yabancı literatürde var olan grafik hesap makinesi destekli etkinlikleri uyarlamış, hem de grafik hesap makinesi destekli etkinlikler tasarlamışlardır. Uygulamalar aynı okulda görev yapan matematik öğretmeni araştırmacı tarafından bu etkinlikler kullanılarak gerçekleştirilmiştir. Araştırmada veri toplama araçları olarak araştırmacı günlükleri, çalışma yaprakları, açık uçlu sorular ve klinik görüşmelerden yararlanılmıştır. Verilerin analizi ile elde edilen bulgular, uygulamaların öğrencilerin öğrenme düzeylerine katkı sağladığını göstermiştir. Bu bulgular ışığında okullarda trigonometri konusunda etkili öğrenme-öğretme ortamlarının nasıl yapılandırılacağı tartışılacaktır.

Anahtar Kelimeler: Trigonometri Öğretimi, Grafik Hesap Makinesi, Eylem Araştırması

oooooooooooooooooooo

GRAFİK HESAP MAKİNESİ İLE TRİGONOMETRİ ÖĞRETİMİ: BİR EYLEM ARAŞTIRMASI

Ali ŞİMŞEK

Emine ŞİMŞEK

Eylem araştırmalarının amacı eğitim sürecinde ortaya çıkan gerçekleri sistemli bir şekilde anlamak ve sunmaktır. Bu araştırmalarda ölçme, keşfetme, araştırma, tartışma, belgelendirme, değerlendirme, analiz etme, iyileştirme ve gözden geçirme eylemlerinin döngüsel olarak gerçekleştiği görülür. Kendi uygulamalarını gözlemlene, önceden var olan ya da öğretim sürecinde ortaya çıkan bir sorunu anlama ve olası çözümleri üretmeye yönelik planlı, düzenlenmiş ve başkalarıyla paylaşılan bir sorgulama süreci olarak eylem araştırması, eğitim alanında kuram ile uygulama arasındaki boşluğu doldurabilecek bir köprü olarak görülmektedir. Eylem araştırmalarında, araştırmacı öğretmenler nasıl öğreteceklerine ve öğrencilerin nasıl öğreneceklerine dair yollar bulmak böylece öğretimi iyileştirmek için sistemli bir şekilde araştırmalar yürütür, derinlemesine bilgi toplar.

Öğrenciler Ortaöğretim Matematik Dersi Öğretim Programı (2011) “trigonometri” öğrenme alanında yer alan kazanımlara ulaşmada güçlüklerle karşılaşmaktadır. Bu araştırmanın amacı trigonometri konusunda öğrencilerin yaşadıkları güçlükleri gidermede grafik hesap makinesi ile hazırlanmış etkinlikler kullanılarak yapılan öğretimin etkisini belirlemektir. Bu amaçla araştırma “eylem araştırması” yaklaşımı ile yürütülmüştür. Araştırma 2013 – 2014 eğitim öğretim yılı bahar döneminde Ankara İli’ nin Kazan İlçesi’ nde bir ortaöğretim kurumunun 10. sınıflarından birinde okuyan 20 öğrenci ile yürütülmüştür. Öğrencilerin sahip oldukları kavram yanlışları, hatalar ve öğrenme zorlukları literatür taraması, öğretmenin deneyimleri ve öğrencilerin açık uçlu sorulara verdikleri yanıtlar aracılığıyla tespit edilmiştir. Bu olumsuzlukların giderilmesi için araştırmacılar hem yabancı

literatürde var olan grafik hesap makinesi destekli etkinlikleri uyarlamış, hem de grafik hesap makinesi destekli etkinlikler tasarlamışlardır. Uygulamalar aynı okulda görev yapan matematik öğretmeni arařtırmacı tarafından bu etkinlikler kullanılarak gerekleřtirilmiřtir. Arařtırmada veri toplama araları olarak arařtırmacı gnlkleri, alıřma yaprakları, aık ulu sorular ve klinik grřmelerden yararlanılmıřtır. Verilerin analizi ile elde edilen bulgular, uygulamaların đrencilerin đrenme dzeylerine katkı sađladığını gstermiřtir. Bu bulgular ışığında okullarda trigonometri konusunda etkili đrenme-đretme ortamlarının nasıl yapılandırılabilceđi tartıřılacaktır.

Keywords: Teaching Trigonometry, Graphing Calculator, Action Research

MATEMATİK DERSİNE YÖNELİK TUTUM GELİŞTİRME İLE İLGİLİ YAPILMIŞ ARAŞTIRMALARA BİR BAKIŞ

A LOOK AT THE RESEARCHES WHICH WERE MADE ABOUT “IMPROVING THE ATTITUDE TOWARDS THE MATHEMATICS LESSON”

Dr. Özlem ÖZER
Milli Eğitim Bakanlığı
ozlemozer2001@gmail.com

ÖZET: Matematik dersine yönelik öğrenme öğretme süreçlerinde tutumun başarı üzerindeki etkisi yadsınamayacak kadar fazladır. Tutum, her bireyin yaşamında sürekli bir etkidir. Bu, herhangi bir durumda, kişinin algılama şeklini etkilemektedir. Yaşam boyu öğrenme ile olumlu tutum arasındaki ilişkilerde bu yaklaşım önem taşımaktadır. Bu yaklaşım ile bireyler yaşamlarındaki olumlu tutum ile çabaladıkları işler üzerinde daha büyük başarılar kazanmaktadır. Öğrencilerin matematik dersinde başarılı ya da başarısız olmalarında, matematiği sevmelerinde tutumların rolü büyüktür. Tutumlar başarıyı, başarı da tutumları etkilemektedirler. Matematik korkusu ve kaygısı üzerine yapılmış araştırmalar, öğrencilerin matematikle ilgili yaşantıları arttıkça, matematiğe karşı olumlu tutumlarında azalmalar gözlemlendiğini ortaya koymuştur. Bu düşünceden hareketle bu çalışmada, son yıllarda matematiğe yönelik tutumlar ile ilgili durumların ele alındığı çalışmalar incelenmiştir. Çalışmada kullanılacak makaleler yabancı literatürden seçilmiştir. 1999-2011 yılları arasındaki yapılmış araştırmalar “ mathematics” and “ attitude” anahtar sözcükleri temel alınarak taranmıştır. Matematiğe yönelik tutum geliştirme ile ilgili 14 araştırma incelenmiştir. Araştırma, tarama modelinde gerçekleştirilen betimsel bir çalışmadır.

Anahtar sözcükler: matematik eğitimi, tutum, öğrenme.

ABSTRACT: Attitude has an undeniable effective role in successfully teaching and learning process of mathematics lessons. Attitude has continous effects on one’s life and will effect an individual’s perception in different occasions. This approach has an important role in the relation of long life learning and positive attitude. With this approach and with the positive attitude individuals gain better success on the jobs they are working on. Attitude has an effective role on students acedemic success in mathematics and even like or dislike mathematics lessons. Attitude triggers success and success triggers attitude. Reasearches made on “The fear and worry of mathematics” showed that the more the students exposed to mathematics the lesser positive attitudes they had. Based on this thought in the recent years researches made on “Attitudes towards mathematics” examined. The articles used in the resarch will be chosen from the foreign sources. “Mathematics and attitude” key words were used in scanning the resources and formed the base of reseaches which were made between the years 1999-2011. A total of 14 researches done with improving the attitude towards the mathematics lesson studying were examined. This research is a descriptive study realized with screening method.

Key words: mathematics education, attitude, learning.

GİRİŞ

Matematik, bilimde olduğu kadar günlük hayatımızda karşılaştığımız sorunların çözümünde de kullandığımız önemli bir araçtır. Bundan dolayı, matematikle ilgili davranışlar ilköğretimden yükseköğretim programına kadar her alanda yer almaktadır.

Duyuşsal alan davranışlarının önemli bir bölümünü oluşturan tutum (Can,1991) bireyin ilgili bulunduğu tüm nesne ve durumlara olan tepkisi üzerinde yönlendirici ya da dinamik bir etkisi olan deneyimlerce biçimlenen zihinsel ve sinirsel bir hazır olma durumu olarak tanımlanmaktadır. Tutum, bireyin çevresindeki bir simgeyi, bir nesneyi ya da bir olayı olumlu ya da olumsuz değerlendirme eğilimi olarak da görülebilmektedir. Bu durumda, bireyler çevrelerindeki nesnelere ve olayları olumlu ya da olumsuz olarak değerlendirmekte ve tercihleri doğrultusunda tepki göstermektedirler (Harrel, 2000). Tutumun etkili olabilmesi için, öğrencilerin seçtikleri faaliyette başarılı olacağı ile ilgili beklentisinin büyüklüğü, tutum ile ilişkili etkinliğin sağlanması ve başarılı bir performans için geri bildirimde bulunmak gibi öğretimsel koşullar gereklidir (Driscoll, 2000). Öğrencilerin birçoğu hata yapma korkusuyla matematik etkinliklerinden uzak durmakta ve başarısız olmaktadır.

Duygusal ifade yönünden bakıldığında, olumlu tutum, matematik ile uğraşmaktan zevk almayı, olumsuz tutum ise, matematik ile ilgili bir sorun ile karşılaşıldığında kaygı duymayı ifade etmektedir. Davranış yönünden bakıldığında, “olumlu” genellikle “başarılı” anlamına gelmektedir. Okul bağlamında, başarılı davranış genellikle yüksek başarı ile özdeşleşmiştir (Isaiah, 2010).

İlköğretimden başlayarak, üniversiteye kadar, öğrencilerin en çok çekindikleri veya korktukları derslerin başında matematik dersi gelmektedir. Bu korkunun oluşmasında, matematik dersinin çok zor olmasından ziyade, öğrencilerde özellikle, ilköğretim yıllarında oluşan olumlu veya olumsuz tutumun etkisi büyük rol oynar. Bu bağlamda, okullarda matematiğe yönelik tutum ile ilgili çalışmaların incelenmesi ve sonuçların değerlendirilmesi önem taşımaktadır. Bu amaçla bu çalışmada, son on üç yılda öğrenme-öğretme sürecinde matematiğe yönelik tutumun, matematik başarısı üzerindeki etkileri ve cinsiyet faktörünün öğrencilerin matematiğe yönelik tutumları üzerindeki etkilerinin ele alındığı çalışmaların incelendiği bir betimsel tarama çalışması yapılmıştır. Bu çalışmanın gelecekte yapılacak olan çalışmalara yol gösterici olabileceği düşünülmektedir.

MATEMATİK DERSİNE YÖNELİK TUTUM GELİŞTİRME İLE İLGİLİ YURT DIŞINDA YAPILMIŞ ARAŞTIRMALAR (1999-2011)

Fraizer (1999) tarafından, yapılan bir araştırmada, Afrikalı kız öğrencilerin matematiğe yönelik tutumları ve başarı arasındaki ilişki incelenmiştir. Veri toplama aracı olarak, Matematik Tutum Ölçeği kullanılmıştır. Araştırmaya 140 tane ortaöğretimdeki kız öğrenci katılmıştır. Sonuçlar incelendiğinde, köy öğrencilerinin kentteki öğrencilere göre matematiğe yönelik olarak anlamlı düzeyde daha olumlu tutum geliştirdikleri saptanmıştır. Ayrıca, düşük ve yüksek başarıya sahip öğrenciler tutumları açısından karşılaştırıldığında, yüksek başarılı kız öğrencilerin düşük başarılı öğrencilere göre daha az endişeli tutuma sahip oldukları, problem çözmeye ve matematiğin yararlılığına yönelik olarak daha olumlu tutum geliştirdikleri tespit edilmiştir.

Martin (2002), “üstün yetenekli öğrencilerin matematiğe yönelik tutumları ile ilgili yaptığı araştırmada, ilköğretim düzeyindeki hızlandırılmış matematik programına katılan 3. 4. 5. ve 6. sınıftaki üstün yetenekli kız ve erkek öğrencilerin matematik dersine yönelik tutumlarını incelemiştir. Araştırmada, 267 tane üstün yetenekli kız ve erkek öğrencinin matematik dersine yönelik tutumlarını ölçmek için Matematik Tutum Ölçeği kullanılmıştır. Araştırma sonuçları incelendiğinde, kızlar ve erkekler arasındaki matematiğe yönelik tutum açısından en büyük farklılığın ve çeşitliliğin 5. sınıf düzeyinde olduğu belirlenmiştir. Veriler, erkek öğrencilerde genel olarak, daha olumlu bir matematik tutumunun olduğunu ortaya koyarken, en olumlu matematik tutumunun 4. sınıfta oluştuğu belirlenmiştir.

Sullivan ve Yu Ku (2002), “kişiselleştirilmiş matematik öğretiminde öğrenci performansı ve tutumlar” adlı araştırmayı, kişiselleştirilmiş öğretimin Tayvanlı öğrencilerin matematik problemlerindeki başarıları ve tutumları üzerindeki etkisini tespit etmek amacıyla yapmışlardır. Araştırmaya, 136 tane 4. sınıf öğrencisi katılmıştır. Araştırmada veri toplama aracı olarak, Matematik Tutum Ölçeği ve Matematik Başarı Testi kullanılmıştır. Elde edilen veriler incelendiğinde, kişiselleştirilmiş ön test ve son test problemlerinde öğrencilerin, kişiselleştirilmemiş problemlerin performansından önemli ölçüde daha iyi performans gösterdiği saptanmıştır. Ayrıca, öğrencilerin kişiselleştirilmiş öğretim programına, kişiselleştirilmemiş öğretim programından önemli ölçüde daha olumlu tutum geliştirdikleri tespit edilmiştir.

Hannula (2002) tarafından, yapılan “duygular, beklenti ve değerler” adlı araştırmada; tutuma yönelik olarak dört farklı değerlendirme süreci tanımlanmıştır. Bu süreçler, mevcut durumun uyandırdığı duygular, uyarılar ile ilişkili duygular, beklenen sonuçlar ve kişisel değerlere ilişkin durum şeklindedir. Araştırmada, bir ilköğretim okulundaki öğrencilerin matematiğe yönelik olumsuz tutumların tanımlanması ve sonrasında problem çözme durumunda olumsuz duyguların nasıl geliştiği vaka incelemesi ile incelenmiştir. Araştırma verileri incelendiğinde, 3 önemli sonuç elde edildiği görülmüştür. İlk olarak, duyguların, beklentilerin ve değerlerin önerilen çerçevede tutum ve değişiklikleri ayrıntılı olarak açıklamada yararlı olduğu, ikinci olarak, tutumların bazen oldukça kısa bir zaman içinde önemli ölçüde değiştirilebileceği, üçüncü olarak, matematiğe yönelik olumsuz tutumun, benlik kavramının olumlu ve başarılı bir savunma stratejisi olduğu tespit edilmiştir.

Luh, Guo ve Wisenbaker (2004) tarafından, “harp okulu öğrencileri ve üniversite öğrencileri arasındaki matematiğe yönelik tutumun, matematiksel yetenekler açısından farklılığını” istatistiksel olarak araştırmak ve karşılaştırmak amacıyla bir araştırma yapılmıştır. Araştırmaya harp okulu’ndaki 38 erkek öğrenci ve 43 tane üniversite öğrencisi katılmıştır. Araştırmada veri toplama aracı olarak, Matematik Tutum Ölçeği uygulanmıştır.

Sonuçlar incelendiğinde, her iki grupta da olumlu tutum geliştiği, ancak, algılanan matematik yeteneğinin ve matematik tutumunun üniversite öğrencilerinde daha yüksek düzeyde olduğu tespit edilmiştir.

Lianghuo, Seng ve Yan (2005), “Singapurlu öğrencilerin matematiğe yönelik tutumları ve matematik öğrenme” adlı araştırmayı yapmışlardır. Araştırmanın amacı, matematik ve matematik öğrenme ile ilgili öğrencilerin tutumlarını araştırmaktır. Araştırmada veri toplama aracı olarak, Matematik Tutum Ölçeği kullanılmıştır. Araştırmaya 1215 ortaöğretim öğrencisi katılmıştır. Veriler değerlendirildiğinde, öğrenciler matematiği genellikle ilginç bulduklarını (%73) ve matematik çalışmaktan zevk aldıklarını belirtmişlerdir. Ayrıca, öğrencilerin %77’sinin matematiği çok iyi öğrenme ve %61’inde matematik dersinden iyi notlar almak istedikleri yönündeki inançlarının olduğu tespit edilmiştir. Öğrencilerin %91’i matematiği faydalı, %89’u önemli ve %84’ü matematiği öğrenme için harcanan zamana değerli bulduklarını belirtmişlerdir.

Schackow (2005) tarafından, “ilköğretim okulu öğretmenlerinin hizmet öncesi matematik yöntemlerine giriş dersine yönelik tutumları ve bu tutumların gelişmesini etkileyen deneyimler” adlı çalışma yapılmıştır. Katılımcıların matematiğe yönelik tutumları ve bu tutumların gelişmesine yol açan deneyimler nitel yöntemler kullanılarak araştırılmıştır. Çalışmaya 33 üniversite öğrencisi katılmıştır. Veri toplama aracı olarak, “Matematik Tutum Ölçeği” verilmiştir. Sonuçlar, bir bütün olarak değerlendirildiğinde, katılımcılar üzerinde tutumun anlamlı düzeyde olumlu bir değişim gösterdiği saptanmıştır. Ayrıca, bireysel görüşmeler, belirtilen manipülatiflerin ve yöntem dersinin düzenli bir şekilde verilmesinin, katılımcıların matematiğe yönelik tutumları üzerinde önemli düzeyde değişiklikler gösterdiğini ortaya koymuştur.

Jenkins (2006), “matematik tutumlarını etkileyen faktörler” adını taşıyan araştırmasında, ilköğretim 6. sınıftaki 19 üstün yetenekli öğrencinin matematiğe yönelik tutumları ile bireysel matematik başarıları ve belirlenen zeka alanları arasındaki ilişkiyi incelemiştir. Araştırmada veriler “Matematik Tutum Ölçeği” ile toplanmıştır. Araştırma süresince, okuldaki üstün yetenekli öğrenciler için olan eğitim programına ilave olarak, aktif bir şekilde matematiksel yorumlar ve yaratıcı problem çözme etkinlikleri düzenlenmiştir. Elde edilen veriler incelendiğinde, öğrencilerin bazıları birden fazla zeka alanında üstün yetenekli iken, diğerlerinin sadece bir zeka alanında yetenekli oldukları ortaya çıkmıştır.

Zan ve Martino (2007), “matematiğe yönelik olumsuz tutum” olgusunu incelemek amacıyla yaptıkları araştırmada, günlükler, sınıf gözlemleri, anket, yapılandırılmış ve yarı yapılandırılmış görüşmelerle, denemeler kullanılmıştır. Araştırmaya 146 öğretmen katılmıştır. Veri toplama aracı olarak, Matematik Tutum Ölçeği kullanılmıştır. Araştırma verileri incelendiğinde, öğretmenlerin matematiğe yönelik tutumları ile inançları arasında anlamlı düzeyde ilişki bulunduğu tespit edilmiştir.

Ashyb (2009) tarafından, “öğrencilerin matematiğe yönelik tutumlarını araştırma” adını taşıyan bir çalışma yapılmıştır. Araştırmada, veri toplama aracı olarak, Matematik Tutum Ölçeği kullanılmıştır. Araştırma sonuçları genel olarak değerlendirildiğinde, öğrencilerin daha zor matematik problemlerini çözmeye kendilerini yetersiz ve zayıf olarak algılamakta oldukları saptanmıştır. Genel olarak, yüksek başarı gösterenler arasında kızlar erkeklerden daha fazla oranda düşük güvene sahip olduklarını belirtmişlerdir.

Yara (2009), Nijerya’nın güneybatısındaki seçilmiş ortaokullardaki öğrencilerin matematik dersine yönelik tutum ve akademik başarıları arasındaki ilişkiyi incelemiştir. Araştırmaya, orta ikinci sınıf öğrencilerinden 1542 tane üst düzey öğrenci katılmıştır. Bu öğrencilere Matematik Tutum Ölçeği verilmiştir. Araştırma sonuçları, öğrencilerin matematik dersine yönelik tutumlarının olumlu olduğunu, matematik dersini değerli ve gerekli bulduklarını ve gelecekteki kariyerleri için onlara yardımcı olabileceğini düşündüklerini ortaya koymuştur. Ayrıca, 1458 öğrenci (%83.3) problem çözmeden hoşlandıklarını, kalan 84 öğrenci (%16.7) ise hoşlanmadıklarını belirtmişlerdir. Bu oranlar dikkate alındığında, matematiğe yönelik tutum ile akademik başarı yönünden öğrencilerin önemli bir bölümünün problem çözmeyi sevdiği, çok az bölümünün hoşlanmadığı belirlenmiştir.

Schenkel (2009) tarafından, “matematik dersine yönelik tutumun matematik performansı üzerine etkisi” adlı araştırma yapılmıştır. Nicel ve nitel yöntemin kullanıldığı araştırmaya 79 öğrenci ve 23 öğretmen katılmıştır. Araştırmada, 8.sınıftaki öğrencilerin matematik performansına, öğretmenlerin ve öğrencilerin tutumlarının etkisi incelenmiştir. Araştırmada, veri toplama aracı olarak, Matematik Tutum Ölçeği kullanılmıştır. Veri analizleri sonrasında, matematik dersine yönelik olumlu bir tutuma sahip olma ile öğrencilerin sınıf performansı arasında pozitif ilişki olduğu ortaya çıkmıştır. Araştırmada, öğretmenlerin çabaları ile öğrencilerde olumlu tutumun ve sınıftaki performansın geliştirilmesi arasında pozitif bir ilişki tespit edilmiş olup, öğrenciler, öğretmenlerin matematik dersini eğlenceli hale getirmelerinin, onların katılımını ve yetenek düzeylerini arttırmada yardımcı olduğunu belirtmişlerdir.

Farooq ve Shah (2010) tarafından, yapılan bir başka çalışmada; “öğrencilerin matematiğe yönelik tutumu, güveni, matematiğin kullanılabilirliğini ve aynı zamanda, öğretmen algısı ve erkeklerin matematikteki etki alanlarını” ölçmek amaçlanmıştır. Çalışmaya, 685 öğrenci katılmıştır. Araştırmada veriler, Matematik Tutum Ölçeği ile toplanmıştır. Araştırma sonuçları incelendiğinde, ortaöğretim düzeyindeki kız ve erkek öğrencilerin matematiğe yönelik güvenleri açısından anlamlı bir fark tespit edilirken, matematik öğretmeni hakkındaki algıları ve matematiğin kullanılabilirliği ile ilgili olarak kız ve erkek öğrenciler arasında anlamlı bir fark olmadığı saptanmıştır.

Lawsha ve Hussain (2011), Maldivlerden seçilen bir orta dereceli okuldaki öğrencilerin matematiğe yönelik tutumlarını incelemişlerdir. Çalışmada, bir ortaokuldaki öğrencilerin cinsiyet farklılığının matematiğe yönelik tutum üzerindeki etkisi belirlenmeye çalışılmıştır. Toplamda 200 ortaöğretim öğrencisi çalışmaya katılmıştır. Araştırmada veri toplama aracı olarak, Matematik Tutum Ölçeği kullanılmıştır. Veriler değerlendirildiğinde, öğrencilerin matematik performansı düşük olmasına rağmen, katılımcıların tutumunun oldukça olumlu olduğu tespit edilmiştir. Ayrıca, çalışmada öğrencilerin matematiğe yönelik tutumuna yönelik olarak kız ve erkek öğrenciler arasında anlamlı bir fark olmadığı ortaya çıkmıştır.

SONUÇ VE ÖNERİLER

Çalışma kapsamında yer alan araştırmaların sonuçları incelendiğinde, matematiğe yönelik tutum ile başarı arasındaki ilişkinin ve cinsiyet farklılığının matematiğe yönelik tutum üzerindeki etkilerinin irdelenmiş olduğu görülmektedir. Araştırmalarda yapılan veri analizleri değerlendirildiğinde, matematik dersine yönelik olumlu bir tutuma sahip olma ile öğrencilerin sınıf performansı arasında pozitif ilişki olduğu ulaşılan ortak sonuçtur. Matematiğe yönelik geliştirilen olumlu tutumun matematik ders başarısını yükselttiği yönünde sonuçlar elde edilirken, matematiğe yönelik olarak geliştirilen olumsuz tutumun akademik başarıyı negatif yönde etkilediği ortaya çıkmıştır. Ayrıca, eğitimin her düzeyinde matematik dersinin eğlenceli hale getirilmesinin öğrenci motivasyonunu ve buna paralel olarak öğrenci katılımını ve yetenek düzeyini arttıracak sonucuna ulaşılmıştır.

Ayrıca, matematik dersinin öğrenciler tarafından yaşadıkları başarısızlık yaşantıları nedeniyle, pek sevilmeyen bir ders olduğu ve bu nedenle bu derse yönelik olarak olumsuz tutum geliştirdikleri gözlenmektedir. Başarıyı tadamayan öğrencilerin öğrenilmiş çaresizliği yaşamakta olduğu ve dolayısıyla bu derse yönelik olarak olumsuz tutum geliştirdikleri söylenebilir. Öğrencilerin başarıyı tatmalarının sağlanması ile bu derse karşı olumlu tutum geliştirmeleri sağlanabilir. Ayrıca, eğitim sistemimizde matematik dersinin, öğrencinin geleceğinde ve okul seçiminde belirleyici bir ders olmasının, öğrencilerin bu derse karşı olumlu tutum geliştirmesinde etkili olduğu söylenebilir. Bu bağlamda, öğrencilere yönelik yapılacak yönlendirme çalışmaları etkili olabilir.

KAYNAKLAR

- Ashby, B. (2009). *Exploring children's attitudes towards mathematics*. Joubert, M. (Ed.) Proceedings of the British Society for Research into Learning Mathematics 29(1).
- Can G.(1991). "Eğitim Fakültesi ve Öğretmenlik Sertifikası Programlarının Öğretmen Adaylarının Tutum Geliştirme Açısından Etkililiği", İzmir I. Ulusal Eğitim Kongresi, İZMİR.
- Driscoll, Marcy P. (2000). Gagne's theory of instruction. Florida State University. Psychology of Learning for Instruction. Second Edition. Chapter 10.
- Farooq, M. ve Shah, S. (2010). Students' attitude towards mathematics gender and mathematics performance. *Pakistan Economic and Social Review*, 46 (1), 75-83.
- Fraizer, S. (1999). A psychological study of mathematics attitudes and achievement among female Ivorian students. Institute for Social Research University of Michigan, 268 , 1-18.
- Hannula, M. (2002). Attitude towards mathematics: Emotions, expectations and values. *Educational Studies in Mathematics*, 49, 25-46.
- Harrel, K. (2000). *Attitude is everything*. New York: John Willey and Sons. Inc.
- Isaiah, R. (2010). The attitude factor. The impact of attitude in lifelong. Learning,. *Relationships, and Success in Life*. North Star High School, 23-31.
- Jenkins, N. (2006). Factors that influence mathematics attitudes. A report on an action research project submitted in partial fulfillment of the requirements for Master of Arts in the Department of Teaching, Learning and Teacher Education, University of Nebraska-Lincoln.
- Lawsha, M. ve Hussain, W. (2010). Secondary students' attitudes towards mathematics in a selected school of Maldives. *International Journal of Humanities and Social Science*, 1 (15), 277-281.

- Lianghuo, F., Seng, Q ve Yan, Z. (2005). Assessing Singapore students' attitudes toward mathematics and mathematics learning: Findings from a survey of lower secondary students. Nanyang Technological University Singapore.
- Luh,W.M., Guo, J.H. ve Wisenbaker, J.M. (2004). Difference of attitudes toward statistics between cadets and college students. International Congress on Mathematical Education in Denmark, 4-11.
- Martin, R.M. (2002). Math attitudes of gifted Students: A focus on gifted girls in the elementary grades dissertation submitted to the faculty of the Virginia Polytechnic Institute and State University in partial fulfillment of the requirements for the degree of Doctor of Education in Educational Leadership and Policy Studies.
- Schackow, J. (2005). Examining the attitudes toward mathematics of preservice elementary school teachers enrolled in an introductory mathematics methods course and the experiences that have influenced the development of these attitudes. *A dissertation submitted in partial fulfillment of the requirements for the degree of Doctor of Philosophy Department of Secondary Education College of Education University of South Florida.*
- Schenkel, B. (2009). The impact of an attitude toward mathematics on mathematics performance. A Thesis Presented in Partial Fulfillment of the Requirements for The Degree Master of Arts in Education at Marietta College.
- Sullivan, H. ve Yu Ku, Hong. (2002). Student performance and attitudes using personalized mathematics instruction, 50 (1), 21-34.
- Yara, P. O.(2009). Students attitude towards mathematics and academic achievement in some selected secondary schools in Southwestern Nigeria. *European Journal of Scientific Research*, 36(3), 336-341.
- Zan, R.ve Pietro, M. (2007). Attitude toward mathematics: Overcoming the positive/ negative dichotomy. The Montana Council of Teachers of Mathematics. *The Montana Mathematics Enthusiast, Monograph 3*, 157-168.

ÖĞRETMEN ADAYLARININ, TAMSAYI TARİFİNDE ÇOCUKLARIN NEREDE VE NEDEN KARIŞIKLIK YAŞADIKLARINA DAİR DÜŞÜNCELERİ

PROSPECTIVE TEACHERS' IDEAS ABOUT WHERE CHILDREN ARE CONFUSED AND WHY: THE CASE OF DESCRIBING INTEGERS

Ayşenur KUBAR
Middle East Technical University
akubar@metu.edu.tr

Erdinç ÇAKIROĞLU
Middle East Technical University
erdinc@metu.edu.tr

ÖZET: Bu çalışmada araştırmacıların amacı öğretmen adaylarının, ilköğretim öğrencilerinin tamsayı tarifi hakkındaki alternatif anlayışları ve hatalarını ve bunun nedenlerine dair güncel bilgilerini keşfetmektir. Çalışmanın verisi 201 – 2011 akademik yılı sonunda 38 Türk öğretmen adayından toplanmıştır. Bir durum çalışması deseni kullanılmıştır. Veriler, açık uçlu bir soru ile toplanmıştır. Çalışmamızın verileri, öğretmen adaylarının çeşitli alternatif kavramları ve hataları önerdiğini göstermiştir. Bu alternatif kavram ve hataların neden kaynaklandıklarına ilişkin ise öğretmen adayları, öğrencilerin sayı kümesi hakkındaki önceki bilgilerinin olumsuz aktarımı, öğrencilerin genel yetersizliği ve öğretim yaklaşımını önermişlerdir. Öğretmen adaylarının bu tür bilgi birikimlerini dikkate alarak ders tasarlayacakları düşünüldüğünde, alternatif kavram ve hataları belirlemelerinin önemli olduğu söylenebilir. Ancak, bu alternatif kavram ve hataların herbirinin birkaç katılımcı tarafından önerildiği düşünüldüğünde, öğretmen adaylarının bu konuda daha donanımlı hale gelmesine ihtiyaç olduğu söylenebilir.

Anahtar sözcükler: Kavram tanımı, öğretmen adayları, öğretmen bilgisi, tamsayılar, kavram yanılgıları

ABSTRACT: In this study, the researchers attempted to explore prospective teachers' current knowledge about elementary students' alternative conceptions and errors while they are describing integers and their reasons of why elementary students have such conceptions and errors. Data were collected from 38 Turkish prospective teachers at the end of 2010 – 2011 academic years. A case study design was used. Data were collected through an open-ended question. The data of our study indicate that prospective teachers suggested varied alternative conceptions and errors and the conceptions and errors are derived from students' negative transfer of former knowledge on number sets, students' general insufficiency, and the teaching approach. Being capable of suggesting them is important that prospective teachers design their lessons considering such background knowledge. However, each of them is suggested by few participants that in this regard prospective teachers need to become better equipped.

Key words: Concept definition, prospective teachers, teacher knowledge, integers, misconceptions

BİLİŞİM TEKNOLOJİLERİ VE YAZILIM DERSİ PROGRAMININ ÖĞRETMEN GÖRÜŞLERİNE GÖRE DEĞERLENDİRİLMESİ (KONYA-EREĞLİ ÖRNEĞİ)

Yakup YILMAZ

Teknolojide yaşanan gelişmeler ile birlikte öğretim-öğrenme teknolojileri bilim dalı olarak karşımıza çıkmaktadır. Mevcut gelişmeler ışığında yeniden yapılandırılan bilişim teknolojileri ve yazılım dersi programı bilgi okuryazarlığı, teknoloji kullanımı ve üretiminde etik değerler, estetik, gizlilik, bilgi güvenliği ve siber suçlar gibi kişisel ve toplumsal açıdan önemli olan konuları içine alacak biçimde yeniden oluşturulmuştur. Buna göre Milli Eğitim Bakanlığı (MEB) Talim Terbiye Kurulu Başkanlığı, yeni bir “Bilişim Teknolojileri ve Yazılım Dersi Öğretim Programı” hazırlamıştır. 2012 yılında yürürlüğe giren bu program ile ilgili olarak Konya ili Ereğli ilçesinde ortaokullarda görev yapan bilişim öğretmenlerinin yeni program hakkındaki görüşleri alınarak değerlendirilmiştir.

Anahtar Kelimeler: Bilişim Teknolojileri ve Yazılım Dersi, Öğretmen Görüşleri, Program

oooooooooooooooo

BİLİŞİM TEKNOLOJİLERİ VE YAZILIM DERSİ PROGRAMININ ÖĞRETMEN GÖRÜŞLERİNE GÖRE DEĞERLENDİRİLMESİ (KONYA-EREĞLİ ÖRNEĞİ)

Yakup YILMAZ

In conjunction with improvements in technology, learning and education technology is appeared as a discipline. Information technologies and software lesson program reconstructed under current improvements have been reformed as including personally and socially important subjects like information literacy, ethics in technology usage and production, aesthetics, privacy, information security and cybercrime. Accordingly, Milli Eğitim Bakanlığı (Ministry of Education) Talim Terbiye Kurulu Başkanlığı prepared “Information Technology and Software Lesson Instruction Program”. In terms of this program issued in 2012, IT instructors’,in secondary schools in Ereğli, Konya, reviews of about new program is assessed.

Keywords: Information Technology and Software Courses, Teachers Opinions, Program

HOW WELL PREPARED MATHEMATICALLY ARE OUR ENGINEERING STUDENTS WHO TRANSFER FROM AN ORDINARY DEGREE INTO AN HONOURS DEGREE SUBJECT: TECHNOLOGY EDUCATION

Michael Carr

Marisa Llorens

Susan O 'Shaughnessy

Brian Bowe

Domhnall Sheridan & Sheryl Sorby.

Dublin Institute of Technology, Bolton St., Dublin 1, Ireland

ABSTRACT: Students who have received a C3 (55%) or higher in Higher level mathematics in the Irish Leaving Certificate (the terminal secondary examination in Ireland) may enter directly onto a 4-year Honours degree in engineering. Students who have not achieved this level of mathematics have the option of entering onto a 3-year Ordinary degree (Level 7). Upon completion of this students may progress to the third year of the Honours degree. Relatively little work has been done on the transition (articulation) from an Ordinary degree to an Honours degree and in particular the mathematical preparedness of these students. In the third and fourth year of many Honours engineering courses within the DIT it is not unusual to have 30-50% of the students coming from an Ordinary degree background. The majority of these students come from within the DIT while others transfer in from other Institutes of Technology in Ireland. Previous work has shown that students from an Ordinary degree background are more than twice as likely to fail mathematics in their third year of the Honours degree when compared with students who have proceeded directly through an Honours degree programme. In this study we analyse students' performance across all subjects and examine if there is a relationship between mathematical performance in the final year of the Ordinary degree and overall performance across all subjects in the third and fourth year of the Honours degree. In addition, a similar comparison is made with these students mathematics grade on entry to first year and whether this is a determining factor in their success in the in the Ordinary degree and their ability to transfer to the Honours degree.

Keywords: Engineering Mathematics, Honours degree

INTRODUCTION

There are two distinct routes to an Honours degree (Level 8) in engineering in the Dublin Institute of Technology (DIT). Students with a C3 (55%) or higher in Higher level mathematics in the Irish Leaving Certificate (the terminal secondary examination in Ireland) may enter directly onto a 4-year Honours degree. Students who have not achieved this level of mathematics but have a pass in ordinary level mathematics may enter onto a 3-year Ordinary degree (Level 7). Students who successfully complete this award may apply to progress to the third year of the Honours degree. Up until relatively recently an upper merit (60%) was the minimum required to make this transition. In recent years this requirement has been relaxed with many students with lower marks being offered the possibility of transition upon successful completion of an interview.

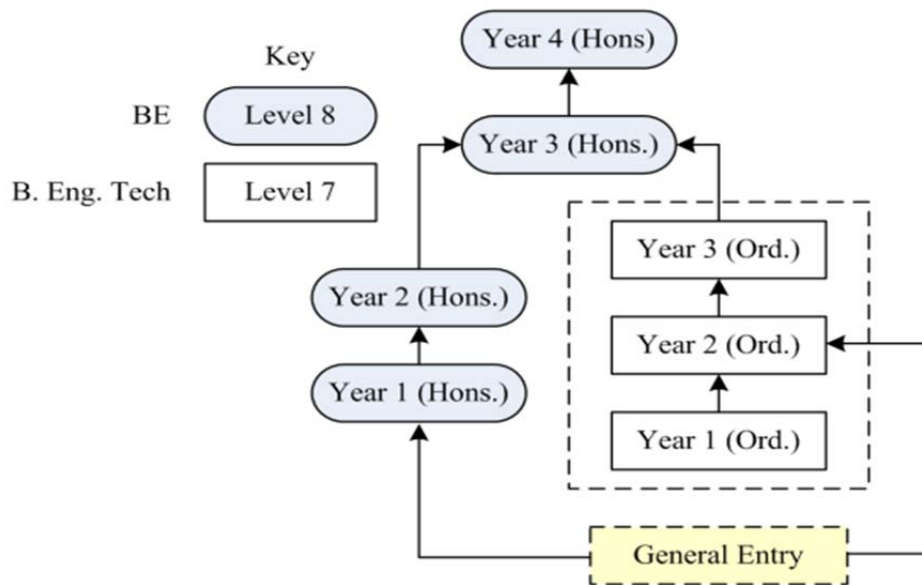

Figure 1: Schematic of the alternative routes to an Honours degree in Engineering in Ireland

Previous work has shown that students from an Ordinary degree background are more than twice as likely to fail mathematics in their third year of the Honours degree when compared with students who have proceeded directly through an Honours degree programme (Carr 2013). In this study we examine the performance of the group of students from the Ordinary degree in mechanical engineering who entered the third year of the honours programme in 2007 and 2008 and who subsequently graduated in 2009 and 2010 respectively.

RESULTS

2009 and 2010	Direct Entry to level 8	Entry via Level 7 course
N	85	33
Average mark (Standard deviation)	53.4(18.8)	62.1(8.1)
Number with grade of more than 60%	37/85	27/33
Graduated on time(Complete pass)	62/88	32/33

Table 1: Comparative Performance Of Students Who Transfer Onto An Honours Degree Programme And Those Who Enter Directly From Secondary School

In table 1 above we show a combined analysis for the combined mechanical engineering classes of 2009 and 2010. There were a total of 85 students who graduated who came from an Honours degree background i.e they had entered the course directly from secondary school. In contrast 33 students graduated who had entered the Honours degree programme after having completed the 3 year Ordinary degree. The average mark of the direct entry students was 53.4 % with a standard deviation of 18.8. In contrast the students who had entered via the ordinary degree had an average of 62.1% with a standard deviation of 8.1%. A two sample t-test was applied to this data and the average mark of the Ordinary degree students was found to be significantly different with $p=0.000$.

In addition we measured the proportion of students who achieved a 2.1 degree or higher. Of the direct entry students 37/84 achieved a 2.1 degree or higher in comparison with the ordinary degree students where 27/33 achieved a 2.1 degree or higher. This difference was found to be significant using two proportion test ($p=0.000$) and the Fisher exact test ($p=0.000$).

Of the students who entered from the ordinary degree background 32/33 graduated on time in comparison with 62/88 who had come through the direct entry route. Again this is significantly different using both the two proportion test($p=0.000$) and the Fisher exact test($p=0.002$)

Maths results

The original motivation for this study was the failure rate in the 3rd year Honours mathematics module. We now show the performance of these students in the mathematics module.

Results for the 2009 and 2010 graduating class

Correlation Coefficient(R^2)	3 rd Level 8 maths R^2 (p value)	4 th Level 8 Maths (p value)	4 th Level 8 Overall (p value)
3 rd year Level 7 Maths	0.139(0.454)	0.533(0.001)	0.57(0.001)

Table 2: Correlation Between 3rd Level 7 Maths Grade, 3rd Level 8 Maths Grade, 4th Level 8 Maths Grade And 4th Year Level 8 Overall

What we see here is little or no correlation between the 3rd year level 7 maths grade and the third year level 8 maths grade with a correlation coefficient of $R^2=0.139$ and $p=0.454$. This is rather worrying. But when we look at the relationship between the 3rd year level 7 maths grade and the 4th year level 8 grade we see a strong correlation ($R^2=0.57$), that is highly significant ($p=0.001$). We are also seeing a strong relationship between the 3rd year level 7th maths grade and their overall performance in the 4th year ($R^2=0.57$, $p=0.001$).

Maths grade as a predictor of success.

Given the strong correlation we see between the maths grade and the overall grade in fourth year should we use the 3rd year Level 7 maths grade to select students for entry onto the honours programme. In this section we compare whether we should use the overall 3rd Level 7 average grade, 3rd year Level 7 maths grade or the 3rd year Level 7 project grade. We see from table 3 below that the 3rd year level maths grade is as good a predictor of overall success in the honours degree as the 3rd year level 7 overall grade.

Correlation Coefficient(R^2)	3 rd Level 7 maths R^2 (p value)	3 rd Level 7 Overall (p value)	3 rd year Level 7 project (p value)
4 th year Level 8 overall	0.57(0.001)	0.585($p=0.000$)	0.308($p=0.08$)

Table 3: Correlation between overall 4th year performance, 3rd year level 7 maths grade, 3rd year level 7 overall grade and 3rd level 7 project mark

CONCLUSION

Several researchers in the U.S. have identified a phenomenon known as “transfer shock” (Cejda, 1994; Lanaan, 2001; and Hills, 1965). Through transfer shock, community college students who transition to a university typically experience a drop in grades for the first semester or two immediately after transfer. Grade point averages will typically recover by the time that students graduate and the dip in grades is typically attributed to the effort it takes to transition from one educational setting to another. We seem to be observing a similar phenomenon in the DIT, whilst there is a temporary dip in the performance of transfer students in the first semester these student quickly recover and there is a very strong correlation between their performance in the ordinary degree and their final performance. The American literature recommends that well-defined articulation agreements between the community college and the university as being critical to transfer student success. At DIT, the faculty teaching the ordinary and honours programs are typically in the same department and, in fact, most faculty teach in both programs. Thus, it appears that conditions are ripe at DIT for successful transition of students between the programs.

In addition we have noticed that these transfer students are outperforming their direct entry comparators, both in overall grade and the percentage who complete the course on time. Further work is required in this area and we hope to follow up this work with focus groups of students who have articulated in the past, along with a focus group of staff who have taught these students on both the ordinary and honours programmes.

REFERENCES

- Carr, M., Ni Fhloinn, E., & Bowe, B. (2013). Core skills assessment to improve mathematical competency, *European Journal of Engineering Education*, pp1-12
- Carr, M., Ni Fhloinn, E., Murphy, E., & Bowe, B. (2013). Addressing continuing mathematical deficiencies with advanced mathematical diagnostic testing. Carr, M., Ni Fhloinn, E., Murphy, E., & Bowe, B. *Teaching Mathematics Applications* 32 (2): 66-75.
- Cejda, B. D. (1994). Reducing transfer shock through faculty collaboration: A case study. *Community College Journal of Research and Practice*, 18, 189-199.
- Hills, J.R. (1965). Transfer shock: The academic performance of junior college transfer. *Journal of Experimental Education*, 33, 201-215.
- Lanaan, F. S. (2001). Transfer Student Adjustment. *Transfer Students: Trends and Issues. New Directions for Community Colleges, Number 114. The Jossey-Bass Higher and Adult Education Series*, pp. 5-13.

AN EVALUATION ABOUT TEACHER TRAINING PROGRAMS: FROM THE PERSPECTIVE OF PRESERVICE TEACHERS

Gülçin OFLAZ
Cumhuriyet University
erengulcin3@hotmail.com

Duygu ALTAYLI
Cumhuriyet University
duygu.altayli87@hotmail.com

ABSTRACT: The aim of this study is to explain the preservice primary mathematics teachers' reasons of preferring this department and to define their opinions about mathematics and mathematics teaching lessons. For this reason it has been worked with 40 preservice teachers who are seniors at a state university's Department of Primary Mathematics Education. In this study, in which qualitative research approach has been applied, the data is gathered by a questionnaire form including open-ended questions. Preservice teachers are asked their reasons of choosing this department, their ideas about ideal university lecturers, their opinions about mathematics and mathematics teaching lessons, their suggestions about teaching process. The data gathered from the answer sheets has been analyzed by content analysis technique. Most of the students have chosen this department because of their love of mathematics. They have stated that they won't use mathematics lessons in their professional life but still mathematics lessons are important for thinking in mathematical way. On the other hand, they have stated that mathematics teaching lessons have got great importance in their professions.

Key words: Preservice primary mathematics teacher, mathematics lessons, mathematics teaching lessons

INTRODUCTION

One of the main items of education system is the teacher who is applier of the process. The training quality on professional view shows the quality of his/her teaching presentation (Seferoğlu, 2004). It can be seen that the preservice teachers take field courses and field teaching courses together with training courses. When investigating the literature on teacher training, it can be seen that the works on this subject are generally about school experiments but very less of them are about their ideas and opinions on university training programmes (Dursun&Kuzu, 2008; Tüfekçi Aslım, 2013; Sezgin Nartgün, 2008; Yıldırım, 2013; Eraslan, 2008; İnal&Büyükyavuz, 2013; Mete, 2013; Sarıtaş, 2007; Baştürk, 2011; Memduhoğlu&Topsakal, 2008, Eraslan, 2009). So, the aim of this work is to explain the preservice primary mathematics teachers' reasons of preferring this department and to define their opinions about mathematics and mathematics teaching lessons

METHODOLOGY

Preservice teachers are asked to evaluate their university education. So, the research which has been held with the qualitative methodology is a survey study. Survey study is an approach that aims describing a state as it is and collecting detailed data (Karasar, 2006).

Participants

This research has been applied to 40 seniors at Department of Primary Mathematics Education of a state university. It is applied to seniors because the students need to take all the lessons, the mathematics lessons and the formation lessons in order to make correct evaluations.

Instruments

The data has been gathered by a questionnaire form consisting open-ended questions. The questions asked to the participants are classified under the title of participants' reasons of choosing the Department of Primary Mathematics Education, the qualities of ideal lecturers, opinions about mathematics lessons and mathematics teaching lessons, suggestions about the process.

Analysis of data

The data have been analyzed using the content analysis technique of qualitative research method. The answers of the preservice teachers have been categorized as preference reasons of their department, their opinions about an ideal lecturer, their opinions about mathematics lessons and mathematics teaching lessons, their suggestions about the process. NVivo 8 programme has been used on analyzing data. The programme gave the opportunity of being close to the data and revising-arranging the categories (Kuş, 2007). The analysis of the data has been held by two researchers on this field at the same time. There has been a consensus on the codes and the categories formed.

FINDINGS

The answers given to the questions by the preservice teachers have been categorized under 5 titles. Each category will be examined by a model and citations of participants will take place in this part of the research. Frequencies of each category are given together with models in parentheses.

Preservice Teachers' Reasons Of Choosing Department Of Primary Mathematics Education

We can find 4 sub-categories under the category of “reasons of choosing Teaching Mathematics”. These 4 sub-categories can be gathered under these subtitles: love [love of teaching (5 participants), love of teaching maths (2), love of learning maths (3), love of maths (18), love of previous maths teacher (5), love of children (4)], factor of parents (3), dream of childhood (5), features of profession [(advantage of having additional marks at university entrance exam (3), requiring less mark at university entrance exam (8), being a non-stressed job (3), having a job easily (4)]

Model 1: The reasons of choosing the department of primary mathematics education

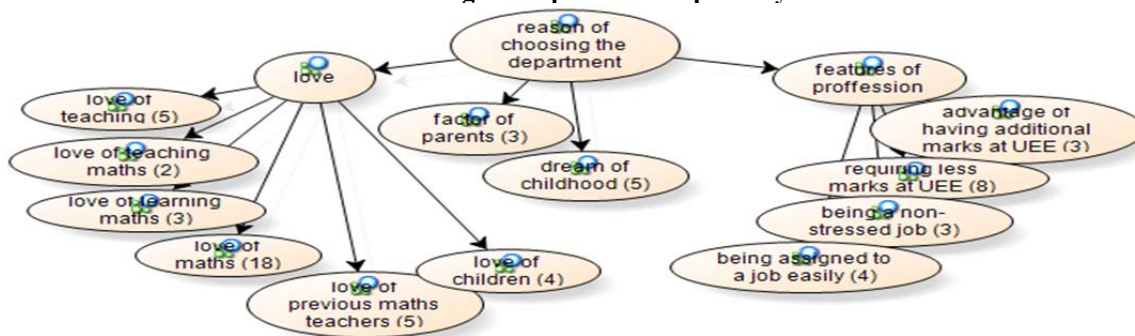

Some quotes of preservice teachers:

Preservice Teacher (PT) 31: *Primarily, I love mathematics; I believe teaching mathematics is more exciting than understanding it...*

PT 33: *I wanted to be secondary mathematics teacher but my father wanted me to be primary mathematics teacher. Both include mathematics so it doesn't matter which one.*

PT14: *My main goal was pharmacy but the mark I had at the university entrance exam was equal to primary mathematic teaching...*

Most of the participants chose the primary mathematics education because they love mathematics. As expressed on PT 31, some chose this department because they both love mathematics and teaching mathematics. When examining the model, reasons that made them choose the primary mathematics education are the love of being teacher, the love of teaching mathematics, the love for their own mathematics teachers and being the their childhood dream.

Also we can say that parents are effective in choosing this department when examining the answers. PT 33's answer supports this conclusion. Some participants state that this job was their dream. As PT14 says, there are students who chose this department depending on their results of the university exam. In addition, there are preservice teachers who chose this department because of having additional point advantages, being an easy job for women and being easy to be assigned.

Opinions About Ideal University Lecturers

When examining the answers, we formed 2 sub-categories for “opinions about ideal university lecturers”. they are: personality [(disciplined (4 participants), respectful(5), time waster (1), communicative (6), gentle (7),

happy (2), not bossy (2), practical (1), funny (2), exciting (6), lovable (2), sociable (2), decisive (1)] and professional [(progressive (6), idealistic (3), knowledge loving (5), expert on field (7); about teaching: fair (5), using technology(2), student-based (3), exercise-based (12)]

Model 2: Opinions about ideal university lecturers

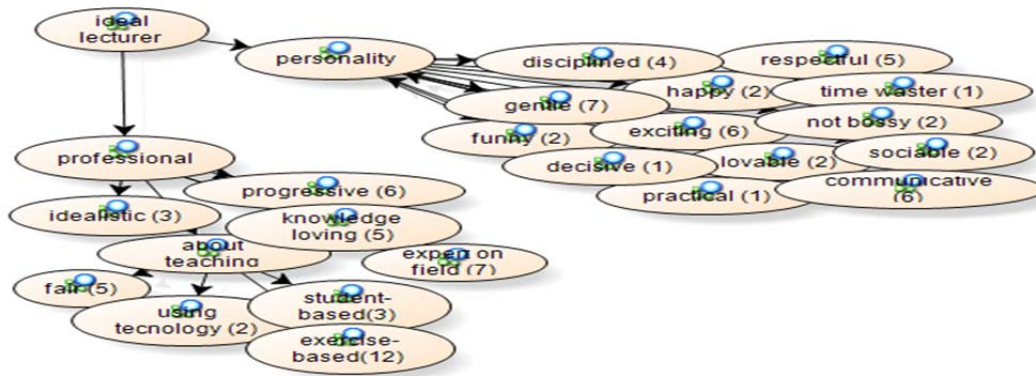

Some quotes of the preservice teachers:

PT 7: *First of all I want to communicate with a lecturer... We can't keep in touch with lecturers, we can't even ask questions... Yes, they should be disciplined but I must feel that I'm important too.*

PT 24: *...Lecturers should be well equipped and I should use what I have learnt... I think, lecturers should be equipped with mathematical knowledge.*

PT 29: *I thought that I will be a mathematician and I will participate the mathematical proofs when I came to this department. So, our lecturers should provide this...*

As we can see, an ideal lecturer should spend time to students, communicate with them and also love them, gentle and also disciplined, respectful, happy, not bossy, practical, funny, exciting, social and decisive. PT7's answer supports this finding. On the other hand, preservice teachers have stated that an ideal lecturer should be an expert on his/her field, progressive, idealistic, learner based, should let students apply what they have learnt, should be technology user and fair. As stated by PT 24 and PT 29, a lecturer should be well equipped with mathematical knowledge and should be progressive on his/her field. As understood from the frequencies of the categories, the participants have given more importance to professional qualities. According to this finding a lecturer is the one who is full of mathematical knowledge and continuously worker on progressing his/her knowledge.

Opinions About The Mathematics Lessons

We have created 3 sub-categories for the category of "Opinions about the mathematics lessons" after analyzing the preservice teachers' answers. These categories are: negative [(just passing the class (5 participants), difficult (13), not related with real life (2), only for academically career (3)]; positive [(problem solving ability (8), proving ability (17), reasoning efficiently (15), enjoying learning mathematics (8), more meaningful after the field exams at "public personnel selection exam" (3), basic lessons for this department (5)] and usage in profession [(will use it (2), will never use it (20), will partly use it (7)].

Model 3: Opinions about the mathematics lessons

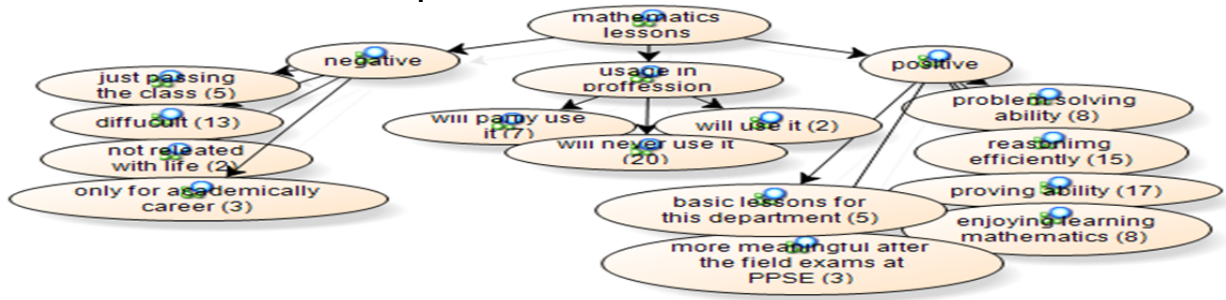

Quotes of some preservice teachers:

PT 7: *I still can't understand analysis and differential equations and can't solve them. How can I use them in my professional life? This is faculty of education, not engineering or science...*

PT 15: *I'm thankful to my lecturers but I don't think I will apply these lessons at my professional life. I think those who have academically goals should take these lessons and us who want to teach mathematics at village should not take so much difficult lessons...*

PT 27: *Surely, my mathematical perspective has developed here with these lessons but I don't think I'm going to use this knowledge in my professional life. For example, it's obvious that I'm not going to say "you can memorize more easily if you take it's integral according to $\ln x$ " to a student who has problem in memorizing time table.*

As seen on the model, preservice teachers state that the mathematics lessons have made them think more analytically, made them understand the basis of mathematical expressions, and enjoying dealing with mathematics and they state that they give more importance to these field classes after the PPSE Field Exam. PT 27's answer supports this finding. On the other hand, most of the participants state that they take these lessons just to pass to next grade, that the lessons aren't related with daily life and that the contents of the lessons are so difficult that they can't apply them on their professional teaching process. PT 7, PT 15 and PT 32 have expressed this finding at their citations. However, while two participants say that they will use this knowledge in his/her teaching process, 20 of the participants state that they won't use this knowledge in professional teaching process.

Opinions About Mathematics Teaching Lessons

We have created 3 sub-categories for the category of "Opinions about mathematics teaching lessons" after analyzing preservice teachers' answers. These are: student [(how it can be taught better (12 participants), attracting attention of students easily (3), student-based teaching(6)], teaching [(using different techniques (5), using computers during teaching (3), making mathematics more significantly (4), using history of mathematics (3), using materials (5)], teacher [(making me feel like a teacher (6), making me love my job more (6), increases my self-confidence (2)].

Model 4: Opinions about mathematics teaching lessons

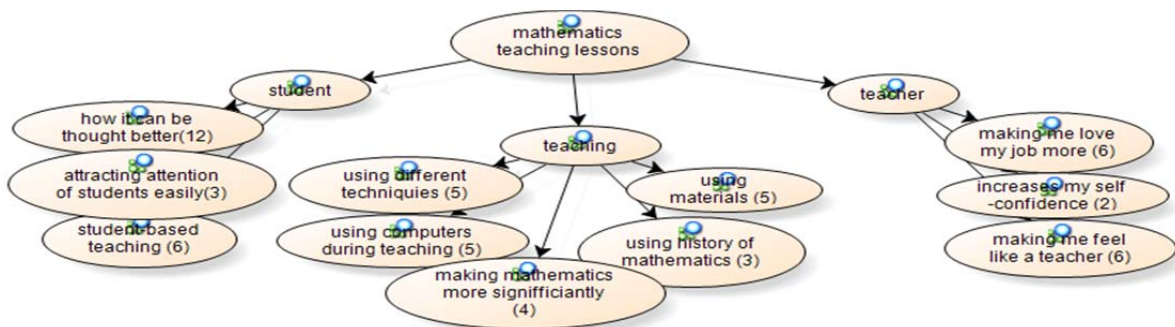

Some citations of preservice teachers:

PT 32: *I need to know how to teach the expression of “minus times minus equals to plus”...*

PT 18: *These lessons were about “how to teach” ...also, these lessons made me feel like a teacher, I realized that I can teach with pleasure...*

PT 34: *These are the only lessons that I’m fond of and useful for me. Because the content of our professional life went into shape by these lessons. Thanks to these lessons, we have learnt how to teach, how our students can learn better, what mistakes our students can make...*

As we can see on the model, preservice teachers stated that their self-confidence has shown up and that they love their profession more with the help of mathematics teaching lessons. In addition, with the help of these lessons they state that they have learnt to teach the way they learn themselves, to use the appropriate material, to make mathematics more abstractive, to attract their students’ focus and to be student-based. We can support these findings with the citations above.

Suggestions On The Teaching Process

There are 3 sub-categories under the category of “suggests on the teaching process”. They are: teaching practices [(1 year of examining, 1 year of teaching practices (3 participants), increasing hours of teaching practices (12), teaching practices every year (4)]; increasing university-school cooperation (3); content [(should be more practical (10), should be decreased to primary school level (2), there should be less theoretical lessons (3), should make student sociable (4), more mathematics teaching lessons (5)].

Model 4: Suggestions on the teaching process

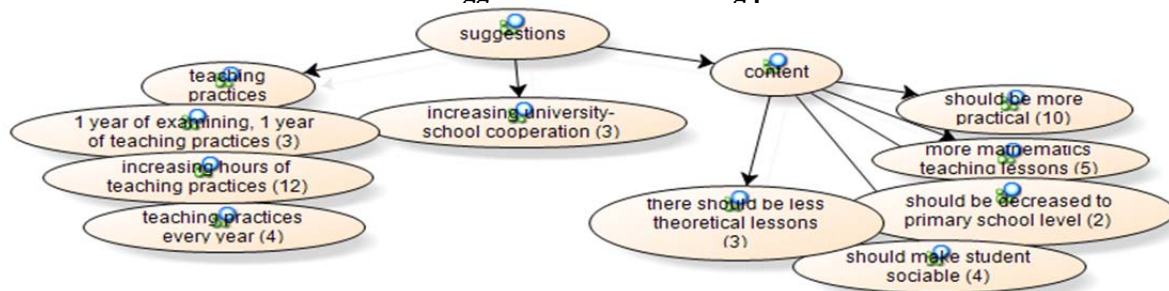

Quotes of some of preservice teachers:

PT 32: *Instead of making students tired of theoretical lessons and making them dislike their job, you should teach them what being a teacher means and how to be a better teacher. Because limits, integral or derivatives don’t solve the problems of primary school students.*

As we can see on the model, preservice teachers want more mathematics teaching lessons in order to be a better teacher. PT 32’s answer supports this outcome.

CONCLUSION

The preservice primary mathematics teachers’ opinions about the reasons of choosing this department, about the mathematics lessons, about mathematics teaching lessons, about an ideal university lecturer and the suggestions about the teaching process are determined in this study. As stated before, it can be seen that love of (mathematics, mathematics teaching, eg.) is the most important reason in choosing this department. Most of the students have chosen this department because they love mathematics. The features of working as a mathematics teacher have been a reason of choosing the department too.

The students have focused on the professional side of an ideal lecturer more. On their view, a lecturer is well equipped, hardworking and contributing. They expressed that they will not use knowledge they gained at the mathematics lessons, though these lessons have improved their mathematical background. They told that mathematics teaching lessons have great importance in their professional life and they have gained self-confidence thanks to these lessons. The preservice teachers have suggested that teacher training lessons should be increased and mathematics teaching lessons should take more places instead of mathematics lessons.

SUGGESTION

When paying attention to preservice teachers' thoughts, some precautions can be created to make mathematics lessons to be more meaningful for students. For example, we can try to make students get rid of the idea of "these lessons are not useful" by real-life teaching techniques and telling them how to apply these knowledge in their professional life. We can provide the class environment of using what they have learnt previously and the environment of actively participating during the lessons. Also we can give the opportunity of doing more teaching practices by letting them teach more.

REFERENCES

- Baştürk, S. (2011). Mathematics Teacher Candidates' Evaluations Of Teaching And Learning Process In Faculty Of Education. *Uluslararası İnsan Bilimleri Dergisi*, 8:1. Available at: [Http://www.insanbilimleri.com](http://www.insanbilimleri.com)
- Dursun, Ö. Ö.& Kuzu, A. (2008). Opinions Of Teacher Candidates And Supervisors Regarding Problems Experienced In Teaching Practice. *Selçuk Üniversitesi Ahmet Keleşoğlu Eğitim Fakültesi Dergisi*, 25, 159 -178,
- Eraslan, A. (2008). Faculty–School Partnership Programme: Prospective Mathematics Teachers' Reflections On School Practice Course. *Hacettepe University Journal Of Education*, 34: 95-105.
- Eraslan, A. (2009). Prospective Mathematics Teachers' Opinions on 'Teaching Practice'. *Necatibey Faculty of Education Electronic Journal of Science and Mathematics Education*, Vol. 3, Issue 1, June, pp. 207-221.
- Inal, S.&Büyükyavuz, O. (2013). English Trainees' Opinions on Professional Development and Pre-Service Education. *Hacettepe University Journal Of Education*, 28(2), 221-233.
- Karasar, N. (2006). *Bilimsel Araştırma Yöntemi*. Ankara: Nobel Yayın Dağıtım.
- Kuş, E. (2007). *Nitel-Nitel Araştırma Teknikleri*. Ankara: Anı Yayıncılık.
- Memduhoğlu, H. B., Topsakal, C. (2008). Quality and Problems of Teacher Education Graduate Programs According to the Views of Students and Faculty Members. *Ege Eğitim Dergisi*, (9) 1: 95–129.
- Mete, Y. A. (2013). Metaphors of Prospective Teachers, Teachers, and School Principals for Sarıtaş, M. (2007). Okul Deneyimi I Uygulamasının Aday Öğretmenlere Sağladığı Yararlar Konusundaki Görüşlerin Değerlendirilmesi. *Uludağ Üniversitesi Eğitim Fakültesi Dergisi XX* (1), 121-143.
- Seferoğlu, S. S. (2004). Öğretmen yeterlikleri ve mesleki gelişim. *Bilim ve Aklın Aydınlığında Eğitim*, 58, 40-45.
- Sezgin Nartgün, Ş. (2008). Candidate Teachers' Views On The Criteria Of Appontment To Ministry Of National Education Institutions. *Abant izzet Baysal Üniversitesi Eğitim Fakültesi Dergisi*, Vol:8, No:2. The Practical Training Course. *Journal of Teacher Education and Educators*, Volume 2, Number 2, 249-274.
- Tüfekçi Aslim, s. (2013). Evaluation Of The Attitudes Of Candidate Elementary Teachers To The Profession Of Teaching. *Gazi Üniversitesi Endüstriyel Sanatlar Eğitim Fakültesi Dergisi*, 32, 65-81.
- Yıldırım, A. (2013). Teacher Education Research in Turkey: Trends, Issues and Priority Areas. *Education and Science*, Vol. 38, No 169.

EVALUATION OF ALGORITHM IMPLEMENTATION ASSESSMENT METHODS BASED ON A DATA STRUCTURE COURSE

Kamil Yurtkan
Cyprus International University
kyurtkan@ciu.edu.tr

Cagin Kazimoglu
Cyprus International University
ckazimoglu@ciu.edu.tr

Umut Tekguc
Cyprus International University
utekguc@ciu.edu.tr

ABSTRACT: Implementing algorithms and making abstractions are two integral parts of computer programming. Algorithm implementation process involves understanding a business problem, designing the most appropriate solution and abstracting this in a programming environment. Thinking within the syntax of a programming language and generating algorithms simultaneously are often found challenging by students. More importantly, majority of students do not necessarily understand the underlying reasons behind the multiple assessment methods used in the evaluation of algorithm implementation. Some students believe that the theoretical measurements for algorithm implementation are not directly related to the practical development of solutions and hence, they do not see the point of theoretical exams particularly in algorithm implementation process. In this paper, we analyze the methodologies used for the evaluation of algorithm implementation. The Data Structures and Data Organization course taught at the Faculty of Engineering in Cyprus International University (CIU) has been selected as a pilot course to perform a rigorous study in order to compare the theoretical and the practical exam results of students. The aim of the study was to understand whether or not there was a significant relationship between the theoretical and practical exam results. The raw data of the study came from 100 students who were randomly selected without considering their previous background or programming knowledge. The correlation between students' programming capabilities and their theoretical knowledge were analyzed in order to state whether or not their performance in theoretical exams are authentic when compared to their practical exams.

Key words: Algorithm implementation, programming assessment, assessment methodologies, data structures, c programming.

INTRODUCTION

Majority of institutions in the Cyprus follow a common academic grading system which offers the options of using quizzes, theoretical exams (e.g. written exams), practical exams (laboratory exams), oral exams and/or project development as major knowledge assessment methods. The variation of the academic grading system provides academicians flexibility in measuring students' knowledge and skills both in theory and in practice. Despite a rich variation in the academic grading system provides many advantages, it also brings considerable problems as the balance among the assessment methods might be diverse. As multiple assessment methods are used to measure students' ability and knowledge, it is arguable whether or not those students who did well in the theoretical exams would also do well in the practical exams. Although this is a generic problem in academy, we have observed that a number of students are suffering particularly in algorithm development courses as they believe the theoretical part of algorithm development is independent from practical solution development. Furthermore, various studies discussed these issues and offered new instructional design and assessment methods in order to measure students' ability and knowledge in computer algorithms accurately. (Ala-Mutka, 2005; Barros *et al.*, 2003; Chamillard & Braun, 2000; Daly & Waldron, 2004).

In this study, we focus on the evaluation of assessment methods for an algorithm implementation course particularly the "Data Structures and Data Organization" course taught in the 5th semester of Computer Engineering, Information Systems Engineering and Management Information Systems departments of Cyprus International University (CIU).

The rest of the paper discusses a) a rigorous study and its objective; b) the methods used in the statistical analyses of the rigorous study; c) distribution of data and d) the statistical results along with their discussion. The paper concludes with future work based on the statistical results obtained.

A RIGOROUS STUDY AND ITS OBJECTIVE

A rigorous study was undertaken to measure the correlation between the assessment methods used in measuring students' knowledge in an algorithm implementation course particularly the Data Structure and Data Organization course thought at CIU. The study had two main purposes. Firstly, it was aimed to investigate whether or not the practical exams and theoretical exams were genuinely evaluating students' knowledge at the same level of accuracy in terms of programming and algorithm implementation. Secondly, it was aimed to analyze the correlations between the algorithm development projects and the theoretical exams. As a result of this, it was intended to investigate whether or not the results of the theoretical exams were correlated with the results of the practical exams.

EXPERIMENTAL BACKGROUND

The study is performed using the IBM software package, SPSS, which is used for statistical analysis particularly in social studies. In order to perform the statistical analysis, a total of 100 students' exam/project results were randomly selected from the Computer Engineering, Information Systems Engineering and Management Information Systems Departments at CIU. As the students studied in different semesters, there had been some absence in their results due to a variety of reasons. Hence, only 84 valid responses were gathered in this study. The performances of the students in the theoretical exams were compared with the practical performances of the same students. The identities of the randomly selected students were kept confidential in order to provide an anonymous study.

Table I. Stack implementation questions contained in midterm exams of the semesters observed.

Semester	Stack Implementation Question
Fall 2011 - 2012	Q1) Write a function that takes 3 stacks, p, gr and ls , as arguments and updates the values of the two stacks gr and ls as follows. The stack gr contents are the elements of the stack p greater than or equal to 50 (≥ 50), and the stack ls contents are the elements of the stack p less than 50 (< 50).
Fall 2012 - 2013	Q1) Write a C/C++ function that performs search operation in the stack. If the search key is found, function should return 1 , else return 0 . Stack should preserve the contents after the search. Q2) Write a C/C++ function that takes 2 stacks, p and q , as arguments and derives the contents of q according to p such that if the element in p is greater than or equal to 10 , the corresponding element in q should be 1 , otherwise 0 .
Fall 2013 - 2014	Q1) Write a pseudo code to separate even and odd numbers and push them to different stacks. Q2) Write a C/C++ function that takes 2 stacks, p and q , as arguments and copies the contents of stack p to q .

As shown in Table 1, exam results were obtained from three different semesters which are 2011-2012, 2012-2013 and 2013-2014 Fall semesters. For each semester, two analyses have been performed. The first test was performed on stack implementation questions that were matched with a practical lab exam that involved a similar type of question (Table II). Consequently, the second test was performed between the midterm exam and the project which was then graded with an oral exam (Table III). The topics of the implementation questions were the stack implementation which is a well-known topic of data structures. Thus, despite being on different semesters, all midterm questions were based on the same subject. The theoretical and practical exams were all graded by pair reviews in order to keep a fair evaluation.

Table II demonstrates the questions asked to students in their practical exams as the result students obtained from these questions were used in the first test (i.e. comparing midterm exam results with practical exam results).

Table III demonstrates the question asked to students in their project. The results students obtained from this project were compared to stack implementation question results listed in Table 1. As shown from below, the project included implementations related to arrays and structures which then were tested with an oral exam. The questions asked to students in the project were matched with the midterm exam and the result students obtained from these were used in the second test.

Table II. Lab Final Exam questions asked to students at the end of the observed semesters.

Semester	Lab Final Question
Fall 2011 - 2012	<p>Q) Write the following function to print the content of stack and test with the given stack implementation.</p> <p style="text-align: center;">void printstack (struct stack * ps);</p>
Fall 2012 - 2013	<p>Q) Write the following function to find the size of stack and test with the given stack implementation.</p> <p style="text-align: center;">int sizestack (struct stack * ps);</p>
Fall 2013 - 2014	<p>Q) Write the following function to count even numbers of stack and test with the given stack implementation.</p> <p style="text-align: center;">int countevenstack (struct stack * ps);</p>

Table III. Sample project definition.

Sample Project Definition	
<p>Write a complete C or C++ program to implement a phonebook structure. Structure contains id, name, surname and phone number of a person. Your program should have the following menu. Write necessary functions for the menu:</p> <ol style="list-style-type: none"> 1- To add a person to phonebook 2- To delete a person from phonebook 3- To list data in the phonebook 4- To search for a record 5- To update phoneNo of a record 6- To sort according to ID 7- To quit 	<pre> struct phone_book { int ID; char name[20]; char surname[20]; char phoneNo[20]; }phone_list[100]; </pre>

DISTRIBUTION OF DATA

Figure 1 illustrates the distribution of data gathered from the difference of students' knowledge between the practical exam (i.e. lab final exam) and theoretical exam (i.e. stack implementation question). As it can be observed from the figure, the data came from a non-normally distributed population. The histogram has kurtosis issues as the observations are way over the normal distribution curve. Additionally, the histogram is skewed to the right which proves that the distribution of data is asymmetric. As a result, the histogram shows that the data came from a non-normally distributed population.

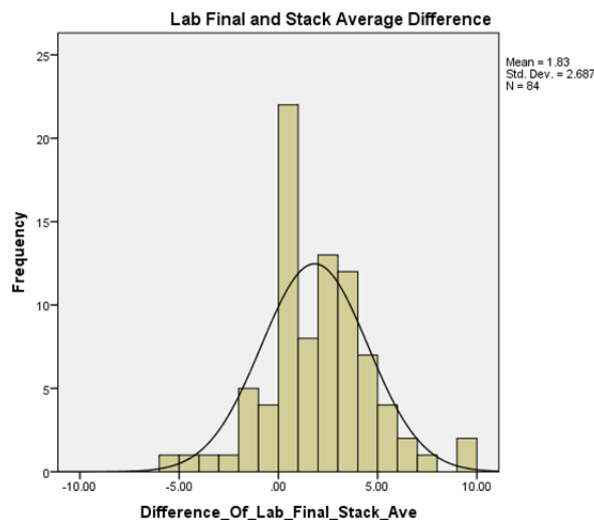

Figure 1. Data histogram showing the distribution.

Despite the fact that a histogram can provide a generic overview regarding the distribution of data, it is not a standalone reliable tool to measure the distribution of data. That is why, a Q-Q plot was generated in order to ensure regarding the distribution of data. As it can be observed from the Figure 2, the observations do not embrace the linear line on the Q-Q plot. The values at both ends are scattered and do not approach to the parallel line. Additionally, very few observations hug the linear line (i.e. the expected normal curve). This shows that the

data came from a non-normally distributed population and hence, the result of the Q-Q plot supports the findings of the Histogram.

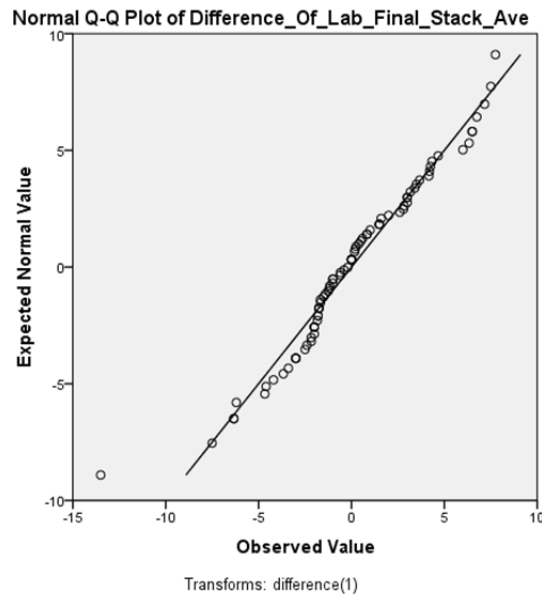

Figure 2. Quantile – Quantile (Q-Q) Plot.

RESULTS AND FINDINGS

As the results show that the data came from a non-normally distributed population, it is required to use the Spearman’s rank test in order to investigate the correlations between the student knowledge in test 1 (i.e. stack implementation question and lab final exam) and in test 2 (i.e. the midterm exam and the project implementation).

As shown in Table IV, the Spearman’s rank correlation coefficient regarding the first test was found to be significant and moderately strong ($r=0.636$; $p<0.001$). This means that, the students who performed well in the midterm exam for the stack implementation questions also did well in the lab final practical exam. As the correlation is found to be significant, modestly strong and positive, we have strong reasons to believe that the results of the algorithm implementation in the theoretical exams (i.e. midterm exam) are closely related to the results in practical exams (i.e. final exam). In other words, those students who solved stack implementation questions in the midterm exam also solved the same type of questions in the lab final exam.

Table IV. Correlations between stack implementation questions and lab final exams.

		Lab_Final	STACK_Ave
Spearman's rho	Correlation Coefficient	1.000	.636**
	Lab_Final Sig. (2-tailed)	.	.000
	N	84	84
	Correlation Coefficient	.636**	1.000
STACK_Ave	Sig. (2-tailed)	.000	.
	N	84	84

** . Correlation is significant at the 0.01 level (2-tailed).

Table V shows the Spearman’s rank correlation coefficient regarding the second test. As shown from the table, the correlation among the pair was found to be significant and modestly strong ($r=0.535$; $p<0.001$). Although this is not as high as the first tests’ coefficient, the correlation between the midterm exam and project is found to be significant, positive and moderately strong. This provides strong reasons to believe that those students who did well in the midterm exam also performed a similar performance in their projects.

Table V. Correlations between midterm exams and projects.

		Midterm	Project
Spearman's rho	Midterm		
	Correlation Coefficient	1.000	.535**
	Sig. (2-tailed)	.	.000
	N	84	84
	Project		
	Correlation Coefficient	.535**	1.000
Sig. (2-tailed)	.000	.	
N	84	84	

** . Correlation is significant at the 0.01 level (2-tailed).

CONCLUSION

The correlation between students' programming capabilities and their theoretical knowledge were analyzed on a data structure course. The results of the statistical analyses showed that there is a positive, significant and moderately strong correlation among the first test pair (stack implementation questions and lab final exams.) and the second test pair (midterm exam and project). In both cases, the results are similar, and therefore it is possible to conclude that the theoretical and the practical exams are related and assessing the same criteria. In other words, the statistical results provide strong reasons to believe that those students who have a theoretical understanding of algorithm implementation tend to have a good understanding in producing practical solutions through using algorithms. As future work, the finding of this study could be investigated further by conducting the study with a larger sample size. Although the sample size of this study (i.e. 84 valid responses) was enough to generate accurate results, a larger sample size could provide a more realistic and detailed distribution.

REFERENCES

- Ala-Mutka, K. M. (2005). A survey of automated assessment approaches for programming assignments. *Computer Science Education*, 15(2), 83-102.
- Barros, J. P., Estevens, L., Dias, R., Pais, R., & Soeiro, E. (2003, June). Using lab exams to ensure programming practice in an introductory prog. course. In *ACM SIGCSE Bulletin* (Vol. 35, No. 3, pp. 16-20). ACM.
- Chamillard, A. T., & Braun, K. A. (2000). Evaluating programming ability in an introductory computer science course. *ACM SIGCSE Bulletin*, 32(1), 212-216.
- Daly, C., & Waldron, J. (2004, March). Assessing the assessment of programming ability. In *ACM SIGCSE Bulletin* (Vol. 36, No. 1, pp. 210-213). ACM.

DİĞİTAL BOŞLUK: KIRSAL ALANLARDA GÖREV YAPAN SINIF ÖĞRETMENLERİNİN BİLGİ İLETİŞİM TEKNOLOJİLERİNİN KULLANIMINA İLİŞKİN GÖRÜŞLERİ

Şengül S. ANAGÜN

Nurhan ATALAY

21. yüzyılda, bilginin kapsamı, bilgiye erişim şekli ve hızı değişmekte, bilgiye erişimde yeni yollar ortaya çıkmakta ve bilgi ve iletişim teknolojileri (BİT) ilerlemektedir. BİT'lerin ilerlemesi doğrultusunda eğitim politikaları da değişmektedir. Dolayısıyla BİTlerin eğitimle bütünleştirilmesi, öğretmenler tarafından öğretme-öğrenme sürecinin her aşamasında etkili bir biçimde kullanılması, eğitim araç-gereçlerinin BİT'lerdeki gelişmelere paralel olarak yenilenmesi önemlidir. Böylece toplumdaki tüm bireylerin, BİT'leri kullanarak istediği bilgiye, bilgi yığınları arasından seçmeleri, daha kolay ve daha hızlı ulaşabilmeleri ve ulaştıkları bilgiyi günlük yaşamlarında kullanabilmeleri sağlanmış olur. Bireylerin BİT becerileri ile donanık olarak yetiştirilmesinde ister şehir ister kırsal alanda görev yapsın öğretmenlerin rolü büyüktür. Özellikle de kırsal alanda görev yapan öğretmenlerin öğrenme-öğretme sürecinde BİT'leri kullanması, öğrencilerinin BİT ile karşılaşmalarını ve kullanma becerilerine sahip olmalarını sağlaması toplumdaki digital boşluğun giderilmesi açısından önemlidir. Bilgi ve iletişim alanındaki olanaklar, kaynaklar ve erişim dağılımındaki eşitsizliği ifade eden digital boşluğun giderilmesinde kırsal alanlarda görev yapan sınıf öğretmenlerin rolü büyüktür. Bu bağlamda kırsal alanda görev yapan sınıf öğretmenlerin bilgi ve iletişim teknolojilerini sınıflarında kullanması ile ilgili deneyimlerinin, görüşlerinin ve yaşadıkları sıkıntılarının belirlenmesi, BİT'lerin öğretme-öğrenme sürecinde daha işlevsel olarak kullanılması ile ilgili olarak paydaşlara bilgi vermesi açısından önemlidir. Dolayısıyla bu çalışmanın amacı da kırsal alanlarda görev yapan sınıf öğretmenlerinin, BİT'leri bir öğretim aracı olarak kullanımı ile ilgili görüşlerini ve karşılaştıkları sorunlarının ortaya çıkarılmasıdır. Araştırmada, fenomenoloji yaklaşımından yararlanılmıştır. Fenomenoloji, katılımcıların deneyimlerini nasıl anlamlandırdıkları ve yorumladıklarını, yine katılımcıların algı ve açıklamalarına dayalı olarak, anlamaya çalışan nitel bir araştırma yaklaşımıdır. Araştırmanın katılımcıları amaçlı örnekleme türlerinden ölçüt örnekleme ile seçilmiştir. Araştırmaya kırsal alanda görev yapan 11 sınıf öğretmeni katılmıştır. Araştırmanın verileri, yarı yapılandırılmış görüşmeler ile toplanmıştır. Araştırmanın bulgularına göre kırsal alanda görev yapan sınıf öğretmenlerinin BİT'leri kullanımlarının, yeterli olmadığı sonucuna ulaşılmıştır.

Anahtar Kelimeler: BİT, kırsal alan, digital boşluk

oooooooooooooooooooo

DİĞİTAL BOŞLUK: KIRSAL ALANLARDA GÖREV YAPAN SINIF ÖĞRETMENLERİNİN BİLGİ İLETİŞİM TEKNOLOJİLERİNİN KULLANIMINA İLİŞKİN GÖRÜŞLERİ

Şengül S. ANAGÜN

Nurhan ATALAY

21. yüzyılda, bilginin kapsamı, bilgiye erişim şekli ve hızı değişmekte, bilgiye erişimde yeni yollar ortaya çıkmakta ve bilgi ve iletişim teknolojileri (BİT) ilerlemektedir. BİT'lerin ilerlemesi doğrultusunda eğitim politikaları da değişmektedir. Dolayısıyla BİTlerin eğitimle bütünleştirilmesi, öğretmenler tarafından öğretme-öğrenme sürecinin her aşamasında etkili bir biçimde kullanılması, eğitim araç-gereçlerinin BİT'lerdeki gelişmelere paralel olarak yenilenmesi önemlidir. Böylece toplumdaki tüm bireylerin, BİT'leri kullanarak istediği bilgiye, bilgi yığınları arasından seçmeleri, daha kolay ve daha hızlı ulaşabilmeleri ve ulaştıkları bilgiyi günlük yaşamlarında kullanabilmeleri sağlanmış olur. Bireylerin BİT becerileri ile donanık olarak yetiştirilmesinde ister şehir ister kırsal alanda görev yapsın öğretmenlerin rolü büyüktür. Özellikle de kırsal alanda görev yapan öğretmenlerin öğrenme-öğretme sürecinde BİT'leri kullanması, öğrencilerinin BİT ile karşılaşmalarını ve kullanma becerilerine sahip olmalarını sağlaması toplumdaki digital boşluğun giderilmesi açısından önemlidir. Bilgi ve iletişim alanındaki olanaklar, kaynaklar ve erişim dağılımındaki eşitsizliği ifade eden digital boşluğun giderilmesinde kırsal alanlarda görev yapan sınıf öğretmenlerin rolü büyüktür. Bu

bağlamda kırsal alanda görev yapan sınıf öğretmenlerin bilgi ve iletişim teknolojilerini sınıflarında kullanması ile ilgili deneyimlerinin, görüşlerinin ve yaşadıkları sıkıntılarının belirlenmesi, BİT'lerin öğretim-öğrenme sürecinde daha işlevsel olarak kullanılması ile ilgili olarak paydaşlara bilgi vermesi açısından önemlidir. Dolayısıyla bu çalışmanın amacı da kırsal alanlarda görev yapan sınıf öğretmenlerinin, BİT'leri bir öğretim aracı olarak kullanımı ile ilgili görüşlerini ve karşılaştıkları sorunlarının ortaya çıkarılmasıdır. Araştırmada, fenomenoloji yaklaşımından yararlanılmıştır. Fenomenoloji, katılımcıların deneyimlerini nasıl anlamlandırdıkları ve yorumladıklarını, yine katılımcıların algı ve açıklamalarına dayalı olarak, anlamaya çalışan nitel bir araştırma yaklaşımıdır. Araştırmanın katılımcıları amaçlı örnekleme türlerinden ölçüt örnekleme ile seçilmiştir. Araştırmaya kırsal alanda görev yapan 11 sınıf öğretmeni katılmıştır. Araştırmanın verileri, yarı yapılandırılmış görüşmeler ile toplanmıştır. Araştırmanın bulgularına göre kırsal alanda görev yapan sınıf öğretmenlerinin BİT'leri kullanımlarının, yeterli olmadığı sonucuna ulaşılmıştır.

Keywords: ICT, rural areas, the digital gap

LİSE ÖĞRENCİLERİNİN “AKILLI TAHTA” KAVRAMINA İLİŞKİN METAFORLARI

METAPHORS OF HIGH SCHOOL STUDENTS ON THE CONCEPT OF “SMART BOARD”

Ahmet Oğuz AKTÜRK
Necmettin Erbakan Üniversitesi, Ereğli Eğitim Fakültesi
Bilgisayar ve Öğretim Teknolojileri Eğitimi Bölümü
aoakturk@konya.edu.tr

Sinem MIHÇI
Necmettin Erbakan Üniversitesi, Ahmet Keleşoğlu Eğitim Fakültesi
Bilgisayar ve Öğretim Teknolojileri Eğitimi Bölümü
sinem-html@hotmail.com

İsmail ÇELİK
Necmettin Erbakan Üniversitesi, Ahmet Keleşoğlu Eğitim Fakültesi
Bilgisayar ve Öğretim Teknolojileri Eğitimi Bölümü, Meram, Konya
icelik@konya.edu.tr

ÖZET: Bu araştırmanın temel amacı, lise öğrencilerinin “Akıllı Tahta” kavramına ilişkin sahip oldukları algıların, metaforlar aracılığı ile ortaya çıkarılmasıdır. Araştırmada nitel araştırma desenlerinden birisi olan olgubilim deseni kullanılmıştır. Araştırmanın çalışma grubunu bir Anadolu Ticaret lisesinin Bilişim Teknolojileri bölümünün 9, 10, 11 ve 12. sınıflarında öğrenim gören toplam 162 öğrenci oluşturmaktadır. Araştırma verilerin toplanabilmesi için çalışma grubundaki her öğrenciye “Akıllı Tahta ... gibidir, çünkü ... ” cümlesi yöneltilmiş ve boşlukların doldurulması istenmiştir. Verilerin analizinde içerik analizi tekniğinden yararlanılarak öğrenciler tarafından oluşturulan metaforların ortak özelliklerine göre gruplandırılması amaçlanmıştır. Toplanan verilerin analizi sonucunda katılımcıların 41 geçerli metafor ürettiği ortaya çıkmıştır. Bu metaforlar özellikleri bakımından 6 kavramsal kategori altında toplanmıştır. Sonuç olarak, öğrencilerin “Akıllı Tahta” hakkında oldukça olumlu kavramlara sahip oldukları ortaya çıkmıştır. Bunun yanında bazı öğrencilerin ise “Akıllı Tahta”yı gereksiz bir araç olarak algıladıkları görülmüştür.

Anahtar sözcükler: FATİH Projesi, Akıllı tahta, Metafor, Akıllı tahta algısı.

ABSTRACT: The main purpose of this study is to reveal the perception that high school students' have on the concept “Smart Board”. In this research phenomenology which is one of a qualitative research, is used. The study constitutes totally 162 students in an Anatolian Trade High School of Information Technology classes. In order to collect research data, the question “ Smart Board is like, because” is asked to he studens in the groupand want them to fill in the gaps. We aimed to have groups according to common characteristics of metaphors by using the technique of content analysis to analyze the data. As a result of the analysis of the data collected, it has emerged that the participants have produced 41 current metaphors. These metaphors are grouped as six conceptual categories in terms of their features. As a result,we have emerged that studentst have quite positive concepts about smart boards, besides some students' thoughts as an unnecessary tool fort hem.

Key words: FATIH Project, Smart board, Metaphors, Perception of smart board

GİRİŞ

Bilim ve teknolojinin hızla geliştiği günümüzde eğitim sisteminin en önemli görevi, bilgi çağına ayak uydurabilen nitelikli bireyler yetiştirmektir. Bu amacı gerçekleştirmenin bir yolu da, teknolojinin eğitimle bütünleşmesidir (Ayvacı, Nas, Şenel, & Nas, 2007). Teknoloji, yapıcı öğretim uygulamalarını başarıyla sonuçlandırmak için kullanılan bir araçtır. Araç olarak kullanılan teknolojiler daha anlamlı düşünmeyi sağlar (Jonassen, 1994).

Çağımızın teknolojik gelişmeleri sayesinde, eğitim uygulamalarına yeni imkânlar sağlanarak, kullanılan ortam ve yöntemler zenginleştirilmektedir (Koşar & Çiğdem, 2003). Eğitim hizmetlerini daha geniş kitlelere daha kaliteli biçimde götürebilmek için çağdaş eğitim teknolojisinin tüm olanaklarından etkili bir biçimde yararlanmak gerekmektedir. Bu olanaklardan yararlanmak suretiyle öğrenme-öğretme ortamını iyileştirmek, eğitimin kalitesini yükseltmek ve eğitim hizmetlerinin kapsamını genişletmek mümkündür (Yüksel, 2003). Günümüzdeki öğrenme ortamları; geçmiştekinden farklı olarak teknolojinin eğitim ortamına entegre edilmesiyle zenginleştirilme, öğrenmeyi ve anlamayı hem kolaylaştırıcı hem de zevkli hale dönüştüren bir şekle bürünme yolundadır. Yeni teknolojik gelişmeler ışığında öğrenme ortamlarının tasarımında teknolojinin etkili bir şekilde kullanılması gerekmekte; bu nedenle teknoloji, gelecekteki eğitim ortamlarının vazgeçilmez bir parçası olarak görülmektedir (Baki, Kösa, & Berigel, 2007). Teknolojinin eğitimde kullanılması öğrenciyi öğrenme ortamında etkin kılarak öğrenme ve öğretmenin niteliğini artırırken öğrenci ve öğretmenlerin hedefe ulaşmak için harcadıkları zamanı ve eğitimin maliyetini düşürmektedir (Akkoyunlu, 1998).

Doğan (2000)'a göre genç ve yetişkin öğrenci sayısındaki artışla birlikte eğitim hizmeti bekleyen bireylerin ilgi ve isteklerindeki çeşitlilik, eğitim kurumlarını yeni teknolojileri kullanmaya daha çok yönelmektedir. Bu amaçla Milli Eğitim Bakanlığı başta olmak üzere tüm eğitim kurumları sürekli teknolojiye yatırım yapmaktadır. Gelinen noktada Milli Eğitim Bakanlığı ve Ulaştırma Bakanlığı'nın işbirliği ile yürütülen Fırsatları Artırma ve Teknolojiyi İyileştirme Hareketi (FATİH) Projesi olarak adlandırılan projenin adımlarından biri de bütün dersliklerin geliştirilmiş akıllı tahta seçenekleri ile donatılmasıdır (MEB, 2013). Bu çapta yapılan büyük bir yatırımın öğrenci ve öğretmen üzerinden değerlendirilmesi, bir çıktı olarak akademik alana kazandırılması planlama sürecini etkilemesi açısından önemlidir. Ayrıca öğrencilerin derse yönelik tutum ve motivasyonları üzerindeki etkilerin ortaya konması da ayrı bir önem taşımaktadır. Akıllı tahta kullanıma yönelik öğrencilerden alınacak dönüt ve önerilerin de alana katkı sağlayacağı düşünülmektedir.

Sünkür, Şanlı ve Arabacı (2011) yaptıkları bir çalışmada öğrencilerin akıllı tahta kullanmaktan, akıllı tahtayla öğrenmekten, akıllı tahta üzerinden işlenen derslerden daha çok keyif aldıkları, akıllı tahta kullanıldığında derse daha iyi odaklandıkları, öğrenebildikleri ve akıllı tahta ile öğrenmenin daha kısa zaman aldığını düşündükleri sonucuna ulaşılmışlardır. Bu nedenle uygulayıcılar olarak öğretmenlerin teknik, teknolojik ve pedagojik destek ve eğitim almasının sağlanması, öğrencilerin de akıllı tahta uygulamaları konusunda eğitilmelerinin sağlanması önerilmiştir (Sünkür, Şanlı, & Arabacı, 2011).

Yeni nesil akıllı tahtalarda tahta yüzeyi, elektronik gözlerle taranmakta ve elin tahtaya her dokunuşu hassas bir şekilde algılanmaktadır. Bu sayede âdete bir tablet gibi ya da dokunmatik bir bilgisayar gibi çalışmaktadır. Tahta ekranının interaktif olması, öğrenciye ve öğretmene ekranda yapılanlara müdahale etme şansını vermekte böylece ders esnasında değişikliklere olanak sağlamakta ve bu değişiklikleri kaydedebilme özelliği tanımaktadır. Ses klipleri, animasyonlar ve öğrenme nesnelere gibi çok çeşitli materyallerin kullanılmasına imkân tanınmasıyla da ders çok daha anlaşılır hale gelmektedir (Erduran & Tataroğlu, 2009). Akıllı tahtanın bir özelliği de sınıf etkileşiminin sağlamak için tasarlanmış önemli bir eğitimsel bilgi ve iletişim aracı olmasıdır (Gillen, Staarman, Littleton, Mercer, & Twiner, 2007). Farklı derslerde yapılan birçok çalışma, derslerde akıllı tahta kullanımının öğrencilerin akademik başarılarını arttırdığını göstermektedir (Kaya & Aydın, 2011; Ateş, 2010; Delaney, 2007; Tate, 2003; Beeland, 2002).

FATİH Projesi kapsamında okullara kurulan akıllı tahtalar ile ilgili öğrenci algılarının metaforlar aracılığıyla belirlenmeye çalışıldığı bu çalışmada metaforların kullanılmasındaki temel amaç; öğrencilerin akıllı tahta ile ilgili zihinsel imgelerini ortaya çıkarmak ve öğrencilerin akıllı tahtaya bakış açılarını daha iyi anlamaya çalışmaktır. Metafor, bireye iki olay, olgu, konu ya da kavram arasında karşılaştırma yapmayı ve bunlar arasındaki benzerlikleri mecazlı bir anlatımla sunmayı sağlar. Böylece iki şey ile ilgili benzerliklere dikkat çeker ya da birini diğerinin yerine geçirerek açıklama olanağı sunar (Coşkun, 2010). Arslan ve Bayrakçı (2006)'ya göre metafor kullanımı, yaratıcı düşünme ve problem çözme becerilerinin gelişmesi için beyinde yer alan sağ ve sol beyin fonksiyonlarının dengeli olarak kullanılması sağlamaktadır. Metafor, bir bireyin yüksek düzeyde soyut, karmaşık veya kuramsal bir olguyu anlamada ve açıklamada kullanabileceği güçlü bir zihinsel araçtır (Saban, Koçbeker, & Saban, 2006). Metaforlar, bireylerin kendi dünyalarını çözümlenmelerine ve oluşturmalarına yönelik güçlü bir zihinsel modelleme mekanizmasıdır ve genellikle gerçek ve yaşantının, kişide nasıl yorumlandığının anlaşılması için kullanılmaktadır (Arslan & Bayrakçı, 2006). Bu çalışmada, FATİH Projesi kapsamında okullarda kullanılmaya başlanan akıllı tahtanın lise öğrencileri için ne anlam ifade ettiği, metafor analizi yöntemi ile belirlenmeye çalışılmıştır.

YÖNTEM

Bu çalışmada nitel araştırma desenlerinden biri olan olgubilim (fenomenoloji/ phenomenology) araştırma deseni kullanılmıştır. Olgubilim deseni farkında olunan, ancak derinlemesine ve ayrıntılı bir anlayışa sahip olunmayan olgulara odaklanmaktadır (Yıldırım & Şimşek, 2006). Olgubilim çalışmalarında genellikle bir olguya ilişkin bireysel algıların ortaya çıkarılması ve yorumlanması amaçlanmaktadır. Bu çalışmada da lise öğrencilerinin akıllı tahta ile ilgili belirtmiş oldukları algıları incelenmiştir.

Katılımcılar

Bu araştırmaya bir Anadolu Ticaret Meslek lisesinin Bilişim Teknolojileri bölümünde öğrenim görmekte olan 162 öğrenci katılmıştır. Araştırmaya katılan öğrencilerin cinsiyet ve sınıflarına göre dağılımı Tablo 1’de gösterilmiştir.

Tablo 1. Katılımcıların Cinsiyet ve Sınıflarına Göre Yüzde ve Frekans Dağılımları

Değişken	Seçenek	f	%
Cinsiyet	Kız	74	45.7
	Erkek	88	54.3
Sınıf	9	57	35.2
	10	58	35.8
	11	22	13.6
	12	25	15.4
Toplam		162	100

Tablo 1’e göre, araştırmaya katılan öğrencilerin 74’ü kız, 88’i ise erkektir. Ayrıca öğrencilerin 57’si 9. Sınıf, 58’i 10. Sınıf, 22’si 11. Sınıf ve 25’i 12. Sınıf öğrencisidir.

Verilerin Toplanması

Araştırmaya katılan lise öğrencilerinin “Akıllı Tahta” kavramına yönelik algılarını belirlemek için, öğrencilerin her birinden “Akıllı Tahta ... gibidir çünkü ...” cümlesini tamamlamaları istenmiştir. Başlangıçta öğrencilere metaforla ilgili gerekli açıklamalar yapılmıştır. Öğrencilerden özellikle akıllı tahtayı bir şekilde tanımlamak zorunda oldukları birkaç defa vurgulanmış ve yaptıkları tanımların sebepleriyle birlikte açıklama yapmaları gerektiği belirtilmiştir. Bunun için öğrencilere, sayfanın en üstünde ne yapmaları gerektiği ile ilgili bir açıklamanın ve “Akıllı tahta ... gibidir; çünkü ...” ifadesinin yazılı olduğu boş bir kağıt verilmiştir. Açıklama kısmında öğrencilerden sadece tek bir metafor üzerinde yoğunlaşarak, düşüncelerini yazmaları istenmiştir. Saban (2009), metaforların bir araştırma aracı olarak kullanıldığı çalışmalarda “gibi” sözcüğünün genellikle “zihinsel imgenin konusu” ile “zihinsel imgenin kaynağı” arasındaki bağı daha açık bir şekilde çağrıştırmak için kullanıldığını, “çünkü” sözcüğünün ise öğrencilerin kendi metaforlarına “gerekçe” (veya “mantıksal dayanak”) sunmalarını sağlamaya yardımcı olsun diye yerleştirildiğini belirtmektedir. Metaforları oluşturmak için öğrencilere 20 dakika verilmiştir. Amaç, öğrencilerin metaforlarla ilgili ilk düşüncelerinden faydalanmak olduğu için bu verilen sürenin yeterli olduğu düşünülmüştür. Öğrencilerin “Akıllı Tahta” kavramıyla ilgili yazmış olduğu yazılar bu araştırmanın temel veri kaynağını oluşturmuştur. “Akıllı Tahta... gibidir” ifadesiyle öğrencinin akıllı tahtayı neye benzediğini belirleyerek kavramı nasıl algıladığı ve “çünkü...” kısmı ile de algısını nasıl ifade ettiği ortaya konulmuştur.

Verilerin Analizi

Verilerin çözümlenmesinde içerik analizi tekniği kullanılmıştır. Yıldırım ve Şimşek (2006), içerik analizinin temel amacının toplanan verileri açıklayabilecek kavramalara ve ilişkilere ulaşmak olduğunu, betimsel analizde özetlenen ve yorumlanan verilerin içerik analiziyle daha derin bir işleme tabi tutulduğunu ve betimsel yaklaşımla fark edilemeyen kavram ve temaların bu analiz sonucu elde edildiğini belirtmiştir. İçerik analizinin temelindeki işlem birbirine benzeyen verileri belirli kavramlar ve temalar çerçevesinde bir araya getirmek ve bunları okuyucunun anlayabileceği bir şekilde organize ederek yorumlamaktır (Yıldırım & Şimşek, 2006).

Analiz ve metaforların araştırmacılar tarafından anlaşılma süreci şu aşamaları içermektedir: İlk olarak öğrencilerin ürettiği metaforlar alfabetik sıraya göre geçici olarak sıralanmıştır. Sıralama esnasında öğrencilerin metaforu açıkça belirtip belirtmediklerine bakılmıştır. Ayrıca boş bırakılan ve herhangi bir metafor içermeyen kağıtlar elenmiştir. Bazı öğrencilerin metafor belirtmek yerine akıllı tahta ile ilgili düşüncelerini paylaştıkları,

bazılarının ise metafor belirtmeler bile geçerli bir mantıksal dayanak sunmadıkları görülmüştür. Bütün bunlara bağlı olarak 42 kağıt elenerek kalan 120 kağıt değerlendirmeye alınmıştır.

İkinci olarak öğrenciler tarafından üretilen geçerli metaforlar tekrar gözden geçirilerek alfabetik sıraya göre dizilmiş ve daha sonra her bir metaforu temsil edecek örnek metafor ifadeleri seçilmiştir. Bunun amacı metaforların kategorilere ayrılmasına yardımcı olmak ve verilerin yorumlanmasını sağlamaktır. Örnek metaforlar belirlendikten sonra geçerli metaforlar benzerliklerine göre gruplandırılmıştır. Kategoriler, akıllı tahta algısının özellikleri bakımından gruplandırılan metaforlara göre geliştirilmiş ve 120 öğrenci tarafından üretilen metaforlar 6 gruba ayrılmıştır.

Üçüncü olarak araştırmanın geçerliği ve güvenilirliği saptanmıştır. Araştırma sonuçlarının geçerliğini garanti etmek için geçerlik ve güvenilirlik iki önemli kriterdir. İyi bir araştırmada bilginin ayrıntılı raporu ve araştırmacıların verilen sonuçlara nasıl ulaştığı geçerlik için önemli bir kriterdir (Yıldırım & Şimsek, 2006). Bu araştırmanın geçerliğini saptamak için bilgiyi toplama ve analiz etme süreci ayrıntılı bir şekilde açıklanmıştır. Dahası bu araştırmadan elde edilen bilgiler öğrencilerin yazılı ifadeleriyle desteklenmiştir. Araştırmanın güvenilirliğini sağlamak için elde edilen bilgiler, bu çalışmanın araştırmacıları tarafından analiz edilmiştir. Sonra araştırmacılar analizlerini karşılaştırmak için toplanmışlardır. Aynı zamanda araştırmada oluşturulan kategorilerde yer alan metaforların ilgili kategoriyi temsil edip etmediğini görmek için farklı bir uzman tarafından da analiz edilmiştir. Bu bağlamda öğrenciler tarafından üretilen metaforlar ve araştırmacılar tarafından geliştirilen kategoriler liste olarak uzmana verilmiştir. Uzmanın metaforları ilgili kategoriye yazması istenmiş, daha sonra da uzmanın ve araştırmacıların gruplandırmaları karşılaştırılmıştır. Karşılaştırmadan elde edilen fikir birliği ve ayrılıklarının sayısına göre araştırmanın güvenilirliğine karar verilmiştir. Güvenirlik, Miles ve Huberman (1994)'ın formülüne göre hesaplanmıştır. Güvenirlik = Aynı karar sayısı/(Aynı ve farklı kararların toplamı) bu hesaplama sonucunda araştırmanın güvenilirliği %92 olarak bulunmuştur. Nitel çalışmalarda uzman ve araştırmacı değerlendirmeleri arasındaki uyumun %90 ve üzeri olduğu durumlarda arzu edilen düzeyde bir güvenilirlik sağlanmış olmaktadır (Akt: Saban, 2009). Bu araştırmanın güvenilirlik çalışması kapsamında görüşüne başvuru uzman 4 metaforu [cam(3), tiyatro(1), bilgisayar(5), Salıpazarı(1)] araştırmacılarınkinden farklı bir kategoriye yerleştirerek ilişkilendirmiştir. Bu durumda, güvenilirlik = $110 / (110+10) = 0.92$ olarak hesaplanmıştır. Bu araştırmanın güvenilirlik çalışmasında %0.92 oranında bir güvenilirlik sağlanmıştır.

Sonuç olarak toplam 41 metafor ve içeriklerine göre 6 kategorinin geliştirilmesinden sonra metaforlar ve tüm bilgi SPSS istatistik programına aktarılmıştır. Bu işlemten sonra 41 metafor ve 6 kategoriyi temsil eden katılımcıların sayısı (f) ve yüzdeleri (%) hesaplanmıştır.

BULGULAR

Bu araştırmaya katılan öğrenciler "Akıllı Tahta" kavramı hakkında 41 geçerli metafor üretmişlerdir. Toplam metafor frekansının büyük çoğunluğunu oluşturan "öğretmen" metaforunu üreten 30 öğrenci bulunmaktadır. Ayrıca metaforların 23'ü sadece bir öğrenci tarafından üretilmiştir. Geriye kalan 18 metaforu üreten öğrenci sayısı 2 ile 30 arasında değişmiştir. Öğrenciler tarafından üretilen metaforlar genel olarak 6 gruba ayrılmıştır. Bunlar;

1. Öğretici ve yol gösterici bir araç olarak Akıllı Tahta,
2. Öğrenmeye yardımcı bir araç olarak Akıllı Tahta,
3. Bilgi kaynağı olarak Akıllı Tahta,
4. Mutluluk kaynağı olarak Akıllı Tahta,
5. Eğlence kaynağı olarak Akıllı Tahta,
6. Gereksiz bir araç olarak Akıllı Tahta (Tablo 2).

Tablo 2. "Akıllı Tahta" kavramı ile ilgili öğrenciler tarafından oluşturulan metafor kategorileri

Kategoriler	Metafor (Frekans)	Metafor Sayısı	Toplam Metafor Sayısı	%
1 Öğretici ve yol gösterici bir araç olarak Akıllı Tahta	Öğretmen (30), Anahtar(1), Tekerlek(1), Robot(1)	4	33	27.5
2 Öğrenmeye yardımcı bir araç olarak Akıllı Tahta	Arkadaş(9), Yazı tahtası(4), Cam(3), Tablet(3), Annem(2), Kalem(1), El(1), Uçak(1), Projeksiyon(1), Tiyatro(1)	10	26	21.7

3	Bilgi kaynağı olarak Akıllı Tahta	Kitap(12), Bilgisayar(5), Bilim adamı(2), Kütüphane(2), Ansiklopedi(1), Altın kaynak(1), Babam(1), Akıl küpü(1), İnternet(1), Süpermarket(1), Bilgi kutusu(1)	11	28	23.3
4	Mutluluk kaynağı olarak Akıllı Tahta	Çikolata(4), Şeker(2), Meyve(1),	3	7	5.8
5	Eğlence kaynağı olarak Akıllı Tahta	Sinema(6), Oyun(3), Televizyon(2), Mp3(2), Öğle arası(1), Teneffüs(1), Tivibu(1)	7	16	13.3
6	Gereksiz bir araç olarak Akıllı Tahta	Erkekler(4), Gereksiz(2), Zaman kaybı(1), Arsız bela(1), Hurda(1), Salı pazarı(1),	6	10	8.4
Toplam			41	120	100

Kategori 1. Öğretici ve yol gösterici bir araç olarak Akıllı Tahta

Bu kategoride 4 metafor toplam 33 öğrenci tarafından üretilmiştir (Tablo 2). Bu kategorideki metaforlar öğretmen(30), anahtar(1), tekerlek(1) ve robot(1)'tur. Bu kategoride üretilen metaforlardan önemli bir çoğunluğunu 30 öğrenci tarafından üretilen "öğretmen" metaforu oluşturmaktadır. Bu metaforları üreten öğrenciler akıllı tahtayı öğretici ve yol gösterici bir araç olarak görmektedir. Onlara göre akıllı tahta dersleri öğreten bir öğretmen gibi onlara dersleri aktaran ve bilgiye ulaşmalarına rehberlik eden yol gösterici bir araçtır. Bu kategoriyle ilgili metaforların bazıları ve geliştirilme nedenleri öğrenciler tarafından şu şekilde belirtilmiştir:

"Akıllı tahta öğretmen gibidir; çünkü akıllı tahtada da konu anlatımı olur ve biz konuları öğretmenden öğrendiğimiz gibi akıllı tahtadan öğreniriz." (Öğrenci 67)

"Akıllı tahta öğretmen gibidir; çünkü akıllı tahtada farklı uygulamalar ve eklentiler bulunur, içindeki bu eklentiler ders anlamamızı kolaylaştırdığı gibi konuyu pekiştirmek ve çeşitli etkinlikler yapmamıza da yardımcı olur." (Öğrenci 114)

"Akıllı tahta öğretmen gibidir; çünkü akıllı tahta öğretmen gibi bize derslere ait çoğu bilgiyi verir." (Öğrenci 25)

"Akıllı tahta öğretmen gibidir; çünkü bütün bilgileri öğrenmemizde kolaylık sağlayan bir araçtır." (Öğrenci 66)

"Akıllı tahta öğretmen gibidir; çünkü bize bilgi verir, içerisindeki ders modüllerinden bilgi alırız." (Öğrenci 69)

"Akıllı tahta öğretmen gibidir; çünkü öğretmenden öğrendiğimiz her şeyi akıllı tahtadan da öğrenebiliriz." (Öğrenci 83)

"Akıllı tahta öğretmen gibidir; çünkü ne zaman bilgiye ulaşmak istersem bana yardımcı olur." (Öğrenci 88)

"Akıllı tahta öğretmen gibidir; çünkü bize bütün derslerimize nasıl çalışmamız gerektiğini öğretiyor." (Öğrenci 110)

"Akıllı tahta öğretmen gibidir; çünkü öğretmenimizin bizi aydınlattığı gibi bizi aydınlatır ve bize yardımcı olur." (Öğrenci 111)

"Akıllı tahta anahtar gibidir; çünkü anahtarın kapıyı açması gibi akıllı tahtada bilgiye giden kapıyı açar." (Öğrenci 52)

"Akıllı tahta tekerlek gibidir; çünkü arabalar tekerlek olmadan yürüyemez hareket edemez, okuldaki derslerde akıllı tahtasız ilerlemiyor." (Öğrenci 80)

"Akıllı tahta robot gibidir; çünkü hem öğretir hem kızmaz." (Öğrenci 132)

Kategori 2. Öğrenmeye yardımcı bir araç olarak Akıllı Tahta

Bu kategoride 10 metafor 26 öğrenci tarafından üretilmiştir (Tablo 2). Bu kategorideki metaforlar arkadaş(9), yazı tahtası(4), cam(3), tablet(3), annem(2), kalem(1), el(1), uçak(1), projeksiyon(1) ve tiyatro(1)'dur. Bu metaforları üreten öğrenciler Akıllı Tahta kavramını öğrenmeye yardımcı bir araç olarak görmektedirler. Bu kategoriye ait metaforların bazıları ve geliştirilme sebepleri öğrenciler tarafından şu şekilde belirtilmiştir:

"Akıllı tahta arkadaş gibidir; çünkü derslerimizi yapmamızda yardımcı olur. Nasıl arkadaşından bilgi öğrenirsem akıllı tahtadan da bilgi öğrenirim." (Öğrenci 39)

"Akıllı tahta arkadaş gibidir; çünkü onunla ilgilenmek derslerde iyi gelir. Bilmediğin şeyleri sana öğretebilir." (Öğrenci 117)

"Akıllı tahta yazı tahtası gibidir; çünkü dersi kolay işlememize yardımcı olur." (Öğrenci 81)

“Akıllı tahta cam gibidir; çünkü her şeyi gösterir ve bizlere öğretir.” (Öğrenci 24)
“Akıllı tahta tablet gibidir; çünkü hem dokunmatik hem bilgisayar gibi hem de tablete çok benziyor. Tablet bilgisayarımda çalıştığım tüm ders modüllerini akıllı tahtada da kullanabiliyorum.” (Öğrenci 146).
“Akıllı tahta annem gibidir; çünkü anne gibi her konuda bana yardımcı olur.” (Öğrenci 32)
“Akıllı tahta kalem gibidir; çünkü istediğim her şeyi çok kolay yazarım. (Öğrenci 30)”
“Akıllı tahta el gibidir; çünkü her şeyi elimizle dokunarak bulabildiğimiz gibi akıllı tahtaya da dokunarak her şeyi bulabiliriz.” (Öğrenci 12)
“Akıllı tahta uçak gibidir; çünkü ulaşmak istediğimiz yere uçakla çok hızlı ve kolay bir şekilde ulaştığımız gibi akıllı tahtayla da bilgilere hızlı ve kolay bir şekilde ulaşabiliriz.” (Öğrenci 53)
“Akıllı tahta projeksiyon gibidir; çünkü bize kitaplardaki bilgileri yansıtarak, görüntüleyerek öğrenmemize yardımcı olur.” (Öğrenci 36)
“Akıllı tahta tiyatro gibidir; çünkü var olan gerçeği bize görsel olarak sunar.” (Öğrenci 124)

Kategori 3. Bilgi kaynağı olarak Akıllı Tahta

Bu kategoride 11 metafor 28 öğrenci tarafından sunulmuştur (Tablo 2). Bu kategorideki metaforlar kitap(12), bilgisayar(5), bilim adamı(2), kütüphane(2), ansiklopedi(1), altın kaynak(1), babam(1), akıl küpü(1), internet(1), süpermarket(1) ve bilgi kutusu(1)'dur. Bu metaforları üreten öğrenciler akıllı tahtayı her zaman faydalanabilecekleri bir bilgi kaynağı olarak görmektedirler. Bu kategoriyle ilgili metaforların bazıları ve geliştirilme nedenleri öğrenciler tarafından şu şekilde belirtilmiştir:

“Akıllı tahta kitap gibidir; çünkü birçok bilgi içerir ve öğrencileri bilgilendirir.” (Öğrenci 31)
“Akıllı tahta kitap gibidir; çünkü istediğim her türlü bilgiye akıllı tahtadan kolayca ulaşabiliyorum.” (Öğrenci 87)
“Akıllı tahta kitap gibidir; çünkü bilgileri saklar ve ulaşmak istediğimizde bize sunar.” (Öğrenci 96)
“Akıllı tahta bilgisayar gibidir çünkü aradığımız her türlü bilgi bilgisayarda olduğu gibi aradığımız her şey akıllı tahtada da vardır.” (Öğrenci 78)”
“Akıllı tahta bilim adamı gibidir; çünkü bilim adamlarının çoğu bilgiye sahip olduğu gibi akıllı tahtada da birçok bilgi var.” (Öğrenci 51)
“Akıllı tahta kütüphane gibidir; çünkü kütüphanede nasıl binlerce kitap arasından istediğimiz bilgilere ulaşıyorsak akıllı tahta da bilgilere daha hızlı ve çabuk bir şekilde ulaşmamızı sağlıyor.” (Öğrenci 113)
“Akıllı tahta ansiklopedi gibidir; çünkü ne zaman bir şeyi araştırmak istersek ansiklopediye bakarız. Akıllı tahtada da bir ansiklopedi gibi ihtiyacımız olan her şeye bakarız.” (Öğrenci 140)
“Akıllı tahta altın kaynak gibidir; çünkü tüm yararlı bilgiler ondadır.” (Öğrenci 161)
“Akıllı tahta akıl küpü gibidir; çünkü bilgileriyle bizi bilgilendirir.” (Öğrenci 9)
“Akıllı tahta internet gibidir; çünkü onun sayesinde bilgileri daha sistemli ve kolay bir şekilde buluruz.” (Öğrenci 62)
“Akıllı tahta süpermarket gibidir; çünkü ihtiyacımız olan bütün ders notlarını akıllı tahtadan bulabiliriz.” (Öğrenci 86)
“Akıllı tahta bilgi kutusu gibidir; çünkü öğrenciler için ders açısından gerekli olan bütün bilgiler kolay ve rahat bir biçimde bu kutunun açılmasıyla elde edilebilir.” (Öğrenci 149)

Kategori 4. Mutluluk kaynağı olarak Akıllı Tahta

Bu kategoride 3 metafor 7 öğrenci tarafından üretilmiştir (Tablo 2). Bu kategorideki metaforlar çikolata(4), şeker(2) ve meyve(1)'dir. Öğrencilere göre derslerde akıllı tahta kullanmak dersi daha iyi anlamalarına ve bundan dolayı da mutluluk duymalarına sebep olmaktadır. Bu kategoriyle ilgili metaforların bazıları ve geliştirilme nedenleri öğrenciler tarafından şu şekilde belirtilmiştir:

“Akıllı tahta çikolata gibidir; çünkü çikolata yerken mutlu olduğum gibi onu kullanırken de mutlu olurum.” (Öğrenci 49)
“Akıllı tahta çikolata gibidir; çünkü çikolatanın mutluluk verdiği gibi akıllı tahta da mutluluk verir.” (Öğrenci 119)
“Akıllı tahta şeker gibidir; çünkü şeker yediğim zaman kendimi enerjik ve mutlu hissettiğim gibi akıllı tahta kullandığımda da kendimi derslerde enerjik ve mutlu hissederim.” (Öğrenci 2)

“Akıllı tahta meyve gibidir; çünkü meyve yerken hem zevk alırım hem de vitamininden faydalanırım. Akıllı tahtayla ders işlerken dersi daha iyi anlıyorum ve dersi daha iyi anladığım için de mutlu oluyorum.” (Öğrenci 124)

Kategori 5. Eğlence kaynağı olarak Akıllı Tahta

Bu kategoride 7 metafor 16 öğrenci tarafından sunulmuştur (Tablo 2). Bu kategoride üretilen metaforlar sinema(6), oyun(3), televizyon(2), mp3(2), öğle arası(1), teneffüs(1) ve tivibu(1)'dur. Bu kategorideki metaforları üreten öğrenciler akıllı tahtayı hoşça vakit geçirebilecekleri bir eğlence kaynağı olarak görmektedirler. Bu kategoriyle ilgili metaforların bazıları ve geliştirilme nedenleri öğrenciler tarafından şu şekilde belirtilmiştir:

“Akıllı tahta sinema gibidir; çünkü ekranı çok büyük olduğu için ders olmadığı zaman akıllı tahtada film izlemek çok zevkli oluyor.” (Öğrenci 154)

“Akıllı tahta sinema gibidir; çünkü bütün sınıf 3 saat boyunca hiç ses çıkarmadan zevkle film izleyebiliyoruz.” (Öğrenci 123)

“Akıllı tahta oyun gibidir; çünkü akıllı tahta sayesinde arkadaşlarımla karşılıklı birçok oyunu oynayıp eğleniyoruz.” (Öğrenci 57)

“Akıllı tahta televizyon gibidir; çünkü akıllı tahta ile film izleyebiliyoruz.” (Öğrenci 44)

“Akıllı tahta mp3 gibidir çünkü akıllı tahtada arkadaşlarımla hep müzik dinleyip eğleniyoruz.” (Öğrenci 95)

“Akıllı tahta öğle arası gibidir; çünkü öğle arasında akıllı tahtada film izleyip, müzik dinlediğimiz için eğleniyoruz.” (Öğrenci 136)

“Akıllı tahta teneffüs gibidir; çünkü teneffüslerde akıllı tahtada hep oyun oynuyoruz.” (Öğrenci 137)

“Akıllı tahta tivibu gibidir; çünkü akıllı tahtadan bütün filmleri izleyip eğleniyoruz.” (Öğrenci 160)

Kategori 6. Gereksiz bir araç olarak Akıllı Tahta

Bu kategoride 6 metafor 10 öğrenci tarafından sunulmuştur (Tablo 2). Bu kategorideki metaforlar erkekler(4), gereksiz(2), zaman kaybı(1), arsız bela(1), hurda(1), Salıpazarı(1)'dir. Bu metaforları üreten öğrenciler akıllı tahtanın derslerde kullanılmasının gereksiz olduğunu düşünmektedirler. Bu kategoriyle ilgili metaforların bazıları ve geliştirilme nedenleri öğrenciler tarafından şu şekilde belirtilmiştir:

“Akıllı tahta erkekler gibidir; çünkü erkekler sürekli dersi kaynatıyorlar. Derste akıllı tahta kullanınca da dersin büyük bir bölümü kaynıyor.” (Öğrenci 129)

“Akıllı tahta gereksiz gibidir; çünkü pek bir işe yaramadığı gibi ses ve görüntü kirliliği yaratıyor.” (Öğrenci 159)

“Akıllı tahta zaman kaybı gibidir; çünkü tahtaya verilen uğraşa daha fazla ders işleyebiliriz.” (Öğrenci 23)

“Akıllı tahta arsız bela gibidir; çünkü gördükçe insanın huzurunu bitirir mutsuzluk verir.” (Öğrenci 100)

“Akıllı tahta hurda gibidir; çünkü derste kullanmaya çalıştığımızda sürekli bozulur.” (Öğrenci 131)

“Akıllı tahta Salıpazarı gibidir; çünkü bütün gereksizler başına toplanır ve dokunmak için kavgaderler.” (Öğrenci 139)

TARTIŞMA VE SONUÇ

Bu çalışmanın amacı, FATİH Projesi kapsamında okullarda kullanılmaya başlanan akıllı tahtanın lise öğrencilerine ne anlam ifade ettiğini metafor analizi yoluyla belirlemektir. Akıllı tahta algısı göz önüne alınarak lise öğrencileri tarafından üretilen 41 farklı metafor 6 gruba ayrılmıştır. Bu kategorilere göre “Akıllı Tahta” öğretici ve yol gösterici bir araç, öğrenmeye yardımcı bir araç, bilgi kaynağı, mutluluk kaynağı, eğlence kaynağı ve gereksiz bir araç olarak algılanmıştır. Bu kategorilerdeki en önemli metaforlar ise sırasıyla, “Öğretmen(30)”, “Arkadaş(9)”, “Kitap(12)”, “Çikolata(4)”, “Sinema(6)” ve “Erkekler(4)” dir.

Metafor çalışmalarının birçoğunda bir kavramın bütün olarak açıklanabilmesi için tek bir metaforun yetmeyeceği ifade edilmektedir. Saban, Koçbeker ve Saban (2006: s.504)'nın Yob (2003)'dan aktardığına göre; "Temelde metafor, söz ettiği olgunun kendisi değildir, onun sadece bir sembolüdür. Eğer bu olgunun kendisi olsaydı, metafora gereksinim olmazdı. Bu nedenle metafor söz ettiği olgudan farklıdır ve bu olguya ilişkin çok güçlü bir perspektif sunsa da çoğu zaman ondan daha azdır. Bu durumu telafi etmek içinde birçok metaforun işe koşulması gerekir". Bu çalışmada da buna benzer olarak akıllı tahta öğrenciler tarafından bir çok farklı metafor kullanılarak "Öğretici ve yol gösterici bir araç", "Öğrenmeye yardımcı bir araç", "Bilgi kaynağı", "Mutluluk kaynağı", "Eğlence kaynağı" ve "Gereksiz bir araç" olarak görülmektedir.

Araştırmadan elde edilen bulgulara göre en fazla metafor frekansına sahip kategori "Öğretici ve yol gösterici bir araç olarak Akıllı Tahta" (f = 33) kategorisidir. Buna göre katılımcıların %27.5'ine göre akıllı tahtanın öğretici ve yol gösterici bir yönü vardır. Alanyazın incelendiğinde de akıllı tahtanın öğretme ve öğrenmeyi artırıcı özelliği vurgulanmaktadır (Kennewell & Beauchamp, 2007; Smith, Higgins, Wall, & Miller, 2005; Wall, Higgins, & Smith 2005; Tataroğlu & Erduran, 2010). Beauchamp ve Kennewell (2008)'e göre akıllı tahtalar, sınıf içi uygulamalarda öğrenci motivasyonunu arttırmakta ve akıllı tahtaların bilgi ve iletişim teknolojileri kullanımında önemli bir yeri vardır. Kaya ve Aydın (2010) ilköğretim öğrencilerinin Sosyal Bilgiler dersindeki Coğrafya konularının öğretiminde akıllı tahta uygulamalarına ilişkin görüşlerini inceledikleri bir çalışmada ilköğretim öğrencilerinin akıllı tahta uygulamaları ile Sosyal Bilgiler dersini daha iyi anladıklarını belirttiklerini ifade etmişlerdir. Araştırmanın çalışma grubundaki öğrencilere göre akıllı tahta öğretmenin işini kolaylaştıran dersi görsel hale getiren ve daha kolay öğrenmelerini katkı sağlayan bir araçtır.

Araştırma bulgularına göre "Öğretici ve yol gösterici bir araç olarak Akıllı Tahta" kategorisinden sonra en fazla metafor frekansına sahip kategorinin "Bilgi kaynağı olarak Akıllı Tahta" (f = 28) kategorisi olduğu görülmektedir. Ayrıca bu kategori 11 farklı metaforla katılımcılar tarafından en fazla metaforun üretildiği kategoridir. Buna göre katılımcıların %23.3'ü akıllı tahtayı her zaman faydalanabilecekleri bir bilgi kaynağı olarak görmektedirler. Levy (2002), akıllı tahtaların öğretime katkısını "öğrenme kaynakları ve bilginin sunumu", "kavram ve fikirlerin açıklanması" ve "etkileşim ve etkinliklerin kolaylaşması" olmak üzere üç ana başlıkta toplamıştır. Akıllı tahtalar etkileşim için güçlü bir araçtır ve çok sayıda kaynağın ulaşılabilir olmasını sağlamakla birlikte tartışmayı ve interaktif öğrenmeyi destekler (Becta ICT Research, 2003). Bunlara ek olarak, eğer ihtiyaç duyulursa veya konu ile ilgili olarak ekstra bir kaynak gerekirse, öğretim sürecinde akıllı tahta ile internete bağlanıp bu kaynaklardan da faydalanabilme imkânı elde edilebilmektedir (Starkings & Krause, 2008).

Araştırmadan elde edilen bir diğer dikkat çekici bulgu ise akıllı tahtanın "Gereksiz bir araç olarak" görülmesidir. Katılımcıların akıllı tahtayla ilgili olarak bu kategorideki metaforları incelendiğinde, akıllı tahtanın ders esnasında kullanıma hazırlanmasının "zaman kaybı" na neden olduğu ve kullanım esnasında yaşanan teknik sorunlar nedeniyle "hurda" olarak algılandığı görülmektedir. İlgili alanyazında da buna benzer bulgular bulunmaktadır. Wall, Higgins ve Smith (2005)'e göre akıllı tahta, diğer teknolojik araçlar gibi teknik problemler yaratması ve dersin ortasında açılıp kapanmasının beklenmesi bakımından öğrenciler için problem teşkil etmektedir. Hall ve Higgins (2005), 6. Sınıf ilköğretim öğrencileri ile yürüttüğü bir çalışmada öğrencilerin akıllı tahta ile ilgili olarak, bazı teknik sorunları, öğretmenin ve öğrencilerin bilgi ve iletişim teknolojileri kullanımı becerilerinin yetersizliğini ve öğrencilerin teknolojiye erişim imkânlarının kısıtlı olmasını olumsuzluk olarak gördüklerini ifade etmektedir.

Sonuç olarak bu çalışma sonucunda öğrencilerin akıllı tahta ile ilgili olarak ürettikleri metafor ve bu metaforlardan elde edilen kategoriler dikkate alındığında; öğrencilerin 94'ünün (%78.3) Akıllı tahtanın öğretimsel yararlarının farkında oldukları ve akıllı tahta ile ilgili olumlu düşüncelere sahip oldukları, 16'sının (%13.3) akıllı tahtanın öğretimsel boyutundan çok film izleme, müzik dinleme ve oyun oynama gibi diğer özellikleri ile ilgilendikleri, 10'unun (%8.4) ise akıllı tahtanın öğretimsel yararlarının farkında olmadıkları ve olumsuz düşüncelere sahip oldukları ortaya çıkmıştır. Çıkan bu sonuçlara göre sınıf ortamında bu teknolojinin amacına uygun ve etkin bir biçimde kullanılabilmesini sağlamak üzere öğrenci ve öğretmenlerin akıllı tahtaya ve dolayısıyla da teknolojiye yönelik tutumlarının geliştirilmesine ihtiyaç olduğu görülmektedir. Eğitim ortamını zenginleştirilmesi ve dersin etkinliğini artırması açısından çok büyük yararlar sağlayan akıllı tahta gibi teknolojilerin öğretim ortamlarına nasıl entegre edilebileceği konusunda daha fazla araştırmanın yapılması önerilmektedir.

KAYNAKLAR

Akkoyunlu, B. (1998). "Eğitimde teknolojik gelişmeler". (Editör: Bekir Özer). *Çağdaş Eğitimde Yeni Teknolojiler* (s. 1-19). Anadolu Üniversitesi Açık Öğretim Fakültesi Yayınları No: 564. Eskişehir: Anadolu Üniversitesi.

- Arslan, M. M., & Bayrakçı, M. (2006). Metaforik düşünme ve öğrenme yaklaşımının eğitim/öğretim açısından incelenmesi. *Milli Eğitim*, 171, 100-108.
- Ateş, M. (2010). Ortaöğretim coğrafya derslerinde akıllı tahta kullanımı. *Marmara Coğrafya Dergisi*, 22, 409-427.
- Ayvacı, H. Ş., Nas, S. E., Şenel, T. ve Nas, H. (2007). Öğretmen adaylarının öğretim teknolojilerini kullanmaya yönelik düşünceleri ve bu teknolojileri kullanmaya yönelik yeterlilikleri. *The Proceedings of 7th International Educational Technology Conference, 3-5 May 2007* (pp. 432-438), Near East University, North Cyprus.
- Baki, A., Kösa, T. ve Berigel, M. (2007). Bilgisayar destekli materyal kullanımının öğrencilerin matematik tutumlarına etkisi. *The Proceedings of 7th International Educational Technology Conference, 3-5 May 2007* (pp. 44-49), Near East University, North Cyprus.
- Beauchamp, G., & Kennewell, S. (2008). The influence of ICT on the interactivity of teaching. *Education and Information Technologies*, 13(4), 305-315.
- Becta ICT Research (2003). What the research says about interactive whiteboards. Retrieved April 18, 2014 from http://dera.ioe.ac.uk/5318/1/wtrs_whiteboards.pdf
- Beeland, W. D. (2002). Student engagement, visual learning and technology: Can interactive whiteboards help? Retrieved April 26, 2014 from http://chiron.valdosta.edu/are/artmascript/vol1no1/beeland_am.pdf
- Coşkun, M. (2010). Lise öğrencilerinin “İklim” kavramıyla ilgili metaforları (Zihinsel imgeleri). *Turkish Studies International Periodical for The Languages, Literature and History of Turkish or Turkic*, 5(3), 919-940.
- Delaney, M. (2007). *Lines, curves, and graphs*. Retrieved April 29, 2014 from http://downloads01.smarttech.com/media/sitecore/en/pdf/research_library/k-12/using_the_smart_board_interactive_whiteboard_to_create_a_hands-on_approach_to_learning_mathematics.pdf
- Doğan, H. (2000). Bilgi teknolojileri ve eğitimi. *Adım bilimsel düşüncenin ürünü*. Eğitim Özel Sayısı. KKTC Ateş Matbaası.
- Erduran, A., & Tataroğlu, B. (2009). Eğitimde akıllı tahta kullanımına ilişkin fen ve matematik öğretmen görüşlerinin karşılaştırılması. *Proceedings of 9th International Educational Technology Conference (IETC2009), 6-8 May 2007* (pp. 14-21), Hacettepe University, Ankara, Turkey.
- Gillen, J., Staarman, J. K., Littleton, K., Mercer, N., & Twiner, A. (2007). A “learning revolution”? Investigating pedagogic practices around interactive whiteboards in British Primary classrooms. *Learning, Media and Technology*, 32(3), 243-256.
- Hall I., & Higgins, S. (2005). Primary school students’ perceptions of interactive whiteboards. *Journal of Computer Assisted Learning*, 21, 102-117.
- Jonassen, D. H. (1994). *Technology as cognitive tools: Learners as designers*. Retrieved April 29, 2014 from <http://itforum.coe.uga.edu/paper1/paper1>.
- Kaya, H., & Aydın, F. (2011). Sosyal bilgiler dersindeki coğrafya konularının öğretiminde akıllı tahta uygulamalarına ilişkin öğrenci görüşleri. *Zeitschrift für die Welt der Türken/Journal of World of Turks*, 3(1), 179-189.
- Kennewell, S., & Beauchamp, G. (2007). The features of interactive whiteboards and their influence on learning. *Learning, Media and Technology*. 32(3), 227-241, DOI: 10.1080/17439880701511073
- Koşar, E., & Çiğdem, H. (2003). “Eğitim ortamı tasarımı, araç-gereç ve materyal özellikleri”. *Öğretim Teknolojileri ve Materyal Geliştirme*. Ankara: Öğreti Pegem A Yayıncılık.
- Levy, P. (2002). *Interactive whiteboards in learning and teaching in two Sheffield schools: A developmental study*. Retrieved April 16, 2014 from <http://www.shef.ac.uk/eirg/projects/wboards>
- MEB (Milli Eğitim Bakanlığı). (2013). *Eğitimde fırsatları artırma teknolojiyi iyileştirme hareketi projesi (FATİH). Proje hakkında*. <http://fatihprojesi.meb.gov.tr/tr/icerikincele.php?id=6>, Erişim Tarihi: 08.04.2014.
- Saban, A. (2009). Öğretmen adaylarının öğrenci kavramına ilişkin sahip oldukları zihinsel imgeler. *Türk Eğitim Bilimleri Dergisi*, 7(2), 281-326.
- Saban, A., Koçbeker, B. N., & Saban, A. (2006). Öğretmen adaylarının öğretmen kavramına ilişkin algılarının metafor analizi yoluyla incelenmesi. *Kuram ve Uygulamada Eğitim Bilimleri*, 6(2), 461-522.
- Sünkür, M. Şanlı, Ö., & Arabacı, İ. B. (2011). Akıllı tahta uygulamaları konusunda ilköğretim II. kademe öğrencilerinin görüşleri (Malatya ili örneği). *5th International Computer & Instructional Technologies Symposium. 22-24 September*, Fırat University, Elazığ, Turkey.
- Smith, H. J., Higgins, S., Wall, K., & Miller, J. (2005). Interactive whiteboards: boon or bandwagon? A critical review of the literature. *Journal of Computer Assisted Learning*, 21(2), 91-101, DOI: 10.1111/j.1365-2729.2005.00117.x
- Starkings, S., & Krause, L. (2007). Chalkboard to smartboard - maths going green? *MSOR Connections*, 7(4), 13-15.
- Tataroğlu, B., & Erduran, A. (2010). Matematik dersinde akıllı tahtaya yönelik tutum ölçeğinin geliştirilmesi. *Turkish Journal of Computer and Mathematics Education*, 1(3), 233-250.

- Tate, L. (2003). *Using the interactive whiteboard to increase student retention, attention, participation, interest and success in a required general education collage course*. Retrieved April 23, 2014 from http://downloads01.smarttech.com/media/sitecore/en/pdf/research_library/higher_education/using_the_interactive_whiteboard.pdf
- Wall, K., Higgins, S., & Smith, H. (2005). 'The visual helps me understand the complicated things': pupil views of teaching and learning with interactive whiteboards. *British Journal of Educational Technology*, 36(5), 851-867, DOI: 10.1111/j.1467-8535.2005.00508.x.v
- Yıldırım, A. & Şimşek, H. (2006). *Sosyal Bilimlerde Nitel Araştırma Yöntemleri* (6. Baskı). Ankara: Seçkin Yayıncılık.
- Yüksel, S. (2003). *Öğretim teknolojileri ve materyal geliştirme*. Ankara: Pegem A Yayıncılık.

CORRELATIONS AMONG ASSESSMENT TECHNIQUES USED IN AN INTRODUCTORY PROGRAMMING COURSE

Cagin KAZIMOGLU
Cyprus International University
ckazimoglu@ciu.edu.tr

Umut TEKGUC
Cyprus International University
utekguc@ciu.edu.tr

Kamil YURTKAN
Cyprus International University
kyurtkan@ciu.edu.tr

ABSTRACT: Learning computer programming is often perceived to be a difficult task by novice programming students and there have been several studies into the failure rate of students learning to program. This study explores the correlations between introductory programming students' ability to program and their theoretical knowledge in computer programming in order to analyze whether or not their performance in written exams are genuine and accurate. A rigorous statistical analysis was conducted with 400 introductory programming students who were randomly selected without considering whether or not they had a good programming background. The findings of the study used inferential statistics in order to define the correlations between students' practical and theoretical exam results. Additionally, the correlations between students' department and their exam results were investigated in order to define whether or not students' departments have an impact on their success in exams.

Keywords: introductory programming, computer programming, learning to program, assessment of programming courses

INTRODUCTION

Various studies investigated the reasons why students find computer programming difficult and it was found that the attitudes of students play a key role regarding how difficult they find learning to program (Gomes & Mendes, 2007; Hawi, 2010; Coull & Duncan, 2011). Most introductory programming students perceive computer programming as a technical activity rather than a series of cognitive skills (Bennedsen & Caspersen, 2007). Previous studies sought ways to improve introductory programming courses and investigated the skills of those students who were unsuccessful (Butcher & Muth, 1985; Ford & Venema, 2010). It was found that most students fail to understand the underlying reasons behind the theoretical exams in introductory programming courses where the main concern is not to assess the skill of programming but to measure the ability of abstraction, modelling and debugging (Rajaravivarma, 2005; Dalal *et al.*, 2009).

As a result of these investigations, new instructional design methods were suggested (Ismail *et al.*, 2010; Pears, 2010; Hawi 2012), and the impact of various assessment methods were measured including but not limited to computer aided assessment, multiple choice questions, theoretical/written exams, practical exams, and programming assignments. (Ala-Mutka, 2005; Barros *et al.*, 2003; Chamillard & Braun, 2000; Daly & Waldron, 2004; Lopez *et al.*, 2008; Kuechler & Simkin, 2003).

Despite the encouraging work done in this area, to this day it is still arguable whether or not students comprehend the motivation behind the concept of abstraction, modelling and debugging and as a result of this, they do not always see the point of theoretical exams in introductory programming courses. Consequently, there is the common assumption that students who are studying a Computer Science degree tend to do better in computer programming than students who are not studying a Computer Science degree.

This paper is dedicated to measure these assumptions and in order to do this, a rigorous evaluation was undertaken to determine whether or not there is a significant relationship a) between students' theoretical and practical exam results; b) among students' departments and their theoretical and practical exams. It was aimed to measure whether or not there is a significant correlation between students' results in their theoretical exams with

the results they obtained in their practical exams. Both of these aspects are analyzed separately and in combination, to ensure the accuracy of the results and the benefits that can be derived from this.

EXPERIMENTAL DESIGN

A rigorous study was undertaken to compare theoretical exam results of students with their practical exam results in order to measure whether or not these results are correlated. These results were gathered from the Faculty of Engineering students who were in their first year. Due to the engineering formation and school policy, all engineering students are obligated to take the introductory to programming course at the Cyprus International University (CIU). There are nine different departments under the Faculty of Engineering at CIU which are Computer Engineering, Information System Engineering, Electric and Electronic Engineering, Industrial Engineering, Energy Engineering, Civil Engineering, Environmental Engineering, Management Information Systems and finally Computer Programming. Regardless of their departments, students received computer algorithms for the first couple of weeks during their introductory programming course where they were thought to draw flowcharts and wrote pseudo codes in order to develop their ability to think computationally. Having covered fundamentals of computer algorithms, students were introduced the C programming language and asked to attend two sets of theoretical and practical exams along the course. The first theoretical exam results are matched with the first practical exam results and the second theoretical exam results with the second practical exam results. The first set of exams were related to the structured computer programming concepts in C covering the most basic computer programming constructs: variables, sequence, decision making and loops. Consequently, the second sets of exams were linked to the modular computer programming specifically focusing on pre-defined and user-defined functions as well as arrays.

A total of 400 comparable valid results from theoretical and practical exams were gathered and entered into IBM software package used for statistical analysis (SPSS). The results of the exams were gathered randomly without considering whether or not students had prior knowledge or background in programming. The identities of students were kept confidential and only the departments of the students were used in the statistical analysis as nominal data. The theoretical and practical exam results were used as raw data to investigate the validity of the following research questions and their hypotheses:

#	Research Question	Null Hypothesis (H_0)	Alternative Hypothesis (H_a)
1	Is there a significant relationship between student's theoretical and practical exam results?	There is no significant relationship between students' theoretical and practical exam results.	Students' theoretical exam results are significantly related with their practical exam results.
2	Is there a significant relationship between students' theoretical exam results and their departments?	There is no significant relationship between students' theoretical exam results and their department.	There is a significant relationship between students' theoretical exam results and their department.
3	Is there a significant relationship between students' practical exam results and their departments?	There is no significant relationship between students' practical exam results and their department.	There is a significant relationship between students' practical exam results and their department.

In order to examine the results accurately in the context of the above research questions, it was crucial to identify the correct method for an inferential statistical analysis. As the experimental structure is based on investigating the relationship of theoretical and practical exam results in a sample group, a statistical hypothesis was needed to evaluate the correlations on the subject. Therefore, a procedure for carrying out either a Pearson's product-moment correlation coefficient or a Spearman's rank-order correlation was performed (henceforth referred to as Pearson's r and Spearman's correlation). A Pearson's r was to be selected should the data captured fit a normal distribution and similarly, Spearman's correlation was to be available if the data captured did not fit a normal distribution.

When working with regional data (i.e. exam results) that comes from a normally distributed population, a Pearson's r is used to identify the strength and direction of correlations between the variables. Similar to this, a Spearman's correlation is selected when data comes from a non-normal distribution. Both methods can be used to measure how strong a correlation is between two variables. However, in Spearman's correlation it is simply not possible to calculate the percentage of variance as a coefficient of determination whereas this can be

calculated in Pearson's r. Therefore, having entered the raw data into SPSS, the procedure for checking the normal distribution was undertaken in order to decide which statistical method to use for the analysis of data.

STATISTICAL ANALYSIS

Three different methods were used in order to identify the distribution of data: *Histogram*, *Quantile – Quantile Plots* and a *Skewness and Kurtosis normality check*.

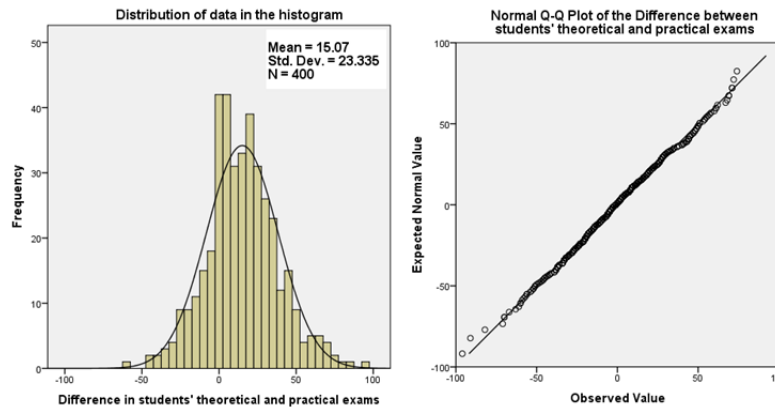

Figure 1. Normal Distribution Of Data In The Histogram And In The Normal Quantile – Quantile (Q-Q) Plot.

As shown in Figure 1, a histogram and a Quantile – Quantile (Q-Q) plot was used as the predominantly methods for observing how close the distribution of data is to a normal distribution. The histogram shows that there are skewness issues in the distribution of data as it is skewed to the right which causes an asymmetry in the distribution. Additionally, the histogram has kurtosis issues as the peak kurtosis point is over than what would be expected in a normal curve. Hence, there are clusters in the distribution of data which suggests that the data came from a non-normally distribution. On the other hand, the Q-Q plot shows that the differences in the exam results hug the linear line and no multiple clusters are visible which proves that the data obtained does not concentrate on specific points. In other words, the Q-Q plot provides strong reasons to believe that the data came from a normally distributed population.

Despite the strong evidence obtained from Q-Q plots, it was necessary to define the degree of Skewness and Kurtosis issues in terms of statistics, as the histogram did not support the results in Q-Q plots.

Table 1. Skewness And Kurtosis Normality Check On The Difference Between Practical And Theoretical Exams.

	N	Mean		Standard Deviation	Skewness		Kurtosis	
		Statistics	Std. Error		Statistics	Std. Error	Statistics	Std. Error
Difference between Pract. and Th. midterm	400	15.07	1.167	23.335	.186	.122	.563	.243
Difference between Pract. and Th. final	400	20.80	1.167	23.347	.118	.122	.298	.243
Valid N (listwise)	400							

As shown in Table 1, the Skewness and Kurtosis values are very close to 0. Moreover, the standard error calculation for Skewness ($0.122 \times 3 = 0.366 > 0.186$) and Kurtosis ($0.243 \times 3 = 0.729 > 0.563$) satisfy that the data came from a normally distributed population.

The above statistical procedures (i.e. histogram, Q-Q plots and Skewness and Kurtosis normality check) were discussed for the first research question only. Because the data set obtained for each research question has gone through the same normality tests, only the procedure for the first question is described here as the rest of the research questions were analyzed in the same way.

A Pearson's r was computed to assess the relationships among the exams (i.e. midterm and final) and their relationship to departments. As shown in Table 2, the correlations between the theoretical and practical exams are in positive direction, moderately strong and significant. There is a positive, modestly strong and significant association in between theoretical and practical midterm exam ($r=0.621$, $n=400$, $p=0.01$) and in between

theoretical and practical final exam ($r=0.651$, $n=400$, $p=0.01$). This means that the Pearson's coefficient provides strong evidence that the associations are moderately strong ($r^2=0.42$, 42%) between theoretical and practical exams.

Table 2. Pearson Product-Moment Correlation Coefficient showing relationships between Practical and Theoretical Exams.

** Correlation is significant at the 0.01 level (2-tailed).

		Theoretical Exam Midterm	Practical Exam Midterm
Theoretical Exam Midterm	Pearson Correlation	1	.621**
	Sig. (2-tailed)		.000
	N	400	400
Practical Exam Midterm	Pearson Correlation	.621**	1
	Sig. (2-tailed)	.000	
	N	400	400

		Theoretical Exam Final	Practical Exam Final
Theoretical Exam Final	Pearson Correlation	1	.651**
	Sig. (2-tailed)		.000
	N	400	400
Practical Exam Final	Pearson Correlation	.651**	1
	Sig. (2-tailed)	.000	
	N	400	400

Based on the analysis of data, two different conclusions can be drawn from the Pearson's r . Firstly, those students who did well in their midterm exams also did reasonably well (or even better) in their final exams as the difference between the coefficient number is very small (difference in $r = 0.03$, $p=0.01$). Secondly, there is no significant or strong difference between students' theoretical and practical exam results. There is a modestly strong correlation between the theoretical and practical exams in both cases which provides strong reasons to believe that those students who did well in their theoretical exams also did well in their practical exams. Hence, there is strong and significant evidence to support the alternative hypothesis for the first research question. In other words, the results provide strong reasons to believe that students' theoretical exam results are significantly related with their practical exam results.

One-way Multivariate analysis of variance (MANOVA) is used to determine whether there are any differences between the independent groups (i.e. students' department) on more than one continuous dependent variable (i.e. theoretical and practical exams, both midterm and final). At this point, it is crucial to note that the one-way MANOVA is an omnibus test and thus do not recognize which specific groups were significantly different from each other. In other words, it can only show that at least two groups were significantly different from each other. Because of this reason, a post-hoc test (i.e. Tukey's range test) was used but the results of this are not demonstrated here due to the lack of space. Additionally, MANOVA has a series of prior assumptions (e.g. no multivariate outliers, adequate sample size) and the validity of these were in order to ensure that the data obtained would not violate the results.

The MANOVA test included a single independent variable (i.e. students' department) and four dependent variables (students' theoretical midterm exams results, students' practical midterm exams results, student's theoretical final exam results and finally students' practical final exam results). The outcomes regarding the multivariate tests are given below:

Table 3. The Multivariate Tests^a table showing the second Effect, labelled "Department", and the Wilks' Lambda row

Effect		Value	F	Hypothesis df	Error df	Sig.
Intercept	Pillai's Trace	.166	38.901 ^b	2.000	390.000	.000
	Wilks' Lambda	.834	38.901 ^b	2.000	390.000	.000
	Hotelling's Trace	.199	38.901 ^b	2.000	390.000	.000
	Roy's Largest Root	.199	38.901 ^b	2.000	390.000	.000
	Pillai's Trace	.034	.842	16.000	782.000	.638
Department	Wilks' Lambda	.966	.840	16.000	780.000	.640
	Hotelling's Trace	.034	.838	16.000	778.000	.642
	Roy's Largest Root	.019	.919 ^c	8.000	391.000	.500

a. Design: Intercept + Department b. Exact statistic c. The statistic is an upper bound on F that yields a lower bound on the significance level.

As shown in Table 3, there was no statistically significant difference in student's performance with regard to their departments, $F(16, 780) = 0.84$, $p > .0005$; Wilk's $\Lambda = 0.966$. To determine whether the one-way MANOVA was statistically significant it was required to check the "Sig." value on the multivariate tests table, which in this case is 0.640. As the significant value is more than 0.005, it is possible to conclude that the alternative hypotheses for the second and third research questions can be rejected. In other words, there is no strong or significant evidence to support that students' performance in their theoretical and practical exams was related to which department they came from. Hence, the results of the one-way MANOVA provides strong reasons to believe that students' practical and theoretical exam results were not associated on which department they studied in.

CONCLUSION

As discussed earlier in the paper, majority of students tend to believe that practical exams have a higher impact of assessment than theoretical exams. Additionally, there is a common assumption that students who are studying a computer science degree perform better in computer programming than other engineering students. This study investigated how closely practical exams and theoretical exams were related to each other as well as whether or not the department of students has an impact on their performances. The statistical results gathered from this study provided strong reasons to believe that there is a significant relationship between student's theoretical and practical exam results. The results also show strong reasons to believe that there is no significant relationship between the students' department and their practical and/or theoretical exam results.

The information gathered during this study is only based on the overall results gathered from students' practical and theoretical exams. This study can further be expanded by analyzing the relationship of practical and theoretical exam results in terms of different programming constructs (such as loops, decision making, and functions). Therefore, it could be possible to detect which assessment methods work better on measuring which programming constructs.

REFERENCES

- Ala-Mutka, K. M. (2005). A survey of automated assessment approaches for programming assignments. *Computer Science Education*, 15(2), 83-102.
- Barros, J. P., Esteves, L., Dias, R., Pais, R., & Soeiro, E. (2003, June). Using lab exams to ensure programming practice in an introductory programming course. In *ACM SIGCSE Bulletin* (Vol. 35, No. 3, pp. 16-20). ACM.
- Bennedsen, J., & Caspersen, M. E. (2007). Failure rates in introductory programming. *ACM SIGCSE Bulletin*, 39(2), 32-36.
- Butcher, D. F., & Muth, W. A. (1985). Predicting performance in an introductory computer science course. *Communications of the ACM*, 28(3), 263-268.
- Chamillard, A. T., & Braun, K. A. (2000). Evaluating programming ability in an introductory computer science course. *ACM SIGCSE Bulletin*, 32(1), 212-216.
- Coull, N. J., & Duncan, I. M. (2011). Emergent requirements for supporting introductory programming. *Innovation in Teaching and Learning in Information and Computer Sciences*, 10(1), 78-85.
- Dalal, N., Dalal, P., Kak, S., & Antonenko, P. (2009). Rapid digital game creation for broadening participation in computing and fostering crucial thinking skills. *International Journal of Social and Humanistic Computing*, 1(2), 123-137.
- Daly, C., & Waldron, J. (2004, March). Assessing the assessment of programming ability. In *ACM SIGCSE Bulletin* (Vol. 36, No. 1, pp. 210-213). ACM.
- Ford, M., & Venema, S. (2010). Assessing the Success of an Introductory Programming Course. *Journal of Information Technology Education*, 9.
- Gomes, A., & Mendes, A. J. (2007). Learning to program-difficulties and solutions. In *International Conference on Engineering Education-ICEE* (Vol. 2007).
- Hawi, N. (2010). Causal attributions of success and failure made by undergraduate students in an introductory level computer programming course. *Computers & Education*, 54(4), 1127-1136.
- Hawi, N. S. (2012). A CAD (Classroom Assessment Design) of a Computer Programming Course. Online Submission.
- Ismail, M. N., Ngah, N. A., & Umar, I. N. (2010). INSTRUCTIONAL STRATEGY IN THE TEACHING OF COMPUTER PROGRAMMING: A NEED ASSESSMENT ANALYSES. *Turkish Online Journal of Educational Technology*, 9(2).
- Kuechler, W. L., & Simkin, M. G. (2003). How well do multiple choice tests evaluate student understanding in computer programming classes?. *Journal of Information Systems Education*, 14(4), 389-400.
- Lopez, M., Whalley, J., Robbins, P., & Lister, R. (2008, September). Relationships between reading, tracing and writing skills in introductory programming. In *Proceedings of the Fourth international Workshop on Computing Education Research* (pp. 101-112). ACM.
- Pears, A. N. (2010, October). Enhancing student engagement in an introductory programming course. In *40th Frontiers in Education Conference*, ser. *Proceedings of the Frontiers in Education Conference* (No. 40).
- Pears, A., Seidman, S., Malmi, L., Mannila, L., Adams, E., Bennedsen, J., ... & Paterson, J. (2007, December). A survey of literature on the teaching of introductory programming. In *ACM SIGCSE Bulletin* (Vol. 39, No. 4, pp. 204-223). ACM.
- Rajaravivarma, R. (2005). A games-based approach for teaching the introductory programming course. *ACM SIGCSE Bulletin*, 37(4), 98-102.

PRESERVICE PRIMARY MATHEMATICS TEACHERS' VIEWS ABOUT QUALITIES OF A GOOD TEACHER

Duygu ALTAYLI
Cumhuriyet University
duygu.altayli87@hotmail.com

Gülçin OFLAZ
Cumhuriyet University
erengulcin3@hotmail.com

ABSTRACT: The opinions of preservice primary mathematics teachers about the qualities that a good teacher need to have and how they can use these qualities in teaching programmes have been searched at this work. The research has been held with 6 students who attend the 4th grade at Primary Mathematics Teaching Department on the educational curriculum of 2012-2013. Case study method, which is a design of qualitative research design, has been used in this research. The data have been gathered by using the semi-structured interviewing technique and semi-structured interview forms. The interview with the preservice teachers has taken place before the Teaching Practice Lesson, and then their teaching samples have been observed. The correlation between what they have cited during the interview and the observation results have been examined. The in data analysis process and descriptive expressions have been used when analysing the data. It has been identified that a good teacher should have these qualities: communicative skills, material usage, improving himself/herself, time management, eradicating contential mistakes, attracting the students' interest in conclusion of the research. According to the findings from the observation, it has been seen that the preservice teachers have problems at time management.

Key words: Teacher, good teacher, preservice teacher

INTRODUCTION

It's been thought that the teachers, as an element of the education system, are the most important factor in order to develop a nation to be a nation of knowledge. Teachers are those who form the future of a nation. We must mention that the relation between today's teachers and tomorrow's people are very tight (Gündüz & Odabaşı,2002). So, it is very important that preservice teachers must be efficient in Professional way.

According to Gökçe (2000), a good teacher must be a good manager who manages the teaching process, a good observer and a qualified guide. So, teaching has become a profession that needs more quality and efficiency. Onural (2005) has asked the preservice teachers to express their ideas about an ideal teacher in his research. In conclusion, the most important qualities have been expressed as: efficiency in field , pedagogical formation and having fine communicative skills. Similar results can be seen at Aypay's (2011) research. He has identified that a good teacher should have communicative skills, have knowledge about his/her field and personel motivation.

In these research the qualities of a good teacher have been investigated in teachers' and preservice teachers' view. But it can be seen that very less researches have been held about how much of these thoughts on an ideal teacher have been used by the preservice teachers. That's why semi-structured observation has been held and analysed about their teaching facilities at Teaching Practice Lesson. after having a semi-structured interview with the preservice teacher. The correlation between what they said and what they did was investigated.

METHODS

Research Design

Case study method, which is a method of qualitative research method, has been used in this research. Case study provides the opportunity of examining one or more state deeply. The state is used for a person, a group or a program (Yıldırım & Şimşek, 2011).

Research Group

This research was held together with randomly chosen 6 students at last grade of a university's Primary Mathematics Teaching Department in Central Anatolia Region in the educational curriculum of 2012-2013.

Instruments

Semi-structured interviewing form and semi-structured observation form of qualitative data gathering technique has been used. At the first part of the research, the question of "What are the qualities of a good teacher?" have been asked to the randomly chosen students. Students' answers to the question is given at Table

Table 1: Students' Thoughts About The Qualities That A Good Teacher Should Have

CATEGORY	CODE	STUDENTS
A Good Teacher	Communication	S1, S2
	Using Material	S1,S3,S4
	Time Management	S2,S4,S5,S6
	Improving himself/herself	S2,S4,S5,S6
	Eradicating contential mistakes	S2,S3
	Attracting student's interest	S1, S2,S5

After this, semi-structured interviewing have been held with students to gain detailed knowledge from students. At the second part of the research, a researcher has observed the students' sample teaching practice at the Teaching Practice Lesson at their practicing school by using a semi-structured interviewing form. Video Recording Camera has been used while the observation.

2.4. Data Analysing

The data gained by interviewing and observation have been analysed using in data analysis process. Interview has been recorded by an audial device and then it has been transcribed and analysed by using the analysing process. The main questions have been determined as different categories. And codes have been created according to the answers. To provide validity, a colleague's confirmation has been asked. Students' descriptive citations has been given together with the categories and codes in order to develop the trustworthiness and reliability.

RESULTS AND FINDINGS

The semi-structured interview results about "the qualities that a good teacher must have", which is done with the Primary Mathematics Teachers, has been presented at this part of the research. Also, we have matched what the preservice teachers have said and their tutoring during their process.

Table 2. The Communicative Skills That Should A Good Teacher Should Have.

CATEGORY	CODE	STUDENTS
Communication	Empathy	S1, S6
	Usage of language	S2,S5,S6
	Being frank and easily understood	S2,S3,S6
	Respecting the student	S1,S2, S3,S4,S5

When examining Table 2, The preservice teachers have stressed that a good teacher should have fine communicative skills. They have stated that a good teacher shouldn't be rude and harsh to students, they should be emphatical and they should be use a well understanding and frank way of expressing knowledge.

S2: Teachers should always be tolerant and kind to students. They should regard the students as a person even though they are children and deal with their problems. Teachers should teach according to the students' learning level and should be encouraging to be active while learning. They should correct their the students's mistakes

by being motivating instead of being offensive.

When we observed the S2, we have seen that he has been close to students and been love to them. He thought the subject by increasing to students' levels. He avoided being offensive to students when they made a mistake.

Table 3. Preservice Teachers' Opinions About Using Materials At Mathematics

CATEGORY	CODE	STUDENTS
Material usage	Being concrete	S1,S2,S4,S5,S6
	Being attractive	S1,S2,S4,S5
	Being detailed	S1,S2
	Visualising	S2,S4

S1: Material is absolutely essential for some subjects. For example, 3D objects. Our preservice teacher uses material because it's impossible to understand it. Children have just started to think concretely. It's being complexive to teach 3D objects as they have newly started thinking concretely. So, i think its logical to show 3D objects on visual materials.

According to the observation result, it's been seen that S1 has used worksheets instead of 3D materials when teaching trigonometry.

Table 4. Preservice Students' Efficiency Thoughts About Time Management

CATEGORY	CODE	STUDENTS
Time management	Being unexperienced	S1, S4,S5
	Lack of self-esteem	S3
	Finding him/ herself efficient	S2,S6

At table 4, when we asked whether they can manage time while teaching, S1, S2 and S4 has mentioned that they believe in themselves but they're unexperienced and they can cope up with it in time. S5 have told us that he hasn't got confidence, and S3 and S6 has expressed that they could manage time, they haven't got any problems in managing time.

S5: It depends on situation and the subjects. Sometimes I predict that they can understand the subject easily but they don't understand some parts and time passes, on the other hand there times that students understand in shorter time that I predict. I'm unexperienced but I think I can manage time in future with more experience.

According to the observation results, S5 couldn't manage time and couldn't end the course in time even though he was planned and ready.

Table 5. Preservice Teachers' Thought About Keeping Up With Scientific Developments.

CATEGORY	CODE	STUDENTS
Developing	Mathematical issues	S1, S2,S3,S4,S5
	Articles	S2,S5
	Internet	S2,S3,S4,S5

What Preservice teachers think about keeping up with developing scientific progress after graduating from university takes place at Table 5. All of the preservice teachers stated that they will keep on following the innovations and will continuously be interested in issues, internet and scientific articles.

S3: I'm following the mathematic sites via internet, I'm following the "Mathematics World" issues, I am closely interested in technology. For instance, my dream is to teach by using the smart

board. I think these are important because children are following technology more than we do. We should keep up with technology and actual life by reading books too. Articles... Articles very useful to find out things.

S4: Recently, we have an issue called "Mathematics World", I enjoy reading it. It's not only totally about maths, there's analysis 2 and analysis 3 in it. I love remembering them. Being a mathematician feels great. There are also mathematic groups on internet and I follow them. I'm fond of being a mathematician.

Table 6. The Preservice Teachers's Perceptions About Removing Conceptional Complexities Of The Students.

CATEGORY	CODE	STUDENTS
Removing Conceptional Complexities	Alternative samples	S1, S2, S3,S4,S5,S6
	Telling the mistakes	S1
	Forming confusions on schemes	S2
	Revising	S4,S6

Table 6 shows the techniques that the preservice teachers will use to correct the conceptional mistakes that they've detected. All of the preservice teachers think that they'll ask an alternative question to the previous question in order to remove the confusion. S1 stated that he will tell the mistake and show the correct one, S2 told that he will form confusions on the schemes so that students can realize their own mistake, S4 and S6 answered that they will revise and re-teach the subject.

S4: Alternative samples. I'll give homework with various questions in it if there one or two students. But if its whole the class I'll re-teach the subject until the confusion takes no place.

It has been observed during teaching that S4 has given a sample example to correct a student's confusion. He then gave another example to reinforce.

Table 7. The Responses Of Preservice Teachers To Students Who Don't Listen Them

CATEGORY	CODE	STUDENTS
Attracting Students' Attention	Using gestures	S1, S4
	Showing/Telling sadness	S1,S5
	Oral warning	S2,S4,S6
	Wandering in the class	S3
	Ignoring	S4, S5

Preservice teachers' penalties towards the students who don't listen the teacher has mentioned at Table 7. The preservice teacher are using the techniques of non-verbal warnings (such as gestures or staring), verbal warning, knocking the board, ignoring, showing that he/she is getting upset.

S6: I generally stay close to the board when teaching. If they say something walk around the class so they don't whisper. If they talk when I'm writing something on the board, I go check whether they have written or not. They stop talking when I get close.

It has been observed that S6 went to talking students' seat and made stop talking. But when he went back to the board, they started talking again.

CONCLUSION

Preservice Teachers have stated that a good teacher should have the qualities of communicating, material using, mistake correcting and attending attracting. Preservice Teachers expressed that communicating is important for a good teacher. They stated that students should never be shouted at, teachers should utter words to motivate students, and they stated that using an

understanding way of teaching provides effective learning. This state shows similarity with Onural (2005) and Aypay's (2011) researches.

Preservice Teachers mentioned that they will ignore unwanted attitudes of the students, they will use repression, use body language and oral warnings in order to make them listen. They added that they will not be harsh on students, they don't want to make them upset. It can be said that they were kind and tolerant to students and they avoided being harsh on them. This shows that new generation teachers don't like violence and they want to solve problems by talking to students.

Preservice Teachers told that they aim to guide them to realise their own mistakes. At the observation findings, it has been seen that Preservice Teachers used alternative examples or they revised the confused subjects to remove confusion. This shows that structural approach is more popular among Preservice Teachers.

Preservice Teachers stated that using material is precisely essential. They have stressed that visualising and concretizing will be better and easier by using materials since mathematics is more difficult when comparing with other lessons and since mathematics is a concrete lesson. It is also thought that material using is effective in attracting students and making them enjoy maths. But when observing Preservice Teachers' teaching at the Practice Lesson, it has been seen that none of them used 3D materials, and they used worksheets instead.

Preservice Teachers stated that they will follow the developments in science and they will improve themselves after they graduate. This shows the positive sides of the newly used Training Mathematics Teacher System in Turkey (Umay,2001).

REFERENCES

- Aypay, A. (2011). İlk ve ortaokul öğretmenlerinin davranış alışkanlıkları ve "İyi öğretmen" özelliklerine ilişkin algıları. *İlköğretim Online*, 10(2), 620-645.
- Gökçe, E. (2000). Yirmibirinci yüzyılın öğretmeni. *Çağdaş Eğitim*. 270, Kasım.
- Gündüz, Ş. ve Odabaşı, F. (2002). Bilgi Çağında Öğretmen Adaylarının Eğitiminde Öğretim Teknolojileri ve Materyal Geliştirme Dersinin Önemi. *The Turkish Online Journal Of Educational Technology* , 3 (1), 43-48.
- Onural, H. (2005). Öğretmen adaylarının ideal öğretmen niteliklerine ilişkin görüşleri. XVI. Ulusal Eğitim Bilimleri Kongresi Pamukkale Üniversitesi Eğitim Fakültesi. 28-30 Eylül.
- Umay, A. (2001). İlköğretim matematik öğretmenliği programının matematiğe karşı özyeterlik algısına etkisi. *Journal of Qafqaz University*. 8.
- Yıldırım, A. & Şimşek, H. (2005). *Sosyal bilimlerde nitel araştırma yöntemleri* (5.baskı). Ankara: Seçkin Yayıncılık.

FARKLI ÖĞRENME STİLLERİNİN FEN BİLGİSİ ÖĞRETMEN ADAYLARINDA PROJE PERFORMANSI VE AKADEMİK BAŞARIYA ETKİSİNİN İNCELENMESİ

AN INVESTIGATION OF THE EFFECT OF DIFFERENCE LEARNING STYLES TO ACADEMIC ACHIEVEMENT AND PROJECT PERFORMANCE ON SCIENCE TEACHER CANDIDATES

Nurhan ATALAY

Eskişehir Osmangazi Üniversitesi, Eğitim Fakültesi, İlköğretim Bölümü
nurratalay@gmail.com

Yusuf AY

Eskişehir Osmangazi Üniversitesi, Eğitim Fakültesi, İlköğretim Bölümü
yusufmoon@hotmail.com

ÖZET: Araştırmanın amacı, farklı öğrenme stillerine sahip fen bilgisi öğretmen adaylarının, projeye performans puanları ve akademik başarıları arasındaki farklılığın belirlenmesidir. Araştırma ilişkisel tarama modelinde betimsel bir çalışmadır. Araştırmanın çalışma grubunu Genel Fizik I Laboratuvar dersini alan 80 fen bilgisi öğretmen adayı oluşturmaktadır. Verilerin toplanmasında, Grasha-Riechmann öğrenme stili envanteri, oluşturulan projeleri değerlendirmek için Bahar (2009)'un geliştirdiği proje değerlendirme derecelendirme ölçeği (rubrik) kullanılmıştır. Akademik başarı olarak öğretmen adayların genel akademik başarı ortalamaları alınmıştır. Verilerin analizinde %, f ve tek yönlü varyans analizi (ANOVA) kullanılmıştır. Araştırma sonuçlarına göre; farklı öğrenme stillerine sahip fen bilgisi öğretmen adaylarının proje performans puanları arasında anlamlı bir fark görülürken, akademik başarıları arasında anlamlı bir farklılık söz konusu değildir

Anahtar sözcükler: Fen bilgisi öğretmen adayları, Grasha ve Riechman öğrenme stili, akademik başarı, proje performansı

ABSTRACT: The aim of the research is to investigate the effect of difference learning styles to academic achievement and project performance on science teacher candidates. This cross-sectional study was carried out with 80 Science teacher candidates attending general physics I course. Data of the study was collected through "Grasha-Riechmann Learning Styles inventory" and "Project Evaluation Rating Scale" for projects. Academic achievement has been average overall academic performance of teacher candidates. Descriptive statistics, %, f and one-way ANOVA were used for data analysis. According to research results; while teacher candidates' learning styles is made significant changes on performance points, there is no significant changes on academic achievement.

Key words: Science teacher candidates, Grasha and Riechman learning styles, academic achievement, project performance

GİRİŞ

Bilgi çağının ve bilgi toplumlarının öne çıktığı günümüzde artık eğitimin temel amacı, bilgiyi öğrenenlere aktarmak değil, onlara bilgiye ulaşma yollarını öğretmektir. Öğrenen bireylere bilgiye ulaşma yollarını öğretmek ancak onlara üst düzey düşünme becerilerini, 21. yy. öğrenen özelliklerini kazandırabilmekle sağlanabilir. . Böylece, bilgi çağında yaşayan bireylerin, Özer'in (2001) de belirttiği gibi, bilgiye erişme yollarını bilmeleri, ulaştıkları bilgiyi kullanabilmeleri ve yeni bilgiler üretebilmeleri önem kazanmaktadır. Bireylerin bu niteliklere sahip olmalarının en etkili yolu, onların nasıl öğreneceklerini öğrenmeleri, daha kalıplaşmış bir deyişle "öğrenmeyi öğrenme" leri ile olanaklıdır. Bu özelliklerin kazandırıldığı derslerin başında fen bilimleri dersi gelmektedir. Fen bilimleri dersinde öğrenenler, çevrelerinde olan biten olayları inceleme, evreni bilimsel anlamda ele alma fırsatı yakalarlar. Bireylerin bilimsel süreç becerilerinin önemli bir parçası olan gözlemi doğal ortamda edindikten sonra fen derslerinde uygulamaya dönük olarak irdeleme fırsatı bulurlar. . Fen bilimleri dersinde bilgiye ulaşma ve bilgiyi keşfetme yollarından birisi de proje çalışmaları, proje tabanlı öğrenme yöntemidir.

Proje tabanlı öğrenme, bir konunun derinlemesine araştırılmasını amaçlar. Bu araştırmalarda öğrenen aktiftir, öğrenme etkinlikleri bazen bir grupla bazen de bireysel olarak yürütülür. Proje tabanlı öğrenme projeler yoluyla öğrenmeyi organize eden bir model olarak da açıklanabilir (Thomas, 2000). Korkmaz (2002)'a göre proje tabanlı öğrenmenin temeli büyük ölçüde John Dewey'in yeniden yapılanma, Kilpatrick'ın Proje metodu, Bruner'in Buluş Yoluyla Öğrenme Yaklaşımı ve Thelen'in Grup Araştırması Modeline dayanmaktadır. John Dewey'den başka ilerlemeci eğitimin bir başka temsilcisi olan William Kilpatrick proje tabanlı öğrenmenin ilk uygulayıcısı olarak bilinir (Balkı, 2003). Proje tabanlı öğrenme yöntemi aynı zamanda yapılandırmacılık yaklaşımının uygulamasında ön görülen yöntemlerden birisidir.

Yapılandırmacı yaklaşımda öğretmene göre öğrenci, aktiftir. Yapılandırmacılık bireylerin çevreleri ile etkileşimlerinin bir sonucu olarak meydana gelen bilgi inşasına dayanır ve her bir oluşum diğerlerinden farklı özellikler taşır. Proje Tabanlı Öğrenme gibi Yapılandırmacı öğrenme tasarımları geleneksel öğretim yöntemlerine alternatif olarak düşünülmektedir (Aşan ve Haliloğlu, 2005). Bu bağlamda bilgiyi nasıl öğrendiğimiz hakkında iki önemli farklılık vardır. Bunlardan birincisi, bilgiyi nasıl algıladığımızdır; ikincisi, algıladığımız bilgiyi nasıl işlediğimizdir. Her birimiz gerçekleri farklı olarak algılarız, farklı yöntemlerle zihnimize yerleştiririz. Bazılarımız hissederek, bazılarımız izleyerek, bazılarımız düşünerek, bazılarımız yaparak gerçeklere ulaşırız (Morris ve McCarthy, 1990; McCarthy, 2000). Bu bağlamda uygulamalı ya da performans dayalı olan proje çalışmaları, fen öğreniminde ve öğreniminde önemli bir yere sahiptir. Birçok araştırmada uygulamalı ya da performansa dayalı çalışmalardan öğrencilerin zevk aldığı, bu tür etkinliklere karşı olumlu bir tutum geliştirdikleri söylenmektedir (Johnstone ve Al-Shuaili, 2001; Kapenda, Kandjeo-Marenga ve Kasanda, 2002).

Her öğretim yaklaşımında olduğu gibi projelerdeki öğrenci performanslarının da bireysel farklılıklar gibi psikolojik faktörlerden etkilendiği belirlenmiştir. Proje hazırlarken motivasyon stilleri ve bilişsel stiller anlamında projelerin kimi öğrenciler için önemli ve motive edici iken diğer öğrenciler olumsuz etkisinin olduğu yada etkisinin olmadığı görülmüştür (Al-Naeme, 1991; Johnstone ve Al-Naeme, 1995). Bireyin kendi öğrenme özelliklerini tanıması, öğrenmede yararlanılan stratejileri bilmesi, seçmesi ve kullanabilmesi olarak tanımlanan öğrenmeyi öğrenme kavramı, bireyin kendi öğrenme özelliklerini tanımasını öncelikli kılmaktadır ki böylelikle karşımıza “öğrenme stili” kavramı çıkmaktadır (Özer, 2001). Öğrenme stillerini işe koşarak gerçekleştirecek bir öğretim, bir öğrencinin nasıl öğrendiği ve nasıl öğrenmekten hoşlandığı gibi bilgilerin kullanılmasını, böylece öğrencilerin kendi öğrenme özellikleri doğrultusunda daha kolay ve kalıcı öğrenmelerin gerçekleşmesini sağlayacaktır.

Son otuz yıl içerisinde fen eğitiminde olduğu kadar diğer birçok alanda bireysel farklılıklara odaklanan çok sayıda araştırma yapılmıştır. Her bireyin dünyayı anlamak için kullandığı öznel bir bilgi kapasitesine, düşüncelere ve deneyimlere sahip olduğu ve tüm bu özelliklerin öğrenme sürecinde etkili olabileceği düşünülürse öğrenmede bireysel farklılıkların varlığını kabul etmek kaçınılmazdır. Alan yazında bazen birbirinin de yerine kullanılan fakat esasında anlam itibari ile farklılıklar arz eden bireysel farklılıklara ilişkin bilişsel stil, bilişsel strateji, öğrenme stili ve öğrenme stratejisi gibi bazı kavramlar kullanılmaktadır (Bahar, 2009).

Öğrenme stili ile ilgili alanyazında farklı tanımlara rastlanabilir. Keefe (1991) öğrenme stilini hem bir öğrenci karakteristiği hem de öğretme stratejisi olarak tanımlar. Öğrenme stili, öğrenci karakteristiği olarak bir öğrencinin nasıl öğrendiğini ve nasıl öğrenmekten hoşlandı-ğını belirtir. Öğretim stratejisi olarak da biliş, şartlar ve öğrenme içeriği hakkında bilgi verir. Dunn ve Dunn (1993) öğrenme stilini her bireyde farklılık gösteren, bireyin yeni ve zor bir bilgi üzerine odaklanması ile başlayan bilgiyi alma ve belleğe yerleştirme süreciyle devam eden bir yol olarak ifade etmiştir. Kolb (1984) ise öğrenme stilini, bilgiyi algılama ve işlemede kişisel olarak tercih edilen yöntem olarak ifade etmiştir. Grasha ve Riechmann tarafından tanımlanan öğrenme stilleri, bireyin öğrenme tercihlerine yönelmesi bakımından, görünüşte Dunn tarafından keşfedilen yapıya oldukça benzemektedir. Grasha ve Riechmann, akademik çerçevede öğrenmeyi destekleyen, tercih edilen davranış ve tutum kalıpları üzerine sosyal ve etkili bir bakış açısı sunmuşlardır (Riding ve Rayner, 1998).

Grasha ve Riechmann tarafından açıklanan kişilerin öğrenme tercihleri üzerine odaklanmış öğrenme stili modeli, görünüşte Dunn tarafından tasarlanmış yapıya benzerlik göstermektedir. Grasha ve Riechmann, akademik bağlamda tercih edilen davranış ve tutum örnekleri üzerine sosyal ve etkileyici bir bakış açısı sunmuşlardır (Riding ve Rayner, 1998). Grasha ve Riechmann öğrenme stilleri modeli, üst sınıflardaki lise öğrencileri ve üniversite düzeyindeki öğrenciler için daha uygun bulunmuş ve bu düzeydeki öğrenciler için kullanılmıştır. Öğrenme stillerinin değişmez nitelikte olduklarını kabul etmekle birlikte Grasha ve Riechmann, her bir öğrenci için stillerin sınıftan sınıfa değişebileceğini vurgulamaktadır. Çünkü, model sosyal etkileşime dayanmaktadır ve her bir ders için öğrencilerin göstereceği tutum ve davranışlar farklılık gösterebilmektedir. Bu

nedenle, öğrenme stillerini ölçmede geliştirdikleri skala, belirli bir dersi ölçmek için ve genel bir değerlendirme yapmak için iki farklı biçimde tasarlanmıştır.

Grasha ve Riechmann tarafından geliştirilmiş bu model, diğer öğrenme stilleri modellerinden farklılık göstermektedir. Öğrencilerin kişisel ve bilişsel özelliklerinin genel değerlendirmesinden çok, onların sınıf etkinliklerine karşı tutumlarının temel alındığı bir modeldir. Bu yönüyle Grasha, modelin çok daha gerçekçi ve geçerli olduğunu savunmaktadır. Çünkü, modelin öğrenme stillerini sınıflandırması, öğretme yöntem ve tekniklerinin belirlenmesinde tüm öğretim personeline ve kurumlarına yardımcı olması amacıyla tasarlanmıştır (Montgomery ve Groat, 2004).

Grasha ve Riechmann, öğrencilerin öğrenme ortamlarında tercih ettikleri stil kalıplarını, üç boyutta tanımlamışlardır (Jonassen ve Grobowski, 1999):

- Öğrencinin öğrenmeye karşı tavrı
- Öğretmenlerin/yaşıtların görüşü
- Ders prosedürlerine karşı verilen tepkiler

Bu üç boyutun karşılığında ise, modeli tanımlayan üç tane iki kutuplu boyut keşfetmişlerdir. Bunlar: *Katılımcı / kaçınan, İşbirlikçi / yarışmacı, Bağımsız / Bağımlı*'dir.

Tablo 1. Öğrencilerin Sınıf Ortamındaki Öğrenme Tercihlerine Karşılık Olabilecek Her Bir Stilin Karakteristik Özelliklerini

Katılımcı	Kaçınan
*ders içeriğini öğrenmeye heveslidir	*ders içeriğini öğrenme heveslisi değildir
*derse devam etmekten hoşlanır	*derse devam etmekten hoşlanmaz
*sınıf içi öğrenmede sorumluluk alır	*sorumluluk almaz
*söylenildiğinde katılımında bulunur	*katılımda bulunmaz
*istenileni yapar	*kendi istediğini yapar
İşbirlikçi	Yarışmacı
*paylaşıcıdır	*yarışmacıdır
*işbirlikçidir	*başkalarından daha iyi yapma motivasyonuna sahiptir
*başkalarıyla çalışmaktan hoşlanır	*yarışmaktan hoşlanır
*sınıf öğrenme ve başkalarıyla etkileşimde bulunma yeridir	*sınıf kazanmak zorunda olduğu bir kazan ya da kaybet yeridir
Bağımsız	Bağımlı
*kendisi düşünür	*öğretmen bir bilgi ve yapı kaynağıdır
*kendi başına çalışır	*ne yapmasını söyleyecek otoriteye gereksinme duyar
*gerekeni öğrenecektir	*yalnızca isteneni öğrenecektir
*başkalarını dinleyecektir	*düşük derecede entelektüel merakı vardır
*kendine güvenir	*kendine güveni azdır

Araştırmada, Fen Bilgisi öğretmen adayları tarafından oluşturulan proje çalışmalarının başarısının, gruplardaki öğrencilerin öğrenme stillerine göre farklılaşıp farklılaşmadığı incelenmiştir. Öğretmen adaylarının yapılandırılan projelerde gösterdikleri performansı etkileyebilecek Grasha'nın öne sürdüğü öğrenme stilleri (rekabetçi, iş birlikli, pasif, katılımcı, bağımlı ve bağımsız) ve genel akademik başarıları arasındaki ilişki araştırılmıştır Alan yazında öğretmen adaylarının öğrenme stillerinin, yapılandırılan projelere etkisini ortaya koyan araştırmalara rastlanmamıştır. Bu bağlamda araştırma, alan yazına katkı sağlaması açısından önemlidir. Araştırmada aşağıdaki sorulara yanıt aranmaktadır:

1. Farklı öğrenme stillerine sahip olan öğrencilerin proje performans puanları arasında anlamlı bir farklılık var mıdır?
2. Farklı öğrenme stillerine sahip öğrencilerin akademik başarıları arasında anlamlı bir farklılık var mıdır?

YÖNTEM

Araştırma Modeli

Araştırma ilişkisel tarama modelinde betimsel bir çalışmadır. İlişkisel tarama modelleri, iki ya da çok sayıda değişken arasında birlikte değişim varlığını ve/veya derecesini belirlemeyi amaçlayan araştırma modelleridir (Karasar, 1998). Araştırmada kullanılan değişkenler, genel akademik ortalama, öğrencilerin puanlama yöntemi ile belirlenen öğrenme stilleri ve proje performans puanlarıdır Araştırmada korelasyon türü ilişki arandığından,

değişkenlerin birlikte değişip değişmedikleri, birlikte bir değişim varsa bunun da ne şekilde olduğu tespit edilmeye çalışılmıştır. İki değişken arasında bir ilişkinin olup olmadığı anlamlılık sınamaları ile belirlenir. Çözümleme sonucunda bulunan değer, şans dışında sistemli bir etkileme ya da etkilenme ile oluşmuş görünüyorsa ilişki var demektir. Değişkenler birlikte artan ve azalan değerler alıyorsa ilişki artı (+) yani yönde, değişkenlerden biri artarken diğeri azalıyorsa ilişki eksi (-) yani negatif yöndedir (Karasar, 1998).

Çalışma Grubu

Araştırmanın çalışma grubunu bir üniversitenin Genel Fizik I Laboratuvar dersini alan 80 fen bilgisi öğretmen adayı oluşturmaktadır.

Veri Toplama Araçları

Araştırmada Fen bilgisi öğretmen adaylarının öğrenme stillerini belirlemek amacıyla Grasha ve Riechman (Grasha, 1996) tarafından geliştirilen Grasha-Riechman öğren-me stilleri ölçeği kullanılmıştır. Ölçek Uzuntiryaki, Bilgin ve Geban (2003) tarafından Türkçeye çevrilerek adapte edilmiş ve 330 lise öğrencisine uygulanarak güvenilirlik kat sayısı 0.794 olarak bulunmuştur. Ölçek, rekabetçi, iş birlikli, pasif, katılımcı, bağımlı ve bağımsız alt boyutları olan ve her boyutta on olmak üzere beşli likert tipi altmış cümleden oluşmaktadır. Grasha (1996) öğrenme stili envanterindeki sonuçlara göre öğrencilerin “bağımlı/pasif/katılımcı/rekabetçi”; “katılımcı/bağımlı/iş birlikli”; “iş birlikli/katılımcı/bağımsız” ve “bağımsız/iş birlikli/katılımcı” öğrenme stilleri olmak üzere dört kategoride gruplandırabileceğini belirtmiştir. Ancak bu araştırmada Grasha’nın belirttiği bu sınıflama kullanılmamıştır. Öğrencilerin farklı öğrenme stillerinin bir karışımına sahip olabileceği fakat bir stilin diğerlerine göre daha baskın olabileceği düşünülürse bu çalışmada da öğrenme stili envanterinden elde edilen puanlar ışığında baskın görünen öğrenme stili kullanılmıştır.

Öğrencilerin oluşturdukları projeleri değerlendirmek için Bahar (2009) tarafından Mini projeleri değerlendirmek geliştirdiği dereceli puanlama anahtarı kullanılmıştır. Dereceli puanlama anahtarı temel alınarak oluşturulan projeler 100 puan üzerinden değerlendirilmiştir. Genel akademik puanları, öğrencilerin aldıkları tüm derslere ilişkin genel not ortalamalarıdır.

BULGULAR

Araştırma sorularına yönelik ortaya çıkan bulgulara bakıldığında; araştırmanın birinci alt problemi için farklı öğrenme stillerine sahip olan öğrencilerin proje performans puanları arasında farka yönelik Varyansların Homojenliği (Levene) ve ANOVA testlerine ait sonuçlar Tablo 2 ve Tablo 3’te sunulmuştur.

Tablo 2. Farklı Öğrenme Stillerine Sahip Olan Öğrencilerin Proje Performans Puanları Arasında Farka Yönelik Levene Testi Sonuçları

Levene	Sd1	Sd2	p.
1,65	4	75	,17

Tablo 3. Farklı Öğrenme Stillerine Sahip Olan Öğrencilerin Proje Performans Puanları Arasında Farka Yönelik ANOVA Testi Sonuçları

Öğrenme Stili	n	X	SS	F	p	Fark Stiller
Bağımsız	7	77,85	9,06			
Yarışmacı	14	74,64	8,42			
Bağımlı	28	75,17	7,26			
İşbirlikçi	11	86,81	4,62	5,68	0,00*	Yarışmacı - İşbirlikçi Bağımlı-İşbirlikçi Katılımcı - İşbirlikçi
Katılımcı	20	77,75	7,15			
Total	80	77,56	8,15			

Farklı öğrenme stillerine sahip fen bilgisi öğretmen adaylarının proje performans puanları arasında anlamlı bir fark bulunmuştur [$F(4,75)=5,68$, $p<0,01$]. Proje performans puanları arasında fark görülen gruplara bakıldığında; bu farkların yarışmacı-işbirlikçi, bağımlı- işbirlikçi ve katılımcı- işbirlikçi öğrenme stillerine sahip öğretmen adayları arasında olduğu görülmektedir. Farklılığın yönünün ise işbirlikçi öğrenme stiline sahip öğrenciler lehine olduğu görülmüştür.

Araştırma sorularına yönelik ortaya çıkan bulgulara bakıldığında; araştırmanın ikinci alt problemi için farklı öğrenme stillerine sahip olan öğrencilerin akademik başarı puanları arasında farka yönelik Varyansların Homojenliği (Levene) ve ANOVA testlerine ait sonuçlar Tablo 3 ve Tablo 4'te sunulmuştur.

Tablo 3. Farklı öğrenme stillerine sahip olan öğrencilerin akademik başarı puanları arasında farka yönelik Levene testi sonuçları

Levene	Sd1	Sd2	p
0,86	4	75	,49

Tablo 4. Farklı Öğrenme Stillerine Sahip Olan Öğrencilerin Akademik Başarı Puanları Arasında Farka Yönelik ANOVA Testi Sonuçları

Öğrenme Stili	n	X	SS	F	p
Bağımsız	7	2,21	0,55		
Yarışmacı	14	2,13	0,44		
Bağımlı	28	2,23	0,34	0,84	0,50
İşbirlikçi	11	2,29	0,28		
Katılımcı	20	2,36	0,37		
Total	80	2,25	0,38		

Farklı öğrenme stillerine sahip fen bilgisi öğretmen adaylarının akademik başarı puanları arasında anlamlı bir fark görülmemiştir [$F(4,75)=0,84$, $p>0,05$]. Bu bağlamda öğrenme stili adayların akademik başarıları ortalamalarını doğrudan etkilememiştir.

TARTIŞMA ve SONUÇ

Araştırma sonuçlarına göre; farklı öğrenme stillerine sahip fen bilgisi öğretmen adaylarının proje performans puanları arasında anlamlı bir fark olduğu görülmüştür. Fark görülen gruplara bakıldığında; bu farkların yarışmacı-işbirlikçi, bağımlı- işbirlikçi ve katılımcı- işbirlikçi öğrenme stillerine sahip öğretmen adayları arasında olduğu görülmektedir. Farklılığın yönünün ise işbirlikçi öğrenme stiline sahip öğrenciler lehine olduğu görülmüştür. Bu bağlamda işbirlikçi öğrenme stiline sahip öğrenciler gruplar şeklinde yürütülen proje çalışmalarında daha başarılıdır denebilir. Doymuş, Şimşek ve Bayrakçeken (2004)'e göre; işbirlikçi öğrenme stiline sahip öğrenciler “ araştırma yapma”, “zamanı iyi kullanma”, “rapor hazırlama” ve “ organize etme ve planlama” gibi konularda diğer öğrencilere göre öne çıkmaktadırlar. Bu noktadan hareketle bu işbirliğine yatkın öğrenciler hem başarı, hem de öğrenmeye ve konuya karşı tutumlarına olumlu yönde katkı sağlayabilmektedir. Bu aynı zamanda performansa da yansımaktadır.

Araştırmanın ikinci alt probleminde ele alınan farklı öğrenme stillerine sahip fen bilgisi öğretmen adaylarının akademik başarı puanları arasında farka bakıldığında, bu farkın anlamlı bir fark olmadığı görülmüştür. Bu bağlamda öğrenme stillerinin öğretmen adaylarının genel akademik başarılarını etkilemediği görülmektedir. Her iki alt problemleri birlikte ele aldığımızda, öğrenme stillerinin performans ve süreç odaklı çalışmalarda bireyin başarısını etkilediği görülmektedir. Bu başarının işbirlikçi öğrenme stili lehine olması da; başkalarıyla çalışmaktan hoşlanan ve etkileşim içinde olan bireylerin daha iyi performans gösterdiklerini göstermektedir. Akademik başarının ölçülmesinde lisans eğitiminde sıkça kullanılan ölçme yöntemleri bu bağlamda irdelenmelidir.

Öğrenme stillerinin öğretme-öğrenme sürecinde işe koşulmasında; öğrenenlerin öğrenme stilleri hakkında yeterince bilgi sahibi olunması çok önemlidir. Bu bilgilendirme de belki de en önemli şey bireysel farklılık noktasında ele alınan tüm özelliklerle ilgili uygulamalarda ortaya çıkan sonuçların “değişmez, sınırları kesinlikle belli, bu öğrenci şu stile sahip bu nedenle kesinlikle şu şekilde öğrenir” tarzındaki genellemeleri terk etmektir. Bunun yerine tüm bu bireysel farklılıkları “şu yönde eğilimi var, bu alanda kendini daha da geliştirebilir ama şu alanda da desteğe ihtiyacı var” tarzındaki destekleyici ve cesaretlendirici yönlendirmelerle yapmak olmalıdır.

Araştırma sonucunun gösterdiği doğrultuda, öğrenme stili özellikle grupla çalışma sürecinde ve performans düzeyinde etkilidir. Akademik başarı ortalaması bağlamında ise ölçme araçları değişkeninden dolayı bu etki gözlenmemiştir.

ÖNERİLER

Bu araştırmanın daha geniş bir örneklem grubunda tekrarlanarak açık uçlu görüşmelerle desteklenmesi, öğretmenlerin sınıf içerisinde izledikleri öğretim stillerinin gözlenebilmesi, öğretme ve öğrenme stilleri arasındaki ilişkinin biraz daha iyi anlaşılabilmesi açısından da yararlı olacaktır. Öğrenme stili bireylerin öğrenmeye olan yaklaşımlarını ve öğrenirken izledikleri yolu göstermesi açısından önemlidir. Öğrencilerin öğrenme stilleri konusunda bilgi sahibi olunması, önceden belirlenmiş öğrenme hedeflerine ulaşırken izlenecek yola ışık tutacaktır.

KAYNAKLAR

- Al-Naeme, F. F. A. (1991). The influence of various learning styles on practical problem solving in Scottish secondary schools. Unpublished doctoral thesis, Glasgow University, Glasgow, Scotland.
- Aşan, A., Haliloğlu, Z. (2005). Implementing Project Based Learning in Computer Education. 12.01.2014 tarihinde <http://www.tojet.net/articles/4310.doc> adresinden edinilmiştir.
- Bahar, M. (2009). Öğrencilerin Öğrenme Stilleri ve Mini Fen Proje Çalışmalarındaki Performans Arasındaki İlişki. *Educational Sciences: Theory & Practice* 9 (1)
- Balkı, A., G. (2003). Proje Temelli Öğrenme Yönteminin Özel Konya Esentepe İlköğretim Okulu Tarafından Uygulanmasına Yönelik Bir Değerlendirme. Yüksek Lisans Tezi. Selçuk Üniversitesi Sosyal Bilimler Enstitüsü İlköğretim Anabilim Dalı. Konya.
- Dunn, R., & Dunn, K. (1993). Teaching secondary science students through their individual learning styles: Practical approaches for grades 7-12. Allyn and Bacon: USA.
- Johnstone, A. H., & Al-Naeme, F. (1995). Filling a curriculum gap in chemistry. *International Journal of Science Education*, 17, 219-232.
- Johnstone, A. H., & Al-Shuaili, A. (2001). Learning in the laboratory: Some thoughts from the literature. *University Chemistry Education*, 5 (2), 42-51
- Jonassen, H. D. & Grobowski B.L. (1999) *Handbook of Individual Differences, Learning and Instruction*. USA: Lawrence Erlbaum Associates.
- Kapenda, H. M., Kandjeo-Marenga, H. U., & Kasanda, C. D. (2002). Characteristics of practical work in science
- Karasar, N. (1998). *Bilimsel Araştırma Yöntemi -Kavramlar, İlkeler, Teknikler-*, Nobel Yayın Dağıtım, 8. Basım, Ankara
- Keefe, J. W. (1991). *Learning style: Cognitive and thinking skills*. Reston, VA: National Association of Secondary School Principals.
- Kolb, D. A. (1984). *Experiential learning: Experience as the source of learning and development*. Englewood Cliffs, N.J: Prentice-Hall.
- Korkmaz, H. (2002). Fen Eğitiminde Proje Tabanlı Öğrenmenin Yaratıcı Düşünme, Problem Çözme ve Akademik Risk Alma Düzeylerine Etkisi. Doktora Tezi. Hacettepe Üniversitesi Sosyal Bilimleri Enstitüsü Eğitim Bilimleri A.B.D. Ankara
- Montgomery, S. M., Groat, L.N. (2004) "Student Learning Styles and Their Implications for Teaching" 26. 03. 2014 tarihinde <http://www.serprofessoruniversitario.pro.br/ler.asp?TEXTO=428> adresinden edinilmiştir.
- Morris, S. ve McCarthy, B. (1990). *4MAT in Action II: Sample Lesson Plans for Use with the 4MAT System*. Barrington: Excel, Inc.
- McCarthy, B. (2000). *About Teaching 4MAT in the Classroom*. Wauconda, IL: About Learning, Inc.
- Özer, B.(2001). "Öğrenmeyi Öğretme", Öğretimi Planlama ve Değerlendirme II. Editör: Mehmet Gültekin. Eskişehir: Anadolu Üniversitesi Yayınları, ss. 161-174.
- Riding, R., ve Rayner, S.(1998) *Cognitive Styles and Learning Strategies - Understanding Style Differences in Learning and Behaviour-* London: David Fulton Publishers.
- Thomas, J.(2000). A Review of Research on Project Based Learning. 13.02.2014 tarihinde <http://ctl.stanford.edu/Newsletter/Problem-based-learning.pdf> adresinden edinilmiştir.
- Uzuntiryaki, E., Bilgin, I., & Geban, O. (2003, March). The effect of learning styles on high school students' achievement and attitudes in chemistry. Paper presented at Annual meeting of National Association Research in Science Teaching, Philadelphia, Pennsylvania, USA

THE EXPLORATION OF QUICK POLLS QUESTIONS' LEVELS WITH THE BLOOM'S TAXONOMY: A CASE STUDY

Sevket Ceyhun CETIN
Texas Tech University

Memet T. BULUT
Grand Valley State University

Questioning has been identified as a crucial aspect of teachers' work (Boaler & Brodie, 2004). In traditional classrooms, the common form of questions is open-ended questions that are asked by teachers and answered by students. With the development of technology, the increasing integration of handheld devices into mathematics classrooms has provided mathematics teachers an opportunity to pose different types of questions more than open-ended ones. *Texas Instrument (TI) Navigator System* with *TI N-spire Computer Algebra System (CAS)* is one of the handheld devices that began to be widely used across the US nation. The *Quick Poll (QP)* feature of the system provides teachers an opportunity to ask questions (as called QP questions) and collect students' responses instantly. Numerous studies have been conducted to show how the system increases students' engagement and participation by allowing all students to answer asked questions. However, there is a gap in the literature in terms of assessing the difficulties of QP questions. The qualitative intrinsic case study (Stake, 2005) was intended to close the gap in the literature and answer the following overarching research question; What are the relationships among the levels of QP questions, lesson objectives, and lessons' "I can statement?" To fulfill the aim, three middle school mathematics teachers' videotaped lessons were observed, the QP questions were recorded, and the questions and "I can statement" of the three lessons were classified based upon the Bloom's Taxonomy. The findings of the present study showed that whereas the "I can statement" of the lessons were set at high levels, such as, analysis, synthesis levels, the levels of QP questions were at low level, such as, application, comprehension. Previous studies about teacher questioning concluded the same result that teachers ask low levels and more factual questions (Myhill & Dunkin, 2002; Sahin & Kulm, 2008). Very few number of QP questions in total were at high levels and the number of students who answered the questions correct was less than the number of students who answered the low questions correct. According to the findings of the study, in-service middle school mathematics teachers need professional development on how to formulate their regular questions and QP questions. Additionally, coordinators and administrators of pre-service mathematics teacher preparation programs may need to evaluate their undergraduate and graduate activities in terms of questioning to make the changes for their programs as needed.

REFERENCES

- Boaler, J., & Brodie, K. (2004). The importance, nature, and impact of teacher questions. In D. E. McDougall & J. A. Ross (Eds.) *Proceedings of the twenty-sixth annual meeting of the North American Chapter of the International Group for the Psychology of Mathematics Education* (pp. 774-782). Toronto, Ontario, Canada: Ontario Institute for Studies in Education of the University of Toronto.
- Myhill, D., & Dunkin, F. (2002). What is a good question? *Literacy*, p. 8.
- Sahin, A., & Kulm, G. (2008). Sixth grade mathematics teachers' intentions and use of probing, guiding, and factual questions. *Journal of Mathematics Teacher Education*, 11(3), 221-241.
- Stake, R. E. (2005). Qualitative case studies. In N. K. Denzin & Y. S. Lincoln (Eds.), *The SAGE handbook of qualitative research* (2nd ed.), (pp. 443-466). Thousand Oaks, CA: Sage.

CONTINUING TEACHER EDUCATION COURSES OF COMPUTATIONAL RESOURCES IN THE TEACHING OF MATHEMATICS AND PHYSICS: CREATION, APPLICATION AND STUDY

Italo Gabriel NEIDE
Centro Universitário UNIVATES
italo.neide@univates.br

Maria Madalena DULLIUS
Centro Universitário UNIVATES
madalena@univates.br

Marli Teresinha QUARTIERI
Centro Universitário UNIVATES
mtquartieri@univates.br

ABSTRACT: Research indicates that the use of the computer can become an ally in the cognitive development of students, allowing them new ways of thinking and acting. However, this potential has not yet been fully integrated into everyday Brazilian school practice. Considering this context, we aimed to investigate how continuing teacher education courses, involving the use of computational resources in the processes of teaching and learning of Mathematics and Physics can impact the pedagogical practice of teachers. We have developed and are executing two projects with interconnected actions, allowing the oriented work with several teachers and international collaborators. The main objective is the inclusion of computational resources in the processes of teaching and learning. The main expected results is that the actions developed will stimulate and encourage more teachers to use technology in their classrooms, allowing students to experience new experiences in Mathematics and Physics.

Key words: computational resources continuing education, teaching

INTRODUCTION

The impact and advance of digital technologies are increasingly affecting all aspects of lives of the people. This leads to transformations on the social, economic and technological areas resulting in the need of new forms of teaching and learning in the field of education. In order to meet new demands, educational institutions have sought to integrate technological resources in the practice of teachers. However, only the presence of technological resources in teaching practice is not a guarantee to a higher quality in education, because the simple use of these resources can serve as camouflage for a teaching based on mere reception and reproduction of information. The incorporation of these resources in the school context requires study regarding the use of these tools as mediation between the individual and the knowledge. According to Sangari (2007):

... it is up to the educator to contribute to the education of this generation mediated by information and communication technologies, increasing the dynamism and interactivity in educational processes, creating methodologies that enable the development of epistemological curiosity of our students, in order to promote skills that prepare them for a world of constant and rapid change. (p.20, our translation)

It is noted that students are increasingly involved with technology, have curiosity and are in daily contact with them. In this sense, it calls for the teacher to use these resources in their pedagogical practice. For Bortolotti (2008), “the presence of technology in the classroom, especially with regard to the use of computers, requires new attitudes across the teaching and learning process of the educational institutions and teachers” (p. 9, our translation). Regarding the interaction of teachers with technological resources, Richt (2010) indicates that:

The introduction of changes in the educational scenario reinforces the need for coordination between teacher education programs and initiatives that propose the use of technology in the processes of teaching and learning. To this end, professionals of education need to interact with these resources, exploring them in a critical and investigative way, reflecting about the use of these in the classroom, and thus to develop a review about the mutability of knowledge concerning technologies and pedagogical changes raised by this dynamics. (p. 73, our translation)

For the use of technology in the processes of teaching and learning, Demo (2009) points that teachers need to be more careful, because it is not possible to do a renovated school with traditional teachers. He says that nothing new will happen with students if teachers do not know how to learn with technology, so it is crucial to prepare them for this task. The author comments that the teacher, to continue learning, can transform your classroom into a laboratory or in a context that challenges him to develop new ways of teaching and learning. In this sense, the author warns:

Most probably the final diploma will end, entering in its place something temporary. The increasingly frantic race by professionals aiming update academic qualifications proves that their diplomas dried.

It may be possible to keep the door always open for the reconstruction of the diploma, within the idea that it is essential to become a lifetime member of the university community of learning. (DEMO, 2009, p. 73, our translation)

In this context, professionals working in the area of education, even if they have already attended initial education, they will need continuing teacher education. It should be emphasized that continuing education are all actions taken by teachers to improve their teaching, such as lectures, workshops, short courses and / or moments of reflection. Regarding the continuing education of teachers, Ferreira (2009) points that this is a field often researched in academia, however there is a large gap between the aim of the training offered to teachers and what are their true needs. Nóvoa (2014) points that for such continuing education to be organized around concrete and specific situations, that promote the desire to find a solution to solve them and stresses the importance of knowledge beyond theory and practice. The author indicates the search for a knowledge that is relevant and not just a practical application of any theory, and suggests designing their continuing education in a professional commitment environment, providing attention to changes in work routines, personal, collective or organizational.

In this context, to insert a new tool in the classroom implies pedagogical changes, changes regarding the vision of teaching, which should be studied and considered by teachers. Thus, some questions may be considered: How to effectively integrate the computer in the processes of teaching and learning? What aspects should be considered when choosing a computer application? What software explore in pedagogical practice? How to prepare teaching activities using technological resources? What activities can be explored using these tools? How to organize the computer lab? These and other questions arise for teachers. These are the questions that permeate the investigations of the authors of this work. The authors are professors of Centro Universitário UNIVATES, located in the south of Brazil. The authors also compose a research group with more members: professors, students of scientific initiations, volunteers, students enrolled in the Post Graduate Program in Exact Sciences and teachers. The aim of the research group is to provide contributions to answer the questions above applied in the area of exact sciences, more precisely in the teaching of Mathematics and Physics. For this purpose, the group has already published works, and the progress culminated in the creation of continuing education courses. Their applications are related by Quartieri, Dullius and Bergmann (2013a), and Quartieri, Dullius and Bergmann (2013b) in two participations of conferences in the area, and insights on the results are related by Dullius, Quartieri, Bergmann and Faccio (2012) in other conference.

Currently, the Brazilian government initiated a series of actions in the education. Some of them contemplate proposals with grants for those that are considered relevant for the actual processes of teaching and learning. Currently our group has four projects granted, and two of them are related directly with the subject of this work. In the following sections their methodology and expected results will be related, as well as the progress of the works.

METHODS

In this section it will be described a resume of the methodologies of two researches: Work I and Work II. Both works have qualitative and quantitative approaches and they were idealized to have participation of teachers of basic education. They will be the subjects of the new continuing teacher education courses and the performers of the new practices on the classroom. The research are based to be centered in students and in teachers, so it is natural to expected regular participation of teachers.

Work I

The principal aim of the first work is to study the possibilities of utilizing computational resources in the processes of teaching and learning of Mathematics and Physics in the Brazilian school. More specifically, there is a government strategy to integrate tablets in basic education, so this research is polarized to study tablets as a tool in the pedagogical practice.

The methodology consists to promote meetings with teachers of basic education that are motivated to think and study the use of computational resources in classroom. The meetings will consist of discussions about the possibilities of the use of tablets and software and to create pedagogical activities for the practical intervention in the classroom. During the process, the authors will be constantly evaluating the proposal, the impact in the pedagogical practice of teachers, as well as the difficulties faced by the teachers. The authors pretend to investigate these subjects via interviews, reports and recordings of the interventions.

Work II

The second work consists in exchange international pedagogic experience by collaborating with research groups from outside Brazil. The main proposal of this work is to become familiarized with different views of education, more specifically in how digital technologies are used to contribute in the processes of teaching and learning of Mathematics and Physics. This research was proposed in conjunct with a Portuguese professors group from Universidade do Algarve. Since in the past there were some opportunities to meet them and their subjects of study were connected with the work of the authors of this paper, this union naturally emerged

The first action consists of a work mission of the Brazilian and Portuguese professors in schools of basic education in Algarve to a process for acquiring data that encompasses the following activities: observations of how classroom are conducted by Portuguese teachers, interview with teachers and distinct members that participates in continuing teacher education courses, interviews with students of the investigated classes, case studies and documental data of the investigation realized by the Portuguese professors. All this steps are to be repeated in Brazil with the Portuguese group. The visit in Portugal is directed to acquire knowledge about the reality of the integration of digital technologies in the classroom in this country, to experiment new pedagogical practices situations and to connect and apply useful ideas in the Brazilian research studies to create contributions in teaching innovations.

EXPECTED RESULTS

It is plausible to assume that the first work will originate rich discussions with the teachers, making possible the creation of several technical productions aimed at how to use tablets in the teaching of specific subjects of Mathematics and Physics. Once they are produced, their union may become a book that will be distributed in schools of the authors neighborhood educational institution and also an e-book to maximize its reach. Besides that, the meetings will provide foundations for the creation of a continuing teacher education courses in digital technologies for teachers of basic education that can be offered to qualify their practice.

The second work have potential to expand and confront the authors view of education. Knowing different realities and performing research with different cultures are a promising way to provide deep changes in the understanding of how people can learn. Since the authors will be in loco with the Portuguese collaborators, in both countries, some possibilities naturally rise: the mutual aggregation of important aspects of the distinct processes of teaching and learning, description and understanding of interconnections between the two educational views, interpretation of a different perspective of observation from distinct cultures and the production of pedagogical materials based in the previous points aimed to innovate and challenge teachers in a positive way to provoke them to search qualification in this area.

CONCLUSION

Both works walk side by side, and their main objectives share important aspects. At the end of the two researches, the authors believe that the studies with the teachers, the international collaboration and the new pedagogical materials will have the potential to qualify the exploration of computational resources in the processes of teaching and learning, as well as to report the advantages and disadvantages and problems regarding the use of these materials. Furthermore the authors expect that the participant teachers of the research feel safe, challenged and motivated to utilize computational resources in their classroom as an auxiliary tool in their pedagogical practice, providing to the students a new experience of learning in Mathematics and Physics, motivating them to an active participation in this process.

REFERENCES

- Bortolotti, N. (2008). O computador e a disciplina de matemática [The computer and the Mathematics course]. *UEL*. Retrieved April 30, 2014 from http://www.gestaoescolar.diaadia.pr.gov.br/arquivos/File/producoes_pde/artigo_nivaldo_bortolotti.pdf

- Demo, P. (2009). *Educação hoje: “novas” tecnologias, pressões e oportunidades* [Education today: “new” technologies, pressures and opportunities]. São Paulo: Atlas.
- Dullius, M. M., Quartieri, M. T., Bergmann, A. B. & Faccio, T. A. P. (2012, June). *A formação continuada de professores e o uso de Recursos Computacionais no Ensino* [The continuing teacher education and the use of Computational Resources in the Teaching]. Paper presented at the 3º Simpósio Internacional de Pesquisa em Educação Matemática, Fortaleza, Brazil.
- Ferreira, J. W. S. (2009). *Grupo EMFoco: diferentes olhares, múltiplos focos e autoformação continuada de educadores matemáticos* [Group EMFoco: different views, multiple focus and continuing ownformation of mathematics educators]. São Paulo: Editora Livraria da Física.
- Nóvoa, A. (2014). Para uma formação de professores construída dentro da profissão [For an education of teachers constructed inside the profession]. *Revista de Educación*, 350, 09-20. Retrieved April 30, 2014 from www.revistaeducacion.mec.es/re350/re350_09por.pdf
- Quartieri, M. T., Dullius, M. M. & Bergmann, A. B. (2013a, July). Curso de formação continuada proporcionando inserção de recursos computacionais em aulas de Matemática [Continuing teacher education courses to contemplate the insertion of computational resources in Mathematics courses]. Paper presented at the XI Encontro Nacional de Educação Matemática, Curitiba, Brazil.
- Quartieri, M. T., Dullius, M. M. & Bergmann, A. B. (2013b, September). Formação continuada para professores de Matemática dos Anos Finais do Ensino Fundamental proporcionando a inserção de recursos computacionais [Continuing teacher education in Mathematics for Final Years of Fundamental Education to contemplate the insertion of computational resources]. Paper presented at the VII CIBEM - Congreso Iberoamericano de Educación Matemática, Montevideo, Uruguay.
- Richt, A. (2010). *Apropriação do Conhecimento Pedagógico-Tecnológico em Matemática e a Formação Continuada de Professores* [Appropriation of Technological-Pedagogical Knowledge in Mathematics and Continuing Teacher Education]. (Doctoral dissertation). Instituto de Geociências e Ciências Exatas, UNESP, Brazil.
- Sangari, B. (2007). A tecnologia como aliada do desenvolvimento da educação [Technology as an ally of the development of education]. *Linha Direta – Educação Por Escrito*, 114, 20-26.

A PROBLEM GENERATOR SYSTEM TO LEARN FIRST-DEGREE EQUATIONS

Mir Mohammad Reza ALAVI MĪLANI

Karadeniz Technical University, Computer Engineering Department, Trabzon, Turkey
milani@ktu.edu.tr

Hüseyin PEHLIVAN

Karadeniz Technical University, Computer Engineering Department, Trabzon, Turkey
pehlivan@ktu.edu.tr

Sahereh HOSSEINPOUR

Karadeniz Technical University, Computer Engineering Department, Trabzon, Turkey
hoseinpour@ktu.edu.tr

ABSTRACT: Problem-based learning enhances academic productivity, and improves long-term memory. Thus it is better than traditional instruction. Meanwhile, the teaching of mathematics education is more important than others. Much software is developed for visual learning mathematics, but there is a great need for problem-based systems. This is more visible, due to the increasing proliferation of e-learning education. On the other hand, first degree equations are a uniquely important topic in high school and collage algebra classes, for the simple reason that mastery of a preponderance of later topics requires a student's ability to solve these equations. Such topics include absolute value equation, equation containing fractions, radicals, and an abundance of applications. Proficiency at solving first degree equations in one variable is literally essential to success in an algebra class. Students often do not clearly understand the concepts of these topics and make mistakes when they write homework's or use these concepts in the other topics. In order to help the students to learn these concepts by solving problems, we have proposed a system that generate problems and evaluate learner's answers. In this paper we propose a methodological approach for automatic solving of mathematical equations, especially in terms of the first degree equations in one variable, with the aim of the practicing of mathematics subjects, by using of Computer Algebra System (CAS) tools. The paper also addresses some specific fields such as the simplification and automatic production of mathematical equations.

Key words: First-degree equation, Problem-based learning, Computer Algebra System, Problem generator, Problem solver

INTRODUCTION

According to the research conducted, it can be argued that the problem-based learning is more effective than traditional learning, and increase students' ability to solve the problems (Farnsworth 1994) On the other hands textbooks cannot be suitable as a source of questions, because they are limited, and not Interactive. Also, textbooks do not usually solve the problem step by step and don't have appropriate visual features for motivation. In these resources, often there aren't facilities for on line helps to students. Therefore, Use of information and computer-based technologies in education, specially physics (e.g.,CAPA) (Kashy *et al.* 1993), mathematics (e.g., Mathway) (Dragon, T *et al.* 2013; Gutierrez-Santos S. *et al.* Oct.-Dec. 2012) or electronics (e.g., CHARLIE) (Barker, 1997) is widespread. Also can be seen that emerged systems for generating and solving the questions (Wolfram 2011, Bridgeman *et al.* 2000; May 2000; Baldwin, 1996)

Also, due to the importance of mathematical education and necessity to produce numerous questions on different topics in this subject, the importance of using Computer Algebra System (CAS) in this section can be shown. Creation infrastructure for the production of educational software in mathematics, studies on this type of software production methods and production and implementation of software for mathematics education is the future cases that should be considered by such topics scholars.

In this article, we will describe a system that is designed to teach the first degree equations in mathematics. This system has two parts: Tutorial and Test, and with taking deferent levels generate any questions automatically and gives to users. Step-by-step solving of generated problems, and guidance to the user, in order to correctly solve the problem are the other facilities of this system.

We used java programming language in design of our system. Because of this language is independent from operating systems and can be used in all devices and even the Internet. Also we used JavaCC for parsing of mathematical expression. The proposed system can be used as part of the personalized educational system or used in the e-learning systems as a tool for practice and self-examination.

In the next sections we will discuss more about methodology and generate of first-degree equation parse tree using JavaCC. Also we will dedicate to our automatic procedure for generating first-degree equations. Then, we demonstrate the user interface and educational plan for our proposed method.

METHODS

Proposed Method

For implementation of proposed system, the following three sections will be designed

- Production of first-degree equations
- Solving of first-degree equations
- Designing of User Interface and Appropriate Plan

Equations should be randomly generated with considering level of difficulty in its. Also, for obtaining the result of equation and to get a user guide, we need to create parse tree and automatically solving by the computer.

Below, each of the sections will be explained in detail.

Equation Generation

Discussed system generates an equation as a binary tree. The terminal nodes of the tree contain *Num* or *Var* operands and non-terminal nodes contains *Plus* or *Times* operator. Algorithm of tree generation is recursive and based on grammars that shown in list1.

```

S   → E = E
E   → E + E | Num | Var
E   → E * E' | E' * E
E   → ( E )
E'  → E' + E' | E' * E' | Num
E'  → ( E' )
Num → [0-9]*
Var → 'x'

```

List1. CFG Grammar for First degree Equation Generation

Using the rules in list1, we can obtain infinite equation. Figure 1 show one example of generated equation in tree structure.

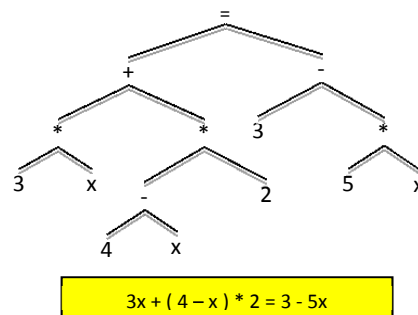

Figure 4 Example of an equation that generated by grammar in list1

According to rules of grammar in list1, the size of generated equations is purely randomly and may be very long. To solve this problem, we can be assigned a certain value as probability for each rules of grammar. The value of some rules will be increase or decrease associated with the level of nodes in tree. Qua the probabilities of terminal nodes will be increased and the probabilities of non-terminal nodes will be decreased. Thus with increasing the size of tree, probabilistic of generating terminal node will be increase too.

Notice that, to generate equations with specific complexity, we can use parameters for increase/decrease of probabilities amount. Thus in system we can get degree of difficulty from users and generate desired equations. Generated equation can be stored in a database or displayed to the user. For obtain the string of equation from tree, we must be traversed tree in in-order like fashion. Consider that the equation is evaluated by traversing of

original tree thus we should have already saved a copy of the tree. Also, the intermediate results are stored in the nodes of the tree and used to check the user's answer. The x-coordinate of the operands are also stored in the nodes, and are used to verify the under braces in user's answer.

Equation Solving

In this paper, a CAS-like system is presented for the step-by-step solution of problems. The core calculation mechanism of the system, which is based on symbolic calculation techniques, can be coded by using a Java-like programming language. The input data of the system are textual expressions used for the representations of mathematical problems, which can be parsed via a compiler-compiler tool such as JavaCC.

In this paper we present a method to calculate the first-degree equation symbolically by using the common tools of compiler designs as well as utilizing the CAS methods. Before addressing how it is done, however, first the equations received from the user should ideally be examined in terms of the verified entry (the rules related to a first-degree equation) and the resulting process should be transformed to a tree structure known as parse tree. Therefore, we examine the suggested system in separate phases with the following:

Parse Tree Construction

The general form of an expression is grammatically defined using a context-free grammar (CFG). Since JavaCC generates LL (k) parsers, this grammar must be LL (k) one. The design of a scanner and parser is based on the lexical and phrase structure of mathematical expressions. Thus, a CFG grammar is developed to recognize and parse such equations. In addition to the form of the input data the grammar must also represent the appropriate priority level and associativity of operators. This task is followed by the conversion of the grammar to the LL(k) one. The resulting LL(1) grammar is shown in Table 1.

A scanner splits the input data into a sequence of tokens which are the atomic parse elements of that input data.

Table 1: An LL (1) grammar for first-degree equations.

Rule	Method
$S \rightarrow E "=" E \$$	parse()
$E \rightarrow ("+" "-")? T E'$	expr()
$E' \rightarrow ("+" "-") T E' \lambda$	
$T \rightarrow \text{Num} ("x")? "x" (\text{Num})?$	term()
$\text{Num} \rightarrow (D)+ ("." (D)+)?$	
$D \rightarrow ["0"- "9"]$	

Simplification

The next task is the simplification of the resulting tree, which is one of the most important and underlying operations in symbolic computation systems. This has many difficulties in the implementation because some concepts of simplification are naturally challenging. For example, responding the question "which of the states shown in the following figure is simplified?" justifies this claim.

In this step, reusing the tree obtained from the previous step, all nodes associated with the tree are visited again; this time the simplification operations are performed for every node. For example, if visited node has an operator +, which is connected to two child nodes with numbers, the sum of these two numbers are returned as the simplified form of the node. The Figure 2 represents this example.

```

if OpNode instanceof Pluse then
  If RChild and LChild instanceof Num then return Num(RChild.val()+LChild.val())
End if

```

Fig. 2 Pseudo-code for a node with two Num child

In the above state, if both child nodes are of the same variable, the addition operation can be done as Figure 3. Note that, in the Figure 3 pseudo-code, the class *Var* is used as a variable, and the coefficient of variable x is placed inside the *Var* objects. For example, *Var(3)* is used to represent the expression 3*x. The simplification stage can encounter some particular expressions. To illustrate this, let us consider more complex expressions represented by a tree such as

Plus(Var(5), Plus(Num(3), Var(2)))

The represented expression is $5*x+3+2*x$. Since the child nodes are not of the same type, the parent one is not able to simplify, while the expression is equivalent to the simplified one $7*x+3$, represented by

$Plus(Var(7), Num(3))$. This problem can be resolved by the transformation of the binary tree into multiple one and then applying the simplification. Figure 1 shows the case graphically. In this way, the simplifying function can generate the simplest form of the expression.

```

if OpNode instanceof Plus then
    If RChild and LChild instanceof Num then
        return new Num(RChild.val()+LChild.val())
    If RChild and LChild instanceof Var then
        return new Var(RChild.val()+LChild.val())
End if

```

Fig. 3: Pseudo-code for a node with two *Num* or *Var* Child

Presentation function

At the each stage, the equation tree should comprehensively and suitably be transformed to a mathematical expression to be represented. For this, a function should be designed that takes a tree as an input and then returns a mathematical expression related to that tree as a string. Performed by using the concepts of classes and recursive calling, by meeting every node and depending on the operator type of the node, this function generates and returns appropriate strings. Of course, it should be noticed that for representing mathematical expressions, the appropriate use of parentheses is of specific importance, which should specifically be considered in the design of the function.

First-Degree Equation Calculator

In this step, having the underlying function, a tree related to the first-degree equation solution can conveniently be created. Figure 4 show a flowchart for first-degree equation solving.

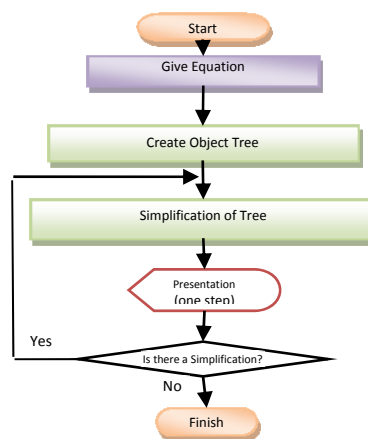

Fig. 4: Flowchart for First-Degree Equation Solving

According to the flowchart above, having received an equation from the user and having generated an initial parse tree, the simplification and presentation function must be called in each round of loop. Thus we can show step-by step solution of equation (one step in each cycle).

User Interface and Educational Plan

The user interface of proposed method can be allows the user to choose from different levels of difficulty and system will be generate equation based on specific level. The default is intermediate level of difficulty. Our system presented an equation that generated based on user’s preference of difficulty. The user is expected to solve the equation by specification and writing intermediate results. Entered intermediate answers will be evaluated by system and feedback will be display properly. To obtain appropriate results, the user may enter either the tutorial or test mode to solve the presented equation.

Tutorial Mode

In this mode, the user may operate by repeatedly clicking on the “Next Step” button. On each click, system displays a step of solution followed by the result of one simplification. Therefore, the user can observe the sequence in which equation is solved, and learn this subject.

Test Mode

In this mod, the user in order to solve the problem must enter intermediate results as describe before. The user may have her/his answer checked at any stage of solving the problem. Each stage of answer will be evaluate by system and provide a feedback to user. And if the answer is correct, user can be continuing to her/his task otherwise this stage should be repeated by user.

CONCLUSION

In this work, a CAS-based system was developed for teaching and automatically solving problems related to first-degree equation . By the step-by-step representation of a problem, students can be helped to learn this mathematical subject. Also, the possibility of generating different solutions to a problem and automatically generating a similar new problem to the problem solved can improve students, learning capabilities. So, students will be able to automatically access the infinite number of questions, without spending cost and time, and observe their different solutions step by step. This feature helps them increase their ability to solve a problem, and prepares them for tests. On the other hand, utilizing the system teachers will be able to produce and use diverse questions based on templates designed for each grade, saving time.

REFERENCES

- Baldwin, D. (1996). Three years' experience with gateway labs. *ACM SIGCSE Bulletin*, 28(SI), 6-7.
- Barker, D. S. (1997, November). CHARLIE: A computer-managed homework, assignment and response, learning and instruction environment. In *Frontiers in Education Conference, 1997. 27th Annual Conference. Teaching and Learning in an Era of Change. Proceedings. (Vol. 3, pp. 1503-1509)*. IEEE.
- Bridgeman, S., Goodrich, M. T., Kobourov, S. G., & Tamassia, R. (2000, May). PILOT: An interactive tool for learning and grading. In *ACM SIGCSE Bulletin (Vol. 32, No. 1, pp. 139-143)*. ACM.
- Bridgeman, S., Goodrich, M. T., Kobourov, S. G., & Tamassia, R. (2000). SAIL: a system for generating, archiving, and retrieving specialized assignments using LATEX. *ACM SIGCSE Bulletin*, 32(1), 300-304.
- Dragon, T., Mavrikis, M., McLaren, B. M., Harrer, A., Kynigos, C., Wegerif, R., & Yang, Y. (2013). Metafora: A web-based platform for learning to learn together in science and mathematics. *Learning Technologies, IEEE Transactions on*, 6(3), 197-207.
- Farnsworth, C. C. (1994) Using computer simulations in problem-based learning. In *proceedings of Thirty Fifth ADCIS conference, Omni Press, Nashville, TN, 137-140*
- Gutierrez-Santos, S., Geraniou, E., Pearce-Lazard, D., & Poulouvassilis, A. (2012). Design of Teacher Assistance Tools in an Exploratory Learning Environment for Algebraic Generalization. *Learning Technologies, IEEE Transactions on*, 5(4), 366-376.
- Kashy, E., Sherrill, B. M., Tsai, Y., Thaler, D., Weinshank, D., Engelmann, M., & Morrissey, D. J. (1993). CAPA-An integrated computer-assisted personalized assignment system. *American Journal of Physics*, 61(12), 1124-1130.
- Wolfram, S. (2011). *Wolfram Alpha. 2011*. URL: <http://www.wolframalpha.com>. Stand, 25

MATHEMATICS TEACHERS' VIEWS ABOUT TEACHING GENERALIZATION OF NUMBER PATTERNS

Burcu Nur BASTURK
Uludag University
bbasturk@uludag.edu.tr

Sibel YESILDERE-IMRE
Dokuz Eylul University
sibel.yesildere@deu.edu.tr

ABSTRACT: The present study reports on middle school mathematics teachers' views about teaching generalization of number patterns. Teachers' approaches to teach generalizing and their point of views on using strategies were also examined. Interviews were conducted with sixteen middle school mathematics teachers. Data qualitatively analyzed in terms of Radford's (2008) architecture of algebraic pattern generalization theoretical framework. Analysis of the data indicated that teachers' uses of representations were not effective and teachers' subject matter knowledge on generalization of number patterns is weak. It was found that teachers' commonly used strategy is trial-error. Findings also suggest that although teachers' mostly use strategies and examples in teaching process, they did not use them in order to develop students' understanding, mathematical thinking and reasoning.

Key words: generalizing number patterns, task design, task implementation

INTRODUCTION

Attention to patterns is acknowledged in its importance as an introduction to algebra (Zazkis and Liljedahl, 2002), hence constructing a conceptual understanding in students' minds is crucial. Because teaching the generalization of number patterns requires both to have specialized subject matter knowledge and purposefully constructed teaching approaches, it could be useful to use tasks within a pedagogy including the meaningful use of representations (Yesildere-Imre and Akkoc, 2012). Here one crucial aspect is the 'didactical aim' and 'pedagogical means' of the teaching process. According to Berg (2009) didactical aim is "the choice of a particular area or knowledge target within a subject-matter", and pedagogical means refers to a task "to use in order to address the chosen didactical aim" (p.100). For example, a didactical aim could be "to generalize a number pattern" and it is possible to find many different tasks used as pedagogical means to achieve this didactical aim (Berg, 2009).

Present study focuses on these both aspects of teaching generalizing number patterns process: subject matter knowledge and teaching approaches. Investigation conducted in terms of (a) teachers' subject matter knowledge about number pattern generalization and (b) teachers' pedagogical content knowledge of teaching generalization of number patterns. This will be done by relying on the theoretical framework of Radford (2008) which will be discussed in the next section.

Theoretical Framework: Algebraic Pattern Generalizations

Radford's (2008) theoretical approach to algebraic pattern generalization arose in the course of a longitudinal classroom-based research which is conducted in the 1990s. He suggested that generalizing a pattern algebraically rests on the capability of grasping a commonality noticed on some particulars (say $p_1, p_2, p_3, \dots, p_k$); extending or generalizing this commonality to all subsequent terms ($p_{k+1}, p_{k+2}, p_{k+3}, \dots$), and being able to use the commonality to provide a direct expression of any term of the sequence (Radford, 2006). Figure 1 summarizes the architecture of an algebraic generalization of patterns.

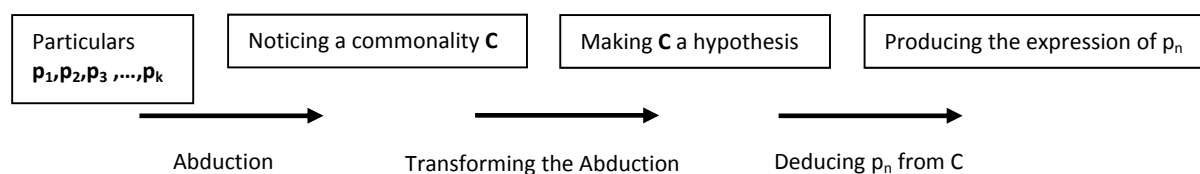

Figure 1. The architecture of algebraic pattern generalizations (Radford, 2008)

The architecture of algebraic pattern generalization framework helps us to distinguish it from other strategies that students often use to deal with patterns; In particular, it is possible to distinguish between algebraic and arithmetic generalizations of patterns (Radford, 2008). Radford underlines two other strategies that are use to generalize number patterns; arithmetic generalization and naive induction. He explains these two strategies as follows: "Arithmetic generalization comes into play when students focus on the increase in consecutive numbers or expressing the relation between the terms of the pattern with numbers. If the abductions did not lead to a rule produced by a generalization, but a rule obtained by induction, i.e. a procedure based on probable (or likely) reasoning and whose conclusion goes beyond what is contained in its premises, this type of induction is called naive induction." In line with this framework, middle school mathematics teachers' approaches in order to teach generalizing number patterns were examined through three strategies; algebraic generalization, arithmetic generalization and naive induction.

METHODS

Qualitative research method was employed for this research. Interviews were the main technique. Primary mathematics teachers participated face to face interviews. Interviews were designed to explore teachers' subject matter knowledge about number pattern generalization and pedagogical content knowledge of teaching generalization of number patterns. Each interview was conducted at participant teacher's school. All interviews were audio-taped and transcribed.

Participants

Sixteen primary mathematics teachers were agreed to be interviewed. The teachers had diverse backgrounds in terms of their experience as teachers. Their professional experiences were shown in Table 1.

Table 1. Classifying the participants according to experience as teachers

Less Than 15 Years	More Than 15 Years
K ₅ K ₆ K ₇ K ₈ K ₉ K ₁₀ K ₁₃ K ₁₄	K ₁ K ₂ K ₃ K ₄ K ₁₁ K ₁₂ K ₁₅ K ₁₆

Data Analyses

Data analyses consisted of coding the interview transcripts. Teachers' views were identified and categories were proposed. The categories for number pattern generalization included teaching approaches, knowledge of students' misconceptions, the importance given to number patterns, knowledge of teaching and subject matter knowledge. In the next section findings about teachers' views and teaching approaches will be discussed around the consisted categories.

RESULTS AND FINDINGS

Mathematics teachers' views are presented in terms of three categories: (i) teaching approaches (ii) knowledge of teaching (iii) subject matter knowledge. The categories and sub-categories are shown in table 2.

Table 2. The Views About Number Patterns and Teaching Generalization of Number Patterns

Categories and Sub-categories		Participants	f
Teaching Approaches	Teaching with Different Strategies	K ₁ K ₂ K ₃ K ₄ K ₅ K ₆ K ₈ K ₁₀ K ₁₁ K ₁₂ K ₁₃ K ₁₄ K ₁₅ K ₁₆	14
	Teaching with Examples	K ₂ K ₃ K ₅ K ₆ K ₇ K ₈ K ₉ K ₁₁ K ₁₅	9
	Teaching with Multiple Representations	K ₁ K ₂ K ₃ K ₄ K ₆ K ₈ K ₉ K ₁₂ K ₁₃ K ₁₄	10
	Giving the Rule	K ₁ K ₉	2
	Knowledge of Teaching	Effective Use of Multiple Representations	K ₁₃
	Ineffective Use of Multiple Representations	K ₂ K ₃ K ₄ K ₆ K ₈ K ₉ K ₁₂ K ₁₄	8
Subject Matter Knowledge	Sufficient	K ₆ K ₁₀ K ₁₃	3
	Insufficient	K ₃ K ₅ K ₁₃ K ₁₆	4

Teachers have a variety of views about how instruction should take place and how generalization of a number pattern should be taught. These opinions are examined in detail below.

Teaching Approaches

As seen in table 2, participants' teaching approaches gathered around four sub-categories: (i) teaching with different strategies, (ii) teaching with examples (iii) teaching with multiple representations (iv) giving the rule. Teachers rarely preferred to give the rule in teaching process, rather they mostly preferred to teach with strategies and representations. They also tend to teach with examples in which also naive induction strategy is utilized.

As stated before, middle school mathematics teachers' approaches in order to teach generalizing number patterns were examined through three strategies in line with the theoretical framework; algebraic generalization, arithmetic generalization and naive induction. It was seen that teachers frequently used arithmetic generalization and naive induction rather than algebraic generalization. Only one of the participants (K_{13}) used algebraic generalization as a strategy. Most of the participants (for example K_5) claimed that naive induction could be the only way to generalize a number pattern:

"... students' computation ability must be very fast and practical to generalize a number pattern. He or she must examine the numbers and understand the relationship between numbers immediately by practicing a lot".

Some teachers (for example K_8) claimed that students need to examine the relationship between consecutive numbers in a pattern with trial and error strategy. This approach leads to use arithmetic generalization and naive induction strategies:

"... students must be encouraged to investigate the relationship between consecutive numbers. I tell my students to add or multiply or subtract or divide numbers to find the number in the pattern."

Most of the teachers stated that it is useful to use multiple representations in teaching process. They usually used table and pictorial representations of the number patterns.

In brief, teachers' one of the approaches for teaching generalization of number patterns were arithmetic and this kind of generalization was not of an algebraic in nature (Radford, 2008). The other approach is naive induction, in which abductions were mere guesses. In other words abductions did not lead to a rule by a generalization, but a rule obtained by induction (Radford, 2008).

Knowledge of Teaching

The use of multiple representations was the main strategy pointed both in primary mathematics curriculum and textbooks. Therefore teachers' knowledge of teaching was determined in terms of the use multiple representations. Teachers were expected to use any representation in the way of supporting students' algebraic thinking. See the pictorial representation shown in figure 2.

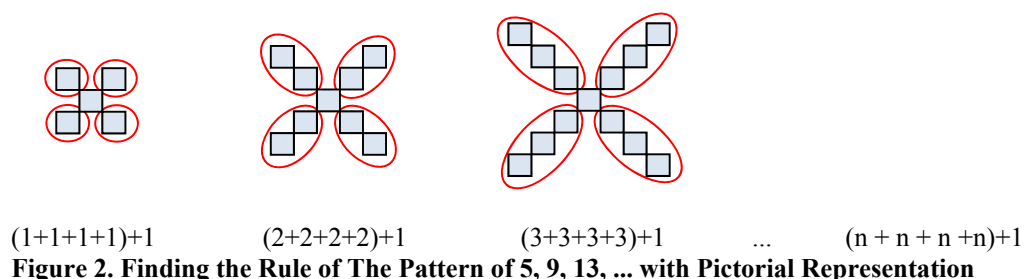

We could find the rule considering the representation and Radford's framework. Here a commonality C was inferred from a few particular cases. Then, this commonality was generalized to the rest of the terms of the sequence. Next, the abduction C became an hypothesis and then the rule $(n+n+n+n)+1$ was calculated.

It was found that seven of sixteen teachers did not use either table or pictorial representations. It was also seen that teachers who used pictorial representations in their lessons did not aware of the potential of the

representations. They usually preferred to use them just for counting and determining the number pattern or visualization. One of the teachers (K₉) said:

"...students complete the pattern and have fun. So the lesson becomes more visual and joyful."

Only one teacher (K₁₃) effectively used the pictorial representation at all:

"Students could easily transfer from pictorial representations to algebraic rule. I encourage students to examine pictorial representation and find a common point. According to me it is important to use pictorial representations which helps students to see the relationship between models and transfer this relationship into algebraic rule."

Subject Matter Knowledge

Although we did not ask any question regarding generalizing a number pattern directly, we could decide some teachers' (seven of sixteen) subject matter knowledge from their words during interviews. Four of seven teachers were insufficient subject matter knowledge. One of the misconception teachers have is the idea of there is only one way to represent a number pattern algebraically. Apparently we could also find another rule shown in figure 3.

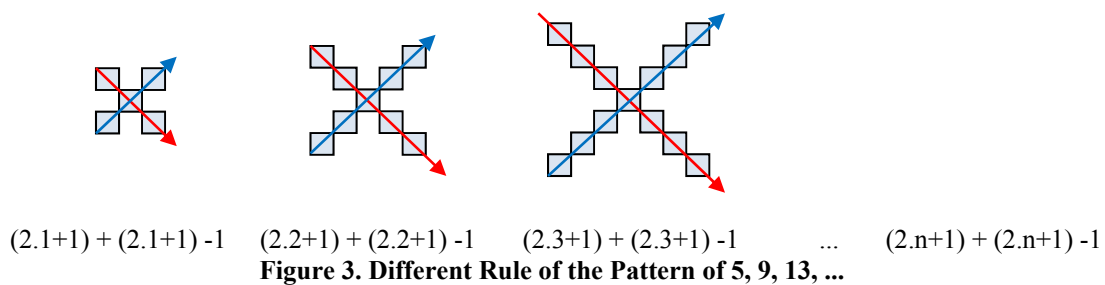

Although both expressions are algebraically equal, emphasizing the variety of rules helps students to develop algebraic thinking. Teachers also stated that the only strategy to find the algebraic rule of a number pattern is 'just keep trying' which leads either arithmetic generalization or naive induction.

CONCLUSION

As was described before, this study reports on middle school mathematics teachers' views about teaching generalization of number patterns. We concluded that teachers rarely preferred to give the rule in teaching process, rather they mostly preferred to teach with strategies, examples and representations. However they did not use pattern-specific strategies and encouraged students to make arithmetic generalization or naive induction. This approach may emanate from their lack of subject matter knowledge because it was also seen that they also use these strategies when it comes to find the rule of a pattern by themselves. Seven of the teachers who participated in the study used pictorial representations in their lessons did not aware of the potential of the representations. They usually preferred to use them just for counting and determining the number pattern or visualization.

RECOMMENDATIONS

In our study we found that teachers appeared to teach with notions, however algebraic pattern generalizations are not characterized by the use of notations (Radford, 2008, p.93). Because of lack of subject matter knowledge, teachers usually employ trial-and-error and finite differences as strategies which were also common misconceptions of students reported in literature (Rossi, Becker & Rivera, 2006). In terms of teaching generalization of number patterns, teachers need to deepen their understanding and appreciations of the use of representations.

Acknowledgement

This study is part of a project (project number 2013.KB.EGT.003) funded by Dokuz Eylul University Scientific Research Projects Commission.

REFERENCES

- Berg, C. V. (2009). *Developing algebraic thinking in a community of inquiry: Collaboration between three teachers and a didactician*. Doctoral dissertation at the University of Agder. Kristiansand, Norway: University of Agder.
- Radford, L. (2006). Algebraic thinking and the generalization of patterns: a semiotic perspective. In J. L. C. S. Alatorre, M. Sa'iz, Me'ndez (Eds.), *Proceedings of the 28th Conference of the International Group for the Psychology of Mathematics Education, North American Chapter* (Vol. 1, pp. 2–21). Mexico: Me'rida.
- Radford, L. (2008). Iconicity and contraction: A semiotic investigation of forms of algebraic generalizations of patterns in different contexts. *ZDM Mathematics Education*, 40, 83–96.
- Rossi Becker, J., & Rivera, F. (2006). Sixth Graders' Figural and Numerical Strategies for Generalizing Patterns in Algebra. In S. Alatorre, J. L. Cortina, M. Sa'iz, & A. Me'ndez (Eds.), *Proceedings of the 28th annual meeting of the North American chapter of the international group for the psychology of mathematics education* (Vol. 2, pp. 95–101). Me'rida: Universidad Pedagógica Nacional.
- Yesildere-Imre, S. & Akkoc, H. (2012). Investigating the development of prospective mathematics teachers' pedagogical content knowledge of generalising number patterns through school practicum, *Journal of Mathematics Teacher Education*, 15: 207-226.
- Zazkis, R., & Liljedahl, P. (2002). Generalization of patterns: The tension between algebraic thinking and algebraic notation. *Educational Studies in Mathematics*, 49(3), 379–402.

OTOMOTİV SEKTÖRÜNDE YENİ TEKNOLOJİLER İÇİN ÇOK BOYUTLU EĞİTİM-ÖĞRETİM PLATFORMU

MULTIDIMENSIONAL EDUCATION AND TRAINING PLATFORM FOR NEW TECHNOLOGIES IN AUTOMOTIVE INDUSTRY

Yavuz SOYDAN

Sakarya Üniversitesi Mühendislik Fakültesi Makine Mühendisliği Bölümü, Esentepe, Sakarya, Türkiye
soydan@sakarya.edu.tr

Per-Henrik PERSSON

Infocar Training AB, Arsta, Sweden

Lucian GRIGORE

The University of South-East Europe, Romania

M. Sait SOYDAN

Tagem Kopisan Ltd., Sakarya, Türkiye

ÖZET: Batarya Elektrikli Taşıt (BET) teknolojileri, günümüzde en hızlı gelişen alanlardan birisidir. İnovatif, ekolojik, teknolojik, ekonomik ve sosyal katma değeri yüksek olan BET alanında; yüksek verimli, sürdürülebilir, bilgi ve iletişim teknolojilerini aktif olarak kullanan bir eğitim programı/platformu oluşturulması gerekmektedir. AB destekli VEMEV projesi kapsamında, ilköğretimden doktora seviyesine kadar, örgün, yaygın, e-öğrenme ve mobil-öğrenme araçlarını kullanacak eğitim-öğretim platformu oluşturularak, pilot uygulamaları gerçekleştirilmektedir. BET alanı, makine, elektrik, elektronik, bilgisayar mühendislerinin, fizikçilerin, kimyacıların, endüstrinin ve yatırımcıların birlikte çalışmalarını gerektirir. BET teknolojisindeki hızlı gelişme eğitim-öğretim alanında da paydaşların altyapı, uygulama ve deneyim paylaşımını zorunlu kılmaktadır.

Bu makalede çok disiplinli BET alanında “entegre/bütünleşik” bir eğitim-öğretim programı ortaya çıkarmak için temel bilgilerinin anlaşılmasından, uygulanmasına, daha ileri düzeyde araştırılmasına ve geliştirilmesine yönelik modüler bir program önerilmiştir. Çalışmada, BET alanında farklı aktif öğrenme teknikleri ve öğretim stratejileri incelenmiş, karşılaştırılmış, tartışılmış, bütünleştirilmiş, sürekli iyileştirilmeye, güncellenmeye ve geliştirilmeye açık aktif bir eğitim-öğretim program mimarisi sistematik olarak sunulmuştur.

Anahtar sözcükler: Batarya Elektrikli Taşıt, Mesleki Eğitim ve Öğretim Programı, Otomotiv Endüstrisi

ABSTRACT: Battery Electric Vehicle (BEV) technologies field is one of the fields that is rapidly developing in today's world. In the field of BET having high innovative, ecological, technological, economic and social added value; an education program/platform that actively uses the highly efficient, sustainable information and communication technologies must be developed. Within the scope of EU supported VEMEV project, an education platform that uses the formal, non-formal, e-learning and mobile learning tools are being formed from the primary school to the doctorate level and the pilot implementations are being realized. The field of BET requires the cooperation of machine, electric, electronic, computer engineers, physicians, chemists, industry and the investors. The rapid development in BET technology entails the substructure, implementation and experience sharing of the stakeholders in the education platform.

In this article, a modular program has been recommended from the understanding of the basic information to their implementation, advanced level of research and improvement for the purpose of revealing an education and training program that is "integrated" in the field of BET. In the study, different active learning techniques and educational strategies in the field of BET have been reviewed, compared, discussed, and an active education program architecture open for integration, continuous improvement, update and development has been presented systematically.

Keywords: Battery Electric Vehicle, VET, Automotive Industrie

GİRİŞ

Batarya Elektrikli Taşıtlar

Batarya Elektrikli otomobil benzinli otomobilden çok daha önce üretilmiş ve kullanılmıştır. İlk ticari batarya elektrikli otomobil 1834 yılında Tomas Davenport tarafından geliştirilmiştir (Şekil 1.). 1876 yılında Otto çevriminin bulunması ve Ford Model T'nin ve elektrikli marş motorunun piyasaya çıkması ile içten yanmalı motorlu taşıtlar, elektrikli taşıtların yerini almıştır. Uzun dönem boyunca yoğun çalışma yapılmayan bu teknoloji alanında; yarı iletken teknolojisine dayalı bileşenlerin üretilmesi ve sürekli gelişmesi, yeni enerji depolama teknolojileri, sofistike malzemeler, ileri modelleme ve simülasyon teknikleri, karmaşık kontrol algoritmalarının gerçek zamanlı uygulanması, güç elektroniği ve motor tahriki alanının yeterli olgunluğa ulaşması gibi nedenlerle, 70'li yılların başında daha güçlü bir şekilde yeniden popüler olmuştur. Bu gelişmelerde enerji verimliliği yüksek bir ulaşım aracı geliştirmeye kendini adayan fizik, kimya, matematik, makine, bilgisayar, elektrik ve elektronik uzmanlarının çabaları çok önemlidir. 2010 yılından itibaren Avrupa Birliği ve ABD'deki emisyon standartlarındaki katı kurallar, BMW, Renault, Ford, GM, Toyota gibi global üreticilerin elektrikli taşıt üretimine yeniden başlamalarına neden olmuştur.



Şekil 1. Elektrikli Taşıtlarda İlk Ve Güncel Örnekler.

Batarya Elektrikli Taşıt Mimarisi ve Temel Bileşenleri

Genel olarak elektrikli araçların mimarisi İçten Yanmalı Motorlu (ICE) ve Hibrit (HEV) taşıtlara göre göre oldukça basit ve sadedir. BET temel bileşenleri; Sürüş elektrik motoru, Yüksek voltajlı sürüş bataryası (enerji depolama birimi), Batarya yönetim sistemi, Dahili şarj ünitesi, Kontrol ünitesi, DC/DC ve DC/AC dönüştürücüler, Güç aktarma organları (opsiyonel), Düşük voltajlı yardımcı batarya (genellikle 12V) ve Diğer konvansiyonel taşıt bileşenleri (klima, konfor, multimedya, güvenlik vb.) şeklinde tanımlanabilir.

BATARYA ELEKTRİKLİ TAŞITLAR ALANINDA MESLEKİ EĞİTİM-ÖĞRETİM PROGRAMI

Mevcut eğitim-öğretim programları

Bu çalışmada taşıtın ihtiyaç duyduğu enerjinin tamamının taşıt üzerindeki bir enerji depolama biriminden (bataryadan) karşılandığı "Batarya Elektrikli Taşıt (BET)" eğitim ve öğretim programları incelenmektedir. BET'ler sağlık, ekoloji, ekonomi ve enerji güvenliği açısından oldukça verimli çözümler sunmaktadır. Bu taşıtların gelecekte önemli bir rol oynayacağına şüphe yoktur ve özellikle ekonomik ve endüstriyel sektörlerde büyümeye devam etmesi beklenmektedir. Batarya Elektrikli Taşıtların sahip olduğu öneme rağmen dünya genelinde, elektrikli araçların, şarj altyapısının tasarım, üretim, bakım ve onarımında rol alan tüm alanları tek bir öğretim programında sentezlemeye çalışan, çok az sayıda eğitim ve öğretim programı bulunmaktadır. Günümüzde özellikle ABD'de BET alanında geliştirilmiş ve uygulanan farklı eğitim-öğretim programları bulunmaktadır. Bu programların büyük çoğunluğu lisans ve yüksek lisans programları şeklindedir. 2010 yılına kadar çok sayıda disiplini barındıran elektrikli taşıt alanı, elektrik makineleri, güç elektroniği, enerji, kimya mühendisliği ve mekanik tasarım alanında alınan eğitim ve öğretim programlarının izole edilmiş bir uygulaması olarak değerlendirilmiştir. Bu bakış açısının sonucunda yüksek verimli BET geliştirme potansiyeli ve daha uygun maliyetli çözümler eksik kalmıştır. Bu olumsuz sonuçta eğitim ve öğretim programlarındaki noksanlıktan kaynaklanan deneyim ve uzmanlık yetersizliği büyük rol oynamaktadır. Bu çalışma BET'lere yönelik bütünlük eğitim-öğretim programları konusundaki güncel çalışmaları ve VEMEV projesi kapsamında geliştirilen yeni önerileri kapsamaktadır.

VEMEV Eğitim-Öğretim Programı

Program hazırlama her eğitim-öğretim kurumun temel unsurlarından birisidir ve oldukça kapsamlı bir çalışmadır. VEMEV projesi kapsamında, BET'lere yönelik bütünleşik bir eğitim-öğretim programı ortaya çıkarmak için farklı aktif öğrenme teknikleri ve öğretim stratejileri incelenmiş, karşılaştırılmış, tartışılmış, bütünleştirilmiş, sürekli iyileştirilmeye ve geliştirilmeye açık bir program mimarisi oluşturulmuştur.

Mesleki eğitim-öğretim programlarının düzenli aralıklarla gözden geçirilmesi, güncellenmesi gereken aktif yapısı; küreselleşme, finansman imkanları, bilgi teknolojisi ve kaynak sınırlamasındaki gelişmelerden zamana bağlı olarak etkilendiği unutulmamalıdır. Yüksek verimli, değişikliklere adapte olabilen ve sürdürülebilir bir program mimarisinin oluşturulması oldukça önemlidir.

Programda sorgulamaya dayanan öğrenmeyi temel alan öğretme modeli ve aktif öğrenme teknikleri önerilmektedir. Sorgulama süreci araştırmak, keşfetmek ve sonuç olarak daha üst seviyede bilgiye ulaşmayla ilgilidir. Program aşağıdaki temel adımlar izlenerek oluşturulmuştur:

- Batarya Elektrikli Taşıtlarla ilgili “genel bilgi ve deneyim” alanlarının tanımlanması,
- Ulusal (MYK), Avrupa Birliği ve Uluslararası mesleki standart ve yeterlilik tanımlamaları dikkate alınarak program seviyelerinin tanımlanması,
- Her bir seviye için meslek tanımının yapılması,
- Seviyelere başlama ve seviyeler arasındaki geçişlerin “modüler” olarak tanımlanması,
- Batarya Elektrikli Taşıtlarla ilgili seviyelere uygun meslek standartlarının oluşturulması,
- BET'lerle ilgili meslek standartları esas alınarak mesleki yeterliliklerin oluşturulması ve
- Ayrıca her bir seviyenin; hedefleri, ön şartları, gereklilikleri, beklenen sonuçları ve genel önerileri verilmektedir.

Genel Alan Bilgisi

Günümüzde, batarya elektrikli bir taşıtın tasarım ve üretimi makine, elektrik, elektronik, bilgisayar mühendislerinin, fizikçilerin, kimyacıların, endüstrinin ve yatırımcıların birlikte çalışmalarını gerektirir. Klasik otomotiv teknolojisindeki mekatronik uygulamaları dikkate aldığımızda, elektrikli taşıtlar için bu tanımlamayı sürüş bataryasının öneminden dolayı kimekatronik (chemimechatronic) bir sistem olarak tanımlanabilir. Batarya elektrikli taşıtlar konusunda hazırlanacak eğitim ve öğretim programlarında, öğrencilerin aşağıdaki alanları (Tablo 1.) içeren, uygulamalarda kullanabilecekleri bilgi ve deneyimlere sahip olmaları hedeflenmelidir:

Tablo 1. BET genel bilgi ve beceri alanları.

BET GENEL BİLGİ VE BECERİ ALANLARI							
Matematik Fizik	Kimya	Makine	Elektrik	Elektronik	Enerji yönetimi	Bilgisayar	İş ve Güvenlik
	Batarya PV Süper kapasitör	Sistem mimarisi Elektrik makinaları Güç aktarma org. Termal yönetim	Enerji dönüşümü Motor modelleme Devre tasarımı Elektrik Makinaları	Güç elektronikliği Sürücüler	Şarj, Dönüşüm, İletim	Bilgisayar destekli; Modelleme, Simülasyon, Bakım, Tasarım, İmalat ve BET için gömülü sistemler	Güvenlik Enerji ekonomisi ve politikası Geri dönüşüm yönetimi, çevre Girişimcilik
	Ölçüm, Test, Arıza Teşhisi, Değerlendirme						
	Bakım ve Bakım Yönetimi						

Program Seviyeleri

Kişiler, ilk eğitim-öğretim döneminde okuma yazma, temel hayat bilgi, beceri ve yeterliliklerini kazandıktan sonra bilgi veya beceri ağırlıklı alanlara yönelirler. Bilgi ağırlıklı yönelimler öğretim, beceri ağırlıklı yönelimler eğitim kapsamında değerlendirilebilir. Bu iki alan arasında kesin çizgiler oluşturmak ve tanımlamak mümkün değildir. Fakat tasarlanan ve uygulanan programlar zaman içerisinde eğitim/beceri veya öğretim/bilgi formasyonlarının gelişimini belirler. Verimli bir kariyer gelişimi için ilk eğitim-öğretim tamamlandığında yönelimlerin ana hatları ile belirlenmiş olması gerekir. Burada kişi alan seçimi yaparak pratik beceri ağırlıklı mesleki eğitime veya teorik bilgi ağırlıklı öğretim hayatına devam eder. Bu temel seviyeler (Şekil 2) arasında her zaman geçiş mümkündür. Günümüzdeki ekonomik, teknolojik, sosyal ve kültürel gelişmeler, bu alanda

insan hakları açısından önemli olanaklar sunmaktadır. Mesleki kariyer basamaklarında önemli bir alanda seviyeler arasındaki iletişimidir. Pratik beceri ağırlıklı eğitim almış bir teknisyen ile bilgi ağırlıklı öğretim almış bir mühendis arasında mesleki iletişim problemleri yaşanmaktadır. Birçok ülkede bu iletişim problemlerinin çözümüne yönelik olarak meslek yüksek okulları gibi ara eleman seviyeleri oluşturulmuştur.

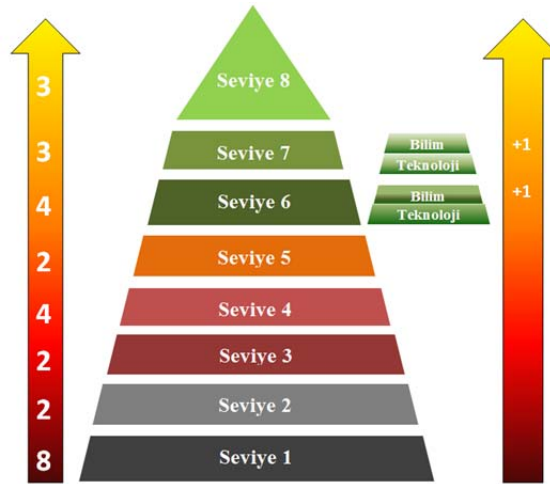

Şekil 2. Mesleki eğitim-öğretimde seviyeler, önerilen süreler ve alt tanımlamalar.

Öğrencilere ilk dönemlerde daha ileri düzeydeki derslerde kullanacakları temel bilgiler verilmektedir. Bu dönemde verilen derslerin alınması ve yeterliliklerin sağlanması zorunludur. Eğitim programının iyi bir şekilde uygulanması için ilgili alanının izole edilmiş gerekli bilgilerinin, zorunlu ders verilerek denemesi gerekmektedir. Bu akademisyenin ve eğitimcinin gelişmesi açısından da önemlidir.

Zorunlu dersin ana fikri;

- Mesleğin öğrenilmesi, uygulanması ve geliştirilmesi için gerekli temel bilgi ve becerilerin verilmesi,
- Güncel bilimsel ve teknolojik bilgi ve becerilerin verilmesi,
- Ulusal, bölgesel ve uluslararası mesleki tanınırlığın sağlanması ve

İzleyen dönemlerde zorunlu derslerle birlikte seçmeli derslerde sunulmaktadır. Öğrencinin istediği seçmeli dersi alabilmesi için bu ders için hazırlanmış e-öğrenme içeriklerinden hazırlık aşamasında başarılı olma zorunluluğu önerilmektedir.

Seçmeli dersin ana fikri;

- Öğrencinin BET ile ilgili özel alanlarda, daha detaylı bilgi ve deneyim ihtiyacının karşılanması,
- Özel alanlardaki güncel bilimsel ve teknolojik eğilimlere yönelik, meslek seviyesine uygun yeterliliklerin sağlanmasıdır.

Mesleki eğitim-öğretim programlarının son dönemlerinde genellikle mesleki gelişim için ders ve uygulamalar (laboratuvar, atölye vb.) yer almaktadır. Burada temel hedef öğrencinin katılacağı endüstriyel uygulama programlarındaki anlama, öğrenme, kavrama, uygulama kısacası başarı düzeyini artırmaktır. Mezuniyetten önceki dönem endüstriyel uygulama programları ağırlıklıdır. Bu ortak çalışma deneyimi öğrencilere, uzmanlaşma tercihini daha iyi yapabilmeleri için gerçek yaşam deneyimi kazandıracaktır. Ayrıca öğrencilerden gelen en son teknolojik gelişmeler hakkındaki geri beslemeler, akademik çevrelerde piyasa ihtiyaçlarının daha iyi anlaşılmasını sağlayacaktır.

Yeterlilik Kod Anahtarı

Mesleki seviye, ölçek değeri, yeterlilik kod anahtarı ve BET alanı ile ilgili örnek tanımlamalar Tablo 2'de verilmiştir. Bu tablo alan bilgisi, becerisi ve yeterliliklerle ilgili tanımlamalarda program yapımcılara büyük kolaylıklar sağlamaktadır. Bu tablonun hazırlanmasında Yenilenmiş Bloom Taksonomisi'nden ve Avrupa Mesleki Yeterlilikler Çerçevesi dokümanlarından faydalanılmıştır.

Tablo 2. Yeterlilik Kod Anahtarı

İŞ/GÖREV SEVİYELERİ	ÖLÇEK DEĞERİ	YETERLİLİK KOD ANAHTARI	YETERLİLİK ÖRNEKLERİ
YETKİNLİK	1	Çalışan işi doğrudan gözetim altında belirli kurallarla tanımlanmış şekilde yapabilir. İşin basit bölümlerini yapabilir. İşin büyük bir bölümünü nasıl yapılacağını söylemesi veya gösterilmesi gerekir. (Son derece kısıtlıdır)	Meslek öncesi yeterlilikler (İlköğretim Dipl.).
	2	Çalışan işi gözetim altında sınırlı özerklik ile yapabilir. İşin büyük bölümünü yapabilir. Sadece zor bölümlerde yardıma ihtiyacı vardır.	Temel mesleki yeterlilikler (Yaygın eğitim sertifikası).
	3	Çalışan görevlerin tamamlanmasıyla ilgili sorumluluk alır ve problemlerin çözümünde kendi davranışlarını ortama uyarlar. İşin bütün bölümlerini yapabilir. Sadece bitmiş işin kontrolü gerekir.	Yarı-yetkin ara eleman yeterlilik. (Yaygın eğitim sert.).
	4	Çalışan çoğunlukla öngörülebilir, ancak değişime tabi olan bir işi yaparken öz-irade kullanır. İş faaliyetlerinin değerlendirilmesi ve geliştirilmesi için bir miktar sorumluluk alarak diğerlerinin (alt seviyedekilerinin) rutin işlerini denetler. Bütün işi doğru bir şekilde yapabilir. Başkalarına işi nasıl yapacaklarını söyleyebilir veya gösterebilir.	Tam yetkinliği olan ara eleman yeterlilikleri (Yaygın eğitim sert., Meslek Lisesi Dipl.).
	5	Çalışan öngörülemeden değişimin bulunduğu iş faaliyetlerini yönetir ve denetler. Kendisinin ve diğerlerinin performansını değerlendirir ve geliştirir.	Ön-Lisans. İleri mesleki yeterlilikler.
	6	Çalışan karmaşık teknik veya profesyonel faaliyet veya projeleri yönetir. Öngörülemeden iş faaliyetlerinde karar verme sorumluluğu alır. Bireylerin ve grupların profesyonel gelişimlerini yönetmede sorumluluk alır.	Lisans Derecesi. Profesyonel ve yönetici mesleki yeterlilikleri.
	7	Çalışan öngörülemeden, karmaşık ve yeni stratejik yaklaşımlar gerektiren iş faaliyetlerini yönetir ve değiştirir. Çalışma gruplarının profesyonel bilgi ve uygulamalarına katkıda bulunmada ve/veya stratejik performanslarını değerlendirmede sorumluluk alır.	Yüksek Lisans Derecesi. Uzman profesyonel yeterlilikler. Üst düzey yönetici yet.
	8	Çalışan yüksek düzeyde yetki, yenilik, özerklik, akademik ve profesyonel bütünlük sergiler. Araştırma ve yeni fikir ve süreçlerin gelişiminde sürekli bir sorumluluk (bağımlık) taşır.	Doktora Derecesi.
BİLGİ	a	Çalışan, temel genel bilgiye sahiptir. Parçaların ve aletlerin isimlerini bilir ve işin temel bilgilerine sahiptir.	OLGUSAL Terminoloji
	b	Çalışan, bir alanda temel pratik bilgiye sahiptir. İş yapmak için gereken prosedürleri adım adım bilir.	OLGUSAL Pratik terminoloji
	c	Çalışan, bir alanda olgulara, ilkelere, süreçlere ve genel kavramlara dair bilgiye sahiptir. İşin neden ve ne zaman yapılması gerektiğini ve her adıma neden ihtiyaç duyulduğunu bilir.	KAVRAMSAL Kavrama
	d	Çalışan, bir alan içerisinde geniş kapsamlı, pratik ve teorik bilgiye sahiptir. İşle ilgili sorunları tahmin edebilir, ayrıştırabilir ve çözebilir.	KAVRAMSAL Bilgiyi kullanma
	e	Çalışan, bir alanda kapsamlı, uzmanlaşma gerektiren, pratik ve teorik bilgiye ve bilgi temelinin sınırlarıyla ilgili farkındalığa sahiptir.	İŞLEMSEL Çalışma prensipleri
	f	Çalışan, bir alandaki teori ve ilkeleri eleştirel bir yaklaşımla anlamayı içeren ileri düzey bilgiye sahiptir.	İŞLEMSEL Analiz, Sentez
	g	Çalışan, özgün düşünmeye ve/veya araştırma yapmaya temel teşkil eden ve bir kısmı belli bir alanda öne çıkan yüksek derecede uzmanlaşmış bilgiye sahiptir. Bir alanla ilgili bilgiler ve farklı alanlar arasındaki etkileşim hakkında ciddi farkındalığa sahiptir.	ÜSTBİLİŞSEL Yorumlama, değerlendirme
	h	Çalışan, bir alan ve alanlar arasındaki etkileşim hakkında en üst düzeyde öne çıkan bilgiye sahiptir.	ÜSTBİLİŞSEL Değerlendirme, Geliştirme
BECERİ	A	Çalışan, basit görevleri yerine getirmek için gereken temel becerilere sahiptir. Konu hakkında temel bilgileri ve terimleri bilir	Hatırlama
	B	Çalışan, basit kuralları ve aletleri kullanarak görevleri yerine getirmek ve rutin problemleri çözmek için ilgili bilgileri kullanmada gereken temel bilişsel ve pratik becerilere sahiptir. Temel bilgiler arasındaki ilişkileri kurabilir ve konu hakkında genel prensipleri bilir.	Anlama
	C	Çalışan, temel yöntemleri, araçları, malzeme ve bilgileri seçerek ve uygulayarak problemleri çözmek ve görevleri tamamlamak için gereken bir dizi bilişsel ve pratik becerilere sahiptir. Bilgileri ve prensipleri analiz ederek konu hakkında sonuca ulaşabilir.	Uygulama
	D	Çalışan, bir alanda belirli problemlere çözüm üretmek için gerekli olan bir dizi bilişsel ve pratik becerilere sahiptir. Şartları değerlendirip konu hakkında doğru karar verebilir.	Uygulama Analiz
	E	Çalışan, soyut sorunlara yaratıcı çözümler geliştirmek için gereken kapsamlı bir dizi bilişsel ve pratik becerilere sahiptir.	Sentez Değerlendirme
	F	Çalışan, uzmanlık gerektiren bir alanda karmaşık ve öngörülemeden sorunları çözmek için gereken ustahğı (hakimiyeti) ve yeniliği ortaya koyan ileri düzey becerilere sahiptir.	Sentez Değerlendirme
	G	Çalışan, yeni bilgi ve yöntemler geliştirmek ve farklı alanlardaki bilgileri birleştirmek amacıyla yürütülen araştırma ve/veya yenilik faaliyetleri için gereken uzmanlaşmış sorun çözme becerilerine sahiptir.	Sentez İnovasyon
	H	Çalışan, araştırma ve/veya yenilik yaparken önemli sorunları çözmek ve mevcut bilgi veya profesyonel uygulamayı genişletmek ve yeniden tanımlamak için gereken, sentez ve değerlendirme dahil, en gelişmiş ve uzmanlaşmış beceriye ve tekniğe sahiptir.	Yeniden oluşturma

Meslek seçimi, insanoğlu için önemli bir aşamadır. Bu seçimde kişisel, ailevi, coğrafi, bölgesel, konjonktürel ve toplumsal etkiler farklı şekillerde ve seviyelerde rol oynamaktadır. Özellikle az gelişmiş ve gelişmekte olan ülkelerde meslek seçimi bilgi, ilgi ve kapasite ölçümüne dayanmamaktadır. Bu ülkelerde seçim daha çok ailevi baskılar, toplumsal yönelimler, gelir durumu dikkate alınarak yapılmaktadır. Dolayısı ile insanların büyük çoğunluğu belirli bir dönem sonra meslek değiştirme, mesleki alanda eğitim seviyesini artırma gibi talepler oluşmaktadır. Bu son durum dikkate alınarak mesleki seviyeler arasında geçişleri mümkün kılacak modüler bir eğitim-öğretim modeli çok daha kullanışlı olacaktır. BET alanında “entegre/bütünleşik” bir eğitim programı ortaya çıkarmak için temel BET bilgilerinin anlaşılmasından, uygulanmasına, daha ileri düzeydeki uygulamaların geliştirilmesine ve araştırılmasına yönelik modüler bir eğitim programı önerilmiştir. Programın temel özelliği istenilen yetkinlik ya da modül ile bu yetkinliği yerine getirmek için tasarlanan eğitim programı arasında, performans ölçümü ile ilk aşamalardan itibaren doğal bir ilişki kurulmasıdır. Bu ilişki için gerekli metodoloji; modülün tanımlanması, modül düzeni, modülün yapılandırılması, her bir modülün revizyonu, her bir modül için öğretim programının ve içerik yapısının revizyonu ile sağlanır. Her seviyenin yanında çapraz bir modül olduğu görülebilir. Bu modüller seçmeli olacak şekilde sunulur ve bir seviyeden diğerine geçebilmek için tamamlanması gerekir. Bu esneklik bazı öğrencilerin nasıl olduğu bilgisi (know-how) ile başlaması ve ardından neden olduğu bilgisi (know-why) ile ilgilenmeleri önermesine dayanmaktadır.

Eğitim ve Öğretimde Güncel Teknoloji Kullanımı

BET alanında hazırlanan programın öğrenciler tarafından benimsenmesi için yeni öneriler, aktiviteler ve güncel teknolojilerin kullanımı önemlidir. Hızla gelişen bir teknoloji alanı olarak BET sektöründeki yeni kariyer fırsatlarını sunmak için yoğun multimedya kullanımı, son teknoloji laboratuvar tesisleri, araştırma laboratuvarları ve çevre sorunlarına vurgu yapan açık hava etkinlikleri değerlendirilmelidir. Bu faaliyetler, alanın geliştirilmesi ve büyütülmesinde temel adımlardır. Günümüzde öğrenci ile öğretmen arasındaki klasik ilişki minimuma düşmüştür ve öğrenme aktivitesi hemen hemen anonim hale gelmiştir. Bu kısıtlamalar akademide ve endüstride araştırma ve geliştirme alanında yeni bir paradigma açmıştır. Okulda artık yalnızca tahta ve tebeşire dayalı bir etkileşim geçerli değildir. Bu senaryoya göre önerilen öğretim programında yeni öğretme tekniklerinin uygulanması tavsiye edilir. Öğrenciler yaparak, üretirken, yazarak, tasarlayarak, yaratarak ve çözerek öğrenirler. Dolayısıyla, bu öğretim programının başarılı bir şekilde uygulanması için öğrencinin yeni bilgileri öğrenme motivasyon ve merakına katkıda bulunacak aktif öğrenme tekniklerinin kullanılması önerilir. Aktif öğrenme tekniklerinin, bu program kapsamında yaygın bir şekilde uygulanması hedeflenmiştir. Bilgi ve Teknoloji (BT) çağının sınıflara ulaştığına şüphe yoktur ve öğrenciler yakın zaman öncesine göre daha aktif ve görsel iletişime alışmış durumdadır. Günümüzde Facebook, Twitter, Bloglar, anlık mesajlaşma programları öğrencilerimizin bilgiyi paylaşmak için kullandığı çok sayıdaki araçtan yalnızca birkaçıdır. Öğrencilerimiz, günlük yaşama yönelik birçok uygulamadan dolayı, bilgisayar veya akıllı telefon kullanımını ve mobil uygulamaları iyi bilmektedir. Öğrenciler, öğretmenlerden de bu araçları bilmelerini ve bu teknolojilerin eğitim-öğretim programlarına girmesini beklemektedirler. Dolayısıyla bir programın daha iyi uygulanması için bu yeni araçların program tasarımına dahil edilmesi gerekmektedir. Güncel teknolojilerin yerinde ve yeterli ölçüde kullanımı doğal olarak öğrencinin derse ilgisini artıracaktır. Örnek olarak öğretmen tarafından yönetilen bir ders için öğrencilerin son dakika duyurularını kontrol edebilecekleri bir twitter hesabı açılabilir. Günümüzde tüm eğitim-öğretim kurumlarının en önemli problemlerinden birisi de akademisyen başına düşen öğrenci sayısının artmasıdır. Bunun bir sonucu olarak gelişmiş ülkelerdeki üniversitelerde büyük salon ve anfilerin kullanılması genel bir uygulamadır. Bu anfilerin güncel teknoloji ile donatılması, multimedya donanım ve yazılımlarının sürekli güncellenmesi, klima, aydınlatma sistemlerinin alan ve öğrenci kitlesi ile uyumunun sağlanması, oturma düzenleri, interaktif etkileşim olanakları, giriş ve çıkışların düzenlenmesi verimi artıracak unsurlardır. Aktif öğrenme tekniklerinin dahil edildiği anlatım ve sınıf ortamına ek olarak iyi organize edilmiş bir konu akışı ve kullanışlı bir web sayfasının hazırlanması da gerekir. Öğrencilere tek bir yerde tüm gerekli bilgileri veren bu faaliyetler, öğrencilerin ilgisini arttıracaktır. Ayrıca öğretmenin dersle ilgili yeni materyal temin etme süresinin azaltılmasına yardımcı olacaktır. Öğretmenin etkin çevrimiçi öğrenme siteleri oluşturmak için kullanabilecekleri Blackboard, Avenue, Moodle vb. yazılım uygulamaları bulunmaktadır. Eğitim-öğretim kurumları bu yazılımları öğretmenler için ücretsiz olarak temin etmelidir. Bu yazılımlar; Ders Yönetim Sistemi (CMS), Öğrenme Yönetim Sistemi (LMS) veya Sanal Öğrenme Ortamı (VLE) olarak bilinir. Özet olarak iyi tasarlanmış, gelişime açık bir mimariye sahip eğitim-öğretim web sayfaları:

- Öğrencilerin öğretmen ile daha etkin bir iletişim kurmalarını sağlama,
- Öğrencileri bilgilendirme,
- İlgilerini uyanık tutma ve
- Derste işbirliğini sürdürme gibi fonksiyonları yerine getirebilir.

Web sayfasında dersi veren akademisyen veya öğretmen ilgili bilgileri; özgeçmiş, uzmanlık alanları, aldığı ödüller, yayınlarına yapılan atıflar, aldığı patentler, gerçekleştirdiği teknoloji transferleri, endüstriyel

danışmanlıkları, ilgili haberler ve iletişim vb., bilgileri seçmek için bir menü verilir. Bu menü öğrencilere akademisyen veya öğretmen hakkındaki tüm bilgileri vererek, onun konu ile ilgili uzmanlığı konusunda öğrenciye güven telkin eder. Burada öğretmenin daha önce anlattığı ders videolarından örnekler bulunabilir ve bu videolar güncellenebilir. Diğer menü belirli bir ders ile ilgili, ders ana sayfası, ders programı, okumalar, laboratuvarlar, ödevler, sınavlar, araçlar ve indirilebilir ders materyalleri gibi tüm bilgileri verir. Burada, dersin tanımlanması ve ders özelliklerine ek olarak duyuruların da dersin ana sayfasında yayınlanması teklif edilmiştir. Bu bölüme açık ders materyalleri ve kaynakları ile ilgili bilgiler de dâhil edilebilir. Okuma bölümü dersin sözlü anlatım oturumları hakkında bilgi verir. Burada sözlü sunum slaytları, tamamlayıcı notlar, animasyonlar ve sunulan simülasyonlar yayınlanır. Ayrıca akademisyen veya öğretmenin daha önceki derslerde veya güncel çekilmiş ders anlatım videoları eklenebilir. Diğer menüde; dönem, ders asistanı, laboratuvar personeli, program, ön koşul, ders tanımı, ders amaçları, değerlendirme kriterleri, yazılı görevler ve son teslim tarihleri, akademik ahlak ve notlar hakkında bilgiler verilebilir. Laboratuvar bölümünde, laboratuvar uygulama takvimi, deney föyleri ve laboratuvar kuralları ile güvenlik talimatları hakkında bilgi verilir. Laboratuvarında yapılacak testler ve cihazlarla ilgili ayrıntılı bir görsel arşiv hazırlanması önerilir. Bu laboratuvarlara internet üzerinden de erişimin sağlanması ideal bir alternatif oluşturacaktır. Atölye çalışmalarında görsel anlatımlar, videolar veya simülasyonlar yeterli olmamaktadır. Bunun yerine güncel teknolojiye uygun atölye imkanlarının endüstri ile iş birliği içinde hazırlanması gerekir. Atölye çalışmalarının en fazla 7 kişilik gruplarla ve gözetmen eşliğinde yapılması önerilir. Öğrencilerin atölye ve laboratuvar çalışmalarına girmeden önce internet üzerinden oryantasyon sağlaması gerekmektedir. Özellikle güvenlik konusunda gerekli bilgi ve eğitimleri alarak sınavlarda %100 başarı sağladıktan sonra atölye ve laboratuvar çalışmalarına katılım önerilmektedir. Ödev bölümünde; konular ve program ve sunum formatı hakkında bilgiler verilir. Ayrıca burada bazı çözümlü uygulama problemlerinin bulunması da önerilmiştir. Sınav bölümü, mevcut dönemin sınavlarını yani kısa sınav, vize ve final soru-cevap örneklerini içerir.

Eğitim-Öğretim için İşbirliği

Eğitim-öğretim programının tüm aşamalarında, yeterliliklerin esas alınmasına ve endüstri ile eğitim-öğretim kurumları arasındaki kalıcı, sürdürülebilir bağa vurgu yapılmalıdır. Bu ilişki bağı Şekil 3'te verilen iki kilit alanın ve aktörlerin doğru tanımlanması ile gerçekleştirilebilir. Yüksek verimli, katma değeri yüksek bir eğitim-öğretim programı ve uygulaması için eğitim-öğretim kurumları, bu kurumların çıktılarının uygulama ve çalışma alanını oluşturan endüstri, düzenleyici konumda olan kurumlar, yatırımcılar ve öğrenciler arasında sürdürülebilir bir işbirliği sağlanması gerekmektedir. İşbirliği alan ve modellerinin doğru ve uygulanabilir olması, paydaşların mevcut altyapılarının verimli ve kapasite kullanım oranını artıracak bir şekilde tasarlanması gerekmektedir.



Şekil 3. Eğitim-öğretimde işbirliği

Altyapı: Teknolojideki hızlı değişim sektörler arasında farklılıklar göstermektedir. Bu değişim ve gelişim BET alanında çok daha yüksek bir hızla gerçekleşmektedir. Eğitim-öğretim kurumlarının ve kamu kaynaklarının bu hızla uyum sağlamasını beklemek doğru bir yaklaşım değildir. Bu teknolojik ve ekonomik kısıtların, bizi eğitim-öğretim faaliyetlerini en uygun şekilde gerçekleştirmek için yeni yol ve yöntemler aramaya zorladığı açıktır. Günümüzde her bir bölüm için ayrı bir laboratuvar ve atölye kurulması yüksek maliyetlerden dolayı verimli değildir. Bu programda, endüstri, devlet, eğitim-öğretim ve araştırma kurumları kısacası paydaşlar arasında kaynak ve altyapı paylaşımı planlanmıştır. Bu ortak altyapı oluşturma ve kullanım için işbirliği organizasyonu programın başarılı olması için etkin bir yöntem olarak benimsenmiştir.

Deneyim: Akademisyen ve eğitimci deneyimi, bir eğitim-öğretim programının uygulanmasında temel bir gerekliliktir. Bu deneyim ve uzmanlık; yayınların, kitapların, patentlerin, projelerin, vs. sayısı ile yansıtılmalı ve eğitim programının uygulanmasında yer alan tüm ilgili çevre için özetlenmelidir. Bununla birlikte, çalışmaların teoriden pratiğe dönüşmesi ve katma değer üretmesi gerekmektedir.

SONUÇLAR VE DEĞERLENDİRME

Bu makalede, Batarya Elektrikli Taşıt Bilimi ve Teknolojisi alanında gerçekleştirilmesi planlanan, Seviye 1’den Seviye 8’e kadar bütünlük ve modüler eğitim-öğretim programına genel bir bakış sunulmuştur.

BET alanında hazırlanan bu mesleki eğitim-öğretim platformunda aşağıdaki ana başlıklar ön planda tutulmuştur:

- ✚ Uluslararası alanda geçerliliği olan bir mesleki eğitim-öğretim program mimarisi.
- ✚ Temel alan ve alt alan başlıklarının güncel trendlere uygun ve güncellenebilir olması.
- ✚ BET mesleki eğitim-öğretim alanında etkin, verimli ve sürdürülebilir ulusal ve uluslararası işbirliği.
- ✚ Öğretmen, öğrenci, kurum ve endüstri arasında sürekli açık, interaktif etkileşim kanalları.
- ✚ İlgili tüm alanlarda ve ortamlarda ilgili tüm tarafların güncel teknoloji kullanımı.
- ✚ Uluslararası standartlara uygun güvenilir bir test ve değerlendirme sistemi.

Proje kapsamında yukarıdaki esaslar dikkate alınarak; Çok disiplinli (multi disciplinary) BET alanında, alan bilgisi tanımlamaları uluslararası işbirliği ile yapılmıştır. İsveç’teki başarılı internet destekli uygulamalar transfer edilmiş, yeni uygulamalar geliştirilmiş, alanlarla ilgili basılı ve dijital eğitim-öğretim materyalleri hazırlanmış, uygulamalı eğitimler için örnek atölyeler oluşturulmuş ve pilot eğitimlerle platformun test edilmesine başlanmıştır. Eğitim-öğretim faaliyetlerinde günümüzde gittikçe yaygınlaşan teknoloji odaklı karma yöntem benimsenmiştir.

Çevre ile ilgili davranışların çocukluk gelişiminin erken safhalarında oluşmaya başlamasından dolayı, elektrikli araçlar gibi sürdürülebilir teknolojiler hakkında çocukların bilinçlendirilmesi, eğitilmesi, konunun içine çekilmesi ve aydınlatılması için en uygun ortam ilk ve orta öğretim sınıflarıdır. Bu maksatla Seviye 1’e yönelik olarak ilk ve orta okul öğrencileri ve öğretmenleri için BET okulu çalışmaları da başlatılarak, Sakarya’daki bazı okullarda pilot uygulamalar başlatılmıştır.

Bu çalışma ve yeterlilik tanımlamaları, farklı seviyelerdeki eğitim-öğretim kurumlarına kendi program taslaklarını hazırlamalarında rehber olabilir. Her bölgenin ve kurumun kendi şartları içerisinde programda değişiklikler ve iyileştirmeler yapması beklenen doğal bir süreçtir.

Teşekkür: Bu yayım T.C.Avrupa Birliği Bakanlığı Türk Ulusal Ajansı tarafından desteklenen, “Batarya Elektrikli Taşıtların Bakım/Onarımı Alanında Eğitim/Öğretim İçin Mesleki Eğitim Platformu” - VEMEV - 2012-1-TR1-LEO05-35189”, Leonardo da Vinci Yenilik Transferi Projesi yaygınlaştırma çalışmaları kapsamında hazırlanmıştır. Tüm proje ekibi adına Türk Ulusal Ajansına teşekkür ederiz.

Acknowledgement: This publication has been prepared within the dissemination efforts of Leonardo da Vinci Innovation Transfer Project (Vocational Education Platform for Maintenance of Electric Vehicles: VEMEV-2012-1-TR1-LEO05-35189) supported by the Turkish National Agency, Ministry of European Union. We would like to express our thanks to the Turkish National Agency on behalf of the entire project team.

KAYNAKLAR

Francisco J. P. (2011), An Integrated Electric Vehicle Curriculum, EVs, Dr. Şeref Soylu (Ed.), InTech.

Bümen N. T. (2006), A Revision of the Bloom’s Taxonomy, Education and Science, 31, 142 (3-14).

The Advanced Electric Drive Vehicle Education (AEDVE) Program, <http://www.iatn.net/naftc/>

Alternative Fuels and Advanced Vehicles, <http://www.afdc.energy.gov/vehicles/>

Infocar Training AB, <http://www.infocar.se>

Vocational Education Platform for Maintenance of Electric Vehicles, <http://www.vemev.eu>

ÜNİVERSİTELER İLE EĞİTİME İLİŞKİN SÜRDÜRÜLEN İŞBİRLİKLERİNİN FİRMALARIN ÖZÜMSEME KAPASİTESİNE ETKİSİ

THE EFFECTS OF COLLABORATION WITH UNIVERSITIES ABOUT EDUCATION ON FIRMS' ABSORPTIVE CAPACITY

Ali KILIÇ

Kara Harp Okulu, Savunma Bilimleri Enstitüsü, Ankara
alikilic33@yahoo.com

Fahri SAKARYA

Kara Harp Okulu, Savunma Bilimleri Enstitüsü, Ankara
sakaryafahri@gmail.com

ÖZET: Teknolojinin, örgüt dışındaki bilgi kaynaklarından edinilmesi sürecinde başarılı olabilmek için, alıcı örgütün yüksek seviyede 'özümseme kapasitesi(ÖK)'ne sahip olması gerekmektedir. Hızla artmakta olan rekabet ortamında hayatta kalabilmek ve örgüt dışındaki teknolojileri transfer edebilmek için, örgütlerin ÖK'lerini arttıracak değişkenlerin tespit edilmesi ve alınacak sonuçlara göre örgüt politikalarının ve stratejilerinin geliştirilmesi kritik bir gereklilik halini almıştır.

Bu çalışmada öncelikle literatürde geçen, örgütlerde ÖK'ni artıran faaliyetler tespit edilmiştir. Bu faaliyetler arasında yer alan, "firmaların teknoparklarda üniversiteler ile eğitime ilişkin kurdukları işbirlikleri (FÜEİ)" bağımsız değişken olarak seçilerek, Ankara'daki teknoparklara yerleşmiş 157 firmanın FÜEİ ve ÖK'lerinin seviyeleri ve FÜEİ'nin, ÖK'nin yordayıcısı olup olmadığı, yapılan ampirik çalışma ile tespit edilmiştir.

Anahtar Kelimeler: Örgütsel öğrenme, özümseme kapasitesi, teknoparklar, üniversite-sanayi işbirliği

ABSTRACT: To be successful in the process of acquiring technology from outside knowledge resources, the receiver organization must have a high level of absorptive capacity (AC). To be able to survive in a rapidly increasing competitive environment and to transfer outside knowledge to the organization, organizations should find out the variables which increase their AC and also they should determine organizational policies and strategies according to the results.

In this study, first of all the factors that increase AC are identified by reviewing the literature. Educational collaboration between firms and universities in technoparks (ECBFU) which is among these factors is chosen as independent variable and 157 firms in technoparks in Ankara is analyzed by an empirical study to find out the level of ECBFU, AC and to analyze if ECBFU effects AC.

Keywords: Organizational learning, absorptive capacity, technoparks, university-firm collaboration

1. ÖZÜMSEME KAPASİTESİ

Küreselleşen ve rekabetin giderek arttığı ve bilginin önemli bir çarpan olarak ön plana çıkmaya başladığı günümüzde, firmalar rakiplerinden daha hızlı bir şekilde çeşitli yetenekler geliştirmek ve sürekli yeni bir şeyler öğrenmek mecburiyetinde kalmaktadırlar (Teece ve Pisano, 1994). Bilgi, her geçen gün firmalar için daha fazla önem arz eden kaynaklardan biri haline almakta ve yalnızca sürekli olarak yeni bilgi üretebilen firmalar, rekabet avantajı kazanma sürecinde daha iyi bir pozisyon elde edebilmektedir (Nonaka ve Takeuchi, 1995).

Cohen ve Levinthal (1990) örgütlerin öğrenme yeteneklerinin dışarıdaki yeni bilgiyi tanıma, asimile etme ve uygulama konusunda, önemli bir yer tuttuğunu belirtmektedirler. Sun ve Anderson (2010) ise, ÖK'nin yeni bilgiyi edinme ve onu ticari ürünlere dönüştürebilme hedefinde önemli bir yeri olduğuna vurgu yapmışlardır. Bu yaklaşımla, özümseme kapasitesinin örgütsel öğrenme sürecinin tamamlayıcısı olarak bu süreçte önemli bir yer tuttuğu söylenebilir (Autio ve diğerleri, 2000). Bu yaklaşımla, ÖK arttıkça, örgütsel öğrenmenin seviyesinin de artacağı savunulması hatalı bir yaklaşım olmayacaktır (Tsai, 2001). Benzer şekilde, örgütsel öğrenme

sürecinde yaratılan yeni bilginin, var olan mevcut bilginin seviyesini artırdığı ve artan bu bilgi seviyesinin, örgütlerin ÖK'ni de artırdığı da gözlemlenmektedir (Kim, 1998).

Firmaların yeni ve dışarıdaki bir bilginin değerinin farkına varabilme, onu asimile etme ve ticari ürünlerde kullanabilme kabiliyeti, yenileşim yeteneklerini (inovasyon) artırma ve rekabet avantajı kazanma süreçlerinde de büyük öneme sahiptir. Bu kabiliyet ise büyük ölçüde, firmaların daha önceden sahip oldukları bilgi birikimlerinin bir fonksiyonudur. Sahip olunan öncül bilgi birikimi firmalara, yeni bir bilginin farkına varma, ondan faydalanma ve onu ticari bir ürüne dönüştürebilme yeteneği kazandırır ki bu yeteneğe daha önce de belirtildiği gibi ÖK, denmektedir (Cohen ve Levinthal, 1990). ÖK'nin, firmaların temel öğrenme yeteneklerinin ana temelini oluşturduğunu söylemek de mümkündür (Lane ve diğerleri, 2006).

ÖK ile ilgili çalışmalar, özellikle gelişmiş ülkelerde yoğun olarak yapılmış ve bu çalışmalar sonucunda araştırmacılar tarafından değişik tanımlar geliştirilmiştir. Zahra ve George (2002) ÖK'ni, firmaların dinamik bir örgütsel yetenek üretebilmek için bilgiyi elde ettiği, asimile ettiği, dönüştürdüğü, faydalandığı rutin ve süreçler bütünü olarak tanımlamışlardır. Murovec ve Prodan (2008) ise, ÖK'ni kısaca, "bir örgütün dışarıdaki bilgileri ticari ürünlere dönüştürebilme yeteneği" şeklinde açıklamışlardır.

ÖK, araştırmacılar tarafından edinme, asimile etme, dönüştürme ve faydalanma olmak üzere dört temel safhaya bölünmekle birlikte (Zahra ve diğerleri, 2002; Flatten ve diğerleri, 2011), Zahra ve George (2002), ÖK'nin potansiyel ve gerçekleştirilen ÖK olmak üzere, iki alt kümeye daha ayrılabilirliğini savunmaktadırlar. Onlara göre, potansiyel ÖK, edinme ve asimile etme safhalarını; gerçekleştirilen ÖK ise, dönüştürme ve faydalanma safhalarını kapsamaktadır.

Bilgi tabanlı rekabetin en kritik faktörlerden birisi olarak kabul edilen ÖK'nin (Zahra ve George, 2002) yeni birşeyler geliştirmek, bunu sürekli kılmak, uzun süre hayatta kalabilmek ve sürekli başarılar elde edebilmek için kritik bir gereklilik olduğu artık kabullenilmiş bir gerçektir. Çünkü ÖK, firmanın yenilik yapması için gerekli olan bilgi tabanını kuvvetlendirme ve bütünlemede öncü bir şarttır (Lane ve diğerleri, 2006).

İçerdiği bu önem doğrultusunda, firmaların rekabet ortamında hayatta kalmasının temel etkenlerinden olan ÖK'ni artıran faaliyetlerin tespit edilmesi ve gerekli uygulamaların başlatılmasının mikro düzeyde firmalar, makro düzeyde ise endüstriler ve ülkeler için büyük bir gereklilik haline geldiği söylenebilir. Bu kapsamda, tarafımızdan özümleme kapasitesini artıran faaliyetler, konuyla ilgili yazım alanının incelenmesi sonucu tespit edilmiş ve özet olarak Tablo-1'de sunulmuştur. Tabloda sunulan faaliyetlerin ÖK'ni artırdığına dair çalışmalar yazarları ile birlikte verilmiş fakat söz konusu çalışmaların sonucunda elde edilen, hangi değişkenler ne kadar etkilemektedir, ayrıntısına girilmemiştir.

Tablo-1: ÖK'nini Artırdığı Tespit Edilen Faaliyetler

ÖK'Nİ ARTIRAN FAALİYETLER	
S.NU.	FAALİYET KONUSU
1	Çalışanların öğrenme kabiliyetlerinin artırılması (Yazan, 2007)
2	Çalışanların problem çözme yeteneklerinin artırılması (Yazan, 2007)
3	İşe alınacakların doğru bir şekilde seçilmesi (Othman ve diğerleri, 2011)
4	Çalışanların öğrenmeye ve yeni teknolojileri benimsemeye olan istekliliklerinin artırılması (Ashekele ve diğerleri, 2011)
5	Çalışanların tecrübe ve yeteneklerinin artırılması (Scribd Home Page[web], 2011)
6	Dışarıdaki bilgileri, çalışanların anlayabileceği bir dile çevirebilen uzmanların istihdamı (Cohen ve Levinthal, 1990)
7	Edinilen bilgilerin biriktirilmesi ve muhafazası (Cohen ve Levinthal, 1990)
8	Çalışanların kullandığı ortak bir lisanın oluşturulması (Szulanski, 1996; Cohen ve Levinthal, 1990)
9	Güncel bilimsel ve teknolojik bilgilerin edinilmesi (Yazan, 2007)
10	Örgütsel hafızanın oluşturulması (Zahra ve George, 2002)
11	Yeni bilgi yaratabilme yeteneğinin artırılması (Matusik ve Heeley, 2005)
12	Dışarıda var olan bilgileri keşfetmek, anlamak ve özümleme süreçlerinin geliştirilmesi (Cohen ve Levinthal, 1990)
13	Ar-Ge yeteneğine sahip olmak ve bu yeteneğin geliştirilmesi (Cohen ve Levinthal, 1990)
14	Ar-Ge'ye yatırım yapılması (Yazan, 2007)
15	Bilgi ve teknoloji paylaşım yeteneği oluşturması (Li-Hua, 2004)
16	Örgüt içi veya örgütler arası bilgi, fikir, prensip, model v.b. değiş-tokuş uygulamalarının sayısının artırılması (Szulanski, 1996)
17	Bilgi ve teknoloji yayılım kanallarının oluşturulması (prosedürler, kurallar, veritabanları, eğitim, usta-çırak ilişkisi, takım çalışması, konuşmalar, kişilerarası iletişim ve etkileşim) (Chinho ve diğerleri, 2002)

18	Kimin, neyi bildiğinin bilinmesine dönük uygulamaların oluşturulması (Yazan, 2007)
19	Çalışanların kurslara, kongrelere, çalıştaylara v.b. katılmasının sağlanması (Staples, 2001)
20	Üniversiteler, araştırma merkezleri gibi dış bilgi kaynakları ile iletişim bağlarının kurulması ve kullanılması (Henderson ve Cockburn, 1998)
21	Güçlü örgüt yapısı ve yönetim sistemlerinin oluşturulması (Kedia ve Bhagat, 1988)
22	Pozitif değişim sergileyen açık çalışma kültürleri yaratılması (Levinson ve Ashai, 1995)
23	Eğitim yatırımları yapılması (Yazan, 2007)

Tablo-1’de özetlenen faaliyetler değerlendirildiğinde, bu faaliyetlerin birçoğunun teknoparklarda amaç olarak belirlenen faaliyetler olduğu, kamu erkinin koyduğu yasalar ve sunduğu kaynaklar ile bu tür faaliyetleri gerçekleştirmeye yönelik çalışmalar yaptığı gerçeğinden hareketle, sonraki bölümlerde teknopark faaliyetlerinden olan FÜEİ’nin ÖK üzerindeki etkisi incelenmiştir.

2. FÜEİ VE FİRMALARIN ÖK’LERİNE ETKİSİ

Yurt dışından teknoloji transferi yapmanın giderek daha zor bir hal aldığı günümüz şartlarında ülkeler, kendi teknolojilerini kendilerinin geliştirdikleri ortamlar yaratmak zorunda kalmaktadırlar. Bu tür ortamların başında ise teknoparklar gelmektedir. Teknoparklar, teknoloji ediniminin gerçekleştirildiği, yeni ürünlerin geliştirildiği ve diğer ülkelerle rekabet edebilmek adına ülkenin ve firmaların yeteneklerine katkıda bulunan kuruluşlardır (Kılıç, 2009)

Teknoparkların esas kuruluş amacı, üniversite, sanayi ve devlet işbirliğini sağlayarak, millî politikalara uygun bir şekilde teknoloji geliştirmeyi teşvik etmek, yaratılacak sinerji vasıtasıyla bölgesel ve ekonomik gelişmeyi hızlandırmak şeklinde ortaya konulabilir (Özdemir, 2006). Teknopark içi işbirliklerinden biri olan üniversite firma işbirliği, örgütler arası ilişkilerin pek çok etkileşim formunu içermektedir (Carayol, 2003). Teknoparklar sayesinde, üniversitelerdeki teorik bilgi, sanayideki pratik uygulama ile birleşebilmekte ve bu birliktelik hem üniversitelere hem de sanayiye fayda sağlamaktadır. Bu kapsamda, teknopark içerisinde, üniversite ile firmalar arasında var olan çeşitli işbirliği uygulamaları ve bağlantılarını şu şekilde özetlemek mümkündür (Quintas ve diğerleri, 1996; Erün, 2012):

- Eğitim ve öğretim imkânı,
- Kiracı firmanın, üniversitenin müşterisi olması,
- Mezunlara ve akademisyenlere iş verilmesini de içeren insan hareketleri,
- Ortak kaynakların, teçhizatın ve tesislerin kullanımı ve özel uzmanlıklara erişim olanağı,
- Firma destekli üniversite araştırmaları,
- Resmi veya gayri resmi bilgi akışı,
- Üniversite öğrencilerine staj imkânı sağlanması,
- Üniversite ile firmanın belli alanlarda ortak tez çalışmaları yürütmesi,
- Firma tarafından ihtiyaç alanlarına dönük alanlarda üniversitede yapılan yüksek lisans ve doktora çalışmalarına burs, proje desteği ve mali destek sağlanması,
- Üniversitedeki akademik personelin, firmalara danışmanlık yapması,
- Kiracı firma personelinin, üniversitedeki bilimsel yayınlara erişimi,
- Kiracı firmanın, üniversitenin araştırma altyapısı ve laboratuvarlarından faydalanması,
- Kiracı firma tarafından yürütülen araştırma projelerine, proje süresince üniversiteden akademisyen desteği alınması.

Vedovello (2000); Quintas ve diğerleri (1996) ile Erün (2012)’den farklı olarak, teknopark içinde bulunan firmaların bağlantı, etkileşim ve işbirliklerini aktör bazında değil de uygulama bazında değerlendirmiş ve yapmış olduğu çalışmada, gayri resmi bağlar, insan kaynakları bağlantıları ve resmi bağlardan oluşan bir taksonomiyi kullanmıştır. Söz konusu taksonomiye göre;

Gayri resmi bağlar;

- Üniversite akademik personeli ile kişisel iletişim,
- Literatüre/teknik raporlara ulaşım,
- Üniversite araştırmalarına erişim,
- Seminer ve konferanslara katılım,
- Genel eğitimlere katılım.

İnsan kaynakları ile ilgili bağlar;

- Öğrencilerin projelere katılımı,
- Yeni mezunların firmalarda istihdamı,
- Daha tecrübeli bilim adamı ve mühendislerin istihdamı,
- Üniversitede firma personeli için resmi olarak düzenlenmiş eğitimler.

Resmi bağlar;

- Üniversite akademisyenlerinin firmalara danışmanlık hizmeti vermesi,
- Üniversitede test ve analizler yaptırılması,
- Araştırma sözleşmeleri yapılması,
- Müşterek araştırmaların yapılması, olarak tanımlanmaktadır.

FÜEİ içerisinde mevcut olan faaliyetler değerlendirildiğinde, bu faaliyetler ile firmaların ÖK'lerini artıran faaliyetler arasında önemli bir benzeşim olduğu görülmüştür. Sözü edilen benzeşen faaliyetler sentezlenerek Tablo-2'de özetlenmiştir.

Tablo-2: FÜEİ Konuları ile ÖK'ni Arttıran Eylemler Benzeşim Tablosu

S.NU.	FAALİYET KONUSU
1	Firma personeline sağlanan eğitim ve öğretim imkânının artırılması (Quintas ve diğerleri, 1996)
2	Mezunlara ve akademisyenlere iş verilmesini de içeren insan hareketlerinin artırılması (Quintas ve diğerleri, 1996)
3	Firma destekli üniversite araştırmalarının sayısının artırılması (Quintas ve diğerleri, 1996)
4	Resmi veya gayri resmi bilgi akışının artırılması (Quintas ve diğerleri, 1996)
5	Üniversite öğrencilerine staj imkanı sağlanması (Erün, 2012)
6	Üniversite ile firmanın ortak yürüttükleri tez çalışmalarının sayısının artırılması (Erün, 2012)
7	Firma tarafından ihtiyaç alanlarına dönük alanlarda üniversitede yapılan yüksek lisans ve doktora çalışmalarına daha çok destek sağlanması (Erün, 2012)
8	Üniversitedeki akademik personelin, firmalara sunduğu danışmanlık hizmetlerinin artırılması (Erün, 2012)
9	Firma personelinin, üniversitedeki bilimsel yayınlara erişiminin artması (Erün, 2012)
10	Firmanın, üniversitenin araştırma altyapısı ve laboratuvarlarından daha çok faydalanması (Erün, 2012)
11	Firma tarafından yürütülen araştırma projelerine, proje süresince üniversiteden daha çok akademisyen desteği alınması (Erün, 2012)

Ortaya çıkan bu sentezlenmiş benzeşim tablosu neticesinde, FÜEİ'nin firmaların ÖK'ni arttırabileceği tezi ile bundan sonraki bölümde oluşturulmuş araştırma soruları ve hipotez 157 firmadan elde edilen verilerle sınanmıştır.

3. ARAŞTIRMA

4. a. Araştırmanın Konusu, Amacı ve Kapsamı

Bu çalışmada, Ankara'da bulunan beş teknopark (ODTÜ Teknokent, Bilkent Cyberpark, Hacettepe Teknokent, Gazi Teknopark, Ankara Üniversitesi Teknoloji Geliştirme Bölgesi) içerisinde yer alan firmalar aracılığı ile FÜEİ'nin firmaların ÖK'ni ne kadar etkilediği sorusuna cevap aranmıştır. Bu amaçla, FÜEİ ile firmaların ÖK'lerinin seviyeleri ortaya konmuş ve FÜEİ ile firmaların ÖK'leri arasında anlamlı bir ilişki olup olmadığı basit doğrusal regresyon analizi ile sınanmıştır. Araştırma için geliştirilen ölçekler, Ankara'daki Teknoparklarda bulunan toplam 157 firmaya uygulanmıştır.

b. Araştırmanın Modeli ve Hipotez

(1) Araştırmanın Modeli

Araştırmanın amacını ifade eden araştırma modeli, literatür incelemesi sonucunda benzeşim tablosu ile ortaya konulan ve Tablo-2 de sunulan ilişkilerin varlığına dayanarak oluşturulmuştur. Araştırmada geliştirilen model Şekil-1'de sunulmuştur.

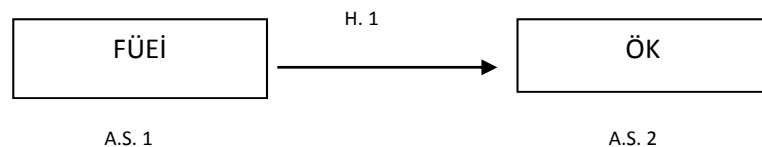

Şekil-1: Araştırmada Geliştirilen Model

(2) Araştırma Soruları ve Hipotez

Araştırmanın amacına yönelik olarak aşağıdaki araştırma soruları (A.S.) ve hipoteze yanıt aranmıştır:

- A.S.1 : Ankara'daki teknoparklar içerisindeki FÜEİ'nin seviyesi nedir?
A.S.2 : Ankara'daki teknoparklarda bulunan firmaların ÖK'lerinin seviyesi nedir?
H.1 : FÜEİ'nin seviyesinin, teknoparklarda bulunan firmaların ÖK'leri üzerinde pozitif bir etkisi vardır.

c. Yöntem

(1) FÜEİ Ölçeği

FÜEİ'nin seviyesini tespit etmek amacıyla Erün (2012) tarafından geliştirilen ve geçerliliği sınanan “teknopark içi işbirlikleri ölçeği” kullanılmıştır. Ölçekte “FÜEİ” boyutu toplam 4 sorudan oluşmaktadır. Ölçeğin faktör yapısını doğrulamak için uygulanan doğrulayıcı faktör analizi (Büyüköztürk, 2006) sonucunda, ölçeğin faktör yapısı doğrulanmıştır. Veri setinin faktör analizi için uygunluğunu test etmek için Kaiser-Meyer-Olkin (KMO) örneklem yeterliliği ölçütü kullanılmıştır. Yapılan analiz neticesinde KMO değeri 0,907 (çok iyi) olarak tespit edilmiştir.

Bireylerin ölçek maddelerine verdikleri cevaplar arasındaki tutarlılık ve ölçeğin ölçmek istenen özelliği ne derece doğru ölçtüğünü sınamak amacıyla Cronbach Alfa (α) katsayısı ile güvenilirlik analizi yapılmıştır (Büyüköztürk, 2006). Yapılan analiz neticesinde, ölçek yüksek derecede güvenilir ($\alpha=0,936$) bulunmuştur.

(2) ÖK Ölçeği

Teknoparklarda faaliyet gösteren firmaların ÖK'lerinin seviyelerini ölçmek amacıyla, Flatten ve diğerleri (2011)'nin firmaların özümseme kapasitelerini ölçmek amacıyla hazırlamış oldukları soru havuzundan toplam 36 soru ve Andrawina ve diğerleri (2008) nin potansiyel ve gerçekleştirilen özümseme kapasitelerini ölçmek için hazırladıkları ölçekten toplam 13 soru alınarak, 49 maddelik bir soru havuzu oluşturulmuştur.

Adı geçen iki ölçeğin Türkçe'ye uyarlanması sürecinde sırasıyla; dil denkliği ve ölçek maddelerinin anlamsal ve kavramsal açıdan denkliklerinin sağlanıp sağlanmadığı kontrol edilmiştir. Yapılan inceleme neticesinde, kapsam geçerliliğini sağlamayan 14 soru ölçekten çıkartılmıştır. Ölçek uyarlama sürecinin son aşamasında ise 115 kişilik bir grupla anketin ön uygulaması yapılmış ve edinim (E), asimilasyon (A), dönüştürme (D) ve faydalanma (F) olmak üzere 4 boyutlu faktör yapısı doğrulanmıştır. Bu 4 faktör ile toplam varyansın %55,5'i açıklanabilmiştir.

Veri setinin faktör analizi için uygunluğunu test etmek için Kaiser-Meyer-Olkin (KMO) örneklem yeterliliği ölçütü kullanılmış ve yapılan analiz neticesinde KMO değeri 0,829 (çok iyi) olarak tespit edilmiştir. Bunun yanında, Cronbach Alfa (α) katsayısı ile güvenilirlik analizi yapılmış (Büyüköztürk, 2006) ve ölçek yüksek derecede güvenilir ($\alpha=0,830$) bulunmuştur.

5. BULGULAR VE YORUMLAR

a. Araştırma Sorusu 1: Ankara'daki teknoparklar içerisindeki FÜEİ'nin seviyesi nedir?

FÜEİ'nin seviyesinin tespit edilmesi amacıyla oluşturulan bu araştırma sorusu ile ilgili yapılan analiz sonucunda, FÜEİ'nin normal düzeyde (2,75) olduğu tespit edilmiştir. FÜEİ'nin seviyesi Tablo-3'te gösterilmiştir.

Tablo-3: FÜEİ'nin Seviyesi

DEĞİŞKEN	N	ALINAN ORTALAMA PUAN	STANDART SAPMA	SEVİYE İFADESİ
Üniversite ile Eğitime İlişkin İşbirlikleri	157	2,75	1,04	NORMAL*

* Beşli likert ölçeğinde; çok düşük, düşük, normal, yüksek, çok yüksek ifadeleri kullanılmıştır.

Teknoparkların kuruluş amaçlarından birisinin de teknopark içerisinde işbirliği ortamı sağlamak olduğu düşünüldüğünde, teknopark içi işbirliklerinin seviyesinin yüksek veya çok yüksek düzeylerde çıkması beklenmektedir. Çünkü firmalar için ana amaç olan teknoloji edinimi, firma içerisinde geliştirilmenin yanında diğer örgütlerden teknoloji transferi yoluyla da sağlanması gereken bir olgudur. FÜEİ'nin seviyesinin 2.75 lik bir düzeyde çıkmasının çeşitli problemlerin varlığına işaret ettiği düşünülmektedir. Bu konuda yapılan başkaca çalışmalar (Kılıç,2009; Erün 2012), bizim bu bulgumuzu destekler niteliktedir.

b.Araştırma Sorusu 2: Ankara'daki teknoparklarda bulunan firmaların ÖK'lerinin seviyesi nedir?

Firmaların ÖK'nin seviyesinin tespit edilmesi amacıyla oluşturulan bu araştırma sorusu ile ilgili yapılan analiz neticesinde, teknopark firmalarının ÖK'nin yüksek düzeyde (4,08) olduğu tespit edilmiştir. Yine ÖK'nin her bir boyutunda da araştırmaya katılan firmaların yüksek veya çok yüksek seviyelerde olduğu görülmüştür. Firmaların ÖK seviyeleri toplu olarak Tablo-4'te verilmiştir.

Tablo-4: Toplam Olarak ve Boyut Bazında ÖK Seviyeleri

DEĞİŞKEN	ORTALAMA	SEVİYE
ÖK	4,08	YÜKSEK
BOYUTLAR	ORTALAMA	SEVİYE
Edinim	3,93	YÜKSEK
Asimilasyon	4,00	YÜKSEK
Dönüştürme	4,17	YÜKSEK
Faydalanma	4,24	ÇOK YÜKSEK

Firmaların ÖK'lerinin yüksek veya çok yüksek düzeylerde çıkması beklenen bir durumdur. Çünkü teknoparklara giriş yapan tüm firmaların, buralara katılım yapabilmeleri için bazı öncül şartları sağlamış olmaları, bilgi çağı firmalarının bazı nitelik ve özelliklerine sahip olmaları gerekmektedir. Bunun yanında, teknopark içerisinde teknoloji transferi faaliyetini gerçekleştirebilmek için de firmaların ortalamasının üzerinde bir ÖK'ne sahip olmaları da bir zorunluluktur. Fakat teknopark aktörleri ile teknoloji bilgisini paylaşmak ve teknoloji transferini gerçekleştirmek için ÖK'nin tek başına yüksek olmasının yeterli bir durum olmayacağı da değerlendirilmektedir. Çünkü ÖK firmasının sahip olduğu bir yetenektir. Teknoloji transferi içinse FÜEİ'nin de yapılması, yani söz konusu yeteneğin faydalı hale dönüştürülmesi gerekliliği mevcuttur.

c.Hipotez: FÜEİ'nin seviyesinin, teknoparklarda bulunan firmaların ÖK'leri üzerinde pozitif bir etkisi vardır.

FÜEİ'nin seviyesi ile teknoparklarda bulunan firmaların ÖK'leri arasında anlamlı bir ilişki olup olmadığını test etmek için basit doğrusal regresyon analizi yöntemi kullanılmıştır. Analiz neticesinde elde edilen bulgular Tablo-5'te gösterilmiştir.

Tablo-5: FÜEİ'nin Firmaların ÖK'leri Üzerine Etkisi

Bağımsız Değişken	Standart Beta (β)	t	Sig.	Ortalama	Korelasyon
Sabit	3,66	43,026	0,000	-	-
FÜEİ	0,156	5,39	0,000	2,751	0,397*
R ² =0,158		F=29,054		σ=0,000	
Bağımlı Değişken: ÖK					
* %99 Anlamlılık Düzeyinde					

Oluşturulan regresyon modeli istatistiksel olarak %99 anlamlılık düzeyinde anlamlı çıkmıştır (σ<0,01). R² değeri 0,158 olarak bulunmuştur. Buna göre FÜEİ, firmaların ÖK'lerindeki değişimin %15,8'ini açıklamaktadır.

FÜEİ ile firmaların ÖK'leri arasında %99 anlamlılık düzeyinde pozitif bir korelasyon (0,397) olduğu tespit edilmiştir. Ayrıca regresyon modelinde oluşan β katsayılarının da anlamlı oldukları (β sabit=3,66 $\sigma < 0,01$; β FÜEİ=0,156 $\sigma < 0,01$) belirlenmiştir. Elde edilen tüm bu bulgular sonucunda ortaya çıkan regresyon modeli şu şekildedir:

$$\text{ÖK} = 3,66 + 0,156 * \text{FÜEİ}$$

Sonuç olarak çalışma için kurguladığımız H1 hipotezi doğrulanmıştır. Yani FÜEİ ile teknoparklarda bulunan firmaların ÖK'leri arasında anlamlı (%99 anlamlılık düzeyinde) bir ilişki vardır. Oluşturulan basit doğrusal regresyon modelinden de anlaşılacağı üzere, FÜEİ'nin ortalamasındaki bir birimlik artışın, firmaların ÖK'lerini 0,156 birim artıracığı görülmüştür. Dolayısıyla, iki değişkenin aralarında güçlü bir neden-sonuç ilişkisinin bulunduğu değerlendirilmiştir.

Bu güçlü neden-sonuç ilişkisi düşünüldüğünde, FÜEİ'nin seviyesinin artırılmasının, firmaların ÖK'lerine büyük katkılar sağlayabileceği ve böylelikle, örgütsel öğrenme yeteneklerinin de artacağı söylenebilir.

6. SONUÇ VE TARTIŞMA

Literatür araştırması sonucunda, ÖK'nin teknoloji edinim süreçlerini kolaylaştırarak firmalara rekabet avantajı kazandırdığı (Dominguez ve diğerleri, 2007), teknoloji transferi için kritik öneme sahip olduğu ve bundan dolayı, firmaların güçlü bir ÖK'ne sahip olmaları gerektiği tespitlerine ulaşılmıştır (Lin ve diğerleri, 2004).

Günümüz rekabet ortamında firmaların tek başlarına hayatta kalabilmeleri kolay olmadığından, firmaların üniversiteler, araştırma kurumları, diğer firmalar, devlet vb. ile işbirliği içerisinde çalışmalarını gerekmektedir. Firmalara böyle bir işbirliği ortamını sağlayan kuruluşların başında ise teknoparklar gelmektedir.

Dışarıda varolan bilgileri keşfetmek ve özümsemek (Cohen ve Levinthal, 1990), örgüt içi veya örgütler arası bilgi, fikir vb. değiş-tokuşu yapmak (Szulanski, 1996), üniversiteler gibi dış bilgi kaynakları ile iletişim bağları kurmak (Henderson ve Cockburn, 1998) ve yeni bilgi yaratabilmek (Matusik ve Heeley, 2005) gibi hususların, firmaların teknoloji transferinde öncül gereklilik olan ÖK'lerinin gelişimine katkıda bulunabileceği, araştırmalar ile ortaya konulmuştur. Türkiye'de bu konuda yapılmış olan herhangi bir araştırmaya rastlanmamıştır.

Literatür incelemesi ve yapılan tüm bu değerlendirmeler de dikkate alınarak, FÜEİ'nin, firmaların ÖK'lerine bir katkı sağlayıp sağlamadığı analiz edilmiştir. Bu kapsamda öncelikle, FÜEİ'nin ve ÖK'nin seviyeleri tespit edilmiştir. Yapılan araştırma ve analizler sonucunda, FÜEİ'nin seviyesinin normal ve firmaların ÖK'lerinin yüksek düzeyde olduğu görülmüştür. Teknopark firmalarının ÖK'lerinin yüksek olması beklenen bir durum iken, FÜEİ'nin seviyesinin düşük olması problem olarak değerlendirilmiş, fakat bu araştırmanın asıl araştırma hedefi olmadığı için daha fazla derinlemesine araştırılmamıştır. Bu konuda teknopark yönetim firmalarına ve kamuya düşen bazı görevler olduğu değerlendirilmiştir.

Araştırmanın asıl hedefi olan, FÜEİ'nin teknoparklarda bulunan firmaların ÖK'leri üzerinde güçlü bir etkisi olup olmadığına ilişkin yapılan analizler neticesinde ise bu iki değişken arasında güçlü bir ilişki olduğu tespit edilmiştir. Bu tür işbirliklerinin, firmaların ÖK'leri üzerindeki güçlü düzeydeki etkisi düşünüldüğünde, sadece araştırmanın örneklemini oluşturan firmaların değil, tüm bilgi tabanını geliştirmek isteyen firmaların, ÖK'lerinin seviyelerini artırmak için, FÜEİ'nin seviye ve nitelik yönünden yeterliliğinin artırılması gerektiği düşünülmüştür. Böylelikle, firmaların ÖK'lerinin gelişimine önemli miktarda katkı sağlanabileceği değerlendirilmiştir. Bu değerlendirme, Bigliardi ve diğerleri (2006)'nin, üniversite ile firmalar arasında kurulan işbirliği miktarının, firmaların ÖK'lerini artırdığı ve teknoloji transfer performanslarına katkıda bulunduğu bulgusunu destekler niteliktedir.

Üniversiteler ile güçlü iletişim bağları kurmak, FÜEİ'nin seviyesinin artmasına ve dolayısıyla Ramirez ve Dickenson (2010)'un da çalışmalarında belirttikleri gibi, firmaların ÖK'lerinin artmasına katkıda bulunmaktadır. Bu bulgu, Bellavista ve Sanz (2009)'ın, üniversiteler ile etkileşim içinde olan firmaların, yaratıcı ürün ve hizmetlerinin artacağı değerlendirilmesini de desteklemektedir.

Yapılan analizler sonucunda, FÜEİ'nin artmasına katkıda bulunan faktörlerden, üniversite öğrencilerine yarı zamanlı iş ve staj imkânı sağlanması, üniversitede yapılan tez çalışmalarına firma personeli tarafından teknik

destek verilmesi gibi hususların da firmaların ÖK'lerine katkıda bulunduğu tespit edilmiştir. Bu tespit, literatürde örgütler arası personel değişiminin ÖK'ni artırdığı ve firmaların teknoloji transferi yapmalarını kolaylaştırdığına yönelik pek çok çalışma sonucunu desteklemektedir (Hernard Mc.Fadyen, 2008; Bellavista ve Sanz, 2009; Westhead ve Batstone, 1998; Miles, 2008).

Bu araştırma hâlihazırda ÖK'lerinin yüksek olması beklenen teknopark firmaları üzerinde yapılmakla birlikte burada ortaya konulan sonuçların, teknopark dışındaki firmalara uygulanması bir gereklilik olarak belirmiştir. Türkiye'deki teknoparklarda faaliyet gösteren firmaların teknoloji transferini gerçekleştirecek yeterliliklere ve kapasiteye sahip olması, Türkiye ekonomisi ve Türkiye'nin içinde yer aldığı küresel rekabet düşünüldüğünde çok önemli katkılar sağlayacaktır. Bu nedenle bilgi ve teknoloji kazanımını yaygınlaştırmak, KOBİ düzeyindeki firmaların ileri teknoloji bilgi düzeylerine ulaşmasını sağlamak hedefleri ile üniversiteler ile eğitime dair işbirliklerinin artırılmasına dönük politikalar ve planlar geliştirilmeli ve uygulanmalıdır.

KAYNAKÇA

- ANDRAWINA, Luciana ve diğerleri. (2008), "The effect of Interorganizational Relationship on Knowledge Sharing Capability and Absorptive Capacity", *Proceedings of the 9th Asia Pasific Industrial Engineering & Management Systems Conference*, Indonesia, , 837-848
- ASHEKELE, H. M. ve K. MATENGU. (2008), "Success Factors in Technology Transfer to SME's: Rundu Woodwork Common Facility Center", *Portland International Conference on Management of Engineering&Technology 2008*, Güney Afrika,
- AUTIO, E. ve diğerleri. (2000), "Effects of age at entry, knowledge intensity, and imitability on international growth", *Academy of Management Journal*, 43, 909-924
- BELLAVISTA, J. ve L. SANZ. (2009), "Science and Technology Parks: Habitats of Innovation: Introduction to Special Section", *Science and Public Policy*, 36, 499-510
- BIGLIARDI, Barbara ve diğerleri. (2006), "Assessing Science Parks' Performances: Directions From Selected Italian Case Studies", *Technovation*, 26, 489-505
- BÜYÜKÖZTÜRK, Ş. ve Y. GÜLBAHAR. (2006), "Değerlendirme Tercihleri Ölçeğinin Türkçe'ye Uyarlanması", *Hacettepe Üniversitesi Eğitim Fakültesi Dergisi*, 35, 2008, 148-161
- BÜYÜKÖZTÜRK, Şener. *Sosyal Bilimler İçin Veri Analizi El Kitabı*, Ankara, Pegem Yayıncılık,
- CARAYOL, Nicolas. (2003), "Objectives, Agreements and Matching in Science-Industry Collaborations: Reassembling the Pieces of the Puzzle", *Research Policy*, 32, 887-908
- CHINHO, Lin ve diğerleri. (2002), "The Critical Factors for Technology Absorptive Capacity", *Industrial Management + Data Systems*, 102, 300-308
- COHEN, W. M. ve D. A. LEVINTHAL. (1990), "Absorptive Capacity:A New Perspective on Learning and Innovation", *Administrative Science Quarterly*, 35, 128-152
- DOMINGEZ, D.C. ve diğerleri. (2009), "The Impact of Absorptive Capacity on Technological Acquisitions Engineering Consulting Companies", *Technovation*, 27, 417-425.
- ERÜN, Tayfun. (2012), Ankara'daki Teknopark Firmalarının Teknopark İçerisindeki İşbirliği Uygulamalarının Teknoloji Transfer Performansı Üzerine Etkisi, *Yayımlanmış Yüksek Lisans Tezi*, Ankara, Kara Harp Okulu Savunma Bilimleri Enstitüsü Teknoloji Yönetimi Ana Bilim Dalı
- FLATTEN, Tessa ve diğerleri. (2011), "A Measure of Absorptive Capacity: Scale Development and Validation", *European Management Journal*, 29, 98-116
- HAMBLETON, R. K. ve L. PATSULA. (1999), "Increasing the Validity of Adapted Tests: Myths to be Avoided and Guidelines for Improving Test Adaptation Practices", *Journal of Applied Testing Technology*, 1, 1-13
- HENDERSON, R. ve I. COCKBURN. (1998), "Absorptive Capacity, Coauthoring Behavior, and the Organization of Research in Drug Discovery", *Journal of Industrial Economics*, 46, 2, 157-182
- HERNARD, D. H. ve M. A. MCFADYEN. (2008), "Making Knowledge Workers More Creative", *Research Technology Management*, 52, 40-46

- KEDIA, B. ve R. S. BHAGAT. (1988), "Cultural Constraints on Transfer of Technology Across Nations: Implications for Research in International and Comparative Management", *Academy of Management Review*, 13, 4, 559-571
- KILIÇ, Ali. (2009), Ankara'daki Teknoparklarda Türk Savunma Sanayi Tarafından Sürdürülen Teknoloji Transfer Uygulamalarının Analizi: Odtü Teknopark ve Bilkent Cyberpark Uygulamaları *Doktora Tezi*, Ankara, Kara Harp Okulu Savunma Bilimleri Enstitüsü Teknoloji Yönetimi Ana Bilim Dalı
- KIM, L. (1998), "Crisis construction and organizational learning: capability building in catching-up in Hyundai Motor", *Organization Science*, 9, 506-521
- LANE, Peter ve diğerleri. (2006), "The Reification of Absorptive Capacity: A Critical Review and Rejuvenation of the Construct", *Academy of Management Review*, 31, 4, 833-863
- LEVINSON, N. S. ve M. ASAHI. (1995), "Cross-national Alliances and Interorganizational Learning", *Organisational Dynamics*, 24, 2, 50-63
- Lİ-HUA, Richard. (2004), *Technology and Knowledge Transfer in China*, İngiltere, Ashgate Publishing Limited,
- LIN, C. ve diğerleri. (2004), "The Impact of Terchnology Absorptive Capacity on Technology Transfer Performance", *Int.J.Technology Transfer and Commercialization*, 3, 384-409.
- MATUSIK, S. F. ve M. B. HEELEY. (2005), "Absorptive Capacity in Software Industry: Identifying Dimensions That Affect Knowledge and Knowledge Creation Activities", *Journal of Management*, 31, 4, 549-572
- MILES, Ian. (2008), "Patterns of Innovation in Service Industries", *IBM Systems Journal*, 47, 115-128
- MUROVEC, N. ve I. PRODAN. (2008), "The Influence of Organizational Absorptive Capacity on Product and Process Innovation", *Organizacija*, 41, 43-49
- NONAKA, I. ve H. TAKEUCHI. (1995), *The Knowledge Creating Company*, New York, Oxford University Press,
- OTHMAN, Ahmad ve diğerleri. (2011), "Development of Absorption Capability Attributes for Technology Transfer Performance: A Pilot Study in National Automotive Industry", *International Management Conference*, Malezya,
- ÖZDEMİR, Muhsin Tamer. (2006), Türkiye'deki Teknopark Girişimlerinin Mevcut Durumu ve Dünyadaki Örnekler Doğrultusunda Türkiye için Model Önerisi, *Savunma Sanayi Müsteşarlığı Uzmanlık Tezi*, Ankara, Savunma Sanayi Müsteşarlığı
- QUINTAS, Paul ve diğerleri. (1996), *The Sciencepark Evaluation Handbook*, Technopolis, Milton Keynes,
- RAMIREZ, M. ve P. DICKENSON. (2010), "Gatekeepers, Knowledge Brokers and Inter-Firm Knowledge Transfer in Beijing's Zhongguancun Science Park", *International Journal of Innovation Management*, 14, 93-122
- Scribd İnternet Sitesi, (2011), "The Importance of Absorptive Capacity in Technology Transfer Process", 12 Kasım <<http://www.scribd.com/doc/17174708/Development-in-Defense-Industry-in-Technology-Transfer>>
- STAPLES, Sandy. (2001), "A study of Remote Workers and Their Differences from Non-remote Workers", *Journal of End User Computing*, 13, 2, 3-14
- SUN, P.Y.T. ve M.H. ANDERSON. (2010), "An Examination of the Relationship Between Absorptive Capacity and Organizational Learning, and a Proposed Integration", *International Journal of Management Reviews*, 130-150
- SZULANSKI, Gabriel. (1996), "Exploring Internal Stickiness: Impediments to the Transfer of Best Practice within the Firm", *Strategic Management Journal*, 17, 27-43
- TEECE, D. ve G. PISANO. (1994), "The Dynamic Capabilities of Firms: An Introduction", *Industrial and Corporate Change*, 3, 3, , 537-556
- TSAI, W. (2001), "Knowledge transfer in intraorganizational networks: effects of network position and absorptive capacity on business unit innovation and performance", *Academy of Management Journal*, 44, 996-1004

VEDOVELLO, Conceiçao. (2000), "Science Parks and University-Industry Links: A Comparative Analysis Between a British and a Portuguese Experience", *Int. J. Services Technology and Management*, 1, 358-374

WESTHEAD, P. ve S. BATSTONE. "Independent Technology Based Firms: The Perceived Benefits of a Science Park Location", *Urban Studies*, 35, 1998, 2179-2219

YAZAN, Abdurrahman. Teknoloji Transferinde Özümseme Kapasitesinin Önemi ve Özümseme Kapasitesinin Geliştirilmesi, *Yüksek Lisans Projesi*, İstanbul, Beykent Üniversitesi Sosyal Bilimler Enstitüsü, 2007

ZAHRA, S. ve G. GEORGE. "Absorptive Capacity: A Review, Reconceptualization, and Extension", *Academy of Management Review*, 27, 2, 2002, 185-203

THE LIFE AND SCIENTIFIC METHODS OF MEHMED TAHİR FROM BURSA

Fatma KORKMAZ HAZAR
Balıkesir İstanbulluoğlu Anatolian Teacher Training School
fatmakorkmazhazar123@hotmail.com

Abstract: Mehmet Tahir from Bursa was Mustafa Kemal's teacher from Thessaloniki Military Junior High School. At the period he lived, he was called as "the greatest bibliography scholar of the Turks". Mr. Tahir was born in Bursa in 1861. He graduated from the Military Academy in 1883 with the rank of Infantry Lieutenant. He had worked in Skopje, Bitola and Thessaloniki Military Junior High Schools not only as a teacher but also a principal. He took place in Motherland and Liberty Association as one of the founders whose Thessaloniki department was opened by Mustafa Kemal in 1906. After participating in The Committee of Union and Progress between the years 1908 and 1911, he worked as a deputy in the National Assembly. After having retired with the rank of lieutenant colonel, He was brought to Topkapı Palace Library Management as the manager. He died in 1925 in İstanbul. He has got 25 masterpieces and the most famous masterpiece of him, "Osmanlı Müellifleri (Ottoman Authors)", has still been used at the Harvard University as one of the sources. He paid attention to the usage of maps in Geography courses. So, he brought French atlases to his classrooms. He was against rote learning in History and Geography courses. He used to teach a country's borders, regime and population first. He made his students draw the map first and he used to talk about old and existing relationships between countries then. He accepted Geography as the basis of the History. In his History courses, he requested his students to write some extra questions and give him back. By means of this he made himself become eager to search. He was in favor of the renewal and the purification of the language. In his Literature courses, he used to explain the terminologies first and then used to broaden all. He used to examine the text which was written by his students and ask for corrections according to the spelling rules. Then he himself used to do the corrections by looking at the papers. He was against rote learning (memorization), but he used to ask his students to memorize moral and national poems as well as proverbs. Mehmet Tahir was one of the founders Thessaloniki Department of the Motherland and Liberty Association which is secretly founded by Mustafa Kemal. Mustafa Kemal paid 500 Liras and bought some parts of Mehmet Tahir's books called "Ottoman Authors" and saved from the printing house while Mehmet Tahir was suffering from poverty in his last years, Mehmet Tahir's tombstone was built in 1935 by Atatürk.

Key Words : Mehmed Tahir from Bursa, Mustafa Kemal Atatürk, Ottoman Authors (OM)

His Life

Mr. Mehmet Tahir's father is called Mr. Rifat and his mother, whose name was Mrs. Rahime, was the daughter of Sir Necip from Bursa. Mehmet Tahir was born in Yerkapı district in Bursa on a Friday night on the 22nd of November, 1861(Akçura,1981&Vahyi,1335).

He started his education at Yerkapı school, which was located opposite to their house. Then he enrolled in the Military Middle School. While he was studying at the Military Middle School, he also had some religion courses from Harraçoğlu Moslem Theological School and learnt Arabic. After completing the Middle School as the top student, he started studying at the Military High School. He finished that school as the top student once again and joined the Army Military Academy (the Military of Affairs). Then finally, he graduated from the Army Military Academy as an infantry lieutenant(Aksüt,1944&Vahyi1335&Mehmed Fuad,1329)

He started his teaching life as a geography teacher in Bitola. He gave lectures on history and oratory in the Military Middle School and the Military High School(Akün,1992). He worked as a director at the Salonika Military Middle School. By that time, he was promoted to a major commander. However, he was suspended from his duty at the Salonika Military Middle School as a manager due to the reports published about him(Kepecioğlu,nr.4519).

Mehmet Tahir was among one the founders of the Ottoman Liberty Association, which was founded in Salonika in 1906. His rank was the highest so that he was at the top among the members(Tunaya,1984&Unat,1960). We also know that he was a member of the Motherland and Liberty Association when Mustafa Kemal founded it in Salonika in 1906(Ülken,1992). Afterwards, Ottoman Liberty Association joined the Young Turks in Europe and renamed itself as the Ottoman Committee of Union and Progress. In that era, Mr. Tahir raised to the rank of

sheikh in the Malāmatiyya(Gölpınarlı,1992&Kara1992). He gained a strong political personality. Mehmet Tahir's power is such increased that the third President Celal Bayar registered to the Ottoman Committee of Union just because of the encouragements of him.

Mr. Tahir had always seen himself not only a politician but also a scientist, he became a deputy from Bursa after the declaration of the Second Constitutional Era. Just before the Assembly opened, he had temporarily been elected as the chief(Kutay,1961&Bayur,1952).

He took active roles in Chamber of Deputies that was created in 17th of December, 1908. He was nominated to give lectures to tell people about the goals of constitutionalism. He resigned being a deputy after the first part of Chamber of Deputies that ended at the end of 1911(Kabasakal,1981).

His ministration in Salonika Military Middle School Management was dismissed because of politic reasons. His degree was squadron leader when he was a deputy(Bleda,1979).

Then he served in court martial membership and verification officialism in İzmir. Tahir Bey had a big group of friends wherever he went and he wasn't expelled anywhere far because of these faithful friends of him. When he was a member of court martial for the second time, he was retired of being a lieutenant colonel. He was commissioned to research the libraries of İstanbul just before his retirement. During his duty, he investigated lots of manuscript and he made reports for every single library. After 1,5 years of this duty, he became the manager of Topkapı Palace Library(Akün,1992&Vahyi1335&Türk ve Dünya Ünlüleri Ansiklopedisi1983).

When Tahir Bey was on his duty in Alaşehir, his family came to İstanbul and rented a house. Following days brought his family financial difficulties. Ultimately, Tahir Bey borrowed a big amount of Money from government lending agency. He was unfortunately at the top of the list when the government lending agency announced the names of the debtors. Yet he still didn't change his principle of inviting his guests to his house every week.

His health problems were one of the problems that he had to deal with except for his financial difficulties. "Oymacılık ve Bursalı Oymacı Fahri" was one of his last scripts. While second and third volumes of "Osmanlı Müellifleri" was being pressed, Tahir Bey was sick. He wrote a letter to his friend Mehmet Ali Avni and told about his worries and asked for help. Mehmet Ali Avni provided the Money that he needed and got books from press. Mustafa Kemal bought some of the books for 500 liras in cash against goods(Aksüt,1944&Ergin,1937&).

In his last times, it has been detected that Tahir Bey had underdeveloped intelligence and he died in 28th of October, 1925 in Zeynep Kamil Hospital. The following day, he was buried in Aziz Mahmud Hüdayi islamic monastery. It was rueful that his death wasn't announced by any newspaper except for Cumhuriyet(Akün,1992).

Scientific Methods

His Researcher Characteristics

His father and then Haririzade effected scientific activities of Tahir Bey(Gölpınarlı,1992). He researched sufis that lived in Bitola, poets and scientists and investigated gravestones. He asked for information by letter many times. His first literary work "Türklerin Ulum ve Fünuna Hizmetleri" was published in 1897. He used to consider important to outstanding people(Bursalı Mehmed Tahir 1327).

He published his writings in some journals like Sırat-ı Müstakim, Sebilürreşad and Türk Yurdu. Most of his writings were about bibliography. Around same period, he published the second volume of "Osmanlı Müellifleri"(Bursalı Mehmed Tahir1975) . Tahir Bey is the second most-known bibliography and biography investigator of the last period of the Ottoman Empire after Mehmet Süreyya Bey.

Tahir Bey thought bibliography and biography complete each other. He believed that bibliography is a science that shows cultural level of a society(Bursalı Mehmed Tahir,1325). He travelled to the libraries of Bitola, Kosovo, Salonica, Aydın, İzmir, Manisa, Konya, Bursa and İstanbul. He dedicated his life to remind writers who were forgotten. In the period that he lived, he was honored to be paraised as "the best book introduction scientist of Turks", "the only book introduction expert". He played an important role of opening "İshakiye Library" in Bitola, "Ulucami Library" in Bursa and "Aziz Mahmud Hüdayi İslamic Monastery Library" in Üsküdar(Beyatlı,1973).

The Importance of Sufism in His Scientific Life

Mr. Rifat, who was a member of naqshbandi tariqa, had a major role in his personal development. Because of the religious conversations that were done during his childhood at his home, he inclined to sufism and got a crush on Muhyiddin İbnü'l-Arabi. When he was a student at the military college, Haririzade who was the writer of Tıbyanü Vesaili'l Hakaik became his mentor. When Haririzade passed away, he obeyed Muhammed Nuru'l-Arabi. When he was at monastery, he arranged religious conversations at Friday nights. During the death of his Sheikh, he had become one of the well-known figures of Melamilik tariqa in this region. He concentrated on scientific activities in time and this situation hindered his religious conversations(Gölpınarlı,1992&Hasan Taib Efendi,1323&Gövsa,tarihsiz).

The Methods That He Used In Teaching

Although Geography was generally taught through memorization at that time, Mr. Tahir made it interesting with the methods that he followed. He gave great importance to the map that comprised a basis for Geography and every kind of Geographic information. He made his students bring a lot of French atlas to the class and provided a basis for the students to make use of them(Vahyi,1335).

Mr. Tahir strongly objected to having students memorize book sentences. In his opinion, teaching Geography and History wasn't composed of making students memorize information and making their memory into an index which includes the names of cities, rivers, mountains and gulfs. He didn't want all of the cities in the book. Furthermore, he found it unnecessary to learn the population of the cities that he wanted. First, he taught the borders of a state, its regime and general population. Especially at that time, it was enough to tell the strength that he had with a nice map. Also, with the help of the map, it was enough to tell under what reasons the strength formed. However, having a student draw the map on the board wasn't enough for him. He told the old and new relationships of the states that he analyzed with other states. He accepted Geography as the basis of History. This Geography and History teacher who dedicated himself to such a conscientious duty didn't confine himself to the new Geography and History. He was in intense research activities in order to know the old History and Geography of Turks and to compare them with the new ones.

When he had extra time in history lessons, he accepted his students' questions in a written form. For the questions that he couldn't answer at that time, he carried out a method in order to make a research about the questions and answer them. This method was suitable in order to give students a sense of curiosity and force himself to non-stop researches(Vahyi,1335&Develioğlu1988).

Mr.Tahir supported innovation and simplification of Turkish. He had some desires:

He wanted his book that is written in Istanbul to be read in Kashgar. Turkish should experience improvement within its own nature. Our literature should be based on logical, scientific and professional principles. Also, our literature should show the lives of Anatolian people. A Turkish person who has some education should find consolation in literature wherever s/he is(Tanpınar,1988).

Within the frame of new methods that he followed in literature lessons, he explained the concept that he taught and developed it with questions. Then, he analyzed the answers of the students one by one. When he noticed spelling and grammar mistakes, he crossed them out with a red pen and gave them back to his students. Therefore, he forced his students to correct their mistakes. Then, Mr. Tahir made the necessary corrections on the 2nd papers that his students gave. In this way, not only the teacher, but also the students made an effort in one method. As mentioned earlier, Mr. Tahir didn't support memorization. However, he made his students memorize poems that are about moral and the country. Especially, he made them memorize the proverbs(Vahyi,1335).

REFERENCES

- Akçura, Y. (1981). *Yeni Türk devleti'nin öncüleri*. Ankara: Kültür Bakanlığı Yayınları.
Aksüt, A. K. (1944). *Mehmet Ali Ayni hayatı ve eserleri*. İstanbul: Ahmet Sait Matbaası.
Akün, Ö. F. (1992). *Bursalı Mehmet Tahir*. Türkiye Diyanet Vakfı İslam Ansiklopedisi, 6, 452-461.
Babinger, F. (1992). *Osmanlı tarih yazarları ve eserleri*. Çev. Coşkun Üçok, Ankara: Kültür Bakanlığı Yayını.
Bayur, Y. K. (1952). *Türk inkılab tarihi*, Cilt II, Kısım IV, Ankara: TTK Basımevi.
Beyatlı, Y. K. (1973). *Çocukluğum, gençliğim, siyasi ve edebi hatıralarım*. İstanbul: Baha Matbaası.
Bleda, M. S. (1979). *İmparatorluğun çöküşü*. İstanbul: Remzi Kitabevi Yay.
Bursalı Mehmed Tahir (1325). *"İlm-i ahval-i kütüb-bibliyografı"*. Hüdavendigâr Gazetesi, Nüsha-i Mahsusa.

- Bursalı Mehmed Tahir. *Osmanlı müellifleri*. Cilt I, İstanbul: Meral Yayınevi.
- Bursalı Mehmed Tahir (1972). *Osmanlı müellifleri*. Cilt II, Meral Yayınevi.
- Bursalı Mehmed Tahir (1975). *Osmanlı müellifleri*. Cilt III, Meral Yayınevi.
- Bursalı Mehmed Tahir (1327). *Türklerin ulum ve fünuna hizmetleri*. İstanbul: Necm-i İstikbal Matbaası, 2.baskı.
- Cumhuriyet Dönemi Türkiye Ansiklopedisi*. Cilt VIII, İstanbul: İletişim Yay.
- Develioğlu, F. (1988). *Osmanlıca-Türkçe ansiklopedik lugat*. Ankara: Aydın Kitabevi yay.
- Ergin, O. N. (1937). *Muallim M. Cevdet'in hayatı, eserleri kütüphanesi*. İstanbul: İstanbul Basımevi.
- Gölpınarlı, A. (1992). *Melamilik ve melamiler*. İstanbul: Gri yayın.
- Gövsa, İ. A. *Türk meşhurları ansiklopedisi*, Yedigün Neşriyat.
- Hasan Taib Efendi (1323). *Hatıra Yahud Mirat-ı Bursa*. Bursa: Hüdavendigâr Vilayeti Matbaası.
- Kabasakal, M. (1991). *Türkiye'de siyasal parti örgütlenmesi 1908-1960*. İstanbul: Tekin Yayınevi.
- Kara, M. (1992). *Tasavvuf ve tarikatler*. İstanbul: İletişim yay.
- Kepecioğlu, K. Bursa Kütüğü, Cilt IV, Bursa Eski Yazma ve Basma Eserler Ktp., Genel bl., nr. 4519.
- Köprülüzade M. F. (1329). Bursalı Tahir Bey. *Türk Yurdu*, 1(20),768-770.
- Kutay, C. (1961). *Türkiye istiklal ve hürriyet müc. tarihi*. Cilt XV. İstanbul: Nurgök Matbaası.
- Muallim Vahyi (1335). *Müslümanlık ve Türklüğü yüceltmeye çalışanlardan: Bursalı Tahir Bey*. İstanbul: Orhaniye Matbaası.
- Tanpınar, A. H. (1988). *19. asır Türk edebiyatı tarihi*. İstanbul: Çağlayan Kitabevi.
- Tunaya, T. Z. (1984). *Türkiye'de siyasal partiler*. Cilt I, II. Meşrutiyet Dönemi (1908-1918). İstanbul: Hürriyet Vakfı Yay.
- Türk ve Dünya Ünlüleri Ansiklopedisi* (1983). Cilt III, Anadolu Yayıncılık.
- Türk Dili ve Edebiyatı Ansiklopedisi* (1990). Cilt VII, İstanbul Dergah Yay.
- Unat, F. R. (1960). *II. meşrutiyetin ilanı ve 31 Mart hadisesi. II. Abdülhamid'in son mabeyn başkatibi Ali Cevat Bey'in fezlekesi*. Ankara: TTK Basımevi.
- Ülken, H. Z. (1992). *Türkiye'de çağdaş düşünce tarihi*. İstanbul: Ülken Yay.

ÖĞRENME STİLLERİ, MATEMATİK KAYGISI, MATEMATİK ÇALIŞMA SÜRESİ VE MATEMATİK BAŞARISI ARASINDAKİ AÇIKLAYICI VE YORDAYICI İLİŞKİLER

EXPLANATORY AND PREDICTIVE PATTERN OF LEARNING STYLES, MATH ANXIETY, MATH STUDY TIME AND MATHEMATICS ACHIEVEMENT

Eyüp YURT
Necmettin Erbakan Üniversitesi
eyupyurt@gmail.com

Ali Murat SÜN BÜL
Necmettin Erbakan Üniversitesi
asunbul@konya.edu.tr

ÖZET: Bu araştırmanın amacı ortaokul öğrencilerinin öğrenme stilleri, matematik kaygıları, ders çalışma süreleri ve matematik başarıları arasındaki ilişkileri incelemektir. Tarama modeli ile gerçekleştirilen araştırmaya 396 ortaokul öğrencisi katılmıştır. Çalışma grubunun %60'ını kız (n=238), %40'ını erkek (n=158) öğrenciler; %42'sini (n=166) 6. sınıf, %32'sini (n=127) 7. sınıf ve %26'sını (n=111) 8. sınıf öğrencileri oluşturmuştur. Öğrencilerin matematik kaygılarını belirlemek için Matematik Kaygı Ölçeği, öğrenme stillerini belirlemek için Öğrenme Stilleri Envanteri ve ders çalışma sürelerini belirlemek için bilgi formu kullanılmıştır. Öğrencilerin matematik başarılarını belirlemek için ise matematik dersi yılsonu not ortalaması dikkate alınmıştır. Çalışmanın amacı doğrultusunda toplanan veriler, Yapısal Eşitlik Modeli ile analiz edilmiştir. Elde edilen sonuçlara göre, matematik kaygısı, ders çalışma süresi ($r=-.17$, $p<.001$) ve öğrenme stilleri ($r=-.42$, $p<.001$) ile negatif yönlü ve anlamlı ilişkilere sahiptir. Diğer yandan, öğrenme stilleri ve ders çalışma süresi arasında ise pozitif yönlü ve anlamlı bir ilişki ($r=.33$, $p<.001$) bulunmaktadır. Ayrıca matematik kaygısının matematik başarıları üzerinde negatif yönlü ve anlamlı ($\beta=-.47$, $p<.001$) bir etkisi vardır. Ders çalışma süresinin ise matematik başarıları üzerinde pozitif yönlü ve anlamlı ($\beta=.13$, $p<.001$) bir etkisi bulunmaktadır. Elde edilen bulgular doğrultusunda bir takım önerilerde bulunulmuştur.

Anahtar sözcükler: Matematik başarıları, ders çalışma süresi, matematik kaygısı, öğrenme stilleri, yapısal eşitlik modellenmesi

ABSTRACT: The purpose of the study was to investigate relationship between learning style, math anxiety, math study time and mathematic achievement. The study conducted according to correlational survey model, included 396 middle students. The study group consisted of %60 girls (n=238) and %40 boys (n=158); %42 (n=166) 6 grade, %32 (n=127) 7 grade and %26 (n=111) 8 grade students. In the study Math Anxiety Scale was used in determining the students' math anxiety; Learning Styles Inventory was used in determining the students' learning styles and Information Form was used in determining the students' math study time. Also, students' semester grades were considered in determining the students' math achievement. The data collected in the study were analyzed using the Structural Equation Model. According to the results obtained, math anxiety has significant correlation with math study time ($r=-.17$, $p<.001$) and learning style ($r=-.42$, $p<.001$). On the other hand, there was a positive and significant relationship ($r=.33$, $p<.001$) between math study time and learning style. Also, math anxiety has a negative and significant effect ($\beta=-.47$, $p<.001$) on mathematic achievement. Unlike, math study time has a positive and significant effect ($\beta=.13$, $p<.001$) on mathematic achievement. According to findings, some suggestions were given.

Key words: Mathematic achievement, study time, math anxiety, learning style, structural equation modelling

CENTRAL HOSPITAL APPOINTMENT SYSTEM (CHAS-MHRS)

WEB SITE'S USABILITY

Alaaddin ÖZTÜRK
Necmettin Erbakan University
mervaleozturk@gmail.com

Şemseddin GÜNDÜZ
Necmettin Erbakan University
semsedding@gmail.com

ABSTRACT: Central Hospital Appointment System; is an application (<http://www.mhrs.gov.tr>) that people can take an appointment which they want from state's hospitals, mouth and dental health center and family doctors via central hospital appointment system. This implementation's main purpose is to give more efficient on medical service. The aim of this study is to determine usability levels of this website. The research was carried out of twelve people. Firstly four duties are specified (join, get an appointment, cancel an appointment and changing password) and then users are wanted to do these duties. While they're obeying their duties, (their ability to obey rules, occupancy and difficulties) data were collected with observation and interview. Two of the users could not join the website, other three fulfilled giving duties hardly. This implementation should be brought practical situation for disabled people.

Key words: usability, website, mhrs, hospital appointment

ON COMPLETION IN PSEUDO-QUASI-N-NORMED SPACE

Elida HOXHA
University of Tirana, Tirana, Albania
elida.hoxha@fshn.edu.al

Silvana LIFTAJ
University of A. Moisiu, Durrës, Albania
silvanaliftaj@yahoo.com

ABSTRACT: The concept of 2-metric spaces and 2-normed spaces were initially introduced by Gahler S., in 1960's. Since 1963, S. Gahler, Y. J. Cho, R. W. Freese, C. R. Diminnier, R. E. Ehret, K. Iséki, A. White and many others have studied on 2-normed spaces, 2-metric spaces, and on n-normed spaces. It is well-know that R is complete, but Q is not complete, Since Q is dense in R is said that R is completion of Q. It is very important that an incomplete space can be completed in similar sense. Complete spaces, in other words Banach spaces, play quite important role in many branches. Park C. has investigate the completion of generalized quasi-normed spaces. In this paper we treated the completion of pseudo-quasi-n-normed spaces. Our result generalized the results of M. Kir and M. Acikgoz, which solved the problem of completion quasi-2-normed space.

Key words: 2-normed spaces, pseudo-quasi-n-normed space, n-normed space, completion

INTRODUCTION

The concept of 2-metric spaces and 2-normed spaces were initially introduced by Gahler S [2], [3] in 1960's. Since 1963, S. Gahler, Y. J. Cho, R. W. Freese, C. R. Diminnier, R. E. Ehret, K. Iséki, A. White and many others have studied on 2-normed spaces, 2-metric spaces, and on n-normed spaces [5], [6]. As well as 2-normed spaces a special interest has been also study of n-normed spaces and their completeness. Complete spaces, in other words Banach spaces, play quite important role in many branches. It is known the fact that R is a complete space, but Q is not. Since Q is everywhere dense in R, we call R completion of Q. It is very important that an incomplete space can be completed in similar sense. Choonkil Park [4] has investigated the completion of the generalized quasi-normed space, which left the problem for construction of completion of a quasi-2-normed space. Mehmet Kir and Mehmet Acikgoz [1] have found the answer for the Park's problem. Starting by this, we have studied compeltion of pseudo-quasi-n-normed spaces.

Definition 1.1. [4] Let $n \in \mathbb{N}$ (natural numbers) and E be a vector space of dimension $d \geq n$. (Here we allow d to be infinite). A n -norm on E is a real valued function $\| \bullet, \dots, \bullet \| : E^n \rightarrow [0, +\infty[$, which satisfies the following four conditions:

- 1) $\| x_1, x_2, \dots, x_n \| = 0$ if and only if when x_1, x_2, \dots, x_n are linearly dependent,
- 2) $\| x_1, x_2, \dots, x_n \|$ is invariant under permutation,
- 3) $\| x_1, x_2, \dots, x_{n-1}, \alpha x_n \| = |\alpha| \| x_1, x_2, \dots, x_{n-1}, x_n \| \forall \alpha \in \mathbb{R}, (x_1, x_2, \dots, x_n) \in E^n$,
- 4) $\| x_1, x_2, \dots, x_{n-1}, y + z \| \leq \| x_1, x_2, \dots, x_{n-1}, y \| + \| x_1, x_2, \dots, x_{n-1}, z \|$,
 $\forall x_1, x_2, \dots, x_{n-1}, y, z \in E$,

The pair $(E, \| \bullet, \dots, \bullet \|)$ is then called a n -normed space.

Example 1.1. Let $E = \mathbb{R}^n$ we define $\| x_1, x_2, \dots, x_n \| = |\det(x_{ij})|$,

$$\text{where } (x_{ij}) = \begin{pmatrix} x_{11} & \dots & x_{1j} & \dots & x_{1n} \\ \dots & \dots & \dots & \dots & \dots \\ x_{i1} & \dots & x_{ij} & \dots & x_{in} \\ \dots & \dots & \dots & \dots & \dots \\ x_{n1} & \dots & x_{nj} & \dots & x_{nn} \end{pmatrix}, x_j = \begin{pmatrix} x_{1j} \\ \dots \\ x_{ij} \\ \dots \\ x_{nj} \end{pmatrix} \text{ for } 1 \leq i \leq n, 1 \leq j \leq n.$$

Definition 1.2. Let $n \in \mathbb{N}$ (natural numbers) and E be a vector space of dimension $d \geq n$. A quasi- n -norm on E is a real valued function $\| \bullet, \dots, \bullet \| : E^n \rightarrow [0, +\infty[$, which satisfies the following four conditions:

- 1) $\| x_1, x_2, \dots, x_n \| = 0$ if and only if when x_1, x_2, \dots, x_n are linearly dependent,
- 2) $\| x_1, x_2, \dots, x_n \|$ is invariant under permutation,
- 3) $\| x_1, x_2, \dots, x_{n-1}, \alpha x_n \| = |\alpha| \| x_1, x_2, \dots, x_{n-1}, x_n \| \forall \alpha \in \mathbb{R}, (x_1, x_2, \dots, x_n) \in E^n$,
- 4) $\exists c \geq 1, \| x_1, x_2, \dots, x_{n-1}, y + z \| \leq c [\| x_1, x_2, \dots, x_{n-1}, y \| + \| x_1, x_2, \dots, x_{n-1}, z \|]$,

$\forall x_1, x_2, \dots, x_{n-1}, y, z \in E$,
The pair $(E, \|\bullet, \dots, \bullet\|)$ is then called a quasi- n -normed space.

Example 1.2. Let E be a linear space of dimension $d \geq n$ and $\|\bullet, \dots, \bullet\|$ a n -norm on E . The function $\|\bullet, \dots, \bullet\|_q : E^n \rightarrow \mathbb{R}^+$, which

$$\|x_1, x_2, \dots, x_n\|_q = c \|x_1, x_2, \dots, x_n\|, \text{ where } c > 1,$$

is a quasi- n -norm. It is evident.

Definition 1.3. Let $n \in \mathbb{N}$ (natural numbers) and E be a vector space of dimension $d \geq n$. A pseudo-quasi- n -norm on E is a real valued function $\|\bullet, \dots, \bullet\| : E^n \rightarrow [0, +\infty[$, which satisfies the following four conditions:

- 1) If x_1, x_2, \dots, x_n are linearly dependent, then $\|x_1, x_2, \dots, x_n\| = 0$,
- 2) $\|x_1, x_2, \dots, x_n\|$ is invariant under permutation,
- 3) $\|x_1, x_2, \dots, x_{n-1}, \alpha x_n\| = |\alpha| \|x_1, x_2, \dots, x_{n-1}, x_n\| \forall \alpha \in \mathbb{R}, (x_1, x_2, \dots, x_n) \in E^n$,
- 4) $\|x_1, x_2, \dots, x_{n-1}, y + z\| \leq c [\|x_1, x_2, \dots, x_{n-1}, y\| + \|x_1, x_2, \dots, x_{n-1}, z\|]$,
where $c \geq 1, \forall x_1, x_2, \dots, x_{n-1}, y, z \in E$,

The pair $(E, \|\bullet, \dots, \bullet\|)$ is then called a pseudo-quasi- n -normed space.

Definition 1.4. Let $(E, \|\bullet, \dots, \bullet\|)$ be a vector pseudo-quasi- n -normed space.

- a) The sequence $\{x_n\}_{n \in \mathbb{N}}$ is called Cauchy sequence if $\lim_{k,l \rightarrow \infty} \|x_1, x_2, \dots, x_{n-1}, x_k - x_l\| = 0$, for all $x_1, x_2, \dots, x_{n-1} \in E$,
- b) The sequence $\{x_n\}_{n \in \mathbb{N}}$ is called convergence in x if $\lim_{k \rightarrow \infty} \|x_1, x_2, \dots, x_{n-1}, x_k - x\| = 0$, for all $x_1, x_2, \dots, x_{n-1} \in E$,
- c) The pseudo-quasi- n -normed space $(E, \|\bullet, \dots, \bullet\|)$ is called complete when every Cauchy sequence converges in a point of E .

Definition 1.5. The pseudo-quasi- n -norm function in E , is called uniformly continuous if $\forall \varepsilon > 0, \exists$ neighborhood of 0 in E, μ_ε , such that for $x_1 - x'_1, x_2 - x'_2, \dots, x_n - x'_n \in \mu_\varepsilon$:

$$\| \|x_1, x_2, \dots, x_n\| - \|x'_1, x'_2, \dots, x'_n\| \| < \varepsilon.$$

Definition 1.6. Let $(X, \|\bullet, \dots, \bullet\|_X)$ and $(Y, \|\bullet, \dots, \bullet\|_Y)$ be two pseudo-quasi- n -normed space and $T : X \rightarrow Y$.

- a) The function T is called isometry if for every $(x_1, x_2, \dots, x_n) \in X^n$ is true

$$\|Tx_1, Tx_2, \dots, Tx_n\|_Y = \|x_1, x_2, \dots, x_n\|_X,$$

- b) The space X is called isometric with space Y if exists an isometry of X into Y .

In M. Kir and M. Acikgoz [1] have proved completeness of quasi-2-normed spaces. In this paper we will extend this result of M. Kir and M. Acikgoz and we will show completeness of pseudo-quasi- n -normed spaces.

RESULTS AND FINDINGS

Let $(E, \|\bullet, \dots, \bullet\|)$ be a pseudo-quasi- n -normed space with uniformly continuous pseudo-quasi- n -norme.

Definition 2.1. The Cauchy sequences $(x_k)_{k \in \mathbb{N}}$ and $(y_k)_{k \in \mathbb{N}}$ are called equivalent if

$$\lim_{k \rightarrow \infty} \|a_1, a_2, \dots, a_{n-1}, x_k - y_k\| = 0, \text{ for all } a_1, a_2, \dots, a_{n-1} \in E.$$

We denote this $(x_k)_{k \in \mathbb{N}} \sim (y_k)_{k \in \mathbb{N}}$.

Theorem 2.1. The relation “ \sim ” in set of Cauchy sequences in E is equivalence relation.

Proof.

- 1) $(x_k) \sim (x_k) \Rightarrow \forall a_1, a_2, \dots, a_{n-1} \in E$ we have that $a_1, a_2, \dots, a_{n-1}, x_k - x_k$ is linearly dependent, then $\|a_1, a_2, \dots, a_{n-1}, x_k - x_k\| = 0$.

$$\begin{aligned} 2) (x_k) \sim (y_k) \text{ we have } \lim_{k \rightarrow \infty} \|a_1, a_2, \dots, a_{n-1}, x_k - y_k\| &= \lim_{k \rightarrow \infty} \|a_1, a_2, \dots, a_{n-1}, -(y_k - x_k)\| = \\ &= \lim_{k \rightarrow \infty} |-1| \|a_1, a_2, \dots, a_{n-1}, y_k - x_k\| = \lim_{k \rightarrow \infty} \|a_1, a_2, \dots, a_{n-1}, y_k - x_k\| = 0, \text{ then } (y_k) \sim (x_k). \end{aligned}$$

- 3) $(x_k) \sim (y_k)$ and $(y_k) \sim (z_k)$ we have

$$\begin{aligned} \|a_1, a_2, \dots, a_{n-1}, x_k - z_k\| &= \|a_1, a_2, \dots, a_{n-1}, (x_k - y_k) + (y_k - z_k)\| \leq \\ &\leq c [\|a_1, a_2, \dots, a_{n-1}, x_k - y_k\| + \|a_1, a_2, \dots, a_{n-1}, y_k - z_k\|]. \end{aligned}$$

Passing to the limit as k goes to infinity, we get

$$\lim_{k \rightarrow \infty} \|a_1, a_2, \dots, a_{n-1}, x_k - z_k\| = 0 \Rightarrow (x_k) \sim (z_k).$$

Theorem 2.2. If sequences $(x_k)_{k \in \mathbb{N}}$ and $(y_k)_{k \in \mathbb{N}}$ are equivalent with $(x'_k)_{k \in \mathbb{N}}$ and $(y'_k)_{k \in \mathbb{N}}$, respectively, then $(x_k + y_k)_{k \in \mathbb{N}}$ and $(x'_k + y'_k)_{k \in \mathbb{N}}$, are equivalent too and for every $\alpha \in \mathbb{R}$ the sequence $(\alpha x_k)_{k \in \mathbb{N}}$ is equivalent with $(\alpha x'_k)_{k \in \mathbb{N}}$.

Proof. For all $a_1, a_2, \dots, a_{n-1} \in E$ we have

$$\begin{aligned} \|a_1, a_2, \dots, a_{n-1}, (x_k + y_k) - (x'_k + y'_k)\| &= \|a_1, a_2, \dots, a_{n-1}, (x_k - x'_k) + (y_k - y'_k)\| \leq \\ &\leq c[\|a_1, a_2, \dots, a_{n-1}, x_k - x'_k\| + \|a_1, a_2, \dots, a_{n-1}, y_k - y'_k\|] \end{aligned}$$

Passing to the limit as k goes to infinity in inequality

$$\|a_1, a_2, \dots, a_{n-1}, (x_k + y_k) - (x'_k + y'_k)\| \leq c[\|a_1, a_2, \dots, a_{n-1}, x_k - x'_k\| + \|a_1, a_2, \dots, a_{n-1}, y_k - y'_k\|],$$

we get

$$\lim_{k \rightarrow \infty} \|a_1, a_2, \dots, a_{n-1}, (x_k + y_k) - (x'_k + y'_k)\| = 0.$$

Thus $(x_k + y_k)_{k \in \mathbb{N}} \sim (x'_k + y'_k)_{k \in \mathbb{N}}$. So, the property

$$\|a_1, a_2, \dots, a_{n-1}, \alpha x_k - \alpha x'_k\| = |\alpha| \|a_1, a_2, \dots, a_{n-1}, x_k - x'_k\|$$

imply, for k goes to infinity, $(\alpha x_k) \sim (\alpha x'_k)$.

Let denote by

- \hat{x}, \hat{y}, \dots the equivalence classes of Cauchy sequences $(x_k), (y_k)$ in E and by \hat{E} the set of the equivalence classes.
- $\hat{x} + \hat{y}$ the set of Cauchy sequences equivalent with $(x_k + y_k)_{k \in \mathbb{N}}$, where $(x_k)_{k \in \mathbb{N}} \in \hat{x}, (y_k)_{k \in \mathbb{N}} \in \hat{y}$,
- $\alpha \hat{x}$ the set of Cauchy sequences equivalent with $(\alpha x_k)_{k \in \mathbb{N}}$, where $(x_k)_{k \in \mathbb{N}} \in \hat{x}$.

Theorem 2.3. If E is equipped with a pseudo-quasi- n -norm uniformly continuous, then for every n Cauchy sequences $(x_k^{(i)})_{k \in \mathbb{N}}$, for $i = 1, \dots, n$, exist the $\lim_{k \rightarrow \infty} \|x_k^{(1)}, x_k^{(2)}, \dots, x_k^{(n)}\|$.

Proof. Let $(x_k^{(i)})_{k \in \mathbb{N}}$, for $i = 1, \dots, n$, be Cauchy sequences and $\varepsilon > 0$. From uniformly continuous of pseudo-quasi- n -norm function, exist neighborhood of 0, μ , such that for points $(x_k^{(i)})_{i=1}^n$ and $(x_l^{(i)})_{i=1}^n$, where $x_k^{(i)} - x_l^{(i)} \in \mu$, for all $i=1, \dots, n$. and $k, l > N(\varepsilon)$, we have

$$\| \|x_k^{(1)}, x_k^{(2)}, \dots, x_k^{(n)}\| - \|x_l^{(1)}, x_l^{(2)}, \dots, x_l^{(n)}\| < \varepsilon.$$

This shows that the sequence $(\|x_k^{(1)}, x_k^{(2)}, \dots, x_k^{(n)}\|)_{k \in \mathbb{N}}$ is Cauchy in \mathbb{R} , and consequently, this sequence is convergent.

Theorem 2.4. If vector space E is equipped with a pseudo-quasi- n -norm uniformly continuous, then for sequences $(x_k) \sim (x'_k)$ and $(y_k) \sim (y'_k)$, we have

$$\lim_{k \rightarrow \infty} \|a_1, a_2, \dots, a_{n-2}, x_k, y_k\| = \lim_{k \rightarrow \infty} \|a_1, a_2, \dots, a_{n-2}, x'_k, y'_k\|,$$

for every $a_1, a_2, \dots, a_{n-2} \in E$.

Proof. The proof of the theorem is based on Theorem 2.3.

The theorem is valid and for i Cauchy sequences, where $i = 1, \dots, n$.

Corollary 2.5. If sequences $(x_k^{(i)}), (y_k^{(i)})$ are equivalent, for $i = 1, \dots, n$, then

$$\lim_{k \rightarrow \infty} \|x_k^{(1)}, x_k^{(2)}, \dots, x_k^{(i)}\| = \lim_{k \rightarrow \infty} \|y_k^{(1)}, y_k^{(2)}, \dots, y_k^{(i)}\|.$$

Let define in \hat{E}^n the function $\|\bullet, \dots, \bullet\|_1 : \hat{E}^n \rightarrow \mathbb{R}^+$ such that

$$\|\hat{x}_1, \hat{x}_2, \dots, \hat{x}_n\|_1 = \lim_{k \rightarrow \infty} \|x_k^{(1)}, x_k^{(2)}, \dots, x_k^{(n)}\|$$

where $x_k^{(1)} \in \hat{x}_1, x_k^{(2)} \in \hat{x}_2, \dots, x_k^{(n)} \in \hat{x}_n$.

From theorems 2.3 and 2.4, this function is well defined and is independent from choice of representatives $x_k^{(1)}, x_k^{(2)}, \dots, x_k^{(n)}$ from their equivalence classes $\hat{x}_1, \hat{x}_2, \dots, \hat{x}_n$.

Theorem 2.6. The function $\|\bullet, \dots, \bullet\|_1 : \hat{E}^n \rightarrow \mathbb{R}^+$ such that

$$\|\hat{x}_1, \hat{x}_2, \dots, \hat{x}_n\|_1 = \lim_{k \rightarrow \infty} \|x_k^{(1)}, x_k^{(2)}, \dots, x_k^{(n)}\|$$

where $(x_k^{(1)}) \in \hat{x}_1, (x_k^{(2)}) \in \hat{x}_2, \dots, (x_k^{(n)}) \in \hat{x}_n$, is a pseudo-quasi- n -norm in \hat{E} .

Proof. 1) If $\hat{x}_1, \hat{x}_2, \dots, \hat{x}_n$ are linearly dependent, we have $\hat{x}_n = \alpha_1 \hat{x}_1 + \alpha_2 \hat{x}_2 + \dots + \alpha_{n-1} \hat{x}_{n-1}$ and

$$\begin{aligned} \|\hat{x}_1, \hat{x}_2, \dots, \hat{x}_n\|_1 &= \|\hat{x}_1, \hat{x}_2, \dots, \hat{x}_{n-1}, \alpha_1 \hat{x}_1 + \alpha_2 \hat{x}_2 + \dots + \alpha_{n-1} \hat{x}_{n-1}\|_1 = \\ &= \lim_{k \rightarrow \infty} \|x_k^{(1)}, x_k^{(2)}, \dots, x_k^{(n-1)}, \alpha_1 x_k^{(1)} + \alpha_2 x_k^{(2)} + \dots + \alpha_{n-1} x_k^{(n-1)}\| \leq \\ &\leq \lim_{k \rightarrow \infty} c^{n-1} [|\alpha_1| \|x_k^{(1)}, \dots, x_k^{(n-1)}, x_k^{(1)}\| + |\alpha_2| \|x_k^{(1)}, x_k^{(2)}, x_k^{(n-1)}, x_k^{(2)}\| + \dots \\ &\quad + |\alpha_{n-1}| \|x_k^{(1)}, \dots, x_k^{(n-1)}, x_k^{(n-1)}\|] = 0. \end{aligned}$$

2) $\|\hat{x}_1, \dots, \hat{x}_n\|_1 = \lim_{k \rightarrow \infty} \|x_k^{(1)}, \dots, x_k^{(n)}\|$. Since $\|x_k^{(1)}, \dots, x_k^{(n)}\|$ is invariant from permutation of $x_k^{(i)}$, we have $\|\hat{x}_1, \hat{x}_2, \dots, \hat{x}_n\|_1$ is invariant from permutation of \hat{x}_i also.

$$\begin{aligned} 3) \|\hat{x}_1, \hat{x}_2, \dots, \hat{x}_{n-1}, \alpha \hat{x}_n\|_1 &= \lim_{k \rightarrow \infty} \|x_k^{(1)}, \dots, \alpha x_k^{(n)}\| = |\alpha| \lim_{k \rightarrow \infty} \|x_k^{(1)}, \dots, x_k^{(n)}\| = \\ &= |\alpha| \|\hat{x}_1, \hat{x}_2, \dots, \hat{x}_n\|_1 \end{aligned}$$

$$\begin{aligned} 4) \|\hat{x}_1, \hat{x}_2, \dots, \hat{x}_{n-1}, \hat{y}_k + \hat{z}_k\|_1 &= \lim_{k \rightarrow \infty} \|x_k^{(1)}, \dots, x_k^{(n-1)}, y_k^{(n)} + z_k^{(n)}\| \leq \\ &\leq c [\lim_{k \rightarrow \infty} \|x_k^{(1)}, \dots, x_k^{(n-1)}, y_k^{(n)}\| + \lim_{k \rightarrow \infty} \|x_k^{(1)}, \dots, x_k^{(n-1)}, z_k^{(n)}\|] = \\ &= c [\|\hat{x}_1, \hat{x}_2, \dots, \hat{x}_{n-1}, \hat{y}_k\|_1 + \|\hat{x}_1, \hat{x}_2, \dots, \hat{x}_{n-1}, \hat{z}_k\|_1]. \end{aligned}$$

Theorem 2.7. Every vector space E equipped with a pseudo-quasi- n -norm uniformly continuous has its completion.

Proof. As above, we construct the vector pseudo-quasi- n -normed space $(\hat{E}, \|\cdot, \dots, \cdot\|_1)$.

Step 1. Let show that E is isomorphe with a subspace of \hat{E} , dense in \hat{E} . Every constant sequence $x, x, \dots, x, (x_k)_{k \in \mathbb{N}}, x_k = x$, is Cauchy sequence in E , therefore it define an equivalence class in E . Let denote by \tilde{x} its equivalence class. It is evident that $\tilde{x} = \tilde{y} \Leftrightarrow x = y$. Let denote by \hat{E}_0 the set of these equivalence classes and let define the mapping $f: E \rightarrow \hat{E}_0$, such that $f(x) = \tilde{x}$. This function is injective. For every $a_1, a_2, \dots, a_{n-1} \in E$ we have $\tilde{a}_1, \tilde{a}_2, \dots, \tilde{a}_{n-1}$ take part in \hat{E}_0 . So

$$\|\tilde{a}_1, \tilde{a}_2, \dots, \tilde{a}_{n-1}, \tilde{x}\|_1 = \lim_{k \rightarrow \infty} \|a_1, a_2, \dots, a_{n-1}, x\| = \|a_1, a_2, \dots, a_{n-1}, x\|.$$

Thus, f is isometric function and then E and \hat{E}_0 are isometric.

Now, let show that \hat{E}_0 is dense in \hat{E} . Let $\hat{x} \in \hat{E}$ and $(x_k)_{k \in \mathbb{N}}$ a Cauchy sequence representation of \hat{x} . For every k, x_k correspond \tilde{x}_k in \hat{E}_0 , so we have the sequence $(\tilde{x}_k)_{k \in \mathbb{N}}$ in \hat{E}_0 . For every $\tilde{a}_1, \tilde{a}_2, \dots, \tilde{a}_{n-1} \in \hat{E}_0$, we get

$$\|\tilde{a}_1, \tilde{a}_2, \dots, \tilde{a}_{n-1}, \tilde{x}_k - \hat{x}\|_1 = \lim_{k \rightarrow \infty} \|a_1, a_2, \dots, a_{n-1}, x_k - x\| = 0,$$

for $l > k$, since $(x_l)_{l \in \mathbb{N}}$ is Cauchy sequence. Thus

$$\lim_{k \rightarrow \infty} \|a_1, a_2, \dots, a_{n-1}, x_k - x_l\| = 0, \text{ imply } (\tilde{x}_k) \rightarrow \hat{x}, \forall \tilde{a}_1, \tilde{a}_2, \dots, \tilde{a}_{n-1} \in \hat{E}_0.$$

Step 2. Now we will prove that pseudo-quasi- n -normed space $(\hat{E}, \|\cdot, \dots, \cdot\|_1)$ is complete.

For this we must show every Cauchy sequence in \hat{E} converge in \hat{E} . Let $(\hat{x}_m)_{m \in \mathbb{N}}$ be a Cauchy sequence in \hat{E} . Since \hat{E}_0 is dense \hat{E} there is a (\tilde{y}_m) such that for every $\tilde{a}_1, \tilde{a}_2, \dots, \tilde{a}_{n-1} \in \hat{E}_0$ we have

$$\|\tilde{a}_1, \tilde{a}_2, \dots, \tilde{a}_{n-1}, \hat{x}_m - \tilde{y}_m\|_1 < \frac{1}{m}, \forall m \in \mathbb{N}.$$

Also

$$\|\tilde{a}_1, \dots, \tilde{a}_{n-1}, \tilde{y}_m - \tilde{y}_l\|_1 = \|\tilde{a}_1, \dots, \tilde{a}_{n-1}, \tilde{y}_m - \hat{x}_m + \hat{x}_m - \tilde{y}_l\|_1 \leq$$

$$\begin{aligned}
&\leq c[\|\tilde{a}_1, \dots, \tilde{a}_{n-1}, \tilde{y}_m - \hat{x}_m\|_1 + \|\tilde{a}_1, \dots, \tilde{a}_{n-1}, \hat{x}_m - \tilde{y}_l\|_1] \leq \\
&\leq \frac{c}{m} + c\|\tilde{a}_1, \dots, \tilde{a}_{n-1}, \hat{x}_m - \hat{x}_l + \hat{x}_l - \tilde{y}_l\|_1 \leq \\
&\leq \frac{c}{m} + c^2[\|\tilde{a}_1, \dots, \tilde{a}_{n-1}, \hat{x}_m - \hat{x}_l\|_1 + \|\tilde{a}_1, \dots, \tilde{a}_{n-1}, \hat{x}_l - \tilde{y}_l\|_1] \leq \\
&\leq \frac{c}{m} + c^2\|\tilde{a}_1, \dots, \tilde{a}_{n-1}, \hat{x}_m - \hat{x}_l\|_1 + \frac{c^2}{l}.
\end{aligned}$$

Passing to the limit as $m, l \rightarrow \infty$, we get

$$\|\tilde{a}_1, \dots, \tilde{a}_{n-1}, \tilde{y}_m - \tilde{y}_l\|_1 \rightarrow 0.$$

So (\tilde{y}_m) is Cauchy sequence in \tilde{E}_0 . Since \tilde{E}_0 is isomorphic with E , imply $(y_m)_{m \in \mathbb{N}}$ is Cauchy sequence in E .

Let denote by \hat{y} the equivalence class of $(y_m)_{m \in \mathbb{N}}$ and $\lim_{m \rightarrow \infty} \tilde{y}_m = \hat{y}$. We will show $(\hat{x}_m)_{m \in \mathbb{N}}$ converge in \hat{y} .

For every $\hat{a}_1, \dots, \hat{a}_{n-1} \in \hat{E}$ we have

$$\begin{aligned}
\|\hat{a}_1, \dots, \hat{a}_{n-1}, \hat{x}_m - \hat{y}\|_1 &= \|\hat{a}_1, \dots, \hat{a}_{n-1}, \hat{x}_m - \tilde{y}_m + \tilde{y}_m - \hat{y}\|_1 \leq \\
&\leq c[\|\hat{a}_1, \dots, \hat{a}_{n-1}, \hat{x}_m - \tilde{y}_m\|_1 + \|\hat{a}_1, \dots, \hat{a}_{n-1}, \tilde{y}_m - \hat{y}\|_1] \leq \\
&\leq \frac{c}{m} + c\|\hat{a}_1, \dots, \hat{a}_{n-1}, \tilde{y}_m - \hat{y}\|_1
\end{aligned}$$

Since $\lim_{m \rightarrow \infty} \tilde{y}_m = \hat{y}$, passing to the limit as m goes to infinity, in above inequality, we get $(\hat{x}_m) \rightarrow \hat{y} \in \hat{E}$.

So \hat{E} is complete. The space \hat{E} is completion of E .

CONCLUSION

Every vector space E equipped with a pseudo-quasi- n -norm uniformly continuous has its completion.

REFERENCES

1. Kir, M., & Acikgoz, M. (2013). A study involving the completion of quasi-2-normed space. *International Journal of Analysis*, Volume 2013, Article ID 512372, 4 pages
2. Gähler, S. (1963). 2-metrische Räume und topologische structure. *Math. Nachr*, 26, 115 – 148
3. Gähler, S. (1965) Lineare 2-normierte Räume. *Math. Nachr*, 28, 1 – 43
4. Park, Ch. (2006). Generalized quasi-Banach spaces and quasi-(2; p)-normed spaces. *Journal of the Chungcheong Mathematical Society*, Vol. 19, No. 2, 197 – 206
5. Gunawan, H., & Mashadi, M. (2001). On n -normed spaces. *Int. J. Math & Math. Sci.*, 27, No. 10, 631 - 639.
6. Raymond, W. Freese, Y., & Cho, J. (2001). *Geometry of linear 2-normed spaces*. N.Y. Nova Science Publishers. Huntington.

RATES ASSOCIATED PROBLEM-SOLVING ABILITY WITH PROGRAMMING IN COMPUTER STUDENTS

Ali HABIBI

Razi University, Computer Department, Ardebil, Iran
a.habibi.y@gmail.com

Mir Mohammad Reza ALAVI MĪLANĪ

Karadeniz Technical University, Computer Engineering Department, Trabzon, Turkey
milani@ktu.edu.tr

ABSTRACT: In this study, we investigated the relationship between problem-solving ability and scores of programming, in computer students. In order to prove this claim, we design a questionnaire consisting of 15 questions. The gathered answers from student were categorized as “right”, “wrong” and “no responded”. Survey of 100 students of computer in qualitative and quantitative is performed. Also we considered scores of programming course for related students as parameter in evaluation research. for enhance the accuracy of these questionnaires we were interviews with 6 students. The result of this investigation, show that there is Significant relationship between problem-solving ability and programming. Based on the results obtained from this study suggestion were presented to enhance problem-solving ability.

Key words: First-degree equation, Problem-based learning, Computer Algebra System, Problem generator, Problem solver

INTRODUCTION

It is well known that many students have difficulties in programming. Programming is a very complex subject that requires effort and a special approach in the way it is solving and taught. To become a good programmer, a student must acquire a series of abilities that go well beyond knowing the syntax of some programming language and problem solving that problem solving is very significant.

Several approaches have been proposed aiming to learning programming in different ways. Although we find reports of positive results as an outcome of some tools [1], none of them has a general use. In fact, we find reports about the difficulties many students experience when programming.

Result of investigate shows that the problem solving is in the initial phase of programming[2], when students have difficult in understand problem or in problem solving concepts, like to create algorithms that solve concrete problems. Special attention is necessary in this initial stage, not only in the development of programming specific abilities, but also in the improvement and knowledge and abilities that should have been acquired in previous years. Problem solving abilities and logic reasoning is relationship with programming[3-4]. The more traditional view of programming is a mapping of this problem understanding and problem solving onto a programming mechanism [5-6]. However, adopting the “programming as problem solving” perception leads to a programming substrate of a different nature that focuses on facilitating the problem solving process. Before even thinking about what to write in a computer program, the programmer must be sure of what the problem is, precisely. What is the input? What is the output? How should they relate? All your study in computer science will involve work with algorithms and chief notations historically have been pseudo code, flowcharts, and module hierarchy charts which direct relationship with problem solving.

Problem Solving Ability

What is a problem? A problem is a state in which you are trying to reach some goal, and must find a mean for getting there. Each problem has its own solution. Solving problems is a complex cognitive skill that characterizes one of the most intelligent human activities[7]. From childhood onward, we actively solve problems presented to us by the world. We acquire information about the world, and organize this information into structure of knowledge about objects, events, people, and ourselves bodies of understanding, mental models, convictions, and beliefs that influence how we relate our experience life, in school, in our jobs, and at play. How do humans develop their abilities to solve problems in these situations? People differ, children from adults, and experts from novices, and these differences are based on cognitive processes and mental

organizations that humans have in common, and that characterize their problem solving abilities. In this study, we will be evaluated capable of problem solving any students in relation to those of skill in the programming computer[8]. We believe that students have difficult in problem solving, also in computer programming are trouble. Unfortunately, Computer programming has traditionally been taught and practised as a fundamentally individual activity; however, over the last few years, computer science educators have adopted different collaborative learning practices such as programming in pairs and team projects. Through these collaborative activities, students increase their self-confidence, produce better programs and improve their performance and programming skills. But the best way to enhance the programming ability of students is improve their problem-solving ability[9].

The first thing that people are faced is problem. These are generally divide into two categories: With clear solution and no clear solution. Problems with solutions that are commonly present in the technical books and bulletins, or are the problems that people with knowledge of the issue can be solved. This type of solution is shown in Figure 1. Here's a problem to a standard or similar problem is returned. The standard solution of problem is clear and with the solution the problem will be solved.

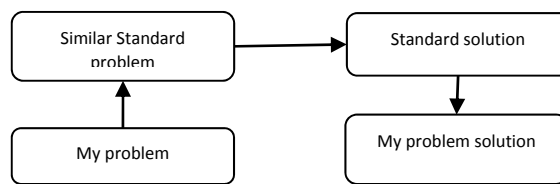

Fig. 1 Clear Solution Type of Problem Solving

Problems which require ideas and innovation are: Other types of problems, problems with uncertain solutions. These types of problems are in need of creativity and innovation. If for problem solving, personal experiences and thoughts of a person who has acquired his expertise to use environment or face defeat, to create new concepts, using alternative technologies, are called "psychological inertia ". To solve these types of problems requires expertise beyond the knowledge of the underlying, individual of creativity and innovation plays a role, too.

METHODS

Research Design

In this study, we investigated the relationship between problem-solving ability and scores of programming, in computer science students. In this research, researchers collected quantitative and qualitative data with questionnaire and interviews of students. The rationale for this approach is that the quantitative data and results provide a table of the research problem; more analysis, specifically through qualitative data collection, is needed to refine, extend, or explain. The quantitative part was conducted in questionnaire design. The treatment variable of the study was Scratch problem solving. The dependent variable of the study was programming skills. The scores of the problem solving and programming skills were gathered through Problem Solving and programming Inventory (PSAPI). In the qualitative part of the research, students were interviews in probelem solving and programming, focus group interview was conducted with students about experimental process problem solving and programming with aexperimental interviews.

Participants

100 high school students, who were attending a computer course in Iran, participated in the study. This computer course is teaching in eight hour per week.

Context and Process

According to the curriculum of the computer programming course in high schools, in many schools, programming environment is being used to teach programming to student.

In this study, we have over students who have a study done 8 hours of lessons per week of programming. In this study, a list of questions prepared in accordance with Table 1. As seen in Table 1 the degree of difficulty was designed with three things. Classification problems in an easy group, including basic information to solve

problems that do not require special or specific innovation. These problems are expected to be resolved correctly by the majority groups. The middlegroup problems, problems they need to solve and simulate the classical method of solving problems is similar to the problems that have clear solutions discussed in the previous section of this article[10]. And Hard problems, involves problems that require individual of creativity and innovation is solving. In the design inquiries and questions are also classified into three distinct groups, from the viewpoints of two computer experts and two teachers were using computers, therefore, the questions of linguistically, levels the content it right credibility.

Table 1. List of Programming Problems

Problem
Quadric Equation solving
Factorial of N
Prime number of less than N
Sum of N number
Average of N number
Recursive function of factorial number N
The greatest common divisor (GCD) of two numbers
Least common multiple (LCM) of two numbers
Find an employee's net salary
Sort of N number
Find of Minimum and Maximum number from N number

Data Analysis

Gender-based research group, and the status of the problem is properly assessed, measured in accordance with Table 2 were designed based on this table were analyzed. Due to the number of students, by sex, frequency of student responses and errors were evaluated.

Table 2. Evaluation criteria in data analysis

Score	criteria
0	Empty (E)
0	Completely Wrong (CW)
1	Partially Correct (PC)
2	Completely Correct (CC)

Also, in order to assess the relationship between problem-solving ability of students with scores programming, we classify programming Course grades in accordance with Table 3.

Table 3. Benchmark score Programming Course categories

Score Range	criteria
0 - 40	Weak (W)
41 - 60	Medium (M)
61- 80	Good (G)
81 - 100	Excellent (E)

RESULTS AND FINDINGS

Data analysis

The data analysis and results are presented with special reference to the research two hypotheses in the problem solving and programming study. Student-based research group, and the status of the problem is properly sessed, measured in accordance with Table 2 were designed based on this table were analyzed. Simple percentages Chi – Square. In compliance with a pre – study of the instrument was carried out and tested with Cronbach alpha coefficient and a reliability coefficient of 0.92 was obtained, which showed a strong reliability of the research instrument.

H0: problem solving will not have any significant impact on Programming.

In testing the above hypothesis, Chi-square statistics was adopted using question asked to ascertain the impact of problem solving in programming. The results are presented in the table below:

Table 4. Score of students of programming and problem solving

		Programming								Total
		Weak		Medium		Good		Excellent		
Problem		N	%N	N	%N	N	%N	N	%N	
	Weak	65	.65	24	.24	8	.08	3	.03	100
	Medium	26	.26	52	.52	17	.17	5	.05	100
	Good	7	.07	20	.2	53	.53	20	.2	100
	Excellent	2	.02	4	.04	22	.22	72	.72	100

$$\chi^2=47.8 \quad df=9 \quad Sig=.003$$

According to table4, $\chi^2=47.8$, $df=9$ and $p<.05$ show that participants believe that problem solving has positive effect on programming.

CONCLUSION

In this study, the researchers explored the effect of problem solving in programming skills on high school students'. Moreover, they wondered what high school students think about programming. According to the quantitative results, programming did not cause any significant differences in the problem solving skills of the high school students. This result may show that programming in Scratch platform may not have an impact on their problem solving skills. This result can only be considered within the scope of this research. However, although this study was carried out over a short time period; there was a slight improvement in the students' self-confidence in their problem-solving ability. This slight improvement is also valuable for these conditions. In fact, this sheds light on the possibility that may problem-solving affect programming skills of the students.

Another point to be considered is that the students' self-perception about their problem-solving skills was found to be very low. Students have to be supported with different activities and applications that require high-order thinking in order to help students develop problem solving skills.

When the thoughts of the high students were considered, it can be clearly said that students liked programming and wanted to improve their programming. In the problem solving process, while half of the students had some difficulty, the others did not. Most of them tried to solve their problems in different ways. The favorite aspect of these applications were assigning a command to a character, learning how to write a program, adding a variable to a program, sharing what they did with others and creating their own world. The finally, most of the students found the problem solving of problem in programming if they have ability problem solving.

REFERENCES

- [1] A. Lawrence, A. Badre and J. Stasko, "Empirically Evaluating the Use of Animations to Teach Algorithms", in Proc. of the IEEE Symposium on Visual Languages, St. Louis, MO, October 1994, pp. 48-54.
- [2] T. Jenkins, "On the difficulty of learning to program", in Proc. of the 3rd Annu. LTSN_ICS Conf., Loughborough University, United Kingdom, August 2002, pp. 53-58.
- [2]Green, T. R. G., "Programming Languages as Information Structures," in Psychology of Programming, J. M. Hoc, T. R. G. Green, R. Samurcay and D. J. Gilmore, Ed., Academic Press, San Diego, 1990, pp. 117-137
- [3]Castillo, E., Conejo, A. J., Pedregal, P., Garcia, R., & Alguacil, N. (2002). Building and solving mathematical programming models in engineering and science. Journal of Applied Mathematics and Stochastic Analysis, 4, 389-391.
- [4]Clancy, M. J., & Knuth, D. E. (1977). A programming and problem-solving seminar Department of Computer Science, Stanford University.
- [5]Ferreira, C. (2002). Gene expression programming in problem solving. Soft computing and industry (pp. 635-653) Springer.
- [6]Fisher, M. L. (1981). The lagrangian relaxation method for solving integer programming problems. Management Science, 27(1), 1-18.
- [7]Hoc, J. (1983). Analysis of beginners' problem-solving strategies in programming. The Psychology of Computer use, , 143-158.

- [8]Palumbo, D. B. (1990). Programming language/problem-solving research: A review of relevant issues. *Review of Educational Research*, 60(1), 65-89.
- [9]Pea, R. D. (1987). *Logo programming and problem solving*.
- [10] Sprankle, M. (1989). *Problem solving and programming concepts* Prentice Hall PTR.

PROJE TABANLI ÖĞRENME YAKLAŞIMININ ÜSTBİLİŞSEL FARKINDALIĞA ETKİSİ İLE İLGİLİ ÖĞRENCİ GÖRÜŞLERİ

STUDENTS' VIEWS THE EFFECT OF THE PROJECT-BASED LEARNING APPROACH ON METACOGNITIVE AWARENESS

Rukiye ERSOY¹

Dr., Gazi Üniversitesi, Eğitim Fakültesi, Biyoloji Öğretmenliği Bölümü, Ankara.
rukiyebiolog@gmail.com

Hikmet KATIRCIOĞLU²

Doç. Dr., Gazi Üniversitesi, Eğitim Fakültesi, Biyoloji Öğretmenliği Bölümü, Ankara.
hturk@gazi.edu.tr

ÖZET: Çalışmanın amacı biyoloji eğitimi kapsamında uygulanan proje tabanlı öğrenme yaklaşımının ortaöğretim öğrencilerinin üstbilişsel farkındalıklarına etkisini araştırmaktır. Çalışmada nitel araştırma yönteminden yararlanılmıştır. Araştırma 2010-2011 öğretim yılı ikinci döneminde Ankara'da bulunan Özel Nene Hatun Fen Lisesi'nin 2. sınıfında öğrenim gören 15 öğrenci ile gerçekleştirilmiştir. Çalışmada "Bilinçli Birey ve Yaşanabilir Çevre" ve "Ekosistem Hizmetleri ve Sürdürülebilirlik" üniteleri 5 hafta (20 ders saati) boyunca proje tabanlı öğrenme yaklaşımı ile işlenmiştir. Sürecin sonunda öğrencilere yarı yapılandırılmış sorular yönlendirilerek veriler elde edilmiştir. Veriler betimsel analiz yöntemi kullanılarak çözümlenmiştir. Öğrencilerle yapılan görüşmeler incelendiğinde proje tabanlı öğrenme yaklaşımı ile öğrencilerin; çalışmalarını planlama, öz-değerlendirme yapma, öğrenmelerini kontrol etme, izleme gibi çeşitli üstbilişsel farkındalıklar edindikleri sonucuna ulaşılmıştır. Öğrencilerin üstbilişsel farkındalıklarını geliştirmelerine katkısı olan yaklaşımların tespit edilmesi ve bu yaklaşımlardan biri olan proje tabanlı öğrenmenin eğitim sisteminde daha etkin biçimde kullanılması önerilmiştir.

Anahtar Kelimeler: Proje tabanlı öğrenme, üstbilişsel farkındalık, biyoloji öğretimi

ABSTRACT: The aim of this study is to research the effect of the project-based learning approach, which was implemented in the scope of biology education, on secondary school students' metacognitive awareness. The interview technique, one of the quantitative research methods, were used. The study was carried with the 2nd grade students in a private science high school in the Turkish city of Ankara during second term of the Education Year 2010-2011. In the study, the units of "Conscious Individual and Liveable Environment" and "Ecosystem Services and Sustainability" were taught for 5 weeks with a project based learning approach. As for the qualitative part, the data were examined by using the descriptive analysis method. When the interviews with the students were examined, it has been observed that students in the project-based learning approach have acquired various metacognitive awareness such as planning their studies, performing self-evaluation, check their learning and monitoring.

Key Words: Project-based learning, metacognitive awareness, biology education

GİRİŞ

Proje tabanlı öğrenme değişken, görel ve hızla artan bilgiyi, son derece sınırlı zaman dilimlerinde, teknoloji tabanlı öğrenme ortamında ve bireyi, problem çözebilen, analitik ve eleştirel düşünebilen, araştırma yapabilen, karar verebilen, sorumluluk alabilen ve iş birliği içinde çalışabilen bir birey haline getirebilecek biçimde kazanmamızı sağlayabilecek güçte bir anlayıştır (Erdem, 2002).

Proje tabanlı öğrenme yönteminin karakteristik özellikleri şöyle sıralanabilir:

- Öğrenenler öğrenme görevlerini belirleyebilirler
- Öğrenenler çözüm sürecini kendileri tasarlarlar
- Öğrenenler çözüm için bilgileri toplamak ve düzenlemekle yükümlüdürler
- Öğrenenler düzenli olarak yaptıklarını arkadaşları ve öğretmenleriyle paylaşırlar
- Sınıf ortamı değişim ve hataları tolere edebilecek şekilde oluşturulmuştur
- Süreç değerlendirme için önemlidir (Başbay, 2005).

Proje tabanlı öğrenmenin sayılan özelliklerine baktığımızda kişinin nasıl öğrendiğini kontrol etmesi, öğrenmeyi planlaması ve öğrenmesini değerlendirmesi gibi üstbilişsel aktiviteleri içerdiği görülmektedir.

Üstbiliş, öğrenmenin kendi kendine oluşmasını sağlayan becerileri kapsar. Bireyde bilişsel farkındalık yani üstbiliş ile ortaya çıkması beklenen beceriler şöyle sıralanabilir:

- Kişinin kendisinin ve öğrenme yollarının farkında olması
- Bilinçli davranma
- Kendini kontrol
- Planlama
- Nasıl öğrendiğini izleme
- Kendini düzenleme
- Kendini değerlendirme (Doğanay, 1997).

Üstbilişsel farkındalık ise amacın ve kişisel kaynakların tanımlanarak bireyin bildiklerinin, motivasyon ve kaygı düzeylerinin, ihtiyaçlarının farkında olarak değerlendirmeyi nasıl yapacağını belirlemesidir (Ertmer ve Newby,1996: Akt. Yavuz, 2009).

Araştırmanın Amacı ve Önemi

Öğrencilerin sahip olmadan başarıya ulaşmalarının güç olduğu üstbilişsel farkındalık gibi özelliklerin nasıl kazandırılacağı ile ilgili araştırmalar oldukça kısıtlıdır. Çeşitli faktörlerin bu unsurlar üzerinde etkisi incelenmişse de günümüz eğitim sisteminde önemli bir yere sahip olan proje tabanlı öğrenmenin üstbilişsel farkındalığı nasıl etkilediği hususu eksik kalmıştır. Bu araştırmada öğrenmeyi öğrenmek çıkış noktasına sahip olan proje tabanlı öğrenmenin, yine aynı çıkış noktasından yola başlayan üstbilişsel farkındalığa etkisi araştırılmıştır.

Araştırmanın amacı, biyoloji eğitimi kapsamında uygulanan proje tabanlı öğrenme yaklaşımının ortaöğretim öğrencilerinin üstbilişsel farkındalıklarına etkisini araştırmaktır.

Araştırmanın problemi ise ‘Ortaöğretim öğrencilerinin proje tabanlı öğrenme yaklaşımının üstbilişsel farkındalıklarına etkisi ile ilgili görüşleri nelerdir?’ şeklindedir.

YÖNTEM

Bu çalışmada nitel araştırma yöntemlerinden sıklıkla kullanılan yaklaşımlardan biri olan görüşme tekniği kullanılmıştır. Bu tekniğin kullanıldığı çalışmalarda öncelikli amaç, çalışılan örneklemden elde edilen sonuçların örneklemin temsil ettiği evrene genellenmesi değildir. Amaç, sonuçların çalışılan kişilere benzer ya da aynı özellik gösteren kişilere genellenmesidir. Bu nedenle görüşme gibi nitel araştırma tekniklerinin kullanıldığı çalışmalarda örneklem seçimine ilişkin çok sıkı kurallar yoktur (Türmüklü, 2000).

Katılımcılar

Çalışma 15 kişi ile yürütülmüştür. Çalışma grubundaki öğrencilerin tamamı kızdır. Yaşları 16-18 arasında değişmektedir. Öğrenciler fen lisesinde bulunmaları ile de paralel olarak yüksek akademik başarıya sahip öğrencilerdir.

Veri Toplama Süreci

Araştırma 2010-2011 eğitim-öğretim yılının ikinci döneminde 9 Mayıs tarihinde başlayıp 10 Haziran tarihinde sona ermiştir. Toplamda 5 hafta süren çalışma Biyoloji dersi kapsamında ‘Bilinçli Birey Yaşanabilir Çevre’ ve ‘Ekosistem Hizmetleri ve Sürdürülebilirlik’ üniteleri boyunca gerçekleştirilmiştir. Çalışmanın yapıldığı sınıfların haftalık Biyoloji ders saatleri 4’tür yani çalışma toplamda 20 ders saati sürmüştür.

Yarı Yapılandırılmış Görüşme Soruları

Sorular, araştırmacı tarafından hazırlanmıştır ve belirtilen konuların değerlendirilmesine uygunluk bakımından araştırmacıdan bağımsız, 2 farklı uzman tarafından incelenmiştir.

Verilerin Analizi

Görüşmelerden elde edilen veriler betimsel analiz yöntemi kullanılarak çözümlenmiştir. Betimsel analiz yaklaşımı, verilerin araştırma sorularının ortaya koyduğu temalara göre organize edilmesine ve görüşmede kullanılan sorular veya boyutlar dikkate alınarak sunulmasına imkan vermektedir (Yıldırım ve Şimşek, 2011).

BULGULAR

Bu bölümde öğrencilerin sorulara verdiği cevaplar tablolar halinde sunulmuştur.

Soru 1. Proje tabanlı öğrenme yaklaşımı size zihinsel anlamda güçlü ve zayıf yönlerinizi öğretti mi? Örneklerle açıklar mısınız?

Tablo 1. Birinci Soruya Öğrencilerin Verdiği Cevaplar

	f	%
Zihinsel anlamda güçlü ve zayıf yönlerimi öğrendim	11	78,5
Görsel yönümün daha güçlü olduğunu anladım	4	28,5
İşitsel yönümün daha güçlü olduğunu anladım	2	14,2
Sosyal yönümle ilgili bilgi edindim	2	14,2
Aktif olduğumda daha kolay öğrendiğimi anladım	4	28,5

Birinci soruyu 14 öğrenci cevaplamıştır. Açıklayıcı bilgi alt boyutunu ölçmeye yönelik bir sorudur. Bu alt boyut bireylerin öğrenme görevlerinin yapılarına, bilişsel amaçlarına ve kişisel yeteneklerine ilişkin inançlarını içerir. Öğrencilerin % 78,5'i proje tabanlı öğrenme yaklaşımının kendilerine zihinsel anlamda güçlü ve zayıf yönlerini öğrettiğini söylemişlerdir. Bununla birlikte bu çalışma sonucunda öğrencilerin % 28,5'i görsel, % 14,2'si işitsel yanlarının güçlü olduğu çıkarımına varırken, % 14,2'si sosyal yönü hakkında bilgi edindiklerini % 28,5'i ise aktif olduklarında daha kolay öğrendiklerini belirtmişlerdir (Tablo 1).

Soru 2. Proje çalışmaları sayesinde bilgileri hatırlama ve düzenleme becerilerinizin gelişeceğini düşünüyor musunuz?

Tablo 2. İkinci Soruya Öğrencilerin Verdiği Cevaplar

	f	%
Bilgileri hatırlama ve düzenleme becerilerim gelişti	13	86,6
Kendim yaptığım için daha çok akılda kalıcı olur	5	33,3
Konuyu ayrıntılarıyla incelediğimiz için daha akılda kalıcı olur	2	13,3
Görsel olduğu için daha akılda kalıcı olur	3	20
Bilgiler bu şekilde daha sistemli oluyor	2	13,3

İkinci soruyu 15 öğrenci cevaplamıştır. Açıklayıcı bilgi alt boyutunu ölçmeye yönelik bir sorudur. Öğrencilerin % 86,6 sı proje tabanlı öğrenme yaklaşımının bilgileri hatırlama ve düzenleme becerilerini geliştirdiğini söylerken % 33,3 kendileri yaparak öğrendikleri için, % 13,3 ü konular ayrıntılı incelendiği, %20 si görsel olduğu için daha akılda kalıcı olduğunu, %13,3 ü bilgilerin bu şekilde daha düzenli ve sistemli olduğunu belirtmişlerdir (Tablo 2).

Soru 3: Proje çalışmanız sırasında ne tür yöntemler kullandınız?

Tablo 3. Üçüncü Soruya Öğrencilerin Verdiği Cevaplar

	f	%
Çalışırken ne tür yöntemler kullandığının farkındayım	15	100
İnternet araştırması yaptık	15	100
DeneySEL yöntem kullandık	2	13,3

Üçüncü soruyu 15 öğrenci cevaplamıştır. Prosedürel bilgi alt boyutuna yönelik bir sorudur. Bu alt boyut problemi çözmek için stratejilerin nasıl kullanılacağı hakkındaki bilgiyi ve bireyin bilgi ve becerileri kullanma ve düzenleme düzeylerini değerlendirmektedir. Öğrencilerin % 100 proje çalışması sırasında ne tür yöntemler kullandıklarının farkında olduklarını söylemişlerdir. % 100'ü internet araştırması yaptıklarını belirtirlerken %13,3 'ü deneySEL yöntem kullandıklarını söylemişlerdir (Tablo 3).

Soru 4: Proje çalışmanızda aktif görev almanız sizi motive etti mi?

Tablo 4. Dördüncü Soruya Öğrencilerin Verdiği Cevaplar

	f	%
Aktif görev almak beni motive etti	10	66,6

Aktif görev almak beni mutlu etti	2	13,3
Aktif olmamayı tercih ederdim	4	26,6

Dördüncü soru 15 öğrenci tarafından cevaplandırılmıştır. Bu soru durumsal bilgi alt boyutunu ölçmeye yönelik bir sorudur. Bu alt boyut bireyin açıklayıcı ve prosedürel bilgiyi ne zaman ve niçin kullanacağını ölçmektedir. Öğrencilerin % 66,6 'sı aktif görev almanın kendilerini motive ettiğini % 13,3 'ü aktif görev almaktan dolayı mutlu olduklarını belirtmişlerdir. Bununla birlikte % 26,6'sı aktif olmamayı tercih ettiklerini söylemişlerdir (Tablo 4).

Soru 5: Proje çalışmanızın başında zamanınızı organize ettiniz mi? Zamanlamanıza uydunuz mu?

Tablo 5. Beşinci Soruya Öğrencilerin Verdiği Cevaplar

	f	%
Zamanımızı organize ettik	13	86,6
Zaman çizelgemize uyduk	11	73,3

Beşinci soruyu 15 kişi cevaplamıştır. Bu soru planlama alt boyutun yöneliktir. Planlama alt boyutu bireyin uygun öğrenme stratejilerini seçmesini ve etkili performans için bilişsel kaynaklarını işe koşmasını içerir. Öğrencilerin %86,6'sı proje çalışmalarına başlamadan önce zamanlarını organize ettiklerini söylerken %73,3'ü ise zamanlama çizelgelerine uyduklarını belirtmişlerdir (Tablo 5).

Soru 6: Proje çalışmanıza başlamadan önce nasıl bir yol izlediniz?

Tablo 6. Altıncı Soruya Öğrencilerin Verdiği Cevaplar

	f	%
Çalışmaya başlamadan önce görev dağılımı yaptık	13	86,6
Çalışmaya başlamadan önce konuları dağıttık	4	26,6
Çalışmaya başlamadan önce farklı yollar düşündük	1	6,6
Çalışmaya başlamadan önce araştırma yaptık	4	26,6

Altıncı soruyu 15 öğrenci cevaplamıştır. Planlama alt boyutuna yöneliktir. Öğrencilerin % 86,6'sı çalışmaya başlamadan önce görev dağılımı yaptıklarını, % 26,6'sı konu dağılımı yaptıklarını, yine % 26,6'sı araştırma yaptıklarını ve % 6,6'sı da farklı yollar düşündüklerini belirtmişlerdir (Tablo 6).

Soru 7: Proje çalışmalarınız sırasında ara verip ne yaptığınızı, konuyu öğrenip öğrenmediğinizi kontrol ettiniz mi?

Tablo 7. Yedinci Soruya Öğrencilerin Verdiği Cevaplar

	f	%
Çalışmamız sırasında ara verip kendimizi kontrol ettik	13	86,6

Yedinci soruyu 15 kişi cevaplandırmıştır. İzleme alt boyutunu ölçmeye yönelik bir sorudur. İzleme; bireyin performansını analiz etmesini, gelecekteki performansı hakkında kestirimlerde bulunmasını, öğrenme stratejilerinin verimliliğini değerlendirmesini ve performans hatalarını saptamasını yansıtmaktadır. Öğrencilerin % 86,6'sı proje çalışmaları sırasında ara verip çalışmalarını kontrol ettiklerini belirtmişlerdir (Tablo 7).

Soru 8: Sence proje çalışmandan kaç puan alırsın?

Tablo 8. Sekizinci Soruya Öğrencilerin Verdiği Cevaplar

	f	%
Çalışmadan kaç puan alabileceğini tahmin edenler	12	80

Sekizinci soruyu 15 kişi cevaplandırmıştır. Değerlendirme alt boyutunu ölçmeye yönelik bir sorudur. Değerlendirme bireyin öğrenme çıktıları ve verimliliğini değerlendirmesini belirlemektedir. Öğrencilerin % 80'i proje çalışmalarının sonucunu değerlendirebilmişlerdir (Tablo 8).

Soru 9: Projelerinizi hazırlarken anlayamadığınız bir şey olduğunda grup arkadaşlarınızdan yardım istediniz mi?

Tablo 9. Dokuzuncu Soruya Öğrencilerin Verdiği Cevaplar

	f	%
Anlayamadığım konularda arkadaşlarımdan yardım istedim	8	80
Anlayamadığım konu olmadı	2	20

Dokuzuncu soruyu 10 öğrenci cevaplamıştır. Hata ayıklama alt boyutunu ölçmeye yönelik bir sorudur. Bu alt boyut bireyin performans ve kavramasındaki hataları düzeltilmesini içermektedir. Proje çalışmaları sırasında öğrencilerin % 80'i anlayamadıkları konularda arkadaşlarından yardım istediklerini belirtirken % 20'si anlayamadığı bir konunun olmadığını söylemişlerdir (Tablo 9).

SONUÇ

Çalışmadan elde edilen sonuçlar şöyle sıralanabilir;

- Öğrenciler proje tabanlı öğrenme yaklaşımı sayesinde nasıl daha iyi öğrenebildikleri (duyarak, görerek, aktif olduklarında) hakkında da bilgi edindiklerini belirtmiştir.
 - Öğrenciler proje tabanlı öğrenmede konu ayrıntılarıyla ele alındığı için ve bu yaklaşım daha görsel olduğu için öğrendiklerinin uzun süre akılda kalacağını belirtmişlerdir. Ayrıca bilgilerin bu yöntemle daha sistemli olduğunu söylemişlerdir.
 - Öğrenciler proje tabanlı öğrenme yönteminde aktif oldukları için daha mutlu olduklarını ve bunun da öğrenme motivasyonlarını arttırdığını belirtmiştir.
 - Öğrencilerin bu proje tabanlı öğrenme ile çalışırken kullandıkları yöntemlerin farkında oldukları görülmüştür.
 - Görüşmelerden elde edilen cevaplardan proje tabanlı öğrenme yaklaşımının öğrencilere *planlama* gibi üstbilişsel farkındalıklar kazandırdığı sonucuna ulaşılmıştır.
 - Öğrencilerin çoğu proje tabanlı öğrenme sürecinde *izleme* yaparak, performanslarını analiz ederek, gelecekteki performansları hakkında kestirimlerde bulunup, öğrenme stratejilerinin verimliliğini değerlendirmişler ve performans hatalarını saptamışlardır.
 - Proje tabanlı öğrenme sürecinin sonunda öğrencilerin *değerlendirme* yaparak öğrenme çıktılarını ve verimliliği hakkında bir fikir sahibi oldukları sonucuna varılmıştır.
 - Öğrencilerin büyük bir kısmı proje tabanlı öğrenme sürecinde üstbilişsel bir farkındalık olan *hata ayıklamayı* gerçekleştirerek performans ve kavramalarındaki hatalarını düzeltmeye çalışmışlardır.
- Sonuçlar özetlenecek olursa, öğrencilerle yapılan görüşmeler incelendiğinde proje tabanlı öğrenme yaklaşımı ile öğrencilerin çalışmalarını planlama, öz değerlendirme yapma, öğrenmelerini kontrol etme, izleme gibi çeşitli üstbilişsel farkındalıklar edindikleri görülmektedir.

ÖNERİLER

- Öğrencilere bilgiyi öğretmek yerine 'öğrenmeyi öğretmek' toplumun ve bireylerin geleceği açısından çok daha yararlı bir yaklaşım olacaktır. Bu nedenle öğrencilerin üstbilişsel farkındalıklarını artırma yolları tespit edilip eğitim sisteminin o doğrultuda geliştirilmesi önerilmektedir.
- Proje tabanlı öğrenme yaklaşımı dışındaki öğretim modellerinin de üstbilişsel farkındalığa etkisi araştırılıp bu modeller arasında karşılaştırmalar yapılabilir.
- Bu çalışma farklı disiplinlerde ve ortaöğretim dışındaki öğretim kademelerinde de yapılabilir. Aynı konu farklı araştırma desenleri ve farklı katılımcı sayısı ile tekrar çalışılabilir.

KAYNAKLAR

- Başbay, A. (2005). Basamaklı öğretim programıyla desteklenmiş proje tabanlı öğrenme yaklaşımının öğrenme sürecine etkileri. *Ege Eğitim Dergisi*. 6 (1), 95-116.
- Doğanay, A. (1997). Ders dinleme sırasında bilişsel farkındalık ile ilgili bilgilerin kullanımı. *Çukurova Üniversitesi Eğitim Fakültesi Dergisi*, Cilt: 1, Sayı: 11.
- Erdem, M. (2002). Proje tabanlı öğrenme. *Hacettepe Üniversitesi Eğitim Fakültesi Dergisi*, 22, 172-179.
- Türnüklü, A. (2000). Eğitim bilim araştırmalarında etkin olarak kullanılabilir nitel bir araştırma tekniği: görüşme. *Kuram ve Uygulamada Eğitim Yönetimi Dergisi*, 6(24), 543-559.
- Yavuz, D. (2009). *Öğretmen adaylarının öz-yeterlik alguları ve üstbilişsel farkındalıklarının çeşitli değişkenler açısından incelenmesi*. Yüksek Lisans Tezi. Zonguldak Karaelmas Üniversitesi Sosyal Bilimler Enstitüsü, Zonguldak.
- Yıldırım, A. ve Şimşek, H. (2011). *Sosyal Bilimlerde Nitel Araştırma Yöntemleri*. (8. Baskı). Ankara: Seçkin Yayıncılık.

CONTEXTUALIZED LEARNING SETTINGS FOR MEANINGFUL NATURE OF SCIENCE UNDERSTANDING

Kader BİLİCAN

Jale CAKİROGLU

Ceren OZTEKİN

It was claimed that reaching the goal of totally scientific literate people could be achieved by in science courses if students were taught about nature of science (NOS). Even though nature of science understanding has been claimed to be an important learning outcome for science education for a long time, research studies have consistently have indicated both pre- and in-service science teachers' naïve NOS ideas ((Abd-El-Khalick, 2005). Yet, science teachers' naïve understanding of NOS has been crucial factor keeping them emphasizing NOS explicitly and reflectively which also lead students acquiring undesired NOS views (Akerson, Buzelli, & Donnelly, 2008). Thus, developing more desired views of NOS for science teachers has been first step to ensure more appropriate NOS emphasize in classes. Considering the success of explicit reflective NOS instruction for improving NOS views, it has often has been undertaken through decontextualized settings to improve pre-service science teachers' NOS views. Although decontextualized explicit reflective NOS instruction provided learners with opportunities to revise their NOS views without struggling science content, they were not alone sufficient to help develop deeper NOS understanding (Clough, 2006). Although there has been some evidence related to impact of contextualized settings on NOS views, it is still unknown how the designing combination of different contextualized settings coupled with explicit-reflective NOS would work for pre-service science teachers' NOS views. Therefore, this study aimed to reduce lack of information related to contribution of contextualized settings to gain deeper NOS understanding for pre-service science teachers. The present study focused on helping pre-service teachers develop their NOS views within a combination of different contextualized settings coupled with explicit reflective NOS instruction. It was concluded that contextualized settings had a huge contribution to promote NOS views. Further results and implications of study will be discussed

Keywords: nature of science understanding, pre-service teacher education

THE INFLUENCE OF INITIAL TEACHER TRAINING IN FUTURE TEACHERS' PERCEPTIONS ABOUT MATHEMATICS TEACHING AND LEARNING

Isabel Cláudia NOGUEIRA
Escolar Superior de Educação de Paula Frassinetti, Porto, Portugal
isa.claudia@esepf.pt

ABSTRACT: Assuming that teachers' knowledge about mathematics teaching and their beliefs and conceptions about mathematics and about mathematics teaching and learning are related (Ball, 1991; Thompson, 1997), that future teachers' beliefs act as previous knowledge in their formative experiences (Tardif, 2002) and that those beliefs are dynamic, once its confrontation with others beliefs can modify them (Vila and Callejo, 2006), we are developing a longitudinal study which intends to determine the influence of undergraduate degree on Primary Education in conceptions that students, future teachers, have about mathematics and about mathematics teaching and learning processes.

In this paper, we present preliminary data obtained in academic year 2012/2013 from two different groups of students, future teachers, of the undergraduate degree on Primary Education of Paula Frassinetti School of Education: a students' group at the beginning of its teacher training studies and a students' group at the end of this study cycle.

Key words: Teachers Training, Primary Education, Mathematics, Conceptions

INTRODUCTION

Developed by Freema Elbaz, Alba Thompson and Deborah Ball and recognized by, the first studies on conceptions about mathematics and its influence on teaching and learning of this discipline in the various levels of education contributed decisively for a deeper understanding by the mathematics educators community of which factors should be taken into account in its curricular development, allowing to identify the enablers or hindering elements in its teaching and learning. In the early 80s, personal beliefs were identified as filters of all kinds of teachers knowledges: according to Elbaz (1983), a knowledge guiding their practice; Ball (1991) emphasizes the interaction between teachers' knowledge about mathematics and their conceptions about this subject, referring to his influence on their practices, belief also supported by Thompson (1997).

The formative practices experienced by students in their academic pathways and conceptions associated with them are identified as decisive not only in their academic achievements but are of particular relevance in their future professional practice. In this context, Tardif considers future teachers conceptions as previous knowledge regulators, both from their training experiences as from their results, considering that their professional practice is based on judgments interiorized from school traditions and in their lived experience, from which the past enables them to clarify the present and anticipate the future (Tardif, 2002). More recently, Vila and Callejo stated that beliefs develop from experiences and perceptions and enhanced the dynamic character of perceptions, since they can be modified by experience or contrast with other perceptions (Vila & Callejo, 2006).

Aware that beliefs about mathematics are mainly built in the school and that they define the vision and the application given to mathematics and assuming that they have an important role in future teachers training, in school year 2012/2013 we implemented a longitudinal study which main objective is to determine the influence of the undergraduate degree on Primary Education in future teachers conceptions about mathematics and about the teaching and the learning of mathematics.

THE CONTEXT

In a more scientific approach or emphasizing educational knowledge in the specific area of mathematics, the undergraduate degree on Primary Education - necessary condition to obtain qualification for teaching in Preschool Education and in 1st or 2nd cycles of Primary Education - includes mandatory courses in mathematics in its training components. The curricular structure of this undergraduate degree includes six courses (summing 30 ECTS credits) focused on Mathematics and Mathematics Education: Development of Mathematical Logical Reasoning, Numerical Structures, Geometry Topics, Introduction to Statistics, Mathematics Communication and Didactics of Mathematics.

The first of these curricular units, Development of Mathematical Logical Reasoning, provides an initial contact with the specificities of the processes of construction and development of the main logical-mathematical

structures. The following four courses (Numerical Structures, Geometry Topics, Mathematics Communication and Introduction to Statistics) are allocated to the training component of the teaching of mathematics, and include the presentation and exploration of concepts, relations, operations and logical-mathematical representations, covering mathematical knowledge needed to the desirable mathematics best practices in Primary Education. The organization and the construction of educational and didactic knowledge in the specific area of mathematics - essential to the design and implementation of educational contexts that promote the development of logical and mathematical reasoning in the areas of early childhood education and in the aim of the 1st and 2nd cycles of primary education - justify the inclusion of the course of Didactics of Mathematics in the last semester of the undergraduate degree on Primary Education curricular structure.

METHODS AND PROCEDURES

The data we present has been obtained in academic year 2012/2013 from two different groups of students, future teachers, of the undergraduate degree on Primary Education of Paula Frassinetti School of Education, in Porto, Portugal: a students' group at the beginning of its teacher training studies (Group 1) and a students' group at the end of this study cycle (Group 2). Data collection was carried out in September 2012 in Group 1 (before any formative action related to mathematics, their teaching and their learning) and in Group 2 in June 2013 at the end of those students' graduations.

Students were requested to fill out a questionnaire survey proposed by Godino (2004). With a Likert type scale, students had to specify their level of agreement or disagreement with 9 statements, according to the following convention: completely disagree; disagree; neither agree nor disagree; agree and completely agree.

All students were informed about the objectives underlying the preparation and implementation of this study and their anonymity was guaranteed.

RESULTS AND FINDINGS

The sample consists of 148 individuals and is almost entirely composed of female students (about 97% of respondents).

Table 1 presents those participants characterization:

Table 1. Sample Description

Variables	N	Gender		Age	X
		Female	Male		
Group 1.	70	68	2	17-30	19.5
Group 2.	78	75	3	20-27	21.9
TOTAL	148	143	5		

The answers provided by the questionnaire survey somehow reflect conceptions and representations revealed by these students about mathematics teaching and learning processes. In fact, data presented in Figure 1 allow not only some considerations regarding the conceptions expressed by these students about mathematics teaching and learning approaches but also provides information that can relate those conceptions with the students' formative level.

The overwhelming majority of these students believe that the teaching of mathematics should be initiated with the exploration of simple concepts and direct procedures and these should gradually progress to more elaborate conceptualizations and procedures (item that collect over 80% of responses of partial or total agreement). Regarding the implementation of any process of math instruction, the two groups responded in a similar way: only about 5% of students in each group disagrees with the need of progression in the activities level of difficulty and the opposite view is expressed by about two-thirds of students in each group, which partially or totally agree with the necessity of such progress.

More than 90% of respondents of both groups agree partially or completely by considering that one of the duties of the teacher is to provide feedback about the activities carried out by students; it seems to have no significant differences in the responses provided by the two groups in these two items.

Half of the respondents from Group 2 consider that teachers should act quickly in classroom disagreements in order to prevent disruptive behaviors but that figure rises to two-thirds in Group 1 responses. In both groups, none of the respondents are in complete agree with the conception of the teacher as someone who decides what is and is not correct; we should note, however, that about 40% of the students in Group 2 expressed not agree or disagree with teacher's role as judge.

A significant number of these students associate autonomy to individual work - 65% of students in Group 1 and 70% in Group 2 converge in partial or total agreement that performing tasks individually promotes students autonomy -, but the percentage of respondents in Group 2 who established this explicit link is almost half the rate that occurred in Group 1.

About half of the students from both groups responded neither agree nor disagree on the influence of the use of non-standard procedures in learning the standard ones, and disagreement with the existence of this influence is similar in both groups (answer selected by nearly one-third of the students).

Noteworthy is the difference in perceptions expressed by the two groups on the mathematical abilities of young children. In Group 2, almost 80% of the responses indicate that these students disagree that the lack of experience and knowledge makes young children unable mathematically, whereas this figure drops to under 50% in the answers of students in Group 1. The statement that good organization and appropriate sequencing of classes are necessary conditions for children to understand mathematics collects the partial or complete agreement of over 60% of responses in both Group 1 and Group 2.

In Figure 1 we can find a graphic representation of the responses provided:

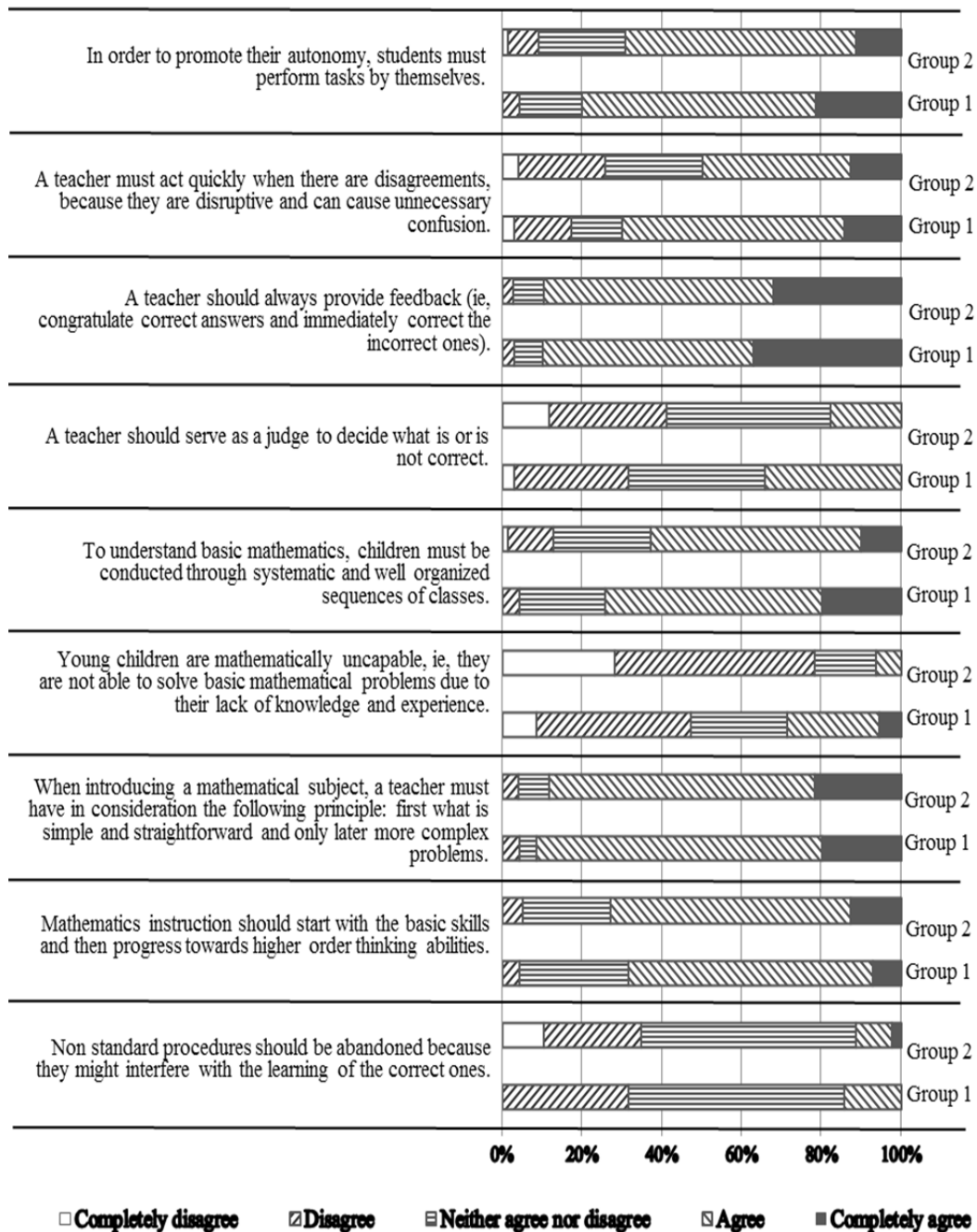

Figure 1. Participants Conceptions about Mathematics Teaching and Learning Processes

CONCLUSIONS

It is known that both students as classes in which they participate are influenced by the vision of the teacher who teaches mathematics. The clash of a teacher with his own vision of mathematics seems to us a key moment in the construction of their professionalism: the participation of these future teachers in this study can already be considered as an important contribution in this construction.

For its part, it is recognized some reciprocity in the process of elaboration of conceptions: first, the training experiences lived by students in learning mathematics play a decisive role in their conceptions of this discipline, about the context of their learning and about their own learning abilities; moreover, the constructed and (re)constructed conceptions - in particular as a result of these formative processes - are also responsible for the mathematical approaches that they will bring for their students when teaching.

The questions proposed to these students allowed the presentation of these preliminary data, making possible to access and describe some of the processes of change of conceptions along their learning paths.

The perceptions expressed by students, future teachers, who participated in this study are largely the product of their own mathematical experiences, prior to its entry in the undergraduate degree on Primary Education, for one group, and also a consequence of its attendance in that course, for the other group. The value of teaching methods that emphasize the implementation of training sequences that depart from simple and direct approaches and progress to more elaborate conceptualizations may indicate that some of the most striking trends and current math education, such as problem solving, performing research tasks and projects in the mathematics classroom (NCTM, 2007; Ponte *et al*, 2007), may not have been experienced by these students or not been experienced by them as effective methods for mathematical learning.

It is also interesting to note that although they refer to individual work as a way of promoting autonomy, these students also understand how essential is the task of the teacher in providing feedback as soon as an incorrect answer is given, which can somehow indicate some lack of autonomy in activities development, pointed as one of the objectives for the discipline of mathematics already in Primary Education (Ponte *et al*, 2007).

From the analysis of these cases emerged a deeper knowledge about the relationship established at two levels: the action between the students and the learning and development of their students, and between the action of teachers and the development of students.

REFERENCES

- Ball, D. (1991). *Knowledge and reasoning in mathematical pedagogy: examining what prospective teachers bring to teacher education*. Retrieved from <http://www.personal.umich.edu/~dball/>.
- Cury, H. N. (1999). Concepções e crenças dos professores de matemática: pesquisas realizadas e significados dos termos utilizados. *Bolema*, 12 (13): 29-44.
- Elbaz, F. (1983). *Teacher thinking: a study of practical knowledge*. Londres: Croom Helm.
- Godino, J. (Dir.) (2004). *Didáctica de las Matemáticas para Maestros*. Granada: Departamento de Didáctica de la Matemática, Facultad de Ciencias de la Educación Retrieved from <http://www.ugr.es/~jgodino/>.
- NCTM (2007). *Principios e Normas para a Matemática Escolar*. Lisboa: Associação de Professores de Matemática.
- Ponte, J. P. (1997). Concepções de professores de Matemática e processos de formação. In Ponte, J.P. (Ed.). *Educação Matemática: Temas de investigação*. Lisboa: Instituto de Inovação Educacional.
- Ponte, J.P. *et al* (2007). *Programa de Matemática do Ensino Básico*. Lisboa: ME-DGIDC.
- Tardif, M. (2002). *Saberes Docentes e Formação Profissional*. Petrópolis: Vozes.
- Thompson, A. (1997). A relação entre concepções de matemática e de ensino de matemática de professores na prática pedagógica. *Zetetiké*, Campinas: Unicamp, 5 (8): 11-44.
- Vila, A. & Callejo, M. L. (2006). *Matemática para aprender a pensar: o papel das crenças na resolução de problemas*. Porto Alegre: Artmed.

SINIF ÖĞRETMENİ ADAYLARININ UZUNLUK ÖLÇME KONUSUNDA ÖĞRENCİLERİN KAVRAM YANILGISILARINI TESPİT ETME DURUMLARI

THE DETERMINING SITUATIONS OF THE PRE-SERVICE PRIMARY TEACHERS' THE MISCONCEPTIONS OF THE STUDENTS RELATED TO THE LENGTH MEASUREMENT SUBJECT

Nurullah ŞİMŞEK

Cumhuriyet Üniversitesi, Eğitim Fakültesi. Matematik Eğitimi Anabilim Dalı
nsimsek@cumhuriyet.edu.tr

Nihat BOZ

Gazi Üniversitesi, Eğitim Fakültesi. Matematik Eğitimi Anabilim Dalı
boz@gazi.edu.tr

ÖZET: Ölçme konusunda öğrencilerin ilk karşılaştıkları ve anlamada zorlandıkları konu uzunluktur. Uzunluk ölçümü konusunda öğrencilerde sık görülen kavram yanlışlarından birisi öğrencilerin birimleri saymak yerine noktaları veya cetvel üzerindeki çizgileri saymayı tercih etmesidir (Batista, 2006; Boulton-Lewis ve ark., 1996; Zembat, 2009). Öğrencilerin uzunluk ölçümüne ilişkin kavramsal anlamayı gerçekleştirebilmelerine yardım edebilmek için öğretmenlerin bu ve benzeri kavram yanlışlarının farkında olmaları gerekmektedir. Dahası öğrencilerin anlamlı öğrenmesinin önündeki engellerin aşılması için bu engellerin farkında olan öğretmenlerin yetiştirilmesi gerekir. Çünkü hastalığın teşhisi tedavi için çok büyük önem arz etmektedir. Bu bağlamda geleceğin önemli öğretmenlerinden olan sınıf öğretmeni adaylarının öğrenci kavram yanlışlarını tespit edemedikleri araştırılmıştır. Veriler sınıf öğretmenliği son sınıfta öğrenim gören 85 öğretmen adayına uygulanan anketlerle toplanmıştır. Verilerin analizi sonucunda, çalışmaya katılan öğretmen adaylarının %59'nun kavram yanlışını tespit edemedikleri görülmüştür

Anahtar sözcükler: Kavram Yanılgısı, Sınıf Öğretmeni Adayı, Uzunluk Ölçme

ABSTRACT: Length is the first measurement subject that students encounter and face challenges in order to understand. One of the misconceptions observed among the students with respect to length measurement subject is that they prefer counting the points and the lines on the ruler instead of counting the units (Batista, 2006; Boulton-Lewis et al., 1996; Zembat, 2009). Teacher should have awareness regarding these misconceptions and similar ones in order to help students grasp the length measurement conceptually. Because the diagnosis of the disease is of great importance for the treatment of the disease. Within this scope, this study investigated to what extent the pre-service primary teacher, who are the important future teachers, are able to determine the misconceptions of the students. Data were collected through the questionnaires administered to the 85 pre-service primary teachers. At the end of the data analysis, it was found that 59% of pre-service teacher into the study were not able to determine the misconceptions.

Key words: Misconceptions, Pre-Service Primary Teachers, Length Measurement

GİRİŞ

Ölçme, insanların günlük hayatta geçmişten günümüze her alanda ihtiyaç duyduğu önemli kavramlardan birisidir. Ekonomi, ticaret, inşaat, ulaşım gibi birçok meslek sektörlerinde kullanılmaktadır. Günlük hayatta böyle önemli olan ölçme, matematikte de geometri, istatistik, sayılar gibi alanlarla ilişkili bir konudur. Hem günlük hayatta hem de matematiğin farklı alanlarında sıklıkla karşılaşılan ölçme kavramı Milli Eğitim Bakanlığı'nca hazırlanan matematik öğretim programlarında da önemli bir yer teşkil etmektedir.

Ölçme konusunda ilkökulda öğrencilerin ilk karşılaştıkları nitelik ise uzunluktur. (MEB, 2009). Uzunluk öğrencilerin ölçmeyi öğrendikleri ilk nitelik olmasına rağmen uzunluk ölçümünün anlaşılması kolay olmamaktadır (Van De Walle, Karp ve Bay-Williams, 2012). Uzunluk ölçümü ilkökulun ilk yıllarından itibaren öğrencilere öğretilmesine rağmen öğrenciler yukarıda ifade edildiği şekilde kavramsal olarak anlamadan ezbere öğrendikleri yöntemlerle sonuca ulaşmaya çalıştıkları görülmektedir. Bu durumun olumsuz bir sonucu olarak

öğrenciler kavram yanlışlarına düşmektedir (Emekli, 2001; Şişman ve Aksu, 2009; Zembat, 2009). Uzunluk ölçümü konusunda öğrencilerde sık görülen kavram yanılığı, öğrencilerin birimleri saymak yerine noktaları veya cetvel üzerindeki çizgileri saymayı tercih etmesidir (Batista, 2006; Boulton-Lewis ve ark., 1996; Barrett ve ark., 2003; Kamiî, 1995:akt., Zembat, 2009; Van De Walle, Karp ve Bay-Williams, 2012). Bu bahsedilen kavram yanılığı eğer ilkökul yıllarında sınıf öğretmenleri tarafında fark edilip giderilmezse sonraki sınıflarda öğrenciler çevre uzunluğunu içeren problemleri incelerken uzunluk kavramı ile ilgili zorluklar yaşamaktadır (Van De Walle, Karp ve Bay-Williams, 2012).

Kavram yanlışlarının giderilmesi hususunda birinci adım olarak kavram yanlışlarının farkında olan sınıf öğretmenlerinin yetiştirilmesinin çok önemli olduğu düşünülmektedir. Çünkü hastalığın tedavisinde doktorun hastalığı tespit etmesi çok büyük önem arz etmektedir. Bu bağlamda çalışmanın amacı, öğretmen adaylarının uzunluk ölçümü konusunda yukarıda bahsedilen öğrenci kavram yanılığını tespit edip edemediklerini incelemektir. Bu amaç doğrultusunda aşağıda belirtilen araştırma sorusuna yanıt aranmıştır.

Sınıf öğretmeni adayları uzunluk ölçümü konusunda yukarıda bahsedilen öğrenci kavram yanılığını tespit edebiliyorlar mı?

YÖNTEM

Araştırma Modeli

Bu çalışmada genelde nitel araştırma özelde de durum çalışması araştırma modeli olarak belirlenmiştir.

Çalışma Grubu

Bu çalışma 2013-2014 öğretim yılında bir devlet üniversitesinin eğitim fakültesi ilköğretim bölümü, sınıf öğretmenliği anabilim dalında son sınıfta (7. dönem) öğrenim gören 85 dördüncü sınıf öğrencisinin katılımıyla gerçekleştirilmiştir. Öğretmen adaylarından 59'u bayan 26'sı erkektir. Bu çalışmada, amaçlı örnekleme yöntemlerinden ölçüt örnekleme yöntemi kullanılmıştır. Sınıf öğretmeliği son sınıfta okuyan öğrencilerin seçilmesindeki temel ölçüt, bu öğrencilerin matematik alanı yönünden öğretmenlik mesleğine hazır olmaları, yani genel matematik ve matematik öğretimi derslerini başarıyla geçmeleridir.

Veri Toplama Süreci ve Aracı

Bu çalışmanın amacı doğrultusunda, sınıf öğretmenliği son sınıfta okuyan 85 öğretmen adayına 2013-2014 öğretim yılının güz yarıyılında sınıf ortamında bir anket uygulanmıştır. Anket uygulanmadan önce öğretmen adaylarına anketin amacı, ankette yer alan örnek olay ve açık uçlu soru açıklanmıştır. Anketin süresi yaklaşık 15 dakika sürmüştür.

Anket formunda matematik derslerinde karşılaşılabilecek bir örnek olay ve bir açık uçlu soru bulunmaktadır. Örnek olay Manizade'nin (2006) pedagojik alan bilgisi ile ilgili yaptığı çalışmadan yararlanılarak hazırlanmıştır. Örnek olayda uzunluk ölçümü konusunda öğrencilerin birimleri saymak yerine noktaları saymayı tercih etmelerine dair olan kavram yanılığı kurgulanmıştır. Örnek olaydan sonra öğretmen adaylarının, öğrencilerin kavram yanlışlarını ne derece tespit ettiklerini ortaya çıkarmaya yönelik bir açık uçlu soruya yer verilmiştir. Ankette bulunan örnek olay aşağıda verilmiştir.

İlkokul 4. sınıf öğrencisi Zeynep'ten aşağıdaki soruyu çözmesi istenmiştir.
Aşağıdaki dikdörtgensel şeklin çevresini bulunuz.



Zeynep, şeklin çevre uzunluğunu bulurken aşağıdaki şekilde numaralandırılmış yerleri parmaklarıyla gösterip ve sesli olarak saymıştır. Daha sonra çevre uzunluğunun 16 olduğunu ifade etmiştir.

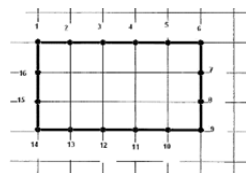

Verilerin Analizi

Bu çalışmada veriler betimsel analize tabi tutulmuştur. Betimsel analiz de veriler daha önceden belirlenen kategorilere göre özetlenir ve yorumlanır. Doğrudan alıntılara yer verilir. Bu tür analizde amaç, elde edilen bulguları düzenlenmiş ve yorumlanmış bir şekilde sunmaktır (Yıldırım ve Şimşek, 2008). Analize öğretmen adayının örnek olayda kurgulanan yanlış yaklaşımın farkında olup olmadığına karar vermekle başlanılmıştır. Eğer öğretmen adayı yanlışlığın farkında ise öğrencinin sahip olduğu kavram yanlışlığını doğru bir şekilde ifade edip etmediği incelenmiştir. Analiz süreci sonucunda öğretmen adaylarının cevapları üç kategori altında toplanmıştır. Bu kategoriler; kavram yanlışlığının farkında olamayanlar, kavram yanlışlığının farkında olup doğru ifade edemeyenler ve kavram yanlışlığının farkında olup doğru ifade edenler.

Araştırmanın Geçerlilik ve Güvenirliği

Bu çalışmada elde edilen ham veriler kategorilere göre tekrar düzenlenerek verinin doğasına sadık kalınarak aktarılmaya çalışılmıştır. Doğrudan alıntılara yer verilmiştir. Bu şekilde çalışmanın geçerliliği sağlanmaya çalışılmıştır (Yıldırım ve Şimşek, 2008). Bu çalışmanın güvenirliliği sağlamak amacıyla araştırmanın aşamaları, veri toplama ve analiz yöntemleri ayrıntılı bir şekilde açıklanmıştır.

BULGULAR

Sınıf öğretmeni adaylarının anketlere verdikleri cevapların kategorilere göre frekans dağılımı aşağıdaki tablo1’de verilmiştir

Tablo 1. Öğretmen Adaylarının Verdikleri Cevapların Kategorilere Göre Frekans Dağılımı

Kategoriler	f	(%)
Kavram yanlışlığının farkında olamayanlar	50	59
Kavram yanlışlığının farkında olup doğru ifade edemeyenler	17	20
Kavram yanlışlığının farkında olup doğru ifade edenler	18	21
Toplam	85	100

Yukarıda verilen tablodan da anlaşıldığı üzere öğretmen adaylarının %59’u öğrencinin kavram yanlışlığını tespit edememişlerdir. Aşağıda öğretmen adaylarının ankete verdikleri cevaplardan örnekler verilmiştir.

Zeynep ilkokul düzeyinde yani somut işlemler döneminde bulunan bir öğrencidir. Bu dikdörtgeni parmağı ile gösterip sesli olarak sayması dikdörtgeni somutlaştırmaya çalıştığının zihinden düşünemediğinin parmakla dokunarak çözüm yolları ürettiğinin bir ispatıdır. Öğrenci bu problemi somutlaştırarak çözmüştür.(ÖA1-Anket)

Zeynep’in soruya verdiği cevap doğrudur. Dikdörtgenin çevresi bana göre 16 cm dir. Zeynep16 cm’yi bulmak için uyguladığı yöntemde gayet başarılıdır.(ÖA2-Anket)

Sonuç doğru olarak bulunduğu için Zeynep’in cevabı doğrudur. Hazır bulunuşluk düzeyi vs dikkate alınırsa somut işlemler döneminde olduğu için sayarak soruyu cevaplandırmıştır. Bu sorunun asıl çözümünde çevre formülünü (2.(3+5)) kullanamamaktadır. Formülü bilme ve onu kullanabilme yeterliğine ileri yaşlarda (sınıflarda) ulaşacaktır.(ÖA3-Anket)

Zeynep’in cevabı doğrudur. Dikdörtgenin cevabı 16’dır. Zeynep’in gidiş yolu da yaşına göre uygun bir cevaptır. Formül kullanmadan kendi ürettiği yolla bulmuştur çözümü. Zaten formülde köşeler sayılarak ortaya çıkarılmıştır. Zeynep’in bu konudaki ön bilgilerinde bir eksik yoktur.(ÖA4-Anket)

Bence doğru. Çünkü dördüncü sınıfa gelen bir ilkokul öğrencisinin matematiksel becerileri daha tam oturmamıştır. Dikdörtgenin iki kenarının karşılıklı eşit olduğunu düşünebilse bile bunu $2A+2B$ şeklinde matematiksel işleme döküp yapması zordur o seviyedeki öğrenci için. Parmakla sayması normal yine de iki kenarın karşılıklı eşit olduğunu bildiği için pratik olarak uzun kenar iki defa, kısa kenar iki defa toplanır şeklinde öğretilmişse öğrencinin parmak hesabı yapmadan yapabileceğini düşünüyorum. Zeynep’in parmak hesabı yaparak soruya yanıt bulmaya çalışması yine sınıfın gelişim düzeyiyle ilgili olabilir. (ÖA5-Anket)

İkinci kategoride ise öğretmen adaylarının % 20'si cevabı yer almaktadır. Bu kategorideki öğretmen adayları öğrencideki kavram yanlışlığını fark etmelerine rağmen kavram yanlışlığını ya yanlış açıklamışlardır ya da hiç açıklamada bulunamamışlardır. Açıklama bulunmayan cevaplarda kavram yanlışlığının olduğu ifade edilmesine rağmen öğrencinin algı biçimi açıklanmamıştır. Aşağıda anketlerden elde edilen verilerden örnekler sunulmuştur.

Zeynep soruyu doğru çözmüştür. Kenarları özdeş ve 1 cm olduğu için cevap doğru çıkmıştır. Anacak aradaki uzaklık 1 cm değil de başka bir şey başka bir şey olsa cevabı yanlış olacaktı. Zeynep'in bulduğu çözüm rastlantı sonucu doğru bulunmuştur. Eğer çevreyi her zaman bu şekilde bulmaya çalışırsa kavram yanlışlığına düşmüş olur. (ÖA6-Anket)

Şeklin çevre uzunluğu $2(a+b)$ ise $a+b=8$ ise $2.8=16$ dır. Zeynep doğru çözmüştür. Ama çözüm yolu yanlıştır. Çünkü numaralandırmak her zaman doğru sonucu vermeyebilir ve uzun zaman alır. Ayrıca numaralandırmaya sol üstten başlaması da ilginçtir. Öğrenci formülü uygulamanın daha zor olduğunu ve sayma kuralıyla doğru cevabı bulabileceğini düşündüğü için böyle yanlışlığa düşmüştür. (ÖA7-Anket)

Zeynep cevabı tesadüfi olarak bulmuş. Noktaları sayarak her zaman doğru bulamaz. Aralıklar 1 cm olmazsa yanlış çıkar. Dikkat problemi yaşıyor. Olguları neden sonuç ilişkisi içinde değerlendiremiyor. Mantık yürütemiyor. Ezberci eğitimle yetişmiş bir çocuk. Parmakları sayarken kullanması öğrencinin görsel zekâsının gelişmediğini gösterir. Gözleri ile saymıyor. (ÖA8-Anket)

Üçüncü kategoride ise öğretmen adaylarının %21'i cevabı yer almaktadır. Bu kategorideki öğretmen adayları öğrencideki kavram yanlışlığını tespit edip doğru bir şekilde açıklamışlardır. Aşağıda anketlerden elde edilen bulgulardan örnekler verilmiştir.

Zeynep bu soruya doğru cevap vermiştir. Ama Zeynep burada sadece noktaları saymıştır. Oysa her iki nokta arası 1 birimdir diyememiştir. Bu yüzden Zeynep bu soruda bir kavram yanlışlığına düşmüştür. Soruyu doğru yanıtlasa bile çözüm yolu yanlıştır. (ÖA9-Anket)

Zeynep bu yöntemle doğru sonuca ulaşmıştır. Fakat cevabı bulurken kullandığı yöntem yanlıştır. Zeynep yaptığı bu yolla noktaları saymış fakat uzunluk noktalar üzerinden değil iki nokta arasındaki mesafeden bulunabilir. Burada Zeynep'in uzunluk konusunda bilişsel olarak eksiklerinin olduğunu söyleyebilirim. Burada öğrenci somut işlem becerisine sahiptir. Matematikteki soyut formülleri bilmiyor olabilir ya da yukarıda belirttiğim gibi uzunluk konusuna dair öğrencide bilgi eksikliği vardır diyebilirim. Bunun yanında eksik ve yanlış öğrenmeler yaşamış ve bu yolla bir kez doğru sonuca ulaştığı için buna benzer her durumda aynı yöntemden faydalanyor olabilir. (ÖA10-Anket)

Zeynep 'in cevabı doğrudur. Anacak noktaları sayarak değil de her bir aralığı sayarak ya da her bir aralığa 1 cm yazarak bulması daha güvenilir bir sonuç çıkartır. Noktaları sayması karıştırmasına neden olabilir. Ayrıca yanlış bir ifade oluşturur. Her bir noktanın uzunluğunun 1 cm olması gibi. Ama aradaki mesafe 1 cm dir. Ön bilgilerinin eksikliğinden kaynaklanmış olabilir. Uzunluk kavramını tam olarak anlayamamıştır. Çünkü soyut bir kavramdır. Somutlaştırılarak anlatılmadığı sürece karışıklık yaşanabilir. (ÖA11-Anket)

Öğrenci küçük karelerin uzunluğundan ziyade noktalara odaklanarak soruyu çözmüştür. Cevap doğru bulmuş ama gidiş yolunda hata var.  yapıp noktaları saymak yerine noktaların arasındaki birimleri saymalıydı. (tabii ki eşit birimler olduğunu kabul ediyoruz) daha sonra aşağıda bir birimin 1 cm olduğunu görerek çevreyi hesaplamalıydı. Bu şekilde bir yolla doğru cevaba ulaşmış ama her yerde ulaşamayabilir. (ÖA12-Anket)

Zeynep'in cevabı kesinlikle yanlıştır. Çünkü birimleri sayması gerekirken noktaları saymıştır. Ve hata yapmıştır. Buda öğrencinin kavram yanlışlığı içerisindedir. Sonucu yanlış yoldan doğru bulmuştur. (ÖA13-Anket)

SONUÇ VE ÖNERİLER

Elde edilen bulgular değerlendirildiğinde, sınıf öğretmeni adaylarının uzunluk ölçme konusunda öğrencilerin kavram yanlışlığını tespit etmekte zorlandıkları söylenebilir. Öğretmen adaylarının büyük bir çoğunluğu, öğrencinin çevre uzunluğunu bulurken kullandığı yanlış yaklaşımı matematiksel olarak analiz edememişlerdir. Öğrencinin ölçülen nitelik, niteliğin miktarı ve birim arasındaki ilişkiyi kuramadığı çoğu öğretmen adayı

tarafından fark edilememiştir. Başka bir ifade ile dikdörtgenin çevre niteliği, çevrenin uzunluğu ve 1 cm olarak verilen birim arasındaki koordinasyon eksikliği öğretmen adayları tarafından teşhis edilememiştir. Uzunluk ölçme konusu perspektifinde sınıf öğretmen adaylarının pedagojik alan bilgisinin bir bileşeni olan öğrenci bilgilerinin zayıf olduğu söylenebilir. Bu sonucun öğretmen adaylarının kendi alan bilgilerinin zayıf olmasından ve öğrenci düşüncelerine yönelik farkındalıklarının yeterli seviyede olmadığından kaynaklandığı düşünülmektedir. Bu yüzden sınıf öğretmeni adayları kendi alan bilgilerinden hareketle öğrencilerin algı biçimlerini yorumladıkları söylenebilir. Elde edilen bu sonuç literatürle de paralellik göstermektedir. Van Driel ve arkadaşları (1998), öğretmenlerin konu alan bilgileri yeterli olduğu durumlarda, öğrencilerin kavram yanılgılarının daha kolay fark edilebildiğini ileri sürmüştür.

Araştırma sonuçlarına dayalı olarak aşağıdaki öneriler sunulabilir;

- Sınıf öğretmenliği lisans programlarında, öğretmen adaylarının öğrencilerdeki kavram yanılgılarının neler olduğunu, bunların sebeplerinin neler olabileceğini ve bu kavram yanılgıların giderilmesi hususunda neler yapılabileceğine ilişkin öğretim faaliyetlerine yer verilmelidir.
- Sınıf öğretmeni adaylarının öğretmen olduklarında sınıf ortamlarında karşılaşılabilecekleri kavram yanılgıları anket formunda yer alan örnek olaylar gibi kurgulanıp matematik öğretimi derslerinde ayrıntılı bir şekilde tartışılabilir. Bu sayede hem öğretmen adaylarının sınıf ortamına girmeden öğrenci algı biçimlerine karşı tecrübe kazandırılabilir hem de bu kavram yanılgılarına sahip öğretmen adaylarının kendilerini düzeltmelerine fırsat verilmiş olur.

KAYNAKLAR

- Barrett, J. E., Jones, G., Thornton, C., Dickson, S. (2003). Understanding children's developing strategies and concepts for length. D.H. Clements ve G. Bright (Eds.), *Learning and Teaching Measurement 2003 Yearbook* (s. 46-57). Reston,VA: NCTM.
- Battista, M. T. (2006). Understanding the development of students' thinking about length. *Teaching Children Mathematics*, 13(3), 140-146.
- Boulton-Lewis, G. M., Wilss, L. A., ve Mutch, S. L. (1996). An analysis of young children's strategies and use of devices for length measurement. *Journal of Mathematical Behavior*, 15, 329-347.
- Emekli, A. (2001). *Ölçüler Konusunun Öğretiminde Yanılgıların Teşhisi Ve Alınması Gereken Tedbirler*. Yayınlanmamış Yüksek lisans Tezi, Selçuk Üniversitesi, Konya, Türkiye.
- Manizade, A. (2006). *Designing Measures for Assessing Teacher's Pedagogical Content Knowledge of Geometry and Measurement at the Middle School Level*. Yayınlanmamış Doktora Tezi, University of Virginia.
- MEB (2009). *Talim ve Terbiye Kurulu Başkanlığı, İlköğretim Matematik Dersi 1-5. Sınıflar Öğretim Programı*. Ankara: MEB Basımevi.
- Şişman, G. ve Aksu, M. (2009). Yedinci Sınıf Öğrencilerin Alan ve Çevre Konularındaki Başarıları. *İlköğretim Online Dergisi*, 8 (1), 243-253. [Online]: Retrieved on 3-January-2011, at URL: <http://ilkogretimonline.org.tr/>
- Van De Walle, John A., Karp, Karen S., Bay-Williams, Jennifer M. (2012). *İlkokul Ve Ortaokul Matematiği Gelişimsel Yaklaşımla Öğretim*, (Çev. Edit. Soner Durmuş), Ankara: Nobel Akademik Yayıncılık.
- Van Driel, J. H., Verloop, N., De Vos, W. (1998). Developing Science Teachers' Pedagogical Content Knowledge. *Journal of Research in Science Teaching*, 35 (6), 673-695.
- Yıldırım, A., Şimşek, H. (2008). *Sosyal Bilimlerde Nitel Araştırma Yöntemleri*. (7. Baskı). Ankara: Seçkin Yayıncılık.
- Zembat, İ. Ö. (2009). Ölçme Temel Bileşenleri ve Sık Karşılaşılan Kavram Yanılgıları., M. F. Özmantar, E. Bingölbali, (Editörler). *İlköğretimde Karşılaşılan Matematiksel Zorluklar ve Çözüm Önerileri*. Ankara: Pegem Akademi.

EXAMINING THE CONCEPT CARTOONS BY PRE-SERVICE PRIMARY SCHOOL TEACHERS

Şule BAYRAKTAR
Necmettin Erbakan University
sulebayraktar@yahoo.com

ABSTRACT: In this study, examples of concept cartoons created by pre-service primary teachers related to certain science topics were presented. The concept cartoons created by student-teachers were examined in terms of topics they were related to, type of the characters, forms of expressions in presenting different claims of the characters. Results of the study showed that student-teachers were well aware of the misconceptions that primary school students might have posses in various science subjects and they have gained adequate skills to create appropriate concept cartoons to diagnose these misconceptions.

Keywords: Concept cartoons, science teaching, pre-service primary teachers, misconceptions

INTRODUCTION

Concept cartoons are one of the most effective tools that can be used to detect students' misconceptions. Concept cartoons, unlike regular cartoons are not for humor purposes. Concept cartoons were created in 1992 for instructional purposes and based on the dialogs of cartoon characters (Keogh & Nylor, 1999). Generally they involve three or more characters which might be human, animal or non living things. Each one of these characters presents an idea about a scientific phenomenon. At least one of these ideas indicates a misconception, one presents the scientific idea and the ideas of other characters might be scientific or nonscientific ideas. Students are introduced with the cartoons and they are asked which character they are agree with. Students' conceptions or misconceptions can be identified by examining the ideas of the character which s/he indicated that s/he is agreed on.

Concept cartoons have a special place in especially science education since that they can relate sophisticated scientific concepts with the situations which we encounter in everyday life. They can be considered as practical visual instructional tools which are very effective in attracting students' attention and creating curiosity. Besides motivating students, concept cartoons can be used to initiate discussion during the class session, to give students feedback. They can also be used as an alternative assessment tool.

The main phases of the instruction with concept cartoons are: a) introducing the cartoon to students, b) Discussion of the ideas that the cartoon characters proposed c) Inquiry process d) re-evaluating the ideas proposed by the cartoon characters in the light of the data obtained during the inquiry process.

Students' misconceptions can be changed by means of discussion and cognitive processes which was initiated by concept cartoons (Andrews, Kalinowski, and Leonard, 2011) Concept cartoons do not tell students which idea is correct. For this reason, they can stimulate students' thought process which might lead them to question their existing ideas and as a result change the incorrect ideas and construct scientific conceptions as well as increasing their motivation for the lesson to be taught. (Keogh & Naylor, 1996; Long & Marson, 2003).

In the literature, there are many studies focusing on the effects of concept cartoons in different educational levels in Turkey (Demir, 2008 ; İnel, Balım & Evrekli, 2009; Kabapınar, 2005; Oluk & Özalp, 2007) and in the world (Keogh & Naylor, 1999; Morris, Merritt, Fairclough, Birrell, and Howitt, 2007; Chin & Teou, 2009). The cartoons found to be an effective tool in teaching of various subjects (İnel & Balım, 2013; Gölgeci & Saracoğlu, 2011; Perales-Palacios & Vilchez González, 2005) and overcoming misconceptions (Ekici, Ekici & Aydın, 2007). Concept cartoons are also practical as an alternative assessment tool (Kandil-İnceç, 2008; Naylor, Keogh, & Downing, 2007; Song, Heo, Krumenaker, & Tippins, 2008; Şaşmaz-Ören & Ormancı, 2011).

METHOD

The purpose of this research presents a different aspect from the research done previously in this area. This research examines the concept cartoons drawn by pre-service primary teachers in some respects. The researcher is an academician who works in a teacher training institute with primary education majors. In the science methods course which she instructs, first she introduced the concept cartoons to the primary education students. The instructor then, showed sample concept cartoons to the class and allow them to examine the cartoons in detail. Then, she presented the techniques on how to use concept cartoons during the instructional process and performed a sample lesson. Primary Education majors were aware of the misconceptions that primary school children's might possess in several science subjects, since they have examined the primary school curriculum already and they have identified the most common misconceptions of children of these grades. Afterwards, pre-service primary teachers were asked to prepare concept cartoons which were related to one subject of their preference which takes place in the primary school science curriculum. They were given time as much as they desire, the completed concept cartoons gathered together and examined regarding different aspects of them.

The sample of this study consisted of 49 concept cartoons. Concept cartoons drawn by pre-service primary teachers were analyzed by using categorical content analysis. This technique of content analysis is not restricted to textual analysis, but may be applied to other areas such as coding student drawings (Stemler, 2013).

Concept cartoons were examined in terms of: a) the subjects they were related to b) type and the number of the characters c) forms of expression they used to present the misconceptions. The results obtained by examination of the cartoons according to the designated categories are presented in the following section.

RESULTS

A. Examination of Cartoons by Subjects

Table1. Cartoons by Subject

Teaching Unit (Subject)	f (%)
Living Things	20(40.8)
Matter and Change	10(20.4)
Earth, Sun & Moon	9(18.36)
Light & Sound	3(6.12)
Electricity	4(8.16)
Others	3(6.12)
Total	49(100)

Most of the student teachers' concept cartoons (40.8%) were related to living things teaching unit. Second popular subject was Matter and Change teaching unit (20.4%) followed by Earth and the Space(18.6%). There were fewer cartoons related to other subjects in science curriculum. It was especially noteworthy that there was only one cartoon related to force and movement unit.

B. Examination of Cartoons by Character Type

Table 2. Cartoons by Character Type

Character Type	f(%)
Human	29(59.18)
Animal	9(18.36)
Nonliving things	6(12.24)
Combination	5(10.20)
Total	48(100)

When the characters examined, it is seen that student teachers mostly chose to draw human characters and most of them had 3 characters (n= 24) and others 4 or more (n=5). Some drawings contained animal characters (n=9). Examining the drawings it was seen that those drawings with animal characters were related to the topic of

habitats and classification of animals. The other characters such as plants and nonliving things were chosen concordant with the topic of misconceptions.

C. Examination of Cartoons by Form of Expression

Table 3. Cartoons by Form of Expression

Form of Expression	f (%)
Personification	17(34.69)
Dialog (Direct expression)	13 (26.53)
Express in a Story -or using real life examples	19(38.77)
Total	49(100)

1. Personification: In 17 of the 49 cartoons animals, plants and nonliving things (earth, sun, moon, cars, other objects) were made to talk. In these cartoons the student teachers preferred to use the specific objects of the examined phenomena instead of humans as actors. These cartoons were mostly about Earth and Space, classification of the animals, habitats, and properties of living things and matter.

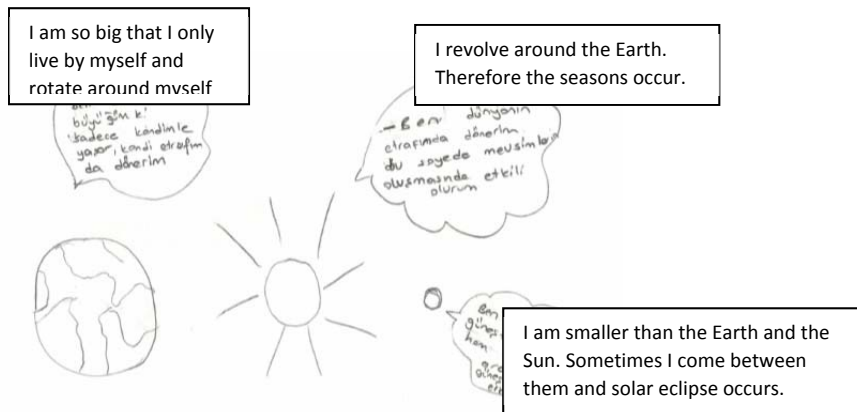

2. Dialog (Direct Expression): Direct expression or dialog of people were chosen as a form of expression for presenting misconceptions which were related to the following topics: evaporation of liquids (n=2), electricity (n=2), shape of the Earth (n=1) Respiration of plants (n=1) Matter (n=2), Movements of the Sun, Earth and Moon (n=3) Classification of animals (n=2).

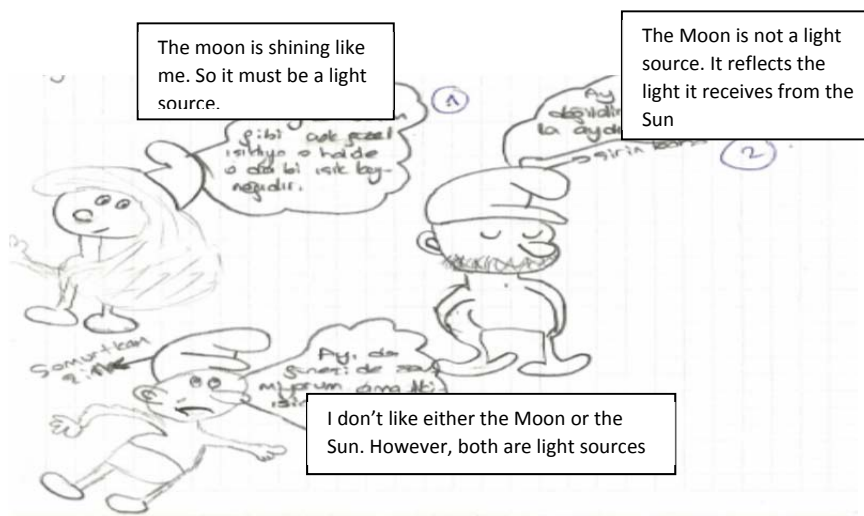

3. Generating a story or relating the real life examples. Student teachers used stories or real life examples especially for the topics of matter and change teaching unit such as: evaporation (n=1), mass conservation (n=2) Impurities-boiling point (n=1) granular solids (n=1) properties of living things (n=1), Elevation-temperature relation (n=1).

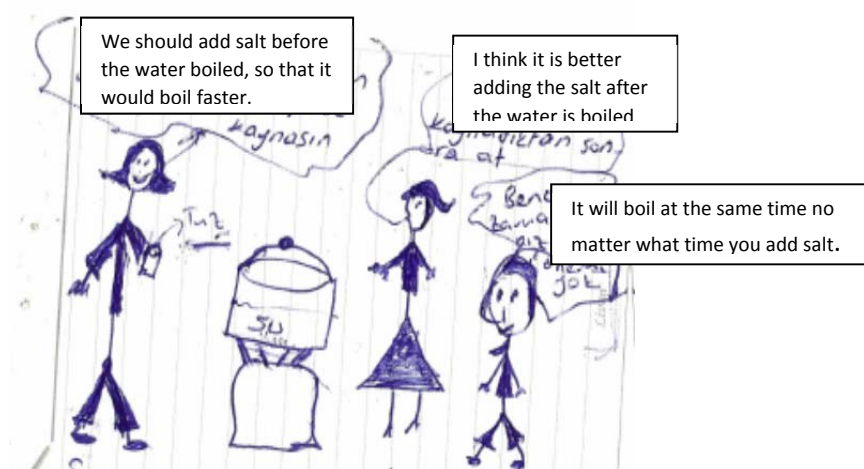

DISCUSSION

The examination of the concept cartoons created by student-teachers revealed that they were aware most of the misconceptions that their future students might have possess. Student teachers created fewer concept cartoons for some teaching units especially “force and movement” and “light and sound”. The reason for that might be there were fewer misconceptions reported in the literature on these specific topics and the content of them were relatively less than the other topics in primary science curriculum in Turkey. However, it is also possible that student teachers might not aware of the misconceptions peculiar to those topics. However, since student teachers decided themselves on the topics of the cartoons they draw, it is not possible to know the reason for their not drawing cartoons about some particular topics. They might also have difficulties about how to express the misconceptions about certain topics, so they did not chose to draw cartoons about those topics. An interview with the student teachers might have shed light on this issue.

Results of this study also showed that student teachers were well aware of the function and elements of a concept cartoon. Except for three of them, all the concept cartoons possess all the qualities that a concept cartoon must have. Furthermore, student teachers were successful in using appropriate expression forms for their cartoons which is compatible wit the subject they chose. They insert their cartoons in a story or present real life examples to make abstract concepts more concrete. It is also remarkable that student teachers added various contents in the background of their drawings which are highly related to the subject, such as a container filled with water on fire in the cartoon about boiling point; and the natural environment around the animals in the cartoon about the habitats.

CONCLUSION

A comparison with earlier studies cannot be made for this study since it is one of the firsts. However, the result of the study is significant. Student teachers’ concept cartoons showed that they were aware of the misconceptions in various topics of the science curriculum and that they gained the skills to create a concept cartoon which is one of the most effective tools for diagnosing students’ misconceptions. To create concept cartoons correctly, student-teachers should be knowledgeable about the misconceptions of students as well as the elements and the properties of a concept cartoon itself. Student teachers’ creating their own concept cartoons could be a beneficial practice in science methods courses.

REFERENCES

- Andrews, T.M., Kalinowski, S. T. & Leonard, M. J.(2011). Are humans evolving? A classroom discussion to change student misconceptions regarding natural selection. *Evolution: Education and Outreach* 4, 3, 456-466.
- Chin, C. & Teou, L.(2009) Using concept cartoons in formative assessment: Scaffolding students' argumentation. *International Journal of Science Education*, 31,10, 1307-1332.
- Demir, Y.(2008). Kavram yanlışlarının belirlenmesinde kavram karikatürlerinin kullanılması. Yüksek Lisans Tezi, Fen Bilimleri Enstitüsü, Atatürk Üniversitesi, Erzurum.
- Ekici, F., Ekici, E., & Aydın, F.(2007). Utility of concept cartoons in diagnosing and overcoming misconceptions related to photosynthesis. *International Journal of Environmental and Science Education*, 2, 4, 111-124.
- Gölgeli, D. & Saracoglu, S.(2011). Fen ve Teknoloji Dersi Işık ve Ses ünitesinin öğretiminde kavram karikatürlerinin kullanımının öğrencilerin akademik başarısına etkisi, *Erciyes Üniversitesi Sosyal Bilimler Enstitüsü Dergisi*, 31, 113-124.
- İnel, D., Balım, A.G. & Evrekli, E.(2009). Fen öğretiminde kavram karikatürü kullanımına ilişkin öğrenci görüşleri.. *Necatibey Eğitim Fakültesi Elektronik Fen ve Matematik Eğitimi Dergisi* 3,1, 1-16.
- İnel, D. & Balım, A. G. (2013). Concept cartoons assisted Problem Based Learning Method in Science and Technology teaching and students' views. *Procedia-Social and Behavioral Sciences*, 93, 376-380.
- Kabapınar, F. (2005). Yapılandırmacı öğrenme sürecine katkıları açısından fen derslerinde kullanılabilecek bir öğretim yöntemi olarak kavram karikatürleri. *Kuram ve Uygulamada Eğitim Bilimleri*, 51, 101-146.
- Kandil-Ingec, S.(2008). Use of concept cartoons as an assessment tool in physics education. *US- China Education Review*, 5, 11.
- Keogh, B. & Naylor, S.(1996). Teaching and learning in science: A new perspective. *Lancaster: British Educational Research Association Conference*.
- Keogh, B. & Naylor, S.(1999). Concept cartoons, teaching and learning in science: an evaluation, "*International Journal of Science Education*, 21(4), 431-446.
- Larkin, D.(2012). Misconceptions about "misconception: Pre-service secondary science teachers' views on the value and role of student ideas. *Science Education*, 96, 5, 927-959.
- Long, S. & Marson, K.(2003). Concept cartoons. *Hands on Science*, 19, 3, 22-23.
- Morris, M., Merritt, M., Fairclough, S., Birrell, N. & Howitt, C.(2007). Trialing concept cartoons in early childhood teaching and learning of science. *Teaching Science*, 53(2), 42-45.
- Naylor, S., Keogh, B. & Downing, B.(2007). Argumentation and primary science. *Research in Science Education*, 37, 1, 17-39.
- Oluk, S. & Ozalp, I.(2007). The Teaching of Global Environmental Problems According to the Constructivist Approach: As a Focal Point of the Problem and the Availability of Concept Cartoons. *Educational Sciences: Theory and Practice* 7, 2, 881-896.
- Öztuna-Kaplan, A. & Boyacioglu, N.(2013). Granular structure of the substance in the children's cartoons. *Journal of Turkish Science Education*, 10, 1, 156-175.
- Perales-Palacios, F. J. & Vilchez-González, J. M. (2005). The teaching of physics and cartoons: Can they be interrelated in secondary education? *International Journal of Science Education*, 27, 14, 1647-1670.
- Sasmaz-Oren, F. and Ormanci, U. (2011). Teacher candidate levels of familiarity with the methods, techniques and tools composing the alternative assessment approaches. *Procedia-Social and Behavioral Sciences* 15, 3476-3483.
- Song, Y., Heo, M., Krumenaker, L. & Tippins, D.(2008). Cartoons: An Alternative learning assessment. *Science Scope*, 31,5, 16-21.
- Stemler, S.(2013). An overview of content analysis. *Practical Assessment Research & Evaluation*, 7(17). Retrieved December 9, 2013 from <http://PAREonline.net/getvn.asp?v=7&n=17>

THE EFFECT OF INFORMATION TECHNOLOGY IN TEACHING PHYSICS COURSES

Zahra Habibi
Department of Education Ardebil Iran
Za.hb.ye@gmail.com

Ali Habibi
Department of Computer Razi University Ardebil Iran
a.habibi.y@gmail.com

ABSTRACT: In this study, we investigated the effect of information technology in teaching physics course, in students. In order to prove this claim, we design a questionnaire consisting of 12 questions. The gathered answers from student were categorized as “right”, “wrong” and “no responded”. Survey of 150 students from high school in qualitative and quantitative is performed. Also we considered scores of physics course in previous and later of use information technology in teaching for related students as parameter in evaluation research. For enhance the accuracy of these questionnaires we were interviews with 25 students. The result of this investigation, show that there is Significant relationship between information technology and teaching physics courses. Based on the results obtained from this study suggestion were presented to enhance use of information technology.

Key words: Information Technology, teaching physics course

INTRODUCTION

Information technologies in education refer to teaching and learning the subject matter that enables understanding the functions and effective use of Information and Communication Technologies (ICTs)[1-2]. As of 2004, a review and the literature on teaching ICT[3] as a subject implied that there was limited, systematically-derived, quality information. In order to use technology effectively, educators need to be trained in using technology and they need to develop a good understanding of it. Information Technology[4-5] is used to enhance learning; therefore it is important for educators to be comfortable using it to ensure that students get the full advantages of educational technology. Teaching with technology is different from teaching in a typical classroom. Teachers must be trained in how to plan, create, and deliver instruction within a technological setting. It requires a different pedagogical approach. Teachers must find a way to assess students on what they take away from a class and meaningful, known knowledge, especially within an eLearning setting. Education will only change when our design methods, perspectives, and values change. Teachers have many roles when instruction is designed. They can be artists, architects, craftspeople, and engineers. Technology does not mean that using interactive electronic boards and LCD PowerPoint presentation is the most effective. So many more applications are available for students to be hands-on with their learning and gain deeper knowledge than they could before. Technology training appears to focus mainly on technology knowledge and skills while overlooking the relationships between technology, pedagogy, and content. As a result, teachers learn about “cool” stuff, but they still have difficulty applying it for their students’ learning. Teacher candidates need opportunities to practice effective technology integration strategies in supportive contexts during technology courses, technology-integrated methods courses, and field experiences. Experienced teachers also need opportunities to learn about new technologies and ways to integrate them effectively in their classroom. Teacher education programs can facilitate improvements not only in students’ technology skills but also in their beliefs and intentions regarding integrating technology into instruction. Technology training directly affects pre-service teachers’ self-efficacy and value beliefs, which in turn influence their student-centered technology use.

However, physics as a science oriented course or discipline is known for its abstract nature (having nonmaterial existence). Sometimes the physics teacher does not have adequate knowledge, but have to fall on ideas which lead to contradictions with what the physics theory says or meant. Students are left on their own, even when they are to read on their own, they find no material to read, where it is available most of them are obsolete material. That is, some of these materials include textbook, journals, research publications and news papers e.t.c. where these materials are lacking the students are forced to lose interest, motivation and passion; in some cases frustration sets in and students abandon the discipline or subject matter (physics) for another which they can cope with i.e.

students leaving science class because of physics to commercial or Art subjects, simply point to the fact that other disciplines are not abstract in nature like that of physics. However, physics is a unique subject, which promotes the acquisition of specialized science skills and Knowledge, which explain the natural phenomena of life in the society. It is a subject that grew up with civilization as man's quantitative needs increased. It arose out of practical problems and mans need to solve these problems. It has contributed to the development of the sciences and to the development of civilization. Despite the abstract nature of physics its teaching is to bring about scientific thinking in students; a mindset that requires students to test out, through experimentation. However, through the use of IT, whether CD-Rom, power point, etc the teaching and learning of physics is interesting.

Information Technology in physics teaching

Schools' access to Information and communication Technologies (ICT)[7] poses tremendous challenges to physics teaching and learning. Physics is one of the first areas where the possibilities that computers may offer for the employment of new teaching methods have been and are still explored. A variety of computer applications have been developed and used in teaching Physics, such as computer-based laboratories, multimedia, simulations and intelligent tutors. Furthermore, research has often been employed to direct educational software design and development. Today numerous IT applications are available, aiming to stimulate students' active and offering the opportunity to work under conditions that are extremely difficult, costly or time-consuming to be created in the classroom or even the physics lab. The use of such IT applications has developed a new research field in physics education. Among the various IT applications, Information Technologies are of special importance in Physics teaching and learning. Information Technologies offer new educational environments, which aim to enhance teachers' instructional potentialities and to facilitate students' active engagement. IT offers a great variety of opportunities for modeling concepts and processes [8-9]. IT provides a bridge between students' prior knowledge and the learning of new physical concepts, helping students develop scientific understanding through an active reformulation of their misconceptions [10]. Specifically, they are developing their understanding about physical laws through a process of hypothesis-making, and ideas testing and isolate and manipulate parameters and therefore helping them to develop an understanding of the relationships between physical concepts, variables and employ a variety of representations (pictures, animation, graphs, vectors and numerical data displays) which are helpful in understanding the underlying concepts, relations and processes and express their representations and mental models about the physical world investigate phenomena's which are difficult to experience in a classroom or lab setting because it is extremely complex, technically difficult or dangerous, money-consuming or time-consuming, or happen too fast.

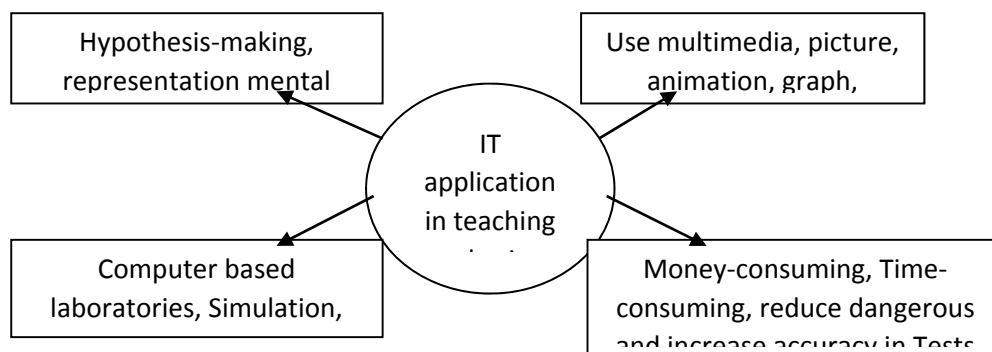

Figure 1. IT Applications in teaching physics course

Today a wide variety of educational software is available for teachers and students helping them to present and model physical phenomena and processes, or solve physics problems. Computer simulations have been successfully applied from high school to university physics teaching. They have been used to diagnose and remedy alternative conceptions of velocity, and confront alternative students' conceptions in mechanics. A recent study showed that simulations were equally effective to micro-computer based labs in facilitating the comprehension of concepts involving the free fall of objects. Other studies focus on the effects of the use of computer simulations on students' conceptual understanding. Information technology (IT) is concerned with the use of technology in large organizations .In particular, IT deals with the use of electronic computers and computer software to convert, store, protect process, transmit and retrieved information.

METHODS

Purpose of study

This study investigated the effect of IT on teaching and learning of physics course and found out whether students were taught physics with the use of IT materials such as computer system, internet facilities, projector, video player and etc performed better than those taught with textbook and traditional teaching.

Research hypothesis

Information Technology has effect in improving the students learning and knowledge in physics.

Participants

150 high school students, who were attending a physics course in Iran, participated in the study. This physics course is teaching in three hour per week. Of the 150 students. Our research was carried out during the academic year 2011-2013 and took place about 5 months after students had received school teaching on basic physics concepts. Physics is the first teaching topic described in the Iran Ardebil high school Curriculum.

The educational intervention

Our educational intervention took place approximately one year after students in the experimental group had received traditional classroom teaching on the relevant topics. All students from the experimental group were offered two 2-h lessons in the Information Technology lab. During the year lesson the teacher, with the collaboration of a researcher. Furthermore, all students had a short period of practice in order to familiarize with the Information Technology environment.

During the lesson students were engaged in tasks demanding the use of Interactive Physics representations. They also used the simulation software to represent various physical quantities in graphical form, understand the relationships between physical concepts and, finally, to develop an in-depth understanding of the physical laws. Students in the experimental did not use other Technology to experiment with other types of trajectory in physics course.

Instrument

Data were collected using two basic instruments namely: Information Technology Effect on Teaching Physics course (ITETP) the instrument was a structured questionnaire. The ITETP was used to collect information on respondents' Quantitative –Information Technology Effect on Teaching (QITET).

This measurement tool can be used for finding out the high education school students' about their physics problem with use of Information Technology. After implementation of the inventory to 150 students from different classes (2th,3th, 4th) compare result of inventory, The results are presented in the table 2.

Qualitative – Focus Interview

After completion of the implementation of the inventory, teachers choose twenty five students from classes according to their interest and success with Information Technology. One of the researchers conducted a focus group interview with a structured interview form. The questions below were asked to the students:

Did you have difficulty with the Information technology?

How much IT has been effective in the process of doing physics experiments?

Is the IT accurate than the traditional approach of physics experiments?

What was your favorite aspect of Information technology?

Do you like teaching with Information technology?

Do you use information technology in your interest towards physics has been effective?

Of the 25 students who participated to the focus group interview, 12 were female and 13 were male.

Context and Process

The research tool was a questionnaire based on open-ended questions. This questionnaire was administered to all students in using Information Technology Effect on Teaching (ITFT). Students were asked to answer questions based on descriptions of the tasks and provide the necessary justifications to their responses. In particular, the students were asked to evaluate qualitatively the experimental processes of the tasks. The

questionnaire included questions concerning the concepts of topics physic field. The questions focused on two parameters: before use of Information Technology and the use of the Information Technology in teaching physic course. The statistical treatment of data collected was analyzed using statistical packages for social science (SPSS) and these include: Simple percentages Chi – Square. In compliance with a pre –study of the instrument was carried out and tested with Cronbach alpha coefficient and a reliability coefficient of 0.91 was obtained, which showed a strong reliability of the research instrument.

RESULTS AND FINDINGS

Data analysis

The data analysis and results are presented with special reference to the research two hypotheses in the use of the IT study. Student-based research group, and the status of the problem is properly assessed, measured in accordance with Table 2 were designed based on this table were analyzed.

Table 1. Show respond for questionnaire

Respond
Empty (E)
Right (R)
Wrong (W)

H0: Information Technology will not have any significant impact on teaching and tear ling of physics.

In testing the above hypothesis, Chi-square statistics was adopted using question asked to ascertain the use of IT in enhancing teaching and learning of physics. The results are presented in the table below:

Table 2. ICT will not have any significant effect on teaching and learning of physics

Respond	observed	Expected
R	13	50
W	135	50
E	2	50
Total	150	150

$$\chi^2=217.96 \quad df=2 \quad Sig=.000$$

According to table2, $\chi^2=217.96$, $df=2$ and $p<.01$ show that participants believe that ICT has positive effect on teaching and learning of physics.

CONCLUSION

If our schools throughout the country are to maintain maximum educational standards, they should be Provided with adequate funds, infrastructural facilities in terms of modern classrooms equipped with electronic computer system which are connected to internet, well equipped laboratories, workshops, Libraries, instructional materials and highly qualified personnel that can effectively utilize these resources. With the introduction of information and communication Technology, a new challenge for science and physics education has emerged.

Information Technology is significant because it is necessary for the development of our educational system. Therefore, there is no doubt that the world are in the grip of a telecommunications resolution. This means that we are at the advantage to develop our educational system to meet the demand of other developed countries. So the need for information Technology is of great advantage for our schools. Schools should be introduced to IT so that government will pay more attention to educational system of the country and provide necessary support to the growing trend of education to meet the standard of the developed countries.

Finally, our high school students should be given the best in education with modem facilities which will in turn draw out the best in every student and ensures the utility of these students to the development of Iran and the world at large.

RECOMMENDATION

The major focus of the study was actually to evaluate the Effect of Information Technology on teaching and learning of physics in our high schools. Based on this investigation, it is considered very important to make the following recommendations:

1. Government should encourage attracting state, local, international bodies and Non-governmental organizations to invest on IT related projects in secondary and high schools.
2. IT equipment and facilities such as internet, and equipment of IT should be made available to all secondary and high schools.
3. Only qualified and competence physics teachers should be have skills in using information technology to teach physics course in classrooms.
4. Physics teachers should be encouraged to study further in the IT.
5. Attention should be paid of facilities in our secondary and high schools. Also ICT system together with necessary peripherals should be bought. This will enhance the teaching and learning of physics and allow discovery of more facts.
6. Conferences, seminars and workshops and relevant programs should be organized by professionals of IT to teach physics teachers and science teachers on modern technology and its uses.
7. IT relevant curriculum should be developed specially for primary schools, secondary schools and institutions.
8. Establishing facilities for electronic distance learning networks opportunities in our schools.
9. Creating IT Application, in Research Design and Development strategy.

REFERENCES

- [1] Athanassios jimoyiannis, (2001). Computer simulations in physics teaching and learning: a case study on students' understanding of trajectory motion, computer and education36.
- [2] McFarlane, A., Sakellariou, S., (2002). The role of ICT in science education. *Cambridge Journal of Education*, 32 (2), pp.219-232.
- [3] Mistier - Jackson, M., songer, N.B., (2000). Student motivation and -internet technology: Are students empowered to learn science? *Journal of Research in Science Teaching*, 37 (5), pp. 459-479.
- [4]Hake, R. R. (1998). Interactive-engagement versus traditional methods: A six-thousand-student survey of mechanics test data for introductory physics courses. *American Journal of Physics*, 66(1), 64-74.
- [5]Kiboss, J. K. (2002). Impact of a computer-based physics instruction program on pupils' understanding of measurement concepts and methods associated with school science. *Journal of Science Education and Technology*, 11(2), 193-198.
- [6]Linn, M. C. (1985). The cognitive consequences of programming instruction in classrooms. *Educational Researcher*, 14(5), 14-29.
- Martín-Blas, T., & Serrano-Fernández, A. (2009). The role of new technologies in the learning process: Moodle as a teaching tool in physics. *Computers & Education*, 52(1), 35-44.
- [7] Murphy, C., (2003). Literature review in primary Science and ICT. NESTA Futurelab Series, Bristol: NESTA Futurelab. <http://www.Nestafuturelab.org/research/reviews/psi01.htm>.
- [8] Osborne, J., Hennssy, S., (2003). Literature review in science education and the role of ICT: Promise, problems and future directions. NESTA Futurelab series, Bristol: NESTA Futurelab. <http://www.nestafuturelab.org/research/reviews/se01.htm>.
- [9] Wetzal, D.R., (2001). A Model for pedagogical and curricula Transformation for the Integration of Technology in Middle School Science. Paper presented at the Annual Meeting of the National Association for Research in Science Teaching, St. Louis, MO, March 25-28. <http://facstaff.bloomu.edu/dwetzal/pdffiles/NARST2001paper.pdf>.
- [10] Yerrick, R., Hoving, T., (1999). Obstacles confronting technology initiative as seen through the experience of science teachers: A comparative study of science teachers' beliefs. Planning, and practice. *Journal of Science Education and Technology*, 8 (4), pp.291-307.
- [11] Aladejana, F. (2000). The Implications of ICT and NKS for science Teaching; Whiter Nigeria? Institute of Education, faculty of Education Obafemi Awolowo University Ile-Ife, Nigeria.
- [12] Busari (2006). Effective teaching and learning of Science

MADDENİN PARÇACIKLI YAPISI İLE İLGİLİ KAVRAM YANILGILARININ GİDERİLMESİNDE MODELE DAYALI AKTİVİTELERİN ETKİSİ

Ayşegül ERGÜN
MEB Denizli Milli Eğitim Müdürlüğü
ergunaysegul@gmail.com

Mustafa SARIKAYA
Gazi Üniversitesi
sarikaya@gazi.edu.tr

ÖZET: Literatürde yer alan Fen Eğitimi araştırma sonuçlarına göre, ilköğretimden üniversite seviyesine kadar çok sayıda öğrenci, maddenin parçacıklı yapısı ile ilgili kavramları öğrenmede zorluk çekmektedir. Buna bağlı olarak öğrencilerde atom ve molekül kavramları ile ilgili yanlış kavramalar oluşmaktadır. Böylece bu iki temel kavram üzerine kurulmuş olan diğer kavramlar da tam olarak anlaşılmamaktadır. Maddenin parçacıklı yapısını oluşturan atom ve moleküller ile ilgili kavram yanlışlarının aşılması, Fen Bilimleri öğretiminin sağlıklı olarak yapılabilmesi açısından büyük önem taşımaktadır. Bir fen öğretmenin, bir fen eğitimcisinin öğretimde başarılı olabilmesi, büyük ölçüde, öğrencilerinin neleri kavramakta zorluk çektiğinin farkına varmasına bağlıdır. Aynı zamanda öğrencilerinin var olan kavram yanlışlarının iyileştirilmesi için uygun öğretim ortamları hazırlayarak, uygun yöntem ve teknikler kullanılmalıdır. Fen eğitiminde yer alan maddenin parçacıklı yapısı kavramı, öğrencilerin duyu organları ile algılayamadıkları soyut bir kavramdır. Bu kavramın öğretiminde modele dayalı aktivitelerin kullanılması, öğrencilerin zihinlerinde kavramı somutlaştırmaları ve var olan kavram yanlışlarının giderilmesi açısından önemlidir. Bu çalışmanın amacı ilköğretim öğrencilerinin maddenin parçacıklı yapısıyla ilgili başarı düzeylerini belirlemek ve bu konudaki öğrenme zorluklarını (kavram yanlışlarını) iyileştirmek için, modele dayalı aktivitelerin etkisini araştırmaktır. Çalışma, karşılaştırmalı nicel geriye dönük bir araştırmadır. Çalışmada tarama modeli ve tek grup öntest-sontest modeli kullanılmıştır. Araştırmanın tarama grubunun örneklemini 278 ilköğretim öğrencisi, deney grubunun örneklemini ise 166 ilköğretim öğrencisi oluşturmaktadır. Evreni, araştırmanın yapıldığı ders yılında 4-8 sınıflarındaki toplam öğrenciler oluşturmaktadır. Veriler, Maddenin Parçacıklı Yapısı Kavram Testi (MPYKT, $\alpha = .79$) ile toplanmıştır. Deney grubuna MPYKT öntest olarak uygulanmış, ardından modele dayalı aktivitelere dayanan ders anlatımı yapıldıktan sonra MPYKT son test olarak uygulanmıştır. Araştırmanın hipotezleri, SPSS 10.0 programı kullanılarak İlişkili Örneklem t-Testi, İlişkisiz Örneklem t-Testi ve tek faktörlü varyans analizi ile test edilmiştir. Kestirel istatistik sonuçları, betimsel analiz sonuçları ile de desteklenerek sunulmuştur. Sonuç olarak öğrencilerde maddenin parçacıklı yapısı ile ilgili var olan kavram yanlışlarının giderilmesinde, modele dayalı aktivitelerin başarılı olduğu görülmüştür.

Anahtar sözcükler: modele dayalı aktiviteler, kavram yanlışlığı

BECERİ TEMELLİ ELEŞTİREL DÜŞÜNME EĞİTİMİNİN İLKOKUL 3. VE 4. SINIF ÖĞRENCİLERİNİN ELEŞTİREL DÜŞÜNME BECERİLERİNİ GELİŞTİRME DÜZEYİNE ETKİSİ

THE EFFECTS OF SKILL-BASED CRITICAL THINKING EDUCATION ON THE LEVELS OF DEVELOPING CRITICAL THINKING SKILLS OF 3RD-4TH GRADE PRIMARY SCHOOL STUDENTS

Yahya KORKMAZ
Fen ve Teknoloji Öğretmeni

Doç. Dr. Özgül KELEŞ
Aksaray Üniversitesi Eğitim Fakültesi
ozgulkeles@aksaray.edu.tr

ÖZET: Bu çalışmada, ilkokul 3-4. Sınıf öğrencilerinin eleştirel düşünme becerilerini geliştirme düzeyleri üzerinde beceri temelli eleştirel düşünme eğitiminin etkisini araştırmak amaçlanmıştır. Bu program kapsamında fen dersi programında yer alan enerji tasarrufu ve enerjinin verimli kullanımı konusu temel alınmıştır. Araştırmaya katılan ilkokul 3-4. Sınıf öğrencileriyle okuldaki serbest etkinlik saati kapsamında 5 hafta süreyle çalışmalar yürütülmüştür. Araştırmada veri toplamak amacıyla nitel araştırma tekniklerinden yapılandırılmış görüşme tekniği kullanılmıştır. Öğrencilere araştırmacılar tarafından oluşturulan yedi tane açık uçlu soru yöneltilmiştir. Elde edilen verilerin analizinde betimsel analiz kullanılarak araştırmacılar tarafından daha önceden belirlenen temalara göre özetlenmiş ve yorumlanmıştır. Araştırma bulgularından elde edilen sonuçlar öğrencilerin farklı bakış açıları kazandıkları, hayal güçlerini geliştirdiği, düşünmeyi öğrendikleri ve eleştirel düşünme düzeylerinin geliştiğini ifade ettikleri görülmüştür. Bu sonuçlar, ilkokul döneminde erken yaşlardan başlayarak öğrencilere düşünme eğitimleri verilmesinin geliştirilmesinin ne kadar önemli olduğuna dikkat çekmektedir.

Anahtar sözcükler: Beceri temelli eleştirel düşünme, Cort düşünme programı, eleştirel düşünme düzeyi, ilkokul

ABSTRACT: In this study, it was purposed to investigate the effects of skill-based critical thinking education on the levels of developing critical thinking skills of 3rd-4th grade primary school students. Within the framework of this program, energy saving and productive energy using subjects that rank among science course program were used as base. With primary school students that participated in the research, studies were conducted for five weeks within the frame of free activity hours. In the research, interview technique structured with qualitative research techniques was used in order to gather data. Students were addressed seven open-ended questions that were prepared by the researchers. We summarized and interpreted data obtained according to themes that were predetermined by researchers using descriptive analysis. According to findings, it was concluded that students expressed that they have gained different view of points, developed their imaginations, learned thinking, and developed their critical thinking levels.

Key words: Skill-based critical thinking, Cort thinking program, critical thinking level, primary school

GİRİŞ

Eleştirel düşünme, öğrenimin ilk yıllarından itibaren toplumun tüm bireylerine kazandırılması gereken önemli düşünme becerilerindedir. Aslında düşünme, sebep-sonuç ilişkisini kurarak akıl yürütme eylemi iken, eleştirel düşünme, sebep-sonuç ilişkisini kurarken, eski öğrenilenler ile yeni öğrenilenler arasında bir bağ kurma ve bu sırada akılcı olmayan ilişkileri eleme sürecidir (Kahraman, 2008). Eleştirel düşünce; olayları analiz etme,

düşünce üretme ve onu örgütleme, görüşleri savunma, karşılaştırmalar yapma, çıkarımlarda bulunma tartışmaları değerlendirme ve problem çözme yeteneğidir (Chance, 1986; Akt. Şahinel, 2007).

Eleştirel düşünebilmenin yolunun iyi bir eğitimden geçtiği düşüncesiyle nitelikli insan yetiştirmek için eğitimi araç olarak kullanmak en kolay ve en etkili yol olacaktır. Ancak yapılan çalışmalar; bu eğitimin sınırlı alanda ve belirli bir yaştan sonra yapılmasının yeterli ve beklenen düzeyde gerçekleşmediğini göstermektedir (Kökdemir, 2012). 21. yüzyıl eğitimi, esneklik, kendi kendine öğrenme, olaylara geniş bir açıdan bakabilme, eleştirel düşünebilme ve yaratıcı problem çözme yeterliliğine sahip vatandaşlar gerektirmektedir (Kepenekçi, 2000). Bu gereksinim neticesinde Watson ve Glaser (1964)'in belirttiği gibi eleştirel düşünme; problem çözme, sorgulama ve araştırma gibi edimleri kapsayan genel bir süreç olarak tanımlanmaktadır (Akt. Vural ve Kutlu, 2004). Öyleyse var olan, öğrenilebilecek ve öğretilen bir takım eleştirel düşünme yetenekleri öğrenilebilir ve uygun bir şekilde kullanılabilir. Bu yeteneklerin gelişmesi uzun ve zorlu bir düşünme süreci yaşamaktan geçmektedir.

Eleştirel düşünme alanyazını incelendiğinde, araştırmacıların ve yazarların eleştirel düşünme öğretiminin gerekliliği konusunda görüş birliği içinde oldukları görülmektedir. Ancak, eleştirel düşünmenin nasıl öğretileceği, hangi yaklaşımın daha etkili olacağı soruları tam olarak cevaplanamamıştır. Beyer (1991), eleştirel düşünme becerilerinin geliştirilmesinin zaman alacağını belirterek, bu becerilerin uzun süreli düşünme incelemelerinin içinde tutulan öğrencilerin kazanabileceğini ileri sürmekte, beceri temelli olarak öğretilen becerilerini belirtmektedir. (Akt. Aybek, 2007). Enis (1991)'e göre eleştirel düşünme beceri temelli öğretilmelidir. Beceri temelli öğretildiğinde, konu içerisindeki temel disiplinlerin tekrarlanmasından kaçınılmış olur ve aynı zamanda kazanılan bilişsel becerilerin diğer derslere uygulanması ve o dersler tarafından desteklenmesi kolay olur (Aybek, 2007). Beceri temelli eleştirel düşünme eğitiminin en önemli savunucusu olan ve CORT (Cognitive Research Truth) programını hazırlayan Edward De Bono'dur. Oldukça basit bir program olan Cort, çoğu durumlar için uygulanabilir 10 dersten oluşmaktadır. Edward De Bono'ya göre Cort düşünme programı, düşünme becerilerini geliştirmek için hazırlanmış bir programdır. Düşünmeyi bir beceri olarak geliştirmenin avantajı, bu becerinin tek bir alanda geliştirilmediği için her durumda kullanılabilmesidir. Düşünme doğal değildir. Nasıl yapıldığını öğrendikten sonra yüzme gibi bisiklet sürme gibi doğal hale gelebilir (Kurnaz, 2011).

Fen ve Teknoloji dersinin öğretim programı dersin amacını tanımlarken eleştirel düşünmeyi öne çıkarmıştır. Bilimsel süreç becerilerine sahip bireyleri, günlük yaşamlarındaki olayları sorgulayan ve araştıran, eleştirel düşünebilen, karşılaştıkları problemleri bilimsel yollarla çözebilen, karar verme becerileri gelişmiş bireyler olarak tanımlanmaktadır (İleri, 2012).

Gelişen teknoloji, enerjinin kullanımı ve dünyamızdaki kaynakların sınırlılığı, öğretim programına konu olmaktan öteye giderek ünite haline gelmiştir. Geleceğin bireyleri olacak olan öğrenciler, yetişkin bireyler olduklarında elde ettikleri becerileri elbette kullanacaklardır. Beceri temelli düşünme eğitimlerinin daha küçük yaşlarda verilmesi ve kazanılan becerilerin nasıl kullanılması gerektiğinin öğretilmesi gerekmektedir. Bu durumda eleştirel düşünme öğrenmede beceri temelli yaklaşımın, eleştirel düşünme becerileri kazanmadaki etkisinin araştırılması önem kazanmaktadır. Bu amaçla bu çalışmada, beceri temelli eleştirel düşünme eğitiminin ilkökul 3. ve 4. Sınıf öğrencilerinin eleştirel düşünme becerilerini geliştirme düzeylerine etkisinin araştırılması amaçlanmıştır.

YÖNTEM

Araştırma Modeli

Araştırmada model olarak nitel araştırma modeli kullanılmıştır.

Çalışma Grubu

Araştırmanın çalışma grubunu 2013-2014 eğitim-öğretim yılında Konya Mehmet Hasan Sert İlkokulunda okuyan 3. ve 4. sınıfta öğrencileri oluşturmaktadır. Araştırmaya 26 kız, 25 erkek olmak üzere toplam 51 öğrenci katılmıştır.

Veri Toplama Aracı

Araştırmada veri toplamak amacıyla nitel araştırma tekniklerinden yapılandırılmış görüşme tekniği kullanılmıştır. Öğrencilere araştırmacılar tarafından oluşturulan yedi tane açık uçlu soru yöneltilmiştir.

Verilerin Analizi

Elde edilen verilerin analizinde betimsel analiz kullanılarak arařtırmacılar tarafından daha önceden belirlenen temalara göre özetlenmiş ve yorumlanmıştır.

BULGULAR

Öğrencilerin Cort Düşünme programı sırasında uygulanan konu ve beceri temelli düşünme programında verdikleri yanıtlara ilişkin bulgular

Arařtırmaya katılan 3. ve 4. Sınıf öğrencilerinin Cort düşünme programındaki 10 ders programı kapsamında, grup çalışmaları sonucunda ortaya koydukları görüşler Tablo 1’de verilmiştir.

Tablo 1: Cort Düşünme Programı Kapsamında Öğrenci Görüşleri			
Cort Düşünme Programı Dersler	Uygulama Basamakları	3. sınıf	4. sınıf
1	Uygulama 2 Evde elektrikli araçların kullanımı yasaklanmalıdır.	<ul style="list-style-type: none">• Karanlıkta korku hikâyeleri anlatırız.• Ödevlerimizi yapamayız.• Teknolojiden yararlanamayız. Bol bol bahçeye iner oyun oynarız.	<ul style="list-style-type: none">• Daha çok tasarruf yapabiliriz (çocuklar tasarruf yapmayı öğrenir.) Aile bağımız daha çok güçlenir.• İletişim kurmamızı azaltır.• Çocuklar doğa ve tabiat ile daha çok ilgilenir.
2	Uygulama 1 Evinize elektrikli ısıtıcı alacağınız zaman nelere dikkat edersiniz?	<ul style="list-style-type: none">• Kalitesine• Güvenli mi?• Emniyet kilidine• Fazla elektrik tüketmemesine	<ul style="list-style-type: none">• Sağlığımıza zarar verir mi?• Garanti belgesine.• Markasına.• Ne kadar elektrik harcadığına.• Dekoratif olmasına.
3	Uygulama 1 Evimize gelen elektrik faturası çok fazla. Faturayı azaltmak için 4 kural belirleyiniz.	<ul style="list-style-type: none">• Gereksiz ışıkları söndürürüz.• Elektrikli eşyaları tasarruf yaparak kullanmak.• Gizlice televizyonla ve bilgisayarla oynamak yasak!	<ul style="list-style-type: none">• Açık gördüğümüz lambaları kapatmak• Evdeki aydınlanma lambaların tasarruf lambaları ile değiştirmek.• Çocukları tasarruf yapmaya alıştırmak.
	Uygulama 2 1. sorudan devam (fikirlerin ele alınmış yöntemi, pozitif, negatif, ilginç)	<ul style="list-style-type: none">• Evimizdeki aydınlatma lambalarının yerine tasarruf lambalarının takılması (pozitif)• Tasarruf yapılabilmesi (ilginç)	<ul style="list-style-type: none">• Tasarruf yapmış oluruz (pozitif).• Lambaların fiyatı artar (negatif).• Sağlığımızı korumuş oluruz.
	Uygulama 3 Evinizde bir tane televizyon var ve herkes farklı kanallar izlemek istiyor. Sizde bir program yaparak bunu düzene koyacaksınız. Bunu yaparken nelere dikkat	<ul style="list-style-type: none">• Programın ailemin istediği gibi olması• Başkasının fikrine önem göstermemek• Hafta sonu herkesin izleyeceği bir şey açarız.	<ul style="list-style-type: none">• Herkesin süresi aynı olmalıdır.• Çocuklar ödevlerini yaptıktan sonra izlemeli.• Aile bireylerinin uygun oldukları zamanda izlemelerini sağlamak

	edersiniz?		
4	<p>Uygulama 1</p> <p>Enerji tasarrufu yapmak için evlerde kullanılan aydınlanma araçlarının akşam 8'den sonra kullanılması yasaklanmıştır. Bu durumun kısa vade, orta vade, uzun vade sonuçları neler olur? (vade kelimesinin anlamını bilmiyorlardı)</p>	<ul style="list-style-type: none"> Birkaç ay sonra akşam 8 de yatmak zorunda kalırız. (UV) Lambaya ihtiyaç olmayabilir. (OV) Körebe oynarız. (KV) 	<ul style="list-style-type: none"> Elektrik tasarrufu yapabiliriz (UV). Işıklar olmadığında daha çok sıkıldığımız için bilgisayar ve televizyona daha fazla bakarız. Buda olumsuz sonuç doğurur (UV). Erken yatmaya alışırız (OV).
5	<p>Uygulama 3</p> <p>Her insan televizyon seyretmek ister. Annenizin, babanızın, kardeşinizin, televizyon üreticisinin, elektrik dağıtım firmasının televizyon konusundaki amaçları neler olabilir?</p>	<ul style="list-style-type: none"> Yemek programları ve dizi (anne) Maç ve haber izlemek (baba) Çizgi film izlemek (kardeş) Para kazanmak (üretici) Para kazanmak, işlerimizi kolaylaştırmak (dağıtıcı firma) 	<ul style="list-style-type: none"> Yemek programları ve dizi (anne) Maç ve haber izlemek (baba) Çizgi film izlemek (kardeş) Çocuk şeylerini izleyip hayal gücünü geliştirmek için (kardeş) Para kazanmak (üretici) Para kazanmak, (dağıtıcı firma)
6	<p>Uygulama 1</p> <p>Hükümet aldığı bir kararla, bütün arabaların dönüşümlerinin yapılarak elektrikle çalışır/kullanılabilir duruma gelmesini zorunlu hale getirmiştir. Hükümetin amaçları neler olmalıdır?</p>	<ul style="list-style-type: none"> Doğa kirliliğini engelleme Egzozdan çıkan dumanın hava kirliliği yapmaması Elektrikle daha yavaş gidip kaza yapmamak. 	<ul style="list-style-type: none"> Çevreyi temiz tutmak. Arabamızın tasarruflu olmasını sağlamak Tüplü arabalara oranla daha güvenli.
	<p>Uygulama 2</p> <p>Hükümet ne yapmalıdır? Üç aşamalı bir plan yapınız.</p>	<ul style="list-style-type: none"> Arabalarını elektrikli yapanlara para vermek. Sanayiye geliştirmek. Elektrikli olmayan arabaların paralarını çoğaltmak! Afişler asmak, halkı bilgilendirmek. Kazalar azalır mı, azalmaz mı diye kamera koymak. Vergiyi azaltmak. 	<ul style="list-style-type: none"> Benzin istasyonlarının yerine elektrikli istasyonlar yapılmalı. Reklam yaparak halk bilinçlendirilmeli. İlk önce araba yapanlarla anlaşılmalı. Arabayı elektrikli yapmayanlar ceza almalı.
	<p>Uygulama 3</p> <p>Yukarıdaki planlardan birini seçerek bu planı kısa (1-5 yıl) ve orta (5-25 yıl) dönem sonuçlarını yazınız.</p>	<ul style="list-style-type: none"> Kazalar azalır. (UV) Bir yıl sonra elektrikli arabalara zam gelir. (KV) Bizim ülkemizi örnek alarak başka ülkelerde kullanmaya başlar (UV) 	<ul style="list-style-type: none"> Daha az para gider tasarruf yaparız (KD). Ülke daha zengin olur (UD). İnsanlar sağlıklı olur (KD). Çevremiz temiz olur (UD).
7	<p>Uygulama 2</p> <p>Kardeşinizin gece yatarken sürekli TV'yi açık bıraktığını</p>	<ul style="list-style-type: none"> TV bir ay içinde her zaman kapatırsa ödül alabiliriz. Saat kurma düğmesini öğretirim (otomatik kapanma). 	<ul style="list-style-type: none"> Kapatmadığında paramızın boşa gittiğini söylerim. Alarm sistemini kurarım.

	fark ettiniz, ne yaparsınız?	<ul style="list-style-type: none"> • Televizyonu kapatırsa tasarruf olacağını söylerim. 	
8	Uygulama 3 Ülkedeki enerji tüketimi çok fazla arttı. Eğer enerji bakanı olsaydınız bu sorunu çözmek için ne tür alternatifleriniz olurdu?	<ul style="list-style-type: none"> • Az elektrik harcayan ampulleri zorunlu yaparım, az elektrik harcayana ödül vereceğimi söylerim. • Çocuklara enerjinin ne demek olduğunu öğretmek için enerji oyuncuğu çıkarırım. 	<ul style="list-style-type: none"> • Elektriği azaltan makine yaparım. • Kampanya düzenlerim. Halkı bilgilendiririm. • Herkese belirli miktarda elektrik veririm. • Halktan daha çok para alırım.
9	Uygulama 1 Bir arkadaşınızın sınıfın elektrik prizini oynadığını gördünüz ve sınıfta sadece siz varsınız. Acil karar vermek zorundasınız. Ne yaparsınız?	<ul style="list-style-type: none"> • Başka bir şeye yönlendiririm. • Sigortayı kapatırım. • En yakındaki görevliye haber veririm. 	<ul style="list-style-type: none"> • Nöbetçi öğretmene haber veririm. • Onunla oyun oynarım, bu şekilde prizden uzaklaştırırım. • Şalteri indiririm.
10	Uygulama 2 Enerji kullanımını uygun hale getirmek için yeni elektrikli araçlar üretilmiştir. Bu buluşa devletin, üretici firmanın, babanızın ve sizin bakış açınız nasıldır?	<ul style="list-style-type: none"> • Devlet; Ülkenin tasarruflu olmasını sağlamak. Enerji kaynaklarını az kullanmak. • Firma; para kazanmak. • Baba; elektrik faturasının az gelmesi. 	<ul style="list-style-type: none"> • Devlet: Kaynakları düzgün kullanmak. • Baba: daha tasarruflu oluruz. • Üretici firma: para kazanmak. • Ben: enerjeyi daha uygun kullanmayı öğrenmek.

Öğrencilerin Cort Düşünme programı sonrasında kendilerine yöneltilen 7 açık uçlu soruya verdikleri yanıtlara ilişkin bulgular

3. sınıf öğrencilerinin açık uçlu sorulara verdikleri yanıtlar uygun kategoriler altında toplanarak; öğrencilerin bu kategorilerde verdikleri örnek ifadeler Tablo 2’de gösterilmiştir.

Tablo 2: 3. Sınıf Öğrencilerinin Açık Uçlu Sorulara Verdikleri Yanıtlara İlişkin Görüşler		
SORULAR	KATEGORİLER	ÖRNEK İFADELER
Soru 1	Evet; <ul style="list-style-type: none"> • Zevkli/güzel/heyecanlı • Düşünme becerisini geliştirme • Fikirleri ve görüşleri geliştirme, paylaşma • Hayal gücünü geliştirme • Grup dinamiği • Eğitici • Oyun oynayarak öğrenme 	<p>“Çok zevkliydi. Çünkü herkes düşüncelerini, fikirlerini ve görüşlerini söyledi.”</p> <p>“Yaptığımız eğitim hem eğlenceli hem de eğiticiydi, bir de arkadaşlarımla beraber olmak çok güzeldi.” “Hayal gücümü geliştirdim, çok eğlendim.”</p>
	Hayır; <ul style="list-style-type: none"> • Sıkıcı 	<p>“Son zamanlar biraz sıkıcı geçti çünkü cevap bulmada zorlandık.”</p>

Soru2	<ul style="list-style-type: none"> Nasıl düşündüğümüzü belirlemek Hayal gücümüzü geliştirmek Zekamızı geliştirmek Farklı bakış açıları kazanmak Fikirlerimizi geliştirmek Çalışkan ve bilgili olmamızı sağlamak 	“Bu eğitimden sonra günlük hayata farklı açılardan bakıyorum.”
Soru 3	Evet; <ul style="list-style-type: none"> Alış verişte daha dikkatli Bardağından dolu tarafından bakma Daha fazla düşünerek hareket etme Farklı bakış açısı kazanma Saygı Daha dikkatli 	“Evet, çünkü bakış açım değişti.” “Geçen gün bana bir mp3 çalar alacaktık. Ben eğitimden sonra ürünleri daha çok araştırdığım için mp3 çaları araştırdım, meğerse kalitesiz bir ürünmüş.” “Evet, mesela bazı şeyler alırken daha dikkatli oluyorum. Faturaları alıyorum, garanti belgesini alıyorum.” “Evet, mesela para biriktiriyorum, lambaları kapatıyorum.”
	Hayır; <ul style="list-style-type: none"> Henüz karşılaşmadım. 	-
Soru 4	Evet; <ul style="list-style-type: none"> Eskisinden daha farklı eleştirel bakış Öncesi ve sonrasında ne yapacağımı bilme Daha fazla düşünme Farklı açılardan bakabilme Pozitif ve negatif yönlerini görebilme Yanlış ve doğruyu görme Arkadaş seçiminde Hayata bakış 	Gelişti, çok düşünemiyordum. Her şeye farklı açıdan bakabiliyorum. Her şeyin pozitif negatif yönlerini öğrendim. Biraz, çünkü bir şey yaparken artık daha uzun hayal edebiliyorum.
	Hayır; <ul style="list-style-type: none"> Pek değil. 	
Soru 5	Evet; <ul style="list-style-type: none"> Olayların olumlu ve olumsuz yönlerine dikkat etme Farklı bakış açısı kazanma İyi ve kötü yanlarını görebilme Gereklilik 	Evet daha eleştirel bakıyorum. Bakış açım değişti. Evet çünkü her şeyin iyi ve kötü yanlarını öğrendim.”
	Hayır; <ul style="list-style-type: none"> Arkadaşlar kırılabılır. 	
Soru 6	Evet	<ul style="list-style-type: none"> 7, 8, 9. Aşamalarda zorlandık.
Soru 7	Evet; <ul style="list-style-type: none"> Günlük hayatı kolaylaştırma Günlük hayatta kullanma Eğlenceli/zevкли/güzel Daha iyi düşünebilme becerisi Yeni fikirler bulmak Bilgi edinmek Umut 	“Devam etmesini istiyorum. Çünkü, zevкли, eğlenceli ve daha bir sürü şey.” “Evet çünkü orada çok eğleniyordum, düşünmek ve yeni fikirler bulmak güzeldi. Beni çok mutlu ediyordu.” “Umudumu kaybetmemek için.”
	Hayır;	

	<ul style="list-style-type: none"> • Sıkıcı • Zor • Eleştirmeyi sevmiyorum. • Süresi uzun 	
--	---	--

4. sınıf öğrencilerinin açık uçlu sorulara verdikleri yanıtlar uygun kategoriler altında toplanarak; öğrencilerin bu kategorilerde verdikleri örnek ifadeler Tablo 3’te gösterilmiştir.

Tablo 3: 4. Sınıf Öğrencilerinin Açık Uçlu Sorulara Verdikleri Yanıtlara İlişkin Görüşler		
SORULAR	KATEGORİLER	ÖRNEK İFADELER
Soru 1	Evet; <ul style="list-style-type: none"> • Zevkli /Eğlenceli • Düşünme becerisini geliştirme • Fikirleri ve görüşleri paylaşma • Hayal gücünü geliştirme • Zekâmız geliştirdi • Eğitici 	<p>“Çok zevkliydi. Çünkü herkes düşüncelerini, fikirlerini ve görüşlerini söyledi.”</p> <p>“Zevk aldım çünkü herkes yapabildi.”</p> <p>“Eğitici ve daha iyi düşünmemizi sağladı.”</p>
	Hayır; <ul style="list-style-type: none"> • Cevap bulma zorluğu • Sıkıcı • Grup dinamiği 	<p>“Son zamanlar biraz sıkıcı geçti çünkü cevap bulmada zorlandık.”</p> <p>“Hayır, çünkü gurubum kötüydü.”</p>
Soru2	Evet <ul style="list-style-type: none"> • Nasıl düşündüğümüzü belirlemek • Düşünme becerimizi geliştirmek • Hayal gücümüzü geliştirmek • Zekâmızı ölçmek ve geliştirmek • Farklı bakış açıları kazanmak • Kendi düşüncelerimizi paylaşmak • Bilgi seviyesini ölçmek 	
Soru 3	Evet; <ul style="list-style-type: none"> • Alış verişte daha dikkatli • Bardağından dolu tarafından bakma • Daha fazla düşünerek hareket etme • Doğru karar verebilme • Düşünme gelişimi • Tasarrufu öğrettiği için • İyi şeyler düşünme • Hayal gücünü geliştirme • Tutumlu olma 	<p>“Evet, bakabiliyorum, hayal gücümü kullanıp değişik şeyler yapıyorum.”</p>
Soru 4	Evet; <ul style="list-style-type: none"> • Eskisinden daha farklı eleştirel bakış • Öncesi ve sonrasında ne yapacağımı bilme • Eskisinden daha başarılı olma • Düşünme becerisinin gelişimi • Çevresiyle daha iyi anlaşabilme • Her şeyin önemini daha iyi anlama 	<p>“Evet çünkü Sherlock Holmes olduk ve çok işe yarıyor.”</p> <p>“Bence geliştirdi ama buna ben değil çevrem karar verir.”</p>

	<ul style="list-style-type: none"> • Zekâyı güçlendirme 	
Soru 5	Evet; <ul style="list-style-type: none"> • Olayların olumlu ve olumsuz yönlerine dikkat etme • İnsanlar farklı olabilir. • Öğretmenimiz çok emek verdi. • Düşünme gelişimi • Mantıklı düşünmeyi fark etme • Zekâm geliştirdi. • Çevresiyle daha iyi anlaşabilme • Daha tutumluym. • Düşünerek karar verme • Daha çalışkan olma 	“Evet, öyle çünkü daha mantıklı düşündüğümü fark ettim.” “Evet, çünkü bu çalışmadan sonra düşünerek karar veriyorum.”
	Hayır; <ul style="list-style-type: none"> • İnsanları eleştirmeyi sevmeme • Herkesin kendi hayatının olması 	“Hayır, çünkü herkesin kendi hayatı var.”
Soru 6	Evet	<ul style="list-style-type: none"> • 7, 8, 9. aşamalarda
	Biraz	<ul style="list-style-type: none"> • 3. aşamada
	Hayır	-
Soru 7	Evet; <ul style="list-style-type: none"> • Günlük hayatı kolaylaştırma • Eğlenceli • Zevkli • Daha iyi düşünebilme becerisi • Hayal gücü gelişimi 	“Devam etmesini istiyorum. Çünkü zevkli, eğlenceli ve daha bir sürü şey.”
	Hayır; <ul style="list-style-type: none"> • Sıkıcı • Eleştirmeyi pek sevmem 	

SONUÇ VE ÖNERİLER

Araştırma bulgularından elde edilen sonuçlar ışığında öğrencilerin farklı bakış açıları kazandıkları, hayal güçlerinin geliştiği, düşünmeyi öğrendikleri ve eleştirel düşünme düzeylerinin geliştiğini ifade ettikleri görülmüştür. Bu sonuçlar, ilköğretim döneminde erken yaşlardan başlayarak öğrencilere düşünme eğitimleri verilmesinin geliştirilmesinin ne kadar önemli olduğuna dikkat çekmektedir. Korkmaz ve Yeşil'e göre (2009), İlköğretim ile ortaöğretim kademeleri son sınıf öğrencilerinin eleştirel düşünme eğilim ve düzeyleri arasında, ilköğretim kademesindeki öğrencilerin lehine anlamlı bir farklılaşma vardır. Eleştirel düşünme eğilim ve düzeylerinin alt boyutları incelendiğinde ise; açık fikirlilik, kendine güven ve sistematiklik alt boyutlarında ilköğretim kademesindeki öğrenciler lehine anlamlı bir farklılaşma varken diğer alt boyutlarda anlamlı farklılaşma bulunmamaktadır. İlgili araştırma bu çalışmanın bulgularını da desteklemektedir. Eleştirel düşünme, disiplinler arası bir yaklaşım ve *beceri* öğretimi yaklaşımı içerisinde öğretildiği zaman, hem farklı disiplinler içerisinde konuların tekrarlanmasına gerek kalmayacak hem de bilişsel bir beceri olarak tüm disiplinlerin öğretiminde etkin olarak kullanılarak geliştirilebilecektir. Buradan hareketle; eleştirel düşünme becerilerini öğrencilere kazandırmak için okullarda eleştirel düşünme becerilerinin kazandırılıp geliştirilebilmesi için hem teorik düzeyde hem de uygulamalı olarak eleştirel düşünme öğretiminin yapılması gerektiği söylenebilir (Korkmaz ve Yeşil, 2009). Aybek (2007) tarafından yapılan çalışma sonunda, eleştirel düşünmenin beceri temelli olarak öğretilmesinin öğrencilerin eleştirel düşünme eğilimini ve düzeyini daha çok artırdığı söylenilebilir. MEB tarafından okullarda uygulanan seçmeli etkinlik kapsamında bulunan kulüp çalışmalarına “Düşünme Kulübü” başlığı altında bir kulüp kurulması; eleştirel düşünme becerilerini geliştirmeye yönelik etkinliklerin yapılacağı daha geniş bir çalışma alanının yaratılmasına destek verecektir (Kahraman, 2008). Okullarımızda, her

sınıf seviyesinde yapılan kulüp çalışmaları ile daha küçük yaşlarda öğrencilerin eleştirel düşünme ile tanışmaları sağlanmış olacaktır. Okullarımızda, her sınıf seviyesinde yapılan kulüp çalışmaları ile daha küçük yaşlarda öğrencilerin eleştirel düşünme ile tanışmaları sağlanmış olacaktır. Bu çalışma sonunda; beceri temelli eleştirel düşünme eğitimlerinin ilkökul seviyesinde farklı konu içeriklerinde de Cortl programı ile uygulanması önerilmektedir. Öğrencilere sunulacak sınıf ortamı, grup ve işbirlikli çalışma durumuna uygun olarak düzenlenmelidir.

KAYNAKLAR

- Aybek, B., (2007). Konu ve Beceri Temelli Eleştirel Düşünme Öğretiminin Öğretmen Adaylarının Eleştirel Düşünme Eğilimi ve Düzeyine Etkisi. *Ç.Ü. Sosyal Bilimler Enstitüsü Dergisi, Cilt 16, Sayı 2, s.43-60*
- Beyer, B. (1991). Teaching Thinking Skills: A Handbook for Elementary School Teachers, Boston, USA, Allyn and Bacon.
- Chance, P. (1986). Thinking in the Classroom: A survey of Programs. New York, USA, Teachers College, Colombia University.
- İleri, Ş., (2012). İlköğretim 4. ve 5. Sınıf Fen ve Teknoloji Dersi Öğretim Programının Öğrencilerin Bilimsel Süreç ve Eleştirel Düşünme Becerilerine Etkisi. Yüksek Lisans Tezi, Uşak Üniversitesi Sosyal Bilimler Enstitüsü Uşak.
- Kahraman, T., (2008). İlköğretim 4. ve 5. Sınıf Öğrencilerinin Eleştirel Düşünme Becerileri İle Öğrenci Algılarına Göre Öğretmenlerin Sınıf İçi Demokratik Davranış Düzeyleri Arasındaki İlişkinin İncelenmesi. Doktora Tezi, Marmara Üniversitesi, Eğitim Bilimleri Enstitüsü, İstanbul.
- Kenepekçi, K. Y., (1999). Türkiye’de Genel Ortaöğretim Kurumlarında İnsan Hakları Eğitimi. Doktora Tezi, Ankara Üniversitesi, Sosyal Bilimler Enstitüsü, Ankara.
- Korkmaz, Ö. Ve Yeşil R., (2009). Öğretim Kademelerine Göre Öğrencileri Eleştirel Düşünme Düzeyleri. *Ahi Evran Üniversitesi, Eğitim Fakültesi Dergisi, Cilt 10, Sayı 2, Sayfa 19-28*
- Kökdemir D., (2012). Üniversite Eğitimi ve Eleştirel Düşünme. Pivolka.
- Kurnaz, A., (2011). Eleştirel Düşünme Öğretimi Etkinlikleri. Planlama-Uygulama ve Değerlendirme. Konya: Eğitim Akademi.
- Sahinel, S., (2007). Eleştirel Düşünme. Ankara: PegemA Yayıncılık.
- Vural, R., A. ve Kutlu, O. (2004). Eleştirel Düşünme: Ölçme Araçlarının İncelenmesi ve Bir Güvenilirlik Çalışması. *Çukurova Üniversitesi, Sosyal Bilimsel Enstitü Dergisi, Cilt: 13, Sayı: 2, s. 188-200*
- Watson, G & Glaser, M. E. (1964). Watson-Glaser Critical Thinking Appraisal Manual, New York: Harcourt, Brace & World Inc.

ÜNİVERSİTE ÖĞRENCİLERİNİN MEDYA OKURYAZARLIK DÜZEYLERİ

UNIVERSITY STUDENTS' MEDIA LITERACY LEVELS

Çağdaş ERBAŞ
Yüksek Lisans Öğrencisi, Süleyman Demirel Üniversitesi
cagerbas@gmail.com

Veysel DEMİRER
Yrd. Doç. Dr., Süleyman Demirel Üniversitesi
veyseldemirer@gmail.com

ÖZET: 20. yüzyılın başından beri tartışılan bir konu olan ve birçok kitle iletişim aracının kullanımının insan üzerindeki etkilerini ele alan medya okuryazarlığı ülkemiz açısından yeni bir kavram olmakla birlikte özellikle 2005 yılında Marmara Üniversitesinde düzenlenen Medya Okuryazarlığı konferansı sonrasında kitlelerin dikkatini çekmeye başlamıştır. Aynı dönemde RTÜK tarafından başlatılan ve 2006 yılında Milli Eğitim Bakanlığı ile imzalanan bir protokolle ilköğretim ikinci kademe öğrencilerine medya okuryazarlığı dersi seçmeli olarak okutulmaya başlanmıştır. Bireylere medya okuryazarlığının kazandırılması ile kesin doğruyu verip vermediği tartışmalı olan kitlesel medya araçlarına karşı eleştirel bir bakış açısıyla yaklaşımları ve doğru bilgiyi edinmeleri amaçlanmaktadır. Günümüzde toplumlar üzerinde medyanın önemi ve etkisi düşünüldüğünde üniversite öğrencilerinin medya okuryazarlık düzeyleri önem arz etmektedir. Bu araştırma ile üniversite öğrencilerinin medya okuryazarlıkları düzeylerinin bazı değişkenler açısından incelenmesi amaçlanmıştır. Araştırmaya 585 (290 Kız, 295 Erkek) üniversite öğrencisi katılmıştır. Sonuçlar üniversite öğrencilerinin medya okuryazarlık düzeylerinin yüksek olduğunu göstermektedir. Üniversite öğrencilerinin medya okuryazarlık düzeylerinin incelendiği bu çalışmada erkek öğrencilerin kız öğrencilere, üst sınıflarda bulunan öğrencilerin alt sınıflarda bulunan öğrencilere, yaş olarak daha üst gruplarda bulunan öğrencilerin daha alt gruplarda bulunan öğrencilere, internet bağlantısına sahip olan öğrencilerin sahip olmayan öğrencilere, internette daha fazla zaman geçiren öğrencilerin daha az zaman geçiren öğrencilere, düzenli kitap ve gazeteleri okuyan öğrencilerin okumayan öğrencilere, not ortalaması yüksek olan öğrencilerin düşük olan öğrencilere, ailelerinin aylık geliri yüksek olan öğrencilerin düşük olan öğrencilere göre medya okuryazarlık düzeylerinin daha yüksek olduğu ortaya çıkmıştır. Ancak sosyal medya sitelerine üye olmanın, televizyon izleme oranının ve ebeveynlerin eğitim durumunun öğrencilerin medya okuryazarlıkları üzerine bir etkisi bulunmamıştır.

Anahtar Kelimeler: Üniversite öğrencileri, Medya, Medya okuryazarlığı.

ABSTRACT: Media literacy which is a controversial issue since the beginning of the 20th century and argues out the impacts of different kinds of mass media on mankind, is a new concept for our country. It began to draw attention of the society especially after the Media Literacy Conference that has been held in Marmara University in 2005. At that time media literacy lessons were put into primary schools' curricula as an elective course via a protocol cosigned between Radio Television Supreme Council (RTUK) initiated the process and Ministry of Education in 2006 with the aim of giving media literacy to individuals while making them capable of reaching the true information by using a critical approach to controversial mass media organs. Today, the media literacy levels of university students are so crucial considering the importance and influence of the media on society. It was aimed to examine university students' media literacy levels in terms of some variables in this study. 585(290 girls and 295 boys) university students participated in the study. The results have shown that university students have high levels of media literacy. It has also been found that media literacy was higher in male students compared to female students, in senior classes compared to junior classes, in elders compared to youngsters, in those who had internet access compared to those who didn't, in those who used the internet more frequently compared to those who used less frequently, in those who read books and newspapers regularly compared to those who didn't, in those with higher GPA compared those with lower GPA and in those who had higher income level compared to those who had lower income level. However, this paper has shown that social media membership, frequency of watching TV and parents' education levels didn't have effect on media literacy.

Keywords: University students, Media, Media literacy.

ÖĞRETMENLERİN RUTİN OLMAYAN MATEMATİKSEL PROBLEMLERİ ÇÖZMEDE KULLANDIKLARI STRATEJİLER

SOLUTION STRATEGIES USED BY BOTH MATHEMATICS AND CLASSROOM TEACHERS ABOUT NON ROUTINE PROBLEM TYPES

Ayten Pınar BAL
Çukurova Üniversitesi
apinar@cu.edu.tr

ÖZET: Bu çalışmanın temel amacı matematik ve sınıf öğretmenlerinin rutin olmayan problemlerin çözümünde kullandıkları stratejileri belirlemektir. Araştırmanın çalışma evrenini 2013-2014 yılında Adana ili merkez ilçelerinde Milli Eğitim Bakanlığı'na bağlı farklı ilkököl ve ortaokullarda görev yapan 27 öğretmen oluşturmuştur. Araştırmada bireylerin çeşitliliğini maksimum derecede yansıtmak amacıyla, amaçlı örneklem yöntemlerinden maksimum çeşitlilik örnekleme kullanılmıştır. Çalışmada veri toplama aracı olarak araştırmacı tarafından geliştirilen "Strateji Belirleme Testi (SBT)" kullanılmıştır. Strateji Belirleme Testi (SBT) on problemi ve açık uçlu iki soruyu kapsamaktadır. Araştırmanın sonunda hem matematik hem de sınıf öğretmenlerinin sıklıkla şekil çizme, muhakeme yapma ve problemi basitleştirme stratejilerini kullanırken rutin olmayan tarzdaki problemlerin sınıf içinde uygulanması konusunda öğretmenlerin hepsinin olumlu görüşler bildirdikleri bulgusuna ulaşılmıştır. Bu bulgulardan yola çıkarak bu tür stratejilerin geliştirilmesine yönelik özellikle lisans düzeyinde eğitim verilmesi; ilköğretimden başlayarak matematik programlarında rutin olmayan problemlere daha fazla yer verilmesi önerilebilir.

Anahtar sözcükler: matematik öğretmeni, sınıf öğretmeni, rutin olmayan problem, problem çözme stratejileri

ABSTRACT: The main purpose of this study is to find out solution strategies used by both mathematics and classroom teachers about non routine problem types. The population of this study is 27 teachers working at different public primary and elementary schools in central districts of Adana province during 2013-2014 academic years. While defining population, maximum variation sampling technique was used in order to reflect individuals' variations in maximum degree. As data collection tool, "Test of Identifying Strategy (TIS)" was developed and used by researcher during the study. TIS enhances ten problems and two open-ended questions. At the end of the study it was found out that, both mathematics and classroom teachers often use strategies related to drawing figures, reasoning and simplification of the problem while all the teachers are of the opinion about using non routine type problems in classroom. Based on these findings, holding courses related to developing solution strategies about non routine problem types in undergraduate level and starting from primary education giving more place to non routine problem types in mathematics curriculums can be suggested.

Key words: mathematics teachers, classroom teachers, non routine problem, problem solving strategies

GİRİŞ

Genel bir ifade ile problem, karşılaşılan sorunlara bireyin hemen bir çözüm getiremediği, ve çıkmaza düştüğü durumlardır (Blum & Niss, 1991; Polya, 1990; Altun, 2009; Van De Walle, 2007). Matematik'in temelini oluşturan problem çözme ise farklı çözüm yollarının sınanmasıyla karmaşık durum ya da olguları sonuçlandırma sürecidir. Problem çözme, matematik öğrenmenin temel bir parçası olup öğrencilerin matematiksel bilgilerinin ve düşüncelerinin gelişmesinde de önemli bir araçtır (NCTM, 2000). Ho'ya (2009) göre de okul matematiğinde kazandırılması gereken temel becerilerden biri olan problem çözme öğrencilerin düşünme süreçlerini ve zihinsel yeteneklerini geliştirmede önemli bir etmendir. Problem çözme sürecinde birey, bir problemle karşılaştığında çözüm için uygun stratejiyi seçer ve sonuçları yorumlar (Altun, 2008). Problem kavramı pek çok matematik eğitimcisi tarafından rutin ve rutin olmayan problemler olarak tanımlanmaktadır (Anderson, 2009; Laterell, 2013; Lee & Kim, 2005; Reusser & Stebler, 1997; Verschaffel, De Corte ve Borghart, 1997; Verschaffel, De Corte ve Lasure, 1994). Gerçek yaşam problemlerini kapsayan rutin olmayan problemler ilköğretim okullarında matematik öğretim programlarının en önemli unsurlarından biridir (Anderson, 2009; NCTM, 2000; Xin, Lin, Zhang, Yan, 2007). Rutin olmayan problemler öğrencilerde gerçek yaşamda karşılaştıkları problem durumları ile ilgili farklı çözüm stratejileri oluşturma ve yorum yapma becerilerinin gelişmesi açısından da büyük önem

taşımaktadır. Öte yandan, öğrencilerin temel aritmetik ve dört işlem becerilerini sınavan rutin problemler ise genelde belli bir formüle dayalı ve yorumdan uzak ezber yoluyla çözülen problemler olarak tanımlanmaktadır (Altun, 2009; NCTM, 2000; Polya, 1990; Van de Walle, 2007).

Literatürde rutin olmayan matematiksel problemlerin çözüm süreçlerini irdeleyen çalışmaların büyük ölçüde öğrenciler üzerine odaklandığı görülmektedir (Altun ve Aslan, 2006; Artut ve Tarım, 2006; Bayazit, 2013; Çelebioğlu ve Yazgan, 2009; Reusser, Stebler, 1997; Verschaffel, De Corte, Lasure, Van Vaerenbergh, Bogaerts, & Ratinckx, 1999; Xin, Lin, Zhang ve Yan, 2007; Yazgan, 2007; Yazgan ve Bintaş, 2005; Yoshida, Verschaffel ve De Corte, 1997). Ancak bu kapsamda öğretmen ve öğretmen adaylarına yönelik olarak yapılan çalışmaların ise sınırlı sayıda olduğu göze çarpmaktadır (Asman & Markovits, 2009; Inoue 2005; Kılıç, 2011; Lee ve Kim, 2005; Verschaffel ve diğerleri, 1997). Bu çalışmalardan elde edilen bulgular ise genelde rutin olmayan problemlerin çözümüne yönelik sorunlara işaret etmektedir. Bu bağlamda, Lee ve Kim (2005) sınıf öğretmeni adayları ile yaptıkları çalışmada sınıf içerisinde kullanılan problem türlerinden hangilerinin “iyi problem” olduğunu belirlemeye çalışmışlardır. Araştırmanın sonucunda öğretmen adaylarının çoğunluğunun tek bir çözümünün olması, kolay ve basit olması ve çok fazla düşünme sürecini içermemesi nedeniyle rutin problemlerin iyi problemler olduğu görüşünde oldukları sonucuna ulaşılmıştır. Öte yandan, Verschaffel ve diğerleri (1997) ise araştırmalarında üç farklı bölümde lisans eğitimlerini sürdüren 332 öğretmen adayının rutin olmayan gerçek yaşam problemlerini nasıl çözdüklerini ve problem çözmeye gerçek yaşam bilgisini sürece ne kadar yansıtıklarını incelemiştir. Araştırmanın sonucunda öğretmen adaylarının rutin olmayan problemlerin çözümünde gerçek yaşamı çözüm süreçlerine dahil etmeden soruları doğrudan cevaplandırma eğiliminde oldukları bulgusuna ulaşılmıştır. Yine, Asman & Markovits (2009) araştırmasında öğretmenlerin ve öğretmen adaylarının sözel problemlerin çözümünde gerçek yaşam bilgisine ne kadar başvurduklarını ve problem çözmeye dair inançlarını incelemiştir. Görüşme yoluyla elde edilen verilerde öğretmen ve öğretmen adaylarının rutin olmayan gerçek yaşam problemlerinin çözümünde çok zorlandıkları ve mesleki deneyimlerinin problem çözümünde önemli bir etmen olduğu bulgusuna ulaşılmıştır. Öte yandan, Kılıç da (2011) araştırmasında ilköğretim matematik öğretmeni adaylarının rutin olmayan problemlere ne türden yanıtlar verdiklerini ve problemlerin çözümüne yönelik olarak yapmış oldukları yorumları irdelemiştir. Araştırmanın sonucunda öğretmen adaylarının genellikle rutin olmayan problemlere gerçekçi olmayan yanıtlar verdikleri gözlemlenmiştir.

Yukarıda sınırlı sayıda ki çalışmalardan da görüldüğü gibi öğretmenlerin ve öğretmen adaylarının rutin olmayan problemlerin çözüm süreçlerine ilişkin sorunlar yaşadıkları; bu kapsamda rutin problemleri ve gerçekçi olmayan mekanik yaklaşımları daha çok tercih ettikleri açıkça görülmektedir. Bu olgudan yola çıkarak bu çalışmanın amacı öğretmenlerin rutin olmayan problemlerin çözümünde kullandıkları stratejileri irdelemektir. Bu genel amaç doğrultusunda aşağıdaki sorulara yanıt aranmıştır.

- 1) Matematik ve sınıf öğretmenlerinin rutin olmayan matematik problemlerini çözmeye kullandıkları stratejiler nelerdir?
- 2) Matematik ve sınıf öğretmenlerinin rutin olmayan matematik problemlerinin uygulanabilirliği konusundaki görüşleri nelerdir?

YÖNTEM

Bu çalışma, öğretmenlerin rutin olmayan problemlerin çözümünde kullandıkları stratejileri belirlemek ve bunların uygulanma sürecine ilişkin görüşlerini ortaya koymak amacıyla yapılan nitel bir çalışmadır.

Çalışma Grubu

Araştırmanın çalışma grubunu 2013-2014 yılında Adana ili merkez ilçelerinde Milli Eğitim Bakanlığı'na bağlı ilköğretim ve ortaokullarda görev yapan 27 öğretmen oluşturmuştur. Araştırmada probleme taraf olabilecek bireylerin çeşitliliğini maksimum derecede yansıtmak amacıyla, amaçlı örneklem yöntemlerinden maksimum çeşitlilik örnekleme kullanılmıştır. Bu bağlamda cinsiyet, branş, mesleki kıdem değişkenleri göz önünde bulundurularak öğretmenlerle görüşmeler yapılmıştır. Görüşmeye katılan öğretmenlerin 15'i bayan ve 12'si erkektir. Branş olarak öğretmenlerin on altısı matematik, on biri ise sınıf öğretmenidir. Mezun olunan okul türü açısından öğretmenlerin yimi beşi eğitim fakültesi mezunu iken ikisi ise yüksek lisans mezunudur. Mesleki kıdem açısından ise, 0-5 yıl kıdeme sahip beş, 6-10 yıl kıdeme sahip dokuz, 11-15 yıl kıdeme sahip sekiz, 16-20 yıl kıdeme sahip beş öğretmenle görüşme yapılmıştır.

Veri Toplama Aracı

Veri toplama sürecinde öğretmenlerin rutin olmayan problemlerin çözümünde kullandıkları stratejileri belirlemeye yönelik olarak araştırmacı tarafından geliştirilen “Strateji Belirleme Testi (SBT)” kullanılmıştır.

Strateji Belirleme Testi (SBT) on problemi ve açık uçlu iki soruyu kapsamaktadır. SBT’inde yer alan problemler ilgili literatürden (Inoue, 2005; Verschaffel ve diğerleri, 1994; Xin ve diğerleri, 2007) yararlanılarak hazırlanmıştır. Bunun yanında testte öğretmenlerin rutin olmayan problemlerin uygulanması konusundaki görüş ve önerilerini belirlemeye yönelik açık uçlu iki soru da yer almaktadır. SBT’nin geçerliğini sınamak üzere, matematik eğitimi alanında iki uzman tarafından testin ölçmeyi hedeflediği davranışlar yönüyle, kapsam ve görünüş geçerliğine sahip olduğu belirlenmiştir. SBT’nin anlaşılabilirliğini ve uygulanabilirliğini test etmek amacıyla gönüllülük ilkesine bağlı kalarak üç matematik öğretmeni ile pilot uygulama yapılmış ve bu süreçte herhangi bir sorunla karşılaşmamıştır.

Verilerin Analizi

Veriler, nitel araştırma tekniklerinden betimsel analiz ve içerik analizi ile yorumlanmıştır. Bu bağlamda, öncelikle rutin olmayan problemlerin analizi yapılırken, elde edilen veriler daha önce ilgili literatürde belirtilen (Altun, 2008; Verschaffel ve diğerleri, 1999; Tertemiz, Çelik ve Doğan, 2014) stratejilere göre kodlanmıştır. Ayrıca öğretmenlerin açık uçlu sorulara verdikleri yanıtlarda ise içerik analizi yöntemi uygulanmıştır. Bu süreçte toplanan veriler önce kavramsallaştırılmış, daha sonra belirlenen kavramlara göre alt başlıklar şeklinde belirlenmiş ve uygun tema ve kodlar oluşturulmuştur (Yıldırım ve Şimşek, 1999).

Araştırmanın güvenilirliğini artırmak için SBT’den elde edilen veriler matematik eğitimi alanında bir uzman tarafından da analiz edilmiş ve iki kodlayıcı arasındaki uyuma oranı .92 olarak hesaplanmıştır. Daha sonra kodlayıcı ve araştırmacı arasında görülen farklı ifadelerde fikir birliğine varılmıştır.

BULGULAR

Bu bölümde araştırmanın alt amacı doğrultusunda matematik ve sınıf öğretmenlerinin rutin olmayan problemlerin çözümünde kullandıkları stratejiler yer almaktadır. Bu konuda öğretmenlerin problemlerin çözüm aşamasında uyguladıkları stratejiler Tablo 1’de gösterilmiştir.

Tablo 1. Matematik ve Sınıf Öğretmenlerinin Branşlarına Göre Rutin Olmayan Problemlerin Çözüm Aşamasında Uyguladıkları Stratejilerin Frekans Dağılımı

	Şekil (Şema, Diyagram) Çizme		Muhakeme Yapma		Tahmin-Kontrol		Problemi Basitleştirme		Bağıntı Kurma		Deneme Yanılma		Sistemik Liste Yapma	
	MÖ	SÖ	MÖ	SÖ	MÖ	SÖ	MÖ	SÖ	MÖ	SÖ	MÖ	SÖ	MÖ	SÖ
	f	f	f	f	F	f	f	f	f	f	f	f	f	f
P1	14	8	6	8	1	-	7	6	2	-	-	-	-	-
P2	4	6	16	10	2	-	9	9	-	-	1	-	-	-
P3	11	9	12	9	2	-	-	-	2	-	-	-	-	-
P4	5	4	14	9	2	-	2	1	-	-	-	-	-	-
P5	5	4	16	11	2	-	9	5	-	-	-	-	-	-
P6	16	11	5	2	1	-	-	-	1	-	2	-	-	-
P7	11	11	14	4	1	-	4	8	2	-	-	-	-	-
P8	7	10	13	9	2	-	6	3	-	-	-	-	-	-
P9	16	11	8	3	2	1	1	2	1	1	8	-	-	-
P10	-	-	4	5	-	-	-	4	2	-	-	-	12	10

MÖ: Matematik Öğretmeni; SÖ: Sınıf Öğretmeni

Tablo 1 incelendiğinde hem matematik hem de sınıf öğretmenlerinin şekil çizme, muhakeme yapma ve problemi basitleştirme stratejilerini sıklıkla kullandıkları görülmektedir. Örneğin, Ö₁₉ kodlu öğretmenin 6. sorunun çözümünde kullandığı şekil çizme stratejisi Şekil 1’de yer almaktadır.

6. Ali ve Mustafa aynı okula gitmektedirler. Ali'nin evi okula 17 km, Mustafa'nın evi ise 8 km uzaklıktadır. Ali'nin evi, Mustafa'nın evine ne kadar uzaklıktadır?

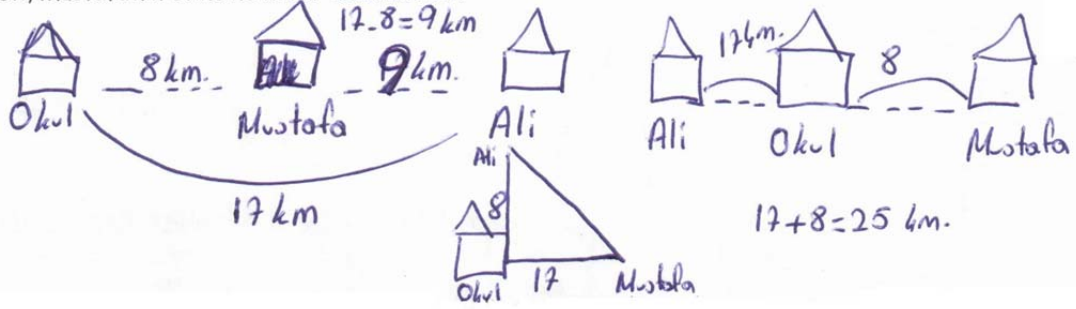

Şekil 1. Ö19 Kodlu Öğretmenin 6. Soruda Kullandığı Şekil Çizme Stratejisi

Şekil 1'de okulun konumu net olarak verilmediğinden dolayı Ö19 kodlu öğretmenin her iki durumu da göz önüne alarak bir şekil çizme stratejisi uyguladığı görülmektedir. Diğer taraftan muhakeme yapma stratejisini uygulayan Ö31 kodlu öğretmen adayının yaptığı çözüm Şekil 2'de yer almaktadır.

10. Şekildeki atış tahtasına üç atış yapan bir kimse kaç değişik toplam puandan birini almış olur?

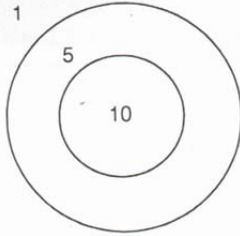

Bu soruyu permutasyon yöntemiyle çözebiliriz. Ama farklı permutasyon gruplarındaki sayıların toplamı aynı olabilirizinden,

a) 3 atışta da farklı bölgeleri varsa sırası önemli değildir. toplam 16 puan alır. $(1+5+10=16)$

b) 3 atışta, 2'si aynı 1'i farklı olursa $(1+5, 1+10, 5-5-10, 10-10-5, 10-10-1, 5-5-1)$ olup bunların toplamları 7, 12, 20, 25, 21 ve 11 olup.

c) 3 atışta da aynı bölgeyi varsa $(1-1-1, 5-5-5, 10-10-10)$, 3, 15 ve 30 puan alır ve

toplamda 10 farklı puan olur.

Şekil 2. Ö31 Kodlu Öğretmenin 10. Soruda Kullandığı Muhakeme Yapma Stratejisi

Şekil 2 incelendiğinde, Ö31 kodlu öğretmenin üç atışın farklı bölgelere isabet etme durumunu, iki atışın aynı bölgeye isabet etme durumunu ve tüm atışların aynı bölgeye isabet etme durumunu göz önünde bulundurarak bir muhakeme yaptığı görülmektedir. Ayrıca sistematik liste yapma stratejisinin de aynı problemde uygulandığı Şekil 3'te görülmektedir.

10. Şekildeki atış tahtasına üç atış yapan bir kimse kaç değişik toplam puandan birini almış olur?

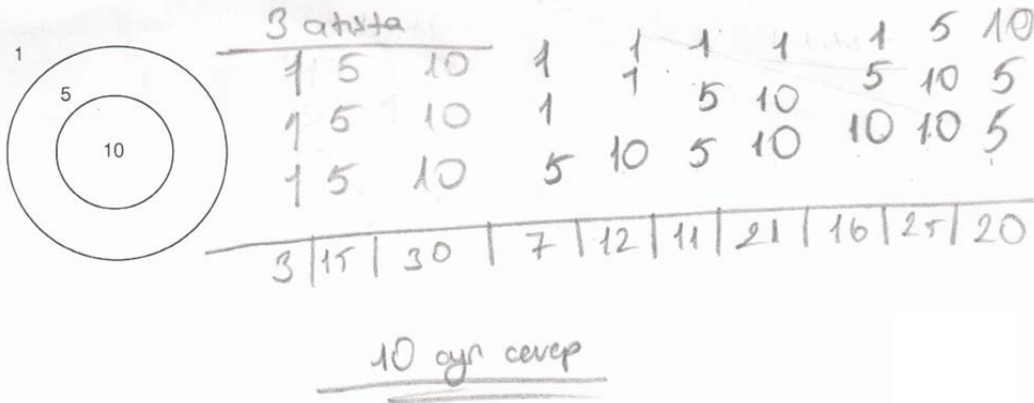

Şekil 3. Ö20 Kodlu Öğretmenin 10. Soruda Uyguladığı Sistematik Liste Yapma Stratejisi

Şekil 3 incelendiğinde, Ö₂₀ kodlu öğretmenin 10. sorunun çözümünde sistematik olarak önce her üç atışın aynı bölgeye, sonra iki atışın aynı bölgeye ve son olarak da üç atışında farklı bölgelere isabet etmesi durumunu göz önüne alarak bu sorunun çözümüne ulaşılmıştır.

Ancak Tablo 1 incelendiğinde tüm öğretmenlerin tahmin kontrol, bağıntı kurma ve deneme yanılma stratejilerini çok az kullandığı görülmektedir. Örneğin, Ö₅ kodlu öğretmenin 9. sorunun çözümünde kullandığı deneme yanılma stratejisi Şekil 4’de yer almaktadır.

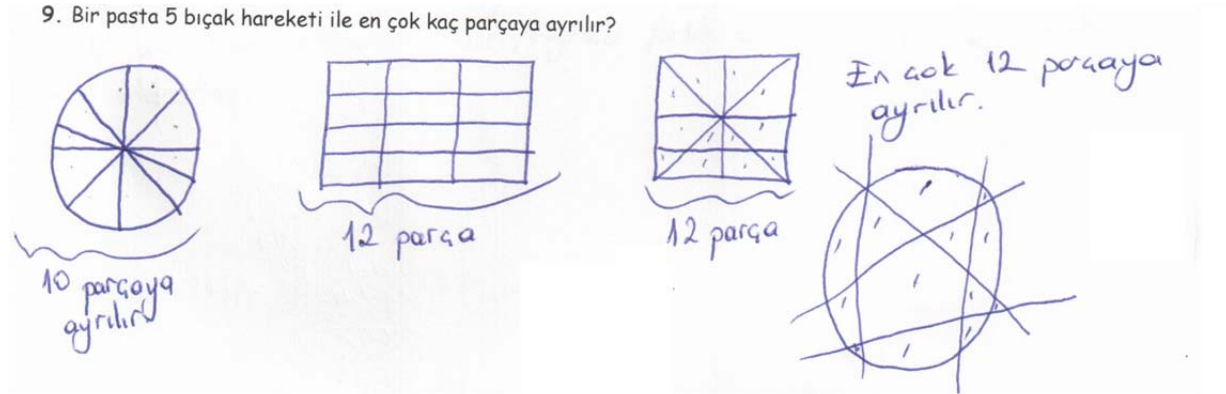

Şekil 4. Ö₅ Kodlu Öğretmenin 9. Soruda Kullandığı Deneme Yanılma Stratejisi

Şekil 4 incelendiğinde, Ö₅ kodlu öğretmenin 9. sorunun çözümünde uyguladığı deneme yanılma stratejisinde pastanın yuvarlak, kare, dikdörtgen olma durumu ve farklı bıçak hareketlerini değerlendirerek çözüme ulaştığı görülmektedir. Bununla birlikte bağıntı kurma stratejisine ilişkin Ö₁₄ kodlu öğretmenin uyguladığı çözüm Şekil 5’te yer almaktadır.

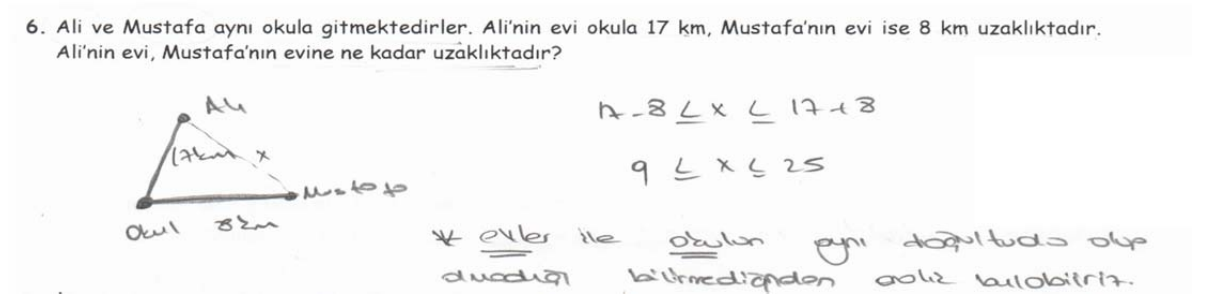

Şekil 5. Ö₁₄ Kodlu Öğretmenin 6. Soruda Uyguladığı Bağıntı Kurma Stratejisi

Şekil 5’de okulun konumu net olarak verilmediğinden dolayı Ö₁₄ kodlu öğretmenin sorunun çözüm aşamasında üçgen eşitsizliği bağıntısından yararlandığı görülmektedir..

Araştırmanın ikinci alt amacında matematik ve sınıf öğretmenlerinin rutin olmayan problemlerin sınıf içi uygulanabilme süreçlerine ilişkin görüşleri yer almaktadır. Araştırmaya katılan öğretmenlerin tamamı bu tür problemlerin sınıf içinde uygulanması gerektiğini belirtmiştir. Bu tür problemlerin uygulanabilirliği konusundaki görüşler Tablo 2’te gösterilmiştir.

Tablo 2. Rutin Olmayan Problemlerin Uygulanabilirliğine İlişkin Öğretmenlerin Görüşleri

Temalar	Kodlar	f
Öğrencilere Kazandırdıkları	Matematiği günlük yaşamla ilişkilendirebilme	11
	Üst düzey düşünebilme becerisi kazandırma	10
	Farklı bakış açısı kazandırma	8
	Düşünmeye yöneltme	8
	Matematiğe yönelik olumlu tutum geliştirme	4
	Konuyu daha iyi kavrama	2
Öneriler	Sınıf seviyesine göre düzenlenme yapabilme	3
	Bireysel özellikleri göz önünde bulundurma	

Tablo 2’de görüldüğü gibi, öğretmenlerinin yaklaşık üçte biri matematiğin günlük yaşamla ilişkilendirilebildiğini (11) ve öğrencilerin üst düzey düşünebilme becerilerini geliştirdiğini (10) belirtmiştir. Bu bağlamda, Ö23 kodlu öğretmen “*öğrencilere bu tür problemler öğretilmelidir. Öğrenci farklı düşünmesinin yanında karşısına gelecek diğer sorularda da yorum gücü artar....düşünme, problem çözme ve sorgulama becerisini geliştirir. Ayrıca sadece okuldaki ders için değil hence güncel hayatta da karşısına gelebilecek tarzda sorular olup zekasını da çalıştırır...*” şeklinde görüş belirterek öğrencilerin üst düzey düşünme becerilerine vurgu yapmıştır. Ayrıca öğretmenlerin dörtte biri rutin olmayan problemlerin farklı bakış açısı kazandırdığını ve öğrencileri düşünmeye yönelttiğini de belirtmişlerdir. Örneğin Ö16 kodlu öğretmen “*...elbette bu tür problemler öğrencileri düşünmeye, çabalamaya yönlendiriyor. ..üst düzey düşünme becerilerini geliştiriyor. Çözdükleri çeşitli yöntemler gereği, çizdikleri şekiller gereği bilgi düzeylerini, hazırbulunuşluk düzeylerini gözden geçiriyor. Sadece öğrenciler değil biz öğretmenler de ne öğrettiğimizi, nasıl öğrettiğimizi, harcadığımız emeğin ne derece işe yaradığını görmüş oluyoruz...*” biçiminde görüşünü belirtmiştir. Diğer taraftan öğretmenlerden çok azı ise matematiğe yönelik olumlu tutum geliştirdiğini (4) ve konuyu daha iyi kavradıklarını (2) belirtmişlerdir. Bu yönde Ö6 kodlu öğretmen “*..bu tür günlük yaşamla ilişkilendiren problemler sayesinde çocuğun konuyu daha iyi algılaması sağlanır*” şeklinde görüş belirterek konunun daha iyi anlaşıldığını ifade etmektedir.

SONUÇ ve ÖNERİLER

Matematik ve sınıf öğretmenlerinin rutin olmayan problemlerin çözümünde kullandıkları stratejileri belirlemek ve bu problemlerin uygulanma sürecine ilişkin görüşlerini ortaya çıkarmak amacıyla yapılan araştırmanın sonucunda hem matematik hem de sınıf öğretmenlerinin sıklıkla şekil çizme, muhakeme yapma ve problemi basitleştirme stratejilerini kullandıkları görülmektedir. Ancak sınıf öğretmenlerinin tahmin kontrol, bağıntı kurma ve deneme yanılma stratejilerini hemen hemen hiç kullanmadıkları araştırmadan açıkça görülmektedir. Öte yandan, öğretmenlerin tamamının rutin olmayan tarzdaki problemlerin sınıf içinde uygulanması konusunda olumlu görüşler bildirmeleri de yine araştırmadan elde edilen diğer önemli bir bulgudur. Bu bulgulardan yola çıkarak bu tür stratejilerin geliştirilmesine yönelik özellikle lisans düzeyinde eğitim verilmesi; ilköğretimden başlayarak matematik programlarında rutin olmayan problemlere daha fazla yer verilmesi önerilebilir.

KAYNAKLAR

- Altun, M. (2008). *Eğitim fakülteleri ve lise matematik öğretmenleri için liselerde matematik öğretimi*. Bursa: Alfa Aktüel Yayınevi.
- Altun, M. (2009). *Eğitim fakülteleri ve ilköğretim matematik öğretmenleri için matematik öğretimi*. Bursa: Erkam Matbacılık.
- Altun, M., Arslan, Ç (2006). İlköğretim öğrencilerinin problem çözme stratejilerini öğrenmeleri üzerine bir çalışma. *Uludağ Üniversitesi Eğitim Fakültesi Dergisi XIX (1), 2006, 1-21*.
- Anderson, J. (2009). Mathematics curriculum development and the role of problem solving. *The Australian Curriculum Studies Association's 2009 Biennial Conference (ACSA Conference)* Available from <http://www.acsa.edu.au/pages/images/judy%20anderson%20%20mathematics%20curriculum%20development.pdf>. 3/10/2013 tarihinde alınmıştır.
- Artut, P. D. ve Tarım, K. (2006). İlköğretim öğrencilerinin rutin olmayan sözel problemlerini çözme düzeylerinin, çözüm stratejilerinin ve hata türlerinin incelenmesi, *Çukurova Üniversitesi Sosyal Bilimler Dergisi, 15(2), 39-50*.
- Asman, D. & Markovits, Z. (2009). Elementary school teachers' knowledge and beliefs regarding non-routine problems. *Asia Pacific Journal of Education, 29(2)*, DOI: 10.1080/02188790902859012

- Bayazıt, İ. (2013). İlköğretim 7. ve 8. Sınıf Öğrencilerinin Gerçek-Yaşam Problemlerini Çözerken Sergiledikleri Yaklaşımlar ve Kullandıkları Strateji ve Modellerin İncelenmesi. *Kuram ve Uygulamada Eğitim Bilimleri*, 13(3) 1903-1927
- Blum, W., & Niss, M. (1991). Applied mathematical problem solving, modelling, and links to other subjects—State, trends and issues in mathematics instruction. *Educational Studies in Mathematics*, 22(1), 37-68.
- Çelebioğlu, B., Y. Yazgan(2009). İlköğretim Öğrencilerinin Bağını Bulma ve Sistematik Liste Yapma Strateji. *Uludağ Üniversitesi Eğitim Fakültesi Dergisi* XXII (1), 2009, 15-28
- Ho, K.. F. (2009). Two grade 5 teachers' enactment of mathematical problem solving and their classroom talk: Contrasting approaches. *Quaderni di Ricerca in Didattica (Matematica)*, Supplemento, 4-19. Available from http://math.unipa.it/~grim/TSG24_ICMI11_Ho_QRDM_Supl4_09.pdf. 1/10/2013 tarihinde alınmıştır.
- Inoue, N. (2005). The realistic reasons behind unrealistic solutions: The role of interpretive activity in word problem solving. *Learning and Instruction*, 15, 69-83.
- Kılıç, Ç. (2011). İlköğretim matematik öğretmen adaylarının standart olmayan sözel problemlere verdikleri yanıtlar ve yorumlar. *Ahi Evran Üniversitesi Eğitim Fakültesi Dergisi*, 2(3), 55-74.
- Laterell, C. M. (2013). What is problem solving ability? Available from http://www.lamath.org/journal/Vol1/What_IS_P_S_Ability.pdf. 10/8/2013 tarihinde alınmıştır.
- Lee, J., Kim, K. (2005). Elementary school teacher candidates' perception of good problems. IUMPST: The Journal 1. Available from <http://www.k-12prep.math.ttu.edu/journal/contentknowledge/lee01/article.pdf>. 3/8/2013 tarihinde alınmıştır.
- NCTM, (2000). *Principles and standards for school mathematics*. Reston, VA: National Council of Teachers of Mathematics.
- Polya, G. (1990). Nasıl çözmeli?(Çev. Feryal Halatçı). İstanbul: Sistem Yayıncılık.
- Reusser, K., & Stebler, R. (1997). Every word problem has a solution—The social rationality of mathematical modeling in schools. *Learning and Instruction*, 7(4). 339–359.
- Tertemiz, N., Çelik, Ö., Doğan, S. (2014). Sınıf öğretmeni adaylarının öğrenme stillerine göre kullandıkları problem çözme stratejileri. *Gazi Üniversitesi Endüstriyel Sanatlar Eğitim Fakültesi Dergisi*, 33, 9-23.
- Van de Walle, J. A. (2007). *Elementary and middle school mathematics: Teaching developmentally*. (6th ed.) Boston, MA: Pearson Education.
- Verschaffel, L., De Corte, E. (1997). Teaching Realistic Mathematical Modeling in the Elementary School: A Teaching Experiment with Fifth Graders. *Journal for Research in Mathematics Education*, 28, 577-601.
- Verschaffel, L., De Corte, E., Lasure, E., Van Vaerenbergh, G., Bogaerts, H., & Ratinckx, E. (1999). Learning to solve mathematical application problems: A design experiment with fifth graders. *Mathematical thinking and Learning*, 1, 195-229. http://dx.doi.org/10.1207/s15327833mtl0103_2
- Verschaffel, L., De Corte, E., & Borghart, I. (1997). Pre-service teachers' conceptions and beliefs about the role of real-world knowledge in mathematical modelling of school word problems. *Learning and Instruction*, 7(4). 339–359.
- Verschaffel, L., De Corte, E., & Lasure, S. (1994). Realistic considerations in mathematical modeling of school arithmetic word problems. *Learning and Instruction*, 4, 273-294.
- Xin, Z., Lin, C., Zhang, L. & Yan, R. (2007). The performance of Chinese primary school students on realistic arithmetic word problems. *Educational Psychology in Practice*, 23, 145–159.
- Yazgan, Y. (2007). Dördüncü ve beşinci sınıf öğrencilerinin rutin olmayan problem çözme stratejileriyle ilgili gözlemler, *İlköğretim Online Dergisi*, 6(2), 249-263.
- Yazgan, Y. ve Bintaş, J. (2005). İlköğretim dördüncü ve beşinci sınıf öğrencilerinin problem çözme stratejilerini kullanabilme düzeyleri: Bir öğretim deneyi, *Hacettepe Üniversitesi Eğitim Bilimleri Dergisi*, 28, 210-218.
- Yıldırım A. ve Şimşek H. (1999). *Sosyal bilimlerde nitel araştırma yöntemleri*, Ankara: Seçkin Yayınevi.
- Yoshida, H., Verschaffel, L., & De Corte, E. (1997). Realistic considerations in solving problematic word problems: do Japanese and Belgian children have the same difficulties?. *Learning and Instruction*, 7, 329-338.

EXPLORING THE RESULT OF THALES THEOREM AND ITS RELATIONSHIP TO OTHER SHAPES AMONG IRANIAN MATHEMATIC HIGH SCHOOL STUDENTS

Roghayeh AKHBARI

Zahra_akhbari@yahoo.com

Abstract: This paper sheds more lights on finding out a new methodology in teaching Thales theorem results and working with fractions in similarity to help students analyze Thales theorem and come up to some solutions with solving any problems related to the pieces of Cross Chords of Circle, Right Triangle and Right Trapezoid. In this regarding, I have come to a conclusion, from fourteen years of teaching experience in mathematics to Iranian high school students, that the best way could be starting from theorem statements to hypotheses as well as using properties of fractions. Therefore, in this study pre test-post test experimental design with control group was used and sample of the study was composed of 44 Iranian second graders at high school. It was concluded that meaningful differences in favor of experimental group and success in pre test-post test comparisons were obtained.

Keywords: Thales theorem results; fraction properties; similarity.

INTRODUCTION

Recently, there has been more emphasis upon teaching geometrical concepts and knowledge. The need has been increasing to establish a mathematics education in which students can relate the concepts to their own lives and to the other disciplines and which aims to have students acquire the basic skills and strategies at the high school (NCTM, 1991). One of the most important objectives of geometry education is to develop students' problem solving skills. These days in Iran most of the students have problem with Thales theorem concept especially in secondary school. In this study I will confine solving skills to just Thales theorem. In other words I am going to explore and find out how students deal with this problem and are able to find a better relationship between Thales theorem and other shapes in high school. The success of my Iranian students in geometry is going to be exploited in this paper. That is, this achievement highlights not only the academic achievements of the Iranian students but also their learning and teaching processes and methods.

Purpose of the study

In this research the aim was to examine the effect of a new teaching method supported by using geometry I book for Iranian high school student of the second grade. I have found this method useful for students especially in developing their attitudes, achievement and math intelligence.

METHOD

Design of the Experiment

In this study pre test-post test experimental design with control group was used to shed more lights on more reliable result. Therefore, this study is a quantitative one.

Sample of the Study

Research was carried out with students of second grade from two high schools in Mashhad. The participants were 44 second graders students in these schools. As you can see in table 1 the detailed information of the participants has been shown.

Table1. Participants Features

Variables		N
Group	1.	22
	2.	22
Age	16	
Gender	F	

TOTAL		44
-------	--	----

Procedural Way and Data Gathering Instruments

The achievements tests as pre and post test were prepared considering the two units in the second grade for two groups of students from two different majors; mathematics and experiential science. Control and experimental groups were randomly selected in HefdahShahrivar and Professor Reza high schools in Mashhad. It is nice to add that the pre-test was used to select two homogeneous groups for this study. In the following table, you can see the reliability as well as some other statistical information regarding both pre-test and post-test for both groups.

Table 2. One-Sample Kolmogorov-Smirnov Test

		Pre-test (Science)	Post-test (Science)	Pre-test (Math)	Post-test (Math)
N		22	22	22	22
Normal Parameters	Mean	9.6818	10.8295	12.2955	16.4432
	Std. Deviation	4.50276	3.61658	5.00870	3.21634
Most Extreme Differences	Absolute	.161	.100	.102	.134
	Positive	.161	.075	.062	.134
	Negative	-.124	-.100	-.102	-.127
Kolmogorov- Smirnov Z		.757	.469	.481	.630
Asymp. Sig. (2-tailed)		.616	.980	.975	.822
a. Test distribution is Normal.					

The Cronbach's Alpha reliability for all variables was 0.81.

Result and Conclusion

To describe the statistical information, first we refer to the students of control group (Science major). As the following table describes, the mean score for this group was 9.68 for the pre-test that was increased to 10.82 in the post-test.

Table 3. Descriptive Statistics

	N	Minimum	Maximum	Mean	Std. Deviation
Pre-Test	22	.00	19.50	9.6818	4.50276
Post-Test	22	3.25	17.00	10.8295	3.61658
Valid N (list wise)	22				

In addition, based on the following figure, about 59 percents of students possessed median score.

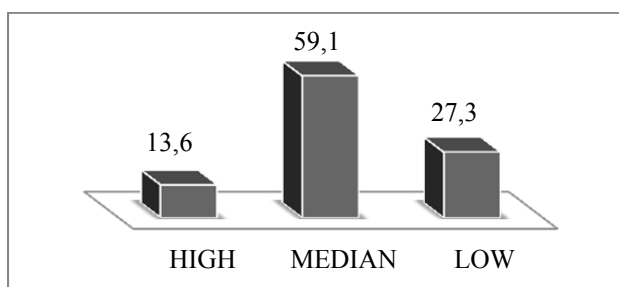

Figure1. Descriptive Statistics for Control Group (Pre-Test)

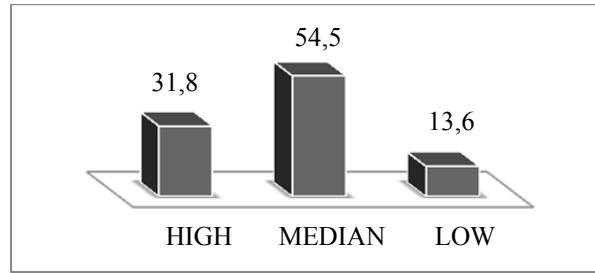

Figure2. Descriptive Statistics for Control Group (Post-Test)

After pair-t test, we could come to this conclusion that the mean score for this group was not significant

Table4. Paired Samples Test

		Paired Differences					t	df	Sig. (2-tailed)
		Mean	Std. Deviation	Std. Error Mean	95% Confidence Interval of the Difference				
					Lower	Upper			
Pair 1	Pre-post test	-1.14773	4.34704	.92679	-3.07510	.77964	-1.238	21	.229

Now, about the experimental group (Math major) the statistical information was elaborated in the following table.

Table5. Descriptive Statistics

	N	Minimum	Maximum	Mean	Std. Deviation
Pre-test	22	.00	20.00	12.2955	5.00870
Post-test	22	10.00	20.00	16.4432	3.21634
Valid N (list wise)	22				

The mean score for pre-test was 12.29 increased to 16.44 after taking the post-test.

Moreover, based on the figure came bellow, 54.5 percents of the students owned median score and 63.6 percents possessed high score.

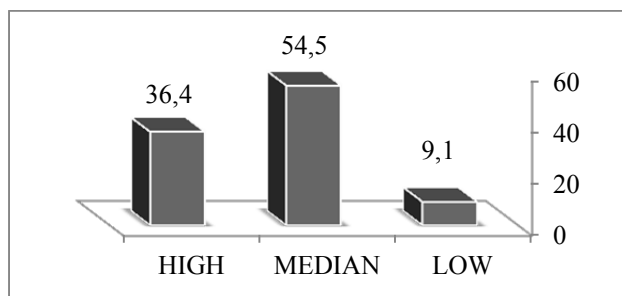

Figure3. Descriptive Statistics (Pre-Test)

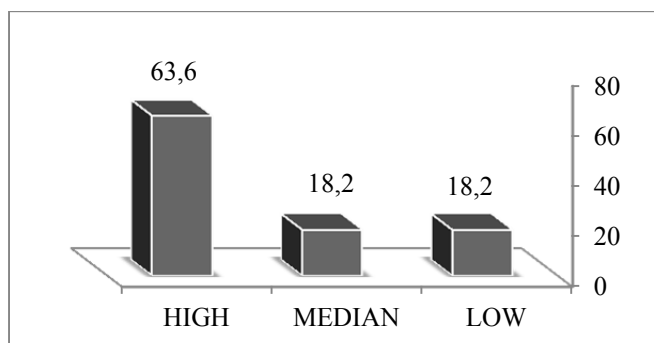

Figure4. Descriptive Statistics (Post-Test)

After pair-t test, we could come to this conclusion that the mean score for this group was significant.
P-value=0.02

Comparison of the Two Groups

Table6. Independent Samples Test

		Levene's Test for Equality of Variances		t-test for Equality of Means						
		F	Sig.	t	df	Sig. (2-tailed)	Mean Difference	Std. Error Difference	95% Confidence Interval of the Difference	
									Lower	Upper
VAR00001	Equal variances assumed	.760	.388	-1.820	42	.076	-2.61364	1.43594	-5.51147	.28420
	Equal variances not assumed			-1.820	41.533	.076	-2.61364	1.43594	-5.51244	.28516

Comparing these two groups together (control and experimental groups) lead us to this conclusion that for pre-test the difference was not significant. However, after post-test the mean scores of the students of the experimental group were considerably increased.

Table7.Pre-Test

VAR00002		N	Mean	Std. Deviation	Std. Error Mean
VAR00001	Science	22	9.6818	4.50276	.95999
	Math	22	12.2955	5.00870	1.06786

Table8. Post-Test

VAR00002		N	Mean	Std. Deviation	Std. Error Mean
	Science	22	10.8295	3.61658	.77106
	Math	22	16.4432	3.21634	.68573

In sum, I found this new method useful for the high school students and highly recommended to the teachers.

REFERENCES

- Bakhtiari, Javad. (1985). *Nature and Geometry of Hieroglyphics*.
- Dieudonne, J. (1981). The universal domination of geometry. *ZDM*, 13(1), 5-7.
- Discussion Document for an ICME Study (1994). Perspective on teaching of geometry for 21st century.
- Dukowski, L, & etal. (1988). *Mathematics 8*: Houghton Mifflin Canada Limited.
- Gooya, Zahra, Azad, Soheila Gholam, Niusha, Jafar, Zangane, Bijan Zohoori, Babaei, Javad Haji, & Poor, Rohollah Jahani. (2014). *Geometry I*.
- Hoechsmann, K. (1991). Lecture notes. *Mathematics Department, The University of British Columbia. Vancouver Canada*.
- Hoffer, A. (1981). Geometry is more than Proof. *Mathematics Teacher*, 74(1), 11-26.
- Jacobs, H.R. (1974). *Geometry*: W.H.Freeman & Company.
- Jacobs, H.R. (1982). *Mathematics, A Human Endeavor* (2nd ed.): W.H.Freeman & Company.
- Kalin, R, & Corbitt, M.K. (1990). *Geometry: Teachers' Edition*: Prentice Hall, N J.
- Kelly, B, Alexander, B, & Atkinson, P. (1987). *Mathematics 10*. Addison Wesley Pub. Ltd
- Kerr, D.R, JR. (1981). A geometry from National Assesment. *Mathematics Teacher*, 74(1), 27-32.
- Kline, M. (1974). *Why Johnny Can't add: The failure of the New Math.*: New york: Vintage Books.
- Lakatos, I. (1977). *Proofs and refutations: The loginc of mathematical discovery*: London: Cambridge University Press.
- Lang, S, & Murrow, G. (1988). *Geometry: A High School Course* (2nd ed.): Springer-Verlag.
- Moise, Edwin Evariste, & Downs, Floyd L. (1986). *Geometria moderna*: Addison-Wessley Iberoamericana.
- National Council of Teachers of Mathematics(NCTM). (1970). *A History of Mathematics Education in the United States and Canada*. Thirty Second year book. Author.
- National Council of Teachers of Mathematics(NCTM). (1985). *Secondary School Mathematics Curriculum: 1985 Year Book*. Edited by C.R.Hisch. Reston, VA: Author.

- National Council of Teachers of Mathematics(NCTM). (1987). *Learning and Teaching Geometry, K-12: 1987 Yearbook*. Edited by M.M. Lindquist. Reston, VA: Author.
- National Council of Teachers of Mathematics(NCTM). (1989). *Curriculum and Evaluation Standards for School Mathematics*. Reston, VA: Author.
- National Council of Teachers of Mathematics(NCTM). (1991). *Geometry from Multiple Perspectives*. Addison Series, Grades 9-12: Author.
- Robitaille, D.F. (1973). Why are we teaching high school Geometry? *Vector* 14(4), 13-22.
- Senk, S. (1989). Van Hiele levels and achievement in writing geometry proofs. *Journal of Research in Mathematics Education*, 20(3), 309.
- Steen, L. A.(ed). (1990). *On the shoulders of Giants: New approach to numeracy*: National Academy Press, Washington D.C.
- Stone, M. (1971). Learning and teaching axiomatic geometry. *Educational Studies in Mathematics*, 4, 91-103.
- Welchons, A. M, Krichenberger, W. R, & H.R, Pearson &. (1976). *Plane Geometry*: Ginn & Company

SOLVING A GEOMETRICAL EXERCISE FROM FOUR PERSPECTIVE

Roghayeh AKHBARI

Zahra_akhbari@yahoo.com

Abstract: This paper sheds more lights on finding four different ways for solving a geometrical exercise which refers to any Right trapezoid having two diagonal which are vertical and its altitude is geometry average between two bases of Right trapezoid. It is nice to mention that I have come up to these four solutions from fourteen years of teaching experience in mathematics and geometry to Iranian high school students. The first way is dividing the surface of two right triangles that exist in Right trapezoid. The three other ways can be analyzed by considering the different triangles in the trapezoid. The three other ways can be analyzed by considering the different triangles in the trapezoid. That is to say, we can change these similar triangles by considering three pairs of them. Finally this study puts more focus on this conclusion that teaching students these four different ways for solving such an exercise will provide more opportunities to have better digestion.

Keywords: Geometrical average; similarity; fraction properties; right triangle surface.

INTRODUCTION

Teaching geometry for the 21 ST century

In recent years geometry seems to have been lost large parts of its former central position in mathematics teaching in most countries. However, new trends have begun to counteract this tendency. There is an increasing awareness that geometry plays a key role in mathematics and learning mathematics. Although geometry has been eclipsed in the mathematics curriculum, research in geometry has blossomed as new ideas have arisen from inside mathematics and other disciplines, including computer science. Due to reassessment of the role of geometry, mathematics educators and mathematicians face new challenges (ICME, 1994).

Learning Teaching and teaching geometry

Teaching and learning geometry may seem just as difficult for teachers as it is for students. Geometry instruction begins as early as kindergarten, which may make it easier to teach this subject, because the lessons begin very simply. These lessons are added to gradually throughout the elementary years until geometry becomes a full-blown high school course. Take one concept at a time and use some of the tips found here to make geometry more comprehensive for teachers and their students (NCTM, 1987).

METHOD

In this study solving a special problem is explained which refers to any Right trapezoid having two diagonal which are vertical and its altitude is geometry average between two bases of Right trapezoid. For more clarification, an example has been mentioned in the appendix. The following solutions are based on the example.

First Way

The first way is dividing the surface of two right triangles that exist in Right trapezoid. Calculating the area T of a triangle is an elementary problem encountered often in many different situations. The best known and simplest

$$T = \frac{1}{2}bh$$

Where b is the length of the base of the triangle, and h is the height or altitude of the triangle. The term "base" denotes any side, and "height" denotes the length of a perpendicular from the vertex opposite the side onto the line containing the side itself (Geometry I, 2014).

The first solution refers to dividing the surface of two right triangles that exist in Right trapezoid. As it can be clearly seen in the example, we have two right triangles which named ABC and ADC. If we divide their surfaces and use similarity, we will come to the statement.

Second Way

As it's known ABD triangle is similar to ADC, therefore, as the second solution, after writing similarity's ratio and multiplying two of them to each other the statement will be proved.(Fraction properties is used).

Third Way

For the next solution, we use the transitivity between similar triangles and mix it with fraction properties .Moreover; we use a new triangle which is named ODC which is similar to ABD, so we can reach to our statement. (For more elaboration refer to Appendix).

Fourth Way

There is a well-known theorem to which the sum of interior angles of every triangle is equal to 180 degree. For the forth solution we use its properties for proving that the similarity between ABD triangle and ADC triangle. Based on this solution, these two triangles are similar to each other which is different from the three others. Consequently, multiplying the similar fractions lead us to the statement. (To get the example you can refer to the appendix).

CONCLUSION

In sum, I have come up with these methods to this conclusion that they can be used in geometry classes in order to help the students to get better understanding and better conception over this type of exercises.

REFERENCES

- Bakhtiari, Javad. (1985). *Nature and Geometry of Hieroglyphics*.
- Dieudonne, J. (1981). The universal domination of geometry. *ZDM*, 13(1), 5-7.
- Discussion Document for an ICME Study (1994). Perspective on teaching of geometry for 21st century.
- Dukowski, L, & etal. (1988). *Mathematics 8*: Houghton Mifflin Canada Limited.
- Gooya, Zahra, Azad, Soheila Gholam, Niusha, Jafar, Zangane, Bijan Zohoori, Babaei, Javad Haji, & Poor, Rohollah Jahani. (2014). *Geometry I*.
- Hoechsmann, K. (1991). Lecture notes. *Mathematics Department, The University of British Columbia. Vancouver Canada*.
- Hoffer, A. (1981). Geometry is more than Proof. *Mathematics Teacher*, 74(1), 11-26.
- Jacobs, H.R. (1974). *Geometry*: W.H.Freeman & Company.
- Jacobs, H.R. (1982). *Mathematics, A Human Endeavor* (2nd ed.): W.H.Freeman & Company.
- Kalin, R, & Corbitt, M.K. (1990). *Geometry: Teachers' Edition*: Prentice Hall, N J.
- Kelly, B, Alexander, B, & Atkinson, P. (1987). *Mathematics 10*. Addison Wesley Pub. Ltd
- Kerr, D.R, JR. (1981). A geometry from National Assesment. *Mathematics Teacher*, 74(1), 27-32.
- Kline, M. (1974). *Why Johnny Can't add: The failure of the New Math.*: New york: Vintage Books.
- Lakatos, I. (1977). *Proofs and refutations: The loginc of mathematical discovery*: London: Cambridge University Press.
- Lang, S, & Murrow, G. (1988). *Geometry: A High School Course* (2nd ed.): Springer-Verlag.
- Moise, Edwin Evariste, & Downs, Floyd L. (1986). *Geometria moderna*: Addison-Wessley Iberoamericana.
- National Council of Teachers of Mathematics(NCTM). (1970). *A History of Mathematics Education in the United States and Canada*. Thirty Second year book. Author.
- National Council of Teachers of Mathematics(NCTM). (1985). *Secondary School Mathematics Curriculum: 1985 Year Book*. Edited by C.R.Hisch. Reston, VA: Author.
- National Council of Teachers of Mathematics(NCTM). (1987). *Leraning and Teaching Geometry, K-12: 1987 Yearbook*. Edited by M.M. Lindquist. Reston, VA: Author.
- National Council of Teachers of Mathematics(NCTM). (1989). *Curriculum and Evaluation Standards for School Mathematics*. Reston, VA: Author.

National Council of Teachers of Mathematics(NCTM). (1991). *Geometry from Multiple Perspectives*. Addena Series, Grades 9-12: Author.

Robitaille, D.F. (1973). Why are we teaching high school Geometry? *Vector 14*(4), 13-22.

Senk, S. (1989). Van Hiele levels and achievement in writing geometry proofs. *Journal of Research in Mathematics Education*, 20(3), 309.

Steen, L. A.(ed). (1990). *On the shoulders of Giants: New approach to numeracy*: National Academy Press, Washington D.C.

Stone, M. (1971). Learning and teaching axiomatic geometry. *Educational Studies in Mathematics*, 4, 91-103.

Welchons, A. M, Krichenberger, W. R, & H.R, Pearson &. (1976). *Plane Geometry*: Ginn & Company.

APPENDIX

First Way

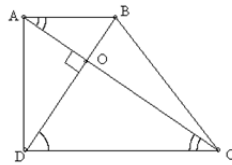

$$S_{\triangle ABD} = \frac{AB \cdot AD}{2}$$

$$S'_{\triangle ADC} = \frac{DC \cdot AD}{2}$$

$$\frac{S}{S'} = \frac{\frac{AB \cdot AD}{2}}{\frac{DC \cdot AD}{2}} = \frac{2(AB \cdot AD)}{2(DC \cdot AD)} = \frac{AB}{DC} *$$

$$\left. \begin{array}{l} \hat{A} = \hat{D} = 90^\circ \\ \frac{AD}{AD} = 1 \end{array} \right\} \Rightarrow \triangle ABD \sim \triangle ADC \Rightarrow \frac{AD}{DC} = \frac{BA}{AD} = \frac{BD}{AC} = K$$

$$\text{On the other hand: } * \Rightarrow \frac{S}{S'} = K^2 \Rightarrow \frac{AB}{DC} = \left(\frac{AD}{DC}\right)^2 \Rightarrow \frac{AB}{1} = \frac{AD^2}{DC} \Rightarrow AD^2 = AB \cdot DC$$

Second Way

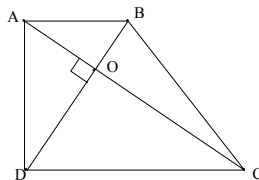

$$\left. \begin{array}{l} \hat{A} = \hat{D} = 90^\circ \\ \frac{AD}{AD} = 1 \end{array} \right\} \Rightarrow \triangle ABD \sim \triangle ADC \Rightarrow \left[\frac{AD}{DC} = \frac{AB}{AD} \right] = \frac{BD}{AC} \Rightarrow AD^2 = AB \cdot DC$$

Third Way

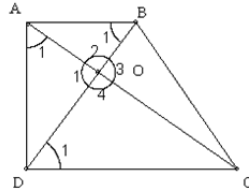

$$\left. \begin{array}{l} \widehat{O}_1 = \widehat{D} = 90 \\ \widehat{A}_1 = \widehat{A}_1 (\text{common}) \end{array} \right\} \Rightarrow \triangle ADC \sim \triangle AOD *$$

$$*\Rightarrow \frac{AD}{AC} = \frac{AO}{AD} = \frac{OD}{DC} \Rightarrow AD^2 = AC \cdot AO **$$

$$\left. \begin{array}{l} \text{First Way} \Rightarrow \triangle ABD \sim \triangle ADC \\ ** \Rightarrow \triangle ADC \sim \triangle AOD \end{array} \right\} \Rightarrow \triangle ABD \sim \triangle AOD \Rightarrow \frac{BD}{AD} = \frac{AD}{OD} = \frac{AB}{AO} \Rightarrow AD^2 = BD \cdot OD ***$$

$$** \ \& \ *** \Rightarrow BD \cdot OD = AO \cdot AC$$

$$\left. \begin{array}{l} AB \parallel DC, BD(\text{diagonal or oblique}) \Rightarrow \widehat{B}_1 = \widehat{D}_1 \\ \widehat{A} = \widehat{O}_4 = 90 \end{array} \right\} \Rightarrow \triangle ABD \sim \triangle ODC \Rightarrow \frac{BD}{DC} = \frac{AB}{OD} = \frac{AD}{OC} \Rightarrow BD \cdot OD = AB \cdot DC ****$$

$$*** \ \& \ **** \Rightarrow AD^2 = AB \cdot DC$$

Fourth Way

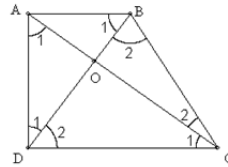

$$\left. \begin{array}{l} \widehat{A} = \widehat{D} = 90 \\ \widehat{B}_1 + \widehat{D}_1 = \widehat{A}_1 + \widehat{D}_1 = 90 \Rightarrow \widehat{B}_1 = \widehat{A}_1 \end{array} \right\} \Rightarrow \triangle ABD \sim \triangle ADC \Rightarrow \frac{AD}{DC} = \frac{AB}{AD} = \frac{BD}{AC} \Rightarrow AD^2 = AB \cdot DC$$

A SOFTWARE SIMULATION FOR MULTI-CHANNELS WDM BY HYBRID EDFA/RA SYSTEM

Essa Ibrahim ESSA

Department Computer Science, College of Computer Sc. and Math., Tikrit University, Salah AL-Deen, Iraq.
E-mail: essaibrahimessa@yahoo.com

ABSTRACT: In this paper we provide a software simulation to enhancement performance system using hybrid Erbium doped fiber amplifier EDFA/RA, by the way Raman amplifiers (RA) provides a continuous amplification along the fiber. The ($8 \times 10\text{Gb/s}$) wavelength division multiplexing (WDM) system show successful transmitter work at (1552.52, 1551.72, 1550.92, 1550.12, 1549.32, 1548.51, 1547.72, 1546.92nm) all input channels have the same power with (-6.6666dBm) these signal are amplified through EDFA and RA of (20km), two pump laser used with wavelength and power is (1450nm, and 800nm, 980nm, and 100mw) respectively. The total output signal is (29.3643dBm), total output noise is (-13.5326dBm), and output optical-signal-to-noise ratio (OSNR) is (0dB). The average maximum Q-factor for all 8-channels is (4.7962), and the average of minimum BER is 3×10^{-7} . This mean the optical network is exploiting for high speed network communication with low error rate, and the major contribution is the development of the multi-destination communication over the lightwave WDM system. The system is simulated, tested, and verified using OptiSystem Software Package.

Key words- EDFA, RA, pump laser, WDM, OSNR, and BER.

INTRODUCTION

The Stimulated Raman scattering (SRS) nonlinearities with optical fiber provide an optical amplification process. To development of transparent optical amplifier the erbium doped fiber amplifier (EDFA) technology are adopted the amplification modules are placed after 40-50km of link, this due to initial power and attenuated signal after propagate it in fiber, Raman effect is a scattering effect of light. Light scattering occurs as a consequence of fluctuations in optical properties of a medium. There are three types of scattering: (Rayleigh, Brillouin, and Raman scattering) (Agrawal G. P. (2002)).

The main features of the Raman amplifier (RA) is continuous amplification along the fiber, bidirectional in nature are offers more stability, insensitivity to reflections (Aoki Y. et al. (1988)). The use of RA allows the confinement of the signal inside the limits imposed by the signal-to-noise-ratio (SNR) degradation as a result from higher link distances this is an advantage of the distributed Raman over lumped amplification (André P.S. & et. al. (2007) & Emori Y. & et al. (2002)). As the traffic increases, wavelength division multiplexing (WDM) technology arises to expand transmission capacity, in turn, requires flexible and broadband architectures with enforcement the interest in RA (ITU-T G.694.1. (2002)).

To amplify an optical signal with a conventional repeater, one performs photon to electron conversion, electrical amplification, retiming, pulse reshaping, and then electron to photon conversion. These processes are work well in single wavelength systems, but at high speed optical network can adopted all-optical amplifiers such as EDFA, and RA to overcome conversion from electrical-to-optical and vice-versa (Wasfi M. (2009)).

Whereas an EDFA requires a specially constructed optical fiber for its operation, the input powers to EDFA vary as slowly as their gain relaxation time in WDM networks because wavelength channels which pass through the EDFA can change as a result of network configurations or any other partial failure (Ellis A. D. & et.al. (1994)). To implement RA using optical fiber as gain medium requires that the pump and information signals must be injected into the same fiber. A basic scheme for RA architecture is illustrated in Figure 1.

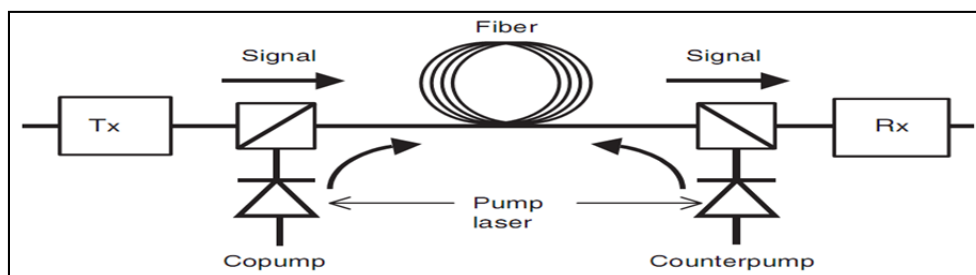

Figure 1: Optical Communication System Employing Raman Amplification.

In general approach the power evolution of pumps signals and amplified spontaneous emission (ASE) in forward and backward directions with time along the fiber distance is given by the following set of equations (Agrawal G. P. (1995) & Karasek M. & et.al. (2004)):

$$\frac{dP_s}{dz} = g_R P_p - \alpha_s P_s \dots (1)$$

and

$$\mp \frac{dP_p}{dz} = -\frac{\omega_p}{\omega_s} g_R P_p P_s - \alpha_p P_p \dots (2)$$

Where g_R ($W^{-1}m^{-1}$) is the Raman gain coefficient of the fiber α_s and α_p are the attenuation coefficient at signal and pump wavelength respectively, ω_s and ω_p are the angular frequencies of the signal and pump, P_s and P_p are signal power and pump power.

By integration Eq. 1 to obtain Eq. 3

$$P_s(L) = G(L)P_{s(0)} \dots (3)$$

Where $G(L)$ is the signal gain, L is the amplifier length.

The relation between on-off Raman gain and the Raman gain efficiency is given as (Agrawal G. P. (1995)):

$$G_A = \frac{P_s(L)\text{with pump on}}{P_s(L)\text{with pump off}} \dots (4)$$

The noise figure can be calculated as:

$$NF (dB) = 10 \log \left(\frac{S_{in}/S_{in}}{S_{out}/N_{out}} \right) \dots (5)$$

Amplifier spacing has opposite effects on noise generated due to the fiber nonlinearities effects SRS, four wave mixing (FWM), and the ASE noise introduced by in-line optical amplifications. Decreasing in the amplifier spacing the SRS and FWM effects increase, while the ASE noise reduces (Mohammed A. A. & et. al. (2009) & Kaur G. & et. al. (2009)).

Based on the nature of Raman physics it has many advantages: (i): Raman gain exist in every fiber that is mean existing link can be upgrade even though they are already installed, (ii): gain is available over the fiber ranging from 0.3 to 2 microns, and (iii): RA is that the gain spectrum can be tailored by adjusting the pump wavelengths, multiple pump can be use to increase the optical bandwidth (Islam M. N. (2004), Seo H. S. & et. al. (2004) & Headley C. & Agrawal G. P. (2005)). The major contribution of this work is to development the multi-destination communication over the lightwave WDM system by hybrid EDFA/RA. Section II illustrate the simulation model, section III present some results and general discussion, and finally, section IV demonstrate some conclusions and suggested possible for future works.

SIMULATION MODEL

The system simulation consists of three main parts: (i) optical transmitter, (ii) optical transmission link, and (iii) optical receiver. In the following subsections we demonstrate them in details. Our simulation are designed, tested, and verified using OptiSystem software package it is Canadian corporation license product (Optisystem. (2007)).

The first component of transmitter is the WDM transmitter with 8-channels with frequencies of (193.1THz, to 193.8THz), frequency spacing is 100GHz, power is -6.6666dBm, and modulation format is NRZ, all channels are multiplexed by 8×1 equal spacing multiplexer with frequency of 193.1THz, frequency spacing is 100GHz, and bandwidth is 10GHz, then the output signal from multiplexer are entered into the transmission link to post-amplified as booster by EDFA with gain of 10dB, and noise figure is 6dB, after amplification process the optical signal lunched into the Raman amplifier (RA) the main properties of it are length with 20km, attenuation is 0.2dB/km, effective interaction area is $55\mu m^2$, Raman gain peak is 9.5×10^{-14} , Raman gain reference pump is 1000nm, temperature is 300k, polarization factor is 2, Rayleigh back scattering is $5 \times 10^{-5} 1/km$, upper pump reference is 1500nm, noise center frequency is 1540nm, noise bandwidth is 80nm, noise bins spacing is 4nm, noise threshold is -100dB, and noise dynamic is 3dB, the backward pump laser with frequency of 1450nm, and power is 800nm, also the signal after RA are pre-amplified to aim to place a large signal at the receiver by EDFA with gain of 10dB, and noise figure is 6dB, the power combiner 2 × 1 used to combine two signal (origin, and pump laser signal with frequency of 980nm, and power is 100mw), after round trip signal are entered into the WDM equal spacing demultiplexer of 1 × 8 with frequency of 193.1THz, frequency spacing is 100GHz, and bandwidth is 10GHz. After demultiplexing process each signal are separate on its port, and filtered by Bessel optical filter with frequency of 193.1THz, bandwidth is 10GHz, insertion loss is 0dB, depth is 100dB, and order of 1, then at the receiver side are detected by optical receiver with positive intrinsic diode (PIN), and

filtered by low pass filter with depth of 100dB, order is 4, add-signal-noise, add ASE noise, add shot noise, add thermal noise, and thermal noise is 1×10^{-22} , and finally each signal are monitored by bit error rate (BER) analyzer to calculate Q-factor, and minimum BER. The bit rate of this simulation is 10Gb/s, sequence length is 128bits, sample per bit is 64, and number of samples is 8192. The schematic diagram for the hybrid EDFA/RA simulation is shown in Figure 2.

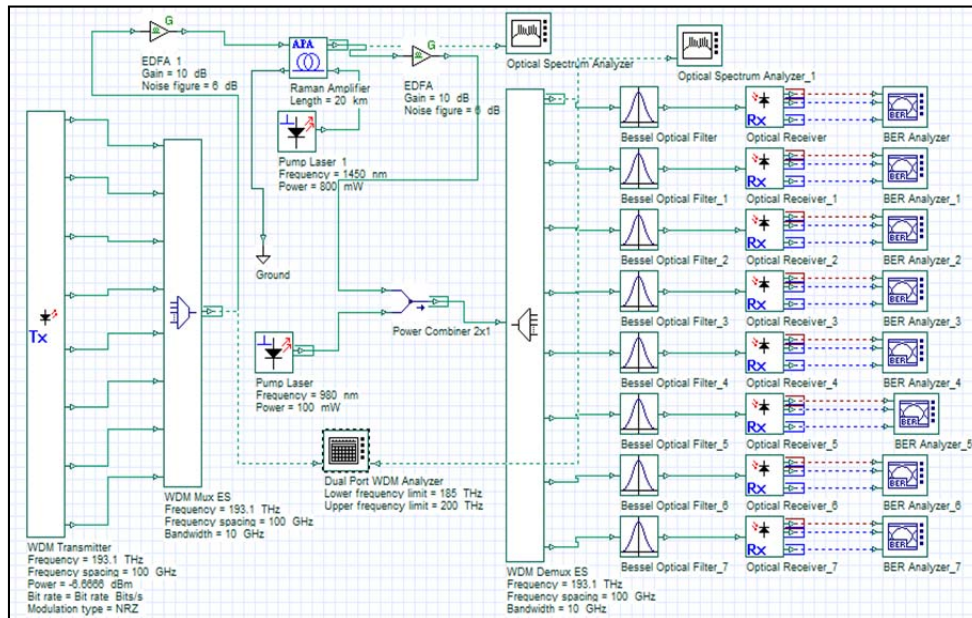

Figure 2: The Schematic Diagram For Hybrid EDFA/RA System.

RESULTS AND GENERAL DISCUSSION

The numerical data (set of controlling parameters) of our system model are employed to obtain the performance of multi-pumped, Raman amplifiers, and EDFA in WDM optical networks as to improve the OSNR, and reduce the nonlinear effects in transmission system. Through Fig. “3” to Fig. “14” will be demonstrating some results of this work:

- 1) Fig. “3”: show all input signal spectrum before launched into the transmission link.
- 2) Fig. “4”: illustrate all signals after RA, red color (signal), and green (noise).
- 3) Fig. “5”: show Raman gain versus frequency, the high peak appear between 10THz and 20THz.
- 4) Fig. “6”: demonstrate output signal (193.1THz) after demultiplexer, there are some noise added by amplifiers.
- 5) Fig. “7”: gain (dB) versus wavelength iteration for all channels (gain increase when wavelength increases).
- 6) Fig. “8”: show noise figure (NF) (dBm) versus wavelength for all signals (NF decrease when wavelength increase).
- 7) Fig. “9”: demonstrate power (dBm) versus wavelength iteration (power increase when wavelength increases).
- 8) Fig. “10”: output channels power versus wavelength, there is some degradation in power this is due to nonlinearities problem.
- 9) Fig. “11”: show Q-factor for output channel_1 (193.1THz) from BER analyzer.
- 10) Fig. “12”: show the minimum BER for the output channel_1 from BER analyzer.
- 11) Fig. “13”: show Q-factor for output channel_8 (193.8THz) from BER analyzer.
- 12) Fig. “14”: show the minimum BER for the output channel_8 from BER analyzer.

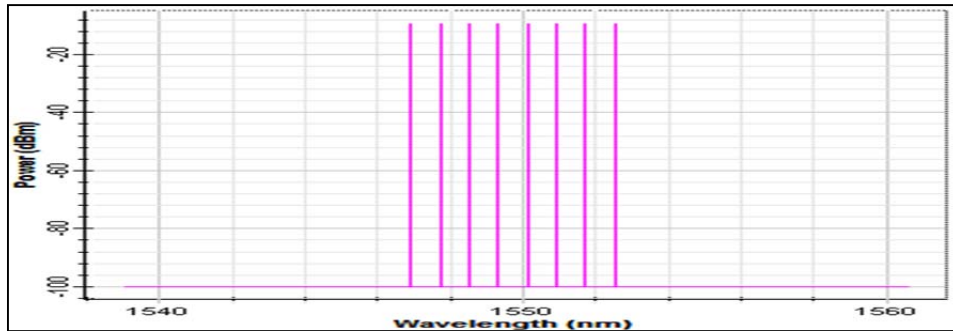

Figure 3: Input Spectrum Signal Iteration.

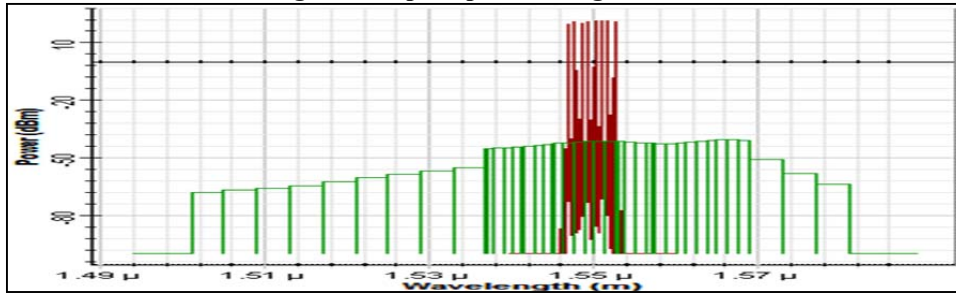

Figure 4: All Signals After RA From OSA.

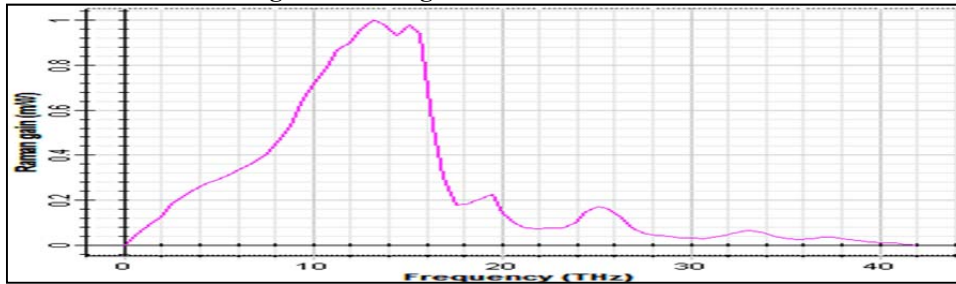

Figure 5: Raman Gain Versus Frequency.

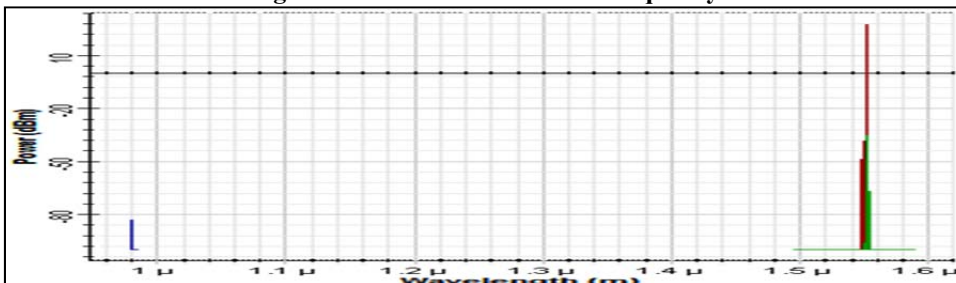

Figure 6: Output Signal (193.1THz) After Demultiplexer From OSA_1.

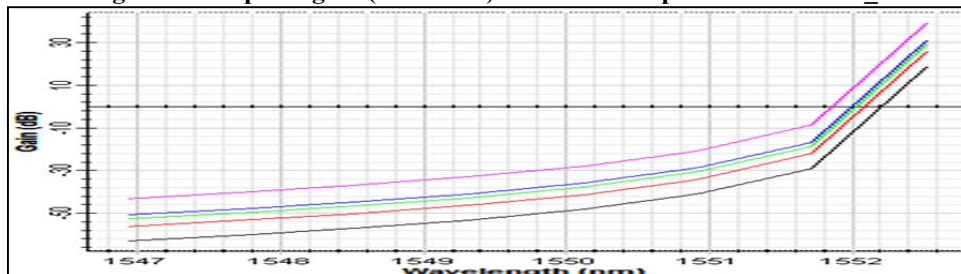

Figure 7: Gain Versus Wavelength Iteration

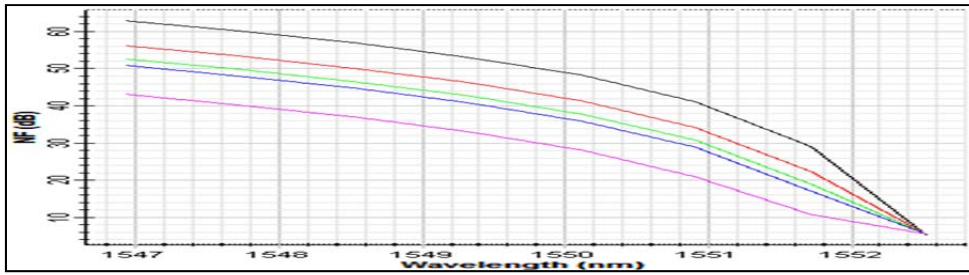

Figure 8: Noise Figure Versus Wavelength Iteration.

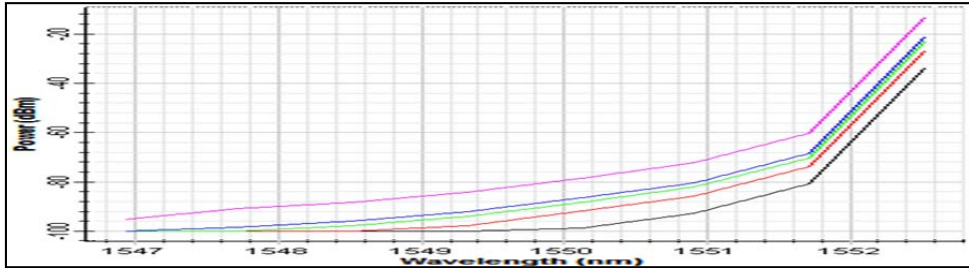

Figure 9: Output Noise Spectrum Iteration

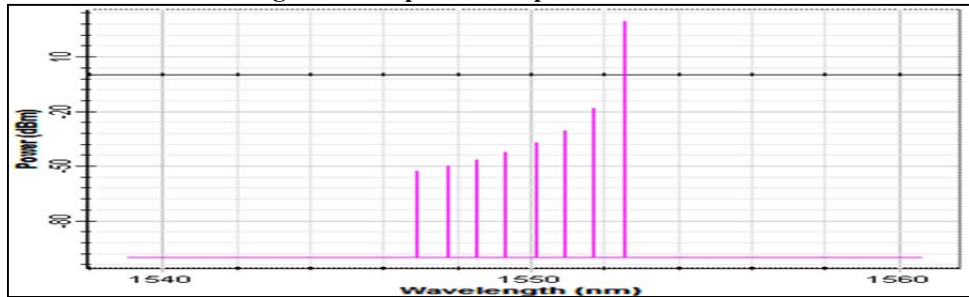

Figure 10: Output Signal Spectrum Iteration.

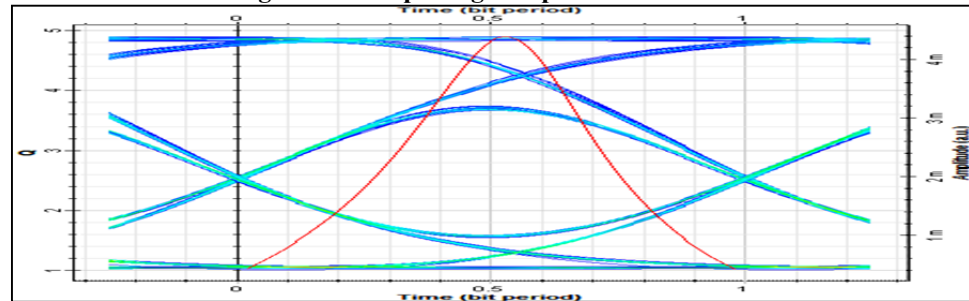

Figure 11: Q-Factor For The Output Channel_1 (193.1THz) From BER Analyzer.

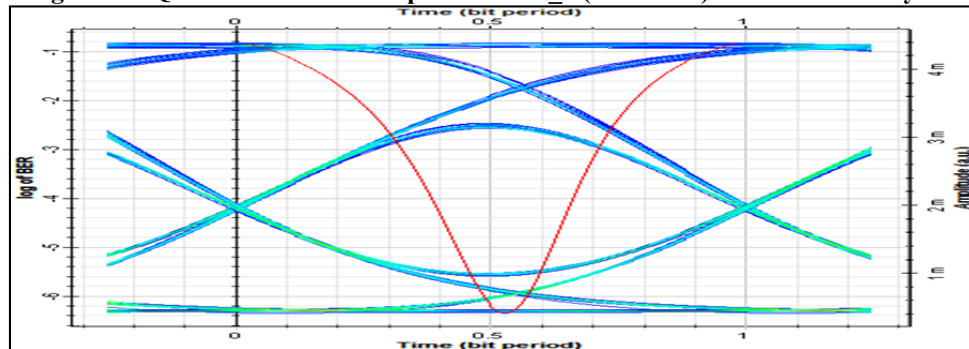

Figure 12: Minimum BER For The Output Channel_1 (193.1THz) From BER Analyzer.

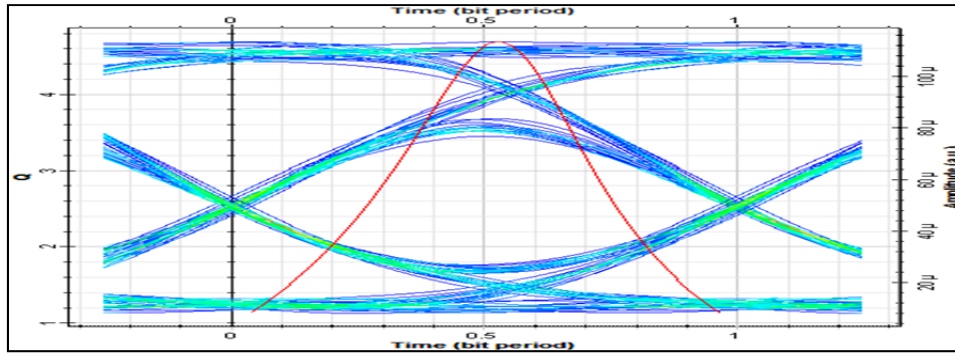

Figure 13: Q-Factor For The Output Channel_8 (193.8THz) From BER Analyzer_7.

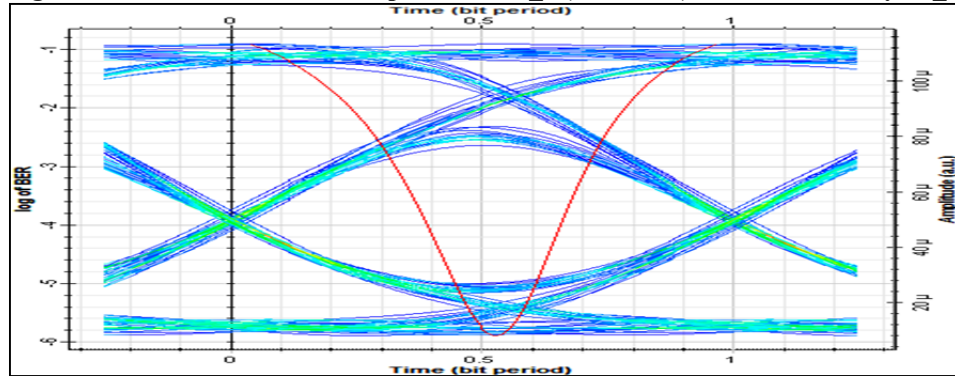

Figure 14: Minimum BER For The Output Channel_8 (193.8THz) From BER Analyzer_7.

From the dual port WDM analyzer the total output signal is 29.3643dBm, and ratio Max/Min is 82.101, the total output noise is -13.5326dBm, and ratio Max/Min is 81.7984 and the total output OSNR is 0dB, and the ratio Max/Min is 81.7984.

CONCLUSION

Through this paper there are simulated systems of 8×10 Gb/s WDM transmission over 20km of RA with EDFA. The main benefit of this work is to use hybrid amplification process over WDM optical communication network. To reduce the fiber nonlinearities the NRZ format was adopted. The gain of multi-pumped RA in WDM is affected by two important parameters (wavelength, and power). The EDFA/RA improves the OSNR this lead to maximum bit rate or capacity over optical network. The average maximum Q-factor for all 8-channels is 4.7962, and the average of minimum BER is 3×10^{-7} . No architecture changes were needs for the existing infrastructure. Also, can be modified this work to involve network reconfiguration by add optical add-drop multiplexer (OADM), or discrete RA.

REFERENCES

- Agrawal G. P. (1995). *Fiber Optic Nonlinearities*. Academic Press.
- Agrawal G. P. (2002). *Fiber Optic Communication Systems*. Third Edition, Wiley- Interscience. A John Wiley & Sons. Inc. Publication.
- André P. S., Pinto A. N., Teixeira A. L. J., Neto B., Stevan J., Sperti D., Rocha F., Bernardo M., Pinto J. L., Fugihara M., Rocha A., & Facao M. (2007). New Challenges In Raman Amplification For Fiber Communication Systems. Nova Science Publishers, Inc. ISBN: 1-60021-866-0. 51-81.
- Aoki Y. (1988). Properties of Fiber Raman Amplification and Their Applicability to Digital Optical Communication System. *Lightwave Technology Journal*. Vol. 6, No. 7. 1225-1239.
- Ellis A. D., Widdowson T., Shan X. & Moodie D. G. (1994). Three Node 40Gb/s OTDM Network Demonstration Using Electro-Optic Switches. *IEEE Electron Letters*, Vol. 30, No. 16. 1333-1334.
- Emori Y., Kado S. & Namiki S. (2002). Broadband Flat-gain and Low-noise Raman Amplifiers Pumped by Wavelength-Multiplexed High Power Laser Diodes. *Optics Fiber Technology*, Vol.8, No. 107.
- Headley C. & Agrawal G. P. (2005). *Raman Amplification in Fiber Optical Communication Systems*. Elsevier Academic Press.
- Islam M. N. (2004). *Raman Amplifiers for Telecommunications 1 Physical Principles*. Springer.
- ITU-T G.694.1. (2002). <http://www.itu.org/>.

- Karasek M., Kanka J., Honzatko P., & Peterka P. (2004). Time domain simulation of power transients in Raman fiber amplifiers. *International Journal Numerical Modeling: Electronic Network, Devices, and Fields*. Vol. 17, Issue 2, 165-176
- Kaur G., Singh M. L. & Patterh M. S. (2009). Simulation of 10Gb/s DWDM Transmission System in the Presence of Optical Nonlinearities . *International Conference on Optics and Photonics, Chandigarh, India*, 30 Oct.
- Mohammed A. A., Saad A. A., Rashed A. N. & Eid M. M. (2009). Characteristics of Multi Pumped Raman Amplifiers in Dense Wavelength Division Multiplexing (DWDM) Optical Access Networks. *IJCSNS International Journal of Computer Science and Network Security*, Vol.9 No.2, February.
- Optisystem. (2007). <http://www.optiwave.com/>.
- Seo H. S., Ghio Y. G. & Kim K. H. (2004). Design of transmission optical fiber with a high Raman gain, large effective area, low nonlinearity, and low double Raleigh back scattering. *IEEE Photonic Technology Letters*, Vol. 16, January.
- Wasfi M. (2009). Optical Fiber Amplifiers-Review. *International Journal of Communication Networks and Information Security (IJCNIS)* ,Vol. No. 1.

İLKÖĞRETİM MATEMATİK ÖĞRETMEN ADAYLARININ MATEMATİK TARİHİNİN MATEMATİK EĞİTİMİNDE KULLANILMASINA YÖNELİK TUTUM VE İNANÇLARI

PROSPECTIVE MATHEMATICS TEACHERS' ATTITUDES AND BELIEFS TOWARDS USING MATHEMATICS HISTORY IN MATHEMATICS EDUCATION

Muhammet KAŞIKÇI
Dokuz Eylül Üniversitesi
mami_647@hotmail.com

Serkan NARLI
Dokuz Eylül Üniversitesi
Serkan.narli@deu.edu.tr

Mustafa AKDEMİR
Dokuz Eylül Üniversitesi
akdemir368@gmail.com

ÖZET: Bu çalışmanın amacı öğretmen adaylarının matematik tarihinin matematik eğitiminde kullanılmasına yönelik tutum ve inanışlarını belirlemek ve cinsiyet, sınıf ve mezun olunan lise türü değişkenleri açısından tutum ve inanç ortalama puanlarını incelemektir. Bu amaçla 2013-2014 eğitim öğretim yılı güz döneminde Dokuz Eylül Üniversitesi Eğitim Fakültesi İlköğretim Matematik Öğretmenliği programında okuyan toplam 208 öğretmen adayı ile betimsel bir çalışma yürütülmüştür. Çalışmada veriler Alpaslan (2011)' e ait "Matematik Tarihinin Matematik Eğitiminde Kullanılmasına yönelik Tutum ve İnanışlar Anketi" ile elde edilmiştir. Bulgularda matematik öğretmen adaylarının tutum ve inanç ortalama puanlarının yüksek olduğu tespit edilmiştir. Matematik öğretmen adaylarının tutum ve inanç ortalama puanlarının cinsiyete göre farklılık göstermediği ancak sınıf düzeyleri açısından ortalama puanlarda anlamlı bir farkın olduğu anlaşılmıştır. Matematik öğretmen adaylarının matematik tarihinin matematik eğitiminde kullanılmasına yönelik tutum ve inançları başka değişkenler açısından da incelenebilir ve olumsuz tutum geliştiren adayların bu tutumlarının altında yatan nedenler araştırılabilir.

Anahtar sözcükler: matematik tarihi, tutum ve inanç, matematik öğretmen adayı, matematik eğitimi

ABSTRACT: The aim of this descriptive study is to assess the prospective mathematics teachers' attitudes and beliefs towards using mathematics history in mathematics education and to search possible effect of gender, type of the high school graduated from and grade of prospective teachers on the average scores of attitudes and beliefs test. To gain information, we implemented a questionnaire to 208 prospective teachers from Dokuz Eylül University in first semester of 2013-2014 education year. We used "Attitudes and Beliefs towards Use of History of Mathematics in Mathematics Education Questionnaire" as data collection instrument. This questionnaire belongs to Alpaslan (2011). Findings tell us that scores were high and there were no difference created by gender. On the contrary, level of the year - grade- made a significant difference on average scores. The prospective mathematics teachers' attitudes and beliefs could be examined with other variables and it could be searched why some prospective teachers have negative viewpoint.

Key words: mathematics history, attitudes and beliefs, prospective mathematics teacher, mathematics education

GİRİŞ

Matematik dersi bir çok öğrenci tarafından zor, anlaşılmaz, nerden geldiğini anlamadığı pek çok terimle dolu ve kendisine sıkıntı veren bir ders olarak görülmektedir. Pek çok öğrenci matematik dersini okulu bitirince

kurtulacağı bir sorun olarak görmekte, ancak bazı öğrenciler de matematik dersini sevebilmektedir(Sertöz, 2002). Buradan çıkarılabileceği üzere matematiği sevmeyen öğrencilerin olduğu aşikardır. Ortaokullar matematik öğretim programının genel amaçlarından biri de matematiğe karşı olumlu tutumlar geliştirmiş ve matematik alanında özgüvenli bireyler yetiştirmektir(MEB-2013).

Matematik dersine motive etmek, problem çözmeye becerilerini geliştirmek ve matematiksel kavramların anlaşılabilirliğini artırmak kaliteli bir matematik eğitimin amaçları arasında yer alır. Bu amaçlar arasında yer alan matematiğe karşı motivasyonu arttırmak için somut materyallerden, oyunlardan faydalanılabilir ve matematiksel kavramların tarihi gelişiminden ve tarihi kişiliklerden bahsedilebilir (Yenilmez, 2011).

Tarih ile matematik birbirinden ayrı çalışma alanları gibi gözükebilir. Ancak, matematik öğreniminde geçmişteki uygulamaları öğrenmek matematik alanındaki çalışmalara ilham kaynağı olmaktadır. Teoremleri ortaya atan bilim insanlarının, teoremlerin bulunuş hikayelerinin, o tarihteki yaşam biçimi ve geçmişteki insanların matematikle olan etkileşimlerinin öğrenilmesi matematik alanında çalışanlar için motivasyon kaynağı olmaktadır. Yine matematik tarihi eğitimi, matematik dersine yönelik farklı bir bakış açısı sağlamakta, farklı öğretim tekniklerine esin kaynağı olmaktadır. Matematik tarihi, kullanımı derslerde göz ardı edilebilen kütüphane çalışmalarının ve planlı yazma alışkanlıklarının destekleyicisi olmaktadır [Fauvel, Keynes & van Maanen (2000); Gürsoy (2010); Furinghetti (2000)].

Bidwell (1993)' e göre matematik tarihini öğrencilerle tanıştırmak, öğrencileri matematik adasından kurtarıp insanları duygularla dolu, canlı ve ilginç bir hayatın olduğu matematik ana karasına çıkartmak gibidir. Matematik tarihi, matematiği insancılaştırır (Bidwell, 1993). Yani matematik, soyut kavramlar bütünü olmaktan çıkarak bir insan aktivitesi olarak karşımıza çıkmış olur.

Matematik tarihinin matematik eğitiminde kullanılmasına yönelik çalışmalar oldukça eskilere dayanmaktadır. Yeni bir yöntem yada çalışma alanı olarak 1960 larda düşünüldüğünde bile henüz duyulmamış bir kavram yada alan değildir (Fried, 2001).

Ülkemizde de matematik tarihinin matematik eğitiminde kullanılmasına yönelik araştırma ve çalışmalar mevcuttur. Alpaslan (2011) yüksek lisans tez çalışmasında ilköğretim matematik öğretmen adaylarının matematik tarihi bilgileri ve matematik tarihinin matematik eğitiminde kullanılmasına yönelik tutum ve inanışlarını incelemiştir. Matematik tarihinin matematik eğitiminde kullanılmasına yönelik tutum ve inançlarda, ilköğretim matematik programı eğitim sürecinde geçirilen süre arttıkça olumlu yönde artış gözlenmiştir (Alpaslan, 2011). Yenilmez (2011), çalışmasında matematik öğretmen adaylarının matematik tarihi dersine ilişkin düşüncelerini araştırmıştır.

“Matematik öğretmeni adaylarının matematik tarihi dersine ilişkin düşünceleri” başlıklı çalışmasında Yenilmez (2011), “Bir ilköğretim matematik öğretmeni adayı olarak Matematik Tarihi dersini almış olmak size ne kazandırdı?” sorusunu sormuş ve “Bir matematikçi olarak matematik konularının tarihini ve gelişimini bilmek çok önemlidir. Matematiğin gelişim aşamalarını adım adım anlama imkanımız oldu.”, “Matematik tarihini öğrenmek, matematiğe olan ilgimi artırdı.”, “Bilim adamlarının bizlerden çok farklı olmadıkları ve her şeyin çalışarak elde edilebileceğini gördüm. En önemlisi de bir matematikçinin içinde merak ve içgüdü olmalı.” gibi cevaplar alınmıştır. Bunun yanında “Dersin seçmeli olması daha iyi olurdu.”, “Buluşlar, keşifler ilginçti ancak dersin sözel oluşu biraz sıkıcı.” gibi cevaplar da gelmiştir. Ancak çalışma incelendiğinde öğretmen adaylarının matematik tarihi dersine karşı çoğunlukla olumlu tutum gösterdikleri anlaşılır (Yenilmez, 2011).

Ancak Fried (2001) e göre matematik tarihini matematik eğitimiyle bütünleştirmek sanıldığı kadar kolay ve sorunsuz bir süreç değildir. Müfredatını genişletmek istemeyen öğretmenler, mühendislik ve bilimsel çalışmalar için daha ön planda olan uygulamalı matematiği ön plana çıkarma zorunluluğu hissetme ve zaman yetersizliği sadece pratikte karşılaşılabilecek problemler olmakla birlikte, matematik tarihi ile matematik eğitimini bütünleştirmenin teorik anlamda da yaşattığı bir ikilem vardır (Fried, 2001). Ancak Fried bu makalesinde bahsettiği bu problemleri matematik tarihinin matematik eğitiminde kullanılmasının önüne set çekmek için yazmadığını belirtmiştir. Fakat matematik tarihini matematik eğitime entegre etmek isteyenlerin dikkatini bu sorunlara çekmeyi amaçlamıştır (Fried, 2001).

İlköğretim matematik kitaplarında matematik tarihindeki önemli kişilere ait kısa bilgilere ve eski matematikçilere ait portre ve fotoğraflara yer verilmektedir. Yine bazı konuların öğretiminde matematik tarihi ile ilişkili keşfetmeye yönelik etkinlikler kullanılmaktadır. Matematik derslerinde matematik tarihinden yararlanmak öğrenci motivasyonunu olumlu yönde etkileyebilir. Örneğin Pisagor Bağıntısı öğretilirken Pisagor' a ait bir kaç ilginç bilgi yada o dönemden biraz bahsetmek öğrencilerin ilgisini çekebilir. Bu bağlamda program, matematik derslerinde matematik tarihini kullanmayı tavsiye etmektedir (MEB, 2013) .

Matematik tarihi ortaokul matematik öğretim programlarında yer alabildiği gibi (MEB-2013), üniversite dersleri arasında 2005 ten itibaren genel kültür dersi olarak yer almaya başlamıştır (Yenilmez, 2011). Yine matematik tarihinin kullanımına matematik eğitimi araştırmalarında da rastlanmaktadır. ‘ Sonsuzluk kavramına ilişkin tarihi problemler ve paradokslar: Apos analizleri 1-2’ başlıklı çalışmalarında Dubinsky, Weller, McDonald ve Brown (2005), Aristo (M.Ö 384-322) nun ikilemi, Zenon Paradoksu, Bolzano (1741-1848) nun sonsuzluk algısı ve eklenebilecek pek çok tarihi içerikten, problem, kavram yada kişiden yararlanmışlardır. Bu da matematik tarihinin matematik eğitiminde üst düzeylerde de, genelleyecek olursak her düzeyde karşımıza çıktığına yönelik bir örnektir.

Bu çalışmanın da amacı literatürde karşımıza çıkan matematik tarihi ve matematik eğitimi çalışmalarının doğrultusunda, ilköğretim matematik öğretmen adaylarının matematik tarihinin matematik eğitiminde kullanılmasına yönelik inanç ve tutumlarını; cinsiyet, sınıf düzeyi, mezun olunan lise türü, daha önce matematik tarihinden bahsedilme, matematiksel yayınları takip sıklığı değişkenleri ile incelemektir.

1.1 Araştırma Problemi:

İlköğretim matematik öğretmen adaylarının matematik tarihinin matematik eğitiminde kullanılmasına yönelik tutum ve inanışları bazı değişkenlere göre değişmekte midir?

1.2 Alt problemler :

- 1) Matematik öğretmen adaylarının matematik tarihinin matematik eğitiminde kullanılmasına yönelik tutum ve inanışları ne düzeydedir?
- 2) Matematik öğretmen adaylarının matematik eğitiminde matematik tarihinin kullanılmasına yönelik tutum ve inançlar ortalama puanları cinsiyete göre farklılık göstermekte midir?
- 3) Matematik öğretmen adaylarının, matematik eğitiminde matematik tarihinin kullanılmasına yönelik tutum ve inançlar ortalama puanları, öğretmen adaylarının mezun oldukları lise türüne göre farklılık göstermekte midir?
- 4) Matematik öğretmen adaylarının, matematik eğitiminde matematik tarihinin kullanılmasına yönelik tutum ve inançlar ortalama puanları sınıf düzeylerine göre farklılık göstermekte midir?
- 5) Matematik öğretmen adaylarının, matematik eğitiminde matematik tarihinin kullanılmasına yönelik tutum ve inançları ile matematik tarihi içerikli yayınları takip etme sıklığı arasında ne tür bir ilişki vardır?

YÖNTEM

Bu çalışmada ilköğretim matematik öğretmen adaylarının matematik tarihinin matematik eğitiminde kullanılmasına yönelik tutum ve inançları incelenmeye çalışılmış ve betimsel tarama modeli kullanılmıştır.

2.1 Evren ve Örneklem

Bu çalışmanın evrenini, ilköğretim Matematik Öğretmenliğinde okuyan öğrenciler oluşturmaktadır. Örneklemi ise bu üniversitenin belirtilen anabilim dallarında iki, üç ve dördüncü sınıflarında öğrenim gören toplam 208 öğretmen adayı oluşturmuştur. Araştırmada öğretmen adaylarının matematik tarihinin matematik eğitiminde kullanılmasına yönelik tutum ve inançları, mezun oldukları lise türü, sınıf düzeyleri ve cinsiyetlerine göre karşılaştırılmıştır. Ayrıca matematik öğretmen adaylarının matematik tarihi içerikli yayınları takip etme sıklığı ile matematik tarihinin matematik eğitiminde kullanılmasına yönelik tutum ve inanışları arasındaki ilişki incelenmiştir. Bu bağlamda örnekleme ait sınıf, cinsiyet, okul türü, matematik tarihinden daha önce bahsedilmiş olması ve yayın takip sıklığı değişkenleri hakkındaki bilgiler Tablo 1’de sunulmuştur.

Tablo 1’ deki verilere göre örneklem cinsiyet değişkenine göre incelendiğinde kızların sayısının erkeklerin sayısından oldukça yüksek olduğu görülür. Sınıf değişkeni ele alındığında çoğunluğun üçüncü sınıfta olduğu anlaşılmaktadır. Mezun olunan lise türleri değişkeni incelendiğinde ise büyük çoğunluğu anadolu lisesi ve anadolu öğretmen lisesi mezunu öğretmen adayları oluşturmaktadır. Matematik tarihi içerikli yayın takibi sıklığına ise öğretmen adaylarının çoğunluğu bazen cevabını vermiştir.

Tablo 9: Öğretmen adaylarının tanımlayıcı değişkenlere göre dağılımı

Değişkenler	Özellik	N	%
Cinsiyet	Erkek	54	26,47
	Kız	154	73,53
Sınıf	2 inci	45	21,6
	3 üncü	90	43,3
	4 üncü	73	35,1
Okul Türü	Anadolu Öğrt. Lisesi	97	46,6
	Anadolu Lisesi	91	43,8
	Genel Lise	17	8,2
	Diğer	3	1,4
Mat. Tarihinden Bahsedilmiş Olma	Bahsedilmedi	110	52,9
	Bahsedildi	98	47,1
Yayın Takip Sıklığı	Hiç Bir Zaman	62	29,8
	Bazen	135	64,9
	Çoğunlukla	9	4,3
	Daima	2	1

2.2 Veri Toplama Aracı

Bu çalışmada veri toplama aracı olarak Alpaslan (2011) tarafından geliştirilen “Matematik Tarihinin Matematik Eğitiminde Kullanılmasına yönelik Tutum ve İnanışlar Anketi” kullanılmıştır. Ölçek, 5 li likert tipi olup ‘1’ ‘kesinlikle katılmıyorum’ ‘5’ ‘kesinlikle katılıyorum’ olacak şekilde 1 den 5 e doğru puanlanmıştır. Ölçek 35 maddeden oluşmaktadır. 35 maddenin 13 ü olumsuz maddeler olup bu maddeler değerlendirilirken puanlar dönüştürülmüştür. Bu bağlamda ölçekten alınabilecek en yüksek puan 175 iken en düşük puan da 35 tir. Alpaslan (2011) çalışmasında Cronbach alfa iç tutarlılık güvenilirlik katsayısını .93 olarak hesaplamıştır. Bu çalışmadaki örnekleme dayanarak ölçek için Cronbach alfa iç tutarlılık güvenilirlik katsayısı .94 olarak bulunmuştur.

2.3 Veri Analizi

Çalışmanın verileri incelenmeden önce eksik verili ölçekler, çalışmadan çıkartılmıştır. Cinsiyet değişkeni ile matematik tarihinin matematik eğitiminde kullanılmasına yönelik tutum ve inançlar arasındaki ilişki incelenirken bağımsız gruplar için t-testi kullanılmıştır. Öğretmen adaylarının tutum ve inançlarındaki, mezun olunan lise türü ve sınıf düzeyleri arasındaki farklılığı ortaya koymak için tek yönlü varyans analizi (ANOVA) kullanılmıştır. Yine matematik yayın takip sıklığı ile tutum ve inançlar arasındaki ilişkiyi incelemek için basit korelasyon Pearson Korelasyon katsayısı kullanılmıştır.

BULGULAR

Bu bölümde Dokuz Eylül Üniversitesi İlköğretim Matematik öğretmenliği anabilim dalında öğrenim görmekte olan öğretmen adaylarına uygulanan matematik tarihinin matematik eğitiminde kullanılmasına yönelik tutum ve inanışlar anketinden elde edilen bilgilerin istatistiksel analizi yapılmış ve sunulmuştur.

Araştırmanın birinci alt probleminde “Matematik öğretmen adaylarının matematik tarihinin matematik eğitiminde kullanılmasına yönelik tutum ve inanışları ne düzeydedir?” sorusuna yanıt aranmıştır. Matematik öğretmen adaylarının matematik tarihinin matematik eğitiminde kullanılmasına yönelik tutum ve inanışları ortalama puanlarına ilişkin bulgular Tablo 2’de sunulmaktadır.

Tablo 2: Öğretmen adaylarının tutum ve inanış düzeylerine ait bulgular

N	Min.	Max.	\bar{X}	ss	Skewness	Kurtosis
---	------	------	-----------	----	----------	----------

					Stat.	SE	Stat	SE	
Tutum ve İnanışlar Anketi Sonuçları	208	1.77	4.89	3.70	.52	-.81	.17	1.88	.34

Tablo 2’ deki sonuçlarda matematik öğretmen adaylarının tutum ve inanç puan ortalamaları .52 standart sapma değeri ile 5 üzerinden 3.70 olarak bulunmuştur. Çarpıklık katsayısı -.81, basıklık katsayısı ise 1.88 olarak bulunmuştur. Bu değerlere göre ortalama puanların normal dağılım gösterdiği söylenebilir.

Araştırmanın ikinci alt probleminde “Matematik öğretmen adaylarının matematik eğitiminde matematik tarihinin kullanılmasına yönelik tutum ve inançlar ortalama puanları cinsiyete göre farklılık göstermekte midir?” sorusuna yanıt aranmıştır. Cinsiyete göre tutum ve inanç puanlarında farklılık olup olmadığına bakmak üzere bağımsız örneklem için t testi kullanılmıştır. Sonuçlar Tablo 3’ te gösterilmektedir.

Tablo 3: Öğretmen adaylarının cinsiyetlerine göre tutum ve inanç ortalama puanlarına ilişkin t testi sonucu

Cinsiyet	N	\bar{X}	ss	t	p
Erkek	54	3.57	.67	-1.87	0.65
Kız	154	3.76	.46		

Tablo 3’ te görüldüğü üzere öğretmen adaylarının cinsiyete göre tutum ve inanç ortalama puanlarında kızların tutum ve inançları puan ortalaması .19 puan daha yüksek bulunmuştur. Ancak bu fark istatistiksel olarak anlamlı bulunmamaktadır ($t = -1.87$; $p > 0,05$).

Araştırmanın üçüncü alt probleminde “Matematik öğretmen adaylarının, matematik eğitiminde matematik tarihinin kullanılmasına yönelik tutum ve inançlar ortalama puanları, öğretmen adaylarının mezun oldukları lise türüne göre farklılık göstermekte midir?” sorusuna cevap aranmış ve istatistiksel inceleme için tek yönlü varyans analizi yapılmıştır. Anova analizinde ilk olarak grupların varyanslarının eşitliği levne testi ile test edilmiştir. Levene testi 1.08 sonucuna göre $p = .36$ ($p > 0,05$) olduğundan grupların varyansları eşittir. Anova testine ilişkin bulgular Tablo 4’da verilmektedir.

Tablo 4: Öğretmen adaylarının mezun oldukları lise türüne göre tutum ve inançları ortalama puanlarına ilişkin anova testi sonucu

Varyansın Kaynağı	Kareler Toplamı	sd	Kareler Ortalaması	F	P
Gruplararası	.495	3	.165	.592	.621
Gruplarıçi	56.839	204	.279		
Toplam	57.334	7			

Tablo 4’ ten görüldüğü üzere öğretmen adaylarının mezun oldukları lise türlerine göre matematik tarihinin matematik eğitiminde kullanılmasına yönelik tutum ve inançları ortalama puanları arasında bir fark yoktur ($F = .592$; $p > .5$).

Araştırmanın dördüncü alt probleminde “Matematik öğretmen adaylarının, matematik eğitiminde matematik tarihinin kullanılmasına yönelik tutum ve inançlar ortalama puanları sınıf düzeylerine göre farklılık göstermekte midir?” sorusuna cevap aranmıştır. Matematik öğretmen adaylarının öğrenim gördükleri sınıfa göre tutum ve inançlar ortalama puanları arasındaki farkı belirleyebilmek için tek yönlü varyans analizi yapılmıştır. Anova analizinde ilk olarak grupların varyanslarının eşitliği levne testi ile test edilmiştir. Levene testi .687 sonucuna göre $p = .504$ ($p > 0,05$) olduğundan grupların varyansları eşittir. Anova testine ilişkin bulgular Tablo 5’ te verilmektedir.

Tablo 5’te görüldüğü üzere öğretmen adaylarının öğrenim gördükleri sınıfa göre matematik tarihinin matematik eğitiminde kullanılmasına yönelik tutum ve inançlar ortalama puanları arasında anlamlı bir farka rastlanmıştır ($F = 3.173$; $p < .05$). Bu farkın nereden kaynaklandığını tespit etmek için LSD çoklu karşılaştırma testi kullanılmış, 2 ve 4 üncü sınıfların ortalama puanları arasında 4 üncü sınıflar lehine anlamlı bir fark olduğu görülmüştür.

Tablo 5: Öğretmen Adaylarının Öğrenim Gördükleri Sınıfa Göre Tutum Ve İnançları Ortalama Puanlarına İlişkin Anova Testi Sonucu

Varyansın Kaynağı	Kareler Toplamı	sd	Kareler Ortalaması	F	P	Anlamlı Fark
Gruplararası	1.721	2	.861	3.173	.044*	2-4 sınıflar
Gruplariçi	55.612	205	.271			
Toplam	57.334	207				

Araştırmanın beşinci alt probleminde ise ‘‘Matematik öğretmen adaylarının, matematik eğitiminde matematik tarihinin kullanılmasına yönelik tutum ve inançları ile matematik tarihi içerikli yayınları takip etme sıklığı arasında ne tür bir ilişki vardır?’’ sorusuna cevap aranmıştır. Matematik öğretmen adaylarının matematik tarihi içerikli yayın takip etme sıklığı ile tutum ve inanç puanları arasındaki ilişki düzeyi ve yönünü belirlemek için basit korelasyon Pearson Korelasyon katsayısı kullanılmıştır. Matematik tarihi içerikli yayın takip etme sıklığı ve tutum ve inanç ortalama puanları arasındaki ilişkiye ait bulgular Tablo 6’ da gösterilmiştir.

Tablo 6: Öğretmen Adaylarının Matematik Tarihi İçerikli Yayın Takip Etme Sıklığı İle Tutum Ve İnanç Ortalama Puanları Arasındaki Korelasyon Testine İlişkin Sonuçlar

Değişkenler	N	\bar{X}	ss	r	p
Yayın takip sıklığı	208	1.76	.57	.274	.00*
Tutum ve inanç ortalama puanları	208	3.70	.53		

Tablo 6 incelendiğinde matematik öğretmen adaylarının matematik tarihi içerikli yayınları takip etme sıklığı ile matematik tarihinin matematik eğitiminde kullanılmasına yönelik tutum ve inançlar ortalama puanları arasında pozitif yönde düşük düzeyde bir ilişki var olduğu çıkarılabilir ($r = .274$; $p < .01$). Determinasyon katsayısı ($r^2 = .08$) dikkate alındığında toplam varyansın %8’ nin matematik yayın takip sıklığından kaynaklandığı söylenebilir (Büyüköztürk, 2013).

SONUÇ

Bu araştırma matematik öğretmen adaylarının matematik tarihinin matematik eğitiminde kullanılmasına yönelik tutum ve inanç düzeylerini belirlemek ve tutum ve inanç düzeylerinin cinsiyet, sınıf, mezun olunan lise türü değişkenlerine göre farklılaşmasını incelemek amacıyla yapılmıştır. Ayrıca öğretmen adaylarının matematik tarihi içerikli yayınları takip sıklığı ile matematik tarihinin matematik eğitiminde kullanılmasına yönelik tutum ve inanç ortalama puanları arasındaki ilişki incelenmiş ve düşük düzeyde pozitif bir ilişkiye rastlanmıştır. Öğretmen adaylarının tutum ve inanç ortalama puanlarının düzeyine ilişkin istatistiksel incelemeler sonucunda öğretmen adaylarının ortalama puanlarının yüksek düzeyde olduğu gözlemlenmiştir. Buna göre öğretmen adaylarının matematik tarihinin matematik eğitiminde kullanılmasına yönelik tutum ve inançlarının olumlu olduğu söylenebilir. Bu sonuçlar Alpaslan (2011) ve Gürsoy (2010) çalışmalarını ile uyum göstermektedir. Cinsiyet değişkenine göre inanç ve tutum ortalama puanları arasındaki fark incelendiğinde; öğretmen adaylarının tutum ve inanç ortalama puanlarının cinsiyete göre anlamlı bir farklılık göstermediği ortaya çıkmıştır. Bu sonuç, Alpaslan (2011) ait çalışmada kızların tutum ve inanç ortalama puanlarının daha yüksek olduğu bulgusuyla çelişki içindedir. Bu çelişki örneklem farklılığına bağlanabilir. Öğretmen adaylarının tutum ve inanç ortalama puanları sınıf değişkenine göre incelendiğinde ikinci ve dördüncü sınıftaki öğretmen adaylarının ortalama puanları arasında farklılığa rastlanmıştır. Dördüncü sınıf öğretmen adaylarının tutum ve inanç ortalama puanlarının daha yüksek olduğu tespit edilmiştir. Bu bulgular Alpaslan (2011) ait çalışmadaki bulgularla örtüşmektedir. Tutum ve inanç ortalama puanlarındaki artış sebebinin üniversite ders programlarında yer alan üçüncü sınıftaki Bilim Tarihi ve dördüncü sınıftaki Matematik Tarihi derslerinden kaynaklandığı tahmin edilmektedir (Alpaslan, 2011). Yine benzer sebeplerle matematik tarihinden bahsedilmiş öğretmen aday sayısında sınıf düzeylerindeki ilerlemeye göre artış görülmektedir. Öğretmen adaylarının mezun oldukları lise türüne göre tutum ve inançlar ortalama puanlarında anlamlı bir farklılığa rastlanmamıştır.

ÖNERİLER

Öğretmen adaylarının matematik tarihinin matematik eğitiminde kullanılmasına yönelik tutum ve inançları başka değişkenler kullanılarak da incelenebilir. Matematik tarihine ve matematik eğitiminde kullanılmasına

yönelik olumsuz tutum geliştiren adayların bu yönde tutum geliştirmelerinin altında yatan nedenler araştırılabilir. Bunun yanı sıra veri toplama teknikleri görüşme formları kullanılarak zenginleştirilebilir ve sonuçlar desteklenebilir.

Matematik tarihini matematik eğitiminde kullanabilmek için matematik tarihi bilgisine sahip olmanın gerekliliği bilinmektedir. Bu konuda Alpaslan (2011)' in öğretmen adaylarının tutum ve inanç puanları ile matematik tarihi bilgileri arasındaki ilişkiyi incelediği çalışması mevcuttur. Bu çerçevede üniversite ders programlarında bu konuya ilişkin derslerin yer alıp almadığına ve dersin işleniş yöntemlerine yönelik araştırmalar ve bu yöntemlerin sonucunda gelişecek tutumlara yönelik araştırmalar planlanabilir.

Matematik tarihini matematik derslerinde kullanmak üzere etkinlikler tasarlanabilir ve bu etkinliklerin uygulanmasının sonuçları incelenebilir. Bu anlamda matematik tarihinin derslerde kullanılabilmesine yönelik materyal sayısında da artış sağlanmış olur.

KAYNAKLAR

Alpaslan, M. (2011). Prospective Elementary Mathematics Teachers' Knowledge of History of Mathematics and Their Attitudes and Beliefs Towards The Use of History of Mathematics In Mathematics Education (Yüksek Lisans Tezi). <https://tez.yok.gov.tr/UlusalTezMerkezi/> (25 Kasım 2013).

Bidwell, J.K. (1993). Humanize your classroom with the history of mathematics. Mathematics Teacher, National Council of Mathematics <http://www.jstor.org/stable/27968440> (23 Kasım 2013)

Duinsky, Weller, McDonald & Brown (2005). Some Historical Issues and Paradoxes Regarding the Concept of Infinity: An Apos-Based Analysis: Part 1-2. *Educational Studies in Mathematics* 58: 335-359

Fauvel, Keynes ve van Maanen (1997- 2000). The Role of the History of Mathematics in the Teaching and the Learning of Mathematics Discussion Document for an ICMI Study. <http://www.emis.ams.org/journals/ZDM/zdm974i1> (23 Kasım 2013).

Fried, M. N. (2001). Can Mathematics Education and History of Mathematics Coexist? *Science and Education* 10: 391-408, 2001. *Kluwer Academic Publishers*. Printed in the Netherlands

Furinghetti, F . (2004). History and Mathematics Education: A look around the World with Particular Reference to Italy. *Mediterranean Journal for Research in Mathematics Education* Vol.3, 1-2, 1-19.

Gürsoy, K. (2010). İlköğretim Matematik Öğretmen Adaylarının Matematik Tarihinin Matematik Öğretiminde Kullanılmasına İlişkin İnanç ve Tutumlarının İncelenmesi (Yüksek Lisans Tezi). <https://tez.yok.gov.tr/UlusalTezMerkezi/> (15 Ocak 2013).

Milli Eğitim Bakanlığı (MEB). (2013). Ortaokul Matematik Dersi (5, 6, 7 ve 8. Sınıflar) Öğretim Programı. [PDF dokümanı].

Öztürk, Ş. (2013). *Sosyal Bilimler için Veri Analizi El Kitabı* (18. baskı). Ankara: Pegem Akademi.

Sertöz, S. (2002). *Matematiğin aydınlık dünyası*. TÜBİTAK popüler bilim kitapları 36, Ankara: Semih ofset.

Yenilmez, K. (2011). Matematik Öğretmeni Adaylarının Matematik Tarihi Dersine İlişkin Düşünceleri. *Pamukkale Üniversitesi Eğitim Fakültesi Dergisi*, Sayı 30 (Temmuz 2011/II), ss. 79-90

MESLEK YÜKSEKOKULLARINDA ÖĞRENCİLERİN MATEMATİK BAŞARI SIRASI İLE GENEL BAŞARI SIRALAMASININ İNCELENMESİ

THE EXAMINATION OF THE MATHEMATICS RANKINGS WITH THE OVERALL SUCCESS RANKINGS OF THE STUDENTS IN VOCATIONAL SCHOOLS

Şeyda İLDAN
Selçuk Üniversitesi
seydaildan@selcuk.edu.tr

ÖZET: Tüm dünyada ve ülkemizde yetişmiş ara eleman gücüne ihtiyaç artmaktadır. Ara eleman gücünü ve yetişmiş kalifiye eleman açığını karşılayacak en iyi kurumlar meslek yüksekokullarıdır.

İleri teknolojinin kullanıldığı sanayide, görev yapan kalifiye elemanların fiziki becerilerinin yerini zihinsel becerileri almakta, iş gücünde yeterliliğin çeşitlendiği bilgi-işlem kullanımının vazgeçilmez nitelikler arasına girdiği görülmektedir. Bu nedenle de meslek yüksekokulları kapsamındaki sosyal ve teknik alanlarda matematik dersinin önemi artmıştır. Meslek yüksekokullarındaki matematik derslerinin temel amacı, öğrencilere analitik düşünme ve doğru karar verebilme yeteneğini kazandırmanın yanı sıra matematiksel düşünme yoluyla zihinsel esnekliğe sahip olmalarını sağlamaktır.

Bu çalışmada yetmiş bilgisayar programcılığı öğrencisinin matematik dersi dönem sonu başarı sırası ile dönem sonu genel not ortalamasını sıralanmıştır ve toplanan verilere “ Spearman Brown Sıra Farkları Korelasyon Katsayısı” kullanılarak analiz edilmiştir.

Sonuçlara göre, öğrencileri matematik dersi başarı sırası ile genel not ortalaması başarı sırası arasında bir ilişki gözlenmiştir.

Buna göre, matematik dersinde başarılı öğrencilerin, genel olarak tüm derslerde de başarılı olduğu söylenebilmektedir.

Anahtar sözcükler: meslek yüksekokulları, matematik, Spearman Brown Sıra Farkları Korelasyon Katsayısı

ABSTRACT: Need for qualified intermediate staff has been increased in our country and all over the world. The best institutions to fulfill the need of qualified intermediate staff are vocational schools.

In industry which high technology is used in, the physical abilities of qualified staff are replaced with their mental abilities, and use of information technologies which vary the need in labor is now an indispensable qualification. Therefore, vocational schools whose aim is to make students acquire the ability of analytical thinking and giving the right decision and also to make the students have the ability of mental elasticity through mathematical thinking.

I've listed the success of the seventy vocational school students who are training on Computer Technologies by having the base of the semester grade about the level achievement of General Mathematics and final success status by GPA. I've applied " Spearman Brown Rank Correlation Test " for the data which had been collected by me.

According to the results obtained a compromise between the overall success of mathematics rankings and the success of the overall grade point average of all courses.

Accordingly, it has been considered that the students who have high increase at mathematical success have high increase success at the overall performance for all courses.

Key words: vocational schools, mathematic, Spearman Brown Rank Correlation Test.

GİRİŞ

(Turanlı, Türkler ve Keçeli, 2008) Matematik aslında evrensel ve soyut bir iletişim aracıdır. Tüm bilimlerin ortak dili matematiktir. Galileo “Bilim gözlerimiz önünde açık duran ‘evren’ dediğimiz o görkemli kitapta yazılıdır. Ancak yazdığı dili ve alfabesini öğrenmeden bu kitabı okuyamayız. Bu dil matematiktir, bu dil olmadan kitabın bir tek sözcüğünü anlamaya olanak yoktur” demiştir.

Günümüzde bu gerçek değişmedi, hatta ileri teknolojinin kullanıldığı sanayide görev yapan kalifiye elemanların fiziki becerisinin yerini zihinsel becerileri almakta, iş gücünde yeterliliğin çeşitlendiği bilgi-işlem kullanımının vazgeçilmez nitelikler arasına girdiği görülmektedir. Bu nedenle meslek yüksekokulları kapsamında programların birçoğunda matematik dersi zorunlu hale gelmiştir. Burada matematik dersinin temel amacı; öğrencilere analitik düşünme ve doğru karar verebilme yeteneğini kazandırmanın yanı sıra matematiksel düşünme yoluyla zihinsel esnekliğe sahip olmalarını sağlamaktır. Ancak meslek yüksekokulu öğrencilerinin genel olarak matematik ve matematik tabanlı dersleri anlamakta, kavramakta ve işlem yapmakta yetersiz oldukları bilinmektedir.

(Kaya, Özdemir, Utkun, 2013) Bu kadar önemli olan ve insanların geleceğine yön veren bu ders, öğrencilerin çoğu tarafından sevilmemekte hatta sıkıcı ve anlaşılmaz bulunmaktadır. Bu şekilde anlaşılmasının en önemli sebeplerinin başında da öğrencilerin dersle ilgili duymuş olduğu kaygılar gelmektedir. Dersin anlaşılmasının diğer derslere göre daha zor olması, öğrencilerin dersi anlamak ve öğrenmekten ziyade dersi ezberlemek ve geçmek için çalışmaları başarısızlığı etkileyen faktörlerdendir. Bu tutumun gelişmesinde ilköğretimden başlanan yanlış öğrenme metotları ve öğrenciye dersin hayatında ne kadar önemli bir yer tutacağını ve nasıl kullanılacağını yeterince anlatılmamasından kaynaklandığı görülmektedir.

Matematik eğitiminde başarıyı etkileyen faktörler üzerine birçok araştırma yapılmıştır. Reusser (2000) tarafından yapılan çalışmada; genel olarak başarının öğrenme, stratejiler ve inançlarla ilişkili olduğu burada en büyük faktörün aile olduğu vurgulanmıştır. Ayrıca başarısızlığı etkileyen faktörlerden bir diğeri de bizzat öğrencilerin iyi çalışma tutum ve alışkanlıklarına sahip olmamalarıdır. Uysal (2007) tarafından yapılan çalışmada meslek yüksekokullarına sınavsız yerleşen öğrencilerin matematik başarısının daha düşük olduğu ve cinsiyetin başarıda bir etkisinin olmadığı tespit edilmiştir.

Bu çalışmada ise matematik eğitimindeki başarıyı etkileyen faktörler ve matematiğin insanlara kazandırdığı zihinsel esneklik ve analitik düşünebilme yeteneğinin kazandırdıklarından dolayı yetmiş meslek yüksekokulu öğrencisinin 1. Yarıyıl sonundaki matematik dersi ile genel olarak dönem sonu ders notlarının ortalamasının ilintili olduğu gözlenmiştir.

ARAŞTIRMANIN AMACI VE MODELİ

Araştırma meslek yüksekokullarında eğitim gören öğrencilerin matematik tabanlı derslerdeki başarısıyla, diğer derslerdeki genel başarısını karşılaştırma amacıyla yapılmıştır.

Çalışma Grubu

Bu çalışma zaman ve maliyet kısıtından dolayı, Konya ili Akören ilçesinde yer alan meslek yüksekokulunda gerçekleştirilmiştir.

Veri Toplama Aracı

Araştırmada kullanılan veri toplama yöntemi, öğrencilerin 1. dönem aldıkları vize-final sonucu matematik dersi puanları ile 1. dönem tüm derslerin genel ortalamasıdır.

YÖNTEM

Elde edilen veriler Spearman Brown Sıra Farkları Korelasyon Katsayısı (SPEARMAN RHO, rs) yöntemi kullanılarak analiz edilmiştir.

BULGULAR

Araştırmaya Katılanlar Hakkında Genel Bilgiler

Araştırmaya katılan meslek yüksekokulu öğrencilerinin Tablo 1’de görüldüğü gibi %30’u kız ve %70’i erkek öğrenciden oluşmaktadır.

Araştırmaya katılan meslek yüksekokulu öğrencilerinin Tablo 2’de görüldüğü gibi %97.14’ü meslek lisesi, %2,8’ i düz lise mezunudur.

Tablo 1. Meslek yüksekokulu Öğrencilerinin Genel Özellikleri

Değişkenler		Frekans	Yüzde
Cinsiyet	K	21	30
	E	49	70
TOPLAM		70	100

Tablo 2. Mezun Olunan Lise Türü

Değişkenler		Frekans	Yüzde
	Düz lise	2	2.86
	Meslek lisesi	68	97.14
TOPLAM		70	100

Meslek Yüksekokulu Öğrencilerinin Matematik Dersi Başarı Sırası İle Dönem Sonu Genel Not Ortalaması Başarı Sırası

Öğrencilerin vize-final sonucu aldıkları puanlar sonucu matematik dersindeki aldıkları puanlar yüksekten düşüğe doğru sıraya dizilir, daha sonra en yüksek puana 1 verilerek sıra değerleri elde edilir. Daha sonra öğrencilerin 1. Dönem sonunda vize-final sonucu aldıkları notlara göre bütün dersleri için elde edilen genel not ortalamaları baz alınarak yüksekten düşüğe sıralanır, daha sonra en yüksek puana 1 verilerek sıra değerleri elde edilir. Tablo 3 hazırlanır.

Tablo 3. Meslek Yüksekokulu Öğrencilerinin Matematik Dersi Başarı Sırası İle Dönem Sonu Genel Not Ortalaması Başarı Sırası Ve Sıra Farkları

Matematik başarı sırası	Dönem sonu başarı sırası	Fark(d)	d ²
2	1	1	1
3	2	1	1
5	3	2	4
1,5	4	-2,5	6,25
1,5	5	-3,5	12,25
4	6	-2	4
6	7	-1	1
5	8	-3	9
9	9	0	0
5	10	-5	25
8	11	-3	9
12	12	0	0
23	13	10	100
22	14	8	64
15	15	0	0
14	16	-2	4
7	17	-10	100
8	18	-10	100
5	19	-14	196
10	20	-10	100

17	21	-4	16
11	22	-11	121
17	23	-6	36
25	24	1	1
12	25	-13	169
25	26	-1	1
21	27	-6	36
19	28	-9	81
16	29	-13	169
25	30	-5	25
16	31	-15	225
13	32	-19	361
26	33	-7	49
20	34	-14	196
20	35	-15	225
24	36	-12	144
18	37	-19	361
32	38	-6	36
30	39,5	-9,5	90,25
25	39,5	-14,5	210,25
34	40	-6	36
33	41	-8	64
28	42	-14	196
27	43	-16	256
32	44	-12	144
31	45	-14	196
34	46	-12	144
35	47	-12	144
40	48	-8	64
35	49	-14	196
38	50	-12	144
31	51	-20	400
36	52	-16	256
28	53	-15	225
37	54	-17	289
36	55	-9	81
40	56	-16	256
37	57	-20	400
39	58	-19	361
43	59	-16	256
41	60	-19	361
42	61	-19	361
40	62	-22	484
44	63	-19	361
45	64	-19	361
42	65	-23	529
46	66	-20	400
47	67	-20	400
48	68	-20	400
47	69	-22	484
n=70	n=70	$\Sigma d = -741$	$\Sigma d^2 = 12218$

SONUÇ

Analizde $r_s=0,787$ bulunmuştur. Bu bulgu, 70 öğrencinin matematik dersi başarı sırası ile genel not ortalaması başarı sırası arasında bir uyuşmanın olduğunu gösterir. Buna göre, matematik dersinde başarılı olan öğrencilerin genel olarak diğer derslerde de başarılı olduğu söylenebilir.

ÖNERİLER

Birçok bilimin çıkış noktası olan matematik çağdaş dünyamızda da geleceğe yön vermek isteyenlerin başarılı olmasının şart olduğu bir bilimdir. Bu kadar önemli bir bilim olmasına ve okul hayatındaki genel başarıyı doğrudan etkilemesine rağmen öğrencilerin büyük bir kısmı dersi anlamakta ve uygulamakta zorluk çekmektedirler. Bugüne kadar yapılan birçok çalışmada öğrencilerin matematik dersinde zorlanmasının birçok nedeni olduğunu özellikle dersin anlaşılmasında eksikliğin olduğunu ve çalışma metotlarındaki yanlışların öğrencileri başarısızlığa ittiğini göstermiştir.

Çoğunlukla meslek liselerinden sınavsız geçişle gelen meslek yüksekokullarındaki öğrencilere fen ve matematik dersleri yeterince öğretilmemektedir. Bunun sonucunda da bu öğrenciler genel olarak matematik ve matematik tabanlı dersleri anlamakta, kavramakta ve işlem yapmakta yetersiz kalmaktadır. Hatta matematiğin insana kazandırdığı zihinsel esnekliğe yeterince sahip olunamamasından da dolayı matematik başarı sırası ile genel başarı sırası arasında uyumlu bir ilişki vardır.

Bu nedenlerden dolayı meslek yüksekokullarında matematik eğitimini her bölüm yeterince almalıdır. Matematik eğitimi uygulanmasında öğrencinin istek ve ilgisi artırılmalı. Öğrencilere matematiğin önemi kavratılmalı ve mesleki olarak da matematiği kullanabileceği alanlarla ilgili uygulamalar yapılmalıdır.

KAYNAKLAR

- Kaya, Y., & Özdemir, S., & Utkun, E., (2013). Factors affecting the success in mathematics of vocational school students: in terms of students opinions. *Electronic Journal of Vocational Colleges*, 62, 68.
- Uysal, F., (2007). A comparison of the success of vocational school students in basic mathematics based upon their method of placement in university. *Educational Sciences: Theory Practice*, 7(2), 991,-997.
- Reusser, K., (2000). Success and failure in school mathematics: effects of instruction and school environment. *European Child & Adolescent Psychiatry*, 9(2), 18-25.
- Turanlı, N., & Karakaş Türker, N., & Keçeli, V., (2008). Matematik alan derslerine yönelik tutum ölçeği geliştirilmesi, *Hacettepe Üniversitesi Eğitim Fakültesi Dergisi*, 34, 254-262.
- Büyüköztürk, Ş., & Çokluk, Ö., & Köklü, N., (2011). Sosyal Bilimler için İstatistik, *Pegem Yayıncılık, Ankara*.
- Polat, V., & Dönmez D., Meslek Yüksekokullarında kaliteli eğitimin koşulları, *Kişisel Gelişim Merkezi*.
- Sarı, M., (2014). Meslek Yüksekokullarında okuyan öğrencilerin sayısal derslerdeki başarısını olumsuz yönde etkileyen nedenlerin öğrenci görüşlerinden yararlanarak incelenmesi. *Eğitim ve Öğretim Araştırmaları Dergisi*, 2146-9199.

MATHEMATICS ACTIVITIES OF PEOPLE AT DIFFERENT LEVEL

Yunus GÜDER
Ministry of Education
yunusguder2010@hotmail.com

ABSTRACT: The purpose of this study, the mathematical sciences in different age groups and different levels of education is to reveal how it is used by people. For this purpose literature on the history of mathematics has been examined in detail and compared with the use of today. Study participants consist of illiterate and not subject to any formal education 4 people, literate and formal education through a variety of 4 people, finally started school but do not have the skills to four operations a total of 12 people including four kindergarten students. In the study, case study method was used. Data were obtained through various interviews and observations. As a result of this study, it was determined that, four operations are often used in different ways, people have developed a method that suits them and any symbol or formula is not used in the calculations.

Key words: mathematics education, four operations skills, different calculations

ORTAOKUL 5.SINIF FEN BİLİMLERİ DERSİ ETKİNLİKLERİNİN LABORATUVAR KULLANIM TEKNİKLERİ VE KAZANIMLARA UYGUNLUĞU AÇISINDAN İNCELENMESİ

Cemil AYDOĞDU*

Halil İbrahim AKILLI**

ÖZET: Bu çalışmanın amacı, Ortaokul 5. Sınıf fen bilimleri ders kitabındaki etkinliklerin laboratuvar kullanım teknikleri ve Fen bilimleri kazanımlarına uygunluğu açısından incelenmesidir. Çalışmada, nitel araştırma yöntemlerinden doküman incelemesi tekniği kullanılmıştır. Ders kitabındaki etkinlikler laboratuvar kullanım teknikleri açısından ve kazanımlara uygunluk açısından incelenmiş; ulusal ve yerel basından laboratuvarlarda meydana gelen kazaların sonuçları ayrıca değerlendirilmiştir. Sonuçta bazı etkinliklerin kazanımları karşılamadığı ve laboratuvar kullanım teknikleri açısından uygulanmasının sakıncaları olduğu belirlenmiştir. Laboratuvardaki kazaların önlenmesi ve konuların daha iyi anlaşılabilmesi için kazanımlarda laboratuvar kullanım teknikleri ile ilgili bölümlerin de olması gerektiği ve öğretmenlerin yapılan etkinlikler sırasında kullanılan malzemelerin özellikleri hakkında daha fazla bilgi sahibi olmaları gerektiği düşünülmektedir.

Anahtar Kelimeler: Fen ve Teknoloji etkinlikleri, kazanım, laboratuvar kazaları, öğretmenlerin davranış tarzı

ABSTRACT: The purpose of this study , 5 Secondary Class activities in science textbooks and science laboratory techniques is to analyze the suitability of the gains . In this study, document analysis techniques of qualitative research methods were used. In the textbook activities and achievements in terms of the use of laboratory techniques examined in terms of compliance with the national and local press, the result of accidents that occur in the laboratory were also evaluated . The result does not meet some of the activities and achievements of the use of laboratory techniques in terms of implementation it was determined that the drawbacks . In the laboratory accident prevention and issues better understanding gains for the use of laboratory techniques related departments also should be teachers and the activities used during the properties of materials Learn more about owning the products need to be .

Keywords: Science and Technology activities, gain, laboratory accidents, teachers behaviour manners

1.GİRİŞ:

Bilimsel bilginin gittikçe arttığı, teknolojik gelişmelerin büyük bir hızla ilerlediği, fen ve teknolojinin etkilerinin yaşamımızın her alanında belirgin bir şekilde görüldüğü günümüz bilgi ve teknoloji çağında, toplumların geleceği açısından fen ve teknoloji eğitiminin anahtar bir rol oynadığı açıkça görülmektedir (Aydoğdu & Kesercioğlu, 2005). Bu amaçla, başta gelişmiş ülkeler olmak üzere bütün toplumlar sürekli bir şekilde fen ve teknoloji eğitimini yaygınlaştırmak ve kalitesini daha da arttırma uğraşı içerisindeyler. Fen bilimleri, kişinin yaşantısını etkilediği ölçüde önem ve değer taşır.

Çocuklar bu derste, doğadaki varlıkları ve olayları bilimsel yönden ele alıp; gözlemlene, inceleme ve anlama olanağı elde ederler. Fen ve Teknoloji okuryazarlığı; bireylerin araştırma-sorgulama, eleştirel düşünme, problem çözme ve karar verme becerileri geliştirmeleri, yaşam boyu öğrenen bireyler olmaları, çevreleri ve dünya hakkındaki merak duygusunu sürdürmeleri için gerekli olan fenle ilgili bilgi, beceri, tutum ve değerlerin bir bileşimidir(Tunç ve ark., 2010a).2004 öğretim programı ile öğrenci merkezli, dolayısıyla etkinlik merkezli, bilgi ve beceriyi dengeleyen öğrencinin kendi yaşantılarını ve bireysel farklılıklarını dikkate alarak çevreyle etkileşimine olanak sağlayan yeni bir anlayış yaşama geçirilmeye çalışılmaktadır (MEB, 2005a).

Ders kitapları okullarda yaygın olarak kullanılan ders araçlarındandır. Öğretimde, her zaman önemli bir yere sahip olan ders kitapları teknolojiye ilerlemelere rağmen kullanılma özellik ve önemini hala sürdürmektedir. Ders kitabı, belirli bir dersin öğretim programında öngörülen konuların işleniş için gereken bilgileri içeren bir araçtır (Akinoğlu, Şahin ve Gürdal, 2002). Ders kitapları eğitim programının temel unsurlarından birisidir. Eğitim programı ile öğrenci arasındaki en iyi temel iletişim kaynağıdır. Öğretimde öğretmenin gücünü daha iyi kullanmasına, vermek istediklerini daha sistematik vermesine; öğrencinin de öğretmenin anlattıklarını istediği zaman ve yerde istediği tempoda tekrar etmesine olanak sağlayan temel araçlardır (Aycan ve ark., 2002). Ders kitapları bilginin taşınabilir bir şeklidir ve öğrenciler, istedikleri yer ve zamanda arzu ettikleri düzeyde bilgi edinebilmektedirler (Koseoğlu ve diğerleri, 2003).Ders kitapları, eğitim amaçlarını gerçekleştirmek üzere öğrencinin öğrenmesine kaynaklık eden (Aycan ve diğerleri, 2002), öğretim programlarında yer alan konulara

ait bilgileri planlı ve düzenli bir biçimde inceleyip açıklayan, bilgi kaynağı olarak öğrenciyi dersin hedefleri doğrultusunda yönlendiren ve eğiten temel bir ortamdır (Unsal ve Gunes, 2003: 116).

Ders kitaplarıyla ilgili yapılmış pek çok çalışma bulunmaktadır. Yapılan çalışmalarda ders kitaplarının içerik, organizasyon, okunma düzeyi, resimler ve ders kitabının fiziksel görünümü gibi özelliklerinin daha ayrıntılı olarak incelendiği göze çarpmaktadır (Demirbaş, 2008; Balım ve ark., 2007; Maskan ve ark., 2007). Ancak ders kitaplarının sadece görünüş açısından incelenmesi kitapların yeterlilikleri anlamında bilgi vermekten oldukça uzaktır. İyi bir ders kitabında yanlış-eksik bilgiler yer almamalı, öğrencileri kavram yanlışlarına sürükleyecek ifadeler yer verilmemelidir. Ders kitabı fen sınıfındaki temel kaynak olarak kabul edilir ve öğretmenlerin ilk başvurdukları kaynaklardan biridir (Tulip ve Cook, 1991; Elgar, 2004). Ders kitaplarının hazırlanmasının temel amacı; kitapların öğretim programında belirlenen bilişsel, duyuşsal ve psikomotor davranışları öğrencilere kazandıracak faaliyetleri içermesi ve bu faaliyetlere rehberlik edici nitelikte olmasıdır. Bu da öğrencilerin mümkün olduğunca çok ve değişik etkinliklere yöneltilmesi ile olabilir. Ders kitaplarında konu ya da ünitenin başlangıcında öğrencilerin dikkat ve ilgisini o konuya çekmek, onları istekli kılarak hazırlamak, ünite konuları işlenirken hedeflenen davranışların kazandırılması aşamasındaki öğrenme yaşantılarını sunmak ve ünite sonunda kontrolü ve pekiştirmeyi sağlamak amaçlarıyla öğrencinin gezi, gözlem, deney ve araştırma yapmasına ve belli sonuçlara kendi kendine ulaşmasına fırsat verilmelidir (Kaptan, 1999). (Akt:Maskan , Maskan ve Atabay ,(2007).

Yapılandırmacı yaklaşım, Fen öğretim ortamlarında kullanılan materyallerde de yeniden düzenlemeler yapılmasını gerekli kılmıştır. Söz konusu öğretim materyallerinden belki de en önemlisi ders kitaplarıdır. Ders kitabı fen sınıfındaki temel bir kaynak olarak kabul edilir ve öğretmenlerin ilk başvurdukları kaynaklardan biridir (Tulip ve Cook, 1991; Elgar, 2004). Öğrenciler, yasadıkları toplumda ve dünyada olan değişiklikleri daha iyi anlayabilmek ve kavrayabilmek için olay ve olguları kavramalarını kolaylaştıracak araç ve gereçlere ihtiyaç duymaktadırlar. Bu araçların en basında da ders kitapları gelmektedir (Ceyhan ve Yiğit, 2003: 17-18). Eğitimin bütün aşamalarında kullanılan ders kitapları, öğrencilere belirli ipuçlarını veren ve onları amaçlar doğrultusunda gerekli davranışları kazanmak üzere inceleme ve araştırmaya yönelten bir araç olarak önem taşımaktadır (Morgil, Yılmaz ve Ozcan, 1999: 156).

Türkiye'deki öğrencilerin Fen ve Teknoloji dersindeki başarılarının, diğer derslere oranla önemli ölçüde düşük olduğu ve diğer ülkelere göre geride kaldığı yapılan araştırma sonuçlarından anlaşılmaktadır (OECD, 2007). Elde edilen bu sonuçlara neden olan pek çok faktör arasında, öğretmenlerin laboratuvar çalışmalarındaki yetersizlikleri de sayılabilir. Laboratuvar çalışmaları, bir yandan öğrencilerin fenle ilgili etkinliklere katılmalarına ve bilimsel yöntemi tanıyarak takdir etmelerine olanak sağlarken, diğer taraftan öğrencilerin gözlem yapmalarına, fikir üretmelerine ve yorum yapma yeteneklerinin gelişmesine katkıda bulunmaktadır (Ayas, Çepni, Akdeniz ve Kaptan, 1998). Bu yöntem ayrıca, öğrencilerde, akıl yürütme, eleştirel düşünme, bilimsel bakış açısı geliştirme, problem çözme gibi becerileri geliştirmektedir (Serin,2002). Fen eğitimi alanında çalışan birçok araştırmacı, öğretmenlerin bilimin doğasını anlamadan, öğrencilerinin fen ile ilgili kavramları anlamalarına yardım etmelerinin imkânsız olacağını vurgulamaktadır (Hadson, 1998; Palmquist ve Finley, 1997). Laboratuvar çalışmaları aracılığı ile öğrencilere kazandırılması gereken bilgiler, beceriler, tutumlar, öğretmenlerin bu konudaki bilgileri, becerileri ve tutumları ile doğru orantılıdır. Bu konuda yapılan birçok araştırmada, öğretmenler, fen öğretiminde laboratuvar çalışmalarının gerekli olduğunu vurgulamışlar ancak bu gereğin yeterince yerine getirilmediğini belirtmişlerdir (Ayas, Çepni, Akdeniz ve Kaptan, 1998; Alpagut, 1984) Öğretmenler, laboratuvar kullanmayı engelleyen faktörleri malzeme yetersizliği, ders saatinin az olması, ortamın uygun olmaması, öğrencilerin laboratuvar ortamında kontrolünün zor olması şeklinde ifade etmişlerdir (Akdeniz, Çepni, Azar,1999).

Öğretmenlerin derslerinde laboratuvara az yer vermelerinin önemli bir nedeni de eğitimleri sırasında uygulamalı eğitime yönelik yetiştirilmemeleri; deneyleri nasıl uygulayacakları, bir deneyi nasıl kurup, geliştirecekleri ve laboratuvar yöntemini nasıl kullanacakları konusunda eğitim verilmemesidir (Öztas ve Özay, 2004). Başka bir çalışmada ise, öğretmenlerin derslerinde laboratuvarı yeterince kullanamama nedenlerinin basında, laboratuvar kullanmaya yönelik çok fazla sayıda hizmet içi eğitim kurslarının açılmaması olduğu belirtilmiştir (Nakiboglu ve Sarıkaya, 1999). Aynı araştırmada düzenlenen hizmet içi eğitim kurslarının öğretmenlerin görev yaptıkları bölgelere uzak kalması nedeniyle öğretmenlerin tercih edemedikleri belirlenmiştir.

2.YÖNTEM:

Bu çalışmada nitel araştırma yöntemlerinden doküman incelemesi tekniği kullanılmıştır. Var olan kayıt ve belgeleri inceleyerek veri toplamayı “belgesel tarama” (Madge, 1965), “belgesel gözlem” (Duverger, 1973),

Rummel (1968) ve daha pek çok araştırmacı “doküman yöntemi” olarak tanımlamaktadırlar. Best (1959) ise bu yöntemi mevcut kayıt ya da belgelerin, veri kaynağı olarak, sistemli incelenmesi olarak ifade etmektedir (Karasar, 2008). Doküman incelemesi tekniği, araştırılması hedeflenen olgu veya olaylar hakkında bilgi içeren yazılı materyallerin analizini kapsamaktadır (Yıldırım ve Şimşek, 2008). Nitel araştırma yöntemlerinde veri toplanması, analizlerin yapılması ve sonuçlara ulaşma aşamalarına birden fazla araştırmacının dahil edilmesi hem araştırmacılar arasında oluşacak uzlaşma noktalarını hem de araştırma güvenilirliğini artırması bakımından önemlidir (Yıldırım ve Şimşek, 2008).

Bu çalışmada izlenen yöntem basamakları aşağıdaki şekilde düzenlenmiştir:

- 1) 2013-2014 yılında Ankara ili Kızılcahamam ilçesinde okutulan 5.Sınıf Fen Bilimleri ders kitabındaki etkinlikler laboratuvar kullanım teknikleri açısından incelenmiştir.
- 2) 2013-2014 yılında Ankara ili Kızılcahamam ilçesinde okutulan 5.Sınıf Fen Bilimleri ders kitabındaki etkinliklerin programdaki kazanımlara uygunluğu incelenmiştir.
- 3) Laboratuvar da meydana gelen kazalar laboratuvar teknikleri açısından incelenmiş ve değerlendirilmiştir.

3.BULGULAR

1) 2013-2014 yılında Ankara ili Kızılcahamam ilçesinde okutulan 5.Sınıf Fen Bilimleri ders kitabındaki etkinlikler laboratuvar kullanım teknikleri açısından incelenmesi:

5.Sınıf ders Kitabı sayfa 8’de bulunan Patatesin Gizemini Keşfedelim (Etkinlik 1.3) etkinliğinde İyot çözeltisi patates üzerine damlatılarak renk değişimi gözlenmek istenmiştir. Etkinlikte iyot çözeltisinin çözelti oranı ve iyot çözeltisinin zararları hakkında herhangi bir bilgi verilmemiştir. İyot çözeltisi, içerisinde katı iyot oranı fazla olduğu zaman solunması sakıncalı bir maddedir. İyot çözeltisinin çözelti oranları belirtilmeli, kimyasal özellikleri bilinmeli ve öğretmenlerin iyot çözeltisinin kimyasal özellikleri hakkında bilgi sahibi olmaları gerekmektedir.

5.sınıf ders Kitabı sayfa 115’te bulunan Erime ve Donma (Etkinlik 3.1) etkinliğinde, sayfa 118’de bulunan Buharlaştırma ve Yoğuşma (Etkinlik 3.2) etkinliğinde, Sayfa 120’de bulunan Süblimleşme ve Kırışma (Etkinlik 3.3) etkinliğinde, sayfa 132’de bulunan Erime ve Donma Noktası (Etkinlik 3.4) etkinliğinde, sayfa 135’te bulunan Maddenin Ayırt edici Özellikleri:Kaynama noktası(Etkinlik 3.5) etkinliğinde, Sayfa 143’te bulunan Isı ve Sıcaklık(Etkinlik 3.7) etkinliğinde, Sayfa 144’te bulunan Isı Alışverişi (Etkinlik 3.8) etkinliğinde , Sayfa 153’te bulunan 1 TL’ye Neler oluyor(Etkinlik 3.9) etkinliğinde, Sayfa 154’te bulunan Sıvılarda Genleşme ve Büzülme (Etkinlik 3.10) etkinliğinde, Sayfa 156’da bulunan Gazlarda Genleşme ve Büzülme (Etkinlik 3.11) etkinliğinde; 6.sınıf ders kitabı sayfa 107’de Madde Aynı Madde mi?(9.Etkinlik) , 6.sınıf sayfa 109 da bulunan Maddeye ne Oldu?(10.Etkinlik) , 6.sınıf ders kitabı sayfa 184’te bulunan Isıtılm Gözlemleyelim (1.Etkinlik), 6.sınıf ders kitabı sayfa 193’te bulunan Hangisi erken, Hangisi geç ısınır? (4.Etkinlik), 6.sınıf sayfa 257’de bulunan Toprak çeşitlerini keşfedelim (5.Etkinlik) etkinliklerinde ispirto ocağı kullanılmıştır. İspirtonun teknik özellikleri ve kullanım alanları ile ilgili herhangi bir bilgi verilmemiştir.

İspirtonun içeriği büyük oranda alkolden oluşmaktadır. Alkol ise çabuk alev alabilen, yanıcı özelliği sayesinde fen laboratuvarlarında ısı kaynağı olarak kullanılmaktadır. İspirto ocağı devrilme ve kırılma durumunda çabuk alev aldığı için öğrencilerde ve öğretmenlerde çeşitli yaralanmalara sebep olmaktadır.Deneylerde ispirto ocağı yerine çeker ocak kullanılmalıdır. Çeker ocaklar çalışma alanında oluşan asit buharı, ısı, proses aroması gibi gazları uzaklaştırabilecek emiş gücüne sahip, çalışma alanındaki zararlı havayı sisteme bağlı bulunan baca bağlantısı ile dış ortama atan cihazlardır. Öğretmenlerin deneyler esnasında kullandıkları malzemelerin özellikleri ve deney sırasında oluşturabileceği tehlikeleri hakkında önceden bilgi edinmeleri oldukça önem taşımaktadır. Fen ve teknoloji ders kitapları öğretmen ve öğrenciler için birincil kaynak olduğundan ders kitapları laboratuvar kullanım tekniği konusunda bilgiler içermelidir. Ayrıca öğretmenler deney esnasında öğrencileri deney düzeneğine çok fazla yaklaştırmamalı, belirli bir mesafeden izlemelerini sağlamalıdır.

5.sınıf ders Kitabı sayfa 120’de Süblimleşme ve Kırışma (Etkinlik 3.3) etkinliğinde Naftalin kullanılmıştır. Deneyde naftalin bir kap içerisinde ısıtılarak süblimleştirilmektedir.

Naftalin, oda şartlarında süblimleşen bir madde olduğu için solunması akciğerlerde zararlara neden olacağı için solunmamalıdır. Etkinlik 3.3’te naftalin kabının ağzı açık vaziyette ısıtıldığı için öğrenciler tarafından solunacaktır. Naftalin, havada kolayca süblimleşebilen beyaz bir katı maddedir. Petrol, kömür gibi fosil

yakıtlarında doğal olarak bulunur. Hava ile karışınca yanıcı özellik gösterir. Naftaline temas etmenin ve uzun süre naftaline maruz kalmanın sağlık açısından zararları vardır. Uzun süre ya da aşırı solunması sonucu kırmızı kan hücrelerine zarar verir. Bitkinlik, halsizlik, solgun beniz gibi belirtileri olan kansızlık rahatsızlığı baş gösterebilir. Ayrıca mide bulantısı, baş dönmesi, kusma, bayılma, ciğerlerde hasar meydana getirebilir. Gözleri de tahriş edebilir. Sadece solunum yoluyla değil temas edilmesi durumunda cilt ile de vücuda geçebilir ve çeşitli zararlar meydana getirebilir. Deney kapalı bir kaptayla yapılırsa ortama süblimleşen naftalin ulaşmayacak ve öğrenciler zarar görmeyecektir.

5.sınıf Ders Kitabı sayfa 135'te Maddenin Ayırt edici özellikleri: Kaynama noktası (Etkinlik 3.5) etkinliğinde, etil alkol açık ortamda bulundurulmakta ve kaynatılmak suretiyle buharlaştırılmaktadır. 6.sınıf Ders Kitabı sayfa 130'da bulunan Hangi Maddeler Elektrik enerjisini iletir? (1.Etkinlik) etkinliğinde Etil Alkol açık ortama bırakılmış elektrik iletkenliğine bakılması istenmiştir.Etil alkol açık ortama bırakıldığı zaman buharlaşacak ve zehirlenmelere neden olabilecektir.

Etil Alkol; Sıcak yüzeylerle veya alevle temasında patlayıcı özellik gösterir.Kolay tutuşur. Deri ve göz ile temasında tahribatlara sebep olur. Yutulduğunda ve teneffüs edildiğinde tahriş edici özelliği vardır. Yutulduğu zaman ve solunduğu zaman zehirlenmelere yol açar.Deneyde Etil alkol kaynatıldığında gaz hali başka bir kaba aktarılarak öğrencilere gösterilebilir.Etil alkol kullanılırken eldiven ve maske kullanılmalıdır.

6.sınıf Ders Kitabı sayfa 89'da bulunan İyoda ne oldu? (2.Etkinlik) etkinliğinde katı iyot saat camı üzerine bırakılmış. Katı iyot oda sıcaklığında süblimleşen bir madde olduğu için buharı göz ve akciğerlere zarar verecektir. Deneyde katı iyot kapalı bir kaptayla muhafaza süblimleştirilebilir.

2) 2013 ve 2014 yılında Ankara ili Kızılcahamam ilçesinde okutulan 5.sınıf ders kitaplarında etkinliklerin kazanımları karşılayıp karşılamadığı ile ilgili de aşağıdaki bulgulara rastlanmıştır.

Tablo 1:5.SınıfFen Bilimleri Ders Kitabı (MEB yayınları, Evos Basım, Ankara 2013)

Ünite	Konu	Etkinlik	Kazanım	Etkinliğin Kazanımı Sağladığına Yönelik Değerlendirme
1.ÜNİT E: VÜCUDUMUZUN BİLMECESİNİ ÇÖZELİM	Besinler ve içerikleri	Etkinlik 1.1	5.1.1.1. Besin içeriklerinin, canlıların yaşamsal faaliyetleri için gerekli olduğunu fark eder.	Etkinlikler kısmen uygun çünkü sadece proteinlerin ve yağların yararına yöneliktir. Karbonhidratların yararını anlatan bir etkinlik yapılmamış; sadece protein,yağ ve karbonhidratların içerikleri belirlenmiş. Dolayısıyla etkinlikler kazanımı karşılamamaktadır.
		Etkinlik 1.2		
		Etkinlik 1.3		
Etkinlik 1.4				
Etkinlik 1.5				
Etkinlik 1.6				
Besinlerin Sindirimi	Etkinlik 1.15	5.1.2.3. Diş sağlığı için beslenmeye, temizliğe ve düzenli diş kontrolüne özen gösterir	Etkinlik kazanımı karşılamıyor. Etkinlik sadece diş ağrısının sebepleri üzerinde öğrencileri düşündürüyor.Konuyla ilgili daha kapsamlı bir etkinlik hazırlanabilirdi.	
	Etkinlik 1.14	5.1.2.4. Besinlerin sindirildikten sonra vücutta kan yoluyla taşındığı çıkarımını yapar.	Etkinlikler kazanımı karşılamıyor. Burada öğrenciler besinlerin kan yoluyla taşındığı çıkarımını yapamıyor, sadece besinlerin izlediği yolu görüyor.	
3.ÜNİT E:MADDENİN DEĞİŞİMİ	Maddenin değişimi	Etkinlik 3.1	5.3.1.1. Maddelerin ısı etkisiyle hâl değiştirebileceğine yönelik deneyler	Kısmen uygun(Etkinlik 3.3 te naftalinin süblimleşecektir. Bu durumda tehlikeli tehlikeli sonuçlar ortaya çıkaracaktır.)Naftalin kapalı bir kaptayla ısıtılırsa tehlikeli sonuçlar
Etkinlik 3.2				

Mİ		Etkinlik 3.3	yapar, elde ettiği verilere dayalı çıkarımlarda bulunur.	ortadan kalkacaktır.
4.ÜNİT E:İŞİĞİ N VE SESİN YAYIL MASI	Sesin Yayılması	Etkinlik 4.6 Etkinlik 4.7 Etkinlik 4.8	5.4.4.1. Sesin yayılabildiği ortamları tahmin eder ve bu tahminlerini test eder.	Etkinlik 4.8 de sesin gaz ortamda yayılması ile ilgili farklı gaz ortamlarda etkinlik olsaydı, konunun anlaşılması daha etkili olabilirdi.
	Sesin Farklı ortamlarda farklı duyulması	Etkinlik 4.9	5.4.5.1. Farklı cisimlerle üretilen seslerin farklı olduğunu deneyerek keşfeder.	Kısmen uygun Çünkü, burada kullanılan madde sayısı az olmuş, daha fazla madde kullanılarak çıkardığı seslere bakılabilir.
5.ÜNİT E:CANLILAR DÜNYASINI GEZELİM TANIYALIM	Canlıları Tanıyalım	Etkinlik 5.1 Etkinlik 5.2 Etkinlik 5.3 Etkinlik 5.4	5.5.1.1. Canlılara örnekler vererek benzerlik ve farklılıklarına göre gruplandırır.	Kısmen Uygun(Öğrencilerin mantarların yapısını gözleyebileceği, çevresindeki hayvanları gözlediği ve bunları birbiriyle kıyaslayabileceği bir etkinlik tasarlanabilirdi.)
	İnsan ve Çevre İlişkisi	Etkinlik 5.5 Etkinlik 5.6	5.5.2.1. İnsan faaliyetleri sonucunda oluşan çevre sorunlarını araştırır ve bu sorunların çözümüne ilişkin önerilerde bulunur.	Kısmen uygun Çünkü etkinlik 5.5 te öğrencilerin yaşı küçük olduğu için yaşadıkları çevredeki geçmişten günümüze kadar olan değişimleri fark edemeyebilirler. Yine Etkinlik 5.6 da çevre sorunlarına karşı çözüm önerileri belirtilmemiş, sadece hava kirliliğinin nasıl oluştuğu anlatılmış.
7.ÜNİT E:YERKABUĞUNUN GİZEMİ	Yerka buğunda Neler Var?	Etkinlik 7.2	5.7.1.2. Kayaçlarla madenleri ilişkilendirir ve madenlerin teknolojik ham madde olarak önemini tartışır.	Kısmen uygun çünkü sadece altın madeni ile ilgili etkinlik verilmiş. Diğer madenleri de kapsayan etkinlikler olabilirdi.Etkinlik kazanımı karşılamamaktadır.
		Etkinlik 7.3	5.7.1.3. Fosillerin oluşumunu ve fosil çeşitlerini araştırır ve sunar.	Kısmen uygun çünkü etkinlik fosillerin oluşumunu gösteriyor ama fosil çeşitleriyle ilgili bilgi sunmuyor. Fosil çeşitlerini de içeren bir etkinlik olabilirdi.

Tablo 1 de de görüldüğü gibi, bazı etkinlikler laboratuvar kullanım teknikleri açısından uygun değilken, bazı etkinlikler de ilgili olduğu kazanımı karşılamamaktadır. Ayrıca 5.sınıf ders kitaplarında pek çok kazanıma yönelik herhangi bir etkinlik bulunmamaktadır.

3)Laboratuvardaki kazaların laboratuvar teknikleri açısından incelenmesi ve değerlendirilmesi;

Laboratuvarlarda meydana gelen kazalar incelendiğinde çoğunlukla,civa zehirlenmesi, deney tüpü patlaması, kimyasal maddelerin yayılması, gaz çıkışı, ispirto tüpünün patlaması, çakmak tüpü patlaması, ampul patlaması

ile ilgili oldukları görülmektedir. Bu kazaların başlıca sebepleri; öğretmen ve öğrencilerin kimyasal maddelerin özellikleri hakkında yeterince bilgi sahibi olmamaları ya da yanlış bilgi sahibi olmaları, kimyasal maddelerin döküldüğünde ya da yayıldığında nasıl müdahale edileceğinin bilinmemesi, deney sırasında yapılan dikkatsizlikler, öğretmen gözetimi olmaksızın öğrencilerin deney malzemelerini bilinçsizce kullanmaları ve deney süresinde meydana gelebilecek tehlikeler karşısında nasıl bir davranış tarzı geliştirileceğinin bilinmemesi olarak gösterilebilir. Ayrıca, laboratuvarla ilgili öğretim programında kazanımlar yer almamaktadır. Eğer öğretim programında laboratuvar kullanım teknikleri ile ilgili kazanımlara yer verilirse öğretmenler kimyasal maddelerin özelliklerini ve laboratuvar kullanım tekniklerini öğrenme konusunda kendilerini daha zorunlu hissedeceklerdir. Sonuçta laboratuvar kazalarının da önüne geçilmiş olacaktır.

4. TARTIŞMA VE SONUÇ

5. sınıf Fen Bilimleri ders kitaplarındaki etkinlikler incelendiğinde de görüldüğü gibi; bazı etkinliklerin laboratuvar kullanım teknikleri açısından uygun olmadığı gözlenmiştir. Etkinliklerde en sık gözlenen sorunlar; ispiro ocağının kullanımından kaynaklanabilecek tehlikeler, Naftalinin açık şekilde kullanılarak süblümleşip ortama yayılması, Katı iyot çözeltisinin açıkta kullanılması, İyot çözeltisinin hangi oranda kullanılacağına belirtilmemesi,

Etil alkolün açıkta kullanılması gibi durumlar olmuştur. Etkinliklerin laboratuvar kullanım tekniklerine dikkat edilmeden hazırlanmasından dolayı laboratuvar kazaları meydana gelmektedir. Yapılan araştırmalar da bu verileri destekleyen sonuçlar ortaya koymaktadır.

Aydoğdu ve Yardımcı (2013) çalışmalarında Laboratuvar kazalarının başlıca sebeplerini; öğretmen ve öğrencilerin kimyasal maddelerin özellikleri hakkında yeterince bilgi sahibi olmamaları ya da yanlış bilgi sahibi olmaları, kimyasal maddelerin döküldüğünde ya da yayıldığında nasıl müdahale edileceğinin bilinmemesi, deney sırasında yapılan dikkatsizlikler, öğretmen gözetimi olmaksızın öğrencilerin deney malzemelerini bilinçsizce kullanmaları ve deney süresinde meydana gelebilecek tehlikeler karşısında nasıl bir davranış tarzı geliştirileceğinin bilinmemesi olarak gösterilebilir. Bu kaza sebepleri, öncelikle fen laboratuvarında kullanılan kimyasal maddeler ve değişik deney malzemelerinin tanınması, kullanım şekillerinin çok iyi bilinmesi gerekliliğini ve laboratuvar kullanım tekniği bilgisinin eksikliği olarak göstermektedirler. Morgil ve Yılmaz (2000), yaptıkları araştırmada öğrencilere uygulamalara başlarken yapacakları deneylerin nasıl güvenli bir şekilde yapılacağı ile ilgili ön bilgilerin verilmesi gerekliliğini rapor etmişlerdir (Akt; Yılmaz, Uludağ ve Morgil, 2001). Öğretmenlerin laboratuvarında bilgi ve beceri eksikliğinin uygulamalar sırasında isteksiz olmalarına sebep olduğu da birçok araştırmacı tarafından vurgulanmıştır (Aydoğdu 1999; Coştu, Ayas, Çalık, Ünal ve Karataş 2005). Yapılan başka çalışmalar sadece ilköğretim düzeyinde değil, lise ve üniversite düzeyindeki öğrencilerin de deney malzemelerinin kullanımını konusunda zorluk çektiklerini göstermiştir. Temiz ve Kanlı (2005) lise 1, 2 ve 3 fizik ders kitaplarındaki deneylerde en çok adı geçen ve kullanılan laboratuvar araçlarının öğrenciler tarafından ne derecede tanındığını ve bilindiğini ortaya çıkarmak için yaptıkları araştırmalarında, liseden yeni mezun olan öğrencilerin büyük bir çoğunluğunun ampermetre, voltmetre ve dinamometre dışındaki birçok laboratuvar aracının adını ve ne işe yaradığını bilmeklerini ortaya çıkarmıştır. Harman (2011), sınıf öğretmeni adayları ile yaptığı çalışmada öğretmen adaylarının fen ve teknoloji öğretiminde yapılan deneylerde sıklıkla kullanılan araç-gereçler, mikroskobun kısımları, bu kısımların görevleri ve mikroskobun kullanımı ile ilgili bilgi sahibi olmalarının yanı sıra bu konuda bazı eksik ya da yanlış bilgilere sahip oldukları sonucuna ulaşmıştır. Ayrıca kimyasal maddelerin üzerinde bulunan tehlike işaretlerinin anlamlarının bilinip bilinmediği konusunda yapılan çalışmalara da rastlanmıştır (Anılan, 2010). Yılmaz, Uludağ ve Morgil (2001)'in araştırmasında üniversite öğrencilerinin bile organik kimya laboratuvarında kullanılan bazı çözücü ve maddelerin toksik etkileri ve korunma yöntemlerine ilişkin bilgilerinin orta ve az derecede olduğu ortaya çıkmıştır ki ilköğretim öğrencilerinin bu konuda daha dikkatli olmaları beklenmektedir. İlköğretim düzeyindeki deneylerde çok çeşitli ve fazla sayıda kimyasal kullanımı gerekeceğinden zararlı kimyasallar yerine günlük yaşamda kullanılan, daha hafif ve o kimyasalın yerini tutabilecek başka maddeler öğretmenler tarafından kontrollü bir şekilde kullanılarak kaza riski azaltılabilir. Nitekim kazaların meydana gelme sebepleri irdelendiğinde birinci sorumlu olarak öğretmenler karşımıza çıkmaktadır. Öğretmenlerin olası kazalar ve riskler karşısında yerleşmiş bir davranış tarzı geliştirmeleri ve bu konuda donanımlı olmaları büyük önem taşımaktadır. Ayrıca ders kitaplarında yer alan deneylerde kullanılan kimyasal malzemeler ve diğer malzemeler ile ilgili yeterli düzeyde bilgi verilmesi gerekmektedir. Yılmaz (2005)'in çalışmasında lise-1 kimya ders kitabında yer alan deneyler incelenmiş ve bu deneylerde kullanılan kimyasal maddeler ile ilgili insan sağlığı ve laboratuvar güvenliği açısından uyarıcı nitelikteki bilgilerin yeterlilikleri araştırılmıştır. Çalışmanın sonuçları, lise-1 kimya ders kitabında deneysel uygulamalarda kullanılan kimyasal maddelere ilişkin hiçbir güvenlik bilgisinin verilmediğini ortaya çıkarmıştır. Güneş, Şener, Germi ve Can(2013) çalışmalarında, okullarda laboratuvar bulunmasına rağmen laboratuvar etkinliklerine veya deneysel uygulamalara yeterince yer verilmediği, ayrıca

günlük yaşamda kullanılan malzemelerle yapılabilecek deneylerin bile uygulama yapılmadan geçirildiği ortaya çıkmaktadır. Çalışma sonuçlarına göre öğretmenlerin yaklaşık olarak yarısının okulda bulunan araç-gereçlerin yetersiz olması nedeniyle, önemli bir kısmının da laboratuvarların yetersiz olması nedeniyle fazla deney yapamadığı, deney yapamayan öğretmenlerin de çoğunlukla yanlarında götürdükleri basit malzemeler ile sınıflarda uygulama yaptıkları veya modeller ile ders anlattıkları dikkati çekmektedir. Öğrencilerin de önemli bir kısmı laboratuvarda araç-gereç yetersizliği nedeniyle deney yapılamadığını belirtirken bir kısmı ise öğretmenlerinin deney yapmak istemediğini, bazı öğretmenlerin ise sınıfa getirdikleri malzemeler veya modeller ile ders anlatılmasının ise çoğunlukla biyoloji ünitelerinde gerçekleştiğini, fizik ve kimya konularında ise öğretmenlerin sınıf içi uygulamalar için fazla malzeme kullanmadıklarını ifade etmişlerdir. Fen bilimleri ile ilgili öğretmen adaylarının laboratuvar kullanımı konusunda eksik olduğu, dolayısıyla bu öğretmenlerin yeterli düzeyde laboratuvar kullanmayacakları ve bu nedenle öğretmen adaylarının deney yapma konusunda temel bilgi ve becerilerinin mutlaka yeterli olacak şekilde eğitilmesi gerektiği (Coştu ve diğer., 2005) ileri sürülmüştür (Akdeniz ve diğer., 1999). Fen eğitiminin laboratuvara dayalı deneysel olarak yapılması ise bilginin teoriden pratiğe ve günlük yaşama dönüştürülmesini kolaylaştıracaktır, ayrıca laboratuvarda deneyip yanılarak veya hata yaparak öğrenen öğrenciler öğrendiklerinden gerçek yaşamda yararlanma şansını elde etmiş olacaktır.

5.Sınıf Fen Bilimleri kitabındaki etkinliklerin programdaki kazanımlara uygunluğu incelendiğinde, bazı etkinliklerin kazanımın içeriğini tam karşılamadığı ve bazı etkinliklerin de kazanıma uygun olmadığı belirlenmiştir. Bazı kazanımlara karşılıkta hiçbir etkinliğin olmadığı gözlenmiştir. Çalışmada incelediğimiz etkinlikler sırasında kimyasal malzemelerin özellikleri ve tehlikeleri hakkında yeterli bilgi verilmediği için, öğretmen ve öğrenciler etkinlikleri yaparken çeşitli kazalara maruz kalabilmektedir. Bazı etkinliklerin etkili olduğu kazanımı karşılamaması ve bazı etkinliklere yönelik kazanım bulunmaması, konunun anlaşılmasını zorlaştıracaktır. Öğretmenlerin daha önceki eğitimlerinde laboratuvar teknikleri ile ilgili yeterli bilgi sahibi olmamaları ve kimyasal maddelerin özelliklerini bilmemelerinden dolayı ya bu etkinlikleri hiç yapmadıkları ya da yaparken kazalar yaşadıkları görülmektedir. Eğer ders kitaplarındaki etkinlikler kazanımları tam olarak karşılırsa, öğrencilerin konuyu öğrenmeleri daha kolay olacaktır. Fen derslerinde etkinlik öğretimi önemli bir yere sahiptir. Eğer etkinlikler öğrenciler tarafından tam olarak anlaşılmazsa konunun öğrenilmesi de çok zor olacaktır. Öğrencilerin etkinlikleri yapmaları sayesinde öğrenci merkezli öğrenme de gerçekleşecektir. Ders kitapları hazırlanırken kazanımlar daha dikkatle, taranmalı, mümkünse her kazanımı karşılayan bir etkinlik bulunmalıdır. Hazırlanan kazanımların ilgili olduğu kazanımın içeriğini eksiksiz olarak karşılaması gerekmektedir. Çünkü bazı etkinliklerin ilgili olduğu kazanımların tamamını kapsamadığı, veya kısmen kapsadığı görülmüştür. Bazı etkinliklerde de laboratuvar kullanım teknikleri açısından sorunlar gözlenmiştir. Etkinlikler hazırlanırken laboratuvar kullanım teknikleri de dikkate alınmalıdır.

Maskan, Maskan ve Atabay(2007) çalışmalarında, ders kitaplarının eksiksiz, abartısız ve hatasız olması gerektiğini, eğer, öğrencilerin eksik ve yanlış bilgi sahibi olurlarsa, çevrelerinde olup bitenleri, sahip oldukları ve değiştirmedikleri yanlış kavramlarla açıklamaya çalışacaklarını ve ilköğretim döneminde öğrencilerin zihinlerinde yerleşen yanlış kavramların ileride telafi edilmesinin kolay olmayacağını belirtmişlerdir. İnaltekin, Özyurt ve Akçay (2012) çalışmalarında, ders kitaplarındaki etkinliklerin içerikleri anlama-öğrenme alanlarına göre incelendiğinde tüm sınıf düzeylerindeki kitaplarda etkinliklerin dinleme ve konuşmaya dayandırıldığı gözlemiştir. Bununla beraber yazma ve okuma temelli etkinliklere daha az yer verildiğini, 6., 7. ve 8. sınıflar düzeyinde etkinlikler incelendiğinde deneylerin kitaplarda çok geniş bir yer kapladığı sonucuna ulaşılmıştır. İncelenen üç kitapta da deneyleri çizelge doldurma etkinlikleri izlemiştir. 6. ve 8. sınıf kitaplarında metin yazma ve tamamlama, şiir, şarkı sözü yazma ve drama gibi fen eğitiminin genel amaçlarında da vurgulandığı gibi öğrencilerin öğrendiklerini yazıya aktaracakları etkinliklere hiç yer verilmediği belirlenmiştir. Ayvacı ve Ernas (2009) çalışmalarında, Yaratıcı bireyler yetiştirilmesinde de ders kitaplarındaki etkinliklerin önemli bir rolü vardır. Ders esnasında kullanılan bu etkinliklerle öğrencilerin öğrendiklerini anlamlandırmaları amaçlanmaktadır. Bunun kalıcı olabilmesi ve öğrencinin etkinlikleri ilgisi dağılmadan yapabilmesi için içeriğin iyi hazırlanması gerekir. Aynı zamanda ders kitaplarında yer alan etkinlikler çeşitlendirilmesi gerektiğini belirtmişlerdir. Erdoğan (2007), yapmış olduğu çalışmasının sonucunda yeni öğretim programının etkili bir şekilde uygulanabilmesi için alt yapı ve materyal eksikliğinin olmaması ve gerekli kaynakların öğretmenlere sağlanması gerektiğini belirtmiştir. Dindar ve Yangın (2007), yeni hazırlanan programın program geliştirme uzmanları tarafından teorik olarak uygun görünmesine rağmen, uygulama koşullarına uygun olmayan bir programın başarısının zayıf olacağını belirtmişlerdir. Öğretmenler açıkça materyal ve araç-gereç eksikliği çektiğini ifade etmişlerdir.

Etkinlikleri uygulama sürecinde öğretmenler birtakım destekleri de görmeyi beklemektedirler. Birçok öğretmen laboratuvar ortamının fiziki donanım açısından yetersiz olduğunu dile getirmekte ve deneylerinin sağlıklı bir şekilde yapılamadığından şikâyet etmektedir. Yetersiz bir laboratuvar ortamı tehlikenin boyutlarını artırmakta, kazaları tetiklemektedir. Bu durumda Milli Eğitim Bakanlığı'nın okullarla ve öğretmenlerle sıkı bir

işbirliği içinde olması gerektiği karşımıza çıkmaktadır. Fiziki donanım sağlandıktan sonra, deneyler sırasında öğretmene rehberlik edecek kılavuz kitapçıkları ve de fen teknoloji ders kitapları belli uzmanlar tarafından laboratuvar kullanım tekniğine uygunluğu araştırılarak kullanıma sunulmalıdır. Laboratuvar kullanım tekniği konusunda öğretmenlerin bilgilendirilmesi gerekmektedir. Bu bilgilendirmenin yapılabilmesi için ise hizmet içi eğitim kursları önemli hale gelmektedir. Bu kurslarla öğretmenlere ve üniversite eğitimi alan öğretmen adaylarına iyi bir laboratuvar kullanım tekniği verilmelidir. Laboratuvar çalışması öncesi, çalışma sırasında ve çalışma sonrasında uygulanması gerekli kurallar, deneylerde kullanılan kimyasalların kullanım teknik ve yöntemi ve deneyde kullanılan araç – gerecin kullanımına yönelik teknik bilgilerin tümü laboratuvar kullanım tekniği olarak isimlendirilebilir.(Aydoğdu, Yardımcı 2013)

Sonuç olarak; ders kitaplarındaki etkinlikler hazırlanırken, etkinliklerin kazanımları karşılmasına, uygulanmasının kolay olmasına ve laboratuvar kullanım tekniklerine uygun olmasına dikkat edilmelidir. Öğretim programında laboratuvar teknikleriyle ilgili de kazanımlarında bulunması gerekmektedir.Fakültelerin fen bilimleri öğretmeni yetiştiren bölümlerinde laboratuvar tekniklerine önem verilmelidir.

KAYNAKLAR

- Akinoğlu, O. Şahin, F. ve Gürdal, A. (2002). Fen bilgisi ders kitaplarının kavram haritası çizilerek değerlendirilmesi, V. Ulusal Fen Bilimleri ve Matematik Eğitimi Kongresi, ODTÜ, Ankara
- Anılan, B. (2010). The recognition level of the students of science education about the hazard symbols of chemicals. *Procedia Social and Behavioral Sciences*, 2, 4092-4097.
- Aycan, Ş., Kaynar, Ü.H., Türkoğuz, S. ve Arı, E. (2002). İlköğretimde kullanılan fen bilgisi ders kitaplarının bazı kriterlere göre incelenmesi, V. Ulusal Fen Bilimleri ve Matematik Eğitimi Kongresi Bildiri Özetleri, ODTÜ Eğitim Fakültesi, Ankara.
- Aydoğdu, C, Yardımcı E, (2013). Hacettepe Üniversitesi Eğitim Fakültesi Dergisi [H. U. Journal of Education] 44: 52-60
- Aydoğdu, M. & Kesercioğlu, T. (2005). *İlköğretimde Fen ve Teknoloji Öğretimi*, Anı Yayıncılık, Ankara. Aydoğdu,
- C. (1999). Kimya laboratuvar uygulamalarında karşılaşılan güçlüklerin saptanması. *H.Ü. Eğitim Fakültesi Dergisi*, 15, 30-35.
- Ayas, S. Çepni, A.R. Akdeniz, “Fen Bilimleri Eğitiminde Laboratuvarın Yeri ve Önemi Tarihsel Bir Bakış”, *Çagdas Eğitim*, 204, 22-23 (1994).
- Ayvacı, Ş, Ernas, S (2009). “Öğretmen Kılavuz Kitaplarının Yapılandırıcı Kurama göre Öğretmen Görüşlerine Dayalı Olarak Değerlendirilmesi” Necatibey Eğitim Fakültesi Elektronik Fen ve Matematik Eğitimi Dergisi (EFMED) Cilt 3, Sayı 2, Aralık 2009, sayfa 212-225.
- A. R. Akdeniz, S. Çepni, A. Azar, “Fizik öğretmen adaylarının laboratuvar kullanım becerilerini geliştirmekiçin bir yaklaşım”, *III. Ulusal Fen Bilimleri Sempozyumu*, Trabzon, MEB Basımevi, Ankara, 118-125 (1999).
- Balım, Enel ve Evrekli, E. (2007). İlköğretim Altıncı Sınıf Fen ve Teknoloji Ders Kitabının İncelenmesi ve Ders Kitabına İlişkin Öğrenci Görüşleri. Famagusta, Turkish Republic of Northern Cyprus: VI. International Educational Technologies Conference. (3-4-5. Mayıs 2007).
- Best, J.W. (1959). *Research in Education*. Prentice Hall.
- B. Palmquist and F. Finley, “Pre-service teachers’ views of the nature of science during a postbaccalaureate science teaching programme”, *Journal of Research in Science Teaching*, 34, 595-616 (1997).
- Ceyhan, E. ve Yiğit, B. (2003). *Konu Alanı Ders Kitabı İncelemesi*. Ankara: Anı Yayıncılık.
- Coştu, B, Ayas, A., Çalık, M., Ünal, S., Karataş, F.Ö. (2005). Fen öğretmen adaylarının çözeltileri hazırlama ve laboratuvar malzemelerini kullanma yeterliliklerinin belirlenmesi. *Hacettepe Üniversitesi Eğitim Fakültesi Dergisi*, 28, 65-72.

- C. Nakiboglu ve S. Sarıkaya, “Ortaöğretim kurumlarında kimya derslerinde görevli öğretmenlerin laboratuvarlardan yararlanma durumlarının değerlendirilmesi”, *D.E.Ü. Buca Eğitim Fakültesi Dergisi Özel Sayı*, 11, 395-405 (1999).
- Demirbaş, M. (2008). İlköğretim 6. sınıf fen ve teknoloji ders kitaplarının belirli değişkenler bakımından incelenmesi, *Dicle Üniversitesi Ziya Gökalp Eğitim Fakültesi Dergisi* 11, 53-68.
- Dindar, H., & Yangın, S. (2007). İlköğretim fen ve teknoloji dersi öğretim programına geçiş sürecinde öğretmenlerin bakış açılarının değerlendirilmesi. *Kastamonu Eğitim Dergisi*, 15(1), 185–198.
- Duverger, M. (1973). Sosyal Bilimlere Giriş: Metodoloji açısından. Bilgi Yayınevi, Ankara.
- D. Hadson, “Towards a philosophically more valid science curriculum”, *Science Education*, 72, 19-40 (1998).
- Elgar, A.G. (2004). Science textbooks for lower secondary schools in Brunei: Issues of gender equity. *International Journal of Science Education*, 26(7), 875–894.
- Erdoğan, M. (2007). Yeni geliştirilen dördüncü ve beşinci sınıf fen ve teknoloji dersi öğretim programının analizi: Nitel bir çalışma. *Türk Eğitim Bilimleri Dergisi*, 5,2, 221–259.
- F. Kaptan, “*Fen Bilgisi Öğretimi*”, Anı Yayıncılık, Ankara (1998).
- Güneş,H, Şener N, Topal Germi.N, Can N (2013) “fen ve teknoloji dersinde laboratuvar kullanımına yönelik öğretmen ve öğrenci değerlendirmeleri” *Dicle Üniversitesi Ziya Gökalp Eğitim Fakültesi Dergisi*, 20 (2013) 1-11
- G. Serin, “Fen Eğitiminde Laboratuvar”, *Fen Bilimleri Eğitimi Sempozyumu*, Maltepe Üniversitesi, 403–406(2002).
- Harman, G. (2011). Analysis of the prospective elementary teachers’ indormations about laboratory equipments that are used in science and technology teaching. *2nd International Conference on new trends in education and their implications*, 27-29 april, Antalya Türkiye.
- H. Öztas ve E. Özay, “Biyoloji öğretmenlerinin biyoloji öğretiminde karşılaştıkları sorunlar (Erzurum Örneği)”,*Kastamonu Eğitim Dergisi*, 12(1), 69-76 (2004).
- İnaltekin.B, Özyurt.B, Akçay.H(2012). “İlköğretim 6., 7. ve 8. Sınıf Fen ve Teknoloji Ders Kitabı Etkinliklerinin İncelenmesi”, *Trakya Üniversitesi Eğitim Fakültesi Dergisi 2012, Cilt 2, Sayı 2*, 63-73
- Karasar, N. (2008). Bilimsel Araştırma Yöntemi. Nobel Yayın Dağıtım Tic. Ltd. Şti: Ankara.
- Kaptan, F. (1999). *Fen Bilgisi Öğretimi, Öğretmen Kitapları Dizisi*, Milli Eğitim Basımevi,İstanbul.
- Koseoğlu, F., Atasoy, B., Kavak, N., Akkus, H., Budak, E., Tumay, H., Kadayıfçı, H. ve Tasdelen, U. (2003). *Yapılandırıcı Öğrenme Ortamı için Bir Fen Ders Kitabı Nasıl Olmalı*. Ankara: Asil Yayın Dağıtım.
- Lubben, F., Campbell, B., Kasanda, C., Kapenda, H., Gaoseb, N. ve Marenga-Kandjeo, U. (2003).
- Martini, D. J. (1997). *Elementary Science Methods: A constructivist Approach*, DelmarPublisher, newyork, USA.
- Madge, J. (1965). The Tools of Science an Analytical Description of Social Science Techniques. Anchor Books Doubleday and Company.
- Maskan, A.K, Maskan, M.H, Atabay, K. (2007). İlköğretim 4. sınıf fen ve teknoloji ders kitabının değerlendirme ölçütleri yönünden incelenmesi, *Dicle Üniversitesi Ziya Gökalp Eğitim Fakültesi Dergisi*, 9, 22-32.
- MEB (Milli Eğitim Bakanlığı). (2006) İlköğretim Fen ve Teknoloji Dersi (6-8) Öğretim Programı, Ankara.
- MEB (Milli Eğitim Bakanlığı). Talim ve Terbiye Kurulu Başkanlığı. (2005a). İlköğretim Fen ve Teknoloji Dersi 4. ve 5. Sınıflar Öğretim Programları Kitabı. Ankara: Milli Eğitim Basımevi.
- Morgil, F. Đ., Yılmaz, A. ve Ozcan, F. (1999). Orta Öğretimde Kimya I, II, III Ders Kitaplarının Değerlendirilmesi. *D.E.U. Buca Eğitim Fakültesi Dergisi Özel Sayı*. 11. 156-165.
- Nakipoğlu, C., ve Sarıkaya, Ş. (1999). Ortaöğretim kurumlarında kimya derslerinde görevli öğretmenlerin laboratuvarlardan yararlanma durumunun değerlendirilmesi. *Dokuz Eylül Üniversitesi Buca Eğitim Fakültesi Dergisi (Özel Sayı)*, 11, 395-405.
- OECD 2007 “Executive Summary PISA 2006: Science Competencies for Tomorrow’s World”, <http://www.oecd.org/document/2/>, (2007).
- O. Alpagut, “*Fen Öğretmenin Verimli ve _slevsel Hale Getirilmesi*”, *Ortaöğretim Kurumlarında Fen Öğretimi ve Sorunları Sempozyumu*, 12-13 Haziran, Ankara (1984).
- Rummel, J.F. (1968). An Introduction to Research Procedures in Education. Second edition, Harper and Row.
- Tulip, D., ve Cook, A. (1991). A comparison of author intentions and student perceptions about textbook characteristics. *Research in Science Education*, 21(1), 313-319.
- Tunç, T., Agalday, M., Akçam, H.K., Çeltikli Altunoğlu, Ü., Bağcı, N., Bakar, E., Başdağ, G., İnal, İpek, İ., Keleş, Ö., Gürsoy-Köroğlu, N., Yörük, N. (2010). İlköğretim Fen ve Teknoloji 6. Sınıf Öğretmen Klavuz Kitabı, MEB Devlet Kitapları. Ankara.

- Unsal, Y. ve Gunes, B. (2003). Đlkoęretim 6. Sınıf Fen Bilgisi Ders Kitabının Fizik Konuları
Yonunden Đncelenmesi. *Gazi Eęitim Fakultesi Dergisi*, 23(3), 115-130.
- West, S.S., Westerlund, J.F., Nelson, N.C., Stephenson, A.L., Nyland, C.K., (2002). What the safety research
Says to Texas
Science Teachers. *The Texas Science Teachers*, 31, 11-15.
- Yılmaz, A. (2004). Lise-3 kimya ders kitabında mevcut deneylerde kullanılan kimyasalların insan saęlığı ve
güvenlięi
aısından tehlikeli özelliklerine yönelik öğrencilerin bilgi düzeyleri ve öneriler. *Hacettepe Üniversitesi
Eęitim
Fakültesi Dergisi*, 27, 251-259.
- Yılmaz, A. (2005). Lise 1 Kimya Ders kitabındaki bazı deneylerde kullanılan kimyasalların tehlikeli
özelliklerine yönelik
öğrencilerin bilgi düzeyleri ve öneriler. *Hacettepe Üniversitesi Eęitim Fakültesi Dergisi*, 28, 226-235.
- Yılmaz, A., Uludaę, N. ve Morgil, İ. (2001). Üniversite öğrencilerinin organik kimya laboratuvar teknięine ait
temel bilgileri,
uygulamaların yeterlilięi ve öneriler. *Hacettepe Üniversitesi Eęitim Fakültesi Dergisi*, 21, 151-157
- Yıldırım, A. ve Şimşek, H. (2008). *Sosyal Bilimlerde Nitel Araştırma Yöntemleri*. Ankara: Seçkin Yayıncılık.

ABOUT 8th GRADE STUDENTS' SKILLS IN TRANSLATING AMONG MULTIPLE REPRESENTATIONS

Ramazan GÜRBÜZ
Adıyaman Üniversitesi
rgurbuz@outlook.com

Seda ŞAHİN
Adıyaman Üniversitesi
seda.sahin@windowslive.com

ABSTRACT: The aim of this study is to find out 8th grade students' skills in translating among multiple representations (verbal, table, equation and graph). The research was carried out with 4 eighth grade students (3 girls, 1 boy). Case study which is a qualitative research design was used for the study. Data were collected through "Translating Among Multiple Representations Test (TAMRT)" and semi-structured interviews which were developed by researcher. Descriptive analysis method was used to analyze the data. The results of the data indicated that the most difficult translations were from verbal, table and equation representations to graph. The translations from verbal, equation and graph representations to table were the easiest translations for students. Additionally, findings suggest that the students' mistakes in translating table, equation and graph representations among verbal statement were stemming from lack of students' writing skills.

Key words: mathematics education, multiple representations

AŞKIN SAYILAR ŞADIRVANI

THE FOUNTAIN OF TRANSCENDENTAL NUMBERS

Tuğba HORZUM
Necmettin Erbakan Üniversitesi
thorzum@gmail.com

ÖZET: Bu çalışmada özellikle Konya (Alâeddin Camii, Karatay Medresesi, İnce Minareli Medrese, Aziziye Camii, Şerafettin Camii, Kapu Camii, İplikçi Camii, Selim Sultan Camii) ve Kırşehir (Melik Gazi Kümbeti, Ahi Evran Türbesi, Cacabey Camii ve Medresesi, Aşık Paşa Türbesi) illerinde Anadolu Selçuklu Devleti ile Osmanlı İmparatorluğu dönemlerinde inşa edilen ve günümüze kadar gelebilmiş mimari yapılar geometrik ve estetik açıdan incelenerek, bu iki mimarinin harmanlanmasıyla tasarlanan bir şadırvan üzerinde e ve π aşkın sayıları, farklı bir bakış açısıyla görselleştirilmiştir. Bu görselleştirmeyi yapabilmek için önce e ve π sayılarının ilk 2500 ondalık basamağındaki rakamlar Microsoft Excel programında 50x50'lik bir tabloya yerleştirilmiş, ardından 0'dan 9'a kadar tüm rakamlara bir renk atanmış ve tablonun her bir hücresi, hücreye karşılık gelen rakam yerine atanan renk ile renklendirilmiştir. Bu şekilde yapılan renkli Excel tablosu resim formatına dönüştürülmüştür. Son olarak tasarlanan şadırvan üzerinde gerekli ışıklandırmalar planlanarak bu renklendirmelerin akşam vaktinde gökyüzüne yansıtılarak e ve π sayılarına dikkat çekilmesi amaçlanmıştır.

Anahtar sözcükler: aşkın sayılar, e sayısı, π sayısı, matematik ve mimari, Osmanlı ve Selçuklu mimarisi

ABSTRACT: In this study, the transcendental numbers e and π were visualized on a fountain, which is designed via examining with a geometric and aesthetic viewpoint and blending the survived architectural structures of the Anatolian Seljuk Empire and the Ottoman Empire especially in Konya (Karatay/İnce Minareli Madrasa, Alaeddin/Aziziye/Serafettin/Kapu/İplikçi/Selim Sultan Mosque) and Kırşehir (Melik Gazi/Ahi/Aşık Pasha Tomb, Cacabey Mosque and Madrasa), with a different perspective. To make this visualization, the numbers of first 2500 decimal places of e and π were placed on the size of 50x50 table in Microsoft Excel. Then, all the numbers from 0 to 9 were assigned different colors and each cell of the table was colored with the corresponding assigned colors instead of numbers. The colored Excel table made in this way was converted into image format. Finally, it was intended to draw attention to the number e and π via planning the illumination on the designed fountain and reflecting these colors in the sky in the evening.

Keywords: transcendental numbers, the number e , the number π , mathematics and architecture, Seljuk and Ottoman architecture

MOODLE ÖĞRENME YÖNETİM SİSTEMİNİN KULLANILABİLİRLİĞİNİN İNCELENMESİ

Erhan ÜNAL
Afyon Kocatepe Üniversitesi
eunal@aku.edu.tr

Ahmet Murat UZUN
Afyon Kocatepe Üniversitesi
auzun@aku.edu.tr

ÖZET: Bu çalışmanın amacı, Öğrenme Yönetimi Sistemi olarak Moodle'un kullanılabilirliğini belirlemektir. Tarama yönteminin kullanıldığı çalışmaya, 2012-2013 öğretim yılında Afyon Kocatepe Üniversitesi Bilgisayar ve Öğretim Teknolojileri Eğitimi (BÖTE) Bölümü'nde öğrenim gören 137 öğretmen adayı katılmıştır. Çalışmada veri toplama aracı olarak, kişisel bilgi formu ve Kılıç-Çakmak, Güneş, Çiftçi ve Üstündağ (2011) tarafından geliştirilen “*Web Sitesi Kullanılabilirlik Ölçeği*” kullanılmıştır. Çalışma sonuçlarına göre Moodle'un kullanılabilirliğinin orta düzey olduğu çıkmıştır. Ayrıca kullanılabilirlik puanlarının cinsiyet ve sınıfa göre farklılaşmadığı bulunmuştur.

Anahtar Kelimeler: İnsan-bilgisayar etkileşimi, kullanılabilirlik, öğrenme yönetim sistemi

ABSTRACT: The purpose of this study was to explore the usability of Moodle as a learning management system. Survey method was used in this study. Data were gathered from 137 pre-service teachers studying at Computer Education and Instructional Technologies Department, Afyon Kocatepe University during 2012-2013 academic year. Personal Information Form and Web Site Usability Scale which was developed by Kılıç-Çakmak, Güneş, Çiftçi ve Üstündağ (2011) were used as data collection tool. The results of the study showed that the usability of Moodle was found at level of medium. On the other hand usability scores did not differ according to gender and classes.

Key Words: Human-computer interaction, usability, learning management system.

GİRİŞ

Bilgi ve iletişim teknolojilerinin eğitimde kullanılmasıyla, uzaktan eğitim, e-öğrenme, m-öğrenme, çevrimiçi öğrenme gibi birçok yeni kavramlar ortaya atılmıştır. Tüm bu öğrenme yollarının altında yatan temel yaklaşım, bilgi ve iletişim teknolojilerinin farklı özelliklerini kullanarak öğrencilerin öğrenmelerini kolaylaştırmak ve böylece etkili öğrenme ortamları oluşturmaktır. Artık e-öğrenme, uzaktan eğitim, çevrimiçi öğrenme, m-öğrenme birçok kurum tarafından yeni bilgilerin öğretiminde kullanılmaktadır.

Uzaktan eğitim, öğrenmenin farklı mekanlarda, çeşitli teknolojiler ve kurumsal organizasyonlarla gerçekleştiği planlı öğrenme ve öğretmedir (Moore ve Kearsley, 2012). Bir diğer tanımda ise, “uzaktan eğitim, öğrenci danışmanlığı, öğrenci başarısının gözetilmesi ve korunması ve öğrenilen materyalin gösterilmesinde, her biri sorumluluk alan öğretmenlerin oluşturduğu bir ekip tarafından yürütülen kendi kendine çalışma şeklinin sistematik olarak düzenlenmesidir.” (Kaya, 2005; s.11). Tanımlar incelendiğinde, öğrenci ve öğretmenin zaman ve mekandan bağımsız yapısı, öğrenme etkinliklerinin ve etkileşimin çeşitli bilgi ve iletişim teknolojileri ile gerçekleştiği bir öğretim yöntemi olduğu görülmektedir. Uzaktan eğitim farklı şekillerde sunulabilmektedir. Bunlardan en yaygını artık günümüzde bilgi ve iletişim teknolojilerinin kullanıldığı uzaktan eğitim türleridir.

Uzaktan eğitimde öğrenme gerçekleşirken üç farklı etkileşim meydana gelmektedir. Bunlar, öğrenci-içerik etkileşimi, öğrenci-öğretmen etkileşimi ve öğrenci-öğrenci etkileşimidir (Moore, 1989). Bu etkileşim türleri dikkate alındığında uzaktan eğitim etkileşiminde öğrencinin önemli olduğu görülmektedir (Oral, 2011). Öğrencinin bu etkileşim ortamında başarılı olması için sistemin iyi yapılandırılması gerekmektedir. Bu nedenle uzaktan eğitimde öğretimin tasarımı ve yönetimi önemlidir.

Öğrenme Yönetim Sistemleri

Günümüzde uzaktan eğitim yapılırken, derslerin yönetimi, öğrenenin yönetimi, içeriğin hazırlanması ve sunumu, değerlendirme gibi geleneksel öğrenme ortamlarında gerçekleştirilen her türlü öğrenme-öğretme etkinlikleri için öğrenme yönetim sistemi (Learning Management System) denilen yazılımlar kullanılmaktadır. Öğrenme yönetim sistemleri, öğrenme ile ilgili tüm etkinliklerin yönetimini sağlayan yazılımlardır. Öğrenme yönetim sistemi öğrenim sürecini planlamayı, değerlendirmeyi, uygulamayı sağlayan bir yazılımlardır (Aydın ve Biroğul, 2008). Öğrenme yönetim sisteminin, derslerin yönetimi, içeriğin sunumu, ödev verme ve notlandırma, sınav uygulama, öğrencileri yönetme, öğrenci kayıtlarını tutma gibi birçok özelliği vardır (Paulsen, 2002).

Öğrenme yönetim sistemleri açık kaynak kodlu ve ticari sistemler şeklinde ikiye ayrılır. Açık kaynak kodlu öğrenme yönetim sistemlerine Moodle, aTutor, Dokeos, OLAT, Sakai, eFront, Claroline örnek verilebilir (Özarlan, 2008). Açık kaynak kodlu öğrenme yönetim sistemlerinin en çok kullanılanı şüphesiz Moodle (Modular-Object-Oriented-Dynamic-Learning-Environment-Esnek Nesne Yönelimli Dinamik Öğrenme Ortamı) gelmektedir. Moodle ücretsiz olarak dağıtılan, birçok sistemle entegre bir şekilde çalışabilen açık kaynak kodlu öğrenme yönetim sistemidir. Diğer öğrenme yönetim sistemleri gibi Moodle üzerinde ders materyalleri paylaşılabilen, ödevler, quizler, sınavlar yapılabilmekte, forum, wiki, anket gibi özellikleri kullanılabilmektedir (Moodle, 2013).

Kullanılabilirlik

International Standarts Organization (1994), kullanılabilirlik kavramını, bir ürünün, belirli bir kullanım bağlamında, belirli kullanıcılar tarafından, belirli amaçları gerçekleştirmek üzere, etkin (effective), verimli (efficient) ve tatmin edici (satisfactory) bir biçimde kullanılabilmesi olarak tanımlamıştır (Gürses, 2006; s. 15). Nielsen'e (2012) göre kullanılabilirlik, kullanıcının etkileşimde bulunduğu arayüzlerin kullanımının ne kadar kolay kullanılabildiğini belirleyen özelliktir. Ayrıca kullanılabilirlik kelimesi, tasarım sürecinde kullanım kolaylığı sağlamak için yöntemler olarak da kullanılır. Kullanılabilirlik 5 bileşeni olan bir özelliktir. Bu bileşenler şunlardır (Nielsen, 2012):

- Öğrenilebilirlik: Kullanıcının etkileşimde bulunduğu arayüzlerle karşılaştığında temel görevleri ilk girişiminde başarabilmesi ile ilgilidir.
- Etkililik: Kullanıcının etkileşimde bulunduğu arayüzleri öğrendikten sonra görevleri ne kadar hızlı yapabildiği ile ilgilidir.
- Hatırlanabilirlik: Kullanıcı etkileşimde bulunduğu arayüzleri bir süre kullanmadığında, yeniden arayüz karşısında yeterliğini kolayca göstermesiyle ilgilidir.
- Hata: Kullanıcının etkileşimde bulunduğu arayüzlerde ne kadar hata yaptığı, bu hataların kaçının ciddi hatalar olduğu, bu hataları kolaylıkla nasıl düzeltilebileceği ile ilgilidir.
- Memnuniyet: Kullanıcının etkileşimde bulunduğu arayüzlerin kullanımından ne kadar memnun olduğu ile ilgilidir.

Kullanılabilirlik, kullanıcı, çevre ve görevler gibi faktörleri içeren kullanım bağlamı ile de doğrudan ilişkilidir. Arayüz kalitesinin ve kullanılabilirliğin sağlanmasında, sistemin hedef kullanıcı kitlesinin iyi analiz edilmesi ve tasarımların kullanıcı beklentileriyle uyumlu olması gerekmektedir. Norman (1988), bir sistemin ancak kullanıcısının onunla ne yapacağını kolayca anlayabildiği ölçüde kullanılabilir olduğunu vurgulamaktadır. Literatürdeki kullanılabilirlik tanımlarının geneli etkililik, hata toleransı, memnuniyet, verimlilik gibi özellikler üzerinde durmaktadır. Kullanılabilirlik, kullanılabilirlik testleri, inceleme yöntemleri ve sorgulama yöntemleri ile ölçülebilmektedir (Gürses, 2006).

İlgili Araştırmalar

Alanyazın incelendiğinde Moodle'un kullanılabilirliği ile ilgili olarak Kakasevski, Mihajlov, Arsenovski ve Chungurski (2008), Moodle'un modüllerinin kullanılabilirliğini incelemişlerdir. Bu amaçla 84 öğrenci kullanılabilirlik anketi doldurmuşlar, modüllerle ilgili çeşitli görevler yerine getirmişlerdir. Ayrıca uzmanlar da modülleri değerlendirmişlerdir. Araştırma sonuçlarına göre, Moodle'un genel olarak kullanılabilirliği iyi olarak bulunmuştur. Kullanılabilirliğin alt faktörlerine bakıldığında kullanıcıların ortalama puanları hatırlanabilirlik, memnuniyet, kullanım kolaylığı, etkililik ve verimlilik olarak sıralanmaktadır.

Martin, Martínez, Revilla, Aguilar, Santos ve Boticario (2008), Moodle, Sakai ve dotLRN öğrenme yönetim sistemlerinin kullanılabilirliklerini karşılaştırmışlardır. Bu amaçla, kullanılabilirlik alanında uzman 5 kişi bu üç platformu belirlenen görevleri gerçekleştirerek değerlendirmişlerdir. Araştırma sonuçlarına göre, en yüksek kullanılabilirlik puanını dotLRN daha sonra Sakai ve en düşük puanı da Moodle almıştır.

Kirner, Custódio ve Kirner (2008), yaptıkları çalışmada hazırladıkları değerlendirme modeli ile Moodle'un kullanılabilirliğini değerlendirmişlerdir. Bu amaçla Moodle'u kullanan 39 öğretmen, sezgisellik, işlevsellik, verimlilik, öğrenilebilirlik, etkililik ve memnuniyet boyutlarında Moodle'u değerlendirmişlerdir. Araştırma sonuçlarına göre Moodle'un genel olarak ve tüm alt boyutlarda memnun edici kullanılabilirliği olduğu bulunmuştur.

Çevik (2010), Bilgisayar ve Öğretim Teknolojileri Öğretmenliği Bölümü'nde (BÖTE) öğrenim gören öğretmen adaylarının Moodle'u kullanırken karşılaştıkları zorlukları ve Moodle'un içerdiği uygulama kategorilerinin gerekli olup olmadığına ilişkin öğrenci görüşlerini belirlemiştir. Bu amaçla, araştırmacı tarafından geliştirilen, Kullanıcı İşlemleri, Ders Ekranı, Ders Menüsü, Bloglar alt bölümlerinden oluşan anket 111 öğretmen adayına uygulanmıştır. Araştırma sonuçlarına göre, Moodle'un kullanılabilirliği kolay olarak bulunmuştur. Ayrıca Moodle'daki uygulama kategorilerinin (Kullanıcı İşlemleri, Ders Ekranı, Ders Menüsü, Bloglar), tüm öğretmen adayları tarafından gerekli olduğu belirlenmiştir.

Tüm bu tartışılan literatür ve yapılan araştırmalara göre kullanılabilirlik değerlendirmesinde farklı yöntemler uygulandığı ve farklı sonuçlar alındığı görülmektedir. Bu nedenle bu çalışmanın problemini, öğrenme yönetimi sistemi olarak Moodle'un kullanılabilirliğini belirlemek oluşturmaktadır.

Çalışmanın Amacı

Bu çalışmanın amacı öğrenme yönetimi sistemi Moodle'un kullanılabilirliğinin incelenmesidir. Bu amaçla aşağıdaki sorulara cevap aranmıştır:

1. Kullanıcıların öğrenme yönetimi sistemi Moodle'un kullanılabilirliğine ilişkin görüşleri nedir?
2. Kullanıcıların öğrenme yönetimi sistemi Moodle'un kullanılabilirliğine ilişkin görüşleri
 - a. Cinsiyete,
 - b. Sınıfagöre farklılaşmakta mıdır?

YÖNTEM

Araştırmada nicel araştırma yöntemlerinden tarama modeli kullanılmıştır. Bilindiği gibi tarama modelinde var olan bir durum olduğu gibi betimlenmeye çalışılır. Genel tarama modeli, çok sayıda elemandan oluşan bir evrende, evren hakkında genel bir yargıya varmak amacı ile evrenin tümü ya da ondan alınacak bir grup örnek ya da örneklem üzerinde yapılan tarama düzenlemeleridir (Karasar, 2005).

Çalışma Grubu

Araştırmanın çalışma grubunu 2012-2013 öğretim yılında Afyon Kocatepe Üniversitesi BÖTE Bölümü'nde öğrenim gören ve Moodle üzerinden ders alan 137 öğretmen adayı oluşturmaktadır. Bu öğretmen adayları Moodle'u takip ettikleri derslere ulaşmakta, dersler ilgili haftalık ödevlerini yapmakta ve buraya yüklemekte, dersle ilgili öğrenme nesnelerini takip etmekte, dersle ilgili duyurulara erişmekte, sınavları uygulamakta kullanılmaktadırlar. Araştırmaya katılan öğretmen adaylarının sınıf ve cinsiyetlerine ilişkin istatistikler Tablo 1'de verilmiştir.

Tablo 10: Katılımcılara ait istatistikler

Sınıf	Kız		Erkek		Toplam	
	f	%	f	%	f	%
2	22	16.1	26	19.0	48	35.0
3	24	17.5	25	18.2	49	35.8
4	19	13.9	21	15.3	40	29.2
Toplam	65	47.4	72	52.6	137	100

Veri Toplama Aracı

Araştırmada veri toplama aracı olarak, kişisel bilgi formu ve Kılıç-Çakmak, Güneş, Çiftçi ve Üstündağ (2011) tarafından geliştirilen "Web Sitesi Kullanılabilirlik Ölçeği" kullanılmıştır. Ölçeğin tercih edilmesindeki amaç, geçerlik ve güvenilirlik analizlerinin bir öğrenme yönetim sisteminin kullanılabilirliğinin belirlenmesinde yapılmasıdır. Web sitelerinin kullanılabilirliğini belirlemeye yönelik geliştirilen "Web Sitesi Kullanılabilirlik Ölçeği" 25 maddeden oluşmaktadır. Ölçek, maddelerine verilecek cevaplar likert tipi beşli derecelendirme

ölçeği ile toplanmaktadır. Ölçek, “Kesinlikle katılıyorum (5)”, “Katılıyorum (4)”, “Kararsızım (3)”, “Katılmıyorum (2)” ve “Kesinlikle katılmıyorum (1)” seçeneklerinden oluşmaktadır. Ölçekteki maddelerin 21’i olumlu 4’ü ise olumsuz maddedir. Ölçekten alınacak en düşük puan 25, en yüksek puan ise 125’tir. Ölçekten alınacak yüksek puan, web sitesinin kullanılabilirliğinin yüksek olduğunu göstermektedir.

BULGULAR

Öğretmen adaylarının *Web Sitesi Kullanılabilirlik Ölçeği’nden* aldıkları puanlara ilişkin aritmetik ortalama ve standart sapma değerleri Tablo 2’de verilmiştir.

Tablo 11: Kullanılabilirlik puanlarının dağılımı

Değişken	N	X	SS
Gezinme Kolaylığı	137	35.03	6.73
Tasarım Erişim Kolaylığı	137	24.90	5.41
Kullanım Kolaylığı	137	13.45	3.32
Kullanılabilirlik	137	11.38	2.99
	137	84.77	13.21

Tablo 2 incelendiğinde Moodle’un genel olarak kullanılabilirliğinin “Orta” olduğu bulunmuştur. Ölçeğin alt boyutları olan Gezinme Kolaylığı, Tasarım, Erişim Kolaylığı, Kullanım Kolaylığı boyutlarında da “Orta” olduğu bulunmuştur. Bu bulguya göre öğretmen adaylarının Moodle öğrenme yönetim sisteminin kullanılabilirliğini orta düzey olarak görmektedirler.

Ayrıca ölçeğe verilen cevaplar analiz edilerek, Moodle’un kullanılabilirliğine ilişkin olumlu ve olumsuz yönleri bulunmuştur. Ortalama puanı 3’ten yüksek olanlar olumlu, düşük olanlar olumsuz olarak değerlendirilmiştir. Moodle’un kullanılabilirliğine ilişkin en olumlu yanları, maddeler, boyut ve ortalama puanları ile birlikte aşağıda verilmiştir.

- Sitede rahatlıkla geziniyorum (Tasarım boyutu $X=3.69$).
- Arkaplan rengi okumayı kolaylaştırıyor (Tasarım boyutu $X=3.69$).
- Sitede, site haritası, gezinme çubuğu, önceki ve sonraki sayfaya geçiş gibi gezinmeye yardımcı araçlar bulunmaktadır. (Gezinme kolaylığı boyutu $X=3.67$).
- Arkaplan-metin renk uyumu okumayı kolaylaştırıyor (Tasarım boyutu $X=3.67$).

Moodle’un kullanılabilirliğine ilişkin olumsuz yanları, maddeler, boyut ve ortalama puanları ile birlikte aşağıda verilmiştir.

- Siteyi kullanırken teknik desteğe ihtiyaç duyuyorum (Kullanım kolaylığı boyutu, $X=2.56$).
- Sitenin kullanımını öğrenmek çok zaman alıyor (Kullanım kolaylığı boyutu, $X=2.69$).
- Siteyi karmaşık buluyorum (Kullanım kolaylığı boyutu, $X=2.86$).

Öğretmen adaylarının *Web Sitesi Kullanılabilirlik Ölçeği’nden* aldıkları puanların cinsiyete göre anlamlı bir şekilde farklılaşp farklılaşmadığına Bağımsız Örneklem için t-Testi ile bakılmıştır. Analiz sonuçları Tablo 3’te verilmiştir.

Tablo 12: Kullanılabilirlik puanlarının cinsiyete göre t-Testi sonuçları

Değişken	Cinsiyet	X	SS	sd	t	p
Gezinme Kolaylığı	Kız	35.44	6.54	135	.672	.503
	Erkek	34.66	6.91			
Tasarım Erişim Kolaylığı	Kız	25.14	4.99	135	.481	.632
	Erkek	24.70	5.79			
Kullanım Kolaylığı	Kız	14.00	2.65	135	1.911	.580
	Erkek	12.94	3.77			
Kullanılabilirlik	Kız	11.42	2.95	135	.167	.867
	Erkek	11.34	3.05			

Kullanılabilirlik	Kız	86.02	11.83	135	1.047	.297
	Erkek	83.65	14.34			

Tablo 3 incelendiğinde kullanılabilirlik puanlarının ve alt boyutlarının cinsiyete göre anlamlı bir farklılık göstermediği bulunmuştur ($p>.05$).

Öğretmen adaylarının *Web Sitesi Kullanılabilirlik Ölçeği*'nden aldıkları puanların sınıfa göre anlamlı bir şekilde farklılaşp farklılaşmadığına Tek Yönlü Varyans (ANOVA) analizi ile bakılmıştır. Analiz sonuçları Tablo 4'te verilmiştir.

Tablo 13: Kullanılabilirlik puanlarının sınıfa göre ANOVA sonuçları

Değişken	X	SS	X	SS	X	SS	F (2,134)	p
Gezinme Kolaylığı	35.73	7.97	33.96	6.37	35.51	5.43	.974	.38
Tasarım	25.06	5.36	24.36	6.03	25.40	4.70	.431	.65
Erişim Kolaylığı	13.09	3.32	13.82	3.36	13.44	3.32	.582	.56
Kullanım Kolaylığı	11.33	2.88	11.52	3.08	11.28	3.10	.083	.92
Kullanılabilirlik	85.21	15.73	83.66	12.35	85.63	10.96	.280	.75

Tablo 4 incelendiğinde kullanılabilirlik puanlarının ve alt boyutlarının sınıfa göre anlamlı bir farklılık göstermediği bulunmuştur ($p>.05$).

SONUÇ VE ÖNERİLER

Uzaktan eğitimde bilgi ve iletişim teknolojilerinin kullanımının artması beraberinde kullanılan bu teknolojilerin öğrenenlerin memnuniyetini karşılamasını getirmiştir. Bu nedenle kullanılan yazılımların, sitelerin, öğrenme yönetim sistemlerinin etkili, verimli ve işlevsel olması gerekmektedir (Kılıç-Çakmak, Güneş, Çiftçi ve Üstündağ, 2011).

Bu araştırmada uzaktan eğitimde kullanılan öğrenme yönetim sistemi Moodle'un kullanılabilirliği araştırılmıştır. Araştırma sonucunda Moodle'un kullanılabilirliğinin orta düzey olduğu bulunmuştur. Bu bulguya göre, Moodle'un arayüz kullanımı orta düzeyde kullanılabilirliğini göstermektedir. Bir diğer taraftan Moodle'un tasarımının, gezinme, erişim ve kullanım kolaylıklarının kullanıcılar tarafından orta düzeyde kullanılabilir olduğu ifade edilebilir. Literatürde de Moodle'un kullanılabilirliğine yönelik olumlu sonuçların bulunduğu benzer çalışmalar vardır (Arsenovski ve Chungurski, 2008; Çevik, 2010; Kirner, Custódio ve Kirner, 2008). Ayrıca Moodle'un kullanılabilirliği cinsiyet ve sınıf değişkenlerine göre farklılaşmamaktadır. Kullanılabilirlik, doğrudan kullanıcının etkileşimde bulunduğu arayüzlerin kullanım memnuniyeti ile ilgilidir. Dolayısıyla olduğundan Moodle'un kullanılabilirliğinin cinsiyete ve sınıfa göre fark bulunamamıştır.

Gelecekteki çalışmalarda öğrenme yönetim sistemlerinin kullanılabilirliği ile ilgili benzer çalışmalar yürütülebilir. Nicel çalışmaların yanı sıra nitel ve karma çalışmalar yürütülebilir. Kullanılabilirliğin kullanılabilirlik testleri, inceleme ve sorgulama gibi farklı tekniklerle (Gürses, 2006) ölçülmektedir. Bu çalışmada kullanılabilirlik testi tekniği kullanılmıştır. Buna ek olarak, inceleme ve sorgulama teknikleri kullanılarak farklı çalışmalar tasarlanabilir.

KAYNAKLAR

- Aydın, C. C. ve Biroğul, S. (2008). E-Öğrenmede açık kaynak kodlu öğretim yönetim sistemleri ve Moodle. *Bilişim Teknolojileri Dergisi*, 1(2), 31-36.
- Çevik A., (2010). Moodle öğrenme yönetim sisteminin kullanılabilirliğine yönelik öğrenci görüşleri. 4. *International Computer and Instructional Technologies Symposium*, 25 Eylül 2010, Türkiye (Konya),
- Gürses, E., A. (2006). *Kütüphane web sitelerinde kullanılabilirlik ve kullanılabilirlik ilkelerine dayalı tasarım*. Yayımlanmamış doktora tezi, Hacettepe Üniversitesi Sosyal Bilimler Enstitüsü, Ankara.

- Kakasevski, G., Mihajlov, M., Arsenovski, S. ve Chungurski, S. (2008). Evaluating usability in learning management system Moodle. *30th International Conference on Information Technology Interfaces, 23-26 June 2008 (s.613-618)*, Cavtat/Dubrovnik, Croatia.
- Karasar, N. (2005). *Bilimsel Araştırma Yöntemi*. 15. Baskı. Ankara: Nobel Yayın Dağıtım.
- Kaya, Z. (2005). *Uzaktan eğitim*. Ankara: PegemA Yayıncılık,
- Kılıç Çakmak, E., Güneş, E., Çiftçi, S. ve Üstündağ, M. T. (2011). Web sitesi kullanılabilirlik ölçeğinin geliştirilmesi: Geçerlilik, güvenilirlik analizi ve uygulama sonuçları. *Pegem Journal Of Education and Instruction, 1(2)*, 31-40.
- Kirner, T. G., Custódio, C. D. A., ve Kirner, C. (2008). Usability evaluation of the moodle system from the teachers' perspective. *IADIS International Conference eLearning, 22-25 July, 2008(s.371-378)*, Amsterdam, Netherlands.
- Martin, L, Martínez, D. R., Revilla, O., Aguilar, M.J., Santos O. C. ve Boticario J. G., (2008). *Usability in e-Learning Platforms: Heuristics Comparison between Moodle, Sakai and dotLRN. 7th European Conference on e-Learning (ECEL), 6-7 November 2008*. Agia Napa, Cyprus.
- Moodle (2013). http://docs.moodle.org/26/en/About_Moodle adresinden 12 Mart 2013 tarihinde erişilmiştir.
- Moore, M. G., & Kearsley, G. (2012). *Distance education: A systems view of online learning*. USA: Wadsworth-Cengage Learning.
- Moore, M. G. (1989). Editorial: Three types of interaction. *American Journal of Distance Education, 3(2)*, 1-6.
- Nielsen, J. (2012). Usability 101: Introduction to Usability. <http://www.useit.com/alertbox/20030825.html> adresinden 13 Mart 2012 tarihinde erişilmiştir.
- Oral, B. (2011). Uzaktan eğitim. Özcan Demirel ve Eralp Altun (Ed.) içinde *Öğretim teknolojileri ve materyal tasarımı (5. baskı)* içinde (ss. 171-205). Ankara: PegemA Yayınları.
- Özarlan, Y. (2008). Uzaktan eğitim uygulamaları için açık kaynak kodlu öğrenme yönetim sistemleri. *XIII. Internet in Turkey Conference 22-23 Aralık 2008(s.55-60)*. Orta Doğu Teknik Üniversitesi: Ankara, Turkey.

2005 VE 2013 FEN BİLGİSİ ÖĞRETİM PROGRAMLARININ 4. VE 5. SINIF DÜZEYLERİNİN BİLİMSEL SÜREÇ BECERİLERİ AÇISINDAN KARŞILAŞTIRILMASI

THE COMPARISON OF 2005 AND 2013 SCIENCE CURRICULA FOR SCIENCE PROCESS SKILLS IN 4TH AND 5TH GRADES

Yakup SABAN
Afyon Kocatepe Üniversitesi, Y.L. Öğrencisi
yakupsaban@hotmail.com.tr

Bülent AYDOĞDU
Afyon Kocatepe Üniversitesi, Eğitim Fakültesi
baydogdu1976@yahoo.com.tr

Rıdvan ELMAS
Afyon Kocatepe Üniversitesi, Eğitim Fakültesi
relmas@aku.edu.tr

ÖZET: İki öğretim programı temel ilkeler, içerik, hedefler, öğrenme-öğretme süreci ve değerlendirme olmak üzere beş boyutta bilimsel süreç becerileri (BSB) açısından karşılaştırılmıştır. Araştırmada nitel araştırma yaklaşımlarından doküman incelemesi ve içerik analizi yöntemleri kullanılmıştır. Çalışmanın sonuçlarına göre temel ilkeler boyutunda her iki öğretim programında da BSB'ye yer verildiği; içerik boyutunda ise her iki öğretim programında da BSB'nin diğer öğrenme alanları ile örüntülü bir şekilde ele alındığı; hedefler boyutunda sadece Fen ve Teknoloji dersi öğretim programında BSB kazanımlarının sınıflandırılarak verildiği ve bazı bilgi kazanımlarıyla eşleştirildiği Fen Bilimleri dersi öğretim programında ise böyle bir durumla karşılaşılmadığı; ancak öğrenme-öğretme sürecinde Fen ve Teknoloji dersi öğretim programında bazı etkinlik örneklerinin BSB kazanımlarıyla eşleştirilse de Fen Bilimleri dersi öğretim programında böyle bir uygulamayla karşılaşılmadığı; değerlendirme boyutunda ise her iki öğretim programında BSB'ye doğrudan yapılan bir atıfla karşılaşılmadığı görülmüştür. Her iki öğretim programında verilen etkinlik örnekleri ve kazanımlardaki BSB vurgularından BSB'nin ihmal edilmediği ama özellikle güncellenen programda BSB vurgusunun daha müphem olduğu sonucuna varılmıştır.

Anahtar sözcükler: Bilimsel Süreç Becerileri, Fen Programı, Öğretim Programı

ABSTRACT: A content analysis was made for both curricula in terms of core principles, content, aims, teaching and learning processes, and evaluation for science process skills. Both curricula emphasized reaching the goal of possessing science process skills for all elementary students in their visions. In addition both curricula were interweaved science process skills with other learning domains. In Science and Technology curriculum (2005), mentioned science process skills were also matched with the sample activities in the curriculum document. Science process skills were not emphasized in the evaluation parts of the both curricula. Both curricula highlighted science process skills but the stress was vague in the updated science curriculum (2013).

Key words: Science Process Skills, Science Curriculum, Curriculum

LİSANSÜSTÜ ÖĞRENCİLERİNİN YENİ FEN BİLİMLERİ ÖĞRETİM PROGRAMINA İLİŞKİN GÖRÜŞLERİ

POSTGRADUATE STUDENTS' OPINIONS ON NEW SCIENCE CURRICULUM

Hakan Şevki AYVACI

Karadeniz Teknik Üniversitesi, Fatih Eğitim Fakültesi
hsa@ktu.edu.tr

Sinan BÜLBÜL

Karadeniz Teknik Üniversitesi, Fatih Eğitim Fakültesi
sinanbulbul@ktu.edu.tr

Dilek ÖZBEK

Karadeniz Teknik Üniversitesi, Fatih Eğitim Fakültesi
dilekcozbek@ktu.edu.tr

Mehmet YILDIZ

Karadeniz Teknik Üniversitesi, Fatih Eğitim Fakültesi
mhmt.yildiz@yahoo.com

ÖZET: Bu çalışmayla 2013-2014 Eğitim-Öğretim yılında kademeli olarak uygulamaya konulan Fen Bilimleri Dersi Öğretim Programına yönelik lisansüstü öğrencilerinin görüşlerini ortaya çıkarmak amaçlanmıştır. Araştırma, doğası gereği nitel bir çalışma olup, özel durum çalışması yöntemi kullanılmıştır. Nitel araştırmalarda, örnekleme derinlemesine araştırabilmek için örneklem grubu küçük seçilmesi gerektiğinden bu çalışmada amaçlı örnekleme yöntemi tercih edilmiştir. Araştırmanın verileri, lisansüstü öğrenim görmekte olan 5 akademisyen ile yapılan yarı yapılandırılmış mülakatlardan elde edilmiştir. Mülakatlardan elde edilen verilerin analizinde betimsel analiz kullanılmıştır. Araştırma sonunda, katılımcıların yeni Fen Bilimleri Dersi Öğretim Programı'na ilişkin görüşleri incelendiğinde yeni programda kazanımların azaltıldığı, öğretmenin bu programda daha rahat olduğu, öğretim strateji ve yöntemlerine programda fazla yer verilmediği, programın felsefesinin tam olarak ifade edilmediği, öğrencilerin girişimciliğine yönelik ifadelerin yer aldığı ancak onları araştırma sorgulamaya yönlendirmede eksikliklerin olduğu sonucuna ulaşılmıştır. Bu sonuçların aksine lisansüstü öğrencilerinin çoğu yeni öğretim programını daha uygulanabilir bulmuştur.

Anahtar sözcükler: fen bilimleri dersi, öğretim programı, lisansüstü öğrencilerinin görüşleri.

ABSTRACT: This study aims to reveal the opinions of postgraduate students on Science Curriculum which is going to be put in into practice in 2013-2104 school year. This is a qualitative work by the nature of research and case study method is used. Since it is necessary to select a small sample group to be able to do the research profoundly, purposeful sampling is preferred. The data of the research is collected from the semi-structured interviews which are made with 5 academicians. Descriptive analysis is used to evaluate the data from the interviews. When the participants' opinions on the new science curriculum are examined, it is concluded in the passage that the gains are lessened; the teacher is more comfortable with this program, teaching strategies and methods are not given place, the philosophy of the program is not mentioned precisely, there are some expressions about entrepreneurship of the students but there is a lack of orientation for the students. On the contrary to this results, the majority of the graduate students found the new teaching program more applicable.

Key words: science lesson, teaching program, opinions of graduate students.

GİRİŞ

Bireylerin, ülkenin eğitim amaçları kapsamında istenilen düzeye gelebilmeleri için öğretim programları geliştirilmektedir (Demirbaş, 2008). Fakat bu program geliştirme çalışmaları, hızla gelişen bilim ve teknolojiyen, toplumsal alandaki gereksinimlerden etkilenmektedir (Gömleksiz, 2007). Bu değişimlerden etkilenen öğretim programlarından biri de fen öğretim programıdır.

Günümüzde eğitim yenilik hareketlerine liderlik eden temaların başında program geliştirme gelmektedir. Dünyadaki birçok program geliştirme çalışmasında öğretme ve öğrenme içeriği tekrar kontrol edilmekle kalmayıp, aynı zamanda öğretim programı teknik bir araç ve süreç olarak algılanmaktadır (Lönnqvist, Horn & Berkta, 2005). Öğretim programlarının gelişimi de hiç bitmeyen bir süreçtir. Bu süreç “planlama, geliştirme, tartışma, uygulama, değerlendirme ve eğitim ortamlarında veya gerçek hayatta öğrenmeyi kolaylaştırmaya dayanan mekanizma ve uygulamaları gözden geçirme” basamaklarından oluşan karmaşık bir döngüyü içermektedir (Crisan, 1993).

Ülkelerin gelişmesinde önemli bir yer tutan fen bilimleri eğitiminin kalitesini arttırmak için sarf edilen çabalar genelde, müfredat programlarını iyileştirme ve bu programların etkinliğini sağlayacak okul ortamları geliştirme üzerine yoğunlaşmaktadır (Ayas, 1995). Eğitim sistemlerine işlerlik kazandıran en önemli unsurun öğretim programları olduğu (Erden, 1998) düşünüldüğünde, dinamik bir yapıya bürünmüş eğitim sistemleriyle uyumlu dinamik öğretim programlarının gerekliliği de kaçınılmazdır. 2004 yılında köklü bir değişimle geliştirilen Fen ve Teknoloji Dersi Öğretim Programı, yapılandırmacı yaklaşıma dayanan, öğrenci merkezli bir programdı. Fen ve teknoloji okur-yazarı olarak yetişen bireyler, bilgiye ulaşmada ve kullanmada, problem çözmede, fen ve teknoloji ile ilgili sorunlar hakkında muhtemel riskleri, faydaları ve mevcut seçenekleri dikkate alarak karar verebilecek ve yeni bilgi üretmede daha etkin olacaktı (TTKB, 2006). Bununla birlikte öğretim programlarının uygulama boyutu ya da içerik yapısı gibi unsurlarından kaynaklanan sorunlar, öğrencilerin fen ve teknoloji okuryazarı olarak yetişmesinin önünde engel olmaktadır (Hobson, 2001). Vizyonda belirtilen fen okur-yazarı birey yetiştirme, 2013-2014 Eğitim-Öğretim yılında uygulamaya konacak olan İlköğretim Kurumları Fen Bilimleri Dersi Öğretim Programı'nın da vizyonunun temelini oluşturmaktadır. Uygulamaya konacak olan yeni programda kazanım sayıları, öğrenme-öğretme stratejileri, bireylere girişimcilik ve kariyer bilinci aşılama gibi konular kapsamında yenilikler getirilmiştir.

Roehrig, Kruse ve Kern. (2007), çalışmasında 27 kimya öğretmeniyle birlikte yürüttüğü çalışmada, öğretmenlerin bilgi ve inançlarıyla okul karakteristiğinin yürürlüğe giren yeniliğe dayalı kimya öğretim programının uygulanmasına olan etkisini incelemeyi amaçlamıştır. Mülakatlar sonucunda elde edilen verilere göre öğretmenlerin genel olarak programdan memnun oldukları ama programın nasıl uygulanması gerektiği konusunda yalnız kaldıkları belirlenmiştir. Gömleksiz (2007) yaptığı çalışmada 2004 yılında uygulamaya konan programın pilot olarak uygulandığı okullarda görev yapan öğretmenlerle, programın uygulanmasına ve etkililiğine ilişkin görüşlerini çeşitli değişkenler açısından incelemiş; programın uygulamada en önemli sorunların öğrenci mevcutlarının fazla olduğunu ve sahip olunan fiziki donanımların yetersiz kaldığını tespit etmiştir. Ayrıca sunulan rehberlik hizmetleri açısından da sıkıntı yaşanıldığı belirlenmiştir. Bununla birlikte öğretmenlerin programa dayalı eğitim ortamında çeşitli sorunlar yaşadıklarını da tespit etmişlerdir. Güneş, Dilek, Hoplan ve Güneş (2011)'in 2004 yılı İlköğretim Fen ve Teknoloji programını, içerik ve uygulama açısından öğretmen görüşlerine göre değerlendirdiği çalışmada; öğretmenlerin dersin deneylerle yürütülmesi düşüncelerine rağmen laboratuvarı nadiren kullandıklarını, ders süresinin yetersiz olmasından dolayı konuları yetiştiremediklerini, programın içeriğinin fazla olduğunu ve öğretmenlerin geleneksel öğretim yöntem ve tekniklerinin dışına çıkmadıklarını belirlemişlerdir. Ayrıca öğretmenlerin 2004 yılı Fen ve Teknoloji dersi öğretim programından pek memnun olmadıklarını da sonucuna ulaşmışlardır. Tüysüz ve Aydın (2009), 312 fen ve teknoloji öğretmenin programaya yönelik görüşlerini likert tipi bir ölçekle belirledikleri çalışma sonucunda, programın bazı avantajlarının yanı sıra kalabalık sınıflarda uygulanmasının oldukça zor olduğu ifade edilmiştir.

Yapılan çalışmalara genel olarak bakıldığında, 2004 yılında yürürlüğe giren programın uygulanma aşamasına yönelik görüşleri ve karşılaşılan zorlukları ortaya çıkarmaya yönelik olduğu görülmektedir. Yapılan bu çalışmada ise belirtilen çalışmalardan farklı olarak veriler, programın uygulanmasına başlamadan önce toplanmıştır. Buradaki amaç, 2013-2014 Eğitim-Öğretim yılında uygulamaya girecek olan yeni programa yönelik, uygulama öncesi bakış açılarını, sorun oluşturabilecek konuları, öğretim programlarından beklentileri ortaya çıkarmak ve ileride yapılacak olan program değerlendirme çalışmalarına içerik kaynağı oluşturmaktır. Bu amaç kapsamında lisansüstü öğrencilerinin görüşlerinin alınmasına gerek duyulmuştur

YÖNTEM

Çalışmada Fen Bilimleri dersi öğretim programına ilişkin akademisyen görüşlerini belirlemek amaçlandığından, özel durum çalışması yöntemi kullanılmıştır. Özel durum çalışması, adından da anlaşılacağı üzere özel bir durum üzerine yoğunlaşmayı sağlayarak kısa sürede araştırılmasına imkân verdiğinden, özellikle bireysel yürütülen çalışmalar için uygundur. Bu tür çalışmalarda genelleme amacı olmamasına rağmen, çalışmanın sonuçları genele ışık tutabilir (Çepni, 2012).

Katılımcılar

Şekil 1’de lisansüstü öğrencilerinin YFBÖP’na ilişkin görüşlerinin tema ve kodları verilmiştir. Katılımcıların YFBÖP’na içeriğine yönelik görüşlerini ifade ettikleri, olumlu ve olumsuz yönlerini belirttikleri ve ilk tema olan YFBÖP içeriği toplam 16 koddan oluşmaktadır. İkinci tema ise programın uygulanabilirliğidir. Bu temada katılımcıların 2013-2014 eğitim-öğretim yılında uygulamaya konulan olan YFBÖP’nın uygulanabilirliği irdelenmiştir. Bu temada bütün katılımcıların YFBÖP’nın uygulanabilir olduğunu belirttikleri görülmektedir. Son tema ise, katılımcıların belirttikleri düşünceler doğrultusunda hangi programı tercih edeceklerine yönelik olup program tercihi başlığında ifade edilmiştir

YFBÖP’nin içerik temasına ait bulgulara bakıldığında katılımcıların olumlu ve olumsuz görüşlere sahip olduğu görülmektedir. Katılımcıların içerik bağlamında olumlu görüşleri “*kazanımların sadeliği, öğretmen ve öğrencilerin serbestliği, araştıran-sorgulayan bireylerin olması, öğrenci seviyesine uygunluk, girişimcilik, sosyo-bilimsel konuların ve bilimin doğasının varlığı*” şeklindedir. Olumsuz görüşlere ait kodlar ise “*basitleştirilmiş içerik, konuların azlığı, geleneksel yaklaşım, konu listesi şeklinde olması, öğrenilenlerin tekrarı niteliği, öğretim stratejilerinin eksikliği*” şeklindedir. Bu bağlamda bazı katılımcıların görüşlerine aşağıda yer verilmiştir:

*K₁: Öğretme ve öğrenme stratejilerine baktığım zaman daha çok eskiye dönüş yani **geleneksel yaklaşıma dönüş** olduğunu fark ediyorum. **Öğretmenin rolü artırılmış.** Öğrencinin yükü hafifletilmiş.*

*K₂:**Kazanım sayılarında büyük oranda bir azalma** olmuş. Belki de bu programın en önemli değişikliklerinden birisi de FTTÇ alanında yapılmıştır. Özellikle **girişimcilik** var. Ondan sonra **bilimin doğası** var. **Sosyo-bilimsel konular** var.*

Katılımcıların yeni programın uygulanabilirlik temasına ait kodları incelendiğinde, hepsinin programın uygulanabilirliği hakkında olumlu görüşe sahip olduğu görülmektedir. Ancak katılımcılardan her biri, farklı sebeplerden dolayı “*programın kullanılabilirliği, öğretmen merkezli yaklaşımı benimsemiş olması, eski programın özeti niteliğinde olması, verimli olamayacağı düşüncesi ve öğretmenlerin mesleki deneyiminin önemi bağlı olması*” şeklinde görüşlerini belirtmiştir. Aşağıda bazı katılımcıların programın uygulanabilirliğine ait görüşleri yer almaktadır.

*K₂: Onun için genel itibariyle yeni neslin özellikle mesleki deneyimi **5 yılı 10 yılı geçmeyen öğretmenlerin** bu programı rahatlıkla uygulayabileceğini ama özellikle kıdem yılı 15in üzerinde olan öğretmenlerin uygulayabileceğini pek zannetmiyorum.*

*K₁: Yeni öğretim programı bence eski programa göre **daha kullanışlı. Uygulanabilirliğinin yüksek** olduğunu düşünüyorum.*

Son olarak, katılımcılardan yaptığı bütün yorumlara göre, eski ve yeni program arasından hangisini tercih edeceği sorulmuştur. Bu bağlamda 3 katılımcı yeni öğretim programını tercih ederken 2 katılımcı eski öğretim programını tercih etmektedir. Yeni öğretim programını tercih eden katılımcılar bunun sebebini, *kazanımların azlığı, sürenin yeterli ve etkin kullanılabilmesi, öğrenme kolaylığı, sınıfa hâkimiyetin kolaylığı, öğretmenin rahat hareket edebilmesi, öğrencilerde girişimciliğin ön plana çıkarılmış olması ve öğrencileri proje geliştirmeye yönlendiriyor olması* şeklinde açıklamıştır. Eski programı tercih eden katılımcılar ise tercih sebeplerini; *öğrenci merkezli olması, öğretmene rehber olması, uygulanabilirliğinin daha yüksek olması ve öğrencileri araştırmaya yönlendiriyor olması* şeklinde açıklamıştır. Bu bağlamda bazı katılımcıların eski ve yeni öğretim programı hakkındaki yorumlarına aşağıda yer verilmiştir:

*K₂: Şimdiden **proje geliştirmeye, girişimci olmaya** yöneltilen öğrencilerin ileride problemlere daha rahat çözüm bulacağını düşünüyorum. Bu yüzden yeni programı tercih ederim.*

*K₃: Bir önceki (2004 yılı) olamı tercih ederim. Eğer bizi ileriye götürecek, **alternatif düşünebilen, kritik edebilen, fen-teknoloji icat edebilen, yeni bir şey ortaya koyabilen, yapılanı kopyalamayan, girişimci olan, aklı başında gençler yetiştirmek** istiyorsak bunun programı bu değil bence.*

SONUÇ

Çalışmada YFBÖP’nin içeriğine yönelik sonuçlar incelendiğinde, bu programın, basitleştirilmiş içeriğe, eski öğretim programı ile aynı felsefeye sahip olduğuna, programın içeriğinin konu listesi şeklinde yer aldığına, öğretim stratejileri bağlamında eksiklikler olduğuna, öğretmen ve öğrencinin bu programa göre daha esnek davranabilme fırsatı tanıdığına, programda yer alan konuların birleştirilerek azaltıldığına, bu konuların öğrenci seviyesine uygun olduğuna, öğrencileri araştırma-sorgulamaya ve girişimciliğe yönlendirme konusunda çabaların yer aldığına ilişkin sonuçlara ulaşılmıştır. Ayrıca bu programda yer alan konuların sosyo-bilimsel konular ve bilimin doğasına yönelik konular olduğu ifade edilmiştir. Benzer şekilde Gömleksiz (2007)’nin 2004 yılında kabul edilen öğretim programı hakkında öğretmenlerin görüşlerini alarak yürüttüğü çalışmasında, öğretim programında öğrencilerin bireysel farklılıklarının dikkate alındığı bulgusu belirlenmiştir. Burada

Gömlüksüz, programın özelliklerinden ziyade, öğretmenlerin programa yönelik inançlarının olumlu olması ve programı en iyi şekilde uygulayabilmesinin daha önemli olduğunu ifade etmiştir. Roehrig vd. (2007) 'nin kimya öğretmenleriyle yürüttüğü çalışmada öğretim programının öğretmenlere liderlik etmesi ve programı nasıl uygulayacaklarını göstermesi gerektiğini belirtmiştir. Katılımcıların YFBÖP'nin öğretmene rehberlik etmediğini düşündükleri belirlenmiştir.

Ayrıca katılımcıların bir kısmı yeni öğretim programını uygulanabilirliğine ait olumlu görüşlere sahipken bazıları ise yeni programın, eski öğretim programının özeti şeklinde olduğunu düşünmektedir. Bu bağlamda katılımcılar öğretim programının uygulanabilirliği paralelinde program tercihlerini ifade etmişlerdir. Benzer şekilde Gömlüksüz (2007)'nin çalışmasında yeni programın etkili biçimde uygulanması ve istenilen verimin alınması öğretmenlerin programı tanımalarına, benimsemelerine bağlı olduğu görülmektedir.

Sonuç olarak lisansüstü öğrencilerinin YFBÖP'ye ilişkin görüşleri incelendiğinde yeni programda kazanımların azaltıldığı, öğretmenin bu programda daha rahat olacağına inanıldığı, öğretim strateji ve yöntemlerine programda fazla yer verilmediği, programın felsefesinin tam olarak ifade edilmediği, öğrencilerin girişimciliğine yönelik ifadelerin yer aldığı ancak onları araştırma sorgulamaya yönlendirmede eksikliklerin olabileceği konusunda bulgulara ulaşılmıştır. Ancak çalışmaya katılan lisansüstü öğrencilerinin tamamı yeni öğretim programını daha uygulanabilir bulmuştur.

ÖNERİLER

Lisansüstü öğrencilerinin yeni fen bilimleri öğretim programına ilişkin görüşlerinin belirlendiği bu çalışma beş katılımcıyla yürütülmüştür. Bu bağlamda katılımcı sayısının artırılarak görüşlerde oluşabilecek muhtemel farklılıklar daha derinlemesine irdelenmelidir. Ayrıca farklı demografik değişkenler ve çalışma gruplarıyla benzer çalışmalar yürütülmelidir. Program uygulama sürecine girdikten sonra, programla daha çok muhatap olan öğretmenler, öğrenciler, idareciler ve velilerin görüşlerini belirlemeye yönelik çalışmalar yürütülmelidir.

KAYNAKLAR

- Ayas, A. (1995). Fen bilimlerinde program geliştirme ve uygulama teknikleri üzerine bir çalışma: iki çağdaş yaklaşımın değerlendirilmesi. *Hacettepe Üniversitesi Eğitim Fakültesi Dergisi*, 11, 149-155.
- Crisan, A. (1993). Curriculum Reform in Romania. In J. Van Bruggen (Ed.) Case Studies: Strategies for and organization of curriculum development in some European countries. Paper presented at the UNESCO conference, Bucharest, 1-5 June 1992. Enschede: CIDREE – SLO, (155-166).
- Çepni, S. (2012). *Araştırma ve proje çalışmalarına giriş*. (4. Baskı), Trabzon: Celepler Matbaacılık.
- Demirbaş, M. (2008). 6. Sınıf Fen Bilgisi ve Fen ve Teknoloji Öğretim Programlarının Karşılaştırılmalı Olarak İncelenmesi: Öğretim Öncesi Görüşler. *Uludağ Üniversitesi Eğitim Fakültesi Dergisi*, 21(2), 313-338.
- Erden, M. (1998). *Eğitimde program değerlendirme* (3. Baskı). Ankara: Anı Yayıncılık.
- Gömlüksüz, M.N. (2007). Yeni İlköğretim Programına İlişkin Öğretmen Görüşlerinin Çeşitli Değişkenler Açısından Değerlendirilmesi. *Eurasian Journal of Educational Research*, 27, 69-82.
- Güneş, T., Dilek, N.Ş., Hoplan, M. & Güneş, O. (2011). Fen ve teknoloji dersinin öğretmenler tarafından uygulanması üzerine bir araştırma. 2nd International Conference on New Trends in Education and Their Implications 27-29 April, Antalya-Turkey.
- Hobson, A. (2001). Teaching Relevant Science For Scientific Literacy: Adding Cultural Context to The Sciences. *Journal of College Science Teaching*, 30(4), 238-243.
- Lönnqvist, A., Horn, R. & Berktaç, N. (2005). Curriculum Reform and Implementation in The 21st Century: Policies, Perspective and Implementation, edited by Pasi Sahlberg, Selected Conference Papers, 5.
- Miles, M.& Huberman, M. (1994). *Qualitative data analysis: an expanded sourcebook*. (2th Edition), America: Person Education.
- Roehrig, G. H., Kruse, R. A. ve Kern, A. (2007). Teacher and school characteristics and their influence on curriculum implementation. *Journal of Research in Science Teaching*, 44, 883-907.
- Strauss, A.L. & Corbin, J. (1990). *Basics of qualitative research: Grounded theory procedures and techniques*. Newbury Park, CA: Sage.
- TTKB (Talim ve Terbiye Kurulu Başkanlığı), (2006). *İlköğretim Fen ve Teknoloji Dersi Öğretim Programları ve Kılavuzu*. Ankara: Devlet Kitapları Müdürlüğü.
- Tüysüz, C.& Aydın, H. (2009). İlköğretim fen ve teknoloji dersi öğretmenlerinin yeni fen ve teknoloji programına yönelik görüşleri. *Gazi Eğitim Fakültesi Dergisi*, 29(1), 37-54.
- Yüksel, S. (2002). Yükseköğretimde eğitim-öğretim faaliyetleri ve örtük program. *Uludağ Üniversitesi Eğitim Fakültesi Dergisi*, 15(1), 361-370.

İLKÖĞRETİM 5. SINIF FEN BİLİMLERİ DERS KİTABI İÇERİĞİNE ELEŞTİREL BAKIŞ

CRITICAL ANALYSIS OF 5TH GRADE SCIENCE EDUCATION TEXTBOOK

Sinan ERTEN
Hacettepe Üniversitesi
serten@hacettepe.edu.tr

Ceylan ŞEN
Bozok Üniversitesi
cylnsen@gmail.com

Ahmet Volkan YÜZÜAK
Bartın Üniversitesi
ahmetvolkanyuzuak@gmail.com

ÖZET: Bu araştırmanın amacı; 2013 öğretim yılından itibaren uygulamaya konulan fen bilimleri dersi 3. 4. 5. 6. 7. ve 8. sınıf öğretim programına göre, 2013-2014 öğretim yılında hazırlanan 5.sınıf Fen Bilimleri ders kitabına ilişkin öğretmen görüşlerini belirlemektir. Araştırmanın çalışma grubunu Aydın, Zonguldak, Bartın, Kayseri ve Konya’da görev yapmakta olan 22 adet Fen Bilgisi öğretmeni oluşturmaktadır. Araştırmanın verileri için açık uçlu sorulardan oluşan yapılandırılmış bir görüşme formu kullanılmıştır. Araştırma sonuçlarına göre, çalışmaya katılan öğretmenlerin çoğu kitabın kazanımlarla uyumlu olduğunu ve görsel tasarımın öğrenci seviyesine uygun olduğunu düşünmektedir.

Anahtar sözcükler: ilköğretim, fen bilgisi eğitimi, konu alanı ders kitabı incelemesi

ABSTRACT: Aim of the present study was to determine teachers’ opinions about 5th grade science textbook which is based on 3. 4. 5. 6. 7. 8. grade science curriculum. The participants of the study were twenty two science teachers who work in Aydın, Zonguldak, Bartın, Kayseri and Konya. Interview form which included open-ended questions was used to collect data. The result of the study reveals that most of the participants think the course book is consistent with outcomes and visual design of the book is appropriate to the student level.

Key words: elementary education, science education, subject area textbook review

8. SINIF ÖĞRENCİLERİNİN GEOMETRİK CİSİM İLE İLGİLİ KAVRAM İMGELERİ

8TH GRADE STUDENTS' CONCEPT IMAGES OF SOLIDS

Ayşe Simge ERGİN
Milli Eğitim Bakanlığı
asmge@hotmail.com

Elif TÜRNÜKLÜ
Dokuz Eylül Üniversitesi
elif.turnuklu@deu.edu.tr

ÖZET: Matematikte kavramlar ve kavramlara ait tanımlar kavramın öğrenilmesinde önemli rol oynar. Tanımlar bireyler tarafından birbirlerinden farklı olarak kurulabilir, bu da bireyin kavram hakkındaki kişisel düşüncelerini ve deneyimlerini veya kavram imgelerini yansıtmaya daha yakındır. Burada kavram imgesi bir kavramla ilgili bilişsel yapının tamamını içerir. Bu durum da öğrencilerinin geometrik kavramlara ilişkin öğrenmelerinin nasıl gerçekleştiği hakkında bilgi verebilir.

Bu araştırmada 8. Sınıf öğrencilerinin geometrik cisimlere ilişkin kavram imgelerinin neler olduğunu ortaya çıkarmak amaçlanmıştır. Amaçlı örnekleme yöntemi ile 5 farklı ortaokuldan farklı başarı düzeylerine göre belirlenen 20 öğrenciyle yarı yapılandırılmış görüşme yapılmıştır. Görüşme, geometrik cisimleri tanımlatan sorular ve görsel olarak tanımayı içeren sorulardan oluşmaktadır. Araştırmada elde edilen verilerin analizinde içerik analiz tekniği kullanılmıştır. Bu yöntemle elde edilen veriler belirlenen temalar çerçevesinde analiz edilmiş olup frekansları sunulmuştur.

Elde edilen bulgulara göre öğrencilerin formal tanımlardan çok uzak oldukları, prizma ve piramitlerde yüzey özelliklerinin imgelerde ön plana çıktığı bulunmuştur. Bazı öğrencilerin ise çevredeki nesnelere kullanarak tarif ettikleri tespit edilmiştir. Ayrıca cisimlerde öğrencilerin kavram imgelerine yön veren aşırı genellemelere sebep olan yanlışlar da bulunmuştur. Sonuç olarak cisimlerin öğretiminde yol gösterici ipuçlarına ulaşılmıştır.

Anahtar sözcükler: geometrik cisimler, kavram imgesi, geometri öğretimi

ABSTRACT: In mathematics, concepts and concept definitions play an important role in learning. Definitions can be established different by individuals. This is close to reflect their personal thought and experience about the concept or concept image. Here, the meaning of the concept image is that includes all the cognitive structure about it. So, this can give information about how children learn geometric concepts.

The purpose of this study was to investigate 8th students' concept images of solids. It was conducted with 20 students chosen by purposive sampling method. These students who were different academic levels, attending 5 different schools. The data were collected by semi-structured interview. During the interviews, the students were asked about definition of solids and visual recognition of them. The collected data were analyzed by content analysis. Based on the content analysis, the themes that each participant used, were determined and then presented in frequencies.

From the findings were determined that participants were far from the formal definition. Properties of solids' surface had been found to come forward in the image of prisms and pyramids. Some participants described the solids by using everyday objects. In addition, misconceptions lead to over generalization and giving direction to image had been also found. As a result, some teaching implications about solids were raised.

Key words: Solids, concept image, teaching geometry

TEACHER VIEWS ON STUDENTS' MISTAKES AND MISCONCEPTIONS: EQUATION EXAMPLE

Doç. Dr. Ramazan GÜRBÜZ
Adıyaman Üniversitesi

Zeynep ÇAVUŞ ERDEM
MEB

ABSTRACT: The aim of this study is to examine the opinions of teachers on students' misconceptions and mistakes about equation. For this purpose, semi-structured interviews related to the causes of errors and mistakes in equations and removing those were conducted with six teachers who work in six different middle schools in a city. Descriptive analysis technique was used to analyze the interviews. After the analyses, it has been determined that teachers associate students' mistakes and misconceptions with teaching methods, lack of time and the students' faulty learning and that they tried to have students memorize the solutions of math problems, instead of focusing on the cognitive structure constituting the source of the problems.

Key words: Mathematics teaching, Teacher, Equation, Error, Misconception.

ON DAILY MATHEMATICS: MATHEMATICS COMING FROM MINUS INFINITE

Zühal GÜN
Adıyaman Üniversitesi
gunzahal@hotmail.com

Ebru KÜKEY
Fırat Üniversitesi
ebrukey@hotmail.com

ABSTRACT: The aim of this study is to reveal the way used the people who aren't studying mathematics to solve the mathematical problems encountered in daily life. The study is a case study used in qualitative research. The study group consisted of 4 adults who never went to school and 4 students who went first grade primary school. Data was collected through unstructured interviews. Content analysis was used to analyze the data. The results observed that the adult individuals solved the math problems encountered in daily life by one to one matching, trial and error, taking any number as reference, grouping etc. Also it was seen that children of primary school age solved problems by grouping and matching. It is suggested that the practical methods resulting from research should be added to the primary and secondary school mathematics curriculum and then different thinking techniques should be gained for students in math.

Key words: Daily mathematics, mathematics education.

DYSLEXIA AND DIFFICULTIES IN MATHEMATICS

Goran NEDOVIĆ,

Ivana SRETENOVIĆ

Dyslexia is a permanent disorder of written language, specifically in acquiring reading and writing, and computing. Children with dyslexia have difficulty in decoding and understanding the symbols of written language, and in the mathematics this is transferred to the numerical symbols, mathematical operations with symbols and understanding of mathematical language.

This paper presents examples of difficulties in mathematics that children with dyslexia may have. Because of the difficulty in reading and understanding the instructions and tasks presented with words, the child often does not solve the problem or can not learn a new concept, as it is not able to read instructions from a collection of tasks. The next difficulty is reflected in the poor understanding of mathematical vocabulary. In fact, many children with dyslexia have poor vocabulary of general terms and it is difficult to master specific mathematical vocabulary. Then, there are difficulties in adopting the concept of numbers and relationships among numbers and difficulties in the use of number sequence, difficulty in remembering and automation and reproduction of all types of numerical sequences, difficulty in learning, in memory and in reproduction of arithmetic tables, rotation, inversion, omission and addition of digits in numbers, and the difficulties in adopting the visual appearance of individual symbols. Procedural errors in simple arithmetic are consequence of the difficulties in learning, memory and reproduction sequence of procedures in the algorithms.

Difficulties which in mathematics have children with dyslexia can be removed by using custom methods. When a student has a good teacher who knows mathematics, methods of work and the nature of the child's difficulties, problems begin to slowly disappear.

Keywords: mathematics, learning difficulties, dyslexia, methods of work

6. SINIF MATEMATİK DERSİNDE PROBLEME DAYALI ÖĞRENME YAKLAŞIMININ MATEMATİĞE İLİŞKİN TUTUMA ETKİSİ

THE EFFECTS OF PROBLEM BASED LEARNING TECHNIQUE ON SIXTH GRADE STUDENTS' ATTITUDES TOWARD MATHEMATICS COURSE

Gülcan UYAR¹

Konya İhsan Özkaşıkçı İlkokulu
gulcan257@hotmail.com

Ayten Pınar BAL
Çukurova Üniversitesi
apinar@cu.edu.tr

ÖZET: Bu çalışma, 6. sınıf matematik dersinde probleme dayalı öğrenme yaklaşımının matematiğe ilişkin tutuma etkisini ortaya çıkartmak amacıyla yapılmıştır. Araştırmanın çalışma grubunu Düzce ili İsmetpaşa İlköğretim okuluna devam eden 79 altıncı sınıf öğrencisi oluşturmuştur. Araştırma, ön test-son test kontrol gruplu deneme modelinde tasarlanmıştır. Veri toplama aracı olarak “Matematiğe Yönelik Tutum Ölçeği” uygulanmıştır. Araştırmada tutum ölçeğinden elde edilen veriler kovaryans analizi ile sınanmış ve anlamlılık düzeyi $p < .05$ olarak alınmıştır. Araştırma sonunda elde edilen verilere göre, tutum ölçeği son test puanları açısından deney grubu lehine anlamlı bir fark bulunmuştur. Bu bağlamda, probleme dayalı öğrenme tekniğinin matematiğe yönelik olumlu tutum geliştirmeye fayda sağladığı sonucuna ulaşılmıştır.

Anahtar sözcükler: matematik öğretimi, matematiğe yönelik tutum, probleme dayalı öğrenme

ABSTRACT: This study aims to find out how problem based learning approach effects on the attitudes of sixth grade mathematics students. The study has been conducted in İsmetpaşa Primary school in the district of Düzce with 79 students. The courses have been taught by the researcher both in experimental and control group. “Mathematics Attitude Scale” developed by Baykul (1990) have been administered at the beginning of the study as pre-test, at the end of the study as post-test to both experimental and control groups. Covariance analysis has been conducted on the data obtained from the attitude scale. The level of significance has been taken $p < .05$. Regarding the findings obtained from the “Mathematics Attitude Scale”, there has been a significant difference among the groups in favour of the experimental group. Students stated that they found the courses more interesting and different, so they loved the course. They performed enduring learning with the real life stories and they were more motivated to be involved in the courses. They also added that this technique has enabled them to communicate well with their friends and to help each other.

Key words: mathematics education, mathematics attitudes, problem based leaning

GİRİŞ

Matematik, yapı ve bağıntılar yoluyla genellemelere ulaşan soyut bir kavramdır. Bu bağlamda, soyut kavramların kazanılmasının zor olması ve sınıf içi etkinliklerde matematiksel problemlere yönelik öğrencilerin aktif bir tutum sergileyememeleri matematiğe karşı olumsuz tutumlara neden olmaktadır. Ancak, özellikle son yıllarda yapılandırmacı öğrenme yaklaşımları ile birlikte öğretmen odaklı klasik öğrenme süreçleri yerini aktif katılımın sağlandığı, bilgiyi elde etme ve bilgiyi kullanma becerilerinin önem kazandığı, sürece odaklı bir matematik eğitimi anlayışına bırakmıştır. Ülkemizde, 2005 ilköğretim matematik öğretim programında, öğrencilerin bireysel farklılıklarına, ilgilerine ve ihtiyaçlarına cevap vermeyi amaçlayan yöntem ve tekniklerle aktif öğrenme yaşantılarının hazırlanması gerekliliği vurgulanmaktadır (MEB, 2009). Bu kapsamda, yapılandırmacı yaklaşımın alt dallarından birisi olan Probleme Dayalı Öğrenme (PDÖ) yaklaşımları büyük önem taşımaktadır. Probleme dayalı öğrenme öğrenci merkezli ve etkin öğrenmeyi geliştiren öğretimsel bir yöntemdir. Problemin çözümü ya da anlaşılması yoluyla uygulama sürecinden sonuç çıkaran bir öğrenmedir. Probleme dayalı öğrenme modeli öğrencilerde sorumluluk duygusunu artırırken matematiğe karşı olumlu tutumların oluşmasını da öncülük eder (CIDR, 2004).

¹ Bu çalışma Gülcan Uyar'ın yüksek lisans tezinden üretilmiştir.

İlgili literatür incelendiğinde yapılan çalışmaların genelde probleme dayalı öğrenme yaklaşımı ile akademik başarı değişkeni arasındaki bağı odaklandığı görülmektedir. (Akın, 2006; Ayvaci, 2011; Elshafei, 1999; Eski, 2011; Günhan, 2006; Polanco, Calderon ve Delgado, 2004; Özdi, 2011; Özgen, 2007; Özgen ve Pesen, 2008; Uslu, 2006; Usta, 2013). Ancak, tutuma yönelik olarak ise sınırlı sayıda çalışma göze çarpmaktadır (Günhan, 2006; Özgen, 2007; Özdi, 2011). Bu kapsamda, Günhan (2006) araştırmasında Probleme Dayalı Öğrenme yönteminin 7. sınıf öğrencilerinin matematiğe yönelik tutumları ve akademik başarıları üzerindeki etkilerini incelemiştir. Deneysel olarak tasarlanan araştırmanın sonunda, Günhan, probleme dayalı öğrenme yaklaşımının öğrencilerde matematiğe yönelik olumlu tutumlar oluşturduğunu ve akademik başarılarını arttırdığını ortaya çıkarmıştır. Benzer şekilde Özgen (2007) de yaptığı çalışmada probleme dayalı öğrenme yaklaşımlarının öğrencilerin akademik başarıları, matematik dersine yönelik tutumları ve hatırd tutma düzeyleri üzerindeki etkisini incelemiştir. Araştırmanın sonucunda; probleme dayalı öğrenme yaklaşımının, öğrencilerin; akademik başarı düzeylerini arttırdığı, matematik dersine yönelik tutum düzeylerinin yükseldiği bulgusuna ulaşılmıştır.

Yukarıdaki bilgilerden de açıkça görüldüğü gibi, probleme dayalı öğrenme yaklaşımı ile ilgili yapılan çalışmaların genelde akademik başarı değişkeni üzerine odaklandığı ve tutuma yönelik çalışmaların ise sınırlı düzeyde olduğu görülmektedir. Bu olgudan yola çıkarak bu çalışma ile 6. sınıf matematik dersinde probleme dayalı öğrenme yaklaşımının matematiğe ilişkin tutuma etkisi irdelenmeye çalışılmıştır.

YÖNTEM

Bu araştırma ön test-son test kontrol gruplu yarı deneysel modele göre tasarlanmıştır. Deney grubunda probleme dayalı öğrenme yöntemi, kontrol grubunda ise mevcut yöntem kullanılmıştır. Araştırmanın çalışma evrenini Düzce ilinde bulunan altıncı sınıf öğrencileri oluşturmaktadır. Çalışma grubunu ise aynı bölgede bulunan İsmet Paşa İlköğretim Okulu altıncı sınıf öğrencileri oluşturmaktadır. Bu grupların çalışma grupları olarak alınmasında; kişisel bağımsız değişkenlerden olan cinsiyet ve anne-baba öğrenim düzeyinin bu sınıflarda homojen olarak bulunması etkili olmuştur. Uygulama yapılan ilköğretim okulunun altıncı sınıfından iki derslikte okuyan 79 öğrenci, deney (39) ve kontrol (40) gruplarını oluşturmuştur.

Veri toplama aracı olarak Baykul'un (1990) geliştirdiği "Matematik Tutum Ölçeği" öğrencilerin matematiğe ilişkin tutumlarını ölçmede kullanılmıştır. Yapılan faktör analizi sonuçlarına göre, tek faktörle açıklanabilen ölçeğin varyans oranı 0,56 olarak bulunmuştur.

Verilerin analizinde öğrencilerin tutum ölçeği öntest puanlarına göre düzeltilmiş sontest ortalama puanları arasında farklılaşma olup olmadığı gerekli ön varsayımlar sağlandıktan sonra kovaryans analizi ile test edilmiştir.

BULGULAR

Araştırmada probleme dayalı öğrenme yaklaşımının uygulandığı deney grubu ile mevcut öğretimin uygulandığı kontrol grubundaki öğrencilerin, matematiğe yönelik tutumları ön puanları kontrol altına alındığında, son puanları arasında deney grubu lehine anlamlı bir farklılık olup olmadığına ilişkin bulgular bölümde yer almaktadır. Buna göre deney ve kontrol gruplarında yer alan öğrencilerin matematiğe yönelik tutum ölçeğinden aldıkları ön puan ve son puanlarına ilişkin aritmetik ortalama, standart sapma değerleri, son test düzeltilmiş ortalama puanları ile standart hata değerleri Tablo 1'de verilmiştir.

Tablo 1. Deney ve Kontrol Gruplarında Yer Alan Öğrencilerin Matematik Dersine Yönelik Tutum Ölçeğinden Aldıkları Ön Puan ve Son Puanların Ortalamaları, Düzeltilmiş Ortalamaları ve Standart Hata Değerleri

Gruplar	N		Toplam Puanlar		Düzeltilmiş Son test Ortalamaları	
			\bar{X}	SS	\bar{X}_d	SH
Deney	39	Öntest	81.33	9.04	92.05	1.30
		Sontest	92.16	7.24		
Kontrol	40	Öntest	80.28	8.38	81.52	1.24
		Sontest	81.43	8.44		

Tablo 1 incelendiğinde, matematik dersine ilişkin tutum ölçeği son puanlarının ön puanlarına göre deney ve kontrol gruplarında yükseldiği görülmektedir. Düzeltilmiş son ortalama puanları deney grubunun 92.05, kontrol grubunun ise 81.52'dir. Gözlenen bu farkın anlamlı olup olmadığını test etmek için kovaryans analizi uygulanmış, elde edilen sonuçlar Tablo 2'de verilmiştir.

Tablo 2. Deney ve Kontrol Gruplarında Yer Alan Öğrencilerin Matematik Dersine İlişkin Tutum Ölçeği Son Puanlarının Kovaryans Analizi Sonuçları

Varyansın Kaynağı	Kareler Toplamı	Sd	Kareler Ortalaması	F	p
Kontrol Edilen Değişken (Öntest)	102.379	1	102.379	1.66	.201
Gruplama Ana Etkisi	2112.644	1	1056.322	34.28	.000
Hata	4560.423	74	61.627		
TOPLAM	6878.701	77			

Tablo 2 incelendiğinde görüldüğü gibi, kovaryans analizi sonuçları ön puanları kontrol altına alındığında, son düzeltilmiş ortalama puanları açısından gruplama ana etkisinin anlamlı bir farkın olduğu bulunmuştur ($F(1,74)=34.28$; $p<.01$). Matematiğe yönelik tutum ölçeğinden elde edilen bulgular, son puanlar açısından deney grubu lehine anlamlı bir fark olduğunu göstermektedir.

TARTIŞMA, SONUÇ VE ÖNERİLER

Probleme dayalı öğrenme yönteminin altıncı sınıf öğrencilerinin matematiğe yönelik tutuma etkisini belirlemek amacıyla, deney ve kontrol gruplarının ön tutum - son tutum toplam puanları üzerinde istatistiksel işlem olarak kovaryans analizinden yararlanılmıştır. Yapılan kovaryans analizi sonuçları ön puanları kontrol altına alındığında, son düzeltilmiş ortalama puanları açısından gruplama ana etkisinin anlamlı bir farkın olduğu bulunmuştur. Matematiğe yönelik tutum ölçeğinden elde edilen bulgular, son puanlar açısından deney grubu lehine anlamlı bir fark olduğunu göstermektedir. Araştırmadan elde edilen bu sonuç, literatürdeki diğer çalışma bulgularıyla da paralellik göstermektedir (Aka, 2012; Biber, 2012; Gülcan, 2006; Karataş, 2008; Özdil, 2011; Özgen, 2007; Uslu, 2006; Usta, 2013).

Günhan (2006) probleme dayalı öğrenmenin öğrencilerin matematiğe yönelik tutumlarına etkisini incelediği çalışmanın sonucunda, bu yöntemin öğrencilerin matematiğe yönelik tutumlarını olumlu yönde arttırdığını ortaya koymuştur. Özgen de (2007) yaptığı araştırmanın sonucunda; matematik eğitiminde probleme dayalı öğrenme yaklaşımının, öğrencilerin; matematik dersine yönelik tutum düzeylerini yükselttiği sonucuna ulaşmıştır. Hmelo-Silver (2004) probleme dayalı öğrenme stratejisi kullanarak yaptıkları çalışmalarında yöntemin içsel motivasyonları yüksek tutmayı arttıracak yönde etki sağladığını söylemektedirler.

Bu çalışmada, probleme dayalı öğrenme tekniğinin matematik dersine yönelik tutuma olan etkisi incelenmiştir. Yapılacak benzer çalışmalarla da bu yöntemin farklı duyuşsal özellikler (hatırda tutma, demokratik tutumlar, matematik kaygısı vb.) üzerinde etkili olup olmadığı araştırılabilir.

KAYNAKLAR

- Aka, E. (2012). *Asitler ve bazlar konusunun öğretiminde kullanılan probleme dayalı öğrenme yönteminin farklı değişkenler üzerine etkisi ve yönteme ilişkin öğrenci görüşleri*. Yayımlanmış doktora tezi, Gazi Üniversitesi, Ankara.
- Akın, P. (2009). *İlköğretim 5. Sınıf Matematik Dersi İçin Probleme Dayalı Öğrenme Yönteminin Öğrenci Başarısına Etkisi*. Yayımlanmış yüksek lisans tezi, Dokuz Eylül Üniversitesi, İzmir.
- Ayvacı, A. (2011). *Probleme Dayalı Öğrenme Yaklaşımının Denklem Kavramının Öğretiminde Etkisi*. Yayımlanmış yüksek lisans tezi, Kastamonu Üniversitesi, Kastamonu.
- Baykul, Y. (1990). *İlkokul beşinci sınıftan lise ve dengi okulların son sınıflarına kadar matematik ve fen derslerine karşı tutumda görülen değişmeler ve öğrenci yerleştirme sınavındaki başarı ve ilişkili olduğu düşünülen bazı faktörler*. Ankara: ÖSYM Yayınları.
- Biber, M. (2012). *Duyuşsal Özelliklerin Probleme Dayalı Öğrenme Sürecinde Öğrencilerin Matematiksel Kazanımlarına Etkisi*. Yayımlanmış doktora tezi, Dokuz Eylül Üniversitesi, İzmir.
- CIDR, 2004. Problem-Based Learning Center for Instructional Development and Research, Vol. 7, No. 3. Retrieved September 10, 2011, from <http://www.depts.washington.edu/cidweb/TeachingBulletin.html>.
- Elsfahei, D. (1999). A Comparison of problem based and traditional learning in algebra II. *Dissertation Abstract Index*, 60(01) 225A.

- Eski, M. (2011). *İlköğretim 7. sınıflarda cebirsel ifadeler ve denklemlerin öğretiminde probleme dayalı öğrenmenin etkisi*. Yayınlanmış yüksek lisans tezi, Kastamonu Üniversitesi, Kastamonu.
- Günhan, B. C. (2006). *İlköğretim II. kademedeki matematik dersinde probleme dayalı öğrenmenin uygulanabilirliği üzerine bir araştırma*. Yayınlanmış doktora tezi, Dokuz Eylül Üniversitesi, İzmir.
- Hmelo-Silver, C.E. (2004). Problem based learning: what and how do students learn?, *Educational Psychology Review*, 16(39), 235-263.
- Karataş, İ. (2008). *Problem Çözmeye Dayalı Öğrenme Ortamının Bilişsel ve Duyuşsal Öğrenmeye Etkisi*. Yayınlanmış doktora tezi, Karadeniz Teknik Üniversitesi, Trabzon.
- MEB (2009). *İlköğretim Matematik Dersi 6-8. Sınıflar Öğretim Programı ve Klavuzu*. Ankara: Talim ve Terbiye Kurulu Başkanlığı.
- Özgül, G. (2011). Probleme dayalı öğrenme yaklaşımının ilköğretim 7. sınıflarda çevre ve alan kavramında öğrenci başarısına etkisi. Yayınlanmış yüksek lisans tezi, Kastamonu Üniversitesi, Kastamonu.
- Özgen, K. ve Pesen C. (2008). Probleme Dayalı Öğrenme Yaklaşımı ve Öğrencilerin Matematiğe Yönelik Tutumları. *D. Ü. Ziya Gökalp Eğitim Fakültesi Dergisi*, 11, 69-83
- Özgen, K. (2007). *Matematik dersinde probleme dayalı öğrenme yaklaşımının öğrenme ürünlerine etkileri*. Yayınlanmış yüksek lisans tezi, Dicle Üniversitesi, Diyarbakır.
- Polanco, R., Calderon, P., Delgado, F. (2004). Effects of a problem-based learning program on engineering students' academic achievements in a Mexican university. *Innovations in Education and Teaching International*, 41(2).
- Üslü, G. (2006). *Ortaöğretim matematik dersinde probleme dayalı öğrenmenin öğrencilerin derse ilişkin tutumlarına, akademik başarılarına ve kalıcılık düzeylerine etkisi*. Yayınlanmış yüksek lisans tezi, Balıkesir Üniversitesi, Balıkesir.
- Usta, N. (2013). Probleme dayalı öğrenmenin ortaokul öğrencilerinin matematik başarısına, matematik öz yeterliğine ve problem çözme becerilerine etkisi. Yayınlanmış doktora tezi, Gazi Üniversitesi, Ankara.

8. SINIF ÖĞRENCİLERİNİN PERSPEKTİF ÇİZİMLER KONUSUNU ÖĞRENMELERİNE WEBQUEST UYGULAMASININ ETKİSİ

THE EFFECT OF WEBQUEST APPLICATION ON 8TH GRADE STUDENTS 'LEARNING PERSPECTIVE DRAWING

Aytaç KURTULUŞ
Eskişehir Osmangazi Üniversitesi, Eğitim Fakültesi
agunaydi@ogu.edu.tr

Kerem ÇOBAN
Eskişehir Osmangazi Üniversitesi, Eğitim Bilimleri Enstitüsü
Kerem.cobam@hotmail.com

ÖZET: İçinde yaşadığımız dünya 3 boyutlu iken görüntüleme ekranı ise 2 boyutlu bir düzlemdir. Üç boyutlu nesnelerin, iki boyutlu bir yüzeyde(düzlemde) gösterebilmemiz için Perspektif çizim teknikleri kullanılmaktadır. 8. Sınıf Matematik Öğretim Programına göre, geometri öğrenme alanının izdüşüm alt öğrenme alanında “Bir küpün, bir prizmanın belli bir mesafeden görünümünün perspektif çizimini yapar” kazanımı yer almaktadır (MEB, 2013). Bu çalışmada 8. sınıf öğrencilerine küpün ve prizmanın perspektif çizimlerinin sınıf içinde etkinliklerle verilmesinin ardından öğrencileri değerlendirmek amaçlı günlük hayat uygulaması içeren bir Webquest uygulandı. Webquestler, öğrencilerin etkileşim içinde oldukları, gerekli bilgilerin bir bölümünü ve ya tamamını internet kaynaklarından elde ettiği araştırmaya dayalı bir aktivitedir (Dodge, 1997). Bu çalışmada kullanılan Webquest, perspektif çizim kazanımlarını içermektedir. Öğrencilerin 3-4 kişilik gruplar halinde çalışarak verilen görevleri tamamlamaları istendi. Öğretmenin araştırmacı olduğu aksiyon(eylem) araştırması deseninde yürütülen bu çalışmadan elde edilen sonuçlar sunumda paylaşılacaktır.

Anahtar sözcükler: perspektif çizim, Webquest, 8. sınıf öğrencileri

ABSTRACT: While the world, we live in, is three-dimensional, display screen is a two-dimensional plane. Perspective drawing techniques are used because of the three-dimensional object to be able to show a two-dimensional surface(plane). According to the 8th Grade Mathematics Curriculum, in the projection field of sub-learning of geometry learning area "students make the perspective drawing of a cube, a prism of the view from a distance" gain is located(MEB, 2013). In this study, the 8th grade students in the class of perspective drawings of cubes and prisms were provided with activity. Then a Webquest containing the daily life application was applied for assessing the students. Webquests is an activity based on the research that students to interact and all of the required information obtained from internet sources(Dodge, 1997). Webquest used in this study, include gains of perspective drawing. Working groups of 3-4 students were asked to complete the task. The results obtained from this study that action (action) research conducted in the pattern, teachers as researchers, will be shared in the presentation.

Key words: perspective drawing, Webquest, 8th grade students.

SOCIAL WORK AND ICT-SOME ETHICAL ISSUES

Lecturer. Mirsada ABDURRAHMANI
University of Shkodra “Luigj Gurakuqi ”Shkoder Albania
Faculty of Education Sciences
E mail: mirsada.abdurrahmani@hotmail.com

Dr. Jozef BUSHATI
University of Shkodra “Luigj Gurakuqi” Shkoder Albania
Advising Information Students Center
E mail: jozefbushati@gmail.com

Lecturer. Edit LEZHA
University of Shkodra “Luigj Gurakuqi ”Shkoder Albania
Faculty of Education Sciences
E mail: editlezha@gmail.com

Lecturer. Bujane TOPALLI
University of Shkodra “Luigj Gurakuqi ”Shkoder Albania
Faculty of Education Sciences
E mail: bujane.topalli@yahoo.com

ABSTRACT: There is a tendency to see a new development in the field of ICT-s, and possibly taking advantages of this new technology can be brought to social work. Social work faces a critical need to incorporate ICTs into training social workers, delivering social work services, and the conduct of social work research. The increasing use of ICTs in social work raises some new questions in relation with confidentiality, privacy and data security. Regardless of the level of practice, ICTs will continue influencing the careers of social workers and the clients they serve. Social workers recognize the central importance of human relationships but in the same time social workers need to have an understanding of the roles that such ICTs may play in the lives of their clients. This paper also identifies potential pitfalls and challenges with respect to the adoption of ICT, with recommendations for advancing their use in practice, education. Social workers also need ICT competencies in order to effectively lead different types of social change initiatives or collaborate with professionals of other disciplines who are using ICTs as part of existing strategies.

Key words: ICT, social work, practice, ethic

INTRODUCTION

The term technology refers to the practical application of scientific knowledge, defined as “any electronically mediated activity” used by social workers in the administration and evaluation of social services. We already noted that the ICT has multiple policy objectives, including: increasing accountability, transparency, delivering better management and standardization of good practice. This paper aims to represent how technology can be used in social work practice and the ethical issues. Furthermore, the objective of this study is to identify how these issues can be exceed and the service be effective and secure.

LITERATURE REVIEW

Every aspect of human life today is affected by information and communication technology (ICT) and the future even promises more transformations (Tregeagle & Darcy, 2008; Lahlou, 2008). Technology has played and continue to play a significant role in social work. practice.

Taylor describes four other uses of computers:

- Billing systems – including billing third-party payers and figuring the payroll
- Word processing –including storing progress notes and printing personalised fund raising letters
- Decision support – forecasting future services or budget needs and
- Specialized uses –e.g. scoring personality tests, conducting client assessment interviews.

The council of Social Work in Education 2008 recognise the importance of technology to social work practice and education. Many social services agencies now use computers to increase the efficiency and utility of their information systems Management –information systems for social service organizations are basic to good evaluation. A good management information system should make a sense to the social worker, administrator and the researcher.

Without technology, social work practice today would be ineffective. According to European perspective there are identified a number of challenges in the context of restructuring of public social services and Ict will be an effective instrument for these modern services.

Social work educators need to be capable with ICT in order to design activities, projects that reflect the real-world use of ICT. Beyond higher education, continuing education opportunities respond to recent technology advances which are also necessary in order to help social workers to stay in current with the most relevant and useful technologies. Other disciplines have recognized the importance of ICT and consider it to be important for professional development. One of the dangers of a technology-led approach is that social work need to be understood primarily in the light of the aims of ICT developers, and evaluated in their terms.

Darcy (2008) acknowledge the importance of technology in social work; , about the deployment of ICT in modern welfare practice serves the interests of social work managers and administrators more than the mission of the profession, especially and more importantly the interests of service users.

The most important, is that they should always refer to the NASW Code of Ethics and the NASW/ASWB Standards for Technology and Social Work Practice for guidance in the deployment of technology in practice. Ethical considerations for ICT related issues first appeared under the topic “Information ethics” in the Annual Review of Information Science and Technology in 1992. Individuals and organisations therefore be aware for the emergency need to be ethically sensitive as they deploy ICT on their operations. This new development of on line services, offers a lot of advantages to service user in the same time various ethical dilemmas become apparent as we try to define the limits of confidentiality in social work. One of the most important is the right of service users to privacy means that securing the confidentiality of personal records.

THE IMPACT OF ICT IN THE RELATION SERVICE USER –SOCIAL WORKER

Such interactions or Internet services may be question-and-answer chats, emails about appointments, which may be very helpful to home-bound clients with debilitating illnesses, elderly, women’s with babies etc. We know that social work is an imperative work that has a significant emotional content working face to face with service users who may be distressed, angry or otherwise disturbing in their presentation. There is a evidence whom ICT has affected the relation between social workers and services users. Parton (2008), opinion is that technology has made social work more “informational” and less “social” (p. 253), applying technology to practice is good, but one should remember that technology does not care for people, technology is just a tool one utilizes to facilitate care or service delivery.

In some studies are tracked patterns of communication within online groups, and have found that many of the processes used are the same as those used in face-to-face self-help groups (Finn, 1999; Perron, 2002; Salem, Bogat, & Reid, 1997). Given the prevalence of online relationships, social workers and other human service professionals must be aware of the positive (e.g., social support, see Perron, 2002), and negative effects (e.g., cyber-bullying, see Hinduja & Patchin, 2008)

Currently, the social work curricula emphasize the importance and development of in-person relationships, while little attention was for the role of online relationships and computer-mediated relationships. The relation with the social worker is human they can see directly with each other but with computer isn’t the same. To remain relevant social work needs to continue to influence systems for the benefit of society while reviewing and updating theories and models to reflect current lifestyles, modes and patterns of communication.

SUPERVISION AND CONTINOUS ICT EDUCATION

Continuing education and staff development should address current knowledge and emerging developments related to social work practice and ethics.

Social workers should strive to become and remain proficient in professional practice, they should remain current with the news in research. The reality is that the majority of research findings are disseminated and accessed electronically via the Internet.

CHALLENGES OF ICT AND SOCIAL WORK PRACTICE

Despite the continued growth and expansion of technologies, a lot of disadvantaged persons still do not have access to ICT.

The social worker using technologies must consider the advantages and disadvantages of online services (Car & Sheikh, 2004). Without proper training, social workers in practice are at risk of delivering poor quality services or facing legal or ethical issues.

RECOMMENDATIONS

Based on the theoretical, empirical findings and on conclusions derived, it is necessary to consider certain recommendations:

Regarding the use of new technologies social worker has to do with client privacy, competence in the specific technology is important, they need to understand how to properly use computerized client information and know the risks involved.

Social work supervisors should take reasonable steps to provide or arrange for continuing education and staff development and advocate for adequate resources to meet clients' needs. Supervision is very necessary for implementation of technology especially in developing countries where ICT is relatively new field especially in social work.

REFERENCES

Contemporary Social Work – An introduction to Social Work and Social Welfare – Donald Brieland ,Lela B.Costin , Charles R.Atherton.

Social work & ICT – Andrew Hill Ian Shaw 2011. ISBN 978-1-84920-055-4

Information and Communication Technologies in Social Work- Brian E. Perron

School of Social Work at the University of Michigan- Harry O. Taylor
Bargh JA, McKenna K, Fitzsimons GM. Can you see the real me? Activation and expression of the“true self” on the internet. Journal of Social Issues. 2002;

National Association of Social Workers. Code of ethics of the National Association of Social Workers.

Bargh JA, McKenna K. The internet and social life. Annual Review of Psychology. 2004; 55:573–590.

Open University. ICTs in everyday life.

Abubakar, B. M. & Hassan, B. B. (2010). Incorporating information technology in library and information science curriculum in Nigeria. A strategy for survival in the 21 st Century.

Aqili, S.V & Moghaddam, A. I. (2008). Bridging the digital divide: The role of librarians and information professionals in the third millennium.

Contemporary social work-an introduction to social work and Social Welfare. Donald Brieland , Lela B.Costin , Charles R. Atherton.

The Electronic Library

Theoretical pathways to the future: Globalization, ICT and social work theory and practice. Deborah West, David Heath. Charles Darwin University, Australia

Trends in consumer internet use. Art, M. M. (2009). 226-223, LIMRA's Market Facts Quarterly

Blended learning as a new approach to social work education. 52-59. Ayala, J. S. (2009).
Journal of Social Work Education, 45

Responding to CSWE technology guidelines, 277-288. Beaulaurier, R. L., & Radisch, M. A. (2005).: A literature review and four approaches to computerization. Journal of Teaching in Social Work, 25

Telecommunications techniques in social work distance education. 129-152. Blakely, T., & Shoenherr, P. (1995).

Journal of Continuing Social Work Education, 6

.Bradley, L.J. & Hendrick, B (2009). 8-12. E-mail and ethical issues.

The Family Journal, 17

Burton, J., & van den Broek, D. (2009). 267-271. Accountable and countable: Information management systems and the bureaucratization of social work.

British Journal of Social Work, 39 , 1326-1342. Butcher, J. N., Perry, J., & Hahn, J. (2004). Computers in clinical assessment: Historical developments, present status, and future challenges.

Council on Social Work Education. (2008). 114-120

Social Work in the ICT Age: How to Ensure Ethical and Competent Practice in the 21 st Century and Beyond
By J. Kerkula Foeday December 21, 2011

SEVERAL VIEWS OF TEACHING PHYSICS

MSC. Sotiraq MARKO

Lecturer at “Fan. S. Noli” University of Korçë.
e-mail: sotiraqmarko@gmail.com

MSC. Lorena KELO

Lecturer at “Fan. S. Noli” University of Korçë.
e-mail: kelo.lorena@yahoo.com

MSC. Suela SERANI

Lecturer at “Luigj Gurakuqi” University of Shkodër.
seranисуела@gmail.com

SUMMARY

The science of physics neither raises nor solves the “problems” of teaching the laws of nature discovered so far. Ways of conveying knowledge of physics to the student are considered by the methodology of teaching physics. In this presentation we will consider the methodology of active learning based on a problematic situation set up by me, the lecturer of physics.

To explain this methodology of teaching I have used my personal experience in teaching physics as well as my personal results in the process.

The structure of knowledge in physics requires a variety of aspects such as recognition, meaning, application, analysis, as well as generalization of phenomena, connection of sizes-amounts, finding out laws, condition of application, basic principles of physics, etc.

Problematic situation should:

- a. involve students thoroughly and intensively deeper than the traditional methodology, especially during the teaching process in schoolrooms;
- b. emphasize the cognitive ability before conveying knowledge;
- c. Insist that the student find arguments before finding the right answer;
- d. Convince the student that physics is coherent rather than a set related with concepts and problems;
- e. Clarify that learning process happens via research and active understanding.

Key words and phrases; Process of teaching, development of individuality, science of physics, scientific methodology, problematic and research methodology, physical model, formulae, hypothesis, analyse data, apply, conclusion.

PRINCIPLES THAT GUARANTEE QUALITY AND SUCCESS IN TEACHING

1. Conception of teaching:

Teaching is one of the most important processes in achieving success in educational service offered to both students and pupils.

During this process the Lecturer stimulates debate, encourages active participation and critical thinking of the students based on the processing of the threefold information, thesis, antithesis, synthesis.

What makes teaching effective and qualitative:

Firstly: Non-paternal communication.

It is true that in general terms the Lecturer possesses knowledge and/or sense of analysis superior to that of the student; however, this should not lead to interrupting communication. Each debate between Lecturer and student should seek the identification of common ground and differences in evaluation.

Secondly, the lecturer should play the role of the moderator.

The lecturer should make space for debate, should accept a variety of reasons articulating solutions and/or giving conclusions achieving specific objectives preceding the establishment of a sustainable scientific education.

2. “Pluralistic” character of information.

The student should be exposed to all viewpoints, theories which populate the market of prevailing ideas, theoretical debates, and practical solutions.

To be effective in educating the student we should meet to factors:

- A qualitative preparation of the professorate academic-wise and professional-wise. :
- Freedom of expression.
-

3. Communication.

Communication during the teaching process and behavioral becoming is one of the most important pillars in education.

However, to ensure effective teaching the process, the Lecturer should rely on three pillars:

1. Professional preparation;
2. Pedagogical skills;
3. Communicational skills

Everything that happens in the auditorium is created and supported by the process of communication. Term Curriculum, teaching strategies, explanation of phenomena, critic or estimation of the students proficiency, is accomplished via communication.

Positive results are achievable when:

- The teaching methodology is based on active learning in creating and solving problematic situations.
- The problem to be solved is plainly presented.
- Pros and cons are debated.
- Main thesis is defined, so that through communication, we achieve mutual understanding.
- The argument is well-supported by methodology.
-

4. Lecturer-student relations.

Tolerance and flexibility should prevail.

Straight and righteous relations and responsibilities in the many-component estimation are indispensable.

The concepts that help creating such an atmosphere are:

1) The student's concept regarding school.

- ✓ Schooling is a choice, a desire, a personal calculation, that requires responsibility, investment, and seriousness.
- ✓ Free market offers jobs.
- ✓ Jobs demand high performance quality.
- ✓ Quality is obtained during qualitative education.

2) Lecturer's role as a concept.

- ✓ He/she should guide and help the student in case of difficulties advising him/her in the process of becoming.

3) Mechanism of estimation.

Estimation is the process of measuring performance and progress, highlighting the values of the synergy of human knowledge and skills.

Estimation is a delicate process of teaching, because in many cases it tends to be subjective. It is a big challenge for the Albanian school to fight subjectivism.

Sometimes, the words 'test' and 'estimation' are considered synonyms. It is not right.

A test is a method of measuring knowledge and/or skills of a student in a certain field, emphasizing so the concepts of methodology and measure [1]"; a test is a specific instrument which is designed carefully. Furthermore, a detailed diagram which displays a point system should be attached to each test.

While the test is a procedure foreseen in the teaching plan, where the student makes his best to achieve the best possible result, estimation is a continuous process which covers a broader spectrum.

Each time a student answers a question, makes a comment, expresses a word or a new concept, the teacher instinctively estimates the performance of the student.

According to Brown [2], a good teacher never stops estimating his students, whether such an estimation is accidental or on purpose.

The test is a useful and efficient means to estimating the student's knowledge. However, it is part of other procedures and ways the teacher follows to estimate his student.

Thus, a test is only a subset of estimation. It is not the only means of estimating the student.

REAL PROBLEMS IN APPLYING SUCH PRINCIPLES

- A. Traditional teaching lack the power to establish solid knowledge, if the alternative teaching is ignored.
- B. The multifold information is missing.
In the 'alter-text' you find scientific and methodological deficiencies in treating subject information.
There are no bookstores where one finds books on physics and/or variety of accessible information.
- C. Prevalence of word inflation.
Lack of clarity of thought and scientific expression.
- D. Authoritarianism of teacher-student relationships.
Absence of a more objective assessment.

SEVERAL ELEMENETS OF METHODOLOGY ON PHYSICS

[1] Brown, H.D. 2007 *Teaching by Principles "An interactive Approach to Language Pedagogy"* Pearson, Longman, p. 445

[2] Ibidem

The science of physics neither raises nor solves the “problems” of teaching the laws of nature discovered so far.

Ways of conveying knowledge of physics to the student are considered by the methodology of teaching physics, which, being closely related with the science of pedagogy, will lead to desirable results.

There is a unique link between the curriculum content and teaching methodology, where the content leads and methodology follows.

The methods of giving and processing knowledge creating skills and habits include: explanation, narration, conversation, lectures, demonstration, instruction, problem-presentation, academic-competition, experimentation, modeling, etc.

Based on long personal experience in teaching physics and the best practices will highlight:

Possessing scientific quality of the course content.

Construction and implementation of research and problematic method in the teaching process.

This method consists in transmission and acquisition of new knowledge creating problematic situations solving problems within the contradiction of theoretical and practical cognitive tasks.

So, the creation of a problematic situation is essential.

This situation arises in physics based on the detection of inconsistencies between the physical knowledge previously acquired and the impossibility of solving the new problems based on the experience previously acquired.

Each lesson topic throughout the course of general physics allows the creation of a problematic situation where one should:

1. Understand the problematic situation.
2. Analyze and define the problem.
3. Searching ways to solving the problem.
4. Formulate hypotheses.
5. Argue and verify the truth in them.
6. Solve the problem.
7. Check and verify the results.

In the learning process, in accordance with the concrete material to be examined, laying problematic situation will require placing the student in the center.

A problematic situation in class requires:

- Placing as much emphasis as possible on cognitive ability, while conveying knowledge;
- Insisting that student find arguments while expecting for the right answer.
- Telling the student the idea that physics is a coherent not a heterogeneous sum up of concepts and problems;
- Cultivating that learning occurs through active understanding and scientific research.
- Each physical model represents the structure of a system with its features. The multiple representations taken together provide the structure of the system.

It is presented with a symbolic representation through words, diagrams and mathematical equations, sketches and other conventional elements.

A variety of models:

1. Hypothesis;
2. Phenomenology;
3. Approximation;
4. Simplification;
5. Analogy;
6. Thoughtful experimentation;

But their common goal is to facilitate solutions to various problems;

- Scientific explanations are reviewed and formulated using logic and evidence.

In the question-answer process students need to argue their opinions.

What would be the expected product?

- Training students in the conception of experimental procedures.
- Interpretation of results and/or data.

Objectives:

Despite the ways of organizing teaching, in the selection of material must meet:

1. Clear and logical presentation of the basic concepts and principles of physics.
 2. Formation and understanding of sustainable concepts and principles through a broad range of applications really proven in world experiences.
 3. Developing skills for solving problems through a carefully organized approach. To meet these objectives, teachers should:
- Present well-organized physical arguments focused in accordance with to specific objectives.

- Motivate students through practical examples that demonstrate the role of physics as a basic science to other scientific disciplines.
Independent and/or guided exercise during seminars.
- Students face hundreds of problems in physics courses. A relatively small number of basic principles form the basis of these problems.
- When faced with a new application, a physics professor forms a pattern of problem that can be solved in a simple way by identifying the fundamental principle that applies to this problem.
In this very important element for scientific establishment it is recommended:
 - The selection of texts with additional literature for seminar sessions where “Solved Problems” are considered.
 - The selection of those problems that offer an approach of analytical models where their solution consolidates theoretical concepts.
 - The interpretation of physical phenomena in a quantitative assessment of physical sizes.
 - The assessment of logical connections between the phenomenon and quantity where research and practical application in many fields has arisen.
 - Physics problems carefully selected are a very good source^[3] of encouraging the student to work independently forming lasting scientific knowledge.

R.P. Feynman, Nobel laureate in physics, said:

"You do not know anything for as long as you do not practice"[4]

In line with this assertion, we strongly recommend: to develop the necessary skills one should solve a wide range of problems.

- The student's ability to solve problems arguing the solution will be one of the main tests of acquisition of knowledge of physics.
- The necessity of understanding the basic concepts and principles before making the due efforts to solving problems.
- Searching for alternative solutions to the same problem.
For example: Students can solve problems in mechanics, using Newton's laws, but more often an alternative method based on energy considerations is more direct.
- Enabling the student to solve similar problems working independently.
- Problem-solving approach should be carefully planned.
- Systematic plan is especially important when a problem involves several concepts.

Model Of A Problematic Situation

Theme: The energy of the magnetic field^[5].

Situation lay out: Suppose an electrical circuit in a non ferromagnetic and homogeneous situation.

Present the circuit as shown in figure:

Recognition: Which are the elements of the circuit^[6]?

Understanding: Should energy depend on the orientation of the circuit?

Analysis: What will happen when switch S is on?

Statement: As (ϵ) is included in the circuit, current shall start streaming, consequently self-induction (ϵ_{si}) shall arise.

Analysis: Which is the reason that (ϵ_{si}) arise?

Application: The law of Ohm is written regarding the moment values of these

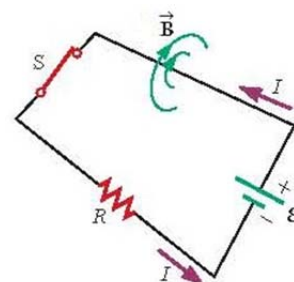

^[3] Rexhep Mejdani, Script I and II, Tiranë, 1974

Ahmad A. Kamal, 1000 Solved Problems in Classical Physics, © Springer-Verlag Berlin Heidelberg 2011;

B. S. Belikov, General methods for solving physics problems, Moscow 1988;

A. A. Pinsky Problems in Physics Moscow 1980

B. Bukhovtsev, V. Krivchenkov, G. Myakishev, V. Shalnov, Problems in Elementary Physics, Moscow 1978;

I. E. Irodov, Problems in General Physics, Moscow 1988;

S. P. Myasnikov, T. N. Osanova Selected Problems on Physics, Moscow 1990;

L. A. Sena A Collection of Questions and Problems in Physics, Moscow 1988;

V. S. Wolkenstein, Problems in General Physics, Moscow 1987;

V. Zubov, V. Shalnov, Problems in Physics, Moscow 1985;

^[4] Physics for Scientists and Engineers With Modern Physics, Ninth Edition Raymond A. Serway and John W. Jewett, Jr. pp 35 (2014)

^[5] K. A. Qendro, P. S. Naumi, Course of general physics, Part III, Tiranë 1981

^[6] Correct answers shall be received by students, after discussions, accordingly.

amounts:

$$\varepsilon + \varepsilon_{si} = IR \quad (1)$$

Practical action: Multiply both sides of equation by: $I dt$ and the value of (ε) of the self-induction $\varepsilon_{si} = -L \frac{dI}{dt}$ is substituted then the complete equation is written:

$$\varepsilon I dt = I^2 R dt + LI dI \quad (2)$$

Analysis: Evaluate the energy terms of the equation (2)

The left side presents the energy given by the source during the time dt , when the stationary regime is set regarding the condition $I = 0$, all energy is transformed into thermal energy whereas when the current changes, not all energy is transformed into thermal energy.

The term shown: $LI dI$ during the change of current intensity.

Conclusion: When the current changes the source gives a supplementary energy which is evaluated by the second term of the equation (2) $LI dI$.

Outcome: The only phenomenon that is shown with the placement of stationary current in the circuit is the creation of the magnetic field that varies with the changing I that creates it.

If the current does not change then the magnetic field does not change.

So, to keep constant magnetic field, we should not waste energy.

Analysis: The amount: $LI dI$ is a supplementary energy instead of thermal energy when current is changed from $I = 0$ to $I = I_0$ which shall exist until the set of current I_0 .

Application: By calculating this energy from $I = 0$ to $I = I_0$ we find the value of the supplementary energy:

$$W = \int_0^{I_0} LI dI = L \int_0^{I_0} I dI = \frac{1}{2} LI_0^2 \quad (3)$$

Analysis: Let's accept that there is current in the circuit. Let's suppose that we remove the source of current and turn on the remaining part of the circuit.

Discussion: What will happen then?

Analysis: Current tends to decrease, consequently (ε) of self-induction shall arise which acts in the circuit $\varepsilon_{si} = -L \frac{dI}{dt}$

Application: Let's apply the law of Ohm in this circuit: $-L \frac{dI}{dt} = IR \quad (4)$

Let's multiply both sides of equation by $I dt$ and we obtain: $-LI dI = I^2 R dt \quad (5)$

Let's analyze the energy terms of the equation (5)

Conclusion: The left side presents the energy given by ε_{si} , whereas the right side presents thermal energy.

Outcome: All this energy is transformed into thermal energy within the circuit.

Application: Let's calculate the amount of energy that is released from the moment $t = 0$ to ∞

$$Q = \int_0^\infty I^2 R dt = -L \int_{I_0}^0 I dI \text{ ose } Q = \frac{1}{2} LI_0^2 \quad (6)$$

Conclusion: So we have a circuit with thermal energy obtained equal to the supplementary consumption.

Analysis: The only occurrence regarding the "disappearance" of current is the "disappearance" of magnetic field.

It is obvious that the amount of energy obtained when the magnetic field disappears is equal to that we consume to create it.

Outcome: In such conditions it is natural to accept that magnetic field possesses energy.

Analysis: In the presented case we have the circuit with electrical current and the magnetic field in its presence.

Naturally we are not able to answer the question:

Where is such energy located?

In the space or in the circuit with current that creates the magnetic field?

Discussion: Is it possible that the magnetic field is created without the presence of the electric current?

Is it acceptable that the electromagnetic waves possess energy?

Conclusion: After calculation it is noticed that this energy is numerically equal to the energy given by (ε_{ai}) , therefore to calculate it we dealt only with the second term of the equation (2) which we call electromagnetic energy located in the field.

OUTCOME:

Analyzing of basic principles that guarantees success and quality in teaching, getting to know what guarantees such principles dealt with in general terms, gave us the chance to present several thoughts on the Methodology of Physics, laying out a simple model of a problematic situation.

Choosing this theme as a suggested class model aimed the objective that the knowledge on Physics such as recognition, understanding, application, analysis, generalization in studying occurrences, connection of amounts, discovery of laws, conditions in application, essential principles, etc, must ensure an active

cooperation between the lecturer and the student to following every step through which scientific knowledge is conveyed in realizing the objectives of scientific research:

To discover new facts

To verify and prove important facts.

To analyze an occurrence or process in which cause-result relation is identified.

THE PHENOMENON OF CYBER BULLYING IN ALBANIAN CONTEXT: AN EXPLORATIVE STUDY OF STUDENTS' PERCEPTIONS

Dr. Jozef BUSHATI

University of Shkodra "Luigj Gurakuqi" Shkoder Albania
Advising Information Students Center
E mail: jozefbushati@gmail.com

Lecturer. Edit LEZHA

University of Shkodra "Luigj Gurakuqi" Shkoder Albania
Faculty of Education Sciences
E mail: editlezha@gmail.com

Prof.as.dr. Gezim DIBRA

University of Shkodra "Luigj Gurakuqi" Shkoder Albania
Faculty of Education Sciences
E mail: gdsh53@yahoo.com

Lecturer. Ardian TANA

University of Elbasan "Aleksander Xhuvani" Albania
Faculty of Education Sciences
E mail: ardiantana@yahoo.it

ABSTRACT: Exponential growth of technology usage has further expanded the concept of an information age. In the prolonged transition of Albania society the perception of the virtual freedom has changed radically. During the last years the Albanian government implemented the extension of Internet connectivity in the rural and urban schools. On the other hand, private cell mobiles companies extended the internet connectivity offering it with affordable fees for the mass population. These initiatives changed the usage of virtual freedom making its usage massive for everyone. Despite the variety of age frequencies everybody can have access to virtual communication by simple gadgets to sophisticated ones. This freedom of communication has affected many social aspects which one of them is cyber bullying. Cyber bullying is defined as using electronic communication to torment others through devices such as Internet, e-mail, text messages or even social networking sites. Most people do not recognize the symptoms of being stalking online and the techniques a cyber stalker employs to target them. The purpose of this exploratory study is to give a brief overview of current knowledge in the literature about cyber bullying. Also, this paper will look at the perceptions of Albanian college students regarding issues related to cyber-bullying phenomenon based on descriptive data gathered out from a comprehensive questionnaire. Alternative tactics for preventing this phenomenon in the field of education were discussed in this study.

Key words: technology, transition, internet extension, cyber bullying, education.

INTRODUCTION

During the last years the Albanian government implemented the extension of Internet connectivity in the rural and urban schools. On the other hand, private cell mobiles companies extended the internet connectivity offering it with affordable fees for the mass population. These initiatives changed the usage of virtual freedom making its usage massive for everyone. Despite the variety of age frequencies everybody can have access to virtual communication by simple gadgets to sophisticated ones. This freedom of communication has affected many social aspects which one of them is cyber bullying. Cyber bullying is defined as using electronic communication to torment others through devices such as Internet, e-mail, text messages or even social networking sites.

Electronic bullying is different from traditional bullying because the anonymity provided by technologies removes the bully from the consequences caused by their actions. Since cyber bullies are virtually removed from their victims, the opportunities for feelings of regret, remorse or sympathy for the victim are removed (Slonje & Smith, 2008). Three main roles that someone may take in an instance of cyber bullying are being *the bully*, *the target*, or *the bystander* (Willard, 2007a). *The bully* is the person who harasses or puts down other people. Individuals may also be *the targets*. These are the people who targeted by the cyber bully, and they are sometimes also known as the victim. Although many individuals may think they are not participating in bullying behavior, being a bystander also means that one is involved in a bullying act.

Willard (2007a) identified two types of bystanders, *helpful bystanders* and *harmful bystanders*. Helpful bystanders are individuals who take action to stop the bully by either protesting against the bullying act, by providing both physical and emotional support for the target, or by seeking the help of an adult to intervene in the situation. Hurtful bystanders, on the other hand, are involved either by supporting and encouraging the bullying behavior or by simply doing nothing to intervene or seek help for the target.

The definition of cyber bullying illustrates that, while it is a form of and involves all of the non-physical attributes of bullying, it is carried out through devices capable of electronic communication. Cyber bullying can assume many different articulations, thus it is difficult to define in a simple sentence (Kowalski, et. al., 2008). However, there are six forms of cyber bullying that are most common:

Harassment: Repeatedly sending offensive, rude, and insulting messages. *Denigration*: Distributing information about another that is derogatory and untrue through posting it on a Web page, sending it to others through email or instant messaging, or posting or sending digitally altered photos of someone. *Flaming*: Online “fighting” using electronic messages with angry, vulgar language. *Impersonation*: Breaking into an email or social networking account and using that person’s online identity to send or post vicious or embarrassing material to/about others.

Outing and Trickery: Sharing someone’s secrets or embarrassing information, or tricking someone into revealing secrets or embarrassing information and forwarding it to others. *Cyber Stalking*: Repeatedly sending messages that include threats of harm or are highly intimidating, or engaging in other online activities that make a person afraid for his or her safety (depending on the content of the message, it may be illegal) (Willard, 2007). Although persons involved in cyber bullying identify other persons engaged in similar behavior and believe this behavior is acceptable, cyber bullies are negatively impacting cyber-victims (Brown et al, 2006). Cyber bullying can also be perpetrated through exclusion or ostracism. Examples of this include obviation from groups, chat rooms, or websites that can be the result of another person changing their password, exclusion or omission from a buddy list, and/or being ganged up on by other members (Kowalski et. al, 2008, pp. 49-50).

Cyber bullying is secretive and may spread information rapidly from one person to another (Li, 2006). Results from a study conducted by Ybarra and Mitchell (2004a) found that aggressive adolescents frequently targeted people they knew in conventional environments; 84% of the aggressors indicated knowing the target in person. Cyber bullies may target individuals in their social group, knowing the target’s address, phone number, or email due to their past friendship which they use to send threatening messages (Besag, 2006; Ybarra & Mitchell, 2004a). Online and offline bullying are rooted in aggression, which may suggest that the internet may simply be an extension of school bullying (Ybarra & Mitchell, 2004a). Six major means through which cyber bullying may occur are: instant messaging, e-mail, chat rooms or bash boards, small text messaging, web sites, and voting booths (Beale & Hall, 2007). Messaging devices are allowing cyber bullies to attack their victims through means of instant messages. These devices allow users to add other people to their user lists (Beale & Hall, 2007). The devices notify the user when someone comes online, allowing them to initiate a conversation with them. However, cyber bullies can easily switch screen names that hide their true identities, allowing for potential cyber bullying to continue. Cyber bullies are able to send threatening e-mail messages to their victims through e-mail (Beale & Hall, 2007). Although most e-mail programs allow for particular individuals to be blocked, these screening devices are limited. Although it may be easy to identify where an e-mail originated, it is nearly impossible to actually prove who wrote and sent the message. The loss for accountability is one thing that may draw cyber bullies to using this mean. Another form through which cyber bullies harass their victims is through chat rooms or bash boards (Beale & Hall, 2007).

METHODS

This research study is a descriptive exploratory study. Descriptive research is used to describe characteristics of a population or phenomenon being studied. The purpose of this descriptive study is to give a brief overview of current knowledge in the literature about cyber bullying. Also, this paper aims to analyze the perceptions of Albanian college students regarding issues related to cyber-bullying phenomenon based on descriptive data gathered out from a comprehensive questionnaire. The study was designed based on this research questions:

1. What is the perception of cyber bullying phenomenon and what are the symptoms?
2. What is the perception of the consequences of cyber bullying?
3. What kind of cyber bullying form is more used?
4. What is the most used Internet application for cyber bullying?
5. What is the perception for preventing cyber bullying?

Data for this study was gathered using both mixed methods. For the first phase it was used quantitative method that was based on delivering o a self-designed comprehensive questionnaire which was based to determine the level of comprehension about cyber bullying phenomenon. It was filled out completely from 572 students from

four different Albanian public universities, who were selected participants by using convenience sampling that is used for both the quantitative and qualitative portions of the study. Participants were assured that individual responses would never be identified and were only be used for research purpose only. For the second phase of the study only 382 students who scored an average level of cyber bullying knowledge were recruited to continue being participants of the research , 48 students dropped out and in total n= 334 students participated in the second phase by conducting individual in depth interview via email.

FINDINGS AND CONCLUSIONS

What really helped in giving a consolidated interpretation of the difference level perception of students was the interview codification . Albanian students perceptions about how cyberbullying occurs is not well defined. They have problems in explaining the definition of term “ cyberbullying” by focusing only in few symptoms such as: mocking and using fake identities to denigrate. Girls reported being a cyber bully mostly with girls who they know in high school and very few reported to bully girls from their home university. On the other hand, boys mostly cyber bully girls than boys who they know from their home university. For girls the type of bully that it was used most was denigration and harassment but for boys was flaming and impersonation. According to the analysed of gathered data , 1 in 2 reported being bullied at least once via facebook which was the most frequent way for cyberbullying followed by messenger and cell phone sms. For the section of cyberbullying prevention during the first phase 72% declared that education and media were powerful mediator for informing and sensibilizing cyberbullying phenomenon. But, few alternatives were given in opened-questions for the prevention of cyber bullying by limited it in training and media awareness campaign. In general students reported that the consequences of bullying were based in emotional consequences such as; anxiety, anger and low self – esteem. These findings should be considered for further long-term studies. This explorative study is a baseline study for further researches of digital stress in the context of academe life. Researchers tend to expand their research in all public universities of Albania. Also, a more detailed examination of variables such as gender, status, type of faculties and individual features such as locus of control etc will be considered to be examined statistically with types of cyberbullying experienced from technology usage.

RECOMMENDATIONS

This phenomenon it's a new one for Albanian society and there are just a few empirical studies about cyber bullying. In order to find out the prevalence of this phenomenon in schools, researchers from public and private institutions should be encouraged to develop accurate scientific researches. According to our findings, it is necessary to provide student education about cyber bullying in which extra curriculum trainings would incorporate cyber bullying into life skills or bullying prevention classes. Education policymakers should review policies and procedures related to Internet and mobile communication devices, which may include restricting the use of mobile communication devices during the school day and monitoring of Internet use. Collaboration between multiple resources and personnel is essential in utilizing this phenomenon and understanding ways to deal with cyber bullying within the home and school setting. Education policy makers can utilize prevention efforts involve the education of students about safe Internet usage, collaborating with support personnel to help victims of cyber bullying cope, and establishing firm school policies to prevent cyber bullying.

REFERENCES

- Beale, A. V. & Hall, K. R. (2007). Cyberbullying: What school administrators (and parents) can do? *The Clearing House*. 81, 8-12.
- Brown, K., Jackson, M., & Cassidy, W. (2006). Cyber-bullying: developing policy to direct responses that are equitable and effective in addressing this social form of bullying. *Canadian Journal of Educational Administration and Policy*, 57.
- Fryer, W.A. (2006, November 20). Addressing cyberbullying in schools. *The Tech Edge: The Journal of the Texas Computer Education Association*.
- Kowalski, R. M., & Limber, S. P., & Agatston, P.W. (2008). *Cyber Bullying: Bullying in the Digital Age*. Malden, Massachusetts: Blackwell Publishing.
- Li, Q. (2006). Cyber bullying in schools: a research of gender differences. *School Psychology International*, 27(2), 157-170.
- Olweus, D. (2011). *What is Bullying?* Retrieved July, 19, 2011, from Olweus Bullying Prevention Program, The World's Foremost Bullying Prevention Program website
- Sionje, R., & Smith, P. K. (2008). Cyber bullying: Another main type of bullying? *Scandinavian Journal of Psychology*, 49, 147-154,

Willard, N. 2007a. *An educator's guide to cyber bullying and cyber threats*

Wolfsberg, J. S. (2006). Student safety from cyber bullies, in chat rooms and in instant messaging. *Education Digest*, 72(2), 33-37.

Ybarra, M. I. & Mitchell, K. J. (2004). Youth engaging in online harassment: Associations with caregiver-child relationships, Internet use, and personal characteristics. *Journal of Adolescence*, 27, 319-336.

CATEGORIZING MATHEMATICS KNOWLEDGE TO USE ICT IN MATHEMATICS EDUCATION

Reza HOSSEINGHOLIZADEH
Shabestar Branch, Islamic Azad University, Shabestar, Iran
re331@yahoo.com

Ebrahim POURREZA
Shabestar Branch, Islamic Azad University, Shabestar, Iran
pourreza@tabrizu.ac.ir

ABSTRACT: This paper makes an attempt to investigate the nature of mathematics knowledge and ICT-information and communication technology-potential. It proposes that mathematics knowledge be categorized into two parts, Meta knowledge and executive knowledge. Each type of the knowledge requires entirely different planning from the instructors, if they wanted to use ICT in mathematics education. To this end, it is proposed that the class instructor be substituted with a class director, who has been trained by mathematics education system for this purpose. The class director duties will be briefly discussed. When the class director executes the model, the mooted method, s/he is going to produce a valuable lecture which is called evolved-lecture.

Key words: evolved-lecture, Meta knowledge, executive knowledge

INTRODUCTION

This paper wants to challenge the usage of information and communication technology (ICT) in mathematics education, drawing on both Artificial Intelligence (AI) and software programming. Of course, this discussion can extend to all of science education in general. The essential question is whether ICT is a threat to the quality of mathematics education or it is an opportunity for that. Undoubtedly, ICT has found its way to every aspects of human life; however, it shouldn't have entered the educational systems without sufficient study.

In some cases, one assumes that ICT can control the education process entirely. It has grown out of the seed of electronic and computer progresses (Frederic Bourassa, 2011). When students surrender to ICT they might be skeptical of learning mathematics and, in their opinion, it could be enough if they just learned different mathematics software. Of course this willingness is a great advantage, as the educational system won't need to schedule how to teach this different mathematics software.

The paper tries to analyze the mathematics knowledge and to find a division in it before using ICT in mathematics education. Then it wants to propose a teaching method and the way of presenting topics so that students can trust systems of mathematics education because they have to spend a lot of time and energy learning mathematics. Teaching experiences indicate how this confidence fades away (Carmen M.Latterell, 2007).

The goal of the paper is a profound investigation of mathematics' topics' nature. It wants to propose which part of the knowledge of mathematics lends itself well to the facilities of ICT and which part of it may not be so.

Different modes of classroom teaching

In this section some common modes, which are widespread in universities and colleges, will be briefly reviewed.

The traditional teaching mode

The traditional teaching mode, in which instructors do not use ICT, has been being used for quite a long time. In spite of ICT progress, it is not wise to give up traditional mode entirely. In the same way, the invention of the printing industry has given the students an opportunity to have a lot of reference at their disposal with all the details of the topics but it could never take the instructor's place rather it came to be used as means of providing support for the students, that is, thanks to the printings, students attend the classes without overly worrying about complete note-taking.

The variety and abundance of books and libraries have not decreased the importance of traditional classes. In the new age, in spite of ICT's progress, the most popular educational system is still the traditional one. Because, a software package cannot simulate a seasoned teacher who has accumulated his art of teaching in the course of many years.

Some advantages of the traditional mode are as follows:

Instructors have been trained with this mode.

Instructors can make a direct connection with student.

The class is teacher-centered generally.

The students are separated from splendor of virtual environment and ICT.

Some shortcomings of the traditional education are as follows:

It is traditional.

There is a lack of experienced instructors who has teaching talent.

The class is teacher-centered.

The quality of a teacher-centered class is usually mentioned both as an advantage and a disadvantage because it can be very helpful in some cases yet it can also be detrimental in others. In the next sections, mathematics knowledge will be categorized to two parts, Meta knowledge and executive knowledge. Meta knowledge in most parts supports teacher-centered classes while executive knowledge deals with learner-centered classes (Samantha et al, 2009).

The modern teaching mode

The modern teaching mode, that is named e-education, tries to take maximum help from ICT. It wants to minimize human-to-human teaching by using software, hardware and internet network.

Some advantages of the modern education are as follows:

It is modern.

There is a possibility of distance teaching.

It can be learner-centered (Macdonald, 2009).

Some shortcomings of the modern education are as follows:

It is technology-centered.

It has unknown results for educational system.

Traditional and modern modes combined

The modes, mentioned in the previous section, are established in the education system. The traditional mode is the most well-established one. The modern mode, e-education, is used to teach in special conditions such as short time education, lack of experienced people and saving costs (Hennessy et al, 2010).

This paper does not intend to criticize the traditional or the modern education system. It basically seeks to find a way to the traditional and the modern combination modes (e.g. teaching by ICT). The traditional and the modern combination modes have entered educational system in two ways. First, they have been exercised personally by instructors; second, its industrial publicity has paved the way for its entrance into educational system. However, almost neither of them has been utilized professionally on scientifically sound bases.

It will not be suitable for one to sew clothes for the traditional education from ICT. A lot of works have been done to sew such clothes and have found some supporters because they are attractive and new, then they are forgotten because they are not utilized in the educational system (Romiszowski, 2004).

Using of PowerPoint files is the most popular combination mode. These files include sentences, formulas, figures, movies etc. They are prepared to be shown to students by instructors. In this way the topics can be shown very fast. Obviously increasing the speed of showing doesn't necessarily mean that the information is transferred to the students by instructor as fast. This method has minimally gotten help from ICT potentials. This may reduce instructor's mental and physical effort, in the class, but it is not a suitable option for serious teaching in its strict sense.

Of course it is very important that the students be taught faster than the past, because science progresses exponentially. Not only will not the problem be solved by showing the topics faster, but also the instructor's role will be decreased to an unskilled showman. The problems mentioned above and the subjects below made us consider some transformations in the traditional and modern combination mode.

ICT has a lot of potentials to be used in education.

There is a necessity to teach knowledge to students in short intervals.

The students are intensively attracted to ICT.

The next section of this paper wants to deliberate on mathematics knowledge. Because one has to know the road before they choose the kind of car and provisions for their trip.

MATHEMATICS KNOWLEDGE

Now there is a big question; with ICT attendance, is it necessary that whole mathematics knowledge be taught to the next generation? If the answer is not so clear, the question that follows would be which part of mathematics knowledge education needs to be changed basically?

For making this partition, we need to use progresses made in computer science and artificial intelligence, because we have to know which parts of mathematics education can be compatible with ICT. In this paper, knowledge is divided into two parts, Meta knowledge and executive knowledge. In the following sections these subjects will be elaborated on. Firstly we have to remember two definitions, because they are the foundation of computer science.

Algorithm:

A prescribed set of well defined rules or instructions for the solution of a problem, e.g. division algorithm, in a finite number of steps (Oxford Reference, 1990)

Heuristics:

A prescribed set of rules employing a self-learning approach to the solution of a problem, e.g. chess heuristics, in this case, unlike the Algorithm where the result is guaranteed you may or may not be able to solve problems (Oxford Reference, 1990)

Executive knowledge

Some part of Human knowledge that is named executive that can be transformed into algorithm or even heuristics. The following sentences are some examples to clarify the matter.

When one is able to do fundamental operations of arithmetic s/he has executive knowledge about them.

When one is able to calculate square root of a number s/he has executive knowledge about it.

When a football player kicks the ball carefully toward the goal then you can say that s/he has executive knowledge about it.

If a person knows English grammar completely then s/he can put the words in the order without any grammatical mistakes. They have the related executive knowledge.

The examples mentioned above show the abilities and some operations one can perform. At least in the above mentioned examples computers, by using algorithms and heuristics, can perform the operations faster and more accurately than human. So we must be more careful when we teach this part of knowledge, executive knowledge, because students might feel the time and energy that they spend on learning mathematics is wasted due to the fact that they are not only now but always will be far behind computers in mathematics (Heid, 1988).

Meta knowledge

Meta knowledge is knowledge about knowledge (Rich et al, 1991). This part of knowledge has not been able to be transformed into algorithms or even heuristics by artificial intelligence completely, and, it is not expected to happen by simulation of Meta knowledge, at least, in the near future. The following sentences are to provide examples to further clarify the matter.

We have twelve red apples. If we want to divide them among four persons equally. Which arithmetic operation will be needed?

In an isosceles right angled triangle, in which if we know the length of base how can we find the length of hypotenuse?

Which wing of the rival team could be more vulnerable for attacking?

What is the best sentence for a president, who wants to give speech at a present situation on a graduation day?

The following superiorities in executive knowledge will not help to solve any of the above mentioned problems.

To perform quickly fundamental operations of arithmetic.

To calculate square root of a number in less than a second with arbitrary approximation.

To shoot precisely and quickly.

To make thousands of correct sentences, from grammatical point of view, in a short time.

Mathematics educational system must focus on this part of knowledge, Meta knowledge. The structure of Meta knowledge does not suit up with computer science; therefore, it is necessary for the instructors be careful when they want to use ICT in their Meta knowledge classes.

Since the present educational system is based on facilities before ICT age, the instructors and students spend the major part of their time and energy, teaching and learning the executive knowledge. For example, in the differential equation lesson the instructors and their students spend their teaching and learning time on solving techniques- executive knowledge. It is not comparable with the time allocated to Meta knowledge part which exists in the differential equations, which creates certain tendency in students toward executive knowledge rather than Meta knowledge, while the process of education can be fruitful when the students pay more attention to Meta knowledge.

Example: Suppose the aim is to teach the following second order differential equation. Therefore, an instructor wants to teach four subjects to the students.

$$ay'' + by' + cy = g(x)$$

-The differential equation entity and the goal intention of solving that

In this case the instructor must teach the kind of category which includes these equations. S/he has to explain the differences and resemblances between the above mentioned equations and quadratic equations below (Boyce et al, 2005)

$$ax^2 + bx + c = 0.$$

For example, when you're solving the second order differential equation, you'll find some functions and when you solve, the quadratic equation, you'll find two numbers.

-The physical meaning of differential equation

The aim of this part of education, physical interpretation, is to model a phenomenon and produce the differential equation. For example, an instructor may illustrate the point, using the mass, spring and damper mechanism (See Figure 1) (Ahsan, 2005).

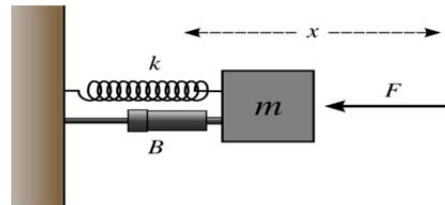

Figure 1: Mass, spring and damper mechanism

$$m\ddot{x} + B\dot{x} + kx = F$$

m , B and k are the mass and constant of damper and spring, respectively. If s/he discusses constant coefficients and point out that they can be variable in practice, then they can practically provide for a deeper understanding of the problem in the students mind.

-Uniqueness and existence of solution

An instructor can expand this part of the topics by further elaboration; of course, the intensity of their explanation will depend on the level of the class (Boyce, 2005).

-Solution techniques

In this part, the instructors want to give solution techniques most of which are algorithmic (Boyce, 2005). As we know, major part of the books, lectures and educational files are allocated to teaching the solution techniques. This might have been justifiable in the absence of ICT, and the students had to exercise different methods of the differential equations, because they had to develop a skill for solving the problems and finding final solutions. Out of the four above-mentioned subjects, only the fourth one is executive knowledge while the other three are Meta knowledge. Usually students focus just on the fourth one.

The presence of ICT, makes instructors rethink the teaching process, find it too slow, while it makes the students feel that mathematics education system keeps them in bondage, because they are wanted to do certainty the activities that their computers can do very much faster than them. The subjects 1, 2 and 3 do not make such impressions on the students. This paper does not propose to discard the learning of executive knowledge part in mathematics. The goal is to have mathematics Meta knowledge and executive knowledge be separated and treated differently, regarding the ICT use. In teaching executive knowledge, ICT can be utilized as mean of facilitating and speeding the teaching learning processes. However, as far as Meta knowledge concerned the optimal use of ICT can lead to evolved-lecture, to be explained in the later section.

The frontier between Meta and executive knowledge in mathematics

Although one can give a lot of examples for executive or Meta knowledge in isolation, generally speaking, there is not a clear-out boundary between them, That is, in some cases the frontier is fuzzy (see Figure 2).

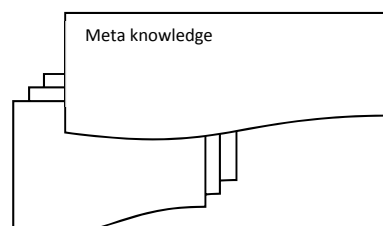

Figure 2: Meta and executive knowledge in mathematics

Example: In calculus, when the hyperbolic parabolic function (Larson, 2006),

$$z = f(x, y) = y^2 - x^2$$

is brought up by instructor, her /his goals are

To present a sample of two variables function (Meta knowledge).
 To sketch an example of two variables function (executive knowledge).
 To introduce a new point, saddle point, on the surface (Meta knowledge).
 To raise the students ability in three dimensional imagination (Meta knowledge).
 In this case, if s/he wants to separate executive knowledge from Meta knowledge it, might impair the students learning process.

Example: When an instructor wants to prove the theorem about exact differential equation

$$M(x,y)dx + N(x,y)dy = 0$$

S/he simultaneously teaches the solution technique; while proving the theorem is a part of Meta knowledge and the solution technique is a part of executive knowledge (Boyce, 2005).

Therefore, if a topic falls into the frontier between Meta knowledge and executive knowledge, it is suggested that it be categorized in Meta knowledge part.

THE INSTRUCTOR

The fact that there were just a few good mathematic instructors during our college years can be a good reason proving that there are not a lot of good instructors to teach. However, you can find a lot of researchers in mathematics. The traditional educational style has tried to resolve this discrepancy by books. That means a good instructor has tried to write a book in her or his specialized field so that her/ his experiences would be comprehended by another instructor or students. Nonetheless, by studying different kinds of books on a special topic, it could be understood that the writer had mastered some parts better in comparison with other parts. Therefore, if the students want to understand a topic profoundly, a part from their class lectures, they have to study about it in different works. Maybe the best commentary of a topic, especially in mathematics, may belong to certain at a particular instructor from a university. Now the following questions are mooted:

Can all of the students, who are interested in the topic, benefit from the instructor?

Is making the instructor write a book about a whole topic the only possible way?

How can one find such instructors?

Will the preparation of a video and a documentary from an instructor's class and their presentation in the internet, be suitable?

Can we use social networks for finding the instructor?

How can an instructor use such instructors' methods in her or his class?

To answer the questions above, in the next part, a person will be suggested as the class director – rather than instructor- to manage the class.

The class director as a substitute for an instructor

This section wants to propose that a class director substitute an instructor in the presence of ICT. The class director must not only have mastery over the whole topics of a lesson but also s/he has to manage the following items.

To manage the syllabus.

To find the best innovated way of instruction in a specific topic.

To assemble and to update the resources.

To be well informed about the ways of presentation.

To control the amount of information the students are provided at a given time.

Since the experiences of an instructor are accumulated in a long time, the educational system cannot possibly train them in a short time. However, the education system can train a class director in a short time with ever higher efficiency. Of course, some of the class's directors will be specialize in teaching certain topics. The following parts will extend the mentioned duties of the class directors.

To manage the syllabus

The syllabus will be categorized into two parts, Meta knowledge and executive knowledge, by the director of a class. To carry out such division, the instructor will have to have enough information about the topics, as well as the capabilities of different mathematics software. Only in this way will the director have the required ability to treat the two categories of knowledge differently that is through knowing different mathematics software comprehensively. In the executive knowledge this ability has particular significance, regarding (Wiwatanapataphee et al, 2010).

The division is done in ordinary differential equations in Shabestar Branch, Islamic Azad University practically, some details of which are attached as an appendix.

To find the best innovated way of instruction in a specific topic

Finding the best innovated way of instruction in a specific topic area can be a matter of opinion and may depend on personal inclination or judgment and, in some cases, the class directors can find certain unique techniques in their education process. For example, the limit definition is a very difficult topic in calculus and there is no tangible interpretation in the calculus books. But the class director can find a tangible interpretation in limit definition and pliers mechanism (Hosseingholizadeh et al, 2011). For another example s/he can choose some video from websites (see <http://ocw.mit.edu/courses/>) and use that in her or his class directly etc. Then, s/he can select the one that has worked best for her/his next semester class.

To assemble and to update the resources

To assemble and to update the resources in a good manner is important to make optimal use of time and energy in teaching and learning processes, and this paper proposes to maximize the usage of internet, websites and different software. Of course, the optimal point is when instructors in the universities promote their relationships and share their lectures, videos and educational files. For example, in the field of Meta knowledge if the class director knows that some parts of a lesson has been taught by a professor in a very good manner and its video or lecture is available, then her/his documents can be used in the class directly. In the field of executive knowledge the class director has to know about different mathematics software, and web sites, so that s/he can seek help with the calculation of long mathematical expressions and to sketch some functions' graphs etc.

When the class director wants to assemble her/his class lectures, they have to prepare a lot of useful links; yet the lecture which has been prepared by the class director may not mature enough. A lecture will mature, when the number of useful links is grown and the volume of primary lectures has shrunk by crossing out some topics and substituting them with the links. This paper calls such a lecture an evolved-lecture. We propose that the volume of the lectures be reduced down to a level which approaches the ideal sample in the worldwide educational viewpoint. These lectures will be the most evolved ones.

Considering the nature of mathematics, it will be possible to generate such evolved-lectures. In this way mathematics' education can make a progress, on the basis of ICT, by generating evolved-lectures.

The ways of presentation

The educational procedure, mathematics education, is a linear process. When a student commences to read a mathematics book, s/he is following the author's thinking line. The linear education process is followed clearly by the students, when they attend the class. In the traditional education, knowledge has been transferred to students in a sorted package of written, oral and body languages of the instructors simultaneously. Therefore, the students cannot move back or forward. So in a complex human relationship, the instructor's line of thinking is followed by the students.

When we use ICT, not only can the students move in any direction in the topic, but also their minds might be strayed by ICT distraction. The class director will need to be educated and trained about the manner of setting and presenting the topics, because the linearity of education process must be maintained (Stokes, 2001).

To control the amount of information the students are provided at a given time

In the traditional education, the amount of information the students are provided at a given time has been controlled automatically. The information has been transferred in an acceptable time by written, oral and body languages of the instructors, so there is enough time for the students to receive the matter. Now if you let the class director be armed with powerful information systems like computer, internet and different software, the control won't happen automatically. Therefore, the class directors should be trained in this case, Meta Knowledge part especially, so that they can control the teaching speed by debating, questioning, answering etc (Means et al, 2010).

One of the principal goals is to transfer Meta knowledge faster and more favorably. As it has already been pointed out, the educational system cannot reach this goal by increasing the speed of teaching, nevertheless, it can save time by categorizing Meta knowledge from executive knowledge and making changes in the teaching method of both knowledge types through using ICT.

PRACTICAL RESULTS

The mooted method has been executed four semesters, two years, in teaching Ordinary Differential Equation class. The students, who took the course, were from different field of engineering like electronic, mechanic, nutrition, civil, computer. The following table shows that the method is not disappointed (Table 1).

Total	Proponents	Opponents	In a daze	Neutral
552	315	98	62	77

Table 1: The students' verdict about the method

Incidentally a survey between proponents and opponents, 413 students, show most of them interested to executive knowledge part of Ordinary Differential Equation (Table 2).

The students' Field	The students' Number	Purely interested to Meta knowledge	Purely interested to executive knowledge	Interested to both part of knowledge
Electronic	92	28	51	13
Mechanic	67	30	26	11
Nutrition	76	18	39	19
Civil	109	16	64	29
Computer	69	10	32	27
Total	413	102	212	99
Percent	100%	24.7%	51%	23.9%

Table 2: The students' verdict about each parts of knowledge

CONCLUSION

Information and communication technology was born by mathematics researches therefore, it is very important that mathematics educational system pays attention when it wants to use ICT because it may be possible for the educational system to be captured in a vicious circle. Investigating lesson syllabuses and the potential of ICT more thoroughly has a higher priority than equipping the class with ICT. That is to say it will be better off if ICT can provide the mathematics education system's recommendations for teaching. That has been the main focus of the paper. Consequently it proposes categorizing mathematics knowledge into two parts, Meta knowledge and executive knowledge, and introduces the class director, who is responsible for the production of the evolved-lecture. Of course, both the duties of the class director and producing the evolved-lecture have a lot of details for future researches.

ACKNOWLEDGEMENT

This study was funded by Shabestar Branch, Islamic Azad University, Iran.

REFERENCES

- Ahsan, Z. (2005). Differential equations and their applications, second edition. Prentice Hall of India Private Limited, New Delhi. 244-254.
- Boyce, W. DiPrima, R. (2005). Elementary differential and boundary value problem, eighth edition. Willey International edition. 135-192, 94-98.
- Carmen, M. Latterell. (2007). Today's mathematics students. The Montana mathematics enthusiast, 4, 1, 66-72.
- Frederic, B. (2011). Measuring trends in ICT trade: From HS2002 to HS2007/ICT product definition. United Nations department of economic and social affairs statistics division. Expert group meeting on international economic and social classifications, New York, 18-20 May.
- Heid, M. K. (1988). Resequencing skills and concepts in applied calculus using the computer as a tool. Journal for Research in Mathematics Education, 19(1), 3-25.
- Hennessy, S. Onguko, B. Harrison, D. Enos Kiforo Ang'ondi, Namalefe, Naseem, S. and Wamakote, L. (2010). Developing the Use of Information and Communication Technology to Enhance Teaching and Learning in East African Schools: Review of the Literature. Faculty of Education University of Cambridge.
- Hosseingholizadeh, R. Salimi, A. (2011). Limit definition and pliers mechanism. Literacy Information and Computer Education Journal. 2, 2.
- Larson, R. Edwards, B. (2006). Multivariable calculus, Ninth edition, International edition. Brooks/Cole Cengage learning. 815-818.
- Macdonald, R. (2009). Supporting learner-centered ICT integration: The influence of collaborative and needs-based professional development. Journal of Technology and Teacher Education, 17, 3.
- Means, B. Toyama, Y. Murphy, R. Bakia, M. Lones, K. (2010). Evaluation of evidence-based practices in online learning: a meta-analysis and review of online learning studies. U.S. Department of Education Office of Planning, Evaluation, and Policy Development Policy and Program Studies Service.
- Oxford Reference. (1990). Dictionary of computing. Oxford University Press.
- Rich, E. Knight, K. (1991). Artificial intelligence, Second edition. McGraw-Hill, Inc. 189.
- Romiszowski, A.J. (2004). How's the e-learning baby? Factors leading to success or failure of an educational technology innovation. Educational Technology, 44, 1, 5-27.
- Samantha C. Bates Pains. (2009). Student-Centered instruction in a theoretical statistics course. Journal of Statistics Education, 17, 3.

- Stokes, S. (2001). Visual literacy in teaching and learning: a literature perspective. *Electronic Journal for the Integration of Technology in Education*, 1, 1.
- Wiwatanapataphree, B. Noinang, s. Wu, Y. Nuntadilok, B. (2010). An integrated Powerpoint-Maple based teaching-learning model for multivariate integral calculus. *International Electronic Journal of Mathematics Education*, 5, 1.

APPENDIX

Example: This example separates the syllabus of ordinary differential equations (ODE) in two parts, Meta and executive knowledge. The Frontier between Meta and executive knowledge is lodged in the Meta knowledge part.

Part one (Meta knowledge):

- To introduce the kinds of differential equations and intend to solve them.
- Family of curves and orthogonal trajectories.
- The physical methods.
- Unique existence theorem of the first-order differential equations.
- Nonlinear first-order differential equations in the form of $M(x,y)dx + N(x,y)dy = 0$.
- First-order differential equations applications examples.
- Second-order differential equations.
- Linear second differential equations and unique existence theorem of them.
- Linearly independent solutions of homogeneous linear second-order differential equations (linear combination, linear independence and Wronskian).
- Complementary and particular solution of nonhomogeneous linear second-order differential equations and a relation between them.
- Practical examples of second-order differential equations.
- Power series review.
- To propose using power series to solve the second-order differential equations when their coefficients are function from the independent variable.
- Ordinary point and its theorem.
- Regular singular point and its theorem.
- Irregular singular point.
- To introduce the integral transform and Laplace transform for sample of integral transforms.
- Piecewise continuous functions and their Laplace transform and theorems about them.
- Relation between a function Laplace transform and its derivative Laplace transform.
- Step function and the theorem about inverse transformations.
- Impulse function.
- Examples of linearly first-order systems applications.
- To remember the matrix topics.
- Principle theorem of linear first-order systems.

Part two (Executive knowledge):

- How can you solve linear first-order differential equations?
- Separable differential equations and its solutions?
- How can you solve Bernoulli differential equation?
- Riccati equation and its solution?
- How can you solve the exact differential equations?
- How can you solve homogeneous equations?
- What is an integrating factor? And how can you use it?
- How can you find second linear independent solution of a second-order differential equation (reduction of order)?
- How can you solve a linear second-order homogeneous with constant coefficients?
- How can you solve a linear second-order nonhomogeneous with constant coefficients (undetermined coefficients method)?
- What is variation of parameters method?
- How can you use power series for solving second-order differential equations at neighborhood of an ordinary point?
- How can you solve Euler differential equation?
- How can you solve differential equations at neighborhood of regular singular point?
- How can you solve Bessel differential equation?
- How can you find Laplace transform of important functions?

How can you solve initial value problem by Laplace transform?
How can you evaluate piecewise continuous functions?
How can you solve a differential equation with piecewise continuous function?
How can you solve linear first-order differential equation systems?

MATHEMATICS TEACHER CANDIDATES' METAPHORS ABOUT THE CONCEPT OF "MATHEMATICS"

Ahmet ERDOĞAN

Department of Secondary Mathematics Education, Ahmet Kelesoglu Education Faculty,
Necmettin Erbakan University, Konya, Turkey
aerdogan@konya.edu.tr

Derya Ozlem YAZLIK

Institute of science and technology, Selcuk University, Konya, Turkey
deryaozlemyazlik@mynet.com

Cengiz ERDIK

Department of Primary Mathematics Education, Alanya Education Faculty,
Akdeniz University, Antalya, Turkey
cengizerdik@akdeniz.edu.tr

ABSTRACT: The main purpose of this study was to research mathematics teacher candidates' perceptions about the concept of "mathematics" through the use of metaphors. The research is conducted during 2012-2013 academic year, on a group of 111 mathematics teacher candidates at Necmettin Erbakan University. Of the participants 76 (68%) were female and 35 (32 %) were male. To collect the research data, each participant was asked to complete the prompt "*Mathematic is like . . . because . . .*" The content analysis technique was used in this study in order to evaluate the data collected. As a result of the data analysis, it was found that 67 valid metaphors were developed by the participants. Out of 67 metaphors, 9 were related to the living beings (3 human, 2 animal, 3 plant and 1 virus) while the rest 58 were related to the inanimate (such as, see, building and tree).

Key words: Metaphors about the concept of "mathematic"; mathematics teacher candidates; attitudes towards mathematics

INTRODUCTION

Traditionally, a metaphor is defined as a poetical image and a rhetorical tool which is limited to use in literature. Metaphor was defined as an embellishment or a style of speaking in the past (Lakoff and Johnson, 2003). Metaphor is not a mere embellishment, it is the basic means by which abstract thought is made possible (Lakoff & Nunez, 2000). Metaphor is considered as the strongest device for an individual to comprehend and explain a hypothetical or an abstract, complex fact in a high level (Saban, Koçbeker & Saban, 2006). A metaphor is actually a way of understanding one reality by means of another reality (Romanyshyn, 2001). Metaphors are usually used for the purpose of correlating something unknown or barely known with something better known (Kovecses, 2010). Additionally, metaphors give opportunities for comparing two things, drawing attention to the similarities between two things and explaining one thing in terms of another (Saban, 2004).

Metaphors have many advantages for educators and learners. If our conceptual system and thought processes are largely metaphorical, analyzing metaphorical thinking of people is a good way to understand what happens in their mind (Lakoff & Johnson, 2003). In recent years, there were many studies conducted to investigate the metaphors about "teaching", "learning" and "teacher" concepts (Carlson, 2001; Guerrero and Villamil, 2002; Yob, 2003; Saban, 2004; Saban, Koçbeker & Saban, 2006; Leavy, McSorley & Bote, 2007; Saban, 2009; Alger, 2009; Güler, Öçal and Akgün, 2011).

According to Ernest (2010), mathematics is a complex system. Mathematics truly has many components. Indeed, as is acknowledged, the very term "mathematics" is highly indefinite. Mathematics is an organised body of knowledge, a practice engaged in by mathematicians, a school subject, a cultural object of many meanings, and a language and box of conceptual tools used variously in many different practices. Its name alone (mathematics) is ambiguous because it is a plural word that is treated as naming a single entity.

Mathematics is a mysterious subject, and a number of myths are associated with mathematics. These myths include commonly expressed views including: "mathematics is only for clever people and male"; "your father is a mathematics teacher so you must be good in mathematics too" (Lim and Ernest, 1998). In the some researches, it was concluded that mathematics was about number and computation, a boring, difficult and dislike course (Raymond, 1997; Picker and Berry, 2000; Rock and Shaw, 2000; Schinck et al., 2008; Uçar et. al, 2010; Kılıç,

2011). Furthermore most of these views about mathematics are negative. Such negative views are common and seem to be present in many countries (Lim and Ernest, 1998).

Students have various beliefs about mathematics. These beliefs are linked to interpretations of the role mathematics plays in their lives, both within and outside of school. But determining student beliefs is a difficult undertaking. Metaphor provides a means of unpacking the beliefs that students have about mathematics. (Schinck et al., 2008). When literature is analyzed in terms of metaphor, there are some studies had been conducted on metaphorical images of specific content like mathematics (Lim and Ernest, 1998; Lim, 1999; Noyes, 2006; Sterenberg, 2008; Schinck et al., 2008; Reeder, Utley & Cassel, 2009; Kılıç, 2011).

Saban (2004) argued that individuals who come to faculties of education to become teachers bring many attitudes towards many concepts with themselves like teacher and learning depending on their experiences during their primary and secondary education. From this perspective, it is important to reveal and discuss mathematics teacher candidates' concept of "mathematics". Therefore, this study was conducted to reveal perceptions of mathematics teacher candidates with regard to the concept of "mathematics".

The aim of this study is to examine mathematics teacher candidates' perceptions with regard to mathematic through metaphor analysis. With this aim in mind, answers for the following questions were sought:

1. What kind of metaphors do mathematics teacher candidates use to explain the concept of mathematics?
2. In what category do mathematics teacher candidates collect the metaphors they use to explain the concept of mathematics?

METHODS

Participants

A total of 111 mathematics teacher candidates at Ahmet Keleşoğlu Faculty of Education, Necmettin Erbakan University took part in this study. Content analysis, method which is one of the qualitative research methods, was employed in this study. The participants volunteered to take part in the study. 76 (68%) of the participants were female and 35 (32%) were male and their ages ranged between 18 and 22 (mean 20.2). This study was carried out in the fall semester of 2012-2013 academic years.

Data Collection

To determine mathematics teacher candidates' metaphors with regard to "mathematics", cards on which has the sentence "*Mathematics is like.....because*" is written were handed out to the participants and they were asked to complete this statement using only one metaphor and explaining the reason of their metaphor. At the beginning of the study, the participants were explained what the concepts of "metaphor" meant and why it was used with examples and they were given 20-30 minutes to write an appropriate metaphor and the reason why they chose that particular metaphor. The time allocated for the students to write the metaphor was considered to be enough as the aim of this study was to make mathematics teacher candidates focus on the very first metaphor that occurred to their mind. The answers students provided for the sentence written on the cards- which is mentioned above- formed the basic source of data for our study.

Data Analysis

When analyzing the metaphors mathematics teacher candidates developed, first appropriate and in appropriate metaphors were determined. A total of 10 metaphor card in which more than one metaphors were determined or metaphors without relation between the target and source were determined, were left out of assessment. A list of metaphor was formed by coding the remaining metaphors.

Second, the sources of the metaphors mathematics teacher candidates developed with regard to mathematics were read carefully and they were categorized. When categories were formed, the common characteristics of teacher candidates with regard to the concepts of "mathematics" were taken into consideration.

Third, the study was validated. Yıldırım and Şimşek (2005) state that detailed reporting of how data and results were obtained is a very important criterion for validity in qualitative research. In line with this, data collection process and analysis process were explained in detail. To ensure reliability of the study, data obtained was analyzed first by the researcher and then by a professor who is an expert in this field of study and metaphors and categories were determined. The analyses carried out by the researchers and expert professor were compared and the number of metaphors and categories that overlapped and did not overlap were determined. The formula (Reliability= the number of overlapping items (metaphors) / (the number of overlapping + not overlapping ones)) developed by Miles and Huberman (1994) was used and reliability level was found to be %92. According to Miles and Huberman, values higher than 90% and over obtained using this formula are regarded to be adequate for reliability.

After metaphors and categories representing them are given are finalized, data were submitted to SPSS software and percentiles and frequencies were calculated as a last step.

RESULTS AND FINDINGS

In this section of the study, results with regard to metaphors by mathematics teacher candidates about the concept of "mathematics" are presented in tables and they were analyzed and interpreted under subheadings determined based on research questions.

1. With what kind of metaphors do mathematics teacher candidates explain the concept of mathematics?

As a result of the study, 67 metaphors in total were found to be related to the concept of "mathematics". 49 of these metaphors were provided by only one teacher candidate and the remaining 18 were provided by a number of teacher candidates ranging from 2 to 9. Top 5 metaphors were found to be: water (9 teacher candidates, 8.1%), puzzle (7 teacher candidates, 6.3%), ocean (5 teacher candidates, 4.5%), sea (4 teacher candidates, 3.6%), and riddle (4 teacher candidates, 3.6%). Among 9 metaphors that were linked with living beings, 3 were human, another 3 were plant, 2 were animal and one was a virus. 46 were tangible, and 12 were intangible objects among the 58 metaphors that were linked with non-living beings.

In Table 1, a list of metaphors developed by mathematics teacher candidates and the number and percentage of teacher candidates representing each metaphor are given.

Table 1. Metaphors Developed Regarding The Concept of "Mathematics" and The Number and Percentage of Teacher Candidates Representing Them.

No.	Metaphor name	Frequency (f)	Percentage (%)	No.	Metaphor name	Frequency (f)	Percentage (%)
1	Water	9	8.1	35	Queen	1	0.9
2	Crossword	7	6.3	36	Tower	1	0.9
3	Ocean	5	4.5	37	Well	1	0.9
4	Sea	4	3.6	38	Love	1	0.9
5	Puzzle	4	3.6	39	Matryoshka doll	1	0.9
6	Tree	3	2.7	40	Letter	1	0.9
7	Space	3	2.7	41	Marsh	1	0.9
8	Language	3	2.7	42	Building foundation	1	0.9
9	Building	3	2.7	43	Aids	1	0.9
10	Game	3	2.7	44	Garden	1	0.9
11	Lantern	3	2.7	45	Money	1	0.9
12	Life	3	2.7	46	Pizza	1	0.9
13	Maze	2	1.8	47	Compass	1	0.9
14	River	2	1.8	48	Thorny rose	1	0.9
15	Oxygen	2	1.8	49	Milk way	1	0.9
16	Infinity	2	1.8	50	Ivy	1	0.9
17	Dominos	2	1.8	51	Darling	1	0.9
18	Cat	2	1.8	52	Black	1	0.9
19	Instrument	1	0.9	53	Chocolate wafers	1	0.9
20	Universe	1	0.9	54	Mind game	1	0.9

21	Clothes	1	0.9	55	Salt water	1	0.9
22	Sky	1	0.9	56	Cliff	1	0.9
23	Soccer game	1	0.9	57	Great plane	1	0.9
24	Illness	1	0.9	58	Omani	1	0.9
25	Lion	1	0.9	59	Gap	1	0.9
26	Light	1	0.9	60	Virus	1	0.9
27	Drug	1	0.9	61	Vitamins	1	0.9
28	Desk	1	0.9	62	Jigsaw	1	0.9
29	Human	1	0.9	63	Vita	1	0.9
30	İstanbul	1	0.9	64	Life source	1	0.9
31	Destiny	1	0.9	65	Star cluster	1	0.9
32	Dark caves	1	0.9	66	Brain teaser	1	0.9
33	Habit	1	0.9	67	Chain ring	1	0.9
34	Deadlock	1	0.9	Total		111	100

2. In what category do mathematics teacher candidates collect the metaphors they use to explain the concept of mathematics?

However, 60 of the 67 metaphors were under a single category while 7 metaphors were under 2 or 3 categories. For instance, the "ocean" metaphor developed by teacher candidate 54 was under *mathematics as a limitless figure* category, while the "ocean" metaphor developed by teacher candidate 28 took place under the *mathematics as a foundation figure for other fields of science*. Classification of metaphors that were developed by teacher candidates according to their categories and the number of teachers representing them are given in Table 2.

Table 2. Classification of Metaphors Developed by Teacher Candidates According to Categories and The Number and Percentage of Teacher Candidates Representing Them.

Categories		Number of metaphors	Number of teacher candidates	Percentage of teacher candidates
1	Mathematics as a limitless figure	14	22	19.8
2	Mathematics as an interconnected figure	11	15	13.5
3	Mathematics as a basic need figure	5	14	12.6
4	Mathematics as a fun figure	6	10	9.0
5	Mathematics as a cumulative figure	7	8	7.2
6	Mathematics as an indispensable figure	8	8	7.2
7	Mathematics as a foundation for other sciences	7	8	7.2
8	Mathematics as a hard-to understand figure.	5	5	4.5
9	Mathematics as a guiding figure.	3	5	4.5
10	Mathematics as a universal language.	2	4	3.6

11	Mathematics as a figure that requires continuity.	3	4	3.6
12	Mathematics as a figure that is yet to be solved.	2	3	2.7
13	Mathematics as a mind-developing figure.	3	3	2.7
14	Mathematics as a figure with a single correct answer.	1	2	1.8

Category 1: Mathematics as a limitless figure

In total, there are 14 metaphors represented by 22 (19.8%) teacher candidates under this category. These metaphors are “ocean” (3), “sea” (4), “space” (3), “infinity” (2), “sky” (1), “vita” (1), “omani” (1), “well” (1), “great plane” (1), “gap” (1), “black” (1), “universe” (1), “star cluster” (1), “cliff” (1). When the metaphors were analyzed, it was found that prospective teachers who developed these metaphors perceive mathematics as limitless. These teacher candidates emphasized that subjects of mathematics are infinite and that there are more to discover as new discoveries in mathematics are made. Quotes from teacher candidates' who came up with the category *mathematics as a limitless figure* are as follows:

"Mathematics is like the star clusters in space because it as limitless as they are. Just like stars, there will be further discoveries as we discover stars and you work on finding another while you have discovered one" (teacher candidate 23, male).

"Mathematics is like the color black, because, to me, black represents infinity and never endlessness. So does mathematics; it is infinite" (teacher candidate 101, female).

"Mathematics is like infinity. Just like it, it has no limit. It makes you think that, once you have achieved something, you find yourself at the very beginning and so it never ends with mathematics" (teacher candidate 4, female).

"Mathematics is like space because it contains many galaxies, stars, planets and many objects that we are yet to discover and learn. You can never say, okay, that is it, it is over, always new subjects come up; they are infinite" (teacher candidate 20, female).

"Mathematics is like the ocean in a way that when the ocean is observed from land, it seems infinite and so it is how mathematics seems when studying a subject; problems, and theorems related to that subject are so broad in scope that we are able to produce hundreds of problems within merely one problem" (teacher candidate 58, female).

Category 2: Mathematics as an interconnected figure

In total, there are 11 metaphors represented by 15 (13.5%) teacher candidates under this category. These metaphors are “puzzle” (4), “tree” (2), “milk way” (1), “destiny” (1), “game” (1), “matryoshka doll” (1), “chain ring” (1), “building” (1), “life” (1), “crossword” (1), “dominos” (1). When the metaphors were analyzed, it was found that the teacher candidates who came up with these metaphors perceived mathematics as an interconnected and interrelating figure. These teacher candidates pointed out that the content of mathematics are interrelated and that one could not be formed without the other and that through searching for these correlations it is possible to achieve results. Quotes from teacher candidates' who came up with the category *mathematics as an interconnected figure* are as follows:

"Mathematics is like the Milky Way. When we consider that all planets in the Milky Way are connected to one another we can see that mathematics is interrelated within itself as a whole. In the Milky Way, elimination of a planet may destroy everything, similarly in mathematics; a vanishing expression may destroy everything" (teacher candidate 7, male).

"Mathematics is like a tree in a way that the roots, trunk, branches and leaves of a tree are all interconnected. In mathematics, the roots of a tree are definitions. The trunk contains demonstrations. Just like branching in a tree the theorems are interconnected and finally the leaves show the results" (teacher candidate 75, female).

"Mathematics is like a puzzle. When one of the pieces of the puzzle is missing, the puzzle picture cannot be completed and similarly, in mathematics, when a piece of information is missing, it is not possible to achieve results." (teacher candidate 99, female).

"Mathematic is like life. Every year, every month and every day of life is connected to each other. A person cannot run without first learning to walk, one cannot perform an operation without learning about numbers first and if one does not know how to perform an operation then one cannot solve a problem" (teacher candidate 17, female).

Category 3: Mathematics as a basic need figure

In total, there are 5 metaphors represented by 14 (12.6%) teacher candidates under this category. These metaphors are “water” (9), “oxygen” (2), “life source” (1), “money” (1), “clothes” (1). When the metaphors were analyzed, it was found that teacher candidates who came up with these metaphors perceived mathematics as a basic need to continue living. These teacher candidates pointed out that life cannot be sustained without mathematics just like one cannot survive without air and water. Quotes from teacher candidates' who came up with the category *mathematics as a basic need figure* are as follows:

"Mathematics is like water. Life cannot exist without water and so without mathematics. This is because nature is based on a certain balance and people need mathematics in order to understand this balance." (teacher candidate 26, female).

"Mathematics is like money because money always exists in our lives and it is indispensable. When we consider that mathematics is a science which exists for fulfilling human needs and that human needs will always exist and we cannot live without money, we cannot live without mathematics" (teacher candidate 32, female).

"Mathematics is like a source of life because we face it at every moment of our lives. Mathematics is involved with every discovery that carries utmost significance for people." (teacher candidate 59, female).

Category 4: Mathematics as a fun figure

In total, there are 6 metaphors represented by 10 (9%) teacher candidates under this category. These metaphors are “crossword” (4), “game” (2), “mind game” (1), “pizza” (1), “İstanbul” (1), “soccer game” (1). When the metaphors were analyzed, it was found that teacher candidates who came up with these metaphors perceived mathematics as a fun figure. These teacher candidates pointed out that it fun to engage in mathematics and that they it gives them joy. Quotes from teacher candidates' who came up with the category *mathematics as a fun figure* are as follows:

"Mathematics is like a game because engaging in mathematics and learning new things is pleasurable just like playing a game" (teacher candidate 38, male).

"Mathematics is like a soccer game. When people enjoy it while playing with a ball on the field, it is just as much fun to deal with theorems and numbers in mathematics." (teacher candidate 11, male).

"Mathematics is like crossword. Trying to solve mathematical problems gives me just as much pleasure to solve crossword." (teacher candidate 90, female).

"Mathematics is like Istanbul. It is a great pleasure once you have understood it; just like wandering Istiklal Street. Once you have solved a problem you view life from above, just like going on top of the Fortress of Rumeli and watch the view of Bosphorus. Sometimes one cannot figure out a theorem and get stuck with it, just like getting stuck in traffic at the E5 highway. Regardless, one becomes happy with mathematics just like one feels in Istanbul." (teacher candidate 72, male).

Category 5: Mathematics as a cumulative figure

In total, there are 7 metaphors represented by 8 (7.2%) teacher candidates under this category. These metaphors are “building” (2), “dominos” (1), “jigsaw” (1), “tower” (1), “ocean” (1), “desk” (1), “dark caves” (1). When the metaphors were analyzed, it was found that teacher candidates who came up with these metaphors perceived mathematics as a cumulative figure. These teacher candidates pointed out that mathematics constitutes an accumulation of heaps of information. Quotes from teacher candidates' who came up with the category *mathematics as a cumulative figure* are as follows:

"Mathematics is like the ocean. The ocean consists of tiny water drops and so mathematics consists of an accumulation of information clusters as a body" (teacher candidate 15, male).

"Mathematics is like a desk at primary school. Somebody writes down on this desk and in the following years every person who sits there makes other additions. Mathematics is just like that." (teacher candidate 21, male).

"Mathematics is like a building. A building is constructed by placing bricks on top of each other and so is mathematics, a science formed by stacking heaps of information." (teacher candidate 69, female).

Category 6: Mathematics as an indispensable figure.

In total, there are 8 metaphors represented by 8 (7.2%) teacher candidates under this category. These metaphors are “virus” (1), “ivy” (1), “life” (1), “salt water” (1), “marsh” (1), “Chocolate wafers” (1), “habit” (1), “illness” (1). When the metaphors were analyzed, it was found that teacher candidates who came up with these metaphors perceived mathematics as an addictive and indispensable figure. These teacher candidates emphasized that they were not able to break off of mathematics once they have studied it and that they would like to continue dealing with it. Quotes from teacher candidates' who came up with the category *mathematics as an indispensable figure* are as follows:

"Mathematics is like a virus. Mathematics is like how an addictive virus without a working cure does not leave the body." (teacher candidate 12, female).

"Mathematics is like a marsh. Once you have entered a marsh, you cannot get out and once you have engaged in mathematics, you cannot leave it." (teacher candidate 110, male).

"Mathematics is like ivy. Once you have made contact it creeps up on you and neither can you break off of it nor can it break off of you." (teacher candidate 34, female).

Category 7: Mathematics as a foundation for other sciences

In total, there are 7 metaphors represented by 8 (7.2%) teacher candidates under this category. These metaphors are "river" (2), "tree" (1), "building foundation" (1), "ocean" (1), "lion" (1), "queen" (1), "garden" (1). When the metaphors were analyzed, it was seen that teacher candidates who came up with these metaphors perceived mathematics as the foundation for other fields of science. These teacher candidates pointed out those other fields of science were nurtured by mathematics and that further advances in those fields could only be made through mathematics. Quotes from teacher candidates' who came up with the category *mathematics as a foundation for other science* are as follows:

"Mathematics is like a queen. It is the outset for all fields of science. We cannot consider any science without mathematics." (teacher candidate 98, female).

"Mathematics is like a lion. Just as the lion is the king of the forest, mathematics is the dominator of other fields of science." (teacher candidate 40, female).

"Mathematics is like the foundation of a building. If we consider other fields of science as buildings, mathematics would be their foundation. Other fields of science are able to stand by means of it." (teacher candidate 67, male).

Category 8: Mathematics as a hard-to-understand figure

In total, there are 5 metaphors represented by 5 (4.5%) teacher candidates under this category. These metaphors are "darling" (1), "thorny rose" (1), "deadlock" (1), "human" (1), "life" (1). When the metaphors were analyzed, it was found that teacher candidates who came up with these metaphors perceived mathematics as a hard-to-understand figure. These teacher candidates pointed out that, to them, mathematics were complicated and hard to understand. Quotes from teacher candidates' who came up with the category *mathematics as a hard-to-understand figure* are as follows:

"Mathematics is like a thorny rose. It is difficult to handle a thorny rose just as understanding mathematics." (teacher candidate 5, male).

"Mathematics is like a darling. It has always been difficult for me to figure out both." (teacher candidate 27, male).

"Mathematics is like a deadlock. It is either difficult or impossible to untie a Gordian knot, just as it is with mathematics." (teacher candidate 13, female).

Category 9: Mathematics as a guiding figure

In total, there are 3 metaphors represented by 5 (4.5%) teacher candidates under this category. These metaphors are "lantern" (3), "compass" (1), "light" (1). When the metaphors were analyzed, it was found that teacher candidates who came up with these metaphors perceived mathematics as a guiding figure. These teacher candidates see mathematics as a guiding tool that would help understand nature and ease life. Quotes from teacher candidates' who came up with the category *mathematics as a guiding figure* are as follows:

"Mathematics is like light. Light leads others in its environment. Mathematics, similarly to light, guides us to understand nature and helps us make advances in technology." (teacher candidate 53, female).

"Mathematics is like a compass. The route that mathematics leads us is the reference point for us to figure out the whole universe." (teacher candidate 73, male).

"Mathematics is like a lantern. It is a tool that sometimes a physicist, a chemist or an engineer uses to find his/her way." (teacher candidate 41, male).

Category 10: Mathematics as a universal language

In total, there are 2 metaphors represented by 4 (3.6%) teacher candidates under this category. These metaphors are "language" (3), "letter" (1). When the metaphors were analyzed, it was found that teacher candidates who came up with these metaphors perceived mathematics as a language. These teacher candidates stated that mathematics was a language like Turkish, or Persian and that it was a common language spoken by the whole world. Quotes from teacher candidates' who came up with the category *mathematics as a universal language* are as follows:

"Mathematics is like language, since it contains symbols that are able to express themselves. Therefore it is a common language that anyone can speak, a universal language." (teacher candidate 44, male).

"Mathematics is like a letter. It is such a letter that it tells you everything with its symbols and numbers so wherever in the world you sent it they can read it and understand it." (teacher candidate 1, female).

Category 11: Mathematics as a figure that requires continuity

In total, there are 3 metaphors represented by 4 (3.6%) teacher candidates under this category. These metaphors are “cat” (2), “love” (1), “instrument” (1). When the metaphors were analyzed, it was found that the teacher candidates who came up with these teachers perceived mathematics as a figure that requires continuity. These teacher candidates pointed out that it is necessary to be continuously involved in mathematics, otherwise its knowledge could be quickly forgotten and that it is a field of science which requires continuous interest. Quotes from teacher candidates' who came up with the category mathematics as a figure that requires continuity are as follows:

"Mathematics is like a cat. However much you take care of it, it is ungrateful. Just a bit of decrease in your interest, it will not even recognize you." (teacher candidate 60, female).

"Mathematics is like a musical instrument because mathematics is ungrateful, like a musical instrument. If one does not pick up the instrument for a week, one loses two weeks of progress. So is mathematics, when we take a break from it, our ability to understand diminishes and we become unfamiliar to it." (teacher candidate 89, male).

Category 12: Mathematics as a figure that is yet to be solved

In total, there are 2 metaphors represented by 3 (2.7%) teacher candidates under this category. These metaphors are “crossword” (2), “aids” (1). When the metaphors were analyzed, it was found that the teacher candidates who developed these metaphors perceived mathematics as a figure that is yet to be solved. These teacher candidates stated that mathematics has many problems to which solutions have not yet been found and that they were still in search for answers. Quotes from teacher candidates' who came up with the category mathematics as a figure that is yet to be solved are as follows:

"Mathematics is like a crossword. There are many interesting questions and problems that are yet to be solved. There are problems that have not yet been solved for years in the subject of prime numbers alone." (teacher candidate 63, female).

"Mathematics is like Aids. They both have many details that have not yet been discovered and may never be." (teacher candidate 50, female).

Category 13: Mathematics as a mind-developing figure

In total, there are 3 metaphors represented by 3 (2.7%) teacher candidates under this category. These metaphors are “vitamins” (1), “drug” (1), “brain teaser”. When the metaphors were analyzed, it was found that teacher candidates who developed these metaphors perceived mathematics as a mind-developing figure. These teacher candidates pointed out that engaging in mathematics would broaden one's horizon, increase one's level of intelligence and that it would refresh one's outlook on life. Quotes from teacher candidates' who came up with the category mathematics as a mind-developing figure are as follows:

"Mathematics is like a brain teaser. When a person is in the middle of solving a brain teaser s/he would be exercising logic on one hand and making calculations on the other; s/he would be doing the same when dealing with mathematics. In this way, we are able to develop our minds and at the same time learn to view life from another angle." (teacher candidate 88, female).

"Mathematics is like vitamins. Taking vitamins benefits a person's mind, and so does mathematics. (teacher candidate 93, male).

Category 14: Mathematics as a figure with a single correct answer

In total, there are 1 metaphors represented by 2 (1.8%) teacher candidates under this category. This metaphor is “maze”. When the metaphors were analyzed, it was found that teacher candidates who developed these metaphors perceived mathematics as a figure with a single correct answer. These teacher candidates stated that there were many paths to reach a solution however there is single correct answer. Quotes from teacher candidates' who came up with the category mathematics as a figure with a single correct answer are as follows:

"Mathematics is like a maze. There are many paths to take in a maze. By treading some of them we may not be able to reach the exit and by other we may. However, there is only one exit. Such is mathematics; there are many ways to reach a solution but there is only one solution." (teacher candidate 66, female).

"Mathematics is like a maze. There are many labyrinthine routes in a maze; however, only one exit, which is the case with mathematics, as there is a single correct solution." (teacher candidate 103, female).

DISCUSSION and CONCLUSION

In this study, the perceptions of mathematics teacher candidates were examined through metaphor analysis. In this study, the metaphors developed by mathematics teacher candidates in this study were grouped under 14 categories. According to these categories, about 77% of mathematics teacher candidates perceived mathematics as “Limitless”, “Interconnected”, “Basically needed”, “Fun”, “Cumulative”, “Indispensable” figure and as a

figure which laid the “foundation for other sciences”. The remaining 23% perceived mathematics as “Hard-to-understand”, “Guiding”, “Universal language”, “Requiring continuity”, “Yet to be solved”, “Mind developing” and “Having single correct answer”. According to the results of this study, only the group of mathematics teacher candidates who represented “mathematics as a figure difficult to understand” category had negative perceptions and the mathematics teacher candidates who represent all the remaining categories had positive perceptions with regard to mathematics.

Some of the mathematics teacher candidates in this study defined mathematics as limitless and interconnected figure. Similarly in a study by Kılıç (2011) it was reported that prospective elementary mathematics teachers stated that mathematics subjects were infinite and interconnected. Besides, in a study by Schinck et al. (2008) it was stated that 9th and 10th grade students emphasized that mathematics subjects were interconnected.

Besides, some of the mathematics teacher candidates who took part in this study found mathematics as a fun and enjoyable figure. In similar studies, students, teacher candidates and adults defined mathematics as fun and enjoyable figure (Lim, 1999; Lim and Ernest, 1998; Schinck et al, 2008; Kılıç, 2011). However, some of the teacher candidates in this study perceived mathematics as challenging and incomprehensible. Previous studies also revealed similar findings (Lim, 1999; Lim and Ernest, 1998; Schinck et al., 2008; Uçar et. al, 2010; Kılıç, 2011).

Another finding revealed in this study is that mathematics teacher candidates regarded mathematics as a universal language and as the foundation of other sciences. Similarly, in a study by Noyes (2006) on mathematics teacher candidates, it was found that mathematics was perceived as a universal language and the foundation for other sciences.

Yet another finding of the study is that mathematics teacher candidates hold the view that mathematics is a branch of science which requires effort and permanence. This finding is line with the findings of other related studies (Lim, 1999; Lim and Ernest, 1998; Schinck et al, 2008).

RECOMMENDATIONS

In this study, perceptions of mathematics teacher candidates with regard to mathematics concept were examined and significant findings were obtained. The following suggestions can be made under the light of the results of the study:

1. In pre-service education given to mathematics teacher candidates, education environments which will enable prospective teachers to develop positive perceptions with regard to the concept of mathematics should be created.
2. Courses about history and nature of mathematics can be given to mathematics teacher candidates so that they have positive perceptions about mathematics.
3. In order to determine perceptions of students and mathematics teachers with regard to the concept of mathematics similar qualitative or quantitative studies can be conducted.

REFERENCES

- Alger, C. (2009). Secondary Teachers' Conceptual Metaphors of Teaching and Learning: Changes over the Career Span. *Teaching and Teacher Education*, 25(5), 743-751
- Carlson, T. (2001). Using metaphors to enhance reflectiveness among pre-service teachers. *Journal of Physical Education, Recreation and Dance, (JOPERD)*, 72 (1), 49-53.
- Ernest, P. (2010). Mathematics and Metaphor. *An International Journal of Complexity and Education*, 7 (1), 98-104.
- Guerrero, M. C. M. & Villamil, O. S. (2002). Metaphorical conceptualizations of ESL teaching and learning. *Language Teaching Research*, 6, 95-120.
- Güler, G., Öçal, M. F. & Akgün, L. (2011). Pre-service mathematics teachers' metaphors about mathematics teacher concept. *Procedia Social and Behavioral Sciences*, 15,327–330.
- Kılıç, Ç. (2011). Belgian and Turkish pre-service primary school mathematics teachers' metaphorical thinking about mathematics. *CERME 7*, Rzeszow, Poland.
- Kovecses, Z. (2010). *Metaphor: A practical introduction*. New York: Oxford University Pres.
- Lakoff, G. & Nunez, R. E. (2000). *Where mathematics comes from: How the embodied mind brings mathematics into being*. New York: Basic books.
- Lakoff, G. & Johnson, M. (2003). *Metaphors we live by*. Chicago: University of Chicago Press.

- Leavy, A. M., Mc Sorley, F. A., & Bote, L. A. (2007). An examination of what metaphor construction reveals about the evolution of preservice teachers' beliefs about teaching and learning. *Teaching and Teacher Education*, 23, 1217-1233.
- Lim, C. S. & Ernest, P. (1998). A survey of public images of mathematics. *BSRLM Proceedings*, 18(1), 7-14.
- Lim, C. S. (1999). Using metaphor analysis to explore adults' images of mathematics. *Philosophy of Mathematics Education Journal* 12.
- Noyes, A. (2006). Using metaphor in mathematics teacher preparation. *Teaching and Teacher Education*, 22, 898-909.
- Picker, S. H. & Berry, J. S. (2000). Investigating pupil's images of mathematicians. *Educational Studies in Mathematics*, 43(1), 65-94.
- Raymond, A. M. (1997). Inconsistency between beginning elementary school teacher's mathematics beliefs and teaching practice. *Journal for Research in Mathematics Education*, 28(5), 550-576.
- Reeder, S. Utley, J. & Cassel, D. (2009). Using metaphors as a tool for examining preservice elementary teachers' beliefs about mathematics teaching and learning. *School Science and Mathematics*, 109(5), 290-297.
- Rock, D. & Shaw, J. M. (2000). Exploring children's thinking about mathematicians and their work. *Teaching Children Mathematics*, 6(9), 550-555.
- Romanyshyn, R. D. (2001). *Mirror and metaphor: Images and stories of psychological life*. Pittsburgh: Trivium.
- Saban, A. (2004). Entry level prospective classroom teachers' metaphors about the concept of "teacher". *Türk Eğitim Bilimleri Dergisi*, 2(2): 131-155.
- Saban, A., Koçbeker, B. N. & Saban, A. (2006). An investigation of the concept of teacher among prospective teachers through metaphor analysis. *Kuram ve Uygulamada Eğitim Bilimleri*, 6 (2), 461-522.
- Saban, A. (2009). Öğretmen Adaylarının Öğrenci Kavramına İlişkin Sahip Oldukları Zihinsel İmgeler. *Türk Eğitim Bilimleri Dergisi*, 7(2), 281-326.
- Schinck, A. G., Neale, H. W., Pugalee, D.K., & Cifarelli, V.V. (2008). Structures, Journeys, and Tools: Using metaphors to unpack student beliefs about mathematics. *School Science and Mathematics*, 594-599.
- Sterenber, G. (2008). Investigating teachers' images of mathematics. *Journal of Mathematics Teacher Education*, 11, 89-105.
- Uçar, Z., Pişkin, M., Akkaş, E. N. & Taşçı, D. (2010). Elementary students' beliefs about mathematics, mathematics' teachers and mathematicians. *Education and Science*, 35(155), 132-144.
- Yob, I. M. (2003). Thinking constructively with metaphors. *Studies in Philosophy and Education*, 22, 127-138.

FATİH PROJESİ İL KOORDİNATÖRLERİ VE EĞİTMENLERİNİN, FATİH PROJESİ KAPSAMINDA VERİLEN EĞİTMEN EĞİTİMLERİNE İLİŞKİN GÖRÜŞLERİ

VIEWS OF CITY COORDINATORS AND INSTRUCTORS OF FATİH PROJECT ON INSTRUCTOR TRAINING GIVEN IN THE SCOPE OF FATİH PROJECT

Halit ARSLAN
arslanhalit@hotmail.com

İsmail ŞAHİN
isahin@konya.edu.tr

ÖZET: Bu araştırmanın amacı; FATİH Projesi il koordinatörlerinin, il eğitici formatörlerinin eğitimcilerinin FATİH Projesi kapsamında verilen eğitimci eğitimlerine ilişkin görüşlerini tespit etmektir. Nitel olarak desenlenen bu araştırma 2013 – 2014 eğitim öğretim yılında görev yapan 20 katılımcıyla gerçekleştirilmiştir. Görüşme tekniği ile elde edilen veriler, içerik analizi yöntemi ile analiz edilmiştir. Araştırmada elde edilen bulgulara göre; katılımcıların yarısından fazlasının FATİH eğitimlerinin eksik yanının olmadığını belirterek sayı, eğitim saati ve içerik bakımından yeterli buldukları sonucuna ulaşılmıştır. Ayrıca katılımcılar FATİH eğitimlerinin; sosyal etkileşim, yeni bilgi öğrenme, projeyi tanıma, gezi gibi mesleki ve kişisel açıdan kendilerine katkı sağlayacak yönleri olduğunu belirtmişlerdir. FATİH eğitimleri esnasında karşılaşılan zorluklar ise kursiyerlerdeki isteksizlik, yorgunluk, donanımsal problemler ve kurs saatlerinden kaynaklanan problemler şeklinde belirtilmiştir. Katılımcıların görev aldıkları FATİH eğitimlerinin sonunda, kendi kursiyerlerinin aldıkları eğitime yönelik dönütleri ise bu eğitimlerin gerekli ve faydalı olduğu yönünde olmuştur. Katılımcıların büyük çoğunluğu FATİH Projesi kapsamında verilen eğitimlerin zorunlu olması gerektiğini belirtmişlerdir. Çalışmada elde edilen veriler analiz edilmiş, bulgular doğrultusunda tartışılmış ve öneriler getirilmiştir.

Anahtar Kelimeler: FATİH Projesi, Hizmetiçi Eğitim, FATİH Eğitimcileri.

SUMMARY: The purpose of this study is to determine the views of city coordinators and trainers of the FATİH Project on instructor training given in the scope of FATİH project. The study was designed in qualitative method and was performed with 20 participants who were at active duty in the 2013 – 2014 academic year. The data obtained with interview technique were analyzed with content analysis technique. According to the findings of the study, more than half of the participants stated that the FATİH project trainings had no missing points and that they found these trainings successful in terms of training frequency, hours and contents. The participants also stated that the FATİH Project trainings had useful vocational and personal contributions to them in which social interaction, learning new information, recognizing the project better and traveling were involved. The challenges during the FATİH trainings were stated to be the unwillingness in the participants for the trainings, weariness, software problems and course hours. At the end of the FATİH trainings in which the participants took part, the feedbacks they received stated that the trainings were useful and necessary. Most of the participants stated that the trainings provided in the scope of the FATİH Project should be compulsory. The data obtained during the study were analyzed and the findings were discussed and suggestions were made.

Key Words: FATİH Project, In-Service Training, FATİH Instructors.

GİRİŞ

Eğitim en genel haliyle; insanları belli amaçlara göre yetiştirme süreci olarak ifade edilebilir (Fidan, 2012). Eğitim ihtiyacını Turgut (2012); çalışan personelin görevini en iyi şekilde yerine getirebilmesi için gerekli olan bilgi, beceri ve davranışları geliştirmede istenilen önemli bir nokta şeklinde ifade etmiştir. Teknolojinin ise diğer alanlarda olduğu gibi eğitim alanında da geçmişten günümüze birçok yeniliği beraberinde getirdiği görülmektedir. Çünkü teknolojinin eğitimde daha sık kullanılmasıyla birlikte öğretmen ve öğrencilerin işlerinin daha çok kolaylaştığı görülmektedir. Heafner'e (2004) göre eğitimde teknolojinin kullanımı; öğrencilerin öğrenme sürecine yoğunlaşmalarını teşvik ederek, öğrencilerin kendilerine olan güvenlerini artırmalarını sağlamakta, dolayısıyla onların bilişsel becerilerinin de gelişmesini etkilemektedir. İnel, Evrekli ve Balım'ın (2011), teknoloji ve eğitimin bütünleşmesine ilişkin ortak kanısı, öğrenme ve öğretme süreçlerinin daha verimli hale gelerek, daha vasıflı kişiler yetişmesine olanak sağlayacağı inancıdır.

Ülkemizde teknolojinin eğitimde kullanılmasıyla ilgili çalışmalar sürekli artış göstermektedir. Bu projelerin en sonuncusu Milli Eğitim Bakanlığı ve Ulaştırma Bakanlığının ortaklaşa yürüttüğü FATİH (Fırsatları Artırma Teknolojiyi İyileştirme Hareketi) Projesi'dir. Eğitimde FATİH Projesi, eğitim ve öğretimde fırsat eşitliğini sağlamak ve okullardaki teknolojiyi iyileştirmek amacıyla Bilişim Teknolojileri araçlarının öğrenme ve öğretme sürecinde daha fazla duyu organına hitap edecek şekilde, derslerde etkin kullanımı için; okulöncesi, ilköğretim ile ortaöğretim düzeyindeki okullara gereken teknolojik altyapıyı sağlaması için tasarlanmıştır (FATİH Projesi, 2014).

FATİH Projesi beş ana bileşenden oluşmaktadır (FATİH Projesi, 2014). Bunlar:

- ✓ Donanım ve Yazılım Altyapısının Sağlanması
- ✓ Eğitsel e-İçeriğin Sağlanması ve Yönetilmesi
- ✓ Öğretim Programlarında Etkin BT Kullanımı
- ✓ Öğretmenlerin Hizmetiçi Eğitimi
- ✓ Bilinçli, Güvenli, Yönetilebilir ve Ölçülebilir BT Kullanımının sağlanmasıdır.

Bu bileşenlerin dördüncü basamağı olan "Öğretmenlerin Hizmetiçi Eğitimi" maddesi de en az diğerleri kadar önem arz etmektedir. Bir mesleğin koşullarını, daha önceki alınan eğitimlerle yerine getirmekte zorlanan personelin hizmetiçi eğitimle kendini geliştirme zorunluluğu doğmaktadır (Taymaz, 1997). Seferoğlu'na (2004) göre hizmetiçi eğitim; öğretmenlerin niteliklerini artırma, potansiyellerini tam olarak ortaya çıkarma ve kullanma becerisi kazandırmaya yönelik önemli bir süreçtir. Çünkü okul personelinin performansını, öğretmenlerin mesleki becerisini, kişisel veya genel eğitimini geliştirmek ve kariyer gelişimi için deneyimlerini arttırmak gibi hedefler içermektedir. Hizmetiçi eğitimlerin sonrasında kazanılması amaçlanan en temel öğelerden birisi olan mesleki gelişim kavramını ise Guskey (2002) öğretmenlerin öğrencilerini ilerletmek için, eğitimcilerin mesleki bilgi, beceri ve tutumlarını geliştirmek üzere düzenlenen süreç ve etkinlikler şeklinde tanımlanmıştır.

FATİH Projesi kapsamında okullara kurulan teknolojinin etkili kullanımıyla ilgili öğretmenlere yönelik çeşitli eğitimler planlanmıştır. 2014 Merkezi Hizmetiçi Eğitim planına göre FATİH Projesiyle ilgili aşağıdaki kurslar açılmaktadır (ÖYGM, 2014):

- ✓ Eğitimde FATİH Projesi (Teknoloji Kullanım Kursu)
- ✓ Eğitimde FATİH Projesi (Pardus Kullanım Kursu)
- ✓ FATİH Projesi BT'nin Bilinçli, Güvenli Kullanımı Semineri
- ✓ FATİH Projesi Ağ Altyapısı Semineri
- ✓ FATİH Projesi Branş Dersleri Uygulama Örnekleri Semineri
- ✓ FATİH Projesi – Teknoloji ve Liderlik Forumu Kursu

Yukarıda belirtilen eğitimlerden, *FATİH Projesi Teknoloji Kullanım Kursu* eğitimi alan kişiler FATİH eğitmeni olmaya hak kazanmaktadırlar (FATİH - Eğitmen Listesi, 2014). Ayrıca 81 ilde FATİH projesinin yürütülmesiyle ilgili görevli il koordinatörleri ve Eğitici BT Formatör Öğretmenleri bulunmaktadır. İl koordinatörleri ve eğitici BT formatör öğretmenlerinin görevleri arasında buldukları il ya da ilçede FATİH projesinin işleyişini takip etmek ve o yerleşim yerindeki tüm öğretmenlerin FATİH hizmetiçi eğitimlerini almalarını sağlamak da bulunmaktadır. Koordinatör ve eğitimcilerin sayı olarak yeterli olmadığı durumlarda ise FATİH eğitmenleri bir yandan okullarındaki görevlerine devam ederken diğer yandan hizmetiçi eğitimlerde görev alma imkânı bulmaktadırlar (Telli, 2012).

Araştırmanın Amacı

Bu araştırmanın amacı FATİH Projesi il koordinatörlerinin, il eğitici formatörlerinin ve FATİH Projesi eğitmenlerinin FATİH Projesi kapsamında verilen hizmetiçi eğitmen eğitimlerine ilişkin görüşlerini tespit etmektir. Bu amaç doğrultusunda aşağıdaki araştırma sorularına cevap aranmıştır:

- Katılımcıların aldıkları FATİH eğitimlerini yeterli bulma durumları nelerdir?
- Katılımcıların verdikleri FATİH eğitimlerini yeterli bulma durumları nelerdir?
- Katılımcıların FATİH eğitimlerinde gördükleri eksiklikler nelerdir?
- Katılımcıların FATİH eğitimlerinin katkılarına yönelik görüşleri nelerdir?
- Katılımcıların verdikleri FATİH eğitimlerinde yaşadıkları problemler nelerdir?
- Katılımcıların FATİH eğitimlerinin zorunlu olmasına yönelik görüşleri nelerdir?
- Katılımcıların FATİH projesinin katkılarına yönelik görüşleri nelerdir?
- Katılımcıların kursiyerlerinin FATİH eğitimlerine yönelik görüşleri nelerdir?

YÖNTEM

Araştırma Modeli

FATİH Projesi il koordinatörlerinin, il eğitici formatörlerinin ve FATİH Projesi öğretmenlerinin FATİH Projesi kapsamında verilen hizmetiçi eğitim eğitimlerine ilişkin görüşlerini tespit etmenin hedeflendiği bu araştırma nitel bir çalışma olup, durum çalışması deseni şeklindedir. Araştırılan olguyu kendi yaşam çerçevesi içinde inceleyen, olgu ve içinde bulunduğu ortam arasındaki sınırların kesin hatlarla belirgin olmadığı ve birden fazla kanıt veya veri kaynağının mevcut olduğu durumlarda kullanılan bir araştırma desendir (Yıldırım ve Şimşek, 2006; Yin, 1984).

Katılımcılar

Araştırma; 2013 – 2014 eğitim öğretim yılında görev yapan 20 FATİH Projesi öğretmeninin katılımıyla gerçekleştirilmiştir.

Katılımcıların demografik özelliklerine ilişkin frekans ve yüzde dağılımları aşağıda sırasıyla verilmiştir. Görev türüne göre katılımcı sayısı Tablo 1’de belirtilmiştir.

Tablo 1. Görev Türüne Göre Katılımcı Sayısı

Değişken	Gruplar	f	%
Mesleki Görev	BT İl Koordinatörü	3	15
	Eğitici BT Formatör Öğretmeni	10	50
	FATİH Projesi Eğitmeni	7	35

Tablo 1 incelendiğinde; katılımcıların yarısının (n=10) eğitici BT formatör öğretmenlerden oluştuğu görülmektedir. Tablo 2’de katılımcıların cinsiyetleri belirtilmiştir.

Tablo 2. Cinsiyete Göre Katılımcı Sayısı

Değişken	Gruplar	f	%
Cinsiyet	Erkek	17	85
	Kadın	3	15

Tablo 2 incelendiğinde; katılımcıların büyük çoğunluğunu (n=17) erkek öğretmenler oluşturmaktadır. Tablo 3’te katılımcıların mesleki kıdem yılları belirtilmiştir.

Tablo 3. Kıdeme Göre Katılımcı Sayısı

Değişken	Gruplar	f	%
Kıdem	1 – 5 Yıl	2	10
	6 – 10 Yıl	8	40
	11 – 15 Yıl	6	30
	16 – 20 Yıl	2	10
	21+ Yıl	2	10

Tablo 3 incelenecek olursa; katılımcıların yaklaşık %70’i 6 – 15 yaş arası kıdeme sahip oldukları belirtilmiştir. Tablo 4’te katılımcıların FATİH Projesi kapsamında verilen hizmetiçi eğitimlerine katılım durum durumları belirtilmiştir.

Tablo 4. Aldıkları Eğitimlere Göre Katılımcı Sayısı

Değişken	Gruplar	f	%
Eğitim Alma Durumları	FATİH Projesi (Tekn. Kullanımı) Kursu	20	100
	Fatih Projesi Ağ Altyapısı Semineri	14	70
	BT'nin Bilinçli, Güvenli Kullanımı Semineri	9	45
	FATİH Projesi (Pardus Kullanımı) Kursu	8	40

Tablo 4 incelenecek olursa; katılımcıların tamamı *FATİH Projesi (Teknoloji Kullanımı) Kursu* eğitimini başarıyla tamamlayıp FATİH eğitmeni olmaya hak kazanmışlardır. Ayrıca katılımcıların yarıdan fazlasının

(n=14) *Fatih Projesi Ağ Altyapısı Seminerini* aldığı görülmektedir. Tablo 5’te katılımcıların FATİH Projesi kapsamında görev aldıkları hizmetiçi eğitimler belirtilmiştir.

Tablo 5. Verdikleri Eğitimlere Göre Katılımcı Sayısı

Değişken	Gruplar	f	%
Eğitim Verme Durumları	FATİH Projesi (Tekn. Kullanımı) Kursu	20	100
	FATİH Projesi Hazırlayıcı Eğitim	14	70
	FATİH Projesi Tanıtım Semineri	11	55
	BT'nin Bilinçli, Güvenli Kullanımı Semineri	9	45
	FATİH Projesi (Pardus Kullanımı) Kursu	2	10

Tablo 5 incelenecek olursa; katılımcıların tamamı *FATİH Projesi (Teknoloji Kullanımı) Kursunun* eğitimini verdikleri görülmektedir. Ayrıca katılımcıların çoğu, *FATİH Projesi (Pardus Kullanımı) Kursu* (n=2) haricindeki kurslarda eğitmen olarak görev almışlardır.

Veri Toplama Araçları

FATİH Projesi il koordinatörlerinin, il eğitici formatörlerinin ve FATİH Projesi eğitmenlerinin FATİH Projesi kapsamında verilen eğitmen eğitimlerine ilişkin görüşlerini tespit etmenin hedeflendiği bu çalışmada araştırmacı tarafından geliştirilen ve on sorudan oluşan bir adet yarı - yapılandırılmış görüşme formu kullanılmıştır. Yarı-yapılandırılmış görüşme formu nitel alanda veri toplama amacıyla kullanılan tekniklerden birisidir. Bu yöntemde katılımcıların sorulara yanıtlar vermesi istenmektedir ve bu yanıtlar sesli olarak kaydedilmekte, sonra yazılı formata dönüştürülmektedir (Creswell, 2005; Yıldırım & Şimşek, 2006). Veriler araştırmacılar tarafından toparlanmış, verilerin kâğıda döküm işlemi gerçekleştirilmiştir.

Verilerin Analizi

Verilerin incelenmesinde nitel çalışmalarda sıklıkla kullanılan “içerik analizi” tekniği kullanılmıştır. İçerik analizi kuramsal anlamda belirgin olmayan temalar ve eğer varsa alt temaların oluşturularak analiz edilmesi şeklinde gerçekleştirilmektedir (Yıldırım & Şimşek, 2006). İçerik analizi için verilerden alınan verilerin indekslere işlenmesi, indekslerden kodların oluşturulması, kodlardan temaların çıkarılması, temaların düzenlenerek tanımlanması ve bu temalar doğrultusunda bulguların ortaya konarak yorumlanması şeklinde içerik analizi için gerekli olan işlemler sırası ile takip edilmiştir (Yıldırım & Şimşek, 2006).

Verilen kodlanması, kodlardan temaların oluşturulması ve temaların tanımlanmasında verilerin güvenilirliği için veriler iki araştırmacı tarafından ayrı ayrı kodlanmıştır. Araştırmacıların yanıtları karşılaştırılarak Miles ve Huberman (1994) tarafından ortaya konan Görüş Birliği / (Görüş Ayrılığı + Görüş Birliği)*100 formülü ile çalışmanın güvenilirliği yaklaşık %88 olarak hesaplanmıştır. Güvenilir ve analize uygun olduğu ortaya konulan veriler kodlara, ardından da bu kodlardan temalara dönüştürülerek, başlıklar halinde bulgular yorumlanmıştır.

BULGULAR

Katılımcıların FATİH Projesi kapsamında aldıkları hizmetiçi eğitimleri sayı, eğitim saati ve içerik bakımından yeterli bulup bulmama durumları Tablo 6’da belirtilmiştir.

Tablo 6. Katılımcıların Aldıkları Eğitimi Yeterli Bulma Durumları

No	Gruplar	f	%
1	Yeterli Olduğumu Düşünüyorum	14	70
2	Yeterli Olduğumu Düşünmüyorum	6	30
	TOPLAM	20	100

Tablo 6 incelendiğinde katılımcıların %70’i katıldıkları hizmetiçi eğitimleri sayı, eğitim saati ve içerik bakımından yeterli bulduklarını belirtmişlerdir. Katılımcıların FATİH Projesi kapsamında eğitimini verdikleri hizmetiçi eğitimleri sayı, eğitim saati ve içerik bakımından yeterli bulup bulmama durumları Tablo 7’de belirtilmiştir.

Tablo 7. Katılımcıların Verdikleri Eğitimi Yeterli Bulma Durumları

No	Gruplar	f	%
1	Yeterli Olduğumu Düşünüyorum	17	85
2	Yeterli Olduğumu Düşünmüyorum	3	15
	TOPLAM	20	100

Tablo 7 incelendiğinde katılımcıların tamamına yakını (n=17) görev aldıkları hizmetiçi eğitimleri sayı, eğitim saati ve içerik bakımından yeterli bulduklarını belirtmişlerdir. Katılımcıların FATİH eğitimlerinde gördükleri eksik yanlar Tablo 8’de belirtilmiştir.

Tablo 8. Katılımcıların FATİH Eğitimlerinde Gördükleri Eksiklikler

No	Gruplar	f	%
1	Eksiklik Yok	12	57,12
2	Uygulama Yetersiz	3	14,29
3	Süre Yetersiz	3	14,29
4	İçerik Yetersiz	2	9,54
5	Konaklama Hizmetleri Yetersiz	1	4,76
	TOPLAM	21	100

Tablo 8 incelendiğinde katılımcıların yarısından fazlası (n=12) FATİH projesi eğitimlerinde eksiklik olmadığı görüşünü belirtmişlerdir. Katılımcılara FATİH eğitimlerinde mesleki ve kişisel açıdan ne gibi katkı sağladıkları sorulmuş ve cevaplar Tablo 9’da belirtilmiştir.

Tablo 9. Katılımcıların FATİH Eğitimlerinin Katılarına Yönelik Görüşleri

No	Gruplar	f	%
1	Sosyal Etkileşim	10	35,71
2	Yeni Bilgi Öğrenme	7	24,99
3	Projeyi Tanıma	6	21,44
4	Kurs Açma İmkânı	3	10,72
5	Gezi	2	7,14
	TOPLAM	28	100

Tablo 9 incelendiğinde katılımcıların yarısı (n=10) FATİH eğitimlerinin en büyük katkısının sosyal etkileşim olduğunu belirtmişlerdir. Ayrıca yeni bilgi öğrenme, projeyi daha yakından tanıma gibi katkıların olduğu görüşü de ön plana çıkmıştır. Katılımcıların FATİH eğitimlerini verirken yaşadıkları problemler Tablo 10’da belirtilmiştir.

Tablo 10. Katılımcıların FATİH Eğitimlerinde Problem Yaşama Durumları

No	Gruplar	f	%
1	Katılımcılarda İsteksizlik	8	22,88
2	Katılımcılarda Yorgunluk	6	17,16
3	Donanımsal Problemler	6	17,16
4	Kurs Saati	5	14,30
5	İhtiyaç Duymama	4	11,34
6	Karma Branş Olması	2	5,72
7	Teknoloji Acemiliği	2	5,72
8	Elektrik ve İnternet Kesintisi	1	2,86
9	Problem Yaşamadım	1	2,86
	TOPLAM	35	100

Tablo 10 incelendiğinde katılımcıların eğitimlerde yaşadıkları sıkıntıların başında kursiyerlerin isteksiz ve yorgun olmaları gelmektedir. Ayrıca donanımsal problemler ve kurs saatinin isteklere göre olmaması temaları da eğitimlerde karşılaşılan problemlere örnek olarak belirtilmiştir. Katılımcıların FATİH eğitimlerinin zorunlu olarak verilmesine yönelik görüşleri Tablo 11’de belirtilmiştir.

Tablo 11. Katılımcıların FATİH Eğitimlerinin Zorunlu Olmasına Yönelik Görüşleri

No	Gruplar	f	%
1	Zorunlu Olmalı	14	70
2	Zorunlu Olmamalı	6	30
TOPLAM		20	100

Tablo 11 incelendiğinde katılımcıların %70'i FATİH eğitimlerinin zorunlu olmasını istemektedirler. 6 katılımcı ise eğitimlerin zorunlu olmaması gerektiğini belirtmişlerdir. Katılımcıların; FATİH Projesinin eğitime ve eğitimcilere ne gibi katkılar sağlayacağına yönelik görüşleri ve beklentileri Tablo 12'de belirtilmiştir.

Tablo 12. Katılımcıların FATİH Projesinin Katkılarına Yönelik Görüşleri

No	Gruplar	f	%
1	BT Kullanım Becerisi	10	32,30
2	Kolay Öğrenme	7	22,51
3	Fırsat Eşitliği	5	16,13
4	Tablet Dağıtım	4	12,92
5	Bireysel Öğrenme	3	9,68
6	Katkısı Yok	2	6,46
TOPLAM		31	100

Tablo 12 incelendiğinde katılımcılara göre FATİH projesinin en büyük katkılarının bilişim teknolojileri kullanım becerisini geliştireceği, kolay öğrenmenin gerçekleşeceği ve eğitimde fırsat eşitliğinin sağlanacağı maddeleri olduğu görülmektedir. Katılımcılara eğitim verdikleri FATİH kurslarının sonunda kursiyerlerinden ne gibi dönütler aldıkları sorulmuş ve alınan cevaplar Tablo 13'te belirtilmiştir.

Tablo 13. Katılımcıların Kursiyerlerinin FATİH Eğitimlerine Yönelik Görüşleri

No	Gruplar	f	%
1	Gerekli ve Faydalı	17	58,60
2	Süresi Fazla	4	13,80
3	Kendini Yetersiz Bulma	3	10,35
4	Eğitimler Yetersiz	3	10,35
5	Gereksiz	2	6,90
TOPLAM		29	100

Tablo 13 incelendiğinde katılımcıların kursiyerlerinin FATİH eğitimlerine yönelik görüşlerinin başında bu eğitimlerin gerekli ve faydalı olduğu gelmektedir. Ayrıca eğitimlerin süresini fazla bulan, eğitimleri yetersiz ve gereksiz bulan veya teknoloji kullanımı konusunda kendini yetersiz bulan az sayıda katılımcı olduğu görülmektedir.

TARTIŞMA ve SONUÇ

Katılımcılara FATİH Projesi kapsamında aldıkları hizmetiçi eğitimleri sayı, eğitim saati ve içerik bakımından yeterli bulup bulmama durumları sorulmuştur. Katılımcıların çoğu eğitimleri yeterli görürken 6 katılımcı (4, 6, 7, 9, 16 ve 19. Kursiyerler) eğitimlerin yeterli olmadığını belirtmiştir. Bunun nedeni katılımcıların aldıkları FATİH Projesi hizmetiçi eğitim sayısının azlığından kaynaklanabilir. 6 katılımcının tamamı ancak bir veya iki defa FATİH eğitimlerinde sertifika almaya hak kazanmışlardır. Her FATİH eğitimi farklı bir alanda konular içerdiği için katılımcıların eğitimleri yetersiz bulmaları bu sebepten kaynaklanabilir. Şahin, Çek ve Zeytin (2011) ise eğitim müfettişlerinin hizmetiçi eğitim kurslarının yeterliliğine ilişkin yapmış oldukları çalışmada hizmetiçi eğitime katılan müfettişlerin %87,4'ünün eğitimleri yeterli bulmadıkları sonucuna ulaşmışlardır.

Katılımcılara FATİH Projesi kapsamında verdikleri hizmetiçi eğitimleri sayı, eğitim saati ve içerik bakımından yeterli bulup bulmama durumları sorulmuştur. Katılımcıların büyük bir kısmı (n=17) eğitimleri yeterli görürken 3 katılımcı (7, 16 ve 19. Kursiyerler) eğitimlerin yeterli olmadığını belirtmiştir. Bu 3 katılımcının ortak yanı, sertifika aldığı FATİH eğitimlerini yeterli bulmayan 6 eğitmenin arasında bulunmasıdır. Katılımcıların eğitim verdikleri kursları yeterli bulmamaları, sertifika aldıkları merkezi eğitimlerden yeterli verimi alamamalarından kaynaklanabilir.

Katılımcılara FATİH Projesi kapsamında aldıkları merkezi hizmetiçi eğitimlerde gördükleri eksiklikler sorulmuştur. Katılımcıların yarısından fazlası (n=12) eğitimleri yeterli görerek eksiklik olmadığını belirtmiştir. Üçer katılımcı kurs süresince yapılan uygulamaları ve eğitimin süresini yetersiz bulmuştur. FATİH eğitimlerini yeterli bulmayan iki katılımcı (7 ve 16. kursiyer) ise kursların içerik bakımından yetersiz olduğu görüşünü belirtmişlerdir. Eğitimleri yetersiz bulan kişilerin genelde aynı kişiler olması ve bunun nedeninin de az sayıda eğitime katılmalarından kaynaklandığı düşünülecek olursa genel anlamda eğitimlerde ciddi eksiklik yaşanmadığı söylenebilir. Bu sonuç Şahin, Çek ve Zeytin'in (2011) bulgularıyla benzerlik göstermektedir.

Şahin, Çek ve Zeytin'in (2011) araştırmasındaki ilköğretim müfettişlerinin hizmetiçi eğitimlerde gördükleri eksikliklerden; mesleki içerik, sayı, süre maddeleri benzerlik göstermektedir.

FATİH eğitimlerinin katılımcıların mesleki ve kişisel gelişimlerine etkileri incelenecek olursa "sosyal etkileşim" teması ilk sırada yer almaktadır. Ayrıca katılımcılar; yeni bilgi öğrenme, FATİH projesini tanıma, gezi ve turlara katılma ve mahalli kurs açma gibi imkânlar katılımcıların söylemleri arasında yer almıştır. Bu sonuçlar, Arslan (2013) ve Yeşiltepe'nin (2012) çalışmalarıyla örtüşmektedir. Arslan (2013) çalışmasında hizmetiçi eğitimlerin BT öğretmenlerinin mesleki gelişimlerine yeni bilgi öğrenme ve mesleki deneyim gibi katkılar sağladığı, kişisel gelişimlerinde ise sosyal etkileşim ve yeni arkadaşlıklar edinme gibi katkılarının olduğu sonucuna ulaşmıştır. Yeşiltepe'nin (2012) çalışmasında ise, öğretmenler katıldıkları hizmetiçi eğitim faaliyetlerinin, bilgi birikimlerini öğrencilere aktarma konusunda olumlu katkılar sağladığını ve mesleki deneyim kazanma imkânı bulduklarını düşünmektedirler.

Katılımcılara FATİH Projesi kapsamında verdikleri hizmetiçi eğitimlerde problem yaşama durumları sorulmuştur. Katılımcıların kursiyerleriyle problem yaşama durumları genellikle isteksizlik, yorgunluk, donanımsal problemler, kurs saati ve eğitimlere ihtiyaç duymama maddeleri olarak belirlenmiştir. Bu bulguların Şahin, Çek ve Zeytin'in (2011) araştırmasındaki ilköğretim müfettişlerinin hizmetiçi eğitimlerin yeterliliğine ilişkin görüşleriyle örtüştüğü görülmektedir. Şahin, Çek ve Zeytin'in (2011) araştırmasında hizmetiçi eğitimlerin yetersiz olma nedenleri arasında gösterilen eğitim süresinin kısıllığı, ihtiyaç analizinin yapılmaması ve branşa göre eğitim yapılmaması maddeleri benzerlik göstermektedir.

Katılımcılara FATİH Projesi kapsamında verilen hizmetiçi eğitimlerin zorunlu olarak verilmesi durumu sorulmuştur. Elde edilen bulgulara göre katılımcıların %70'i zorunlu olması gerektiğini savunurken, %30'u zorunlu olmaması gerektiğini belirtmiştir. Bu bulguların Akar'ın (2007) çalışmasındaki bulgularla benzerlik gösterdiği görülmektedir. Akar (2007) Biyoloji öğretmenlerinin hizmetiçi eğitim ihtiyaçlarına yönelik yapmış olduğu çalışmasında katılımcıların yaklaşık %25'i hizmetiçi eğitimlere katılımın zorunlu olmasının katılımcı ve eğitimlerde verimi düşürdüğünü belirterek eğitimlerin zorunlu olmaması gerektiğini belirtmişlerdir.

Katılımcılara FATİH projesinin eğitime ve eğitimcilere ne gibi katkılar sağlayacağına yönelik görüşleri sorulmuştur. Elde edilen bulgulara göre katılımcıların yarısı (n=10) projenin BT kullanım becerisine katkı sağlayacağını belirtmişlerdir. Ayrıca öğrenmenin bireysel ve kolay gerçekleşmesi, eğitimde fırsat eşitliği ve donanımsal malzemelerin dağıtım maddeleri de katılımcıların görüşleri arasında yer almıştır. FATİH Projesinin amacı; eğitim ve öğretimde fırsat eşitliğini sağlamak ve okullardaki teknolojiyi iyileştirmek amacıyla BT araçlarının öğrenme ve öğretme sürecinde daha fazla duyu organına hitap edilecek şekilde, derslerde etkin kullanımını sağlayarak BT destekli öğretimin gerçekleşmesini sağlamaktır (FATİH Projesi, 2014). Dolayısıyla araştırmada elde edilen bulgulara göre katılımcıların görüşlerinin FATİH projesinin amaçlarıyla örtüştüğü söylenebilir.

Katılımcılara FATİH Projesi kapsamında verdikleri hizmetiçi eğitimlerdeki kursiyerlerinin FATİH eğitimlerine ilişkin görüşleri sorulmuştur. Elde edilen bulgulara göre; katılımcıların tamamına yakını (n=17) kursiyerlerinin FATİH eğitimlerini gerekli ve faydalı bulduklarını belirtmiştir. Bunun yanında katılımcıların kursiyerlerinden süreyi uzun bulan, eğitimleri yetersiz veya gereksiz bulan ve kendi teknoloji kullanım seviyesini yetersiz bulan kişiler olduğu görülmektedir.

ÖNERİLER

Araştırma kapsamında elde edilen bulgulara dayalı olarak aşağıdaki önerilerde bulunulabilir:

- ✓ İl koordinatörleri, il eğitici formatörleri ve FATİH Projesi eğitimcilerinin dışında bu eğitimlere katılmış tüm öğretmenleri kapsayan bir araştırma yapılabilir.
- ✓ Katılımcıların FATİH eğitimlerinde gördükleri eksiklikler dikkate alınarak; eğitimlerde uygulama, süre ve içerik konusunda beklentileri karşılayacak adımlar atılabilir.
- ✓ FATİH eğitimlerinde genelde şikâyet konusu olan kurs saatlerinin uygun saatlere kaydırılarak yorgunluk gibi problemlerin önüne geçilebilir.
- ✓ Öğretmenlerin FATİH eğitimlerinin içeriği hakkında kurs öncesinde bilgi edinmelerini sağlayarak isteksizlik gibi problemlerin önüne geçilebilir.
- ✓ Öğretmenlere FATİH eğitimlerinin neden zorunlu olması gerektiği konusunda açıklayıcı broşür, afiş gibi basılı ve yazılı materyaller temin etmeleri sağlanarak ihtiyaç duymama, eğitimleri gereksiz bulma gibi problemlerin önüne geçilebilir.
- ✓ Öğretmenler arasında teknoloji kullanım becerisi yüksek olmayan ya da bu alanda kendini yetersiz hisseden çok sayıda personel bulunduğu göz önünde bulundurularak temel bilgisayar kullanımı ile ilgili hizmetiçi eğitimlerin sayısı artırılabilir.

KAYNAKÇA

- Akar Ö., E. (2007). Biyoloji öğretmenlerinin hizmetiçi eğitim ihtiyaçları ve gözlemlenen bölgesel farklılıklar. *TED Eğitim ve Bilim*, 32, 143, 68-79.
- Arslan, H. (2013). Hizmetiçi Eğitim Kurslarının Bilişim Teknolojileri Öğretmenlerinin Mesleki ve Kişisel Gelişimine Etkisi. *Yayınlanmamış Yüksek Lisans Tezi*, Konya: Necmettin Erbakan Üniversitesi.
- Creswell, J. W. (2005). *Educational Research: Planning, Conducting, and Evaluating Quantitative and Qualitative Research* (2nd edition). N. J.: Pearson Merrill Prentice Hall.
- FATİH - Eğitimci Listesi, (2014).
http://fatihprojesi.meb.gov.tr/upload/Fatih_Projesi_Egitmen_Listesi_Nisan_2014.pdf
[Erişim Tarihi: 16.04.2014]
- FATİH Projesi Web Sitesi, (2014). <http://fatihprojesi.meb.gov.tr/tr/icerikincele.php?id=6>
[Erişim Tarihi: 16.04.2014]
- Fidan, N. (2012) *Okulda Öğrenme ve Öğretme*. Ankara: Pegem Akademi.
- Guskey, T. R. (2002). *Does it Make a Difference? Evaluating Professional Development*. *Educational Leadership*, 59, 6, 45-51.
- Heafner, T. (2004). Using Technology to Motivate Students to Learn Social Studies. *Contemporary Issues in Technology and Teacher Education*, 4(1), 42-53.
- İnel, D., Evrekli, E., Balım, A. G. (2011). Öğretmen Adaylarının Fen ve Teknoloji Dersinde Eğitim Teknolojilerinin Kullanılmasına İlişkin Görüşleri, *Afyon Kocatepe Üniversitesi Kuramsal Eğitim Bilim Dergisi*, 4(2), 128 - 150.
- Miles, M.B. & Huberman, A. M. (1994). *Qualitative Data Analysis* (2nd edition). Thousand Oaks, CA: SAGE.
- ÖYGM, (2014). Öğretmen Yetiştirme ve Geliştirme Genel Müdürlüğü Web Sitesi:
<http://oyegm.meb.gov.tr/www/2014-yili-egitim-plani/icerik/184>
[Erişim Tarihi: 16.04.2014]
- Seferoğlu, S. S. (2004). Öğretmenlerin hizmet içi eğitiminde yeni yaklaşımlar. *Akdeniz Üniversitesi Eğitim Fakültesi Dergisi*, 1.
- Şahin, S. & Çek, F. & Zeytin, N. (2011). Eğitim müfettişlerinin denetim sistemi ve hizmetiçi eğitim kurslarının yeterliliğine ilişkin görüşleri. *Kuram ve Uygulamada Eğitim Bilimleri*, 11(3), 1185-1201
- Taymaz, A.H. (1997). *Hizmetiçi Eğitim, Kavramlar, İlkeler, Yöntemler*. Ankara.
- Telli Yamamoto, G. (2012). *Eğitimde FATİH Projesi formatör sorunları çalıştay taslak raporu*. İstanbul: Okan Üniversitesi
- Turgut, S. (2012). İlköğretim Sınıf Öğretmenlerinin Hizmet İçi Eğitim İhtiyaçlarının Saptanması. *Yayınlanmamış Yüksek Lisans Tezi*, Burdur: Mehmet Akif Ersoy Üniversitesi, Eğitim Bilimleri Enstitüsü
- Yeşiltepe, G. M. (2012). İlköğretim Bilişim Teknolojileri Öğretmenlerinin Mesleğe Yönelik Sorunları, Bu Sorunların Nedenleri ve Çözüm Önerileri. *Yayınlanmamış Yüksek Lisans Tezi*, Antalya: Akdeniz Üniversitesi.
- Yıldırım, A. & Şimşek, H. (2006). *Sosyal Bilimlerde Nitel Araştırma Yöntemleri*. Ankara: Seçkin Yayınevi.
- Yin, R. K. (1984). *Case Study Research: Design and Methods*. Newbury Park, CA. : Sage.

SELF-CONCEPT AND SELF-EVALUATION IN THE TRANSITION FROM PRIMARY TO LOWER SECONDARY EDUCATION

Pranvera KRAJA
University of Shkodra, Faculty of Educational Science, Albania.
e-mail: v.kraja@yahoo.com

ABSTRACT: In this article I'll present theoretical concepts and empirical results of self-concept and self-esteem of the children in transition from primary school to lower secondary education (LSE). Through the evidences from research literature, this article, aims to provide answers to such questions: How and what aspects of self-concept and self-esteem of children develop and change during childhood and adolescence? Is there a correlation between levels of self-concept and self-assessment that the child has for him and his academic achievements? Why is it important to maintain high levels of self-concept and self-esteem of the child for the life in general, and for the school life in particular? Studies of the last two decades have shown that changes in self-concept and self-esteem of the child are strongly correlated with pupils' academic achievements. Keeping positive levels of self-concept and self-esteem, would facilitate the difficulties of the child's adjustment at the new school.

Keywords: school transition, self-concept, self-esteem, impact, lower secondary education.

INTRODUCTION

It has been paid great attention to children's transition from primary to lower secondary education (AMU), energy and desire by many researchers and university research teams, not only to understand the process, but also to determine the causes and factors affecting to the performance of children in the process. Because of the many changes that occur simultaneously in a child's life, the transition to high school is unique, unrepeatable. Changes that accompany this period include: changes in the learning environment, in the nature and structure of junior high school (Kvaslund, 2000; cited in Tilleczek & Ferguson, 2007; Sutherland, Yee, McNess, Harris, 2010; James, Davison, See & Knowles, 2010); changes in pupils' academic achievement (McGee, Ward, Gibbons & Harlow, 2004; Cox & Kennedy, 2008; Barber & Olsen, 2004; Roeser, Eccles & Samerof, 2000); changes in the child's social relationships, as, for example, relationships with teachers (Eccles, Midgley, Wigfield, Buchanan, Reuman, Flanagan & MacIver, 1993; Cocklin, 1999), in the relationships with peers (Serbin & Bukowski, 2006; Graham & Hill, 2002); and not to forget the physical, physiological and emotional changes that occur in early adolescence (Callagan, Clark & Kellough, 1995; Kroger, 2006; Barrat, 1998).

SELF-CONCEPT AND SELF-ESTEEM

Undoubtedly, the age of child during the transition from primary school to lower secondary education (LSE), is an important index, which affects other indicators. At this age the child has entered into early adolescence. The early adolescence period is one marked by many changes in biological and psychological characteristics and in relations with peers, teachers, etc. (Wigfield, Lutz, & Wagner, 2005, p. 117).

“The biological and social changes associated with puberty may also be responsible for some of these changes in young adolescents' self-perceptions” (Wigfield, Eccles, Mac Iver, Reuman, & Midgley, 1991, p. 552).

But despite the great importance that these changes have for the young adolescents' live, I will not dwell on the biological and cognitive changes occurring in adolescence. In this session, I will focus on the child's value system, which is in the centre of the development in early adolescence. This value system is composed of self-esteem, self-concept and identity (Susman & Rogel, 2004; Harter, 1999; cited in Wigfield, Lutz & Wagner, 2005, f. 112-113). In literature self-evaluation and self-concept are sometimes used in place of each other, but it should be said that they do not represent the same thing, although there are multiple definitions for each of them.

Self-concept is a complex network of interactive self-perceptions that a person holds about his beliefs to the adoption of certain behaviors and to have some personal attributes with cultural value (Gresham, Eliot & Evans-Fernandez, 1993; cited in Christensen, 2007, f. 11). It is classified as a cognitive science that organizes abstract and concrete views about yourself and controls the processing of information of the self-belonging (Kihlstrom & Cantor, 1983; cited in Man, Hosman, Schaalma & Vries, 2004, p. 357). Or, more succinctly: self-concept relates to individual beliefs and estimates about characteristics, roles, skills and his relationships (Wigfield, Lutz &

Wagner, 2005, f. 113). Other concepts that are mentioned in the literature as self-image and self-perception, are equivalent to the self-concept (Mann, Hosman, Schaalma & Vries, 2004, p. 357).

While *self-esteem* is the feeling that one individual has for him/herself or values as a person. It is the way you see yourself and how you feel about things you do (Wigfield, Lutz & Wagner, 2005, f. 113; Nemours from kidshealth.com). Self-esteem is the evaluation and affective dimension of self-concept and it is considered the equivalent of self-belonging and self-value (Harter, 1999; cited in Mann, Hosman, Schaalma & Vries, 2004, p. 357).

Identity is the conscious description of an individual of who he is. If you want to know the identity of a person, ask the person to describe himself (Chapter 15, f. 317). Identity is a broader term than self-concept and self-esteem and refers to the individual's feelings about himself and his psychological reality that includes several different beliefs and attitudes (Wigfield & Wagner, 2005; cited in Wigfield, Lutz & Wagner, 2005). The formation of identity involves not only the success in activities such as: school achievement, social relationships with others, career interests and choices, the exploration in the different roles, but it also involves sexual orientation, gender and ethnic factors (Harter, 1999; Marcia, 1980; Waterman, 1982; cited in Wigfield, Lutz & Wagner, 2005). For example, a person who has a religious identity with important content and purpose, it is very clear for him what to do, what to assess and how to behave (Oyserman, Elmore, & Smith, 2012, f. 73).

Types of self-concept

Self-concept is composed of real self, ideal self and public self.

Real self is how you see yourself. This could be real or not. People can see themselves much better than they actually are and in contrary they may perceive too much flaw and weakness, thus having a negative self-image of themselves. For example, a teenage boy may perceive himself to be stupid and not likeable to society, when in fact he is very nice and kind. Or, often, teenage girls believe they are overweight when in reality they are slim (Rogers, 1959).

Ideal self is what a person would like to be, such as a good, moral, and well-respected person. The conflict that sometimes occurs between the real self and the ideal self can positively affect if we motivate a person to improve, in order to approximate the ideal image of himself, or it could be the cause to experience anxiety and danger, when ideal self is far away and is not accessible to realized by the person (Chapter 15, f. 317).

While *public self* is what a person thinks about what others think of him, and public self influences the real and ideal self. When these three components of self-concept are in resonance with each other, then the self-concept and mental health of the person are positive (Chapter 15, f. 317).

THE DEVELOPMENT OF SELF-CONCEPT AND SELF-ASSESSMENT FROM INFANCY TO ADOLESCENCE

Harter (1990) explained that educational and development researchers, often measure self-concept with the competencies or skills of the child to do things. Young children have developed self-concept and have clearly expressed it when they show their skills in different areas (cited in Wigfield, Lutz & Wagner, 2005, p. 113-114).

But at what age children are able to self report their self-concept? To measure the self-concept of the children, researchers are focused primarily on children's abilities to describe and to rank themselves through multiple dimensions. Marsh, Barnes, Cairns, & Tidman, (1984) have argued that children are able to report various dimensions of self-concept since they are in second grade of primary school (cited in Oyserman, Elmore, & Smith, 2012, p. 76).

By the transition from primary to lower secondary education, students' self-concept decreases. The reason for this decline is the different levels of perception of children's self-concept. When they are younger, the self-concept that they have for themselves, is much more positive than the powers they really have, which means that they overestimate their abilities. According to researchers, this overestimation happens because the children have not developed enough critical assessment of themselves and they are not able to integrate information from multiple sources. Growing up, pupils understand better how their skills are viewed by others, being so more careful in their self-perception. During the transition to secondary education, levels of self-concept of children are lower than in childhood. According to Harter's opinion, it passes by the start of secondary education, where adolescents' self-concept begins to rise gradually (Harter, 1999; cited in Manning, 2007, p. 11).

The researchers believe that self-esteem with all its components, is not fully developed in early childhood. General self-esteem as the self-concept, is fully developed in the middle childhood. Young children are able to judge their skills in some specific areas, but they do not have the ability to make general judgments about their self-value (Harter, 1999; cited in Bos, Muris, Mulken & Schaalma, 2006, p. 4).

Who can influence in the development of positive self-concept of children and how this can be realized?

The crucial role for the development of infants' positive self-esteem, belongs to parents, which promote self-esteem of their children by encouraging them to take initiatives (to speak, to crawl), congratulating for every good action, smiling and proudly watching. With the growth of the child, the circle and contacts with others expand. Now, other characters enter on stage, as peers, educators, teachers, trainers, orienting the child to do useful things for him/her self. All these people help the child to see himself in a positive manner, boost self-confidence that he/she can succeed even when things are going in the wrong way (Nemouros, kidshealth.org).

When children enter in adolescence (this is the age when they start secondary education), self-esteems become more visible, more separated and some not so important issues in childhood, begin to take importance, as for example the influence of peers, romantic relationships or job competencies (Harter, 2003; cited in Bos, Muris, Mulken & Schaalma, 2006, p. 4). In addition, another reason that makes a difference in self-esteem among adolescents in this period, is also the importance of peer approval. This index together with parenting style becomes an important predictor of self-esteem in adolescence. It is very important what others think about the person and children catch more easily the opinion that others have for them. For example, the thoughts that people who care for children and other adults with influence on them, have for them (Leary & Mac Donald, 2003; cited in Bos, Muris, Mulken & Schaalma, 2006, p. 4).

Literature has defined the characteristics of parenting that strongly influence the development of child's self-esteem. The opportunity to build positive and high levels of self-esteem, is too large at parents who are approving, nurturing and responsive. While disapproving, uninterested and unresponsive parents, adversely affect and may break down the child's self-esteem levels (Bos, Muris, Mulken & Schaalma, 2006, p. 4).

THE IMPORTANCE OF SELF-ESTEEM AND SELF-CONCEPT IN THE CHILD'S LIFE

What positive self-esteem and self-concept develops in children? All children have a positive self-esteem for themselves. To develop this further, it helps kids keep their heads up, they feel proud of themselves, urge to try new things and add confidence in themselves. Through positive self-esteem, the child develops a high self-esteem for himself, and in this way, others begin to have respect for him; it helps children to be objective and choose healthy alternatives for their mind and body (Nemouros, kidshealth.org).

Positive feelings of self-esteem affect in the growth of children's confidence and in their academic success, for example, enhance the ability to read (Coopersmith, 1967, Marcus & Nurius, 1986, cited in Mann and tj., 2004, p. 359). Dominant strongest predictor of happiness is seen to be self-esteem (Furnham & Cheng, 2000), which together with self-concept and identity are among the key elements of mental health. Our welfare, mental well-being, adjustment, happiness, success and satisfaction, are strongly associated with positive self-esteem. Even healing some serious diseases, depends heavily on positive self-esteem (Chang & Mackenzie, 1998; cited in Mann and tj., 2004, p. 359).

Whereas self-concept is very important for the person, that his happiness and success in life depend on it. As we highlighted above, self-concept can be positive when people believe in themselves, set goals that can be achieved and self-improved. Several times people with positive self-concept, may also give up some life habits and choose alternatives that preserve their health, for example, when people quit of drinking, smoking (Chapter 15, p. 317). During the transition to Junior High School, promoting a high self-concept of young adolescents, increases academic and life success (Manning, 2007, p. 11).

THE EFFECTS OF SCHOOL TRANSITIONS IN SELF-CONCEPT AND SELF-ESTEEM OF PUPILS

Outcomes from the research literature clearly show that the entry of children in early adolescence, which coincides with the transition of children from primary to lower secondary education, self-esteem and self-concept of children decrease. Studies of the last two decades have shown that changes in self-concept and self-esteem of the child are strongly correlated with changes in student academic achievements (Marsh, 1990; Ssu-Kuang, Ju-Chen, Fang-Ming & Sunny, 2013; Gniewosz, Eccles & Noack, 2011). According to the researchers, the students at risk for low self-concept and for its negative consequences, are those experiencing strong academic difficulties (Elbaum & Vaughn, 2001; cited in Christensen, 2007).

Evidence about changes in self-concept of students in various skills, have brought studies by Eccles et al., (1989), Wigfield et al., (1991), Jacobs et al., (2002), which have reported decreasing self-esteem of pupils immediately after school transition.

Eccles, Wigfield, Flanagan, Miller, Reuman, & Yee (1989) aimed to study the self-concept of pupils about their skills in two major subjects: English and Maths, and how it develops during the transition to Junior High

School. The same interviewed students twice in sixth grade and twice in seventh grade showed that beliefs in their English and Maths abilities, decreased during the transition (cited in Eccles & Wigfield, 2000, p. 155).

The study conducted by Wigfield, Eccles, Mac Iver, Reuman, & Midgley (1991), expanded fields to measure the academic self-perception of children not only in English and Maths, but also in social and sports activities, as well as on self-evaluation. The large number of the study population (N=1850), allowed researchers to make significant generalizations regarding academic self-perception and self-esteem of pupils during the transition to junior high school. Pupils completed the questionnaires twice a year (in spring and winter of the grade 6th and 7th). Results of the study showed that children's self-esteem was lower immediately after the transition, which means in the end of the first semester of 7th grade. This self-esteem, although growing in 7th grade, showed lower levels of self-esteem that these students have had in the 6th grade before the transition. While beliefs about pupils' abilities in Maths, English, and social activities, strongly declined between the end of 6th grade and first semester of 7th grade, but the perception of social skills increased during 7th grade. Perceptions about sport activities decreased during the transition from grade 6 to 7. Like Maths' skills, as well as sports' skills decreasing all the time. Some of the reasons for these declines in academic self-perceptions, were attributed to the differences between environments of primary school and junior high school, by the researchers.

The study undertaken by Jacobs, Lanza, Osgood, Eccles, & Wigfield (2002), who examined changes in beliefs and values of the competence of children from classes 1 to 12, had the same objective but with a much wider range of school years. The findings supported the results of previous studies, concluding that there was a decline in Math, Language Arts and Sports competencies. The strongest decline in Language Arts was marked during the elementary school years, and later it have had slight decreases; declines in Math competencies were similar at all times, while the largest decreases in Sport activities was recorded during the high school years (cited in Wigfield & Tonks, 2002, p. 60).

Toking & Watt (2003) aimed to evaluate the effectiveness of a transition program to self-concept of students in grade 7, by comparing two groups of students: one group was included in the program (No = 47 girls) while the other was not (No = 76 girls). Results indicated that the transition program did not increase student's self-concept levels. Thus, students who continued Junior High School in the same building where they had finished elementary school, had highest self-concept in school competencies and social acceptance than the new students to the school, immediately after the transition. Measurements, which were repeated after 5 months of transition, (in the middle of the academic school year) indicated again that self-concept for social acceptance and academic competencies reached even higher levels than the first measurements. The researchers explained that the maintainance high levels of self-concept in 7th grade, occurred because of the silence that students felt in familiar surroundings and known people for them. While physical appearance, behavior and self-value did not mark statistical differences between those who continued in the same school and those transferred to another school. Perhaps these factors of self-concept do not present dependence from known environments and peer influences.

The different school environments that children found passing from one school to another, complicated the adaption of the children at Junior High School (Tilleczek & Ferguson, 2007). School transition issues plus students' cultural and ethnic factor, and comparison of students with different cultural backgrounds, has been the object of the study of Graham & Hill (2003) in the UK. Results of the study showed some differences between the two-thirds of the children in seventh grade, who identified themselves as white, and one third of students who were of Pakistani Muslim background. Despite the fact that ethnic minority showed a generally positive attitude towards the transition from grade seven of elementary to grade eight of secondary school, and despite the fact that the anxiety of starting a new school disappeared after almost a month, students reported other difficulties. Thus, "about one in ten children with Muslim faith indicated that their school did not allow them to follow their religious beliefs as they wished (e.g. not being able to pray at the appropriate time)". Other difficulties were changes of ethnicity, religion, school dimension, behavior, dressing, the lack of fluency in communication in English language with white peers, also with teachers.

Beside the changes that education researchers have found between environments of primary and secondary school, other factors such as cultural background, socio-economic status, ethnicity, etc., students bring with them into the classroom, and their combination, are seen as risky contexts in school transition (Tilleczek & Ferguson, 2007, p. 17). For examination of these risky factors and their impact on students' self-esteem, a study was undertaken by Rhodes, Roffman, Reddy, & Frederiksen (2004), which measured the interactions between individual and context variables and effects they had in initial self-esteem and its performance during the junior high school years. This 3 year long-lasting study involving a large number of students (No=1804), used Hierarchical Linear Modeling (HLM) techniques to measure students' self-esteem. Results indicated that the interactions between race, social class, socio-economic status of the school and contextual congruity were found to be influential. According to Rhodes et al., (2004) young people with low incomes consistently experienced

lowest self-esteem levels and the sharpest declines during the middle school years. Social disagreements were the main cause of such loss.

CONCLUSIONS

School transitions strongly influence not only in the outer issues of the student, which include educational challenges, academic, organizational, geographical and cultural differences, but also in the internal issues of the students, which include individual changes that occur within the child during and after the transition. One of these individual internal changes is self-esteem and self-concept that student has for himself and for his achievements.

Sometimes in literature, self-assessment and self-concept are used in place of each other, but they do not represent the same thing. Children are fully responsible to report on multiple dimensions of self-esteem and self-concept when they reach middle childhood. The studies bring evidences of a strong correlation between the transition and students' self-esteem and self-concept, highlighting the decline of both these indicators during the transition from primary to Junior High School.

Maintaining a high and positive students' self-esteem and self-concept, impact increasing children's confidence and their academic success; makes students feel proud of themselves, encourages them try new things; develops a high self-esteem for themselves, and in this way, others begin to have respect for them; ensures optimum mental health, maintaining a mental well-being, adjustment, happiness, success and satisfaction, even curing some serious diseases; helps children to be objective and choose healthy alternatives for their mind and body.

Therefore the task of teachers, parents, policy makers in education, education researchers, etc., is to build school environments, curriculums, and transition programs that help students maintain higher levels of self-esteem and their self-concept.

REFERENCES

- Barber, B. K. & Olsen, J. A. (2004). Assessing the transitions to middle school and high school. *Journal of Adolescent Research*, 19, 3-30.
- Barratt, R. (1998). *Shaping middle schooling in australia. A report of the National Middle Schooling Project*. Canberra, Australia: Australian Curriculum Studies Association.
- Bos, A. E. R., Muris, P., Mulken, S., & Schaalma, H. P. (2006). Changing self-esteem in children and adolescents: A roadmap for future interventions. *Netherlands Journal of Psychology*, 62, 26-33.
- Callagan, F. J., Clark, H. L., Kellough, D. R. (1995). *Teaching in the middle and secondary schools*. Fifth edition, New Jersey.
- Chang, A. M. and Mackenzie, A. E. (1998). State self-esteem following stroke. *Stroke*, 29, 2325-2328.
- Christensen, E. J. (2007). *Female adolescents identified with emotional disturbance and adjudicated female adolescents: A comparison of self-concepts*. Dissertation Prepared for the Degree of Doctor of Philosophy. University of North Texas.
- Cocklin, B. (1999). *A journey of transition: From Gumly Gumly public to secondary school*. Wagga Wagga: Charles Sturt University. publications.aare.edu.au/99pap/coc99595.htm
- Coopersmith, S. (1967). *The Antecedents of Self Esteem*. Freeman, San Francisco, CA.
- Cox, Sh. and Kennedy, Sh. (2008). *Report No. 1. Students' Transition from Primary to Secondary Schooling Study*. Ministry of Education. Wellington, New Zealand.
- Eccles, S. J. & Wigfield, A. (2000). *Schooling's Influences on Motivation and Achievement. Securing the future: Investing to children from birth to college*. S. Denzinger and T. Waldfogel. New York, Russell Sage Foundation (pp. 153-181).
- Eccles, S. J., Midgley, C., Wigfield, A., Buchanan, M. Ch., Reuman, D., Flanagan, C., & MacIver, D. (1993). Development During Adolescence: The Impact of Stage-Environment Fit on Young Adolescents' Experiences in Schools and in Families. *American Psychological Association*, 48 (2), 90-101.
- Eccles, S. J., Wigfield, A., Flanagan, C., Miller, C., Reuman, D., & Yee, D. (1989). Self-concepts, Domain Values, and Self-esteem: Relations and Changes at early Adolescence. *Journal of Personality* 57(2), 283-310.
- Elbaum, B., & Vaughn, S. (2001). School-based interventions to enhance the self-concept of students with learning disabilities: A meta-analysis. *The Elementary School Journal*, 101(3), 303-329.
- Furnham, A. and Cheng, H. (2000). Lay theories of happiness. *Journal of Happiness Studies*, 1, 227-246.
- Gniewosz, B., Eccles, S. J., & Noack, P. (2011). Secondary School Transition and the Use of Different Sources of Information for the Construction of the Academic Self-concept. *Social Development* (pp. 1-21). Blackwell Publishing Ltd.
- Graham, C. & Hill, M. (2002). *The transition to secondary school. Report of a study funded by the Esme fairbairn charitable trust*. Glasgow centre for the child & society. University of Glasgow. Scotland, U.K.

- Gresham, F. M., Elliott, S. N., & Evans-Fernandez, S. E. (1993). *Student self-concept scale manual*. Circle Pines, MN: American Guidance Service, Inc.
- Harter, S. (1990). Causes, correlates and the functional role of global self-worth: A life-span perspective. In J. Kolligian & R. Sternberg (Eds.), *Perceptions of competence and incompetence across the life-span* (pp. 67–98). New Haven, CT: Yale University Press.
- Harter, S. (1999). *The construction of the self: A developmental perspective*. New York: Guilford.
- Harter, S. (2003). The development of self-representations during childhood and adolescence. In M. R. Leary and J. P. Tangney, *Handbook of self and identity* (pp. 610-642). New York: The Guilford Press.
- Jacobs J. E., Lanza, S., Osgood, D. W., Eccles, J. S., Wigfield, A. (2002). Changes in children's self-competence and values: gender and domain differences across grades one through twelve. *Child Development*, 73(2): 509-27.
- Kids Health. *The story on self-esteem*. Nemours. kidshealth.org
- Kihlstrom, J.F. and Cantor, N. (1983) Mental representations of the self. In Berkowitz, L. (ed.), *Advances in Experimental Social Psychology*. Academic Press, San Diego, CA, vol. 17, pp. 1–47.
- Kroger, J. (2006). *Identity in Early Adolescence*. Chapter 2. Sage Publications, 33-58.
- Kvalsund, R. (2000). “The Transition from Primary to Secondary Level in Smaller and Larger Rural Schools in Norway: Comparing Differences in Context and Social Meaning”. *International Journal of Educational Research*, Vol. 33(4), 401-424.
- Leary, M. R., & Mac Donald, G. (2003). Individual differences in self-esteem: A review and theoretical integration. In M. R. Leary and J. P. Tangney, *Handbook of self and identity* (pp. 401-420). New York: The Guilford Press.
- Mann, M., Hosman, H. M. C., Schaalma, P. H. and de Vries, K. N. (2004). Self-esteem in a broad-spectrum approach for mental health promotion. *Health Education Research, Theory & Practice*. Vol.19 (4), 357–372. Downloaded from <http://her.oxfordjournals.org>
- Manning, A. M. (2007). Self-concept and self-esteem in Adolescents. *Student Service* (p. 11-15). www.uasponline.org/families/selfconcept.pdf
- Marcia, J. E. (1980). Ego identity development. In J. Adelson (Ed.), *Handbook of adolescent psychology* (pp. 159–187). New York: Wiley.
- Markus, H., & Nurius, P. (1986). Possible selves. *American Psychologist*, 41, 954–969.
- Marsh, H. W. (1990). Influences of internal and external frames of reference on the formation of math and English self-concepts. *Journal of Educational Psychology*, 82(1), 107–116.
- Marsh, H. W., Barnes, J. Cairns, L., & Tidman, M. (1984). Self-Description Questionnaire: Age and sex effects in the structure and level of self-concept for preadolescent children. *Journal of Educational Psychology*, 76, 940-956.
- McGee, C., Ward, R., Gibbons, J. & Harlow, A. (2004). *Transition to Secondary School: A Literature Review*. The University of Waikato. Hamilton. New Zealand. www.minedu.govt.nz
- Oyserman, D., Elmore, K., & Smith, G. (2012). Self, Self-Concept, and Identity. In Leary, R. M. & Tangney, P. J. *Handbook of Self and Identity. Second Edition*. Chapter 4, p. 69-104. New York: The Guilford Press.
- Rhodes, J., Roffman, J., Reddy, R., & Fredriksen, K. (2004). Changes in self-esteem during the middle school years: a latent growth curve study of individual and contextual influences. *Journal of School Psychology* 42: 243–261.
- Roeser, R. W., Eccles, J. S., & Sameroff, A. J. (2000). School as a context of early adolescents’ academic and social-emotional development: A summary of research findings. *The Elementary School Journal*, 100(5): 443-471.
- Rogers, C. (1959). A Theory of Therapy, personality and Interpersonal Relationships as Developed in the Client-centered Framework. In (ed) S. Koch, *Psychology: A study of Science*. Vol. 3: Formulations of the Person and the Social Context. New York: McGraw Hill. http://psychology.about.com/od/profilesofmajorthinkers/p/bio_rogers.htm
- Serbin, A. L. & Bukowski, M. W. (2006). *The Transition from Primary To Secondary Schooling: Strategies For Success In Vulnerable Populations*. Final Report (FQRSC). Centre for Research in Human Development. Concordia University. www.cengagesites.com/academic/assets/sites/pdf
- Ssu-Kuang, Ch., Ju-Chen, j., Fang-Ming, H., & Sunny, S. J. (2013). The relationship between Academic Self-concept and Achievement: A Multicohort-Multioccasion Study. *Learning and Individual Differences*. 23, 172-178.
- Susman, E. J., & Rogel, A. (2004). Puberty and psychological development. In R. M. Lerner & L.D. Steinberg (Eds.), *Handbook of adolescent psychology* (2nd ed., pp. 15–44). New York: Wiley.
- Sutherland, R., Yee, Ch. V., McNess, E., Harris, R. (2010). *Supporting learning in the transition from primary to secondary school*. Final Report, University of Bristol.
- Tilleczek, K. & Ferguson, B. (2007). *Transitions and pathways from Elementary school to secondary school: A review of selected literature*. Community Health Systems Resource Group The Hospital for Sick Children For the Ontario Ministry of Education Toronto, Canada. Nga

- Tonkin, S. E. & Watt, M. H. (2003). Self-concept over the transition from primary to secondary school: a case study on a program for girls. *Issues in Educational Research*, 13. From: <http://education.curtin.edu.au/iier/iier13/tonkin.html>
- Waterman, A. (1982). Identity development from adolescence to adulthood: An extension of theory and a review of research. *Developmental Psychology*, 18, 341–358.
- Wigfield, A. & Tonks, S. (2002). Adolescents' Expectancies for Success and Achievement Task Values during the Middle and High School Years. In F. Pajares & T. Urdan. *Achademic Motivation of Adolescence*. Chapter 3. Information Age Publishing Inc. USA. P. 53-82.
- Wigfield, A., & Wagner, A. L. (2005). Competence and motivation during adolescence. In A. Elliott & C.Dweck (Eds.), *Handbook of competence and motivation* (pp. 222–239). New York: Guilford Press.
- Wigfield, A., Eccles, J. S., Mac Iver, D., Reuman, D. & Midgley, C. (1991). Transitions During Early Adolescence: Changes in Children's Domain-Specific Self-perceptions and General Self-esteem Across the Transition to Junior High School. *Developmental Psychology*, 27(4): 552-565.
- Wigfield, A., Lutz, L. S. & Wagner L. A. (2005). Early Adolescents' Development Across the Middle School Years: Implications for School Counselors. *Professional School Counseling*, 9(2), 112-119.

ASSESSING THE CLIMATE FOR CREATIVITY IN MATHEMATIC'S LESSONS

Alexandre Tolentino de Carvalho
Universidade de Brasília
Alexandre.tolenca@gmail.com

ABSTRACT: In relationships established at school, it creates an psychological climate in this environment that can both promote the development of the creative potential of individuals, as may hinder it. However, in the literature consulted, lacks empirical studies that address the constituent factors of the classroom climate for creativity in mathematics and there are no validated instruments to measure statistically this climate. This article describes an empirical-analytic study realized with 324 students from public and private schools in the age range from 9 to 14 years devoted to understanding the factors present in the formation of the classroom climate for creativity in mathematic's lessons. Shows the Scale of Climate for Creativity in Mathematics lessons, instrument resulting from this study that serves as a tool for teachers, managers, researchers and students can assess strengths and weaknesses involved in the constitution of the favorable climate to creativity in mathematic's lessons.

Key words: creativity in mathematics, mathematics education, classroom climate for creativity

INTRODUCTION

It seems consensus among researchers in mathematics education that math abilities are not worked in their completeness and, apparently, logical scholastic abilities, linked to convergent thinking, receive priority in lesson plans at the expense of abilities that require more time and more attention from the teacher in the direction both to research, to plan, to elaborate and to monitor the development of these classroom. As a result, the attitudes of students with mathematical knowledge become more automated and less reflective.

For example, we can take the studies of Haylock (1997) who noticed that there is a tendency among students of content-universe fixation (i.e., their thoughts about a problem are restricted to a variety of inadequate or inappropriate elements) and algorithmic fixation (in which they adhere to a routine or stereotyped response, even when it becomes inefficient or inappropriate for the problem at question). Then Haylock proposes that overcoming this rigidity of thought may be relevant a aspect for the mathematical problem solving.

Also in this sense, Valdés (2010) identifies that many teachers, guided by a purely formal conception of the nature of mathematics, consider that this school discipline should devote themselves to develop ways of thinking linked to logical thinking. When referring to logical thinking, the author try to define those forms of reasoning developed by the teacher in which he prioritizes convergent thinking, ways of acting "associated with formal thought" (Valdés 2010, p. 8) and comprising inductive, deductive and analogy reasoning. However, the author points out that having a well-developed logical thinking is insufficient for solving mathematical problems that require abilities that go beyond logical thought, i.e., that require a "high dose of imagination, fantasy and creativity" (p. 6).

Logically, these authors are referring to the development of creative skills in math classes, one facet of school mathematics that has been neglected when the teacher prioritizes the indiscriminate use of formulas, algorithms and hard thinking in which you teach, you learn and reproduces only forms of mathematical problem solving. Krutetskii (1978) already demonstrated that mathematics developed in the school presented problems that required students both the domain of logic, i.e., essential algorithms for solving mathematical problems of most, as the domain of creative skills necessary for solving problems which could not be resolved by means of algorithms. However, at present, we still find kinds of problems at schools which, according to Piggott (2007), restrict themselves to address a context that is very familiar to the student, almost always portraying a mathematical concept they have just learned and that nothing brings of challenging, they are given clear clues about the knowledge to be applied to its resolution.

There is not doubt among researchers that the development of the creative potential of students need to be part of the agenda of mathematics abilities to be developed at school space. Fleith (2010) states that one of the environment most investigated in research related to creativity is the school. Being an environment made up of people who are related to each other and relate to mathematical knowledge, is eventually developed a climate in this environment that can both promote the development of creative potential that each individual carries, as the can serve as a barrier that prevents creativity to flourish in this space. As remembered by the author, "the

cultural environment has a strong influence on creativity by supporting or inhibiting the development of creative effort" (Fleith 2011, p. 3).

Fernandes (2008) recalls out that in the classroom "converge personalities, motivations and capacities very disparate, not being, therefore, easy to create and nurture relationships of affection, affection and friendship, if there is a good climate of acceptance for differences and mutual respect "(p. 16). Therefore, to study how it organizes the climate of the classroom and, specifically, studying the climate for creativity in mathematics lessons, it is necessary to focus both on the environment as in the people who relate that environment. However, much of the research focuses on identifying talented individuals through application testing and individualized description of the individual's role components of the school room for the creativity to emerge in math classes. In the literature consulted, there aren't empirical studies that specifically address the environmental factors that influence the development of creative abilities in mathematics, nor were found statistically validated instruments to measure climate specifically in mathematics lessons.

Taking into account the importance of undertaking research related to climate for creativity in mathematics classrooms and the lack of studies and measurement instruments of this climate specific in this area of education, this paper is devoted to describe a study conducted in the years 2013 and 2014 with students in the age range 9 to 14 years in search of analyzing the factors and dimensions involved in shaping the climate of the classroom for creativity in mathematics lessons and to present, alternatively for measuring these factors, the Scale Climate for Creativity in Mathematics Lessons, instrument resulting from these studies.

To build an understanding of the climate for creativity in mathematics classes were consulted 5 major areas involving literature on climate of the classroom (Brunet, 1992 and Fernandes, 2008; Rodrigues Garran, 2004; Çagran & Schmidt, 2006), Climate for creativity in the classroom (Alencar, 2007; Amabile et al, 1996;. Fleith & Alencar, 2005) and climate in mathematics lessons covering psychological climate in mathematics lessons (Haladyna, Shaughnessy & Shaughnessy, 1983) and social representations in mathematics. (Ramos, 2004). The consultation of literature also encompassed studies on creativity (Alencar & Fleith, 2003; Amabile, 1983; Csikszentmihalyi, 1996; Lubart, 2007; Simonton, 1988; Sternbert, 1991) and on creativity in mathematics (Balka, 1974; Gontijo, 2007; Hadamard, 2009/1963; Hashimoto, 1997; Haylock, 1987, 1997; Kattou 2012; Krutetskii, 1976; Poincaré, 1908). For the sake of synthesis, we won't address the contributions of all these scholars. However, we point out some basic points essential to understanding how we conceive understandings of the climate for creativity in mathematics lessons.

We can also point out the contributions of Brunet (1992) as included in the first area of knowledge, i.e., studies on climate of the classroom. He defends that "organizational climate is the perceptions of school actors in relation to existing practices in a such organization" (in Santos 2010, p. 42). He pointed three variables as determinants of the constitution of the climate of the classroom: (a) the structure: are the physical characteristics of the organization described, for example, in school curricula; (b) the organizational process: the way how one performs the management of human resources, for example, the way in which conflicts are resolved, the policy of rewards and the way in which it organizes educational project; (c) behavioral variables: modes of individual and group organizations. The results of these dimensions are: for the individual is reflected in the level of satisfaction on their income and quality of life; for the group is the cohesion, morale and results; and the organization is educational performance, efficacy, adaptation and evolution.

Fernandes (2008) remind out that a large number of authors defend that the interactions between teacher and students are crucial to the constitution of the atmosphere of the classroom. However, this interaction is seen as essentially asymmetrical depending mostly of the actions of the teacher and to a lesser extent the action of the students. This fact is due to the teacher's rigid posture which expects students to adapt to their way of teaching. In this optical, it becomes clear the important role of the teacher who constitutes a determinant in the process of drafting the climate of the classroom. However, it must be focus that the teacher's role is crucial, but not sufficient, since both the student "devout" as "resigned" and still "revolted" (Amado, 2001, cited in Fernandes, 2008, p. 14) form part of these interactions not always acting passively.

In the second area of the literature, we analyzed the contributions about climate of classroom for creativity. A current and important work related to climate for creativity in classroom can be attributed to Fleith (2010). The author presents the scale Climate for Creativity in the Classroom (Fleith & Alencar, 2005) constructed to assess the climate for creativity in the classroom and validated through factor analysis, where he uses a sample of students in 3rd and 4th-graders (currently 4th and 5th year of primary school). Items are answered through a frequency range of five points, ranging from never to always and are distributed into five factors: support from teacher to student's expression of ideas (consists of 5 items that relate to the support provided by the teacher to which the student can to express your opinion); perception of the student with respect to creativity (contains 4 items related to the image that the student creates about his performance on with regard to creativity); student interest in learning (consists of 6 items that shows the student engagement with the learning process); learner autonomy (displays 4 items corresponding to a personality trait associated with creativity); stimuli from the teacher to the student's production of ideas: composed of 3 items related to attitude of acceptance and

encouragement from teachers to the ideas developed by the students. Fleith (2010) observes that the factors this scale lend themselves to evaluate both teacher behaviors that are conducive to the expression of student creativity, as the student characteristics related to creativity.

The discussion about climate in Mathematics lessons, i.e., the third area of literature consulted, was conducted with the use of elements present in studies searching to understand the psychological climate in this area of knowledge and in studies related to social representation in Mathematics. Articulated themselves those elements using up the contributions from each of these studies in order to build an understanding of the climate in mathematics lessons and consequently walked to the conclusion about the climate for creativity in mathematics lessons.

Haladyna, Shaughnessy and Shaughnessy (1983) developed a study wherein elaborated a hypothetical model in which the factors teacher quality, socio-psychological climate of the classroom and climate of the management/organization of the classroom were used to measure attitude toward mathematics of students in the 4th, 7th and 9th grades. Authors define attitude towards mathematics as a general emotional disposition for the school subject of mathematics, valued for to be a important result to the school itself, often by being positive slant and slightly related to the success and power increase tendency to elect mathematics as a career possibility in this field. Therefore, the authors focused on the analysis of endogenous factors to the classroom, postulating that "the development of attitudes toward mathematics is likely to be influenced by the teacher and the learning environment (sometimes referred to as climate variables in classroom)" (p. 20).

Another source of study of which one can get elements to be understanding about climate in mathematics lessons can be found in research on social representations in mathematics. Ramos (2004) developed a study that shows concern for the lack of success in this discipline wherein students, besides having poor results in tests and examinations held during their school career, also shows disinterest with discipline. Another concern raised by the author concerns the fact that, despite technological advances facilitate the tasks of calculations, in conceptual terms, the requirements have become increasingly mathematicized requiring a set of mathematical abilities that go beyond the activities of calculations and pass more by "making decisions, by defining strategies to follow to solve a problem, by a critical perspective in face to the results obtained which allow completed by her reasonableness, or not, by the interpretation of graphs and tables, etc." (Ramos, 2004, p. 71).

The author has in these concerns the motivating issues that led her to analyze social representations in the mathematics building an analysis model consists of four dimensions that interpenetrate: affective (relationship of students with the discipline at the level of affection including the importance given to success in mathematics, the affective relationship with mathematics, perception of abilities with mathematics and the image of a good student with Mathematics), social (aspects that concern to the social environment in which students are inserted such as the importance given by parents to success in mathematics, the importance given by friends to succeed in mathematics and the relationship of the group of friends with Mathematics), academic (school experiences of students such as vision relative at the ease of getting good results in Mathematics and relationship with the teacher) and instrumental (including expectations and convictions about the benefits arising from mathematical knowledge as view of the usefulness of school mathematics).

Ramos resorted at the contributions of Durkheim (1968), Moscovici (1976) and Bourdieu (1972) to substantiate the perspective of social representations used in the research he has done. There by, this perspective of social representations understands that "individuals, not being a mere receptacle of images, when interpret, organize and relate what comes to them from abroad, are themselves to be responsible for new creations" (Ramos, 2004, p. 72). The author continue admitting which also in the Mathematics the individual is not restricted to passively internalize the information, it modifies and creates new representations. Based on these considerations, the author defines social representations as "symbolic tools that give meaning to the information that comes to us coming from social reality, organizing her and using her as a guide to action" (Ramos, 2004, p. 74).

The researchers who are dedicated to studying creativity in the systemic approach show the importance of the environment for the development of creativity and constitute the fourth research area used for understanding the climate for creativity in mathematics lessons. Amabile (1983) reveals the importance of the influences of the social environment for the development of motivation, attitudes and abilities. Csikszentmihalyi (1988) develops all a definition about the social and cultural means where creativity occurs may inhibit or stimulate the creative activity of the individual. Sternberg and Lubart (1991) is referring to the environmental context as an important factor for the development of creativity favoring the generation of new ideas, encouraging and supporting the generation of creative products and evaluating the creative product. Simonton (1988) assesses creativity as a social phenomenon which should be studied through investigation the influences of social, political and cultural variables and which cannot be understood outside of the social context in which it occurs.

The fifth and final area of knowledge consulted refers to creativity in mathematics which we have already addressed in the beginning of this introduction. In addition to these points raised, we can mention, for example, Hashimoto (1997) which highlights the importance of to foment the creativity in mathematics in school spaces

through activities that give opportunity for students have different ways of thinking about a problem to be solved.

As previously mentioned, were not found correspondence which concerned to the studies related climate to creativity in mathematics classes. In this logic, looking up theoretical contributions in the contributions discussed earlier to advance in the definitions about climate for creativity in mathematics classes and for the preparation and validation of an appropriate instrument for studies on the subject. For this purpose, it is necessary a articulation retaking key information previously addressed.

First, one can assume the climate for creativity in mathematics classes submerged in emotional-affective structure, starting from the conception of which the school is a meeting place for kids with knowledge. In the case of mathematics, inspired by Krutetskii (1976), the lessons are the moments of meeting the child with school mathematics and with creativity in mathematics, a meeting that takes place in deep interaction between student-student, student-teacher and student-knowledge (in the plural because comes up scholastic abilities and creative abilities in mathematics).

Starting from the contributions discussed above, it is assumed that in the climate for creativity in mathematics, the physical involvement and the structure (like the way which the teacher organizes the space, time and school materials and objects of knowledge to be developed in the planning of the lessons) indicate the resources that contribute to the creation of the enabling environment for creativity. The objectives and the organizational process relate to mode how the mathematics teacher organizes the educational process. The characteristics of the teachers and students, i.e., the behavioral variables relate to the interrelationships that occur in the environment of classroom and ways of behaving before knowledge. Are variables that will determine the way in which the climate of the classroom will enhance the development of creative abilities of students.

The constituent contributions of our study allows us to conclude further that the creation of a climate for creativity in mathematics classes, the perceptions of students about mathematical knowledge are constituted by factors of a social nature in which it give personal relationships, of affective nature wherein the student is related to mathematical knowledge and constitute representations about the degree of importance of the school as environment creativity, of instrumental nature in which the student builds expectations as to such future knowledge, and ultimately of academic nature in which the teacher as an organizer of school space, becomes primarily responsible for managing lessons.

When in the present study is presented the term "Climate for Creativity in Mathematics Lessons", it refers to the confluence of several factors of psychological, social, environmental and structural order that determine the perceptions of the students about the value that is attributed to creative activity in mathematics classrooms and therefore interfere in the itself creative activity of the mathematical subject, considering that these perceptions are converted into bases for the action of the individual perceiver.

These contributions substantiated and resulted in a scale that attempts to assess the perception of students in the 5th grade of elementary school about the climate for creativity in mathematics classes, focusing, therefore, on the environmental factors that influence the development of the creative potential of subject respondents to the instrument. Lubart emphasizes that "the environment evaluates creativity through social judgment" (2007, p.18). Pasquali (2010) reminds us that "assess seems to be a fatality of the human being in relation to its environment, including here, the physical environment and the social" (p.11). Therefore, among the constant human need to evaluate the facts around and considering the importance of social judgments in the constitution of individual perceptions, this scale is based as a useful tool in finding possible negative influences on the incorporation process the perception of the student as the institutionalized medium in which it develops its creative potential.

METHODS

The investigations were guided by an empirical-analytical study preceded by consulting the literature described above, the procedure needed to account to develop and validate a reliable and valid instrument. This sense 53 items were developed initially trying to reflect the aspects mentioned above, structured in a Likert 4-point scale ranging from 1 value, corresponding to the never option, to value 4, related to the always option. The language of the items was constructed by means of affirmatives phrases to ensure comprehension of the respondents seeking also maintain a standardized wording in order to facilitate the reading of sentences and emphasize the fact that participants should evaluate what occurs only in classes mathematics. Still, in order to aid the understanding of participants adapting the instrument to the age of respondents, we sought, through graphics, to represent the values assigned on the scale. Thus, the graphics capabilities represent the gradation extending a figure of a shell of ice cream relating to the value "NEVER", passing a figure of one ball of ice cream relating to the value "A FEW TIMES", another figure of two balls of ice cream concerning the value "OFTENTIMES" and reaching the figure of three balls of ice cream relating to the value "ALWAYS", as shown below:

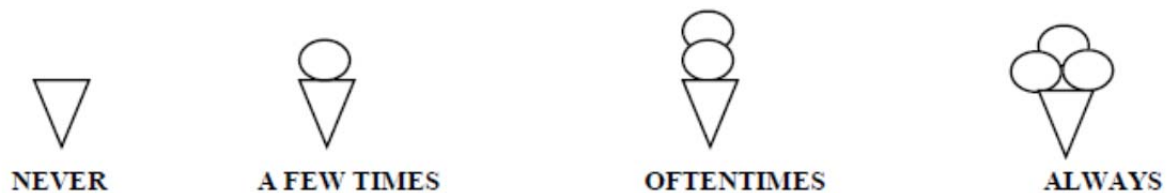

Figure 1 - Graphic Resource of the Scale of Climate for Creativity in Mathematics Lessons

The validation of this instrument took place at three different times required for the scale could actually measure what it is intended of form effective, appropriate and reliable. For that, it was initially consulted a group of experts, after a group of students and finally, we used statistical tools. We present below a brief detail of this process:

- a) The initial analysis was performed by the judgment of a panel of three experts. The role of these experts was constituted in to judge the items as to their purpose of measuring students' perception regarding the climate for creativity in mathematics classes, ie, respond to the questionnaire: the items are able to measure this perception? Items that were considered adequate (although they have been suggested amendments) by at least two experts were included in the version that was subsequently submitted to analysis of the students. After this analysis, changes of terms and suggestions for new items were suggested, getting the version for semantic analysis comprised 55 items in total.
- b) After the evaluation of experts, we proceeded to the semantic analysis, when five collaborators, students in the 5th grade of elementary school to a public school, provided elements for assessing the adequacy vocabulary items to the corresponding age group. According to Pasquali (1999), the items must be formulated with an appropriate language (criterion of clarity) so that they are understood by all members of the population (criterion of credibility). In this analysis step, students showed understanding of vocabulary and no change was realized.
- c) And finally, after the semantic validation, the instrument was administered to a sample of 324 students following the recommendation of Gorsuch (1983) that indicates the application in a sample which represents a proportion of 5 students for each item constant on the scale or a total of at least 200 individuals. Of these students, 200 were enrolled in public schools and 124 in private schools. The reliability of the instrument constituted by factor analysis, at which time it was found their internal structure and extraction of factors was performed. Using the statistical package SPSS version 20.0, conducted an exploratory analysis of data collected in the application of the preliminary version of the scale, proceeding then to the statistical analysis of these data. With the principal components exploratory analysis, we sought to describe and explore the main features of the results and we investigate the presence, in the data collected, of statistical assumptions to demonstrate the possibility of factorability of the instrument.

RESULTS AND FINDINGS

Then we discuss the main results of this empirical research so that, later, we analyze the implications of these results for mathematics education. When performed the extraction of principal components we observed the factorability of the matrix and the possibility of existence of factors. Were pointed favorable index indicative of factorability of the matrix. First, it was pointed the index of sampling adequacy KMO OF 0.801 indicating factorable matrix and optimal adjustment of the sample size given that the literature shows that values above 0.80 are considered great. The analysis of the correlation matrix Anti-image showed diagonal values greater than 0.5 and low values in the rest of matrix which suggests its factorability. The Test of Bartlett's Sphericity ruled out the possibility that the correlation matrix represents an identity matrix (a situation in which the diagonal elements are equal to 1 and the remaining coefficients of the array equal to zero) indicating significant values and a significance level small. Were not found extreme values (0 and 1) in the table of values commonalities, a fact that rules out the existence of problems in factorability matrix.

Darting of the Principal Component Analysis, we estimated the initial number of 19 factors with reference to the Kaiser criterion where the eigenvalue of each factor must be equal to or greater than 1. Taking into account the large number of factors extracted by this criterion, we started to analyze the variance explained by the factor must be at least 3%, which suggested the extraction of 6 factors. Inspection of the Scree Plot graph also suggested the existence of six factors. However, the sixth factor was eliminated by having low reliability index (Cronbach's alpha) and contain only 3 items that did not have a factor loading greater than 0.30 on the other factors. Three items belonging to the other five factors were eliminated for not presenting a theoretical sense to justify the presence of that item in the factor to which it was allocated. This way, after the analyzes, the matrix

gave birth to the scale consisted of 45 items arranged in five factors that explain 33.07% of total variance. The scale called Scale Climate for Creativity in Mathematic's Lessons was constituted as follows:

Compounding Factor 1, we have 11 items that relate to the relationship of the student with mathematics developed in the classroom, where he can express representation that makes this area of knowledge, demonstrating the level of pleasure and performance in this discipline as well as assess their level of creativity in mathematics. In this sense, Gnedenko (1982) shows that students will be creative in mathematics if he likes to math, something that rarely happens in the classroom. So, Factor 1 was named Student's Relationship with Mathematics, with Cronbach alpha index of 0.862. As an example, we mention the items: "The math classes are among my favorite classes" and "I find it easy to learn mathematics."

Factor 2 consists of 16 items and was titled Pedagogical Organization and Creativity in Mathematics. Showed a Cronbach alpha of 0.762 and concerns the perception of students as how the teacher organizes, plans and develops their math classes and how he inserts the development of mathematical creativity of the student in this educational organization. So, covers items that look for evaluate the availability of materials and physical spaces in the development of lessons and variability of pedagogical actions that can stimulate the development of creative strategies for solving mathematical problems. The way the teacher organizes her classes also reflect on how students perceive the usefulness of the knowledge constructed in school will have in your life. Exemplifying this factor we have the items: "The mathematic's lessons take place at various locations of the school (library, gymnasium, garden, patio, etc.)" and "In mathematics classrooms I am encouraged to invent problems."

Factor 3 was named Relationship with Mathematics by to embrace 7 items that relate to the student's perception about the image that colleagues pass of the mathematics and the level of creativity developed in this discipline. then, items seek to evaluate the perception of students about what their peers think about the taste of discipline and the way they evaluate their levels of creativity. The Cronbach alpha index was 0, 731. Items "My colleagues like of mathematics classes" and "My colleagues are creative in Mathematics classes" exemplify this factor.

Factor 4 was comprised of 7 items related to the level of support that the teacher dispenses the production and communication of ideas by the student. The factor was named Teacher's Support at the Production and Communication of Ideas. In this factor, it discusses the evaluation of the student regarding the perception that has on how the teacher plays its role of stimulating production and communication of ideas during math classes, teacher's action that can stimulate the development of the creative potential of students, insofar as these find space to enhance the quantitative and qualitative development of ideas. The index Cronbach alpha was 0.664. The following items are included in this factor: "In mathematics lessons the teacher allows me to ask questions when I have doubts" and "In mathematics lessons the teacher gives me time enough to think about a problem that I have to answer."

The last factor, titled Interaction of Students in Search of Mathematics Strategies, consists of 4 items that look for evaluate the way in which interactions among students in the classroom during the resolution of mathematical activities. As well evidenced by Schoenfeld (2013) learning environments are highly interactive, and ideas that individuals construct are often built and refined in collaboration with others (p.20). This form, this factor is concerned with how to measure how the interactions between students favor the establishment and communication of mathematical strategies, since the joint actions of the students may favor the emergence of creative strategies. The index Cronbach alpha was 0.507. Exemplifying this factor we have the following items: "My colleagues like to do math activities with me" and "My colleagues ask me to help them with math activities."

CONCLUSION

The results suggest that the full development of math abilities in the classroom pass compulsorily by the confluence of several factors if the aim is to educate students proficient in math. Of course this is not a purely mathematical logic, but mainly a mathematical which enables the individual to the full development of their potential, including here the ability to be able to understand their processes of mathematical thinking and problem solving abilities that require more than simple algorithmic procedures.

Based on this concept, the development of the scale grounded in the literature that supports such a view of mathematics education and validated by a rigorous statistical process scale allows us to have at hand a valuable tool with regard to the assessment of the climate of the classroom. Teachers, administrators, researchers, and students themselves can assess the strengths and weaknesses that support for the constitution of the atmosphere that can promote or inhibit the development of the creative potential that each student carries.

RECOMMENDATIONS

The full version of the Scale of Climate for Creativity in Mathematics is designed to be preferentially applied to students enrolled in the 5th grade of elementary school in public and private, educational grade in which students components of the sample of validation instrument schools were enrolled. However, studies can be oriented so as to extend the range for use in other elementary grades. Furthermore, it is recommended further studies in order to improve the scale, both increasing the sample as conducting studies in which the instrument may be tested.

The scale in its full version has the potential to serve as an instrument to measure the perceptions that students make about how creativity is treated in math classes, serving as a means for the teacher to assess their pedagogical action seeking promote the creative potential of their students.

REFERENCES

- Amabile, T. M. (1983). *The social psychology of creativity*. Nova York: Springer.
- Fernandes, L. F. P. (2008). *Clima de sala de aula e Relação Educativa: as representações dos alunos de 3º ciclo*. 2008. 116 f. Dissertação (Mestrado em Observação e Análise da Relação Educativa) - Faculdade de Ciências Sociais e Humanas, Universidade do Algarve, Faro.
- Csikszentmihalyi, M. (1988). Society, culture, and person: a systems view of creativity. In: STERNBERG, Robert J. (Org.). *The nature of creativity*. Nova York: Cambridge University Press., 325-339.
- Fleith, D. S. (2010). Avaliação do clima para criatividade em sala de aula. In: Alencar, e. M. L. S.; Bruno-Faria, M. F.; Fleith, D. S. (Orgs.). *Medidas de criatividade: teoria e prática*. Porto Alegre: Artmed.
- Fleith, D. S. (2011). Creativity in the Brazilian Culture. *Online Readings in Psychology and Culture*, Washington, 4, 3, 1-20.
- Fleith, D. S. & Alencar, E. M. L.S. (2005). Escala sobre o clima para criatividade em sala de aula. *Psicologia: Teoria e Pesquisa*, 21, 85-91.
- Gnedenko, B.V (1982): "Sobre la creatividad Matemática". In: Gnedenko B.V. *Formación de la Concepción del mundo en los estudiantes en el proceso de enseñanza de La Matemática*. Colección Biblioteca del Maestro, Moscol, 94-106.
- Gorsuch, R. L. (1983). Factor analysis (2nd ed.). Hillsdale, NJ: Lawrence Erlbaum Associates.
- Haladyna, T.; Shaughnessy, J.; Shaughnessy, J. M. (1983). A causal analysis of attitude toward mathematics. *Journal for Research in Mathematics Education*, Washington, 14, 1, 19-29.
- Hashimoto, Y. (1997). The Methods of fostering creativity mathematical through problem solving. *International Journal on Mathematics Education - ZDM*, 29, 3, 86-87.
- Haylock, D. (1997). Recognising Mathematical Creativity in Schoolchildren. *International Journal on Mathematics Education-ZDM*, 29, 3, 68-74.
- Krutetskii, V. A. (1976). *The Psychjology of Mathematical Abilities in Schoolchildren*. Chicago: The University of Chicago Press.
- Lubart, T. (2007). *Psicologia da criatividade*. Tradução: Márcia Conceição Machado Moraes. Porto Alegre: Artmed.
- Pasquali, L. (1999). Testes referentes a construto: teoria e modelo de construção. In: PASQUALI, Luiz (Ed.). *Instrumentos psicológicos: manual prático de elaboração*. Brasília: LabPAM/IBAPP.
- Pasquali, L. (2010). *Histórico dos instrumentos Psicológicos*. Disponível Retirado de: <http://pt.scribd.com/doc/64819811/LUIS-PASQUALI>.
- Ramos, M. M. C. (2004). Representações sociais da matemática: a bela ou o monstro? *Sociologia, Problemas e Prática*, 46, 71-90.
- Santos, Clementina de Jesus Alinho dos. Clima escolar e participação docente: a opinião dos professores da educação pré-escolar e do ensino básico. 2010. 214 f. Dissertação (Mestrado em Ciências da Educação) – Faculdade de Psicologia e Ciências da Educação, Universidade de Coimbra, Coimbra, 2010.
- Schoenfeld, A. H. (2013). Reflections on Problem Solving Theory and Practice. *The Mathematics Enthusiast*, California, 10, 9-34.
- Simonton, D. K. (1988). Creativity, leadership, and chance. In Sternberg, R. J. (Org.). *The nature of creativity*. Nova York: Cambridge University Press., 386-426.
- Sternberg, R. J. & Lubart, T. (1991). An Investment Theory of Creativity and its development. *Human Development*, Califórnia, 34, 1-31.
- Valdés, C. E. A. (2010). El Desarrollo de La Creatividad em La Educacion Matemática. Congreso Iberoamericano de Educacion: Metas 2021, Buenos Aires.

SINIF ÖĞRETMENİ ADAYLARININ ÇOKLU TEMSİLERİ KULLANIM SÜREÇLERİ

THE REPRESENTATIONS OF PRE-SERVICE ELEMENTARY TEACHERS USED IN SOLVING MATHEMATICAL PROBLEMS

Ayten Pınar BAL
Çukurova Üniversitesi
apinar@cu.edu.tr

ÖZET: Bu çalışma, sınıf öğretmeni adaylarının verilen farklı temsil biçimlerini grafiksel temsil biçimlerine dönüştürebilme becerilerini ortaya çıkarmaya yönelik tarama modelinde betimsel bir araştırmadır. Araştırmanın çalışma grubunu 2012-2013 eğitim öğretim yılında sınıf öğretmenliği bölümü birinci sınıfına devam eden toplam 119 öğrenci oluşturmaktadır. Veri toplama aracı olarak ilgili literatürden yararlanılarak “Temsil Dönüşüm Testi (TDT)” hazırlanmıştır. Temsil Dönüşüm Testi (TDT) dört bölümden ve on üç sorudan oluşmaktadır. Buna göre ilk bölümde tablo biçiminde üç soru, ikinci bölümde cebirsel denklem biçiminde üç soru, üçüncü bölümünde sözel ifade biçiminde üç soru, son bölümünde ise şekil biçiminde dört soru yer almaktadır. Araştırmanın analizinde betimsel istatistik teknikleri uygulanmıştır. Araştırmanın sonucunda cebirsel denklem ve tablodan grafiğe geçiş, adayların en başarılı oldukları alan olarak ortaya çıkarken; şekil biçiminde verilen temsillerin grafiğe dönüştürülmesinde ise öğretmen adaylarının büyük sorun yaşadıkları bulgusuna ulaşılmıştır. Bu sonuçlardan yola çıkarak, yaşanan sorunların neden kaynaklandığının belirlenmesine yönelik nitel bir araştırma yapılması, lisans derslerinde özellikle grafiksel temsillerle ilgili sorunların giderilmesine yönelik farklı yöntem ve tekniklerin geliştirilmesi önerilebilir.

Anahtar sözcükler: öğretmen adayı, çoklu temsiller, temsiller arası geçiş, İlköğretim matematik öğretim programı

ABSTRACT: The research is a qualitative study and designed according to survey model in order to figure out primary school teachers' transformation skills about the different representation forms into the graphical representations. The population of this study was 119 pre-service teachers studying in Primary School Education Department in 2012-2013 academic falls. A literature supported “Representation Transformation Test” (RTT) test was formed by the researcher as a data collection tool. The achievement test has fourth parts and thirteen questions. Hereunder, in the first part there are three questions in table form, in the second part there are three questions in algebraic equation form, in the third part there are three questions in verbal expression form, and in the last part there are four questions in modal form. The study was analyzed through descriptive statistics. According to results while passing from algebraic equation and table form to graphics is the most achieved area, the prospective teachers had some difficulties in terms of transforming modal forms into graphical representations. In line with these results, carrying out a qualitative research related to these challenges and developing different method and techniques in undergraduate courses for eliminating difficulties about graphical representations can be suggested.

Key words: pre-service teachers, multiple representations, visualization and graphical representations, primary school mathematics curriculum,

GİRİŞ

Matematiksel bir kavramın oluşturulması, biçimlendirilmesi sürecinde temsiller büyük önem taşımaktadır (Cai, 2005). Öğretim süreçlerinde, uygun matematiksel temsillerin seçilebilmesi, transfer edilebilmesi ve seçilen temsillerin sosyal ve fiziksel olaylar çerçevesinde öğrenciler tarafından uygulanıp yorumlanabilmesi ve bunlar arasında ilişkilerin kullanılması büyük önem taşımaktadır. Temsiller matematiğin öğrenilmesi ve öğretilmesinde önemli yapılardan biridir. (Cobb, Yackel, & Wood, 1992; Goldin, 1998; Janvier, 1987; Cai, 2005). Stylianou (2010) da öğrencilerin matematik öğretiminde yer alan kavramlar ve problem çözümlerinde temsillerin kullanımları ve bunlar arasındaki geçişlerde etkin olmaları gerektiğini belirtmektedir. Temsiller, öğrencilerin matematiksel anlamalarını desteklemeleri için birer araç (Hjalmarson, 2007) olup onların düşüncelerini organize etmelerine yardımcı olur (Cathcart, Pothier, Vance & Bezuk, 2006). Öte yandan, Amerikan Ulusal Matematik Öğretmenleri Konseyi'nin (NCTM (National Council of Teachers of Mathematics, 2000) öğretim standartları arasında yer alan temsil kavramı diyagram, manipulatif, grafik, tablo ve sembollerin kullanımına vurgu yapar.

İlgili literatürde genellikle ilköğretim düzeyine odaklanan çalışmalar öğrencilerin çoklu temsil dönüşümleri konusunda genelde yetersiz bilgilere sahip olduklarını göstermektedir (Cai, 2004; Gagatsis & Elia, 2004; Neria & Amit, 2004; Sert, 2007; Kılıç, 2009; Ahmad, Tarmizi, & Nawawi (2010). Yine, lisans düzeyinde göze çarpan sınırlı sayıda araştırmalar da benzer sonuçlara işaret etmektedir (Çelik & Sağlam-Aslan, 2012; Delice & Sevimli, 2010; Even, 1998; İpek & Okumuş, 2012). Bu bağlamda, Gagatsis ve Elia (2004) ilköğretim öğrencilerinin temsil ve temsiller arası geçiş becerileri ile ilgili derinlemesine bir araştırma yürütmüşlerdir. Araştırmanın sonucunda, öğrencilerin protatip biçiminde verilen grafiksel formu tablo haline kolayca dönüştürebildikleri; ancak, sembolik ve sözel temsiller arası dönüşümlerde ise oldukça zorlandıkları sonucuna ulaşılmıştır. Neria & Amit (2004) de öğrencilerinin problem çözmeye örüntüleri ve doğrulama sürecinde tercih ettikleri temsil modelleri ve bunun akademik başarıya olan etkisini inceledikleri araştırmalarında, öğrencilerin büyük çoğunluğunun sözel temsilleri tercih ettiklerini; ayrıca, cebirsel temsilleri kullanan öğrencilerin başarı düzeylerinin diğer temsilleri kullanan öğrencilere göre daha yüksek olduğunu ortaya çıkarmışlardır. Cai (2004) ise Çinli ve Amerikalı ilköğretim öğrencilerinin kullandıkları stratejileri ve temsilleri incelenmiştir. Araştırmada her iki grupta bulunan öğrencilerin problem çözme sırasında görsel temsillerden yararlandıkları ortaya çıkmıştır. Öte yandan, Even (1998) çalışmasında 152 matematik öğretmen adayının fonksiyonlar konusundaki bilgisini ve bir temsilden diğerine nasıl geçiş yaptığını incelemiştir. Araştırmanın sonucunda Even, öğretmen adaylarının çoklu gösterimler arasında esnek ilişkilendirmeler yapmaları gereken durumlarda çok başarılı olmadıkları sonucuna ulaşmıştır. Benzer şekilde Delice ve Sevimli (2010) de araştırmalarında öğretmen adaylarının temsil bilgileri ve farklı temsil kullanma becerileri yönünden yeterli bilgiye sahip olmadıklarını belirlemişlerdir. Öte yandan, İpek ve Okumuş (2012) ilköğretim matematik öğretmen adaylarının problem çözme süreçlerinde kullandıkları temsil türlerini ve bu temsillerle ilgili yaşadıkları sorunları araştırdıkları çalışmalarının sonucunda öğretmen adaylarının özellikle sözel temsilleri daha yoğun kullandıkları sonucuna ulaşmışlardır. Başka bir araştırmada ise Çelik ve Sağlam-Arslan (2012) sınıf öğretmeni adaylarının sözel, tablo, şekilsel gösterimler ve grafikler arası geçiş yapabilme becerilerini incelemişlerdir. Çalışma sonucunda, sözel ifadelerden grafiğe geçiş, adayların en başarılı oldukları alan olarak ortaya çıkarken şekilsel gösterimden grafiğe geçiş ise en az başarılı oldukları alan olarak dikkat çekmektedir.

Yukarıdaki bilgiler ışığında, çoklu temsil dönüşümleri konusunda özellikle öğretmen adayları ile yürütülen çalışmaların sınırlı sayıda olduğu görülmektedir (Çelik & Sağlam-Aslan, 2012; Delice & Sevimli, 2010; Even, 1998; İpek & Okumuş, 2012). Bu düşünceden yola çıkarak bu çalışma ile sınıf öğretmeni adaylarının tablo, cebir, sözel, şekilsel gösterimler ve grafikler arasında geçiş yapabilme becerileri ortaya çıkarılarak alandaki bir eksiklik giderilmeye çalışılmıştır. Bu genel amaç doğrultusunda araştırmanın alt amaçları şöyledir:

- 1) Öğretmen adayları tablo biçiminde verilen soruların ne kadarını grafiksel temsil biçiminde ifade etmektedir?
- 2) Öğretmen adayları cebirsel temsil biçiminde verilen soruların ne kadarını grafiksel temsil biçiminde ifade etmektedir?
- 3) Öğretmen adayları sözel temsil biçiminde verilen soruların ne kadarını grafiksel temsil biçiminde ifade etmektedir?
- 4) Öğretmen adayları şekilsel biçiminde verilen soruların ne kadarını grafiksel temsil biçiminde ifade etmektedir?

YÖNTEM

Bu çalışma sınıf öğretmeni adaylarının verilen farklı temsil biçimlerini grafiksel temsil biçimlerine dönüştürebilme becerilerini ortaya çıkarmaya yönelik tarama modelinde betimsel bir araştırmadır.

Çalışma Grubu

Araştırma 2012-2013 bahar döneminde sınıf öğretmenliği bölümünde birinci sınıfa devam eden 119 (kız:81; erkek: 31) öğrenciyle yürütülmüştür. Çalışma grubu belirlenirken amaçlı örnekleme yöntemlerinden ölçüt örnekleme kullanılmıştır. Buna göre çalışma grubu sınıf öğretmenliği lisans programı kapsamında yer alan Temel Matematik I ve Temel Matematik II dersini alan öğrenciler oluşturmaktadır. Temel matematik I ve II derslerinin içeriğinde matematiksel kavramlar, grafik çizimleri, veri toplama, verilerin özetlenmesi, grafiklerle gösterme, oran-orantı konuları yer almaktadır.

Veri Toplama Aracı

Veri toplama aracı olarak ilgili literatürden (Çelik ve Sağlam-Aslan, 2012; Even, 1998; Lesh, Behr ve Post, 1987, Sert, 2007) yararlanılarak "Temsil Dönüşüm Testi (TDT)" hazırlanmıştır. Temsil Dönüşüm Testi (TDT) dört bölümden ve on üç sorudan oluşmaktadır. Buna göre ilk bölümde tablo biçiminde üç soru, ikinci bölümde cebirsel denklem biçiminde üç soru, üçüncü bölümünde sözel ifade biçiminde üç soru, son bölümünde ise şekil biçiminde dört soru yer almaktadır. TDT'nin geçerliğini sınamak üzere, matematik eğitimi alanında iki uzman tarafından testin ölçmeyi hedeflediği davranışlar yönüyle, kapsam ve görünüş geçerliğine sahip olduğu belirlenmiştir. Daha sonra temel matematik derslerini başarıyla tamamlayan ve ikinci sınıfta öğrenim gören dört öğrenciye pilot uygulama yapılmıştır. Uygulama aşamasında öğrencilere araştırmanın amacı hakkında bilgi

verilmiş ve ölçme aracında anlamadıkları her hangi bir soru olup olmadığı konusunda dönüt alınmıştır. Uygulama sürecinde ise testin anlaşılması ve süre açısından herhangi bir zorlukla karşılaşılmamıştır.

Veri Analizi

Verilerin analizi aşamasında “Temsil Dönüşüm Testi (TDT)” ölçme aracından yer alan soruların grafiksel biçime dönüşümleri incelenmiş ve temsiller arasındaki geçişler doğru ise “1”, yanlış ise “0” olarak kodlanmıştır. Temsil Dönüşüm Testi’nin güvenilirliğini belirlemek için bu testi cevaplayan öğrencilerden rastgele seçilen 20 öğrencinin cevap kâğıtları seçilmiş matematik eğitimi alanında bir uzman tarafından da analiz edilmiş ve Miles ve Huberman (1994) tarafından önerilen $Görüş\ birliği / (Görüş\ birliği + Görüş\ ayrılığı) \times 100$ formülü kullanılarak yapılan hesaplama sonucu kodlayıcılar arasındaki uyuma oranı .93 olarak hesaplanmıştır. Daha sonra kodlayıcılar ve araştırmacı arasında yapılan görüşmede farklılık görülen ifadelerde fikir birliğine varılmıştır. Yapılan bu sınıflandırmalardan elde edilen bulguların sunulmasında betimsel istatistik tekniklerinden yararlanılmıştır.

BULGULAR

Öğretmen adaylarının verilen farklı temsilleri grafiğe dönüştürebilme becerilerine yönelik yapılan analiz sonucunda elde edilen bulgular araştırmanın alt amaçlarıyla paralel olarak sunulmuştur. Öncelikle tablo biçiminde verilen sorunun grafiğe dönüştürülmesine ilişkin elde edilen veriler Tablo 1’de yer almaktadır.

Tablo 1. Tablo Biçiminde Verilen Soruların Grafiksel Temsil Biçimine Dönüştürülmesine İlişkin Frekans ve Yüzde Dağılımı

Soru No	Grafiksel Temsil					
	Doğru		Yanlış		Boş	
	f	%	f	%	f	%
S1	98	82.4	20	16.8	1	.8
S2	81	68.1	38	31.9	-	-
S3	79	66.4	40	33.6	-	-

Tablo 1 incelendiğinde araştırmaya katılan öğretmen adaylarının en az %66’sı tablo biçiminde verilen soruları grafiksel biçime dönüştürebildikleri görülmektedir. Bunun yanında birinci soru birinci dereceden bir bilinmeyenli denklemle ilgili olup doğrusal bir grafiği temsil ettiğinden dolayı araştırmaya katılan öğretmen adaylarının büyük çoğunluğu (%84) grafiği doğru olarak oluşturmuştur. Ancak ikinci ve üçüncü sorular doğrusal olmayan grafik çizimleriyle ilgili olduğundan araştırmaya katılan öğretmen adaylarının yaklaşık %30’nun grafiği yanlış oluşturduğu Tablo 1’de açıkça görülmektedir. Örneğin, 3. soruda Ö₃₁ kodlu öğretmen adayının oluşturduğu grafik Şekil 1’de yer almaktadır.

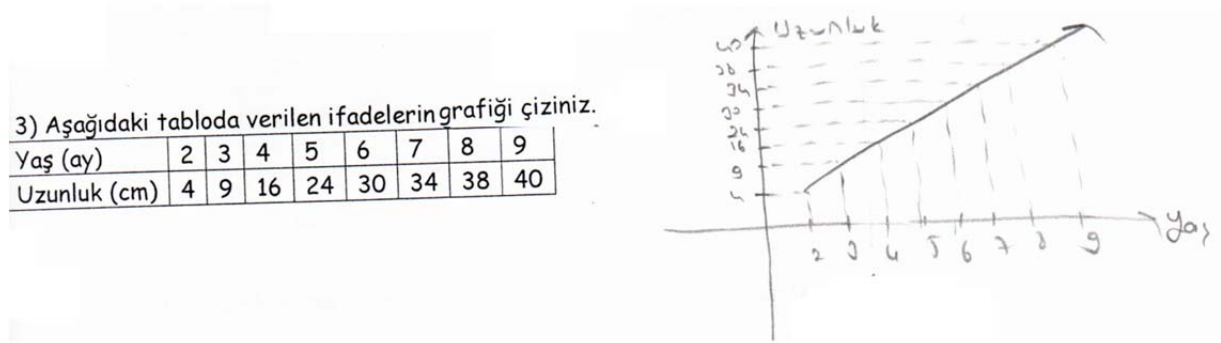

Şekil 1. Ö₃₁ Kodlu Adayın 3. Soruda Oluşturduğu Grafiksel Temsil

Ö₃₁ kodlu öğretmen adayının 3. soruda oluşturduğu grafiksel temsilin yanlış olduğu görülmektedir. Şekil 1’de incelendiğinde öğretmen adayının soruyu doğrusal bir fonksiyon olarak düşündüğü ve buna uygun bir grafik çizdiği anlaşılmaktadır.

Araştırmanın ikinci alt amacı olarak cebirsel denklem olarak verilen soruların grafiksel temsil biçimine dönüştürülmesiyle ilgilidir. Buna ilişkin elde edilen bulgular Tablo 2’de yer almaktadır.

Tablo 2. Cebirsel Denklem Biçiminde Verilen Soruların Grafiksel Temsil Biçimine Dönüştürülmesine İlişkin Frekans ve Yüzde Dağılımı

Soru No	Grafiksel Temsil					
	Doğru		Yanlış		Boş	
	f	%	f	%	f	%
S4	73	61.3	46	38.7	-	-
S5	84	70.6	37	29.4	-	-

Tablo 2 incelendiğinde öğretmen adayların büyük bir çoğunluğunun cebirsel formda verilen soruları grafiksel biçime dönüştürebildikleri sonucuna görülmektedir. Bu bağlamda, örneğin, 4. soruda Ö₅₉ kodlu öğretmen adayının oluşturduğu grafik Şekil 2’de yer almaktadır.

$y = 30 - x$ denklemi veriliyor. Bu ilişkiyi gösteren grafiği çiziniz.

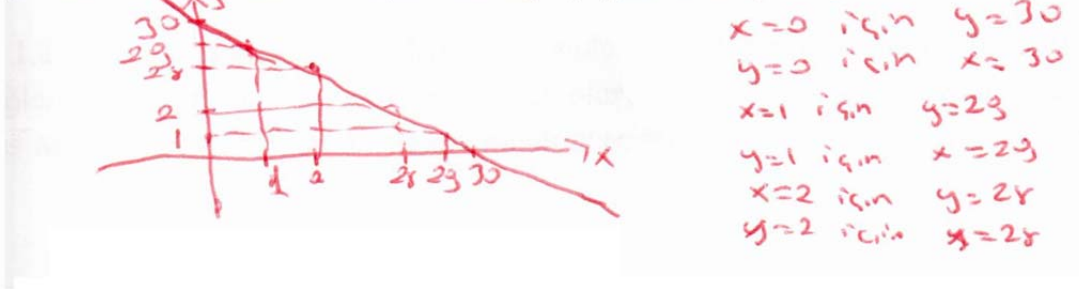

Şekil 2. Ö₅₉ Kodlu Adayın 4.Soruda Oluşturduğu Grafiksel Temsil

Şekil 2 incelendiğinde Ö₅₉ kodlu öğretmen adayının 4. soruda kendi oluşturduğu grafiksel temsili kullandığı görülmektedir.

Araştırmanın üçüncü alt amacı sözel olarak verilen soruların grafiksel temsil biçiminde dönüştürülmesiyle ilgilidir. Buna ilişkin elde edilen bulgular Tablo 3’te yer almaktadır.

Tablo 3. Sözel Temsil Biçiminde Verilen Soruların Grafiksel Temsil Biçimine Dönüştürülmesine İlişkin Frekans ve Yüzde Dağılımı

Soru No	Grafiksel Temsil					
	Doğru		Yanlış		Boş	
	f	%	f	%	f	%
S7	43	36.1	71	59.7	5	4.2
S8	49	41.2	62	52.1	8	6.7
S9	41	34.5	74	62.2	4	3.4

Tablo 3 incelendiğinde yedinci, sekizinci ve dokuzuncu sorularla ilgili olarak araştırmaya katılan öğretmen adaylarının yaklaşık üçte birinin (%36, %41 ve %35) doğru cevaplar verdikleri görülmektedir. Örneğin, 9. soruyla ilgili olarak da Ö₁₃ kodlu öğretmen adayının oluşturduğu grafik Şekil 3’te yer almaktadır.

9) İrem’in yeni abone olduğu bir telefon hattının tarifesinde aylık sabit ücret 15 Lira ve dakika ücreti 1 liradır. İrem’i yeni tarifesini hakkında bilgilendirmek için aylık ücretle konuşma süresi (dakika) arasındaki bağıntıyı belirleyiniz. Grafiğini çiziniz.

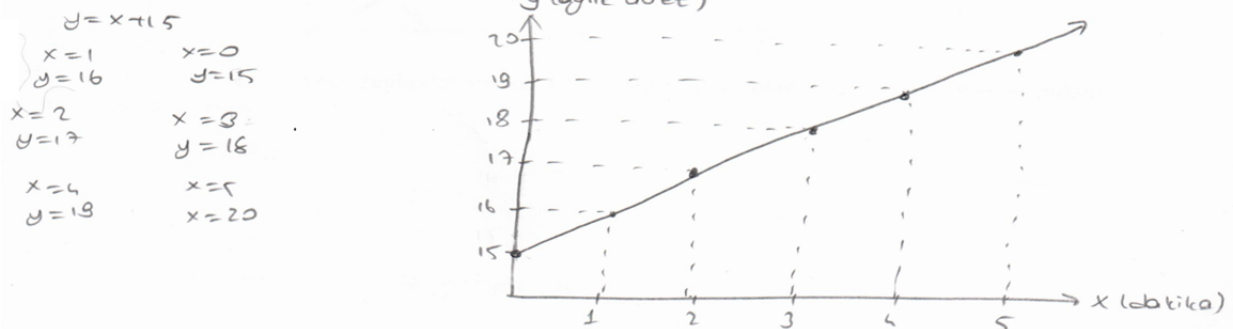

Şekil 3. Ö₁₃ Kodlu Adayın 9.Soruda Oluşturduğu Grafiksel Temsil

Şekil 3’te görüldüğü gibi, Ö₁₃ kodlu öğretmen adayının verilen soruya uygun birinci dereceden artan bir grafik çizdiği görülmektedir. Ancak aynı soru kapsamında Ö₁ kodlu öğretmen adayının oluşturduğu yanlış grafik Şekil 4’te yer almaktadır.

9) İrem'in yeni abone olduğu bir telefon hattının tarifesinde aylık sabit ücret 15 Lira ve dakika ücreti 1 liradır. İrem'i yeni tarifesi hakkında bilgilendirmek için aylık ücretle konuşma süresi (dakika) arasındaki bağıntıyı belirleyiniz. Grafiğini çiziniz.

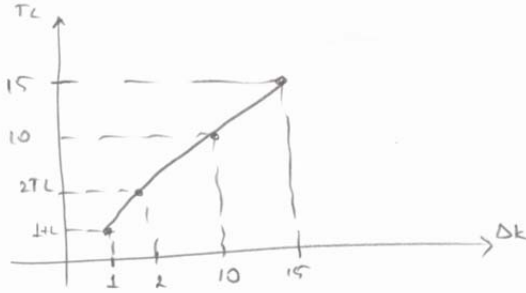

Şekil 4. Ö₁ Kodlu Adayın 9. Soruda Oluşturduğu Grafikselsel Temsil

Şekil 4 incelendiğinde Ö₁ kodlu öğretmen adayının 9.soruyla ilgili olarak uygun bir grafik çizemediği artan bir fonksiyon olduğunu fark ettiği ama buna rağmen sabit ücreti dikkate almadan grafiği çizdiği görülmektedir.

Araştırmanın dördüncü ve son alt amacı şekil olarak verilen soruların grafikselsel temsil biçimine dönüştürülmesiyle ilgilidir. Buna ilişkin elde edilen bulgular Tablo 4'te yer almaktadır.

Tablo 4. Şekilsel Verilen Soruların Grafikselsel Temsil Biçimine Dönüştürülmesine İlişkin Frekans ve Yüzde Dağılımı

Soru No	Grafikselsel Temsil					
	Doğru		Yanlış		Boş	
	f	%	f	%	f	%
S10	22	18.5	93	78.2	4	3.4
S11	23	19.3	92	77.3	4	3.4
S12	49	41.2	65	54.6	5	4.2
S13	15	12.6	99	83.3	5	4.2

Tablo 4 incelendiğinde şekille ilgili olarak verilen sorulardan onuncu ve on birinci soruların %19'u, on ikinci sorunun %41'i ve on üçüncü sorunun da%13'ü doğru olarak cevaplandırılmıştır. Bu kapsamda, 12. soruyla ilgili olarak da Ö₂₈ kodlu öğretmen adayının oluşturduğu yanlış grafik Şekil 5'te yer almaktadır.



12) Yukarıda şekli verilen tank suyla doldurulacaktır. Tanka doldurulan suyun yüzey alanı yükseklik grafiğini oluşturunuz.



yükseklik arttıkça su miktarı doğru orantıyla aynı miktarda artar. yüzey alanı değişime düşünde su miktarı aynıdır.

Şekil 5. Ö₂₈ Kodlu Adayın 12. Soruda Oluşturduğu Grafikselsel Temsil

Şekil 5 incelendiğinde Ö₂₈ kodlu adayın 12.soruyla ilgili yükseklik ile yüzey alanı arasındaki çizdiği yanlış bir grafik çizdiği görülmektedir.

SONUÇ ve ÖNERİLER

Bu çalışma ile sınıf öğretmeni adaylarının verilen farklı temsil biçimlerini grafikselsel temsil biçimlerine dönüştürebilme becerileri irdelenmeye çalışılmıştır. Araştırmanın sonucunda cebirsel denklem ve tablodan grafiğe geçiş, adayların en başarılı oldukları alan olarak ortaya çıkarken; şekil biçiminde verilen temsillerin grafiğe dönüştürülmesinde ise öğretmen adaylarının büyük sorun yaşadıkları bulgusuna ulaşılmıştır. Bu sonuçlardan yola çıkarak, yaşanan sorunların neden kaynaklandığının belirlenmesine yönelik nitel bir araştırma

yapılması, lisans derslerinde özellikle grafiksel temsillerle ilgili sorunların giderilmesine yönelik farklı yöntem ve tekniklerin geliştirilmesi önerilebilir.

KAYNAKLAR

- Ahmad, A., Tarmizi, R. A. & Nawawi, M. (2010). Visual Representations in Mathematical Word Problem Solving Among Form Four Students in Malacca. *Procedia - Social and Behavioral Sciences*, 8, 356-361.
- Cai, J. (2004). Why do U.S. and Chinese students think differently in mathematical problem solving? Exploring the impact of early algebra learning and teachers' beliefs. *Journal of Mathematical Behavior*, 23, 135-167.
- Cai, J. (2005). U.S. and Chinese teachers' constructing, knowing, and evaluating representations to teach mathematics. *Mathematical Thinking and Learning*, 7(2), 135-169.
- Cathcart, W. G., Pothier, Y. M., Vance, J. H. & Bezuk, N. S. (2006). *Learning mathematics in Elementary and Middle Schools* (4th Ed.). N.J.: Merrill/Prentice Hall.
- Cobb, P., Yackel, E., & Wood, T. (1992). A constructivist alternative to the representational view of mind in mathematics education. *Journal for Research in Mathematics Education*, 23, 2-33.
- Çelik, D., & Sağlam-Arslan, A. (2012). Öğretmen adaylarının çoklu gösterimleri kullanma becerilerinin analizi. *İlköğretim Online*, 11(1), 239-250.
- Delice, A. & Sevimli, E. (2010). Öğretmen adaylarının çoklu temsil kullanma becerilerinin problem çözme başarıları yönüyle incelenmesi: Belirli integral örneği. *Educational Sciences: Theory & Practice*, 10 (1), 111-149.
- Even, R. (1998). Factors involved in linking representations of functions. *Journal of Mathematical Behavior*, 17(1), 105-121.
- Gagatsis; A. & Elia, I. (2004). The effects of different modes of representation on mathematical problem solving. *Proceedings of the 28th Conference of the International Group for the Psychology of Mathematics Education*, 2, 447-454
- Goldin, G. A. (1998). Representational systems, learning, and problem solving in mathematics. *Journal of Mathematical Behavior*, 17 (2), 137-165.
- İpek, A. S. & Okumuş, S. (2012). İlköğretim matematik öğretmen adaylarının matematiksel problem çözmeye kullandıkları temsiller. *Gaziantep Üniversitesi Sosyal Bilimler Dergisi*, 11(3), 681 -700.
- Janvier, C. (1987). Representation system and mathematics. In C. Janvier (Ed.), *Problems of Representations in the Learning and Teaching of Mathematics*, (p. 19-27). New Jersey: Lawrence Erlbaum Associates.
- Kılıç, Ç. (2009). *İlköğretim beşinci sınıf öğrencilerinin problem çözümlerinde kullandıkları temsiller*. Yayınlanmamış doktora tezi, Anadolu Üniversitesi, Eskişehir.
- Lesh, R., Post, T., & Behr, M. (1987). Representations and translations among representations in mathematics learning and problem solving. In C. Janvier (Ed.), *Problems of representation in the teaching and learning of mathematics* (pp. 33-40). New Jersey: Lawrence Erlbaum Associates.
- Miles, M. B., & Huberman A. M. (1994). *An expanded sourcebook qualitative data analysis* (2nd Ed.). California: Sage Publications.
- NCTM, (2000). *Principles and standards for school mathematics*. Reston, VA: National Council of Teachers of Mathematics.
- Neria, D. & Amit, M. (2004). Students preference of non-algebraic representations in mathematical communication. *Proceedings of the 28th Conference of the International Group for the Psychology of Mathematics Education*. 3, 409-416.
- Sert, Ö. (2007). Eighth grade students' skills in translating among different representations of algebraic concepts. Unpublished Master Thesis, Middle East Technical University, Ankara.
- Stylianou, D. A. (2010). Teachers' conceptions of representation in middle school mathematics. *J Math Teacher Educ*, 13, 325-343. DOI 10.1007/s10857-010-9143.

MÜHENDİSLİK ÖĞRENCİLERİNİN İRRASYONEL SAYI BİLGİLERİ

Necdet GÜNER

Bu çalışma, Pamukkale Üniversitesi mühendislik fakültesinde, ayrı matematiksel yapılar dersini alan bilgisayar mühendisliği birinci sınıf öğrencileri üzerinde yapılmıştır. Öğrencilere verilen ara sınavlarda ve dönem sonu sınavında ayrı matematiksel yapılar dersi ile ilgili bazı sorularda, öğrencilerin irrasyonel sayı bilgilerinden de yararlanmalarını gerekecek sorular sorulmuştur. Bunun dışında, bir kısa sınavda öğrencilerin irrasyonel sayılar hakkındaki bilgilerinin belirlenmesi amacı ile sorular sorulmuştur.

İrrasyonel sayılarla ilgili sınav sayfaları araştırmacı tarafından notlandırılmadan ikişer fotokopisi alınmıştır. Araştırmacı bir matematik alan uzmanı ile birlikte notlandırma metodu üzerinde konuşmuş ve her iki uzman tüm soruları bağımsız olarak notlandırmıştır. Notlandırma sonrası sonuçlar karşılaştırılmış ve %20 den büyük bir fark olan sorular beraberce değerlendirilerek ortak bir görüşe varılmıştır.

Yapılan araştırmanın sonuçlarına göre, öğrencilerin büyük çoğunluğunun irrasyonel sayıların bir küme olarak sayılar sistemindeki yerini bilmedikleri görülmüştür. Ayrıca, irrasyonel sayıların toplama ve çarpma işlemlerine göre kapalı olup olmadıklarının açık olarak bilinmediği, belirlenen bir aralıkta irrasyonel sayı örneği verilmesi istenen bazı öğrencilerin ise rasyonel veya karmaşık sayıları örnek verdikleri tespit edilmiştir. Bunun dışında, öğrencilerin büyük çoğunluğunun irrasyonel sayıların sonsuz basamaklı sayılar oldukları hakkında bilgi sahibi olmadıkları da görülmüştür.

Ülkemizde okutulmakta olan lise matematik ders kitapları incelendiğinde, irrasyonel sayılarla ilgili bölümün soruları ile birlikte beş sayfadan az olduğu görülmektedir. Bu durum öğrencilerin irrasyonel sayılar hakkında yeterince bilgi sahibi olmasına ve irrasyonel sayılarla ilgili özellikleri içselleştirmeleri için yeterli olmadığı düşünülmektedir.

Anahtar Kelimeler: İrrasyonel sayılar, mühendislik öğrencileri

oooooooooooooooo

MÜHENDİSLİK ÖĞRENCİLERİNİN İRRASYONEL SAYI BİLGİLERİ

Necdet GÜNER

Bu çalışma, Pamukkale Üniversitesi mühendislik fakültesinde, ayrı matematiksel yapılar dersini alan bilgisayar mühendisliği birinci sınıf öğrencileri üzerinde yapılmıştır. Öğrencilere verilen ara sınavlarda ve dönem sonu sınavında ayrı matematiksel yapılar dersi ile ilgili bazı sorularda, öğrencilerin irrasyonel sayı bilgilerinden de yararlanmalarını gerekecek sorular sorulmuştur. Bunun dışında, bir kısa sınavda öğrencilerin irrasyonel sayılar hakkındaki bilgilerinin belirlenmesi amacı ile sorular sorulmuştur.

İrrasyonel sayılarla ilgili sınav sayfaları araştırmacı tarafından notlandırılmadan ikişer fotokopisi alınmıştır. Araştırmacı bir matematik alan uzmanı ile birlikte notlandırma metodu üzerinde konuşmuş ve her iki uzman tüm soruları bağımsız olarak notlandırmıştır. Notlandırma sonrası sonuçlar karşılaştırılmış ve %20 den büyük bir fark olan sorular beraberce değerlendirilerek ortak bir görüşe varılmıştır.

Yapılan araştırmanın sonuçlarına göre, öğrencilerin büyük çoğunluğunun irrasyonel sayıların bir küme olarak sayılar sistemindeki yerini bilmedikleri görülmüştür. Ayrıca, irrasyonel sayıların toplama ve çarpma işlemlerine göre kapalı olup olmadıklarının açık olarak bilinmediği, belirlenen bir aralıkta irrasyonel sayı örneği verilmesi istenen bazı öğrencilerin ise rasyonel veya karmaşık sayıları örnek verdikleri tespit edilmiştir. Bunun dışında, öğrencilerin büyük çoğunluğunun irrasyonel sayıların sonsuz basamaklı sayılar oldukları hakkında bilgi sahibi olmadıkları da görülmüştür.

Ülkemizde okutulmakta olan lise matematik ders kitapları incelendiğinde, irrasyonel sayılarla ilgili bölümün soruları ile birlikte beş sayfadan az olduğu görülmektedir. Bu durum öğrencilerin irrasyonel sayılar hakkında yeterince bilgi sahibi olmasına ve irrasyonel sayılarla ilgili özellikleri içselleştirmeleri için yeterli olmadığı düşünülmektedir.

Keywords: Irrational numbers, the engineering students

ORTAOKUL ÖĞRENCİLERİNİN MATEMATİK TERİMLERİNİ SÖZEL VE MATEMATİKSEL TEMSİL BECERİLERİ

SECONDARY SCHOOL STUDENTS' SKILLS IN VERBAL AND MATHEMATICAL REPRESENTATION OF THE MATHEMATICAL TERMS

Nuray ÇALIŞKAN DEDEOĞLU

Sakarya Üniversitesi Eğitim Fakültesi İlköğretim Bölümü

ndedeoglu@sakarya.edu.tr

Zehra GÖKÇE

M.E.B. Kabakulak Anadolu Kalkınma Vakfı Ortaokulu

zehra.gokce1@ogr.sakarya.edu.tr

ÖZET: Matematiğin semboller ve şekillerden oluşan soyut yapısından dolayı terimlerin, kavramı temsil gücü her zaman yeterli olmamaktadır. Kavramların sözel ve matematiksel temsillerinin birbirine çağrışım yapabilmeleri öğretimde kolaylık ve kalıcılık açısından önemlidir. Matematik terminolojisi ile öğrenme arasındaki ilişkiyi ele alan uluslararası çalışmalarda, terimlere anlam yüklemeyi etkileyen çeşitli faktörler belirlenmiş ve kavram öğretiminde terimler üzerinden özel öğretim yöntemlerine ihtiyaç olduğu vurgulanmıştır. Çalışmamızda, öncelikle matematik terimlerini anlamayı etkileyen dilsel faktörler tespit edilerek, bu faktörler bazında ortaokul 8. sınıf öğrencilerinin terimlere yüklediği anlam ve matematiksel örnek verme becerilerinin ne düzeyde olduğunu belirlemek amaçlanmaktadır. Bu amaçla geliştirilen matematik terimleri ölçeği öğrenciler tarafından doldurulduktan sonra elde edilen veriler içerik analizi tekniği ile nitel olarak incelenmiştir. Bulgular, öğrencilerin matematik terimlerini sözel açıklama becerilerinin, matematiksel temsil becerilerine göre oldukça zayıf olduğunu ve anlam yüklemeye olumsuz yönde etki eden en önemli faktörlerin yabancı kökenli terimler ile matematiksel anlamı ile günlük dildeki anlamı farklı olan terimler olduğunu ortaya koymaktadır.

Anahtar kelimeler: matematik terimleri, ortaokul matematik öğretimi, matematik öğretiminde temsiller

ABSTRACT: As mathematics consists of abstract symbols and shapes, the terms are inefficient to represent the concept and mathematical representations. From the point of view of easiness and sustainability of the teaching, it is important that verbal and mathematical representations of concepts associate with each other. International studies that treat the relationship between mathematical terminology and learning have identified various factors attributing terminology its meaning and in the concept teaching of terms, and have emphasised the need of special teaching techniques. In our study, first, the linguistic factors affecting the understanding of mathematical terms in our language have been identified and on the view of these, it is aimed to find out the level of skills of 8th grade students of secondary school in giving mathematical examples and in attributing meanings to the terms. After the mathematical terms scale developed for this aim has been filled in by the students, the results have been evaluated in a qualified way by the content analysis technique. Findings reveal that students are weak in verbal explanation skills of mathematical terms when compared with their mathematical representation skills. Foreign-originated terms and the terms having different meaning in daily language and mathematical usage, are among the most important factors affecting negatively in attributing meanings to mathematical terms.

Key words: mathematical terms, mathematic teaching in the secondary school, representations in teaching mathematics.

GİRİŞ

Matematik diğer bilimlerde olduğu gibi kendine özgü terminolojisi olan bir bilimdir. Matematiksel bir terim yalnızca kavrama verilen bir isimdir ve bu sayede kavramı sözel olarak temsil eder. Matematiğin semboller ve şekillerden oluşan soyut yapısından dolayı terimlerin, kavramı temsil gücü her zaman yeterli olmamaktadır ve matematiksel temsiller kaçınılmazdır. Bir konuya ait farklı temsillerin oluşturulması konunun özümsemesi açısından önemlidir. Tanım, resim, grafik, şekil, sembol, modelleme ve benzeri farklı temsiller kavramı zenginleştirdiği gibi öğrenme stillerindeki farklılığı da dikkate almayı sağlar. Çoklu temsiller sayesinde öğrenci

zihninde kavramların gerçek anlamlarına yakın kavram görüntüleri oluşmaktadır (Ainsworth, 2006; Akkoç, 2006; Tall ve Vinner, 1981). Kavramların farklı şekilde temsil edilmesi ve bu temsiller arasında ilişki kurularak matematiksel düşüncenin ifade edilmesi, bu süreçte matematiksel terminoloji ve dilin doğru kullanılabilmesi ortaokul matematik öğretiminin genel amaçları arasında yer almaktadır (Millî Eğitim Bakanlığı [MEB], 2013). Böylece kavramların tanımları ve kuralların öğretilmesi esnasında farklı temsiller verilerek öğrencilerin kavramlar arasındaki ilişkiyi kendilerinin kurmaları hedeflenmektedir. Ortaokul Matematik Dersi Öğretim Programı'nda ayrıca, matematiksel süreç becerilerinden iletişim ve ilişkilendirme becerilerinin gelişiminde matematik dilinin etkili kullanımı, günlük dil ve diğer alanlarla ilişkilendirilmesi, çoklu temsiller üzerine vurgu yapılmaktadır (MEB, 2013).

Kavramların sözel ve matematiksel temsillerinin birbirine çağrışım yapabilmeleri öğretimde kolaylık ve kalıcılık açısından önemlidir. Öğretimde en önemli başlangıç, çocukların önceden bildikleriyle, yeni terim ve ifadeler arasında bağlantı kurmaktır (Rubenstein ve Thompson, 2002). Adams'a (2003) göre sayı, sembol ve terimleri okumak matematiği başarmak için bilinmesi gereken birçok şeyin gizli anahtarıdır. Öğrencilerin matematik problemlerini çözme zorluğu ve doğru sonuca ulaşamamalarının altında çoğunlukla terimleri anlama güçlüğü yatmaktadır (Larson, 2007). Matematik terminolojisi ile öğrenme arasındaki ilişkiyi ele alan uluslararası çalışmalarda, terimlere anlam yüklemeyi etkileyen çeşitli faktörler belirlenmiş ve kavram öğretiminde terimler üzerinden özel öğretim yöntemlerine ihtiyaç olduğu vurgulanmıştır (Adams, 2003; Kovarik, 2010; Larson, 2007; Rubenstein ve Thompson, 2002).

Uluslararası çalışmalara paralel olarak, çalışmamızda, öncelikle matematik terimlerini olumlu veya olumsuz yönde anlamayı etkileyen dilsel faktörler tespit edilmiş; bu faktörler bazında, ortaokul 8. sınıf öğrencilerinin terimlere yüklediği anlam ve matematiksel örnek verme becerilerini ortaya koymak amaçlanmıştır.

YÖNTEM

Araştırmada nitel araştırma yöntemlerinden fenomenoloji yöntemi kullanılmıştır. Fenomenoloji yöntemi, bireylerin kişisel tecrübeleri ile ilgilenerek, olaylara yükledikleri anlamları belirlemeyi sağlar (Baş ve Akturan, 2008). Çalışma, 2013-2014 eğitim-öğretim yılında, bir devlet ortaokulunun bireyselleştirilmiş eğitim programına tabi iki öğrenci dışında yirmi sekiz 8. sınıf öğrencisi ile gerçekleştirilmiştir. Örneklem grubu genel olarak orta düzey akademik başarıya sahiptir.

Veri Toplama Araçları ve Süreci

Veri toplama aracı olarak, ortaokul matematik terimleri listelenip alan eğitimi ışığında matematik terimleri ölçeği oluşturulmuştur. Ölçekte yer alan matematik terimleri, İlköğretim ve Ortaokul Matematik Dersi Öğretim Programları (MEB, 2009; MEB 2013) ve Matematik Sözlüğü (Large, 2011) taranarak belirlenmiştir. Veri toplama sürecinin öğrenciler için sıkıcı ve uzun sürmemesi, dolayısıyla araştırmanın güvenilirliğini olumsuz yönde etkilememesi amacıyla çok temel kavramları (basamak, bölük gibi) ve genel ifadeleri (uzunluk ölçüleri, zaman ölçme gibi) içeren terimler elenerek beş öğrenme alanından 152 terim korunmuştur.

Alan eğitimi araştırmaları, lise ve lisans öğrencilerinin tanımları doğru bir şekilde ifade etme ve problem çözme ya da ispat sürecinde tanımların rolünü anlama zorluklarını vurgulamaktadır (Dahlberg ve Housman, 1997; Edwards ve Ward, 2004; Zaslaysky ve Shir, 2005). McConnel (2008) öğrencilerin matematik konularını anlamada kelime öğretiminin etkisini incelediği çalışmada, on terimin listelendiği ve her terim için dört bölmelik (terim-tanım-cümle içinde kullanım-temsil eden resim veya diyagram) çalışma alanı oluşturulan terim quizleri hazırlamıştır. Bu şekilde bir terimin öğrenci için ne ifade ettiği hakkında daha zengin bilgi elde edilebilir. Ölçeğin hazırlanmasında, öğrenciler tarafından terimlere tanım vermenin kolay olmayacağı düşüncesinden hareketle, terimlerin ne anlama geldiğini kendi cümleleriyle yazmaları tercih edilmiştir. Bunun yanında öğrencilerin, sözel temsile ek olarak, terimlere matematiksel temsili oluşturan örnekler de vermeleri istenmiştir. Böylece sözel olarak doğru bir şekilde ifade edilemese de, matematiksel olarak durumu belirlemenin mümkün olması sağlanmıştır. Sonuç olarak ölçek bir ortaokul terimler listesi olarak tasarlanmış ve her terim için iki bölmenin yazılı olarak doldurulması hedeflenmiştir: terimlerin öğrenci için taşıdığı anlam ve terimlere ilişkin matematiksel örnekler. Matematik terimleri, matematik dersi öğrenme alanlarına göre gruplandırılarak farklı zaman dilimlerinde uygulanabilirliği sağlanmıştır.

Verilerin Analizi

Ölçekte yer alan matematik terimleri ve öğrenci görüşlerinden oluşan yazılı veriler doküman analizine tabi tutulmuştur. Öğrencilerin, terimleri matematiksel ve sözel temsil becerilerini yorumlamada araç olarak kullanmak üzere, her bir terim için çağrışım etki eden olası faktörler belirlenmiştir. Bu işlemde Thompson ve Rubenstein'in (2000) tespit ettiği faktörler çalışmamıza yön vermiştir. Öğrencilerin öğretim ve ana dilinin

Türkçe olması göz önünde bulundurularak, çeşitli sözlükler yardımıyla matematik terimleri için, kavram çağrışımını etkileyen başlıca yedi durum belirlenmiştir:

- Günlük dil ve bilim dilinde sesteş kelimeler: Öğrencilerin matematik dersinde karşılaştıkları terimlere daha önceki okul veya okul dışı yaşantılarında edindikleri farklı anlamları yüklemeleri ile öğrenmede çeşitli zorluklar ortaya çıkabilmektedir (Bingölbali, 2009). Günlük dil ve bilim dilinde, aynı disiplin içerisinde veya farklı disiplinlerde ortak olarak kullanılan sesteş kelimeler çağrışımına etki edebilir. Türkçe sözlüklerden terimlerin değişik alanlardaki tanımı incelenerek (matematik, günlük dil...) sesteş kelimelerin olası etkisi araştırılmıştır: etkisiz eleman, ardışık sayı, imkânsız olay, bir sayının kuvveti, kesirlerde genişletme, üslü sayılarda taban/üçgenin tabanı...
- Ses benzerliği ve Kelime kökleri: Terimler ses benzerliğinden dolayı farklı çağrışımlara yol açabilir: koni-huni, asal sayı-asıl ...
- İlişkili fakat anlamları farklı matematik terimleri: denklem-özdeşlik, çarpan-kat...
- Kombine matematik terimleri: Terimlerin yan yana gelmesi ile oluşan yeni terimlerde kelimelerden herhangi birinin çağrıştırdığı anlam kelime öbeğine genellenebilir veya yeni bir anlam oluşmasını sağlayabilir: üçgen eşitsizliği, örnek uzay, karesel sayı...
- Yabancı kökenli terimler: Türkçeye yabancı dilden geçen kelimelerin matematikte kullanılması çağrışımına engel olabilir: permütasyon, hipotenüs...
- Vurgu yapılan kelimeler: Türkçede sıfatlar ve sıfatların önüne getirilen “en, pek, daha” gibi kelimeler o sıfatın derecesini artırarak vurguya dayalı bir anlam oluşmasına sebep olabilir. Matematik terimleri içerisinde benzer yapılar vardır: en büyük ortak bölen, en küçük ortak kat, eşkenar üçgen...
- Sadece matematikte kullanılan terimler: Bir bilim dalına özgü kelimelerle öğrenciler günlük yaşantılarında karşılaşmadıklarında terimlerin anlaşılması daha zor olabilir: prizma, ondalık gösterim, medyan...

Bir terimin çağrışımına birden çok faktör etki edebilir. Örneğin “prizma” teriminin anlaşılmasındaki zorluk, sadece matematik alanına özgü bir terim olması ile birlikte yabancı kökenli olmasından da kaynaklanabilir. Faktörlerin belirlenmesi sürecinde, analizin güvenilirliğini sağlamak için türkçe ve yabancı dil bilgisi iyi derecede olan kişilerden görüş alınarak sonuçlar teyit edilmiştir. Matematik terimleri ölçeği sayesinde, terimlerle ilgili her bir öğrencinin sözel ve matematiksel temsilleri kavramla ilişki bakımından doğruluk değerleri tespit edilerek kodlanmış ve MS Excel tablolama yazılımına kaydedilmiştir:

- Matematiksel ve sözel ifadesi doğru olanlar: 1/1
- Matematiksel ifadesi doğru iken sözel ifadesi yanlış olanlar: 1/0
- Matematiksel ifadesi yanlış iken sözel ifadesi doğru olanlar: 0/1
- Matematiksel ve sözel ifadesi yanlış olanlar: 0/0

Sözel ifadelerin doğruluk değeri tespit edilirken, matematiksel olarak doğru bir açıklama veya tanımdan ziyade, terimin çağrışımına olumlu (doğru olarak kodlanmış) veya olumsuz (yanlış olarak kodlanmış) etkisi göz önüne alınmıştır. Her bir terim için doğruluk değerlerine karşılık gelen frekanslar (öğrenci sayısı) not edilmiştir ve maksimum frekans değerine göre terimler gruplandırılmıştır. Daha sonra verilerden merkezi bir noktaya göre değerlerdeki değişimi gösteren radar grafikler oluşturulmuştur. Bu grafik türü ile, böylece doğruluk değerlerinin baskın olduğu durumlarla ilgili bir resim ortaya konmuştur. Öğrencilerin terimlere yükledikleri anlam incelenerek, sahip oldukları çağrışımlar ortaya çıkarılmış ve çağrışımlara etki eden faktörler bazında veriler içerik ve betimsel analiz teknikleriyle analiz edilmiştir.

BULGULAR

Bulgular, öğrencilerin matematik terimlerini sözel ve matematiksel temsillerinin kavramla ilişki bakımından doğruluk değerleri dikkate alınarak dört alt başlıkta özetlenmiştir.

Her öğrencinin (öğrenci kodları 1/1 değerlerine göre sıralanmış halde grafiğin eksenlerine yerleştirilmiştir) terimleri matematiksel ve sözel temsil becerilerini gösteren sonuçlar Şekil 1; terimlerin matematiksel ve sözel öğrenci temsillerinin doğruluk değerleri bazında yaklaşık olarak frekans ve yüzde dağılımı ise Şekil 2’de özetlenmiştir.

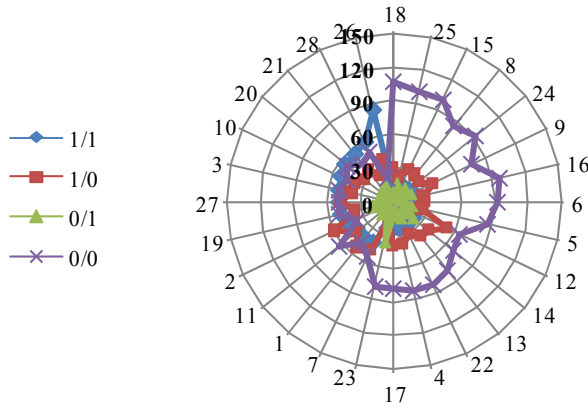

Şekil 6. Terimlerin Öğrenci Bazında Temsil Doğruluk Değerleri

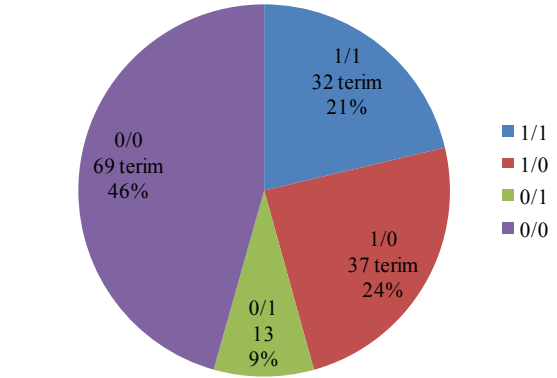

Şekil 7. Terimlerin Temsil Doğruluk Değerleri Bazında Dağılımı

Şekil 1 incelendiğinde, öğrencilerin yaklaşık yarısının (grafikğin sağ tarafındaki uç değerlere bakınız) terimlerin yarısından fazlası için ne sözel ne matematiksel olarak doğru temsiller üretmedikleri; hem sözel hem matematiksel temsilleri doğru olan öğrencilerin ise genel olarak terimlerin üçte birini pek fazla geçemedikleri anlaşılmaktadır (grafikğin sol tarafındaki uç değerlere bakınız).

Terimlere verilen matematiksel ve sözel temsiller ayrı ayrı değerlendirildiğinde, terimlerin %70'inin sözel olarak, %55'inin ise matematiksel olarak doğru bir şekilde ifade edilemediği gözlemlenmektedir.

Matematiksel ve Sözel Temsil Doğruluk Değeri Çoğunlukla “1/1” Olan Terimler

Öğrencilerin çoğunun matematiksel ve sözel temsillerin her ikisini de kavramla doğru bir şekilde ilişkilendirdiği terimler Şekil 3’de sunulmuştur.

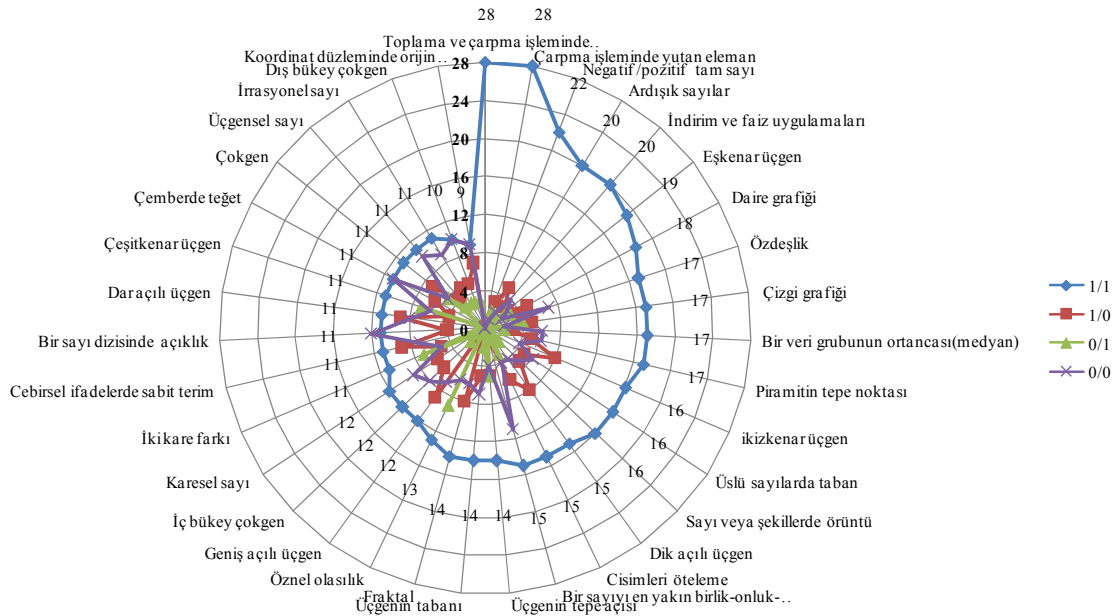

Şekil 8. Matematiksel ve Sözel Temsil Doğruluk Değeri Çoğunlukla “1/1” Olan Terimler

Öğrenciler 35 terimin matematiksel ve sözel temsillerini çoğunlukla doğru ifade etmişlerdir. Bu terimlerin sırasıyla, 16 tanesi (%46’sı) geometri ve ölçme, 11 tanesi (%31’i) sayılar ve işlemler, 4 tanesi (%11’i) cebir, 3 tanesi (%9’u) veri işleme ve 1 tanesi (%3’ü) olasılık öğrenme alanına aittir. Bulgular, grafikte yer alan çoğu terimin günlük dil ve bilim dilinde ortak kullanılan sestış kelimeler olması durumu ile açıklanabilir: toplama ve çarpma işleminde *etkisiz eleman*, çarpma işleminde *yutan eleman*, negatif/pozitif tam sayı, ardışık sayılar, *özdeşlik*, *çizgi grafiği*, *özel olasılık*, *eşkenar üçgen*, *üçgenin tabanı*... Sestış olmanın yanında, bu terimlerin

matematiksel anlamı günlük dildeki anlamına eş veya benzer olabilmektedir. Örneğin; toplama ve çarpma işleminde *etkisiz eleman* için 1 kodlu öğrencinin matematiksel ve sözel temsili Şekil 4’deki gibidir:

Toplama ve çarpma işleminde etkisiz eleman	X	Bir etkisiz eleman denir o sifata bir sayı etkisi olmayan gelirdir. Ama toplama ve çarpma da olabilir.
Örnek: $5 + 0 = 5$ $8 \cdot 1 = 8$		

Şekil 9. “Toplama ve Çarpma İşleminde Etkisiz Eleman” Terimine İlişkin 1 Kodlu Öğrenci Temsili

Terimin matematiksel ve sözel temsili doğru bir şekilde ifade edebilen öğrencinin zihninde “etkisiz” sözcüğü günlük dildeki “etkisi olmayan, tesirsiz” (TDK, 2014) anlamı ile örtüşmekte ve bunun sonucunda terim ‘işleme etki etmeyen bir eleman olarak’ çağrışım yapabilmektedir. Böylece öğrencinin terimi öğrenmesi kolay ve kalıcı olmaktadır. Öğrencilerin matematiksel ve sözel temsilleri doğru bir şekilde ifade edebilmelerinde sesteş veya vurgu yapılan kelimeler de olumlu yönde etki etmiştir. Örneğin, öğrencilerin üçte ikisinin “eşkenar üçgen” terimi için doğru temsiller üretebilmeleri, “eşkenar” sözcüğünün, sesteş olmakla birlikte (eş, kenar), üçgen terimini niteleyen bir sıfat olması ve dolayısıyla üçgenin kenarlarının eşliğine vurgu yapması ile açıklanabilir. “Öznel olasılık” gibi bazı terimler, öğrencilerin matematik derslerinde ve farklı disiplinlerde karşılaştığı sesteş ve anlamı benzer kelimelerdir. Öznel sözcüğü türkçe derslerinde “kişiye özgü düşünce, şahsi fikir” olarak öğrencilerin karşısına çıkmakta ve bu anlamı matematik dersindeki anlam ile benzerlik göstermektedir.

Matematiksel ve Sözel Temsil Doğruluk Değeri Çoğunlukla “1/0” Olduğu Terimler

Öğrencilerin çoğunun matematiksel temsili doğru, sözel temsili ise yanlış bir şekilde kavramla ilişkilendirdiği terimler Şekil 5’de sunulmuştur.

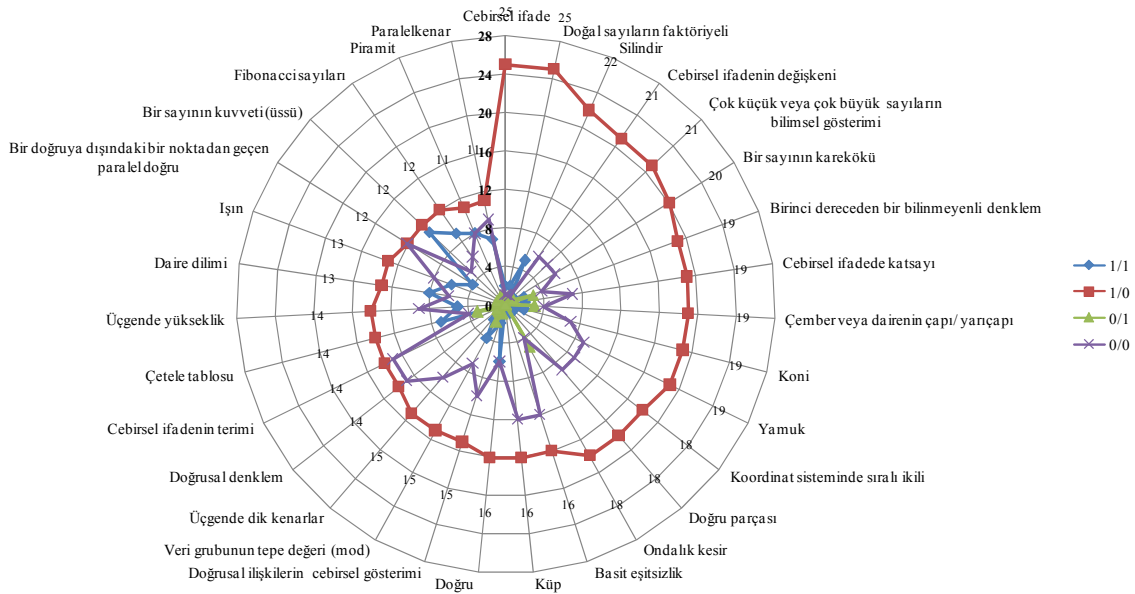

Şekil 10. Matematiksel ve Sözel Temsil Doğruluk Değeri Çoğunlukla “1/0” Olan Terimler

Öğrenciler 31 terimin matematiksel temsillerini çoğunlukla doğru ve sözel temsillerini yanlış ifade etmişlerdir. Bu terimlerin sırasıyla, 14 tanesi (%45’i) geometri ve ölçme, 9 tanesi (%29’u) cebir, 6 tanesi (%19’u) sayılar ve işlemler, 2 tanesi (%7’si) ise veri işleme öğrenme alanına aittir. Öğrencilerin çoğunlukla matematiksel temsili doğru, fakat sözel temsili yanlış olarak ifade ettikleri terimlere farklı öğrenme alanlarından örnek verecek olursak: doğal sayıların *faktöriyeli*, bir sayının kuvveti (üssü), ondalık kesir, cebirsel ifade, cebirsel ifadenin değişkeni, çetele tablosu, tepe değeri (mod)... Bulguları, terimlerin çağrışımına etki eden tek bir faktörle ilişkilendirmek oldukça güç gözükmektedir.

Öğrencilerin terimleri sözel olarak ifade zorlukları, bazı terimlerin kavramı çağrışım güçlerinin zayıf olması ile açıklanabilir. Örneğin “doğal sayıların *faktöriyeli*”, “*Fibonacci* sayıları” yabancı kökenli kelimelerden oluştuğundan öğrenci zihninde herhangi bir olumlu çağrışım yapması zordur. “*Piramit*”, “*silindir*” gibi terimler hem yabancı kökenli hem de günlük dil-matematik terminolojisinin ortaklaşa kullandığı kelimeler olmasına

rağmen sözel temsillere olumlu olarak yansımamıştır. “Bir sayının kuvveti (üssü)”, “yamuk” gibi terimler, günlük dil ve matematik terminolojisinde ortak kullanılan fakat günlük dildeki anlamları matematiksel anlamını karşılamayan, hatta yanıltıcı terimlerdir. Örneğin, 9 kodlu öğrencinin “bir sayının kuvveti (üssü)” için vermiş olduğu temsiller Şekil 6’deki gibidir:

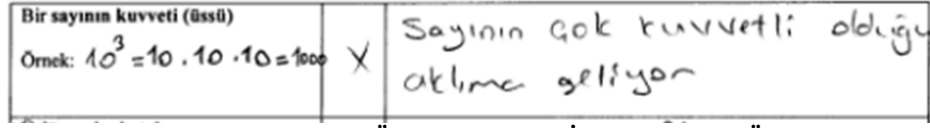

Şekil 11. “Bir Sayının Kuvveti (Üssü)” Terimine İlişkin 9 Kodlu Öğrenci Temsili

“Bir sayının kuvveti (üssü)” teriminde “kuvvet” kelimesinden dolayı, öğrenciler terimi “güçlü, yüksek, üstün, kuvvetli” gibi anlamlarda düşünmektedirler. Oysa ki negatif veya rasyonel sayıların kuvveti alındığında, duruma göre değerce daha küçük bir sayı elde edilebilmektedir. Öğrencilerin matematiksel temsilleri de, sözel temsillere paralel olarak, bir sayının kuvveti alındığında değerce büyük bir sayı vermesi ile alakalıdır, sınırlı örnekler olmasına karşın doğru olarak kabul edilmiştir. Öğrenciler sözel olarak günlük dilin etkisinde kalıp yanlış açıklamalar yapsalar da matematiksel görüntüsünü doğru kullanabilmektedir. Benzer şekilde “bir veri grubunun tepe değeri (modu)” teriminde de öğrenciler “tepe” sözcüğünün etkisinde kalarak veri grubundaki en büyük sayı değeri şeklinde sözel ifade bulunmuşlarsa da, matematiksel temsilleri genel olarak doğrudur. “Cebirsel ifade” terimi matematiğe özgü terim olması dolayısıyla sözel temsiller doğru bir şekilde verilememiştir. Fakat matematiksel temsilin çoğunlukla doğru olması, konunun 6. sınıftan itibaren her yıl kazanımlar arasında olması ile ilişkili olabilir. Cebir denilince öğrenci zihninde ilk olarak “x” canlanmaktadır ve çoğu öğrenci de örneklerinde “x” harfini kullanmıştır.

Matematiksel ve Sözel Temsil Doğruluk Değeri Çoğunlukla “0/1” Olan Terimler

Öğrencilerin çoğunun matematiksel temsili yanlış, sözel temsili ise doğru bir şekilde kavramla ilişkilendirdiği terimler Şekil 7’de sunulmuştur.

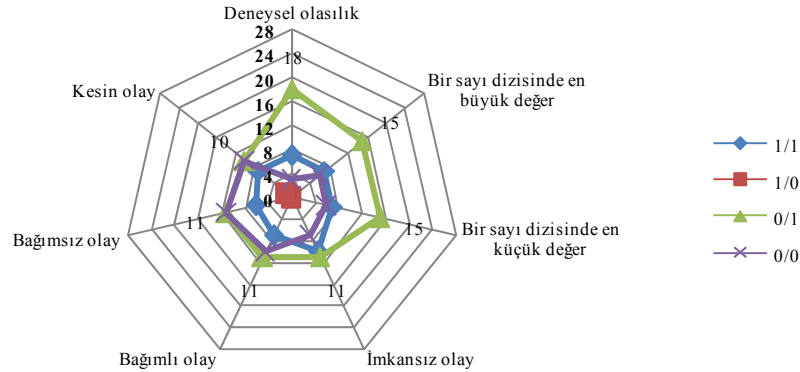

Şekil 12. Matematiksel ve Sözel Temsil Doğruluk Değeri Çoğunlukla “0/1” Olan Terimler

Öğrenciler 7 terimin matematiksel temsillerini çoğunlukla yanlış, sözel temsillerini ise doğru ifade etmişlerdir. Bu terimlerin 5 tanesi (%71’i) olasılık, 2 tanesi (%29’u) veri işleme öğrenme alanına aittir. Bu gruba giren terim sayısı oldukça azdır. Aslında öğrencinin bir terimi sözel olarak doğru temsil edebilirken, matematiksel temsilde zorlanması pek beklenen bir durum değildir. Öğrencilerin çoğunlukla matematiksel temsili yanlış, sözel temsili ise doğru olarak ifade ettikleri terimler, olasılık ve veri işleme öğrenme alanlarına aittir: deneySEL olasılık, bir sayı dizisindeki en büyük değer, bir sayı dizisindeki en küçük değer, imkansız olay... Bu terimlerin sözel olarak doğru ifade edebilmesini tek bir faktörle ilişkilendirmek güç olsa da büyük oranda sesteş kelimelerden matematiksel anlamı ile günlük dildeki anlamı benzer olanların etkisi olduğu gözlenmektedir. “İmkansız olay” terimi için 13 kodlu öğrenci temsili Şekil 8’deki gibidir:

dayanmaktadır. Bu terim matematikte sıranın önemli olduğu listeleme veya seçmelerde kullanılmaktadır. “Kesirlerde genişletme” teriminde “*genişletme*” kelimesinin günlük dildeki kullanımının matematiğe aktarılması olumsuz yönde bir çağrışıma sebep olmaktadır. Genişletme “geniş duruma getirme” (TDK, 2014) şeklinde tanımlanmaktadır. Genişletirken pay ve payda aynı sayı ile çarpıldığı için ayrıca değerlerinin de büyüyeceği düşünülmektedir. Öğrenciler daha önceki öğrenimlerinde doğal sayılarda çarpma işlemi yaparken çarpımın her zaman çarpanlardan büyük olduğunu fark etmiştir. Öğrenci daha önceki deneyimlerinden yola çıkarak “kesirlerde genişletme” işleminde sonucunun daha büyük olacağı yargısına ulaşmaktadır. Burada karşılaşılan zorluk, aşırı genelleme türünden bir kavram yanlışlığı ile ilişkilidir.

“En küçük ortak kat” terimi öğrencilerde sonucun çok küçük bulunacağı algısı oluşturmaktadır. Bu algının sebebi terimdeki “*en*” pekiştirme sıfatının “*küçük*” sıfatını pekiştirerek vurgunun o kelimeye yapılmasını sağlamasıdır. Öğrencilerin neredeyse tamamı bu terimin ne matematiksel ne de sözel temsilini doğru olarak verememiştir.

SONUÇ ve ÖNERİLER

Matematik terimlerini anlayabilmek öğrenmenin gerçekleşmesi için atılan ilk adımlardan biridir. Öğrenci zihninde terimlere ait olumlu veya olumsuz çağrışımlar saptanarak bu çağrışımların sebepleri ile matematiksel ve sözel temsillere etkisi tespit edilmeye çalışılmıştır. Araştırma bulguları, öğrencilerin çoğunlukla matematik terimlerini açıklamakta zorlandığını ve çoğu terimi anlayarak kullanmadığını ortaya çıkarmıştır. Bu sonuç matematik terminolojisi üzerine yapılan bazı çalışma sonuçları ile paralellik göstermektedir (Otterburn & Nicholson, 1976; Yüzerler ve Doğan, 2012).

Araştırma çerçevesinde, türkçe matematik terimleri için kavram çağrışımını etkileyen çeşitli durumlar belirlenmiştir ve öğrencilerin terimlere getirdikleri sözel ve matematiksel temsiller bu durumlar açısından yorumlanmıştır: Günlük dil ve matematik terminolojisinin ortak kullandığı sesteş kelimeler oldukça fazladır. Bu kelimelerden bazıları “etkisiz eleman”, “eğim” vb.- çağrışımı olumlu yönde etkilerken, bazıları “yamuk”, “kesirlerde genişletme”- ise olumsuz etkileyebilmektedir. Genel olarak, öğrenci matematik terminolojisini günlük hayatla ilişkilendirerek kullanabilirse, kendini geliştirerek başarısını artırabilir (Larson, 2007). Öğrencilerin sözel temsillerini doğru oluşturdukları terimler çoğunlukla günlük dilde kullanılan ve benzer anlamda olan sesteş kelimelerdir. Terimlerin büyük bir kısmı ise sözel ve matematiksel olarak yanlış ifade edilmiştir. Bunun sebebi olarak tek bir faktör gösterilememektedir. Yabancı kökenli terimlerin birçoğu – “histogram”, “permütasyon”, “trigonometri” vb.- çağrışımı olumsuz etkilemektedir. Bu terimlerin hangi dillerden alındığı ve orijinal anlamlarının araştırılarak öğretilmesi, kavram oluşum sürecinde etkili olabilir. Sadece matematiğe özgü olan terimlerin kullanımı genellikle okul ile sınırlı olduğundan çağrışım oluşturmuyor olabilir. Bazı kombine matematik terimleri içerisindeki bir sözcük kelime öbeğinin tamamını tesiri altına alarak çağrışımı olumsuz etkileyebilir. Örneğin; “örnek uzay” teriminde “örnek” sözcüğünden dolayı sadece birkaç örnek yazılacakmış gibi düşünülebilir. Oysaki “örnek uzay” oluşturulurken aynı durumların hepsi yazılmak zorundadır. Matematik terminolojisinde vurgu yapılan kelimeler “bir sayı dizisindeki en büyük değer”, “ikizkenar üçgen”, “imkansız olay” vb.- genel olarak çağrışımı olumlu yönde etkilerken “en küçük ortak kat” ve “en büyük ortak bölen” terimlerinde durum tersindedir. Öğretimde vurgu yapan kelimelerin etkisinin doğru bir biçimde öğrenciye sezdirilmesi önem taşımaktadır.

Öğrenciler matematiği kavramsal olarak anlamak yerine formülleri ezberleyerek işlem yapmayı öğrenmektedirler (Yenilmez ve Demirhan, 2013). Öğrencilerin, bazı terimleri sözel olarak ifade edemezken matematiksel olarak örnek verebilmeleri, matematik terimlerini tanımlama zorluğu ve daha çok işlemsel bilgilere sahip olduklarını göstermektedir.

Ortaokul matematik dersi öğretim programının genel amaçları arasında, öğrencilerin matematiksel dil ve terminolojiyi doğru kullanabilmeleri ve kavramların farklı temsillerini yapabilmeleri yer almaktadır. Araştırmanın bulguları öğrencilerin bu amaçları çoğunlukla edinemediklerini göstermektedir. Matematik derslerinde terimlerin dil ile ilişkisi gözetilerek öğretilmesine önem verilmelidir. Öğretmenler öğretim süreci boyunca terimleri öğrenme ve matematiği anlamının birbiriyle yakından ilişkili olduğunu unutmamalıdır (Thompson ve Rubenstein, 2000). Larson’un (2007) belirttiği gibi, terimlerin öğrenilmesi küçük bir adım olsa da büyük fikirlerin gelişmesi için bu küçük adımlara ihtiyaç olduğu unutulmamalıdır. Öğretmenler, her zaman öğrencilerin öğrenmesini destekleyecek yeni ve daha iyi yöntem arayışı içinde olmalıdır (McConnel, 2008). Sonuç olarak, öğretmenlere matematiksel terimlerin anlamlarını, kökenlerini araştırıp kavramın adıyla konunun ilişkisinin kavratılarak öğretimin gerçekleştirilmesi önem arz etmektedir. Matematik terimlerini bilmek demek, kitap (formal) tanımından ziyade terimin üstlendiği anlamı bilmektir ve öğrencileri bu şekilde düşünmeye teşvik etmek gerekir (Yüzerler ve Doğan, 2012). Terim öğretimi matematik öğretiminin bir parçası olarak düşünülmeli ve her farklı terim için uygun öğretim teknikleri geliştirilmelidir. Matematiğin sadece sayılar ve işlemlerden oluştuğu düşünülmemelidir.

KAYNAKLAR

- Adams, T. L. (2003). Reading mathematics: More than words can say. *The Reading Teacher*, 56(8), 786-795.
- Ainsworth, S. (2006). DeFT: A conceptual framework for considering learning with multiple representations. *Learning and Instruction*, 16(3), 183-198.
- Akkoç, H. (2006). Fonksiyon kavramının çoklu temsillerinin çağrıştırdığı kavram görüntüleri. *Hacettepe Üniversitesi Eğitim Fakültesi Dergisi*, 30, 1-10.
- Baş, T. ve Akturan, U. (2008). *Nitel araştırma yöntemleri* (1. Basım). Ankara: Seçkin Yayıncılık.
- Bingölbali, E. (2009). Matematiksel kavram yanlışları: sebepleri ve çözüm arayışları (s. 1-30). E. Bingölbali ve M. F. Özantar (Eds), *İlköğretimde karşılaşılan matematiksel zorluklar ve çözüm önerileri*. Ankara: Pegem Akademi.
- Dahlberg, R. P., & Housman, D. L. (1997). Facilitating learning events through example generation. *Educational Studies in Mathematics*, 33(3), 283-299.
- Edwards, B. S., & Ward, M. B. (2004). Surprises from mathematics education research: Student (mis)use of mathematical definitions. *The American Mathematical Monthly*, 111(5), 41-424.
- Kovarik, M. (2010). Building mathematics vocabulary. *International Journal for Mathematics Teaching and Learning*. Retrieved January 20, 2014 from <http://www.cimt.plymouth.ac.uk/journal/>
- Large, T. (2011). *Şekilli matematik sözlüğü*. (Çev. B. Kurt). Tübitak. (Orijinal çalışmanın yayın tarihi 2006)
- Larson, C. (2007). The importance of vocabulary instruction in everyday mathematics. *Math in the Middle Institute Partnership Action Research Project Report*, University of Nebraska-Lincoln. Retrieved January 25, 2014 from <http://scimath.unl.edu/MIM/files/research/LarsonC.pdf>
- McConnell, M. (2008). Exploring the influence of vocabulary instruction on students' understanding of mathematical concepts. *Math in the Middle Institute Partnership Action Research Project Report*, In partial fulfillment of the MAT degree department of mathematics University of Nebraska- Lincoln. Retrieved January 25, 2014 from <http://scimath.unl.edu/MIM/files/research/McConnellM.pdf>
- Milli Eğitim Bakanlığı [MEB]. (2009). *İlköğretim matematik dersi öğretim programı*. Ankara: MEB.
- Milli Eğitim Bakanlığı [MEB]. (2013). *Ortaokul matematik dersi 5.-8. sınıflar öğretim programı*. Ankara: MEB.
- Otterburn, M.K. & Nicholson, A.R. (1976). The language of CSE mathematics. *Mathematics in School*, 5(5), 18-20.
- Rubenstein, R.D. & Thompson, D.R. (2002). Understanding and supporting children's mathematical vocabulary development. *Teaching Children Mathematics*, 9(2), 107-112.
- Tall D.O. & Vinner S. (1981). Concept image and concept definition in mathematics, with special reference to limits and continuity. *Educational Studies in Mathematics*, 12, 151-169.
- Thompson, D. R., & Rubenstein, R. N. (2000). Learning mathematics vocabulary: Potential pitfalls and instructional strategies. *Mathematics Teacher*, 93(7), 568-577.
- Türk Dil Kurumu Güncel Türkçe Sözlük [TDK]. (2014). <http://www.tdk.gov.tr> adresinden 10.04.2014 tarihinde erişilmiştir.
- Yenilmez, K. ve Demirhan, H. (2013). 6. Sınıf öğrencilerinin bazı temel matematik kavramlarını anlama düzeyleri. *Dicle Üniversitesi Ziya Gökalp Eğitim Fakültesi Dergisi*, 20, 275-292.
- Yüzerler, S. ve Doğan, M. (2012). 6. ve 7. Sınıf öğrencilerinin matematiksel dili kullanabilme becerileri. *X. Ulusal Fen Bilimleri ve Matematik Eğitimi Kongresi*. Niğde Üniversitesi Eğitim Fakültesi, Niğde.
- Zaslavsky, O., & Shir, K. (2005). Students' conceptions of a mathematical definition. *Journal for Research in Mathematics Education*, 36(4), 317-346.

FEN BİLGİSİ VE SINIF ÖĞRETMENLERİNİN FEN KAVRAM ÖĞRETİMLERİ, KAVRAM YANILGILARINI SAPTAMA VE GİDERME ÇALIŞMALARININ DEĞERLENDİRİLMESİ

THE EVALUATION OF SCIENCE TEACHERS' AND PRIMARY TEACHERS' CONCEPT TEACHING AND THEIR ACTION TO DETERMINE AND ELIMINATE MISCONCEPTIONS

Tuğba ECEVİT
Hacettepe Üniversitesi
tubaeevit@hacettepe.edu.tr

Pınar ÖZDEMİR ŞİMŞEK
Hacettepe Üniversitesi
pozdem@hacettepe.edu.tr

ÖZET: Öğrencilerin önceki bilgileri ile yeni bilgileri arasında ilişki kurabilmeleri, ancak anlamlı öğrenmeleriyle mümkün olmaktadır. Bu nedenle öğrencilerin ön bilgilerinin tespit edilip kavram yanlışlarının belirlenmesi ve giderilmesi kavram öğretiminde önem taşımaktadır. Bu çalışmada öğretmenlerin kavram öğretimi için hangi yöntemi kullandıkları, kavram yanlışlarını nasıl saptadıkları, hangi kavram yanlışları ile karşılaştıkları ve nasıl gidermeye çalıştıklarının belirlenmesi amaçlanmıştır. Çalışma grubunu 2013-2014 eğitim-öğretim yılında Sivas ilinde görev yapan 5 fen bilgisi ve 5 sınıf öğretmeni oluşturmaktadır. Araştırma nitel bir çalışma olup betimleyici bir araştırmadır ve veri toplama aracı olarak yapılandırılmış görüşme, gözlem ve doküman analizi yöntemleri kullanılmıştır. Elde edilen veriler içerik analizi yöntemi ile analiz edilmiştir. Elde edilen bulgulara göre öğretmenlerin özel öğretim yöntemlerinden bazılarını uyguladıkları ama sunuş yoluyla kavram öğretimini de kullanmaya devam ettikleri gözlemlenmiştir. Öğretmenlerin karşılaştıkları kavram yanlışları ısı-sıcaklık, kütle-ağırlık, kuvvet-hareket, elektrik, ışık-ses, madde, hücre, solunum-fotosentez, kalıtım konuları ile ilgilidir. Öğretmenlerin büyük çoğunluğu yaparak yaşayarak öğrenme yolları ile kavram yanlışlarını gidermeye çalıştıklarını belirtmişlerdir.

Anahtar sözcükler: Kavram öğretimi, Kavram yanlışlarını saptama, Kavram yanlışlarını giderme, Fen bilgisi öğretmenleri, Sınıf öğretmenleri.

ABSTRACT: It can only be possible for students to relate their new knowledge with the old one through meaningful learning. Therefore, in teaching of the concepts it is important that the students' preliminary information be identified and their misconceptions be determined. It is aimed in this study to determine which methods teachers use for concept teaching, how they determine misconceptions, which misconceptions they encounter and how they try to resolve these. The study group consists of 5 science teachers and 5 primary teachers working in Sivas city during 2013-2014 academic year. The study is a qualitative one and a descriptive study and structured interview, observation and document analysis methods were used as the data gathering tool. The data obtained was analyzed by means of content analysis method. According to the obtained data, it has been observed that the teachers use some of the special teaching methods but also continue to use concept teaching through presentations. Misconceptions that teachers encounter are related to the subjects of heat-temperature, mass-weight, force-motion, electricity, light-sound, substance, cell, respiration-photosynthesis, heredity. A great majority of the teachers have stated that they try to eliminate misconceptions through learning by experience.

Key words: Concept Teaching, Determination of misconceptions, Elimination of misconceptions, Science teachers, Primary teachers.

ÖĞRETMEN ADAYLARININ YAŞAM BOYU ÖĞRENME EĞİLİMLERİNİN ÇEŞİTLİ DEĞİŞKENLER AÇISINDAN İNCELENMESİ

Hatice GUZEL*

*Necmettin Erbakan Üniversitesi, Ahmet Keleşoğlu Eğitim Fakültesi,
hguzel@konya.edu.tr

Imran ORAL*

*Necmettin Erbakan Üniversitesi, Ahmet Keleşoğlu Eğitim Fakültesi,

*Necmettin Erbakan Üniversitesi, Ahmet Keleşoğlu Eğitim Fakültesi,
Fizik Eğitimi Anabilim Dalı, Meram, Konya/ TURKEY
oralimran@konya.edu.tr

ÖZET: Asırlar boyunca toplumlar, kendini geliştiren ve yaşam boyu öğrenme becerilerine sahip bireylere gereksinim duymuştur. Yaşam boyu öğrenme, bireyin, beceri, ilgi ve yeterliliklerini geliştirmek amacıyla yaşamı boyunca devam eden öğrenme sürecidir. Yaşam boyu öğrenme, bireylerin bilgi toplumuna uyum sağlamaları ve yaşamın tüm evrelerine etkin bir şekilde katılmalarına da imkân sağlar. Günümüzde Öğrenme, sadece sınıf ortamında gerçekleşmeyip internet erişiminin olduğu her noktada gerçekleşebilmektedir.

Bu araştırmanın amacı, öğretmen adaylarının yaşam boyu öğrenme eğilimlerini belirlemek ve bu eğilimlerin internet kullanım süresi, cinsiyet ve öğrenim görülen ana bilim dalı değişkenleri açısından farklılık gösterip göstermediğini ortaya koymaktır. Araştırmanın çalışma grubunu Necmettin Erbakan Üniversitesi, fizik, matematik, kimya, biyoloji eğitimi anabilim dallarında öğrenim gören 411 öğretmen adayı oluşturmaktadır. Araştırma verileri, Coşkun (2009) tarafından geliştirilen "Hayat Boyu Öğrenme Eğilimlerini Belirleme Ölçeği" ile elde edilmiştir. Verilerin analizinde SPSS 18 Paket programı kullanılmıştır.

Öğretmen adaylarının "Yaşam Boyu Öğrenme Eğilimleri Ölçeğinden" aldıkları ortalama puanların, ölçek ortalama puanından düşük olduğu belirlenmiştir. Öğretmen adaylarının yaşam boyu öğrenme eğilimlerinin düşük olduğu söylenebilir. Öğretmen adaylarının yaşam boyu öğrenme eğilimleri, internet kullanım süresi, cinsiyet ve öğrenim görülen ana bilim dalı değişkenleri açısından istatistiksel olarak anlamlı bir farklılık göstermemiştir. Ancak "Yaşam Boyu Öğrenme Eğilimleri Ölçeği" nin alt boyutlarından "Öğrenmeyi Düzenlemede Yoksunluk" puan ortalamalarına göre bölümler arasında anlamlı bir farklılık bulunmuştur. Biyoloji anabilim dalı öğretmen adaylarının "Öğrenmeyi Düzenlemede Yoksunluk" puan ortalamaları, diğer anabilim dallarında öğrenim gören öğretmen adaylarına göre düşük bulunmuştur.

Anahtar Kelimeler: Yaşam Boyu Öğrenme, Öğretmen Adayı, Öğrenme Eğilimi Ölçeği, İnternet kullanımı.

INVESTIGATION OF LIFELONG LEARNING TENDENCIES OF CANDIDATE TEACHERS IN TERMS OF DIFFERENT VARIABLES

Hatice GUZEL

Necmettin Erbakan University, Ahmet Kelesoglu Education Faculty,
Department of Physics Education, Meram, Konya/ TURKEY
hguzel@konya.edu.tr

Imran ORAL

*Necmettin Erbakan University, Ahmet Kelesoglu Education Faculty,
Department of Physics Education, Meram, Konya/ TURKEY
oralimran@konya.edu.tr

ABSTRACT: Over the centuries, societies have needed to have individuals who developed themselves and have lifelong learning skills. Lifelong learning is an ongoing learning process to develop skills, interests and competencies of individual during life. Lifelong learning enables individuals to adapting to the information society and to participating effectively in all stages of life. Nowadays, learning does not only take place in the classroom, It occurs at everypoints which have Internet Access.

The purpose of this research is to figure out the lifelong learning tendencies of candidate teachers and to figure out whether these tendencies show any difference in terms of variables of internet usage time, gender and alma mater department. The study group is composed of 411 candidate teachers studying at physics, mathematics,

chemistry and biology education departments of Necmettin Erbakan University. The research data was obtained through the "Scale of Determining Lifelong Learning Tendencies" developed by Coskun (2009). The SPSS18 package program was used to analysis of data.

It was determined that candidate teachers' mean score of "Lifelong Learning Tendencies Scale" is lower than the mean score of the scale. It can be stated that lifelong learning tendencies of candidate teachers are low. The lifelong learning tendencies of candidate teachers has not been showed statistically any significant difference in terms of variables of internet usage time, gender and alma mater department. However, according to the average score of sub-dimension called "Learning in Regulation Deprivation" of "Lifelong Learning Tendencies Scale", a significant difference has been found between departments. The average score of sub-dimension called "Learning in Regulation Deprivation" of candidate teachers from biology education department was found lower then the other departments.

Key words: Lifelong learning, Teachers, Learning tendency survey, Internet usage.

IMPACT OF EXPLICIT-REFLECTIVE AND HISTORY BASED INSTRUCTION ON PRESERVICE SCIENCE TEACHERS' UNDERSTANDING OF NATURE OF SCIENCE

Volkan GÖKSU

Oktay ASLAN

Murat ÖZEL

In this study, it was investigated the impact of explicit-reflective and history based instruction on preservice science teachers' (PSTs) understanding nature of science (NOS). One-group pretest-posttest experimental design was used. In this design, differences between pre and posttests scores were assessed. The participants of this research consisted of 62 preservice science teachers who enrolled a public university in Turkey. To assess PSTs' understandings of NOS, 17 items which were purposefully selected from the Views on Science-Technology-Society (VOSTS) Questionnaire were used. In the experimental course, activities prepared based on explicit-reflective, and histories of science were taught throughout 10 weeks. After experimental instruction, the items selected from the VOSTS Questionnaire were administered as pre and posttest. Based on data analyses, it was found that explicit-reflective and history based instructions impacted positively PSTs' understandings of NOS. In particular, PSTs' views on nature of observations, nature of scientific models, hypothesis, theories, laws and epistemological status of scientific knowledge significantly changed from naive to realistic. In light of findings, implications for teaching the nature of science will be discussed.

Keywords: Nature of Science, Explicit-Reflective and History Based Instruction, Preservice Science Teachers' Understandings

BİR PROBLEMİ BEŞ FARKLI YOLDAN ÇÖZMEK, BEŞ PROBLEMİ BİR YOLDAN ÇÖZMEKTEN DAHA MI İYİDİR?

IS IT BETTER TO SOLVE ONE PROBLEM BY FIVE DIFFERENT WAYS THAN TO SOLVE FIVE DIFFERENT PROBLEMS BY ONE WAY?

Emre EV ÇİMEN
Eskişehir Osmangazi Üniversitesi
evcimen@ogu.edu.tr

Kürşat YENİLMEZ
Eskişehir Osmangazi Üniversitesi
kyenilmez@ogu.edu.tr

ÖZET: Problem çözme, matematik eğitiminin en temel amaçlarından birisidir ve öğretim programının içerisinde yer alan her konu için geliştirilmesi gerekli bir beceri olarak ele alınmaktadır. Problem çözme “bir matematik sorusuna cevap vermek, kısa yoldan ve hızlı işlem yaparak sonucu bulmak” şeklinde basite indirgenemeyecek kadar önemli bir düşünme becerisidir. Matematik öğretmen adaylarının problem çözmenin yapısı ve süreci hakkında doğru bilgilerle donatılmaları, mesleklerinde öğrencilerinin problem çözme becerilerinin geliştirilmesinde doğru yol yöntem ve yaklaşımı kullanmaları açısından önemli görülmektedir. Bu düşünceden hareketle, araştırmada, ilköğretim matematik öğretmenliğinde okuyan öğretmen adaylarının George Polya tarafından söylenen “Bir problemi beş farklı yoldan çözmek, beş problemi bir yoldan çözmekten daha iyidir” sözü hakkındaki düşüncelerini belirlemek amaçlanmıştır. Araştırma öğretmen adaylarının görüşlerini betimlemeye yönelik nitel bir çalışmadır ve 41 matematik öğretmen adayı ile gerçekleştirilmiştir. Sonuçta öğretmen adaylarının yaklaşık %75’i bir problemi farklı yollardan çözmenin birden çok problemi bir yolla çözmekten daha faydalı olduğunu söyleyerek Polya’nın sözüne katılmışlar ve farklı stratejileri öğrenmenin çok yönlü düşünme becerisini geliştirdiğini belirtmişlerdir.

Anahtar sözcükler: matematik eğitimi, problem çözme, George Polya.

ABSTRACT: Problem solving is one of the essential objectives of mathematics education and is considered as a skill to be developed in almost all subjects within mathematics curriculum. Problem solving is a significant thinking skill that can not be reduced to simply “answering a mathematics question or obtaining the result using a shorter way or via quicker processing”. We think it is important to train mathematics teacher candidates with correct information on the structure and process of problem solving so that they can use the correct methods to improve students’ problem solving skills in their future teaching career. Having this idea as our motivation, we aimed to determine what elementary mathematics teacher candidates think about George Polya’s famous saying: “It is better to solve a problem by five different ways than to solve five different problems by one way”. This research is a qualitative study realized with 41 teacher candidates. As a result, %75 of the teacher candidates agreed with Polya’s saying by stating that “solving a problem by five different ways is better than solving many problems by one way” and also stated that learning different strategies improves multi-faceted thinking skill.

Key words: mathematics education, problem solving, George Polya.

GİRİŞ

Problem çözme matematik öğretiminin en temel taşlarından biridir. Alanyazın incelendiğinde, matematikte başarılı olmanın yolunun problem çözme becerisinin gelişimi ile doğrudan ilişkili olduğu görülmektedir (Wilson, Fernandez & Hadaway, 1993). Öğrencilerin problem çözme becerilerini geliştirmeye yönelik çalışmalarda; (1) problemi anlama, (2) çözümü planlama, (3) planı uygulama, (4) çözümün doğruluğunu ve geçerliğini kontrol etme ve (5) çözümü genelleme ve benzer/özgün problem kurma süreçlerinin gözetilmesi gerektiği vurgulanmaktadır (Polya, 197; Schoenfeld, 1992). Bu süreçlere yönelik beklenen göstergelerden birisinin ulusal programlarda ve uluslararası matematik öğretim standartlarında “problemin farklı çözüm yollarını değerlendirme” ye önem verildiği görülmektedir (Xie, 2004).

George Polya (1957) “nasıl çözmeli” eserinde matematik öğretmenlerinin ilk görevlerinin öğrencilerinin problem çözme becerilerini geliştirmek olduğu vurgusunu yapmıştır. Polya tarafından söylenen “Bir problemi beş farklı yoldan çözmek, beş problemi bir yoldan çözmekten daha iyidir” sözü Polya’nın problem çözme konusundaki yaklaşımını ortaya koymaktadır. Dr. Polya Stanford Üniversitesi’nde (1887-1985) görev yapmış

matematik bilimi ve eğitimine önemli katkılar sağlamış bir matematikçidir ve matematik eğitiminde problem çözenin babası olarak bilinmektedir. Polya bir diğer veciz sözünde "bir problem 24 saat içerisinde çözülebiliyorsa problem değildir" demekle problem çözmeye iki hususa dikkat çekmek istemektedir. Bunlardan ilki; kısa sürede çözülen problemin daha önce karşılaşılmış bir durum olması ve artık bu yönü ile güçlük özelliği taşıyamamasıdır. İkincisi de benzer bir çözüm yolu ile çözülmüş bir problemle karşılaşılmış olunabileceğidir. Benzer şekilde aynı yolla çözülen bir başka problemin de gerçek anlamda problem özelliği taşımayacağı değerlendirilmektedir. Bu bakış açısı ile, matematik derslerinde yer alan pek çok problem gerçek anlamda problem özelliği taşımamaktadır. Oysa ki, gerçek hayatta karşılaştığımız problemler, nasıl çözüm bulunacağı bilinmeyen, hatta çözüme nereden başlanacağına dahi kestirilemediği durumlar, güçlüklerdir. Dolayısı ile matematik eğitiminde öğrencilerin problem çözmeye becerisini geliştirme yolu öğrencileri alışılmış (rutin) olmayan problemler ile çalıştırmaktan ve problemin farklı çözüm yollarını araştırmalarını sağlamaktan geçmektedir. Bu aynı zamanda öğrencilerin muhakeme becerilerini de geliştirmekte ve öğrencilerin benzeri pek çok güçlükle baş edebilmelerini mümkün kılmaktadır. Probleme yönelik farklı çözüm yollarını, stratejilerini araştırmak, öğrencilerin başarılı problem çözen bireyler olmalarına katkı sağlamaktadır (Bransford & Stein, 1984; Soylu & Soylu, 2006). Öğrencilerin problem çözmeye tek yol izlemelerinin, öğrencilerin yaratıcı ve esnek düşünme kabiliyetlerini zamanla kaybetmelerine yol açtığı düşünülmektedir. Benzer şekilde, öğrenciler farklı yollar aramanın gerekliliğine inançlarını kaybetmekte ve risk alma konusunda daha çekingen olmaktadır. Ek olarak, tek bir yol ile problem çözmeye çalışmaları yapıldığında öğrenciler, işlemsel bilgi kazanım sürecinde kavramsal bilgi ve anlayışlarını yüksek bir olasılıkla kaybetmektedirler (Narode, Board & Davenport, 1993).

Bu çalışmada, öğretmenlerin matematik öğretiminde öğrencileri ile yalnız tek çözümü olan, doğru ve hızlı sonuç bulmaya dayalı bir yaklaşımla çalışmaları yerine, alternatif çözümler barındıran problemlerle çalışmaları önemli görülmüştür. Buradan hareketle, Geleceğin öğretmenlerinin bu konudaki düşüncelerini ortaya koyarak, öğretmen adaylarının tek yolla çözülen pek çok problem yerine bir problemin farklı çözüm yollarını önemseyen bireyler olarak eğitilmelerinin gerekliliğine dikkat çekilmek istenmiştir.

YÖNTEM

Araştırmada, ilköğretim matematik öğretmenliğinde okuyan öğretmen adaylarının Polya tarafından söylenen "Bir problemi beş farklı yoldan çözmek, beş problemi bir yoldan çözmekten daha iyidir" sözü hakkındaki düşüncelerini belirlemek amaçlanmıştır. Araştırma öğretmen adaylarının görüşlerini betimlemeye yönelik nitel bir çalışmadır ve seçmeli bir ders olan Problem ve Problem Çözme Öğretimi dersi kapsamında 2. ve 3. sınıfta okuyan toplam 41 matematik öğretmen adayı ile gerçekleştirilmiştir. Öğretmen adayları ile gerçekleştirilen yarı yapılandırılmış görüşmede, öğrencilerden Polya'nın görüşüne katılıp katılmadıklarını gerekçeleri ile birlikte, ayrıntılı bir biçimde, açık anlaşılır bir dil ile, sunmaları istenmiştir. Verilerin analizinde içerik analizi uygulanmıştır. İçerik analizinde üç farklı görüşe, temaya ulaşılmıştır. Bunlar " (1) Bir problemin beş farklı çözüm yolunu bilmek iyidir, (2) Beş problemin bir çözüm yolunu bilmek iyidir ve (3) Her ikisi de iyidir " biçiminde verilebilir. Bulgular bölümünde her üç temaya ait kategori ve kodlar oluşturulmuş, tablolandırılmış ve tabloyu somutlaştırır özellikte seçilen örnek öğrenci görüşleri ile birlikte sunulmuştur. Görüşlerin hangi öğrenciye ait olduğu bilgisi, öğrencilerin sıralaması Ö-Numara biçiminde (Ö-1: Birinci öğrenci örneğinde olduğu gibi) sunulmuştur.

BULGULAR

Bulgular bölümünde ulaşılan üç farklı görüş sırası ile "Bir problemin beş farklı çözüm yolunu bilmek iyidir", "Beş problemin bir çözüm yolunu bilmek iyidir" ve "Her ikisi de iyidir" alt başlıkları ile sunulmaktadır.

Bir Problemin Beş Farklı Çözüm Yolunu Bilmek Daha İyidir

Yapılan incelemeler sonucu, 31 öğretmen adayının "bir problemin beş farklı çözüm yolunu bilmenin daha iyi olduğu" düşüncesinde George Polya'ya paralel bir düşünce sergiledikleri bulgusuna ulaşılmıştır. Bu her dört kişiden üçünün bu düşüncede olduğunu göstermektedir. Öğretmen adaylarının bir problemin beş farklı çözüm yolunu bilmenin beş problemin bir çözüm yolunu bilmekten neden daha iyi olduğu konusundaki açıklamaları incelenerek aşağıda Tablo 1'de verilen kategoriler ve kodlar oluşturulmuştur. Burada bir problemin beş farklı çözüm yolunu bilmenin beş problemin bir çözüm yolunu bilmekten daha iyi olması matematiksel bir biçimde $1P > 5P > 1Ç$ kısaltması ile verilmiştir.

**Tablo 1. "Bir Problemin Beş Farklı Çözüm Yolunu Bilmek Daha İyidir"
Temasına Ait Kategori, Kod ve Temalar**

Tema	Kategori	Kod	Frekans
		Bakış açısını zenginleştirme Çok yönlü düşünme	31

	Yaklaşım Katkı	Alternatif üretme Ezbercilikten uzaklaştırma Tekdüzelikten çıkarma	
1 P 5Ç > 5P 1Ç	Düşünmeye Katkı	Analitik düşünme Yaratıcı düşünme	17
	Zihinsel Yeteneklere Katkı	Zihinsel yetenekler Akıl yürütme yeteneği Muhakeme yeteneği	29
	Yaşama Katkı	Anlayış kazandırma Hayatı kolaylaştırma	18
	Problem Çözmeye Katkı	Farklı problem çözümlerine yardım	16
	Özellik	Kolay hatırlanabilir Eğlenceli, zevkli	11
	Nitelik	Az problem çok kazanım	27

Tablo 1'de yer alan kodlara ilişkin örnek öğretmen adayı ifadelerinden bazılarını aşağıda yer verilmektedir.

Tamamen katılıyorum. Tek bir çözüm yolunu bilmek insana tekdüze bakış açısı kazandırır. İnsan farklı çözüm yollarını araştırdığında normal yaşantısında problemleri daha kolay çözer. Problemlerin çözümleri için farklı alternatifler kolaylıkla üretebilir. [Ö - 39]

Bir problem için farklı çözüm yolları bulabilmek beş farklı biçimde düşünmek demektir. Farklı yolları bulmaya çalışmak akıl yürütmemizi sağlar ve farklı problemlerin çözümlerine de yardımcı olur bence. [Ö - 41]

Bir problemin birden çok çözüm yolunu bilmek bizim ileride daha farklı problemlerle karşılaştığımızda daha kolay sonuca ulaşmamızda yardımcı olur. Yani olaylara sorunlara başka pencerelerden bakma imkanı tanır. Daha geniş düşünmemizi sağlar. [Ö - 38]

31 öğretmen adayı da farklı ifadelerle de olsa bir problemin beş farklı çözüm yolunu bilmenin öğrencilerin bakış açısını değiştireceği, çok yönlü düşünme sağlayacağı ve dolayısı ile bireylerin yaklaşımına katkı sağlayacağı düşüncesindedirler. Öğretmen adaylarının aşağıda örnek verilen ifadelerinden de görüldüğü gibi, problemin farklı çözüm yollarını araştırmanın, bilmenin öğrencilerin düşünme biçimlerine, zihinsel yeteneklerine ve dolayısı ile yaşamlarına katkı sağladığı bulgusuna ulaşılmıştır..

Problem çözmek doğru işlemleri kullanarak doğru sonuca ulaşmaktan ziyade kişinin muhakeme yeteneğini kullanması ve geliştirmesini amaçlamaktadır. Bir problemi çözerken farklı yollar denemek kişinin analitik düşünmesini sağlar. Analitik düşünen kişi de hayata at gözlükleri ile bakmak yerine farklı farklı pencerelerden bakar. Beş farklı yol bilmek insanın yaratıcılığını geliştirir. [Ö - 21]

Tek bir çözümün olması o çözüm yolunu bulamayan biri için zordur, çünkü soruyu çözemez. Ama alternatif çözümler olursa birey sonuca daha kolay ulaşır. [Ö - 9]

Bir problemin 5 farklı çözüm yolunu bilmek bence daha iyidir. Çünkü bazı zamanlarda tek çözümünü biliyorsan unutabilirsin ama 5 çözümünü de biliyorsan mutlaka biri hatırlanır. [Ö - 40]

Bir konu hakkında farklı ve çeşitli alternatifler türetebilmek daha sağlıklıdır. Ezbercilikten uzaklaştırır. Yaratıcı düşünmeyi sağladığı için kişisel gelişimimize önemli katkılar sağlar. Bir problemin çözüm yolu diğer problemlerde uygulanıyorsa bu şey katmaz, ezberlendiğini gösterir. Bir problemi farklı yollarla çözmek kişiye zihinsel çok şey katar. Farklı problemlerin de üstesinden gelir. [Ö - 27]

Öğretmen adaylarının düşünceleri incelendiğinde, aynı yolla farklı problemler çözenin kendilerine çok da katkı sağlamayacağı düşüncesindedirler. Bunun nedenini iyi puan almak, doğru sonuca en kısa yoldan ulaşmak amaçlı yetiştirilme biçimlerine bağlamaktadırlar. Aşağıda verilen ifade bu durumu ortaya koyar niteliktedir.

Ben bu söze sonuna kadar katılıyorum. Sebebi şu: Günümüzde hepimiz iyi puanlar alabilmek için sadece doğru sonuca en kısa yoldan ulaşmak için yetiştirilen bireyler olduk. Bunun için de bir problemin beş farklı çözüm yolunu bilmekten ziyade beş problemin bir çözüm yolunu bilmeyi hedef edindik. Öyle böyle bir yerlere geldik

ama çoğu kişi üniversite sıralarında yorum yapmaktan aciz. Bizlerin farklı bakış açıları, farklı ufukları, farklı çözüm önerileri olmazsa bizlerin yetiştireceği öğrencilerden ne beklenir? [Ö - 11]

Beş Problemin Bir Çözüm Yolunu Bilmek Daha İyidir

4 öğretmen adayının beş problemin bir çözüm yolunu bilmenin bir problemin beş farklı çözüm yolunu bilmekten daha iyi olduğunu düşündüğü bulgusuna ulaşılmıştır. Oluşturulan kategori ve kodlar matematiksel bir biçimde $5P 1Ç > 1P 5Ç$ kısaltması ile aşağıda Tablo 2 'de sunulmuştur.

Tablo 2. "Beş Problemin Bir Çözüm Yolunu Bilmek Daha İyidir" Temasına Ait Kategori, Kod ve Temalar

Tema	Kategori	Kod	Frekans
5 P 1Ç > 1P 5Ç	Deneyim	Tecrübe kazandırma Pratiklik	4
		Çok soru tipi görme Aynı yolla çözüm Kolay hatırlama	
	Zaman	Hızlı çözüm Zaman kaybını önleme	2
	Sınav	Sınav başarısına katkı	3
	Nitelik	Çok problem çok kazanım	3

Beş problemin bir çözüm yolunu bilmek daha iyidir görüşünde olan öğrencilerin problem çözmenin daha çok sınavlar için öğrencilere gerekli olduğu, farklı çözüm yollarını araştırmanın zaman kaybı olduğu düşüncesinde oldukları belirlenmiştir. Bu durumun öğrencilerin aldıkları eğitimin bir sonucu olduğu değerlendirilmektedir (Korkmaz, Gür & Ersoy, 2004). Öğretmen adaylarının niteliğine bakılmaksızın niceliksel açıdan çok problem çözmenin daha önemli bir kazanım olduğu düşüncesinde oldukları bulgusuna ulaşılmıştır. Aşağıda örnek seçilen bazı öğrenci ifadelerine yer verilmiştir.

Aslında bu bana pratiklik gibi geliyor. Zamana karşı yarıştığımız sınavlar için aynı tip sorulardan çokça çözmeliyiz ki kazanabilelim. [Ö - 33]

Katılıyorum çünkü günlük hayatta problem çözmede esas olan problemin çözümüne ulaşmaktır. Hangi yoldan ulaşıldığı çok önem arz etmez. Ne kadar çok problem çözersek o kadar iyi, yolu önemli değil. [Ö - 21]

Amaç problem çözmek olunca beş farklı çözüm yolunu bilmek ve öğrenmek zaman kaybı olacaktır. [Ö - 23]

Bir problem yerine beş problem çözmek sadece bir çözüm yolu bilinse bile daha çok işimize yarar. Bize deneyim kazandırır. [Ö - 29]

Her İkisi de İyidir

Burada beş problemin bir çözüm yolunu bilmenin bir problemin beş farklı çözüm yolunu bilmenin her ikisinin de eşdeğer öneme sahip olması durumu 6 öğretmen adayı tarafından dile getirilmiş olup; oluşturulan kategori ve kodlar matematiksel bir biçimde $5P 1Ç = 1P 5Ç$ kısaltması ile Tablo 3'de verilmiştir.

Tablo 3. "Her İkisi de İyidir" Temasına Ait Kategori, Kod ve Temalar

Tema	Kategori	Kod	Frekans
5 P 1Ç = 1P 5Ç	Birini Tercih	İhtiyaca bağlılık	4
		Keyfilik	
	Birlikte Kullanım	Gereksinim	3

Öğretmen adayları, "beş problem bir çözüm veya bir problem beş çözüm"den tercih ve ihtiyaca bağlı olarak birinin seçilmesi veya her ikisinin birlikte kullanımının gerektiği düşüncesindedirler.

Bu söze katılıyorum çünkü bir problem her zaman aynı yolla çözülemeyebilir, birden fazla yol bilmek çözümü garantilemektedir. Aynı zaman da katılmıyorum çünkü ne kadar çok problem çözersek o kadar iyi. İhtiyaca göre seçmek ve kullanmak en iyisi. [Ö - 25]

Ben bu söze kısmen katılıyorum. Bir problemin birden çok çözümünü bilmek akıl yürütme açısından gerçekten güzel. Beş problemin bir çözüm yolunu bilmek daha çok problemi çözüme ulaştırmak demektir. Her iki tür ihtiyaca bağlı olarak birlikte kullanılmalıdır. [Ö - 26]

SONUÇ VE ÖNERİLER

Yıllar önce Polya, problem çözme becerisinin gelişiminde aynı yoldan ne kadar çok problemin çözülmüş olmasından ziyade bir probleme yönelik farklı çözümlerinin araştırılması, stratejilerin geliştirilmesinin önemini vurgulamıştır. Ancak her ne kadar vurgu bu yönde olsa da, işleyişin ölçme değerlendirme sistemlerinin yapısının, bireyleri farklı yollarla çözülen problemlerden ziyade sayıca çok problem çözmenin, doğru ve hızlı sonuç veren yolun önemli olduğu gibi bir düşünceye yönlendirdiği görülmektedir. Bu araştırma öğretmen adaylarının önemli bir çoğunluğunun bir problemi farklı yollardan çözmenin bireye katkısının pek çok açıdan daha fazla olacağını düşündüğünü göstermektedir ancak öğretmen adayları bunu nasıl gerçekleştirecekleri konusunda somut bir bilgiye sahip değillerdir (Korkmaz, Gür & Ersoy, 2004). Araştırmalarda, alışılmış olmayan problemlerle ve farklı çözüm süreçleri ile uğraşmanın karmaşık gerçek hayat problemleri ile baş edebilmeye fayda sağlayacağı değerlendirilmektedir (Verschaffel, Greer, Van Dooren & Mukhopadhyay, 2009). Bu çalışmada, öğretmen adaylarının eğitimlerinde alışılmış olmayan problemlerle çalıştırılmasının gerekliliğine vurgu yapılmak istenmektedir ve geleceğin öğretmenlerinin "bir problemin beş farklı çözüm yolunun iyi olduğu düşüncelerini" gerçek uygulamalara dönüştürmeleri amaçlı çalışmalar yapılması önerilmektedir..

KAYNAKLAR

- Bransford, J. & Stein, B. (1984). *The IDEAL Problem Solver: A guide for improving thinking, learning, and creativity*. New York: W.H. Freeman.
- Korkmaz, E., Gür, H. ve Ersoy, Y. (2004). Problem kurma ve çözme yaklaşımli matematik öğretimi-II: Öğretmen adaylarının alışkanlıkları ve görüşleri, *Matematikçiler Derneği Bilim Köşesi*. www.matder.org.tr.
- Narode, R., Board, J.& Davenport, L. (1993). Algorithms supplant understanding: Case studies of primary students' strategies for double-digit addition and subtraction. In J. R. Becker & B. J. Preece (Eds.), *Proceedings of the 15th Annual Meeting of the North American Chapter of The International Group for the Psychology of Mathematics Education (Vol 1, pp 254-260)*. San Jose, CA: Center for Mathematics and Computer Science Education, San Jose State University.
- Polya, G. (1973). *How to solve it*. (2nd ed). Princeton, NJ: Princeton University Press.
- Schoenfeld, A. H. (1992). Learning to think mathematically: Problem solving, metacognition, and sense-making in mathematics. In D. Grouws (Ed.), *Handbook for Research on Mathematics Teaching and Learning* (pp. 334-370). New York: MacMillan.
- Soylu, Y. & Soylu, C. (2006). Matematik derslerinde başarıya giden yolda problem çözmenin rolü. *İnönü Eğitim Fakültesi Dergisi*, 7(11), 97-111.
- Wilson, J., Fernandez, M., & Hadaway, N. (1993). *Mathematical problem solving*. Retrieved December 8, 2008, from <http://jwilson.coe.uga.edu/emt725/PSSyn/PSSyn.html>.
- Xie, X. (2004). The Cultivation of Problem-solving and Reason in NCTM and Chinese National Standards. *International Journal for Mathematics Teaching*. (October, 12th). *Electronic Journal*.
- Verschaffel, L., Greer, B., Van Dooren, W., & Mukhopadhyay, S. (2009). *Words and worlds: Modeling verbal descriptions of situations*. Rotterdam: Sense Publishers.

f -CEBİRLERİNDE SIRALI İDEALLER

ORDER IDEALS IN f -ALGEBRAS

Serap ÖZCAN
Yıldız Teknik Üniversitesi
serapozcan87@gmail.com

ÖZET: Çeşitli kaynaklardan derlenerek oluşturulan bu çalışmada, f -cebirlere genel özellikleri verilerek, f -cebirlere ideal teoriden bahsedilmiştir.

Anahtar sözcükler: f -cebiri, Riesz uzayı, ideal teori, sıralı ideal

ABSTRACT: In this study which was formed by collected several works, general properties of f -algebras were given and ideal theory of f -algebras was mentioned.

Key words: f -algebra, Riesz space, ideal theory, order ideal

GİRİŞ

L bir Riesz uzayı (vektör latisi) olsun. Her $f \in L$ için $f^+ = f \vee 0$, $f^- = -f \vee 0$ ve $|f| = f \vee (-f)$ eşitlikleri gösterilsin. Bu durumda, $f = f^+ - f^-$ ve $|f| = f^+ + f^-$ olur. $f \perp g$ (yani $|f| \wedge |g| = 0$) ise f ve g elemanlarına ayrık denir. L 'nin bir E alt kümesinin ayrık tümleyeni $E^d = \{f \in L: f \perp g, \forall g \in E\}$ ile gösterilir. I , L 'nin bir lineer alt uzayı olsun. $f \in I$ için $|g| \leq |f|$ koşulunu sağlayan $g \in I$ elemanı için I alt uzayına sıralı ideal denir. Bir sıralı ideal, Riesz alt uzayıdır. $f \in L$ tarafından üretilen sıralı temel ideal I_f ile gösterilir. $f \in P$ veya $g \in P$ iken $f \wedge g \in P$ olduğunu ifade eden, L 'deki P sıralı idealine sıralı asal ideal denir. B , L 'de sıralı ideal ve $f \in B$ olsun. Her τ için $f_\tau \in B$, $f = \sup f_\tau$ ise B 'ye bant denir. Buna göre ayrık tümleyenlerin bant olduğu söylenebilir. L 'nin Arşimedyan olması için gerek ve yeter koşul L 'deki her bandın bir ayrık tümleyen olmasıdır (Luxemburg ve Zaanen, 1971).

L 'de $v \geq 0$ elemanı verilsin. Her $\varepsilon > 0$ için, $n \geq N_\varepsilon$ koşulunu sağlayan $|f - f_n| \leq \varepsilon v$ olacak şekilde bir N_ε doğal sayısı varsa $\{f_n: n = 1, 2, \dots\}$ dizisine v -düzgün yakınsaktır denir ve $f_n \rightarrow f(v)$ ile gösterilir. $0 \leq v \in L$ için $f_n \rightarrow f(v)$ ise $\{f_n: n = 1, 2, \dots\}$ dizisi $f \in L$ 'ye düzgün yakınsar denir. Bu ise $f_n \rightarrow f$ ile gösterilecektir. v -düzgün Cauchy dizisi, düzgün Cauchy dizisiyle aynı şekilde tanımlanır. L Riesz uzayının Arşimedyan olması için gerek ve yeter koşul L 'deki her düzgün yakınsak dizinin limitinin tek olmasıdır. Eğer $\{f_n: n = 1, 2, \dots\}$ dizisi, L Arşimedyan Riesz uzayında v -düzgün Cauchy dizisi ve $f_n \rightarrow f(w)$ ise $f_n \rightarrow f(v)$ olur. L 'deki her v -düzgün Cauchy dizisi tek bir limite sahipse L Riesz uzayına v -düzgün tamdır denir. Her $0 \leq v \in L$ için L v -düzgün tam olduğunda L 'ye düzgün tam denir. Düzgün tamlığın bu tanımından, düzgün tam Riesz uzayının Arşimedyan olduğu söylenebilir.

$D \subset L$ olsun. Her $f \in L$ için $f_n \rightarrow f$ olmak üzere $f_n \in D$ ($n = 1, 2, \dots$) koşulunu sağlayan D 'nin sözde-kapanışı D' tanımlansın. $D = D'$ olduğunda L 'nin D alt kümesine düzgün kapalıdır denir. Düzgün kapalı kümeler L 'deki bir topoloji için kapalı kümelerdir. Dolayısıyla bu kümelere düzgün topoloji de denir. L 'nin bir D alt kümesinin bu topolojideki kapanışı, D^- ile gösterilir. Eğer I , L 'de bir sıralı ideal ise I^- de bir sıralı idealdir (Luxemburg ve Zaanen, 1971).

$L = \{u\}^d + \{v\}^d$ olduğunu ifade eden $u \wedge v = 0$ ise L Riesz uzayına normaldir denir. Aşağıdaki iddialar birbirine denktir:

- i) $\forall f \in L$ için $L = \{f^+\}^d + \{f^-\}^d$.
- ii) $\forall 0 \leq u_1, u_2, \dots, u_n$ ve her $n \in N$ için $\{u_1 \wedge u_2 \wedge \dots \wedge u_n\}^d = \{u_1\}^d + \{u_2\}^d + \dots + \{u_n\}^d$.
- iii) Eğer $n \in N$ ve $u_1 \wedge u_2 \wedge \dots \wedge u_n = 0$ ise $L = \{u_1\}^d + \{u_2\}^d + \dots + \{u_n\}^d$.

A bir Riesz cebiri olsun. $0 \leq w \in A$ olduğunda $u \wedge v = 0$ olduğunu belirten $(uw) \wedge v = (wu) \wedge v = 0$ sağlanıyorsa A 'ya f -cebiri denir (Birkhoff ve Pierce, 1956). Her Arşimedyan f -cebiri değişmelidir. f -cebirlere bazı temel özelliklerini verelim.

- i) Pozitif elemanların çarpımı, Riesz homomorfizmasıdır. Yani, $0 \leq u \in A$ ve $f, g \in A$ için $u(f \wedge g) = (uf) \wedge (ug)$, $u(f \vee g) = (uf) \vee (ug)$, $(f \wedge g)u = (fu) \wedge (gu)$ ve $(f \vee g)u = (fu) \vee (gu)$.
- ii) Her $f, g \in A$ için $|fg| = |f| \cdot |g|$.
- iii) $f \perp g$ ifadesi $fg = 0$ olmasını gerektirir.

iv) Her $f \in A$ için $ff^+ \geq 0$ ve $f^2 \geq 0$ dir.

A 'da bir r -ideali olan I 'ya cebir ideali denir. $f_1, f_2, \dots, f_n \in A$ tarafından üretilen r -ideali (f_1, f_2, \dots, f_n) şeklinde gösterilir. A 'da aynı zamanda sıralı bir ideal olan r -idealine, l -ideali denir.

L , bir Arşimedyan Riesz uzayı ve π , L üzerinde sıralı sınırlı bir lineer dönüşüm olsun. L 'de $f \perp g$ iken $\pi f \perp g$ oluyorsa π 'ye ortomorfizma denir (L 'deki her B bandı için $\pi(B) \subset B$ dir). L 'deki tüm ortomorfizmaların $Orth(L)$ kümesi her $u \geq 0$ için $(\pi_1 \vee \pi_2)u = (\pi_1 u) \vee (\pi_2 u)$ ve $(\pi_1 \wedge \pi_2)u = (\pi_1 u) \wedge (\pi_2 u)$ eşitlikleri ile bir Arşimedyan Riesz uzayıdır (Luxemburg, 1979). Ayrıca $Orth(L)$ birim elemanlı Arşimedyan f -cebiridir. Her ortomorfizma sıralı süreklidir ve çekirdeği bir banttır (Luxemburg, 1979). L düzgün tam olduğunda, $Orth(L)$ de düzgün tamdır.

A bir Arşimedyan f -ceberi ve $f \in A$ olsun. Her $g \in A$ için $\pi_f, \pi_f g = fg$ şeklinde tanımlanan ortomorfizmayı gösterebiliriz. $f \rightarrow \pi_f$ dönüşümü, $Orth(A)$ 'da r -ideali ve Riesz alt uzayı olan $\hat{A} = \{\pi_f : f \in A\}$ kümesi üzerinde Riesz ve cebir homomorfizmasıdır. $f \rightarrow \pi_f$ dönüşümünün birebir olması için gerek ve yeter koşul A 'nın yarı asal olmasıdır. Bu durumda A ve \hat{A} , izomorfik f -cebiridir (Bigard, Keimel ve Wolfenstein, 1977). Sonuç olarak A 'nın birimsel olması için gerek ve yeter koşul $\hat{A} = Orth(A)$ olmasıdır.

Bundan sonraki bölümlerde verilen iddiaların Huijsmans ve Pagter (1982)'in çalışmalarında bulunduğunu belirtelim.

f -CEBİRLERİNİN TEMEL ÖZELLİKLERİ

Önerme 1: A bir Arşimedyan f -ceberi olsun. Bu durumda,

- i) $\forall r, f \in A$ için $rf \in I_f$
- ii) Her düzgün kapalı sıralı ideal, l -idealidir.

Önerme 2: e birim elemanlı bir A Arşimedyan f -cebirinde aşağıdakiler sağlanır:

- i) $\forall 0 \leq u \in A$ için $u \wedge ne \uparrow u(u^2)$.
- ii) $\forall f \in A$ için $I_f = I_{f^2}$.
- iii) A yarı asaldır.

Yardımcı Özellik 3: A , e birim elemanlı bir Arşimedyan f -ceberi ve $0 \leq u \in A$ olsun. Bu takdirde her $m \geq n$ için $0 \leq u \wedge me - u \wedge ne \leq n^{-1}(u \wedge me)(u \wedge ne)$ dir.

İspat: $u_n = u \wedge ne$ ($n = 1, 2, \dots$) alalım. $m \geq n$ için $(u_m - u_n) \wedge (ne - u_n) = 0$ dir. İkinci eleman $n^{-1}u_m$ ile çarpılarak, $(u_n - u_m) \wedge (u_m - n^{-1}u_m u_n) = 0$ bulunur. Böylece, $u_m = u_n \vee (n^{-1}u_m u_n)$ olur. Buradan da $u_m - u_n = (n^{-1}u_m u_n - u_n)^+ \leq n^{-1}u_m u_n$ elde edilir.

Henriksen ve Johnson (1961), e birim elemanlı e -düzgün tam bir Arşimedyan f -cebirinde, her $u \geq e$ 'nin bir tersinin bulunduğunu ve her $u \geq 0$ 'ın bir karekökünün var olduğunu göstermek suretiyle yukarıdaki özelliği ispatlamışlardır.

Teorem 4: A , e birim elemanlı e -düzgün tam bir Arşimedyan f -ceberi olsun. Eğer $0 \leq v \leq u$ ise ve A 'da v^{-1} mevcutsa, bu durumda A 'da u^{-1} de mevcuttur.

İspat: $v = e$ olduğunu varsayalım.

1. $\alpha > 1$ için $e \leq u \leq \alpha e$ olduğunu düşünelim. $0 \leq e - \alpha^{-1}u \leq (1 - \alpha^{-1})e$ olduğundan, $\sum_{n=0}^{\infty} (e - \alpha^{-1}u)^n$ serisi e -düzgün yakınsar ve toplamı αu^{-1} dir. Dolayısıyla u^{-1} mevcuttur.

2. $e \leq u$ olduğunu düşünelim ve $u_n = u \wedge ne$ ($n = 1, 2, \dots$) alalım. 1. Durum'dan her n için u_n^{-1} mevcuttur. Yardımcı Özellik 3'den her $m \geq n$ için

$0 \leq u_n^{-1} - u_m^{-1} = u_n^{-1} u_m^{-1} (u_m - u_n) \leq u_n^{-1} u_m^{-1} (n^{-1} u_n u_m) = n^{-1} e$ elde edilir. Dolayısıyla, $\{u_n^{-1} : n = 1, 2, \dots\}$ dizisi e -düzgün Cauchy dizisidir. Hipotezden $u_n^{-1} \rightarrow w(e)$ olacak şekilde $0 \leq w \in A$ vardır. $0 \leq u_n \uparrow u(u^2)$ olduğundan $w = u^{-1}$ elde edilir.

Önerme 5: A , e birim elemanlı e -düzgün tam bir Arşimedyan f -ceberi olsun. Eğer $0 \leq u \in A$ ise bu durumda $0 \leq v \leq u$ olacak şekilde $u = vw$ eşitliği vardır ve A 'da w^{-1} mevcuttur (Gillman ve Henriksen, 1956).

İspat: Herhangi bir f -cebirinde $fg = (f \wedge g)(f \vee g)$ olduğunu göz önüne alalım. $f + g = f \vee g + f \wedge g$ formülü kullanılarak $fg - (f \wedge g)(f \vee g) = fg - (f \wedge g)(f + g - f \wedge g) = (f - f \wedge g)(g - f \wedge g) = 0$

elde edilir. $fg = (f \wedge g)(f \vee g)$ eşitliği kullanılarak, $u = (u \wedge e)(u \vee e)$ elde edilir. Dolayısıyla, $v = (u \wedge e)$, $w = (u \vee e)$ alınabilir.

Teorem 6: e birim elemanlı bir A Arşimedyan f -cebiri için gerek ve yeter koşul A 'nın e -düzgün tam olmasıdır (Gillman ve Henriksen, 1956).

İspat: Düzgün tamlığın, e -düzgün tamlığı sağladığı açıktır. Tersinin ispatı için $\{f_n: n = 1, 2, \dots\}$ A 'da bir u -düzgün Cauchy dizisi olsun. Önerme 5'den $0 \leq v \leq u$ olacak şekilde $u = vw$ eşitliğinin olduğunu ve A 'da w^{-1} in mevcut olduğunu biliyoruz. $\{g_n = w^{-1}f_n: n = 1, 2, \dots\}$ dizisi A 'da v -düzgün ve dolayısıyla da e -düzgün Cauchy dizisidir. Hipotezden $g_n \rightarrow g(e)$ olacak şekilde $g \in A$ vardır. O halde $f_n \rightarrow wg(w)$ olur ve $\{f_n: n = 1, 2, \dots\}$ olduğundan u -düzgün Cauchy dizisidir. Bu ise $f_n \rightarrow wg(u)$ olduğunu gösterir.

Yardımcı Özellik 7: A bir yarı asal Arşimedyan f -cebiri olsun. Eğer $0 \leq u, v \in A$ ise $u \leq v \Leftrightarrow u^2 \leq v^2$ dir.

İspat: Önerme 5'in ispatındaki $fg = (f \wedge g)(f \vee g)$ alınarak, $uv = (u \wedge v)(u \vee v) = \{u(u \vee v)\} \wedge \{v(u \vee v)\} = (u^2 \vee uv) \wedge (uv \vee v^2) = (u^2 \wedge v^2) \vee (uv)$ elde edilir. Böylece, $0 \leq u, v \in A$ için $u^2 \wedge v^2 \leq uv$ olur. $u^2 \leq v^2$ olsun ve $u \leq v$ nin sağlanmadığını, yani $u \wedge v < u$ olduğunu varsayalım. Bu, $(u \wedge v)^2 < u^2$ olduğunu ifade eder. Dolayısıyla, $u^2 = u^2 \wedge v^2 = u^2 \wedge v^2 \wedge (uv) = (u \wedge v)^2 < u^2$ olur ki, bu ise bir çelişkidir. O halde, $u^2 \leq v^2$ ise $u \leq v$ dir. $u \leq v$ iken $u^2 \leq v^2$ olduğu ise kolayca görülür.

Teorem 8: A, e birim elemanlı düzgün tam bir f -cebiri olsun. Her $0 \leq u \in A$ için $v^2 = u$ olacak şekilde bir tek $0 \leq v \in A$ vardır ($v = \sqrt{u} = u^{1/2}$).

Aşağıdaki Teorem Henriksen'in "(*) Özelliği"nin birimli olan her düzgün tam f -cebirinde sağlandığını gösterir.

Teorem 9: A, e birim elemanlı düzgün tam bir f -cebiri olsun. Eğer $0 \leq v \in A$ için $0 \leq u \leq v^2$ ise $0 \leq w \leq v$ ve $u = vw$ olacak şekilde bir tek $0 \leq w \in A$ vardır (Bu özellik (*) Özelliği olarak adlandırılır.).

İspat: $n = 1, 2, \dots$ için $w_n = (v + n^{-1}e)^{-1}$ olsun. $\{w_n: n = 1, 2, \dots\}$ bir e -düzgün Cauchy dizisidir. O halde $w_n \rightarrow w(e)$ olacak şekilde $0 \leq w \in A$ vardır. $v + n^{-1}e \rightarrow v(e)$ olduğundan $w_n(v + n^{-1}e) \rightarrow vw$ olur. Ancak her n için $w_n(v + n^{-1}e) = u$ olduğundan $u = vw$ olur. Her n için $w_n \leq v$ olduğundan, $w \leq v$ elde edilir. Şimdi w 'nin tek olduğunu gösterelim. $0 \leq w' \leq v$ ve $u = w'v$ olduğunu varsayalım. A yarı asal olduğundan $w - w' \perp v$ dir. Ayrıca $w - w' \in I_v$ dir. Dolayısıyla, $w = w'$ olur.

Sonuç 10: A, e birim elemanlı düzgün tam bir f -cebiri olsun.

- i) Eğer $0 \leq u \leq v$ ise $u^2 = uv$ olacak şekilde bir tek $0 \leq w \leq v$ vardır.
- ii) Eğer $0 \leq v \in A$ ve $n \in N$ için $0 \leq u \leq v^{1+2^{-n}}$ ise $u = vw$ olacak şekilde $0 \leq w \in A$ vardır.
- iii) Eğer $f \in A$ için $0 \leq u \leq v^2$ ise $|t| \leq |f|$ ve $u = tf$ koşullarını sağlayan bir tek $t \in A$ vardır.

Önerme 11: A , yarı asal bir Arşimedyan f -cebiri olsun. Aşağıdaki koşullar verilsin.

- i) (*) Özelliği
 - ii) $\hat{A} = \{\pi_f: f \in A\}$, $Orth(A)$ 'da bir l -idealdir.
- i) \Leftrightarrow ii) gerçektir. Ayrıca A aynı zamanda düzgün tam ise i) \Leftrightarrow ii) dir.

f -CEBİRLERİNDE İDEAL TEORİ

I ve J r -idealleri olmak üzere, $IJ = \{\sum_{k=1}^n r_k s_k: r_k \in I, s_k \in J, n \in N\}$, I ve J 'nin üretecini gösterebilirsin.

Tanım 12: I, A f -cebirinde bir r -ideali olsun.

- i) $I = \sqrt{I} = \{f \in A: n \in N \text{ için } f^n \in I\}$ ise I yarı asaldir.
- ii) $I = I^2$ ise I idempotenttir.
- iii) $f \in I$ veya $g \in I$ olmak üzere $fg = 0$ ise I sözde asaldir.
- iv) Her $f \in I$ için $|f| = g^2$ olacak şekilde $g \in I$ varsa I karekök kapalıdır.

Aşağıdaki önerme Subramanian (1967) tarafından ispat edilmiştir.

Önerme 13: A bir Arşimedyan f -cebiri olsun.

- i) Eğer I, A 'da bir l -ideali ise, \sqrt{I} da bir l -idealdir.
- ii) Eğer P, A 'da bir l -ideali ise P 'nin bir asal r -ideali olması için gerek ve yeter koşul P 'nin sözde asal ve yarı asal olmasıdır.

Önerme 14: A bir yarı asal Arşimedyan f -cebiri olsun.

- i) Eğer I, A 'da karekök kapalı r -ideali ise $I = I^2$ ve $I = \sqrt{I}$ dir.
ii) A 'da her idempotent l -ideali yarı asaldir.

Teorem 15: Her yarı asal r -ideali, bir l -idealidir.

İspat: Daha önce de gösterildiği gibi $f \in \sqrt{I} \Leftrightarrow |f| \in \sqrt{I}$ olduğunu biliyoruz. $0 \leq u \leq v$ ve $v \in \sqrt{I}$ olduğunda $u \in \sqrt{I}$ olduğu gösterilmelidir. $Orth(A)$, birim elemanlı düzgün tam bir f -cebiri olduğundan, $0 \leq \pi_u \leq \pi_v$ ve Sonuç 10 i)'den, $\pi \in Orth(A)$ ve $0 \leq \pi \leq \pi_v$ için $\pi_u^2 = \pi \pi_v$ dir. Bu özellik bir kez daha uygulanarak $0 \leq \pi_1 \in Orth(A)$ olacak şekilde $\pi^2 = \pi_1 \pi_v$ bulunur. Buradan, $\pi_u^4 = (\pi_1 \pi_v) \pi_v^2 = \pi_{\pi_1 v} \pi_v^2$ ve dolayısıyla $u^4 = (\pi_1 v) v^2$ elde edilir. Böylece, $u \in \sqrt{I}$ elde edilir.

Teorem 16: Düzgün tam olan bir yarı asal A f -cebirinde,

- i) Her idempotent r -ideali bir l -idealidir.
ii) Her idempotent r -ideali yarı asaldir.

İspat:

i) I 'nin A 'da $I = I^2$ koşulunu sağlayan bir r -ideali olduğunu varsayalım. $\hat{I} = \{\pi_f : f \in I\}$ alalım. O halde \hat{I}, \hat{A} 'da bir r -idealidir. İlk olarak \hat{I} 'nin $Orth(A)$ 'da bir l -ideali olduğunu gösterelim. $\pi \in Orth(A)$ ve $\pi_f \in \hat{I}$ olsun. Hipotezden $f = \sum_{k=1}^n r_k s_k$, $r_k, s_k \in I$ ($k = 1, 2, \dots, n$) olur.

\hat{I}, \hat{A} 'da bir r -ideali olduğundan $\pi \pi_f = \pi(\sum_{k=1}^n \pi_{r_k} \pi_{s_k}) = \sum_{k=1}^n (\pi \pi_{r_k}) \pi_{s_k} = \sum_{k=1}^n \pi_{\pi r_k} \pi_{s_k} \in \hat{I}$ elde edilir. \hat{I} 'nin $Orth(A)$ 'da bir l -ideali olduğu gösterilmelidir. $f \in I, \pi \in Orth(A)$ ve $0 \leq \pi \leq |\pi_f|$ alalım. $k = 1, 2, \dots, n$ için $f = \sum_{k=1}^n r_k s_k$, $r_k, s_k \in I, I = I^2$ olduğundan, $0 \leq \pi \leq |\pi_f| = \pi_{|f|} \leq \sum_{k=1}^n |\pi_{r_k} \pi_{s_k}| \leq \sum_{k=1}^n (\pi_{r_k}^2 + \pi_{s_k}^2)$ olur. Riesz ayrıştırma özelliği kullanılarak $0 \leq \rho_k \leq \pi_{r_k}^2$ ve $0 \leq \sigma_k \leq \pi_{s_k}^2$ ($k = 1, 2, \dots, n$) koşullarını sağlayan $\rho_k, \sigma_k \in Orth(A)$ için $\pi = \sum_{k=1}^n (\rho_k + \sigma_k)$ bulunur. $\hat{I}, Orth(A)$ 'da bir l -ideali olduğundan, $\rho_k, \sigma_k \in \hat{I}, (k = 1, 2, \dots, n)$ sonucuna varırız.

ii) i)'den ve Önerme 14'den kolayca görülür.

Teorem 17: Eğer I ve $J, (*)$ Özelliği olan A Arşimedyan f -cebirinde l -ideali iseler, IJ de l -idealidir. Gerçekten $IJ = \{f \in A : |f| \leq uv, 0 \leq u \in I, 0 \leq v \in J\}$ dir.

İspat: $u \in IJ$ olduğunu göstermek için $f \in IJ$ olmak üzere $0 \leq u \leq |f|$ olduğunu göstermek yeterlidir. $f \in IJ$ olduğundan $0 \leq p \in I, 0 \leq q \in J$ olacak şekilde $|f| \leq pq$ vardır. Dolayısıyla, $0 \leq u \leq (p+q)^2$ olur. $(*)$ Özelliği, $0 \leq w \in A$ için $u = w(p+q)$ olduğunu ifade eder. Eğer, $w_1 = w \wedge q$ ve $w_2 = w \wedge p$ alınırsa, $w_1 \in J, w_2 \in I$ ve $w_1 p + w_2 q = w p \wedge p q + w q \wedge p q = w p + w q = u$ elde edilir. Dolayısıyla $u \in IJ$ olur.

KAYNAKLAR

- Bigard, A., Keimel, K. ve Wolfenstein, S., (1977). Groupes at anneaux reticules. *Lecture Notes In Math.*, 608. Springer-Verlag, Berlin, Heidelberg, New York.
- Birkhoff, G. ve Pierce, R. S., (1956). Lattice ordered rings. *An. Acad. Brasil. Cienc.*, 28, s.41-69.
- Gillman, L. ve Henriksen, M., (1956). Rings of continuous functions in which every finitely generated ideal is principal. *Transactions of The American Mathematical Society*, 82, s.366-391.
- Henriksen, M. ve Johnson, D. G., (1961), On the structure of a class of Archimedean lattice-ordered algebras. *Fund. Math.*, 50, s.73-94.
- Huijsmans, C. B. ve Pagter, B. de, (1982). Ideal theory in f -algebras. *Transactions of The American Mathematical Society*, 269, no.1.
- Luxemburg, W. A. J., (1979). Some aspects of the theory of Riesz spaces. *Univ. Arkansas Lecture Notes In Math.*, 4.
- Luxemburg, W. A. J. ve Zaanen, A. C., (1971). *Riesz spaces I*. North Holland, Amsterdam, London.
- Subramanian, H., (1967). l -prime ideals in f -rings. *Bull. Soc. Math. France*, 95, s.193-203.

THE PERCEPTIONS OF THE PRE-SERVICE SCIENCE TEACHERS' PROBLEM-SOLVING SKILLS

Asiye BAHTIYA

Bilge CAN

Developments in knowledge, science and technology cause some problems for individuals to adapt to new situations. For this reason, improving problem solving skills of individuals to cope with those problems became one of the most important objectives of education. Teachers should help students not only by just giving information how to solve a problem but also by assimilating this skill. Undoubtedly, firstly they should have problem solving skills to be able to help their students. In this context, the aim of the study is to find out the perceptions of pre-service science teachers' problem-solving skills. The sample of the study was consisted of 76 freshmen, 81 sophomore, 117 junior and 69 senior in total 343 pre-service science teachers who study in Department of Science Teacher Education in 2012-2013 academic year. Problem solving inventory (PSI) which was developed by Heppner and Petersen (1982) and adapted into Turkish by Şahin, Şahin and Heppner (1993) was used as a data collection tool. Data obtained in the study was analysed with SPSS (version 16.0). In the data analysis process; beside descriptive statistical methods, One Way ANOVA was used to determine whether or not there is any significant difference among grades and their points of all the PSI and its dimensions. According to the results of analysis, a significant difference was found between sophomores and juniors and also between sophomores and seniors. Moreover, when data was examined according to "impulsive style" dimension and "avoidant style" dimension; it was also found that there was a significant difference among grades.

Keywords: Problem Solving Skills, Pre-service Science Teacher

7. SINIF “İNSAN VE ÇEVRE” ÜNİTESİNE YÖNELİK BİR EĞİTSEL OYUN GELİŞTİRİLMESİ ve UYGULANABİLİRLİĞİNİN ARAŞTIRILMASI

DEVELOPMENT OF AN EDUCATIONAL GAME AND EXAMINATION OF ITS APPLICABILITY

Lale Cerrah ÖZSEVGEÇ
Karadeniz Teknik Üniversitesi
cerrah@ktu.edu.tr

Ayşe TAYFUR
İstanbul Üsküdar Gazi Mustafa Altunbaş Ortaokulu
Ayse_tayfur@hotmail.com

Arzu ERDOĞAN
Kömürcüler Ortaokulu
yagmur_arzu84@hotmail.com

Burçin TURAN
Karadeniz Teknik Üniversitesi
burcinturan09@gmail.com

Nur KURTULUŞ
Kafkas Üniversitesi
nurkurtulus@hotmail.com

Rabia Gamze YAYLA
Cumhuriyet Üniversitesi
gamze_yyl@hotmail.com

ÖZET: Bu araştırmada, 7. Sınıf ‘İnsan ve Çevre’ Ünitesine yönelik bir eğitsel oyun geliştirilmiş ve uygulamadaki etkililiğine bakılmıştır. Geliştirilen eğitsel oyunun etkililiğinin araştırılması amaçlandığı için basit deneysel desen kullanılmıştır. Çalışma Trabzon İl’ine bağlı bir köy okulunun 7. sınıf öğrencileri (N=29) ile yürütülmüştür. Çalışmada, çoktan seçmeli bir test ve yarı yapılandırılmış mülakat kullanılmıştır. Çok aşamalı olarak geliştirilen eğitsel oyun “eşleştirme, besin zinciri oluşturma, ekosistem tamamlama, riziko ve videodaki çevre sorununun belirleme” aşamaları içermektedir. Öğrencilerin testin ön ve son uygulamalarından aldıkları puanlar SPSS (16.0) programı ile analiz edilmiştir. Verilerin istatistiksel analizine göre, öğrencilerin ön ve son test puanları arasında son test lehine anlamlı bir fark bulunmuştur. Öğrencilerle yürütülen mülakatlarda ise sürecin eğlendirici ve öğretici olduğu tespit edilmiştir. Elde edilen bulgular doğrultusunda, ‘İnsan ve Çevre’ ünitesi için geliştirilen eğitsel oyunun uygulanabilir olduğu sonucuna varılmıştır.

Anahtar sözcükler: eğitsel oyun, çevre eğitimi, ilköğretim, öğrenci başarısı

ABSTRACT: In this study, an educational game was developed for the concepts of the “Human and Environment” unit in 7th class program and its applicability was examined. Simple experimental design was used. Study was conducted with 7th grade students (N= 29) in a village school in Trabzon province. Semi-structured interview and multiple-choice test were used to collect the data. Educational game has five stages named as "pairing, composition of food chain, completion of the ecosystem, risk and determining environmental problems in the video" stages. The data obtained from pre and post test were analyzed with SPSS (16.0) program. According to the statistical analysis of the data, a significant difference was found in favor of the post test between pre and post test scores of students. The result of the study showed that the educational game is applicable and effective for the “Human and Environment” Unit.

Key words: educational games, environmental education, primary education, success of students

GİRİŞ

Artan nüfus ve gelişen teknoloji ile birlikte meydana gelen çarpık kentleşme, ormansızlaşma, ozon tabakasının incilmesi, sera etkisi ve beraberinde küresel ısınma bugün sıkça adını duyduğumuz çevre sorunlarından bazılarıdır. Bu durum bize çevre sorunlarının artık küresel bir boyut kazandığını ve tedbir almazsak yaşam

kalitemizi düşürecek çok büyük problemlerle karşılaşabileceğimizi göstermektedir (Tombul, 2006; Selvi ve Yıldız, 2009).

Mevcut çevre sorunlarının üstesinden gelebilecek ve oluşabilecek yeni çevre sorunlarına engel olabilecek, çevre sorunlarının oluşmasındaki temel etkenlerden biri olan yine insanoğlunun kendisidir. Çözümüne götürecektir ise çevreyi korumayı davranış haline dönüştürebilecek bir çevre eğitiminin kazandırılmasıdır (Ünal ve Dımışkı,1999). Fakat çevre eğitimi ile ilgili çalışmalar incelendiğinde, ilköğretimden yüksek öğretime kadar öğrencilerin çevre ile ilgili kavramları yeterince bilmedikleri, çevre eğitiminin uzak ve genel hedeflerine istenilen düzeyde ulaşamadığı söylenebilir (örn. Şahin vd., 2004.; Pekel, Kaya ve Demir, 2007; Erdoğan, 2011, Artun, 2013). Bu duruma neden olan etkenlerden birinin, çevre ile ilgili konuların öğretilmesi için seçilen yöntem ve tekniklerin olduğu düşünülmektedir. Fen ve Teknoloji dersi kapsamında yer alan çevre konularının öğretilmesinde sıklıkla öğretmen merkezli, öğrencilerin konuya ilgisini çekemeyen ve öğrencileri ezberle yönelten tekniklerin kullanıldığı dikkat çekmektedir (Yılmaz, 2006; Erdoğan, 2011; Gerehan, 2011). İlköğretim 7. Sınıf Fen ve Teknoloji Öğrenci Ders Kitabı incelendiğinde, çevre konularına çok yüzeysel olarak değinildiği ve bu konularla ilgili öğrencileri aktif hale getirebilecek etkinliklerin yok denecek kadar az olduğu dikkat çekmektedir (Erdoğan, 2012; Artun, 2013). “Ağaç yaş iken eğilir” atasözü dikkate alındığında, ilköğretim düzeyinde verilecek çevre eğitiminin sonraki öğretim kademeleri için çok önemli olduğu unutulmamalıdır.

İlköğretim 7. sınıf öğrencileri 12 ve 14 yaş aralığında olabilmektedirler. Bu yaş aralığındaki çocuklar ya somut işlemler döneminde ya da soyut işlemler dönemine geçiş durumundadırlar (Slavin, 1991). Bu nedenle, öğretmenlerin öğretim sürecini planlarken ya da kullanacakları öğretim materyallerini seçerken soyut düşünen öğrencilerin yanı sıra hala somut işlemler dönemindeki öğrencileri de dikkate alması önem taşımaktadır. Bu bağlamda, öğrencilerin anlamakta zorlandıkları soyut fen kavramlarının ezberlenmeden öğretilmesi için aktif öğrenme etkinlikleri kullanılarak konuların somutlaştırılması önerilmektedir (örn; Demir, 2012; Karamustafaoğlu ve Kaya, 2013). İlköğretim düzeyinde, öğrenciyi aktif olarak derse katabilecek ve onu sıkılmayacak öğretim etkinliklerinden birinin eğitsel oyunlar olduğu söylenebilir. Oyun genel anlamda, amaçlı ya da amaçsız, kurallı veya kuralsız oynanan, çocuğun her zaman isteyerek ve zevk alarak katıldığı; her yönden bireysel gelişimi temel alan, hayatımızın her döneminde olabilen ve etkili bir öğrenme süreci olarak tanımlanabilir (Dönmez, 1992, Aktaran: Kaya, 2013). Eğitsel oyunların öğretimde kullanılmasının temelinde, konunun öğrencinin bildiği ya da bilmediği oyun formatlarını kullanarak öğretilmeye çalışılması yatmaktadır (Demirel, Seferoğlu, ve Yağcı, 2003). Oyun içerisinde eğlence ve yarışma unsurları olduğu için, farklı yaş gruplarında da olsalar herhangi bir öğretim kademesindeki öğrenci oynamaktan sıkılmayacaktır (Aykaç, 2009). İlköğretim öğrencilerinin dikkat sürelerinin az olduğu dikkate alındığında, özellikle ilköğretim öğrencileri için oyun yolu ile öğretimin oldukça etkili olabileceği söylenebilir (Demir, 2012). Dersin içeriğine uygun olarak hazırlanan oyunların soyut kavramları somutlaştırarak öğrenciler için eğlenceli ve kolay anlaşılır hale getirilebileceği belirtilmektedir (Şaşmaz Ören ve Erduran Avcı, 2004).

Bütün bu bilgiler ışığında bu çalışmada, “İnsan ve Çevre” ünitesine yönelik bir eğitsel oyun geliştirilmiş ve uygulanabilirliği araştırılmıştır. Elde edilecek bulguların ışığında, öğretmenlere kullanabilecekleri bir materyal sunulması ve etkililiğinin ortaya konması açısından literatüre önemli bir katkı sağlayacağı düşünülmektedir.

YÖNTEM

Bu araştırmada, 7. Sınıf ‘İnsan ve Çevre’ Ünitesine yönelik bir eğitsel oyun geliştirilmiş ve uygulamadaki etkililiğine bakılmıştır. Geliştirilen eğitsel oyunun etkililiğinin araştırılması amaçlandığı için basit deneysel desen kullanılmıştır. Çalışma Trabzon İl’ine bağlı bir köy okulunun 7. Sınıf öğrencileri (N=29) ile yürütülmüştür. Çalışmada, çoktan seçmeli bir test ve yarı yapılandırılmış mülakat kullanılmıştır. Eğitsel oyunun etkililiğini tespit etmek için kullanılan test, literatürden faydalanılarak geliştirilmiş ve 28 adet çoktan seçmeli soru içermektedir. Başarı testinin güvenilirliği 0,74 olarak hesaplanmıştır. Test, uygulama öncesinde ve sonrasında, ön ve son test olarak iki kez kullanılmıştır. Öğrencilere testi cevaplamaları için 45 dakika süre verilmiştir. Yanlışlar doğruyu götürmeyecek şekilde değerlendirme yapılmıştır. Testin değerlendirilmesi, boş ve yanlış cevaplara 0, doğru cevaba 1 puan verilerek toplam 28 puan üzerinden yapılmıştır. Ders bitiminde üç öğrenci ile bireysel mülakatlar yürütülmüştür.

Öncelikle, “İnsan ve Çevre” ünitesinin kazanımlarından oluşan bir belirtke tablosu hazırlanmış ve hazırlanan belirtke tablosu doğrultusunda oyunun aşamaları geliştirilmiştir. Geliştirilen eğitsel oyun biyoloji alanında uzman iki öğretim üyesi ve iki Fen ve Teknoloji öğretmenine inceletirilmiştir. Alınan görüşler doğrultusunda oyun şekillendirilmiş ve kuralları netleştirilmiştir. Tasarlanan oyunun pilot çalışması, İlköğretim 8. Sınıfta öğrenim gören 20 öğrenciyle yürütülmüş ve pilot çalışma doğrultusunda gerekli düzenlemeler yapılarak oyuna son hali verilmiştir. Geliştirilen eğitsel oyunun aşamaları Tablo 1’de sunulmuştur.

Tablo 1. İnsan ve Çevre Ünitesine Yönelik Hazırlanan Oyunun Aşamaları

Aşamalar	Kurallı	Amaç	Süre	Puanlama
----------	---------	------	------	----------

Eşleştirme	Her gruptan bir sözcü seçilir, panoya yerleştirilen zarflar içindeki resimli kavram kartları ile tanım kartlarını eşleştirmeye çalışır, yanlış olursa diğer gruptan sözcü kalkar, doğru ise aynı grup eşleştirmeye devam eder.	Kavramlarla tanım kartlarını doğru eşleştirmek.	Yok* *Eşleştirme işlemi panodaki kartlar bitene kadar devam eder.	Her doğru 50 puan, yanlışlar ise etkisizdir.
Besin Zinciri Oluşturma	Her gruptan bir sözcü seçilir ve her birine hayvan resimleri ile karton verilir. Belirlenen sürede kartonlar üzerine hayvan resimlerini yapıştırılıp aralarındaki ilişkiyi oklarla çizilerek besin zinciri oluşturulur.	Seçilen hayvanlar arasındaki ilişkilerin yönünü doğru çizmek.	2 dakika	Her doğru ok 50 puan her yanlış ok 50 puandır.
Ekosistem Tamamlama	Her gruba üzerinde ekosistemin adı yazan renkli karton ile canlı ve cansız öğeler verilir. Belirlenen sürede belirlenen ekosistemin öğelerini kartonun üzerine yerleştirir.	Seçilen ekosisteme uygun canlı ve cansız öğeleri seçmek.	2 dakika	Her doğru öge 50 puan her yanlış öge 50 puandır.
Riziko	Her gruptan bir sözcü seçilir. Her grup sırasıyla bilgisayarda hazırlanan program aracılığıyla zorluklarına göre farklı puan türlerinden oluşan soruları seçer ve sözcüler yanıtlar. Her grup her puan türünden en az 1 soru seçmelidir.	Açtırılan soruyu doğru yanıtlamak.	Her soru için 1 dakika* *sorular bitene kadar oyun devam eder.	50- 100-150-200 değerinde sorular bulunmaktadır.
Videodaki Çevre Sorununu Belirleme	4 farklı çevre sorununu içeren video her grup tarafından aynı anda izlenir. Öğrenciler grup arkadaşları ile birlikte videodaki çevre sorunlarını not eder.	Videodaki 4 çevre sorununu doğru belirlemek.	Video süresince	Bilinen her doğru çevre sorunu için 50 puan

Tablo 1’de görüldüğü gibi eğitsel oyun oynanırken sınıf 4 gruba ayrılmıştır. Oyunların bazıları gruptan bir sözcü seçilerek bireysel, bazıları ise grupça oynanmıştır. Bireysel oynanan oyunlarda sözcünün tahtaya çıkarak herkesin görebileceği şekilde oyunu oynamasına dikkat edilmiş, bu sayede tüm sınıfın kavramlar hakkında bilgi sahibi olması sağlanmıştır. Ayrıca sözcüler seçilirken farklı kişiler olmasına dikkat edilmiş ve tüm öğrenciler oyuna dahil edilmiştir. Grupların kendi içinde heterojen, sınıf içinde homojen olmasına dikkat edilmiştir. Oyun kurallarına göre puanlama yapılmış, alınan puanlar yalnızca oyun sırasında kullanılmıştır. Oyun sonunda toplam puana göre en yüksek puanı olan grup belirlenip, üyelerine hediyeleri verilmiştir. Ayrıca oyuna katılan tüm öğrencilere de teselli hediyeleri verilmiştir.

BULGULAR

“Çevre ve İnsan” ünitesine yönelik geliştirilen eğitsel oyunun etkililiğinin araştırılması için uygulanan testten elde edilen ön ve son test bulgularına ait istatistiksel analiz sonuçları Tablo 2’de sunulmuştur.

Tablo 2. Başarı Testi Öntest-Sontest Ortalama Puanlarına İlişkin Bağımlı t-testi Sonuçları

Ölçüm	N	\bar{X}	S	sd	t	p
Ön test	29	18,6207	,79471	28	2,946	,006
Son test	29	20,0345	,81471			

Tablo 2 incelendiğinde, öğrencilerin test uygulamalarından elde edilen ön ve son test puanları arasında anlamlı bir farklılık bulunmuştur ($p < .05$). Ortalama puanlar incelendiğinde son test puanının (20,0345) ön test puanından (18,6207) fazla olduğu görülmektedir. Bu bulgular doğrultusunda, geliştirilen eğitsel oyunun uygulanabilir ve etkili olduğu görülmektedir.

Test bulgularını daha derinlemesine incelemek amacıyla, öğrencilerin ön test ve son test ortalama puanlarında anlamlı farklılık olan sorular belirlenmiştir. Bu sorular ve içerikleri ile ilgili bulgular Tablo 3’te sunulmuştur.

Tablo 3. Testin Ön ve Sontest Ortalama Puanlarında Anlamlı Farklılık Olan Maddeler

	İçerik	Madde No	Ön Test	Son test
			%	%
Başarı testi	Tür	1	52	78
	Popülasyon	2	55	72
	Ekosistem	3	67	70
	Besin zinciri	10	62	71
	Su kirliliği	16	74	78
	Çevre kirliliği	19	82	90
	Hava kirliliği	22	66	86
	Su kirliliği	23	63	76
	Toprak kirliliği	25	71	80

Ön ve sontest ortalama puanları arasında anlamlı farklılık bulunan soruların içerikleri incelendiğinde, oyunun her bir aşamasındaki temel kavramlar dikkati çekmektedir. Örneğin, ‘Videodaki Çevre Sorununu Bulma’ aşamasında öğrenciler çevre kirlilikleri, türleri ve sonuçlarını tartışmışlardır. Ayrıca, oyunun ‘Ekosistem Tamamlama’ aşaması sayesinde tür, popülasyon gibi kavramları pekiştirmişlerdir. Oyun aşamalarına ait temel kavramlar ya da oyun sırasında vurgulanan kavramların son testte daha fazla yapılması, eğitsel oyunun etkili olduğu şeklinde yorumlanabilir.

Öğrenciler, oyunlar esnasında nesne ve olayların değişebilir özelliklerini de dikkate alıp yeni durumlar tasarlayarak oyunları tamamlayabilmişlerdir. Bu durum onların bu iki beceriyi kazanmalarına olumlu etki ettiği söylenebilir. Örneğin, “Besin Zinciri Oluşturma” oyununda öğrencilere birçok canlı ve cansız öge verilmesine rağmen, onlar doğru zinciri, belirledikleri doğru öğelerle oluşturabilmişlerdir.

Oyunun ‘Ekosistem Tamamlama’ aşamasında öğrencilerden farklı ekosistemleri hayal edip, verilen malzemelerle uygun şekilde bu ekosistemleri oluşturmaları beklenmiştir. Oyun süresince öğrencilerin yaratıcılıklarını kullanarak farklı ekosistemleri ortaya koyabilmeleri için teşvik edilmiş olmaları onların model oluşturma becerilerinin gelişimine olumlu etkide bulunduğu söylenebilir. Ayrıca oyunlarda görselliğe büyük önem verilmesinin de öğrencilerde bu becerinin gelişmesini olumlu yönde etkilediği düşünülebilir. Yaratıcılık duygusunu geliştirmesi, eğitsel oyun kullanımının yararlarından biri olarak belirtilmektedir (Aykaç, 2009)

Öğrencilerle yürütülen mülakatlarda, oyunların genelinde çok eğlendikleri tespit edilmiştir. Oyunların bazıları bireysel, bazıları ise grupça karar verildikten sonra bir sözcü tarafından sonucun açıklanması şeklinde tasarlanmıştır. Oyunların tamamı bütün sınıfın önünde ve tüm öğrencilerin görebilecekleri şekilde oynandığı için nerdeyse %100 katılımın sağlandığı söylenebilir. Öğrenciler sınıfta, kargaşadan uzak coşku ve keyif havasının hakim olduğunu belirtmişlerdir. Dersi yürüten fen ve teknoloji öğretmeni de başarısı düşük öğrencilerin bile katılımının iyi olduğunu ifade etmiştir.

SONUÇ

Elde edilen bulgular ışığında, geliştirilen eğitsel oyunun döngüsel olması, kavramların tekrarlanmasına olanak sağlaması açısından öğrencilerin öğrenmesi üzerinde etkili olduğu sonucuna varılabilir. Farklı çalışmalarda da benzer sonuçlar elde edilmiştir (örn. Aycan, 2002; Yurt, 2007). Öğrenciler oyun sürecinde eğlenmişlerdir. Tüm sınıfın katılımı sağlanmış, öğrencilerin ilgileri artmıştır. Bu bağlamda, geliştirilen oyunun uygulanabilir olduğu söylenebilir. İlköğretim düzeyinde özellikle soyut fen kavramlarının öğretiminde eğitsel oyun kullanımının yaygınlaştırılması ve öğretmenlerin bu konuda bilgilendirilmesi önerilmektedir.

KAYNAKLAR

- Artun, H. (2013). 7. Sınıf öğrencilerinin çevre eğitimine yönelik tasarlanan modüler öğretim programının etkililiğinin araştırılması. Yayımlanmamış Doktora Tezi, KTÜ Eğitim Bilimleri Enstitüsü, Trabzon.
- Aycan, S. (2002). *Periyodik cetvelin ve elementlerin tombala oyun tekniği ile öğretimi ve bellekte kalıcılığının saptanması*. V. Ulusal Fen Bilimleri ve Matematik Eğitimi Kongresi, Ankara
- Aykaç, N. (2009). *Öğretme ve öğrenme sürecinde aktif öğretim yöntemleri*. (2. Basım). Naturel Yayıncılık, Ankara.
- Demir, M. (2012). 7. Sınıf vücudumuzdaki sistemler ünitesinin oyun tabanlı öğrenme yaklaşımı ile işlenmesinin öğrencilerin akademik başarılarına ve fen teknoloji dersine karşı tutumlarına etkisi. X. Ulusal Fen ve Matematik Eğitimi Kongresi, Niğde Üniversitesi, Niğde
- Demirel, Ö. Seferoğlu, S. ve Yağcı, E. (2003). *Öğretim teknolojileri ve materyal geliştirme*. (4. basım), PegemA Yayıncılık, Ankara.

- Dönmez, N. (1992). *Oyun kitabı*. Esin Yayınevi, İstanbul.
- Aktaran: Kaya, S. (2013). Okul öncesi eğitimde oyun ve oyunun işlevleri. *Eğitim Dergisi*, 10(37).
- Erdoğan, A. (2011). Çevre için eğitimde alternatif öğretim etkinliklerinin öğrencilerin başarı ve tutumları üzerine etkisi. Yayımlanmamış Yüksek Lisans Tezi, KTÜ Eğitim Bilimleri Enstitüsü, Trabzon.
- Gerehan, M. (2011). Bilimsel söylemlerle desteklenmiş birleştirme 1 tekniğinin öğrencilerin çevre konularındaki öğrenmeleri üzerine etkisi. Yayımlanmamış Yüksek Lisans Tezi, KTÜ Eğitim Bilimleri Enstitüsü, Trabzon.
- Karamustafaoğlu, O. ve Kaya, M. (2013). Eğitsel oyunlarla ‘yansıma ve aynalar’ konusunun öğretimi: yansımali koşu örneği. *Araştırma Temelli Etkinlik Dergisi (ATED)*, 3(2), 41-49.
- Pekel, F., O., Kaya, E., ve Demir, Y. (2007). Farklı lise öğrencilerinin ozon tabakasına ilişkin düşüncelerinin karşılaştırılması. *Kastamonu Eğitim Dergisi*, 15(1), 169-174.
- Selvi, M., ve Yıldız, K. (2009). Biyoloji öğretmeni adaylarının sera etkisi ile ilgili algılamaları. *Türk Eğitim Bilimleri Dergisi*, 7(4), 813-852.
- Slavin, E.R. (1991). *Eudcational psychology, theory into practice*. Prentice-Hall International, Inc., Third Edition.
- Şahin, N.F., Cerrah, L., Saka, A., ve Şahin., B. (2004). Yüksek öğretimde öğrenci merkezli çevre eğitimi dersine yönelik bir uygulama. *Gazi Üniversitesi Eğitim Fakültesi Dergisi*, 24(3), 113-128.
- Şaşmaz Ören, F. ve Erduran Avcı, D. (2004). Eğitimsel oyunla öğretimin fen bilgisi dersi “güneş sistemi ve gezegenler” konusunda akademik başarı üzerine etkisi. *Ondokuz Mayıs Üniversitesi Eğitim Fakültesi Dergisi*, 18, 67-76.
- Tombul, F. (2006). Türkiye’de çevre için eğitime verilen önem. Yayımlanmamış, Yüksek Lisans Tezi, Ankara Üniversitesi, Sosyal Bilimler Enstitüsü, Ankara.
- Ünal, S. ve Dimişki E. (1999). UNESCO-UNEP Himayesinde çevre eğitiminin gelişimi ve Türkiye’de ortaöğretim çevre eğitimi. *Hacettepe Üniversitesi Eğitim Fakültesi Dergisi*, 16(17), 142-154.
- Yılmaz, D. (2006). İlköğretimde çevre eğitimi için yöntem geliştirme. Yayımlanmamış Yüksek Lisans Tezi, Marmara Üniversitesi, Fen Bilimleri Enstitüsü, İstanbul.
- Yurt E. (2007). Eğitsel oyun tekniği ile fen öğretimi ve yeni ilköğretim müfredatındaki yeri ve önemi (Muğla İli Merkez ilçe örneği). Muğla Üniversitesi Fen Bilimleri Enstitüsü, Muğla.

ÖĞRETMEN ADAYLARININ KAVRAM KARİKATÜRLERİNE İLİŞKİN GÖRÜŞLERİ

PROSPECTIVE TEACHERS' VIEWS ON CONCEPT CARTOONS

Hülya DEMİRCİOĞLU
KTÜ Fatih Eğitim Fakültesi
hulyadem76@hotmail.com

Lale CERRAH ÖZSEVGEÇ
KTÜ Fatih Eğitim Fakültesi
cerrah@ktu.edu.tr

Ayşe ÖZTÜRK
Yüksek Lisans Öğrencisi

ÖZET: Etkili ve kalıcı bir öğrenme için fen öğreniminde öğrencilerin ön bilgilerine önem veren ve onları aktif hale getiren öğrenme araçlarının kullanılması gerekmektedir. Öğrencilerin günlük yaşamdaki problemlerini çözmelerine ve derslere aktif katılımlarına yardımcı olmada kullanılabilecek görsel araçlardan biri de kavram karikatürleridir. Bu çalışmada, öğretmen adaylarının kavram karikatürlerine ilişkin görüşlerinin belirlenmesi amaçlanmıştır. Çalışmaya, bir eğitim fakültesinde öğrenim gören fizik (20), kimya (10) ve biyoloji (21) programlarında öğrenim gören toplam 51 öğretmen adayı gönüllü olarak katılmıştır. Çalışmada, veri toplama aracı olarak sekiz açık uçlu sorudan oluşan bir anket kullanılmıştır. Araştırmadan elde edilen veriler, öğretmen adaylarının kavram karikatürleri ve kavram karikatürlerinin nasıl hazırlanacağı ile ilgili yeterli bilgiye sahip olmadığını göstermiştir. Öğretmen adaylarının kavram karikatürlerinin öğretim sürecinde kullanımı ve farklı fen konularında nasıl tasarlanacağı konusunda bilgilendirilmeleri önerilmektedir. Çünkü kavram karikatürleri mesleki yaşamlarında öğrenme ortamlarını zenginleştirebilmeleri açısından faydalı olacaktır.

Anahtar sözcükler: fen eğitimi, kavram karikatürü, öğretmen adayı

ABSTRACT: Learning tools that taking into consideration students' prior knowledge and making them active must be used in science education for more effective and permanent learning. The concept cartoons are one of visual tools that could be used to help students solve their problems in everyday life and actively participate in courses. In this study, it is to aim to determine prospective teachers' views on concept cartoons. For this aim, a total of 51 prospective teachers enrolled in physics (20), chemistry (10) and biology (21) teacher-training programs a faculty of education voluntarily participated in this study. In the present study, a questionnaire which consisted of eight open-ended questions was used as a data collection tool. The data obtained from this study showed that prospective teachers have not enough information about concept cartoons and how to prepare them. It was suggested that the prospective teachers should be informed of the usage of concept cartoons in the teaching process and how to design concept cartoons in different science subjects because the concept cartoons would be useful in terms of enriching the learning environment in their professional life.

Key words: science education, concept cartoon, prospective teacher

GİRİŞ

Öğrenme ve öğretmedeki bütünleştirici görüş, öğretmenlerden öğrencilerin var olan fikirlerini incelemelerini ve kavramsal karmaşa oluşturacak eğitimsel etkinlikler geliştirmelerini istemektedir (Posner, Strike, Hewson & Gertzog, 1982; Demircioğlu, Demircioğlu & Ayas, 2004). Bu etkinlikler aynı zamanda öğrencilerin öğrenme sürecine aktif olarak katılmalarını, bu süreçte yaparak-yaşayarak öğrenmelerini ve mevcut bilgileriyle yeni bilgilerini anlamlı olarak ilişkilendirmelerini sağlamalıdır. Söz konusu etkinliklerden biri de kavram karikatürleridir.

Kavram karikatürleri öğrencilerin hem günlük yaşama ilişkin problemleri çözmelerini hem de derse aktif katılımlarını sağlamak için kullanılabilecek görsel araçlardır (Balım, İnel & Evrekli, 2008). Bu araçlar, her bir karakterin günlük yaşamdaki bir olaya ilişkin farklı bakış açılarını savunduğu, ilgi çekici ve şaşırtıcı karikatür biçimindeki çizimlerdir (Keogh & Naylor, 1999; Martinez, 2004). Kavram karikatürleri, tartışmaya yol açmak (Long & Marson, 2003), öğrencilerin katılımını ve motivasyonunu artırmak, öğrenim ve öğretimi desteklemek (Keogh, Naylor, de Boo & Feasey, 1999; Uğurel & Morali, 2006), öğrencilerin günlük yaşamla fen arasında bağ kurmaları için bilimsel düşünceleri günlük yaşama uyarlamak (Keogh, Naylor & Wilson, 1998) amacıyla kullanılmaktadır.

Ayrıca kavram karikatürleri öğretmen ve öğrencileri meşgul ederek verimli öğretim ortamları oluşturmayı sağlayan ve kavramsal anlamayı geliştirmek için kullanılabilen bir araçtır (Akdeniz & Atasoy, 2006). Bu süreçte kavram karikatürleri, öğrencilerin fikirlerinin açığa çıkarılmasında (Stephenson & Warwick, 2002), kavramsal gelişimlerinin anlaşılmasında, öğrenmelerini sağlamada ve öğrencileri ilgili tutmada (Huang, Liu, Lin & Istanda, 2006) öğretmenlere yardımcı olmaktadır.

Peki, öğretmen adayları öğrenme ortamına katkı sağlamada bu denli etkili olan kavram karikatürleri ve onların nasıl tasarlanacağı konusunda yeterli bilgiye sahipler mi? Bir öğretmenin etkili bir öğretim gerçekleştirebilmesi için sadece konuyu iyi bilmesi yeterli olmaz. Aynı zamanda o konuyu nasıl öğretmesi gerektiğini de bilmelidir. Bunun için öğretmenin analogileri, resimleri, değişik ve hayatla irtibatlı örnekleri, açıklamaları, görsel unsurları kullanabilmesi, dersini daha anlaşılır hale getirmek için pratik formüller ve akılda kalıcı yöntemler üretebilmesi (Batur & Balcı, 2013) ve uygulayabilmesi son derece önemlidir. Öğretmen adaylarının kendi eğitimleriyle öğrencilerinin öğrenmelerine katkıda bulunacak, öğrenme ortamlarını zenginleştirmelerinde ve öğrencilerde var olan anlama güçlüklerini ortaya çıkarabilmelerinde yardımcı olacak eğlenceli ve öğretici araçlardan biri olan kavram karikatürleri hakkında yeterli kazanımlara sahip olmaları son derece önemlidir.

Bu bağlamda, bu çalışmanın amacı öğretmen adaylarının kavram karikatürlerine ilişkin görüşlerinin belirlenmesidir.

YÖNTEM

Bu araştırmada öğretmen adaylarının kavram karikatürlerine ilişkin görüşlerini belirleyebilmek için anket yöntemi kullanılmıştır. Anket yönteminin amacı, incelenen durumu etraflıca tanımlamak ve açıklamaktır (Çepni, 2009).

Örneklem

Çalışmanın örneklemini, eğitim fakültesi fizik (20), kimya (11) ve biyoloji (20) öğretmenliği programlarında öğrenim gören toplam 51 öğretmen adayından oluşmaktadır. Öğretmen adayları 5. sınıf öğrencileridir ve çalışmaya gönüllü olarak katılmışlardır.

Veri Toplama Aracı

Öğretmen adaylarının kavram karikatürlerine ilişkin görüşlerini belirlemek için 8 açık uçlu sorudan oluşan bir anket kullanılmıştır. Anket soruları İnel, Balım ve Evrekli (2009) tarafından yapılan çalışmadan yararlanılarak araştırmacılar tarafından farklı sorular da eklenerek yeniden düzenlenmiştir. Anketteki soruların geçerlik çalışması için, uzman görüşüne başvurulmuştur. Bunun yanında örneklem dışında 5 öğrenciye pilot uygulama yapılarak ankete son şekli verilmiştir.

Verilerin Analizi

Öğretmen adaylarının kavram karikatürüne ilişkin görüşlerinin belirlendiği 8 açık uçlu sorudan oluşan anket, betimsel olarak analiz edilmiştir. Ankette yer alan 6 sorudan elde edilen veriler temalar oluşturularak frekans dağılımları ve yüzde hesaplamaları şeklinde sunulmuştur. Yedinci sorudaki veriler, ortak öğrenci görüşleri derlenerek verilmiştir. Anketin son sorusu olan “ Herhangi bir konu ya da kavramla ilgili kavram karikatürü çizer misiniz?” sorusuna cevap olarak çizilen karikatürler üç farklı seviyede değerlendirilmiştir. Çizilen karikatürlerin dereceleri ve bu derecelere karşılık gelen açıklamalar Tablo 1’de verilmiştir.

Tablo1. Çizilen Karikatürlerin Dereceleri ve Bu Derecelere Karşılık Gelen Açıklamalar

Derece	Açıklama
1.	Bir kişinin baloncuk içerisinde görüşünü ifade etmesi
2.	İki kişinin olay hakkında konuşması, farklı görüşler ifade edilmemiş
3.	İki ya da daha fazla kişinin olay hakkında konuşması, farklı görüşlerin ifade edilmesi

BULGULAR

Bu bölümde araştırmacılar tarafından hazırlanan açık uçlu anket sorularına öğrencilerin verdikleri cevaplar ve bu cevaplara ilişkin frekans değerlerine yer verilmiştir. Öğrencilerin bir soruya verdikleri cevap içerisinde yer alan birden fazla görüş analize dâhil edilmiştir.

Tablo 2. “Kavram Karikatürü Denilince Aklınıza Ne Geliyor?” Açık Uçlu Sorusuna İlişkin Öğretmen Adaylarının Görüşleri ve Frekans Değerleri

Katılımcı ifadeleri	Fizik	Kimya	Biyoloji
Kavramların karikatüre aktarılması	5	3	5
Konuşma diyagramları	4	2	3
Çizgi resimler	4	3	3
Konuları görselleştiren materyaller	4	2	4
Mizahi şekiller	-	2	2
Kavram yanlışlarını giderici materyaller	2	2	4
Öğretici şekiller	-	-	2
Açıklayıcı diyagramlar	2	1	-

“Kavram karikatürü denilince aklınıza ne geliyor?” sorusuna öğretmen adaylarının birçoğu “kavramların karikatürize edilmesi, karikatüre aktarılması” şeklinde cevap vermiştir. Bunun yanında verilen diğer ifadelerin de benzer olduğu görülmüştür.

Tablo 3. “Daha Önce Kavram Karikatürleri İle Herhangi Bir Yerde Hiç Karşılaştınız mı?” Açık Uçlu Sorusuna İlişkin Katılımcıların Görüşleri ve Frekans Değerleri

İfadeler	Fizik	Kimya	Biyoloji
Ders kitaplarında	3	3	3
Lisans derslerinde	4	2	3
KPSS kitaplarında	5	4	6
Gazetelerde	2	2	1
Dergilerde(mizahi)	2	-	2
İlköğretim çalışma kitaplarında	5	4	6
Hiç karşılaşmadım	1	1	-

“Daha önce kavram karikatürleri ile herhangi bir yerde hiç karşılaştınız mı?” açık uçlu sorusuna ilişkin öğretmen adayları kavram karikatürleri ile daha çok ilköğretim çalışma kitapları ve KPSS test kitaplarında karşılaştıklarını belirtmişlerdir.

Tablo 4. “Kavram Karikatürleri Hangi Özelliklere Sahip Olmalıdır?” Sorusuna İlişkin Katılımcıların Görüşleri ve Frekans Değerleri

İfadeler	Fizik	Kimya	Biyoloji
Dikkat çekici	10	7	8
Açık ve anlaşılır	6	4	6
Gerçeğe uygun	5	-	-
Konuya uygun	6	3	5
Kavram yanlışlarını giderici	4	5	4
Öğrenci düzeyine uygun	-	4	-
Renkli, eğlenceli	3	5	3
Öğretici, bilgi verici	2	4	5
Güncel	3	-	-

“Kavram karikatürleri hangi özelliklere sahip olmalıdır?” sorusuna ilişkin öğretmen adaylarının büyük çoğunluğu “dikkat çekici ve anlaşılır” olmalıdır şeklinde görüş bildirmişlerdir. Diğer yanıtlar incelendiğinde katılımcıların benzer ifadeler kullandıkları görülmüştür.

Tablo 5. “Kavram Karikatürlerinin Avantajları ve Dezavantajları Nelerdir?” Sorusuna İlişkin Katılımcıların Görüşleri ve Frekans Değerleri

Avantajlar	Fizik	Kimya	Biyoloji
Dikkat çeker	8	6	7
Dersi ilgiyi artırır	-	3	6
Kalıcı öğrenme sağlar	9	6	7
Kavram yanlışlarını giderir	3	-	5
Dersi eğlenceli hale getirir	4	3	4
Derse katılımı artırır	5	2	3
Yaratıcı düşünmeyi geliştirir	-	2	3
Dezavantajlar			
Kavram yanlışını oluşturur	5	3	4
Her konuya uygulanmaz	6	5	5

Hazırlanması zor ve zaman alıcı	4	-	3
Konuları yüzeysel anlatır	5	4	4
Dikkat dağıtabilir	4	3	4

“Kavram karikatürlerinin avantajları ve dezavantajları nelerdir?” sorusuna yönelik cevaplarda öğretmen adayları; kavram karikatürlerinin “dikkat çekici ve kalıcı öğrenmeyi sağlayıcı” özelliklerinin en önemli avantaj olduğunu belirtmişlerdir. Bunun yanında “her konuya uygulanmaz ve kavram yanılgısı oluşturabilir” ifadeleri ile de dezavantajlarına değinmişlerdir.

Tablo 6. “Kavram Karikatürlerini Derslerinizde Hangi Amaçla Kullanırsınız?” Sorusuna İlişkin Katılımcıların Görüşleri ve Frekans Değerleri

İfadeler	Fizik	Kimya	Biyoloji
Dikkat çekmek	5	4	5
Öğrencileri motive etmek	4	3	3
Dersi eğlenceli hale getirmek	3	4	5
Kalıcı öğrenme sağlamak	4	3	3
Kavram yanılgılarını tespit etmek	-	2	2

“Kavram karikatürlerini derslerinizde hangi amaçla kullanırsınız?” sorusuna ilişkin cevaplarda öğretmen adayları; dersin başında “dikkat çekmek, öğrencilerde merak uyandırmak ve motivasyonlarını arttırmak” amacıyla kullanacaklarını belirtmişlerdir. Ayrıca kavram karikatürleri ile dersleri daha eğlenceli hale getireceklerini ve kalıcı öğrenme sağlayacaklarını ifade etmişlerdir.

Tablo 7. “Kavram Karikatürleri Bütün Derslerde Kullanılır mı?, Sizce Hangi Derslerde Kullanılmalıdır?” Sorusuna İlişkin Katılımcıların Görüşleri ve Frekansları

İfadeler	Fizik	Kimya	Biyoloji
Tüm derslerde	5	4	5
Fen derslerinde	8	5	7
Soyut kavramlar içeren derslerde	-	3	2
Günlük hayatla ilişkili derslerde	3	3	2
Özellikle ilköğretim derslerinde	4	-	4

“Kavram karikatürleri bütün derslerde kullanılır mı?, Sizce hangi derslerde kullanılmalıdır?” sorusuna öğretmen adayları, kavram karikatürlerinin tüm derslerde kullanılabilir olduğunu özellikle de fen bilimleri gibi soyut dersler için daha uygun olduğunu belirtmişlerdir.

Öğretmen adaylarına 7. soruda “Kavram karikatürleri konusunda yeterli bilgi ve donanımına sahip olduğunuzu düşünüyor musunuz?” sorusu sorulmuştur. Elde edilen verilere göre; öğretmen adaylarının birçoğu bu konuda yeterli olmadıklarını, kavram karikatürünü sadece teorik olarak işlediklerini, uygulamaya yönelik bir çalışma yapmadıklarını belirtmişlerdir. Bazı öğretmen adayları “kavram karikatürü” kavramı ile ilk kez karşılaştığını, karikatürü sadece gazete ve dergilerdeki mizahi şekiller olarak düşündüklerini ifade etmişlerdir.

Tablo 8. “Herhangi Bir Konuda Kavram Karikatürü Çizer misiniz?” Sorusuna İlişkin Öğretmen Adaylarının Puanlarına Göre Dereceleri

Derece	Fizik	Kimya	Biyoloji
1.	7	4	8
2.	10	4	10
3.	3	2	3

Tablo 8’de görüldüğü gibi 51 öğretmen adayından sadece 8 tanesi kavram karikatürü formatında doğru çizimler yapmışlardır. Öğretmen adaylarının yaptığı çizimlerden her dereceye ait bir örnek çizimler Şekil 1’de verilmiştir.

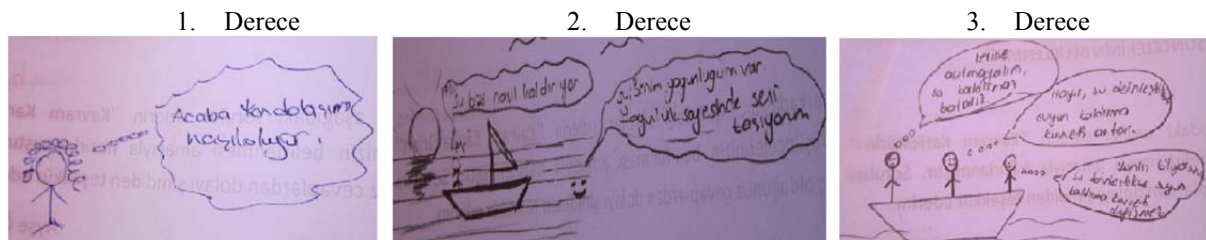

Şekil 1. Öğretmen Adaylarının Kavram Karikatürü Çizimleri SONUÇLAR VE ÖNERİLER

Araştırmadan elde edilen sonuçlar, öğretmen adaylarının kavram karikatürleri ve kavram karikatürlerinin nasıl hazırlanacağı ile ilgili yeterli bilgiye sahip olmadığını göstermiştir. Öğretmen adayları kavram karikatürlerinin “dikkat çekici, eğlenceli, yaratıcı düşünmeyi geliştiren, kalıcı öğrenmeyi sağlayan ve kavram yanlışlarını gideren” görsel araçlar olduğunu ifade etmişlerdir. Bunun yanı sıra, doğru bir şekilde kullanılmadıklarında dikkati dağıtabileceklerini, farklı kavram yanlışlarını oluşturabileceklerini dile getirmişlerdir. Farklı kaynaklarda kavram karikatürlerine rastladıklarını ve özellikle fen bilimleri gibi soyut kavramlar içeren derslerde kullanımlarının daha uygun olduğunu söylemişlerdir. Ancak herhangi bir konu ya da kavramla ilgili bir kavram karikatürü çizmeleri istendiğinde yeterli içeriğe sahip çok fazla kavram karikatürü çizimiyle karşı karşıya kalınmamıştır. Elde edilen sayı beklenen oldukça altında olmuştur. Bu durumun eğitimle ilgili derslerin daha ziyade teorik olarak işlenmesinden ve öğretmen adaylarının yeterince uygulamalar yapmamasından kaynaklandığı düşünülmektedir. Son sınıf öğrencileri oldukları için girecekleri KPSS sınavına fazlaca odaklanmış olmaları ve derslerde yalnızca geçmek için çaba sarf etmeleri de nedenlerden biri olabilir.

Bu sonuçlar doğrultusunda, öğretmen adaylarının kavram karikatürlerinin öğretim sürecinde kullanımı ve farklı fen konularında nasıl tasarlanacağı konusunda bilgilendirilmeleri önerilmektedir. Çünkü kavram karikatürleri mesleki yaşamlarında öğrenme ortamlarını zenginleştirebilmeleri açısından faydalı olacaktır. Eğitim derslerinde, özellikle materyal geliştirme, örnek etkinliklere yer verilmeli ve öğretmen adaylarından kendi kavram karikatürlerini hazırlamaları istenmelidir. Ayrıca öğretmen adaylarının birebir kavram karikatürlerinin etkililiğini belirlemek amacıyla çeşitli araştırmalar gerçekleştirmesi sağlanmalı ve elde ettikleri sonuçları arkadaşlarıyla paylaşarak farklı durumları incelemelerine fırsat verilmelidir.

KAYNAKLAR

- Akdeniz, A.R. & Atasoy, Ş.(2006). Kavram karikatürlerinin havaya fırlatılan topa etkileyen kuvvet konusundaki kavram yanlışlarını gidermeye etkisi. *VII. Ulusal Fen Bilimleri ve Matematik Eğitimi Kongresi*. Ankara.
- Balım, A., İnel, D. & Evrekli, E. (2008). The effects of using concept cartoons in science education on students' academic achievements and enquiry learning skill perceptions. *Elementary Education Online*, 7(1), 188-202.
- Batur, Z. & Balcı, S. (2013). Türkçe öğretmen adaylarının pedagojik alan bilgilerinin incelenmesi. *Adıyaman Üniversitesi Sosyal Bilimler Enstitüsü Dergisi Türkçenin Eğitimi Öğretimi Özel Sayısı*, 6(11), 21-43.
- Çepni, S. (2009). *Araştırma ve proje çalışmalarına giriş*. Geliştirilmiş 4. Baskı, Pegem Akademi, Trabzon.
- Demircioğlu, H., Demircioğlu, G. ve Ayas, A. (2004). Sınıf öğretmeni adaylarının bazı temel kimya kavramlarını anlama düzeyleri ve karşılaşılan yanlışlar. *Hasan Ali Yücel Eğitim Fakültesi Dergisi*, 1, 29-50.
- Huang, T. H., Liu, Y. C., Lin, T. Y. & Istanda, V. (2006). Construction of integrating of concept cartoons into two tier on-line testing system. *IADIS International Conference*, 34-38.
- İnel, D., Balım, A. & Evrekli, E. (2009). Fen öğretiminde kavram karikatürü kullanımına ilişkin öğrenci görüşleri. *Necatibey Eğitim Fakültesi Elektronik Fen ve Matematik Eğitimi Dergisi*, 3(1), 1-16.
- Keogh, B., Naylor, S., de Boo, M. & Feasey, R. (1999). The use of concept cartoons as an auditing tool in initial teacher training Research in Science Education. *2nd International Conference of the European Science Education Research Association*, Kiel, Germany.
- Keogh, B. & Naylor, S. (1999). Science Goes Underground. *Adults Learning*, 10(5), 6-8.
- Keogh, B., Naylor, S. & Wilson, C. (1998). Concept cartoons: A new perspective on physics education. *Physics Education*, 33(4), 219-224.
- Long, S. & Marson, K. (2003). Concept cartoons. *Hands on Science*. 19(3).
- Martinez, Y. M. (2004). *Does the K-W-L reading strategy enhance student understanding in honors high school science classroom?* Unpublished masters thesis, California State University, Fullerton.
- Posner, G. J., Strike, K. A., Hewson, P. W. & Gertzog, W. A. (1982). Accomodation of a scientific conception: Toward a theory of conceptual change. *Science Education*, 66, 211-227.
- Stephenson, P. & Warwick, P. (2002) Using concept cartoons to support progression in students' understanding of light. *Physics Education*, 37(2), 135-141.
- Uğurel, I. & Moralı, S. (2006). Karikatürler ve matematik öğretiminde kullanımı. *Milli Eğitim Dergisi*, 35(170), 47-66.

İLKÖĞRETİM MATEMATİK ÖĞRETMENLİĞİ ÖĞRENCİLERİNİN SİLİNDİR KAVRAMINA DAİR KAVRAM İMAJLARININ İNCELENMESİ

Mehmet GÜZEL
Gaziantep Üniversitesi
mmtgz11@gmail.com

Ali BOZKURT
Gaziantep Üniversitesi
alibozkurt@gantep.edu.tr

Yusuf KOÇ
Gaziantep Üniversitesi
ykoc@gantep.edu.tr

ÖZET: Bu çalışmada ilköğretim matematik öğretmenliği öğrencilerinin silindir kavramına dair kavram imajları incelenmiştir. Araştırmanın örneklemini Türkiye'nin güneyindeki bir devlet üniversitesinde 2011-2012 öğretim yılı ilköğretim matematik öğretmenliği öğrencilerinden geometri dersini alan toplam 111 öğrenci oluşturmaktadır. Veri toplama aracı olarak üç boyutlu geometrik kavramlara dair açık uçlu soruların bulunduğu bir form uygulanmıştır. Katılımcılardan, bu formda verilen kavramlarla ilgili çağrışımları yazmaları ve uygun olanların şekillerini çizmeleri istenmiştir. Bu çalışma kapsamında bu formda yer alan silindir kavramıyla ilgili veriler nitel olarak analiz edilmiştir. Analizlerden elde edilen bulgulardan katılımcıların genel olarak çağrışımdan ziyade tanım yapma eğiliminde oldukları ve şekilleri betimlemeye çalıştıkları görülmüştür. Ayrıca şekillerin yanal yüzeylerine ve tabanlarına aşırı bir vurgu göze çarpmaktadır. Öte yandan katılımcıların büyük bir çoğunluğunun silindir kavramını, dik dairesel silindir özelinde ele aldıkları görülmüştür. Bu verilere dayanarak katılımcıların büyük çoğunluğunun silindir kavramıyla ilgili kavram imajlarının zengin olmadığı veya yanlış kavram imajlarına sahip oldukları söylenebilir.

Anahtar sözcükler: Geometri öğretimi, kavram imajı, silindir

ABSTRACT: In this study, elementary mathematics education student's concept image about the concepts of cylinder was investigated. During this research we worked with 111 participants who are students at a state university which is located in the southern region of Turkey in the academic year 2011-2012. In order to collect data, a form including three dimensional geometrical concepts was utilized. The participants were asked to write the connotations about given concepts and draw the shapes of the appropriate ones. Within this study, the data about cylinder was analyzed qualitatively. It seems that the participants are generally inclinable to define and portrayal the shapes instead of trying to connotative them. Also there is a conspicuity that, there were an over-emphasize on the planar geometrical shapes which appears on the face of the certain concepts. On the other hand, most of the participants have a sense of the right circular cylinder as cylinder. As the result of collected data, we can say that participants' concept image about cylinder could not be enriched. In addition, they have some incorrect concept images.

Key words: Teaching geometry, concept image, cylinder

GİRİŞ

Kavramsal öğrenme matematikte ve özellikle de geometride önemli bir yer teşkil etmektedir (Altun, 2002). Kavramsal öğrenmenin gerçekleşmesi için kavramların biliniyor olması bir zorunluluktur. Ancak matematiksel kavramlara ait tanımların öğrencilerde kalıcı olup olmadığı konusu gündeme gelmektedir. Vinner (1991)'e göre tanımlar uzun vadede unutulmaktadır. Ayrıca öğrencilerin matematiksel kavramların tanımları konusunda zorluklar yaşadığına dair çalışmalara rastlamak ta mümkündür (Matos, 1994; Ubuz, 1999). Şu halde kavramların doğru anlaşılması için öğrencilerin kavramlarla ilgili doğru kavram imajları oluşturmaları bir gerekliliktir. Kavramların doğru anlaşılması matematiği anlamakta önemli olduğu kadar matematiksel konularda iletişim için de önemlidir. İletişim sırasında ilk akla gelen bilgiler ise verilen kavramla ilgili kavram imajlarıdır.

Buradan hareketle verilen kavramlara dair kavram imajları ve bu kavram imajlarının ne kadar zengin olduğunu ortaya koymak önemlidir.

Kavram İmajı

Öğrencilerin bir kavramla ilgili kendilerince oluşturulan fikirler kavram imajı olarak ifade edilmektedir (Tall ve Vinner, 1983). Başka bir ifadeyle; bir öğrencinin bir kavramla ilgili bütün zihinsel görüntüleri o öğrencinin verilen kavramla ilgili kavram imajı olarak tanımlanmıştır. Öyle ki bu zihinsel görüntüler bazen öğrencilerin o kavram söylendiğinde zihninde canlandırdığı diğer kavramlarla da ifade edilebilir. Vinner (1983) öğrencilerin bir kavramı öğrendikten uzun bir süre sonra kendisine kavram ile ilgili verilen görevlerde tanımlı kullanabileceği gibi kavram imajını da kullanabileceğini belirtmiştir. Hatta öğrenmeler informal ortamlarda gerçekleşmişse, kavram tanımının hiç kullanılmayacağı kavram imajının kullanılacağı belirtilmektedir. Kavram imajları ise her zaman bilimsel görüşlerle uygun düşmeyebilir (Gutierrez ve Jaime 1999).

Araştırmada katılımcıların silindir kavramına dair kavram imajları incelenmiştir. Bu bağlamda silindir kavramının formal tanımını ele almak gerekir. Çünkü formal ortamlarda kavramların öğrenilmesinde tanımlar önemli bir rol oynamaktadırlar, bir kavrama ait tanımın açık, anlaşılır ve ekonomik olması önemlidir (Çakıroğlu, 2013).

Silindir

Literatürde silindirin farklı tanımlarına rastlamak mümkündür örneğin bir kaynakta: Silindir, prizmanın tabanının kenar uzunluklarının kısalması ve kenar sayısının sonsuza gitmiş halidir (Altun, 2002). Denilmektedir bu tanımlama silindiri özel bir prizma olarak kabul etmektedir. Ayrıca aynı kaynakta, silindir dendiğinde “dik dairesel silindir” kavramının kastedildiğini, diğer silindir türlerinin özellikle belirtilmesi gerektiğinden bahsedilmektedir. Nitekim Dönmez (2002)’ de silindir kavramı tanımı verilirken sadece dairesel silindiri kapsayan bir tanım verilmiştir. Tanım ifadesinde silindirin tabanlarının aynı yarıçaplı daireler olduğu söylenmiştir. Bu tanımlarda tabanların paralelliklerinden, silindirin içinin dolu veya boş olacağından veya herhangi başka bir özellikten bahsedilmeden sadece tabanları aynı yarıçaplı dairelerden oluşan şekil silindir olarak kabul edilmiştir. Diğer taraftan Kruglak ve Moore (1963 ss:158,160);

MN düzlemde bir eğri ve QR bu düzlemde olmayan bir doğrultman doğru olmak üzere (resim 1) bir ST doğrusu eğri boyunca QR doğrusuna paralel olacak şekilde hareket ettirilirse silindirik yüzey elde edilmiş olur. ST doğrusunun her konumuna ise “doğrultman” denir. Eğer MN eğrisi kapalı bir eğriyse elde edilen yüze kapalı silindirik yüzey olarak adlandırılır. Kapalı bir silindirik yüzeyin iki paralel düzlemlerle kesilmesi sonucu oluşan şekle ise silindir denir.

Biçiminde tanımlamaktadır. Benzer tanım farklı kaynaklarda da yer almaktadır (Demirtaş, 1986; ...). Yapılan tanımlara bakıldığında silindirin bir düzlemde bulunan bir eğri üzerinde belli bir açıyla hareket ettirilen bir doğrunun ilk düzleme paralel bir düzlemlerle kesilmesi sonucu oluşan üç boyutlu geometrik şekil, olduğunu söylemek mümkündür. Bu tanımlama biçimi silindiri, silindirik yüzey kavramı ile ilişkilendirerek tanımlamaktadır.

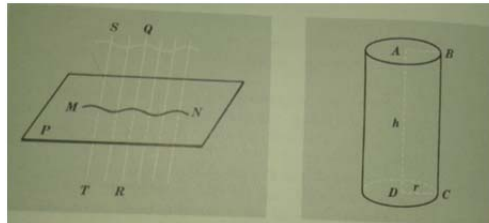

Resim 1: Kruglak Ve Moore'de Verilen Silindir Resmi

Ayrıca Van De Walle (2004)’ a göre silindir genel anlamda sınırsız açık bir yüzey özel anlamda ise tabanları olan ve bir yüzeyle sınırlı kapalı, içi boş cisimdir(s.423). Silindir için söz konusu kaynakta verilen görsel ise resim 1’de verilmiştir.



resim 2. Silindirler Ve Silindir Olmayan Şekiller

Söz konusu kaynakta silindir tanımı ise hiyerarşik olarak prizmaya dayandırılarak da yapılmıştır. Tanımda tabanları çokgen olan silindirler prizma olarak adlandırılır. Şeklinde bir ifadeye yer verilmiştir. (Van de Walle, Karp ve bay-Williams, 2013).

Araştırma konusu olan silindir kavramı gündelik hayatta başka alanlarda kullanılan kavramlardır ve bu kavramın informal ortamlarda öğrenilmesi beklenen bir durumdur. İnfomal ortamlarda veya günlük hayatta silindir olarak adlandırılan cisimler ise matematiksel olarak bu kavramı karşılamayabilirler. Şu halde öğrencilerin bu kavramla ilgili formal ortamlarda da belli bir birikim kazandıktan sonra ve söz konusu öğrenmelerin üzerinden belli bir zaman geçtikten sonra kavram imajlarının nasıl şekilleneceği sorusu gündeme gelmektedir. Bu bağlamda bu çalışmada geometrik kavramlardan silindire dair katılımcıların kavram imajları incelenmiştir.

YÖNTEM

Bu çalışma nitel bir yöntem kullanılmıştır. Nitel araştırmalar kişi davranışlarının nedenlerini anlamaya dönük çalışmalardır. (Arlı ve Nazik, 2001:14).

Örneklem

Bu araştırmanın örneklemini 2011-2012 öğretim yılı, bahar döneminde Türkiye'nin güneyindeki bir devlet üniversitesinde Eğitim Fakültesi İlköğretim Matematik Öğretmenliği programı kapsamında GEİM 106 GEOMETRİ dersi alan, 86 bayan ve 25 erkek toplam 111 ilköğretim matematik öğretmenliği öğrencisi oluşturmaktadır.

Veri Toplama Aracı

Bu veri toplama aracı bir araştırma projesi bağlamında hazırlanmıştır. Veri toplama aracında katılımcıların üç boyutlu şekillere dair kavram imajlarının belirlenmesi planlanmıştır. Bu amaçla proje yürütücüleri tarafından bir ölçek üzerinde çalışılmış anlaşılmayan sorular düzenlenmiş ve ölçeğe son hali verilerek veri toplama aracı olarak kullanılmıştır. Bununla beraber aracın kullanılabilirliği için alanda uzman iki akademisyenin görüşlerine başvurulmuştur. Veri toplama aracında prizma, silindir, piramit, koni ve küre kavramlarının katılımcılara ne çağrıştırdığı sorulmuş ve çizimlerini yapmaları istenmiştir. Ancak araştırma kapsamında silindir kavramları ile ilgili katılımcı cevapları analiz edilmiştir.

Veri Analiz Süreci

Verilerin sayısallaştırılması işlenmesi ve karşılaştırmalı değerlendirmenin yapılabilmesi kodlama işlemidir (Bal, 2001:160). Verilerin kodlanmasında Pilkington (2001)'de verilen içerik analizi metodu kullanılmıştır. Bu doğrultuda katılımcıların verdiği cevaplar incelenerek tekrar eden cevaplar kodlanmıştır (akt: Bozkurt 2012). Ayrıca katılımcıların cevaplarında göze çarpan bazı noktalar "genel gözlemler" başlığı altında verilecektir. Araştırmaya katılan katılımcıların verdiği cevaplardan oluşturulan kategoriler Tablo 1'de gösterilmiştir.

Tablo 1: Silindir kavramı için oluşturulan kategoriler

Simge	Kategori	Örnek
S	Dik dairesel silindir çizimi yapanlar	 (#11)
AS	Silindiri, bir dikdörtgen ve iki dairenin birleşimi olarak ifade edenler	-İki daire ve bir dikdörtgenin birleşiminden oluşan geometrik şekildir.

BS	Silindiri, bir dikdörtgen ve iki çemberin birleşimi olarak ifade edenler	- İki eş çember ve eni h boyu çemberin çapının iki katı olan dikdörtgenden oluşmuş şekil.
CS	Silindiri, tabanı daire olan bir prizma şeklinde ifade edenler	-Tabanı daire olan prizmadır.
DS	Silindiri, tabanı çember olan prizma şeklinde ifade edenler	-Alt ve üst tabanı birbirine eş iki çemberden oluşan prizmadır.
ES	Silindiri, “bir dikdörtgenin herhangi bir kenarı etrafında döndürülmesiyle oluşan şekil” olarak ifade edenler	-Bir dikdörtgenin bir kenarı etrafında 360° döndürülmesi ile oluşan şekildir.
FS	Silindiri, “dikdörtgenin bükülmesi veya yuvarlanmasıyla oluşan şekil” olarak ifade edenler.	-Bir dikdörtgenin yuvarlanıp boş kalan kısımların eşit daireler yerleştirilmesi sonucu oluşan şekil.
GS	Silindirin üç boyutlu bir cisim olduğundan bahsedener	-Silindir üç boyutlu bir cisimdir, kalemin alt tarafı gibi.
HS	Betimleme yapanlar	-Aralarında mesafe bulunan 2 dairenin birçok çizgi ile birleştirilmesi sonucu oluşan üç boyutlu şekil.
IS	Silindir için günlük hayattan örnek verenler	-İki daireden ve bir dikdörtgenden oluşur günlük hayattan örnek vermek gerekirse borular olabilir.

Katılımcı cevaplarının çoğu birden fazla kategoride değerlendirilebilecek cevaplardır. Bu nedenle kategorilerde elde edilen cevap sayısı katılımcı sayısından fazla olmuştur. Ayrıca sayısal olarak analiz edilen bu bulguların dışında katılımcıların cevaplarında dikkat çeken bazı hususlar genel gözlemler başlığı altında verilmiştir.

BULGULAR

Katılımcıların verdiği cevaplardan oluşturulan kategoriler

Çalışmanın bu bölümünde veri toplama aracında yer alan silindir kavramlarının katılımcılardaki kavram imajlarına dair elde edilen veriler analiz edilmiştir. Tablo 2’de silindir ile ilgili bulguların frekansları gösterilmektedir.

Tablo 2: Silindir İle İlgili Katılımcıların Kavram İmajlarına Dair Bulgular

Kategori	Frekans
Dik dairesel silindir çizimi yapanlar	109
Silindiri, bir dikdörtgen ve iki dairenin birleşimi olarak ifade edenler	34
Betimleme yapanlar	32
Silindirin üç boyutlu bir cisim olduğundan bahsedener	26
Silindir için günlük hayattan örnek verenler	20
Silindiri, “dikdörtgenin bükülmesi veya yuvarlanmasıyla oluşan şekil” olarak ifade edenler.	11
Silindiri, bir dikdörtgen ve iki çemberin birleşimi olarak ifade edenler	10
Silindiri, “bir dikdörtgenin herhangi bir kenarı etrafında döndürülmesiyle oluşan şekil” olarak ifade edenler	7
Silindiri, tabanı daire olan bir prizma şeklinde ifade edenler	4
Silindiri, tabanı çember olan prizma şeklinde ifade edenler	2

Tablo 2 incelendiğinde silindiri çizmeleri istenen katılımcılardan 109’u dik dairesel silindir çizimi yaptığı görülmektedir. Yine Tablo 2’den silindir kavramına dair çağrışım cevapları incelendiğinde ise 34 katılımcının bir dikdörtgen ve iki dairenin birleşimi olarak ifade ettiği, 32 katılımcının betimleme yaptığı, 26 katılımcının silindirden üç boyutlu bir cisim olarak bahsettiği, 20 katılımcının ise silindirin üç boyutlu bir cisim olduğundan bahsettiği görülmektedir. Ayrıca bazı katılımcılarda silindiri, dikdörtgenin bükülmesi veya yuvarlanmasıyla oluşan şekil (11), bir dikdörtgen ve iki çemberin birleşimi (10), bir dikdörtgenin herhangi bir kenarı etrafında döndürülmesiyle oluşan şekil (7), tabanı daire olan bir prizma (4) ve tabanı çember olan prizma (2) şeklinde ifade etmişlerdir.

Silindir kavramının katılımcılarda yaptığı çağrışımlara dair genel gözlemler

Katılımcılara silindir kavramının ne çağrıştırdığı sorulmasına rağmen çoğunlukla silindirin matematiksel özelliklerini yazmaya çalıştıkları gözlenmektedir (62 katılımcı). Ayrıca katılımcıların büyük bir çoğunluğu silindir çiziminde dik dairesel silindir çizmiş (109 katılımcı) ve kategorilerde de görüldüğü üzere kavram imajlarını da bu şekilde oluşturmuşlardır.

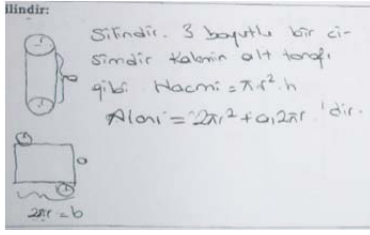

resim 3: #9 numaralı katılımcı silindir çizimi



resim 4: #11 numaralı katılımcının

TARTIŞMA

Katılımcıların hemen hemen hepsinin silindiri, dik dairesel silindir olarak algılamaları ve çizimleri buna göre yapmaları silindir kavramını dik dairesel silindire indirgediklerini düşündürmektedir. Bu durum literatürde verilen tanımlarla örtüşmektedir. (Altun, 2002, Dönmez, 2002). Ayrıca katılımcıların önemli bir çoğunluğu (107 tanesi) silindiri tarif ederken silindirin açık halinde oluşacak şekillerden bahsetmiştir. Bu durum, katılımcıların öğretim süreçlerinde geometrik cisimlerin açık halinin fazlaca vurgulanmasının bir sonucu olarak yorumlanabilir. Nitekim ilkököl 3. sınıf matematik ders kitabında silindir kavramı “geometrik cisimlerin yüzleri ve yüzeyleri” başlığı altında verilmiştir ve silindir için ilk görsel resim 5’deki gibidir (Coşkuntürk vd., 2012). Ayrıca 6. Sınıfta Dik dairesel silindirin temel elemanlarını belirlemeye dair, 7. Sınıfta ise dik dairesel silindirin yüzey alanı ve hacmi hesaplamaları yaptırılmasının istendiği görülmektedir. Görüldüğü gibi Silindir kavramı öğrencilere ilkököl, ortaokul, lise ve lisans öğrenimi esnasında ayrı ayrı işlenmektedir. Bu aşamaların her birinde silindir kavramı için yapılan tanımlar ve verilen örnekler birbirlerinden farklıdır. (MEB, 2005) bu farklılık genellikle daha alt seviyelerde daha basit ve anlaşılır ifadeler kullanılarak tanım yapma isteğinden kaynaklanmaktadır. Ancak öğrenciler silindir başlığı altında sürekli dairesel silindir örnekleri görüp bunlarla bir kavram imajı oluşturursa bu kavram imajının dairesel silindir dışındaki silindirleri kapsamayacağı iddia edilebilir. MEB programında bu durum açıkça göze çarpmaktadır.

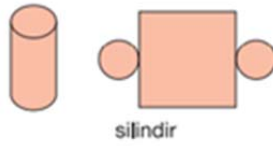

Resim 3. İlköğretim 3. sınıf ders kitabında silindir için verilen görsel (MEB, 2005)

Resim 2’de görüldüğü gibi silindir ve silindir yüzeyinin açık hali beraber verilmiştir. Vinner (1983)’te değinildiği gibi bir ders kitabında ikizkenar üçgenler için verilen bütün örneklerde taban yatay çizilmişse öğrencilerin sadece tabanı yatay olan ikizkenar üçgenleri ikizkenar kabul etmesi sürpriz olmayacaktır. Aynı şekilde ders kitaplarında silindirler bir dikdörtgen ve iki daire ile beraber verildiğinde öğrencilerin silindir ile ilgili kavram imajlarının bu şekilde oluşması da sürpriz değildir. Bu ve benzer şekil ve temsillerin silindir ile ilgili kavram imajlarını sınırlandıracağı düşünülebilir. Nitekim Vinner (1983) öğrencilere verilen spesifik örneklerin kavram imajlarını sınırlandırabileceği, hatta hatalara sebep olabileceğini belirtmiştir.

Katılımcılardan bazıları silindirin tabanını çember olarak ifade etmişlerdir. Ayrıca verilen örneklerde silindirin tabanının çember mi yoksa daire mi olacağı veya herhangi bir kapalı eğri mi olacağı konusunda katılımcıların net cevaplar vermediği görülmüştür. Bu durumda ders kitaplarında silindir için verilen tanımlarda silindirin içinin dolu olup olmayacağı veya tabanının hangi geometrik şekil olacağına net olarak vurgulanmadığını veya öğretmenlerin bu noktaya vurgu yapmadığını düşündürmektedir.

Silindir ile ilgili günlük hayattan örnek vererek açıklayan katılımcıların çoğu (20 kişiden 17’si) benzer örnekler vermiştir. (bardak, soba borusu vb.) Çevremizdeki nesnelere verilen örneklerin her zaman silindir olmayacağı unutulmamalıdır. Örneğin günlük hayatta kullanılan her bardağın görüntüsü silindir olarak ifade edilemez.

KAYNAKLAR

- Altun, M. (2002). *İlköğretim ikinci kademedeki (6, 7 ve 8. sınıflarda) matematik öğretimi. Alfa Basım Yayın Dağıtım, İstanbul.*
- Arlı, M. ve Nazik, H. (2001) *Bilimsel Araştırmaya Giriş*, Gazi Kitabevi, Ankara s.14.
- Bingolbalı, E. ve Monaghan, J. (2008). Concept image revisited. *Educational Studies in Mathematics*, 68(1), 19-35.

- Bingölbali, E. ve Özmantar, M. F. (2009). *Matematiksel Kavram Yanılgıları Sebepleri ve Çözüm Arayışları*, Matematiksel zorluklar ve çözüm önerileri. PegemA Akademi: Ankara.ss.1-30.
- Bozkurt, A., ve Koç, Y. (2012). İlköğretim Matematik Öğretmenliği Birinci Sınıf Öğrencilerinin Prizma Kavramına Dair Bilgilerinin İncelenmesi. *Kuram ve Uygulamada Eğitim Bilimleri*.
- Cilavdaroğlu, A.K. (2012) *İlköğretim Matematik Öğretmenliği Birinci Sınıf Öğrencilerinin bazı İki Boyutlu geometrik Kavramların Tanımları Ve Şekillerine Dair Bilgilerinin İncelenmesi*, Yüksek Lisans Tezi. Gaziantep Üniversitesi Sosyal Bilimler Enstitüsü, Gaziantep.
- Demirtaş, A. (1986). *Ansiklopedik matematik sözlüğü*. Bilim Teknik Kültür Yayınları.
- Dönmez, A. (2002). *Matematik Terimleri ve Formülleri*. Seçkin Yayıncılık. Ankara
- Gutiérrez, A., ve Jaime, A. (1999). Preservice Primary Teachers' Understanding of the Concept of Altitude of a Triangle. *Journal of Mathematics Teacher Education*, 2(3), 253-275.
- Kruglak, H., ve Moore, J. T. (1973). *Theory and Problems of Basic Mathematics: With Applications to Science and Technology*. McGraw-Hill.
- M.E.B., Talim ve T. K. Başkanlığı, (2005). *İlköğretim Matematik Dersi Öğretim Programı ve Klavuzu*. Devlet Kitapları Müdürlüğü, Ankara.
- Rösken, B. ve Rolka, K. (2007). Integrating intuition: the role of concept image and concept definition for students' learning of integral calculus. Montana Council of Teachers of Maths. *Montana Maths. Enthusiast, Monograph*, 3, 181-204.
- Soylu, Y. ve Aydın, S. (2006). Matematik derslerinde kavramsal ve işlemsel öğrenmenin dengelenmesinin önemi üzerine bir çalışma. *Erzincan Üniversitesi Eğitim Fakültesi Dergisi*, 8(2).
- Wilhelmi, M. R., Godino, J. D., ve Lacasta, E. (2007). Configuraciones epistémicas asociadas a la noción de igualdad de números reales. *Recherches en Didactique des Mathématiques*, 27(79), 77.
- Zembat, İ. Ö. (2013). Kavram yanılgısı nedir. Ed. MF Özmantar, E. Bingölbali ve H. Akkoç, *Matematiksel kavram yanılgıları ve çözüm önerileri*, 1-8.
- Tall, D. ve Vinner, S. (1981). Concept image and concept definition in mathematics with particular reference to limits and continuity. *Educational studies in mathematics*, 12(2), 151-169.
- Vinner, S. (1983). Concept Definition Concept Image and the Notion of Function, *International Journal for Mathematics Education in Science and Technology*, 14 (3), 293-305.

BİR KAMPÜS AĞINDA EN KISA UZUNLUKLU HAMILTON ÇEVRELERİN BULUNMASI

FINDING MINIMUM LENGTH HAMILTON CYCLES IN A CAMPUS NETWORK

Canan ÇİFTÇİ
Ege Üniversitesi
canan.ciftci@ege.edu.tr

Pınar DÜNDAR
Ege Üniversitesi
pinar.dundar@ege.edu.tr

ÖZET: Bir öğrenci bir duraktan başlayarak tüm duraklara tam bir kez uğrayıp başladığı durağa dönecek şekilde minimum ağırlıklı bir tur yapmak istemektedir. Burada i durağı ile j durağı arasındaki ağırlık bu iki durak arasındaki uzaklığı gösteren w_{ij} pozitif tamsayıdır. Bir G grafının tüm tepelerinden geçen bir çevrenin olup olmadığını bulma problemi Hamilton çevre problemi olarak, minimum ağırlıklı Hamilton çevrenin bulunması ise gezgin satıcı problemi olarak bilinmektedir. Bu çalışmada, ayrıt ağırlıklandırılmış bir grafın minimum uzunluklu Hamilton çevresini bulan bir algoritma tasarlanmış ve bu algoritma kullanılarak Ege Üniversitesi kampüsünde minimum ağırlıklı Hamilton çevrelerin varlığı araştırılmıştır.

Anahtar sözcükler: Hamilton çevre, gezgin satıcı problemi, ayrıt ağırlıklandırılmış graf, ağ.

ABSTRACT: Starting from a vertex, a student is willing to visit each city once and only once and then return to the starting city with minimal weight. Let w_{ij} be the distance between the cities i and j . The problem of determining whether there exists a cycle passing through all the vertices of a graph G or not, is known as Hamilton Cycle Problem. The problem of finding the Hamilton cycle with minimum weight, is also known as Travelling Salesman Problem. In this study, an algorithm is designed for finding Hamilton cycle with minimum length of an edge-weighted graph and with this algorithm, Hamilton cycles with minimum length are examined of Ege University Campus.

Key words: Hamilton cycle, travelling salesman problem, edge-weighted graph, the network.

GİRİŞ

Matematiğin bir dalı olan graf teori, günlük yaşamda karşılaşılan pek çok olayın matematiksel modellerinin oluşturulmasına ve bu modellerin bilinen yöntemlerden farklı başka tekniklerle kolayca çözülmesine olanak tanır. Matematiksel olarak ifade edilirse, $V(G)$ tepeler kümesi, $E(G)$ ayrıtlar kümesi olmak üzere $V(G)$ tepeler kümesindeki ikililerin ve bu ikililer arasındaki ayrıtların oluşturduğu yapıya graf adı verilir ve $G = (V, E)$ şeklinde ya da kısaca G ile gösterilir. Bir ayrıt $e = (u, v)$ biçiminde gösterilir. Burada u ile v tepelerine bitişik tepeler denir. Ayrıca e ayrıtı da u ve v tepesi ile bitişiktir. Bitişik tepeler komşu tepeler olarak da adlandırılır. (Dündar, P. , Balcı, M. A. ve Kılıç, E., 2011)

Bir G grafının tüm tepelerini tam olarak bir kez geçen başlangıç ve bitiş noktası aynı olan çevreye Hamilton çevre denir. Hamilton çevre içeren graflara Hamiltonian ya da Hamilton graf denir. Hamilton çevrede grafın tüm ayrıtlarının kullanılması gerekmemektedir. Bir grafın Hamilton graf olup olmadığına karar vermek çok zor olabilir. Hamilton çevrelerin belirlenmesine ilişkin ifadesi karmaşık ve uygulaması zor bir kaç gerek ve bir kaç yeter şart bulunmakla birlikte hali hazırda bir grafın Hamilton graf olup olmadığını söyleyecek bir gerek ve yeter şart bilinmemektedir. (Xu, J., 2003)

Temel Tanımlar

Tanım: $G = (V, E)$ grafının ayrıtlarına (tepelere) ortak bir birim ortamında değerler yerleştirilirse böyle graflara ayrıt (tepe) ağırlıklandırılmış graf denir. (Gross, J. ve Yellen, J., 1998)
 $G = (V, E)$ grafı için W matrisi ağırlık matrisi olarak kullanılmakta ve elemanları $w_{ij} > 0$ ağırlıkları olup i tepesini j tepesine doğrudan birleştiren ayrıtın ağırlığı olarak tanımlanmaktadır. Eğer i tepesi j tepesine bir ayrıtla bitişik değilse $w_{ij} = \infty$ alınmaktadır ve graf loop (bir tepeyi kendisine bağlayan ayrıt) içermediğinden $w_{ii} = 0$ alınmaktadır.

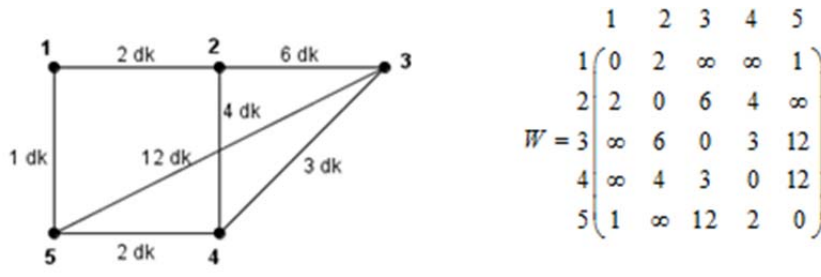

Şekil 1. Ayrıt-Ağırlıklandırılmış Graf ve Ağırlık Matrisi

Tanım: Bir G grafının bir v tepesine bağlı olan ayrıtların sayısına v tepesinin derecesi denir.

Gezgin Satıcı Problemi

Bir grafta minimum ağırlıklı Hamilton çevrenin bulunması problemi gezgin satıcı problemi olarak bilinmektedir. Bu problemde amaç, bir satıcının bulunduğu şehirden başlayıp her şehre sadece bir kez uğradıktan sonra başladığı şehre dönen en kısa turu bulmaktır.

Gezgin satıcı problemi, graf teorii dilinde şehirlerin tepelerle şehirler arası yolların ayrıtlarla temsil edildiği bir graf üzerinde en kısa Hamilton turunun bulunmasıdır. Eğer graf Hamilton graf ise böyle bir kapalı yol vardır. Bu durumda gezgin satıcı probleminin çözümü Hamilton çevrenin bulunmasıyla aynıdır. Ancak graf Hamilton grafi olmayabilir. Bu durumda problem graf üzerinde Hamilton çevrenin varlığının araştırılması veya Hamilton çevrenin olması için grafa yapılacak eklemenin (ayrıt) nerelere olacağıdır. Gezgin satıcı probleminin Hamilton çevreden farkı gezinmenin en az maliyetle yapılmasıdır. (Davendra, D., 2010 ; Dündar, P. ve Dündar, S., 1998)

Gezgin Satıcı Probleminin Matematiksel İfadesi

$V = \{1, 2, \dots, n\}$ tepeler kümesi, $E = \{(i, j) | (i, j) \in V, i \neq j\}$ ayrıtlar kümesi olmak üzere genel olarak n tepeli m ayrıtlı bir G grafi üzerindeki minimum ağırlıklı Hamilton çevre probleminin genel doğrusal programlama problemi aşağıdaki gibidir:

a. Graf yönlü graf ise,

$$x_{ij} = \begin{cases} 1, & (i, j) \text{ ayrıtı seçilirse} \\ 0, & \text{aksi halde} \end{cases} \quad (1)$$

$$\begin{cases} \sum_{\substack{i=1 \\ i \neq j}}^n x_{ij} = 1, & j = \overline{1, n} \\ \sum_{\substack{j=1 \\ i \neq j}}^n x_{ij} = 1, & i = \overline{1, n} \end{cases} \quad (2)$$

$$\sum_{(i,j) \in S} x_{ij} \leq |S|, \quad 2 \leq |S| \leq n-2, \quad S \subseteq V \quad (3)$$

$$z = \sum_{j=1}^n \sum_{i=1}^n w_{ij} x_{ij} \quad (4)$$

b. Graf yönsüz graf ise,

$$x_{ij} = \begin{cases} 1, & (i, j) \text{ ayrıtı seçilirse} \\ 0, & \text{aksi halde} \end{cases} \quad (1)$$

$$\sum_{i < k}^n x_{ij} + \sum_{j > k}^n x_{ij} = 2, \quad k = \overline{1, n} \quad (2)$$

$$\sum_{(i,j) \in S} x_{ij} \leq |S|, \quad 3 \leq |S| \leq n-3, \quad S \subseteq V \quad (3)$$

$$z = \sum_{j=1}^n \sum_{i=1}^n w_{ij} x_{ij}, \quad i < j \quad (4)$$

Amaç (4) deki fonksiyonun değerini (1), (2) ve (3) koşulları altında minimum yapmaktır. (2) koşulu her tepede bir giren ve bir çıkan ayrıntı bulunduğunu gösterir. Yani Hamilton çevrede her tepenin derecesinin 2 olduğunu gösterir. (3) koşulu ise oluşacak erken Hamilton alt turlarının yok edildiğini gösterir. (Jain, L. ve Bhanot, A., 2012)

YÖNTEM

En Kısa Uzunluklu Hamilton Çevrelerin Bulunması Algoritması

Aşağıdaki çözüm yöntemini izleyerek gezgin satıcı problemi için üç adımlık bir çözüm yolu geliştirilebilir.

- (a) Grafın tüm Hamilton turlarını bul.
- (b) Her turun uzunluğunu hesapla.
- (c) Turlar arasından en kısasını seç.

Eğer satıcı 25 şehirli bir gezgin satıcı problemini her Hamilton turunu 10^{-9} saniye inceleme kapasitesine sahip bir bilgisayarla çözmeye kalkarsa 10 milyon yıl sonra en kısa turu bulabilir. Böylece bu çözüm yolunun uygulanması olanaksızdır.

Çok şehirli gezgin satıcı problemlerini çözmek için pratik bir yöntem, yaklaşık çözüm üreten sezgisel algoritmalar kullanmaktır. Sezgisel algoritmalar, en iyi çözümü garanti etmemelerine karşın en iyi çözüme yakın oldukça iyi bir sonucun makul bir sürede bulunmasını sağlarlar. Sezgisel algoritmalarından bir tanesi de en yakın komşu algoritmasıdır. (Nabiyev, V.V., 2013)

En Yakın Komşu Algoritması

En yakın komşu algoritması her adımda minimum ağırlığın seçimine dayalı olan bir algoritmadır. Bu algoritma oldukça hızlı ve uygulanması kolay bir algoritmadır. Fakat başlangıç tepesinin seçimine bağlı olarak gerçek çözüme yaklaşıldığı gibi uzaklaşmak ta mümkündür. (Gross, J. ve Yellen, J., 1998; Nabiyev, V.V., 2013)

Adım 1. İşlemlerin başlayacağı ve tamamlanacağı herhangi bir tepe seçilir. ($v = 1$)

Adım 2. Bu tepeden erken döngü oluşturmayacak şekilde minimum ağırlıklı komşu tepe seçilir.

Adım 3. $v = v + 1$ yap. Tüm tepeler ziyaret edilene kadar işlem tekrarlanır.

Adım 4. $|V| = n$ ise son ziyaret edilen tepeyle ilk tepe birleştirilir ve sonuç elde edilir.

BULGULAR

Ege Üniversitesi Kampüs Ağında En Kısa Uzunluklu Hamilton Çevrelerin Bulunması Problemi

Bu bölümde Ege Üniversitesinin doğu kampüsü krokisine bağlı kalınarak, duraklar arasındaki mesafeler kullanılarak en kısa uzunluklu Hamilton çevrelerin bulunması problemi için kampüsün grafi çizilmiştir.

Şekil 2' de krokisi verilen kampüs ağı bir graf olarak modellendiğinde Şekil 3' teki graf elde edilir. Bu modellemede durakların kesim noktası birer v_i tepesi ve sokaklar birer ayrıntıla belirlenmiştir. Her tepe arasındaki mesafeler ise ayrıntılar üzerine yerleştirilerek Şekil 3' teki 44 tepeli ayrıntı-ağırlıklandırılmış graf elde edilmiştir.

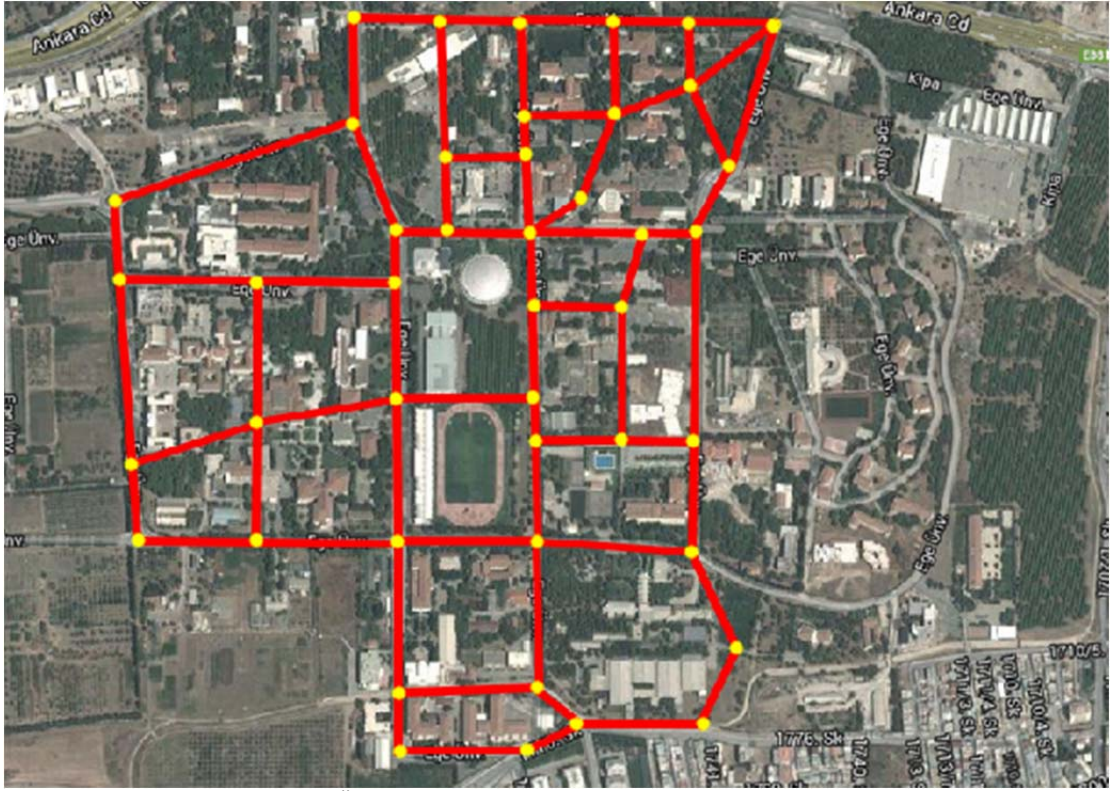

Şekil 2. Ege Üniversitesi Kampüsünün Doğu Yakasının Krokisi

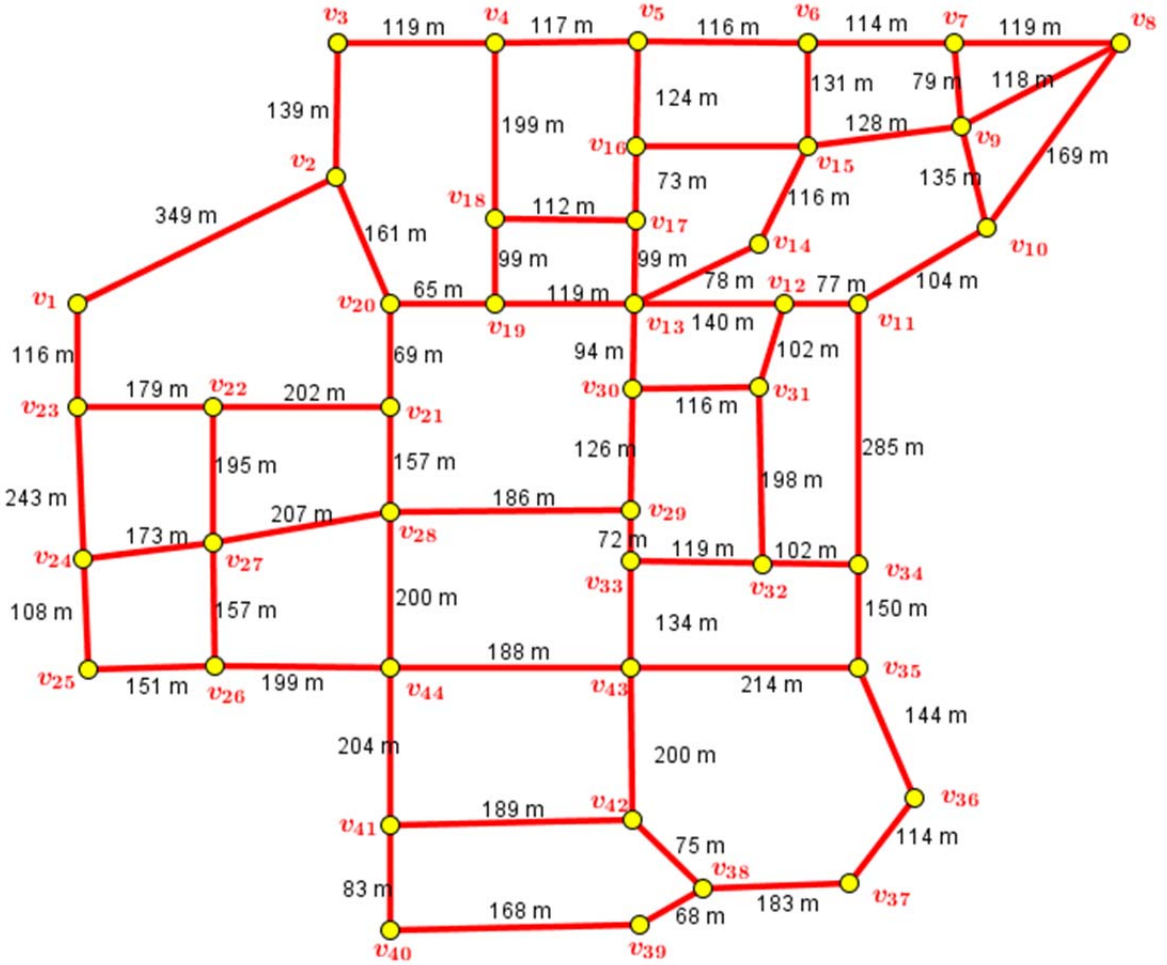

Şekil 3. Krokisi Verilen Ağın Grafi

En Yakın Komşu Algoritması Bazlı Gezgin Satıcı Problemi Algoritması

En yakın komşu algoritması bazlı bu algoritmada en yakın komşu algoritmasının çalışma mantığı esas alınarak, verilen problemin ağırlık matrisi üzerinden minimum ağırlıklı Hamilton çevreleri bulunması amaçlanmaktadır.

Adım 1. W ağırlık matrisinde işlemlerin başlayacağı ve biteceği bir v tepesi seçilir ve bu v tepesinin satırındaki sıfırdan farklı minimum ağırlıklı olan elemanın bulunduğu sütun tepesi etiketlenir. ($v = 1$)

Adım 2. v tepesinin satır ve sütun elemanları silinerek yerine sıfır yazılır.

Adım 3. $v = v + 1$ yap. Etiketlenen tepenin satırındaki en küçük elemanın sütun tepesi etiketlenir ve etiketlenen ilk tepenin satır ve sütun elemanları silinerek yerine sıfır değeri yazılır.

Adım 4. Eğer minimum ağırlık sonsuz veya sıfır ise adım 1'e git. Aksi halde adım 3'e git.

Adım 5. $|V| = n$ ve $W = [0]$ (ağırlık matrisi sıfır matris) ise son tepe ile ilk v tepesi birleştirilir ve sonuç elde edilir. Aksi halde adım 1'e git.

Verdiğimiz algoritmanın Matlab dilinde genel kodlaması yapılmış ve Şekil 3' de oluşturulan 44 tepeli grafin ağırlık matrisi oluşturulup verilen algoritma bu matrise göre çalıştırılmıştır. Sonuç olarak 21 tane minimum ağırlıklı Hamilton çevre bulunmuştur. Bulunan Hamilton çevrelerin birkaçı ve uzunlukları aşağıda verilmektedir.

v_2 tepesi ile başlayan en kısa uzunluklu Hamilton çevre:

$v_2 - v_3 - v_4 - v_5 - v_6 - v_7 - v_9 - v_8 - v_{10} - v_{11} - v_{12} - v_{31} - v_{30} - v_{13} - v_{14} - v_{15} - v_{16} - v_{17} - v_{18} - v_{19} - v_{20} - v_{21} - v_{28} - v_{29} - v_{33} - v_{32} - v_{34} - v_{35} - v_{36} - v_{37} - v_{38} - v_{39} - v_{40} - v_{41} - v_{42} - v_{43} - v_{44} - v_{26} - v_{25} - v_{24} - v_{27} - v_{22} - v_{23} - v_1 - v_2$

v_2 tepesi ile başlayan en kısa uzunluklu Hamilton çevrenin uzunluğu 5786 m 'dir.

v_3 tepesi ile başlayan en kısa uzunluklu Hamilton çevre:

$v_3 - v_4 - v_5 - v_6 - v_7 - v_9 - v_8 - v_{10} - v_{11} - v_{12} - v_{31} - v_{30} - v_{13} - v_{14} - v_{15} - v_{16} - v_{17} - v_{18} - v_{19} - v_{20} - v_{21} - v_{28} - v_{29} - v_{33} - v_{32} - v_{34} - v_{35} - v_{36} - v_{37} - v_{38} - v_{39} - v_{40} - v_{41} - v_{42} - v_{43} - v_{44} - v_{26} - v_{25} - v_{24} - v_{27} - v_{22} - v_{23} - v_1 - v_2 - v_3$

v_3 tepesi ile başlayan en kısa uzunluklu Hamilton çevrenin uzunluğu 5786 m' dir.

v_{32} tepesi ile başlayan en kısa uzunluklu Hamilton çevre:

$v_{32} - v_{34} - v_{35} - v_{36} - v_{37} - v_{38} - v_{39} - v_{40} - v_{41} - v_{42} - v_{43} - v_{33} - v_{29} - v_{30} - v_{13} - v_{14} - v_{15} - v_{16} - v_{17} - v_{18} - v_{19} - v_{20} - v_{21} - v_{28} - v_{44} - v_{26} - v_{25} - v_{24} - v_{27} - v_{22} - v_{23} - v_1 - v_2 - v_3 - v_4 - v_5 - v_6 - v_7 - v_9 - v_8 - v_{10} - v_{11} - v_{12} - v_{31} - v_{32}$

v_{32} tepesi ile başlayan en kısa uzunluklu Hamilton çevrenin uzunluğu 5834 m' dir.

Bulunan 21 Hamilton çevre içinden en kısa uzunluklu Hamilton çevrenin uzunluğu 5786 m' dir.

SONUÇ

Bu çalışmada Ege Üniversitesi kampüsünün doğu yakası krokisi ele alınarak kampüsün grafi çizilmiş ve bir öğrencinin bir duraktan başlayarak tüm duraklara tam bir kez uğrayıp başladığı durağa dönecek şekilde minimum uzunluklu bir tur yapıp yapamayacağı verilen algoritma ile incelenmiş ve Hamilton çevrelerin uzunlukları hesaplanıp bunlar içinden en kısa olanı bulunmuştur.

KAYNAKLAR

- Davendra, D. (2010). *Traveling salesman problem, theory and applications*. India: InTech.
- Dündar, P. & Dündar, S. (1998) Zincir yapılı gezgin satıcı probleminin çözümü için dinamik bir algoritma. *Yöneylem araştırma ve endüstri Mühendisliği XIX. Kongresi*, ODTÜ. Ankara.
- Dündar, P. & Balcı, M.A. & Kılıç, E. (2011) Bir kampüs ağında acil telefonları yerleştirilmesi probleminin matematiksel modellenmesi. *DEÜ Mühendislik Bilimleri Dergisi*. 13 (1), 1-8.
- Gross, J. & Yellen, J. (1998). *Graph theory and its applications*. New York, NY: Crc Press.
- Jain, L. & Bhanot, A.(2012) Travelling salesman problem: A case study. *International Journal of Computers & Technology*, 3 (1), 167-169.
- Nabiyev, V.V. (2013) *Teoriden uygulamalara algoritmalar*. Ankara. Seçkin.
- Xu, J. (2003) *Theory and application of graphs*. USA: Kluwer Academic Publisher.

PSEUDOSCIENTIFIC BELIEFS OF UNIVERSITY SCIENCE EDUCATION STUDENTS

Duygu METIN

Jale CAKIROGLU

Ceren OZTEKIN

Yasemin OZDEM

Kader BILICAN,

The development of scientific literacy is fundamental goal of every country. According to Hurd (1998), distinguishing theory from dogma, understanding the ways in which scientific research is done, and distinguishing science from pseudo-science such as astrology are some skills characterizing scientific literate individual. For this reason, the existence of pseudoscientific beliefs would be stated as fundamental obstacle to developing scientific literacy. However, consistent evidence are available showing that pseudoscientific beliefs are widespread among general population, students, and even among science educators (Martin, 1994).

Although science and pseudoscience seem to have some similarities, they are absolutely different from each other in their assumptions, process, and context. Shermer (1997) explained pseudoscience as claims that they appear scientific although they lack supporting evidence and plausibility. Investigating pseudoscientific beliefs is a newly emerging research field in Turkey, and research studies held in pseudoscience are very limited.

The purpose of the present study was to investigate university science education students' pseudoscientific beliefs. Participants were 1805 university students attending science teacher education program in 16 different universities across Turkey. The methodology of the study is survey. Pseudoscientific Belief Scale and some demographic questions were used to collect data. Pseudoscientific Belief Scale includes four factors that are Superstitions, Paranormal Beliefs, Socio-cultural Beliefs Related to Religion, and Pseudoscientific Beliefs.

The results showed that university science education students believe in superstition stated in scale such as broken mirror, black cat, and unlucky numbers. They had beliefs based on religious ritual such as wearing amulet, and going to religious places before an important issue such as exam. They also had some pseudoscientific beliefs such as "the solar eclipse triggers an earthquake". The mode values of the most of the items are 5 indicating the students were absolutely agree about most of the pseudoscientific beliefs.

Keywords: pseudoscientific beliefs, science education

THE EFFECTS OF MODEL BASED TEACHING ON 8th GRADERS' METACOGNITIVE AWARENESS AND ATTITUDES TOWARDS SCIENCE AND TECHNOLOGY COURSE: EXAMPLE OF SOUND UNIT

Gül ÜNAL ÇOBAN
Dokuz Eylul University, Buca Education Faculty
gul.unal@deu.edu.tr

Gonca SOLMAZ
Atatürk Orta Okulu
goncasolmaz83@gmail.com

Merve KOCAGÜL
Dokuz Eylul University, Buca Education Faculty
merve.kocagul@deu.edu.tr

ABSTRACT: The aim of this study is to examine the effects of model based teaching on students' metacognitive awareness and attitudes towards science and technology course. In this context, fifty eight 8th graders attending to a state middle school in one of the districts of İzmir participated in the study. The model of the study is pre test post test with control group quasi experimental design. Students were randomly assigned to experimental and control groups. In this 4-week study, the experimental group received model based science activities related to sound unit and the control group received activities in the same unit in consistent with the present Turkish Science and Technology Curriculum which was being used since 2005. Data were gathered through "Metacognition Scale", "Attitudes towards Science and Technology Scale" and open ended questions for determining the metacognitive processes of students. Data were analyzed through statistical packet programs and content analysis. The quantitative results obtained from the research showed that the model based sound activities have no significant difference on students' metacognitive awareness and attitudes towards science and technology course. Analysis of qualitative data obtained from the research is still continuing.

Key words: Model-based teaching, Metacognitive awareness, Attitudes toward science and technology course.

STUDENTS' INTERNET AND WEB 2.0 USE: A CASE OF BURDUR'S MIDDLE SCHOOLS

Vesile Gül BAŞER GÜLSOY
Mehmet Akif Ersoy University
vesilegulbaser@gmail.com

Berrin DOĞUSOY TAYLAN
Mersin University
berrindogusoy@gmail.com

İlker YAKIN
Mersin University
yakinilker@gmail.com

ABSTRACT: This study focused on students' use of Internet and web 2.0 technologies for general and educational uses in terms of gender, technologies ownership, Internet connection, Internet and computer skills levels and years of use. 350 middle school students and two IT teachers were participated to the study. Descriptive data collected through a survey that designed by the researchers and based on these results, semi-structured interviews were conducted with their teachers. The results indicated that students with high confidence on computer and Internet use preferred to use social networking, video sharing and game sites than blogs, wikis e-mail services and cloud technologies like google drive for their general Internet and computer use. They use these technologies for homework and practice the previous content than communicating with their peers and teachers and also for educational games and educational videos. The findings obtained through teachers supports the data gathered from the students.

Key words: computer and Internet usage, web 2.0 technologies, middle school

INTRODUCTION

Technological developments providing countless opportunities for communication have allowed people to present their ideas and exchange information from different location and time zone. Both the Internet and web 2.0 technologies presents many different features for the users. Today people not only reach information from different sources but also create and share their own works, contribute others works via using blogs, forum, wikis. The growing interest on online social networks created a different platform for people to collaborate and communicate. Web 2.0 technologies provides users interactive services (Ajjan, & Hartshorne, 2008) giving user the opportunity to interact with content and other users. Wikis, blogs, instant messaging and social networking sites are widely used Web2.0 technologies to achieve those utilities. These technologies changes the way of creating using sharing and also distributing any types of documents. Users creates Wikis (What I know Is) by interacting content via adding, removing, or editing. The mostly used *Wikis* is the Wikipedia with rich sources of information in different languages. *Blogs* can be defined as the personal journals with content, and images about different content and topic open to access and interaction with the followers. Users can create their own profile and connect with other users with Social *networking* sites. Facebook, Twitter, and Instagram are the mostly known social networking sites. These sites provide users to post different kinds of documents, make organizations follow their friend.

This attractive feature of information and communication technologies (ICT) draws people attention from different ages and work areas. Education is one of these areas; and nations focus on developing literate youths in the 21 century skills. For the requirements of the information age, creativity, critical thinking, communication and collaboration, information, media and ICT literacy hold an important place (Kay, 2009). These skills are needed in order to build deep and interdisciplinary understanding of knowledge and problem related to the real world. Developing such qualifications in the early years of education where teachers and students use technology in their learning and teaching processes is so important to rise new generation to cope with the different requirements highlighted with the information age period. The researchers discussed that the use of ICT might provide practical solutions for educational needs (Pierce, 2009). In addition, the research results reveal that the positive effects of ICT related activities while developing 21 century skills including critical thinking, problem solving (Özdemir & Kılıç, 2007) higher order thinking skills (Çavaş & Çavaş, 2005; McMahon, 2009), and information searching skills (Çalışkan & Turan, 2008; Ersoy & Türkkan, 2009; Yılmaz & Aydın, 2013).

Since the use of ICT's including computers, laptops, smart phones and Internet rate is gradually growing, it was aimed to understand the views of the students and teachers regarding the Internet and Web 2.0 technologies in their daily usage and in educational platforms. This study may contribute to the literature for not only understanding the views of the students and IT teachers but also the potential of the web 2.0 technologies for informal learning opportunities.

METHODS

In this study a mixed approach was used to explore the views of the middle school students and teachers about the use of Internet and Web 2.0 technologies for general and educational purposes. Quantitative data were collected to have an understanding about the students' views and for having in depth understanding related with teachers views' qualitative data were collected (Creswell, 2011). Descriptive statistics for quantitative data and content analysis for qualitative data were selected as analysis methods for the study. The sample of the study was selected from the middle schools in Burdur province, where information technologies and software courses are given. The participants were 350 middle school students and two IT teachers from the two middle schools. All students were enrolled to Information Technologies and software course before the data collection process. While selecting the sample, two middle schools selected out of 5 as the samples of the study by using cluster sampling method. Moreover, two Information Technologies and software course teacher from the same schools were participated to the study to have deeper information about their views on Web 2.0 technologies and usage at school.

Instruments and Data analysis

The questionnaire which was developed by the researchers consisting of 27 questions and four subsections related with the views of the participants. In the first subsection, questions related with the demographics of the students, their parents' education levels, and their access to a technological device and the Internet and their use of experience with computer and Internet were asked. Other subsections were respectively; computer and Internet usage skills; Internet usage frequency, frequency of using the ICT for educational purposes. In the questionnaire, there were nineteen five scale Likert type questions from "never" to "always". In order to have in depth understanding and detailed information regarding the views of the teacher, six semi-structured interview questions were asked to the IT teachers. The descriptive data were analyzed by using SPSS 20 and qualitative data were analyzed by using content analysis technique.

RESULTS AND FINDINGS

Descriptive Statistics

The demographics of the students are depicted in Table 1. As seen from the Table 1, the participants in this study were 43.7% male and 56.3% female. The grade levels of the participants were 43.1% of them 5th grade, while 56.9% of the participants were 6th grade levels. Participants' access to the technological devices were explored and the results showed that most of the participants (95.7%) have access to the computer while 42.3% of the participants also have smart phones and 39.4% of them have a chance to use tablets at their home. Moreover, it was found that majority of the students (89.7%) have Internet access at their computers, while 34.4% of them have Internet access at their smart phones and 31.1% of them have at their tablets. Most of the participants (66.6%) declared that they were using computer more than 4 years while half of the participants (50%) expressed that they have been using Internet more than 4 years. Table 1 presents the characteristics of the students and computer and Internet experience of the students in terms of the time periods.

Table 1. Characteristic of the Students

		N	%
Gender	Female	197	56.3
	Male	153	43.7
Grade level	5th	151	43.1
	6th	199	56.9
Preschool education	Yes	308	88.0
	No	32	9.1
Accessing a technological device at home	Computer	335	95.7
	Tablet	138	39.4

Connecting Internet via	Smart phone	148	42.3
	Computer	314	89.7
	Tablet	109	31.1
	Smart phone	121	34.6
Years of Computer Use	0-1 year	10	2.9
	1-2 years	11	3.1
	2-3 years	25	7.1
	3-4 years	69	19.7
	More than 4 years	233	66.6
	Years of Internet Use	0-1 year	23
1-2 years		22	6.3
2-3 years		47	13.4
3-4 years		74	21.1
More than 4 years		175	50.0

Additionally, the educational level of the participants' parents was also explored. The results showed that 30.3% of the mothers were graduated from high schools, while 23.1% of them were graduated from university and 21.1% of them graduated from middle school. As for fathers, however, 37.2% of them were graduated from university and 31.5% of them were graduated from high schools. Table 2 presents the educational level of the participants' parents.

Table 2. Parent Education Level

Parent education level	Mother		Father	
	<i>N</i>	%	<i>N</i>	%
Illiterate	4	1.1	5	1.4
Literate	11	3.1	9	6.6
Primary school	50	14.3	23	6.6
Middle school	74	21.1	34	9.7
High school	106	30.3	110	31.5
University	81	23.1	130	37.2
Master	23	6.6	38	10.9

Moreover, participants' computer and Internet usage skills were examined in the study. The results showed that most of the participants (41.4%) expressed their computer usage skills as "*I know well*" while 37.1% of them responded this question as "*I know very well*". On the other hand, a reverse situation was occurred for Internet usage skills. Majority of the participants (47.1%) declared themselves for Internet usage skill as "*I know very well*" while 33.7 % of them responded this question as "*I know well*". These students' responds clarified by one of their teachers with the following quotation: "...*They [students] have a chance to use PCs at their home anymore. Moreover, they have also smartphones and tablets. That is why the utilization of the Internet is widespread – affecting up the computer and the Internet usage...*" Table 3 represents the computer and Internet usage skills of the students.

Table 3. Computer and Internet usage skills

	I don't know		I know a little		I know		I know well		I know very well	
	<i>N</i>	%	<i>N</i>	%	<i>N</i>	%	<i>N</i>	%	<i>N</i>	%
Computer	3	0.9	23	6.6	48	13.7	145	41.4	130	37.1
Internet	2	0.6	18	5.1	43	12.3	118	33.7	165	47.1

Participants were also asked about their frequency of their Internet usage for different applications. The results showed that participants expressed that they "*always*" use social media like "Facebook" and "Twitter" (54.6%) and "YouTube" (53.4%). On the other hand, according to their responses they "*never*" use wikis (60.9%) and blogs (58%) in their daily Internet activities. For this issue, one of the teachers highlighted the fact that students do not have knowledge about these tools because they will learn how to use wikis and blogs later. In table 4 the results obtained from the survey were presented related with the Internet usage frequency of the participants.

Table 4. Internet Usage Frequency

Never	Rarely	Occasionally	Usually	Always
-------	--------	--------------	---------	--------

	<i>N</i>	<i>%</i>	<i>N</i>	<i>%</i>	<i>N</i>	<i>%</i>	<i>N</i>	<i>%</i>	<i>N</i>	<i>%</i>	<i>M</i>
News portal	99	28.3	98	28.0	93	26.6	39	11.1	17	4.9	2.36
Game sites	8	2.3	30	8.6	96	27.4	112	32.0	103	29.4	3.78
Chat / friendship sites	53	15.1	43	12.3	64	18.3	88	25.1	102	29.1	3.41
E-mailing services	78	22.3	87	24.9	74	21.1	57	16.3	51	14.6	2.76
Wikis	213	60.9	51	14.6	25	7.1	23	6.6	32	9.1	1.98
Blogs	203	58.0	65	18.6	28	8.0	25	7.1	26	7.4	1.86
Google drive	79	22.6	57	16.3	65	18.6	64	18.3	80	22.9	3.03
Social media (Facebook/ Twitter)	34	9.7	20	5.7	43	12.3	61	17.4	191	54.6	4.02
YouTube	15	4.3	19	5.4	49	14.0	78	22.3	187	53.4	4.33

When participants' frequency of Internet and communication technologies use for educational purposes were examined, most of the participants expressed that they "always" use ICT for finding sources for finding sources to prepare homework (46.3%), doing their homework (46%) and drill & practice applications and solving problems (37.1%). They also declared that they "always" use ICT for preparing presentations (38.3%) and communicating with their friends for doing homework (23.7%). The following quotation from an interview with a teacher clarified this: "...All teachers want students to prepare their homework via using computers. Students might communicate their friends to cope with these assignments..." Table 5 represents participants' frequency of Internet and communication technologies use for educational purposes.

Table 5. Frequency Of Internet And Communication Technologies Use For Educational Purposes

	Never		Rarely		Occasionally		Usually		Always		<i>M</i>
	<i>N</i>	<i>%</i>	<i>N</i>	<i>%</i>	<i>N</i>	<i>%</i>	<i>N</i>	<i>%</i>	<i>N</i>	<i>%</i>	
Finding sources for preparing homework (visual, audio, written sources)	3	0.9	12	3.4	44	12.6	129	36.9	162	46.3	4.24
Communicating with friends for preparing homework	26	7.4	50	14.3	110	31.4	81	23.1	83	23.7	3.41
Communicating with teachers for preparing homework	93	26.6	90	25.7	74	21.1	48	13.7	41	11.7	2.57
Doing homework	1	0.3	7	2.0	48	13.7	129	36.9	161	46.0	4.27
Prepare presentation	10	2.9	26	7.4	82	23.4	97	27.7	134	38.3	3.91
Watching educational videos	39	11.1	96	27.4	72	20.6	69	19.7	74	21.1	3.12
Reading e-book	115	32.9	52	14.9	70	20.0	50	14.3	60	17.1	2.68
Playing educational games	56	16.0	68	19.4	89	25.4	65	18.6	70	20.0	3.07
Making experiments	66	18.9	90	25.7	81	23.1	61	17.4	51	14.6	2.83
Drill and practice/ solving questions	15	4.3	39	11.1	63	18.0	103	29.4	130	37.1	3.84

CONCLUSION

This study explored the views of the middle school students and teachers about the use of Internet and Web 2.0 technologies for general and educational purposes. The results showed that participants mostly preferred to use social media and YouTube instead of the other Internet sources. This finding supports the general idea that user-generated content is successful only if users are regularly attracted to the website to contribute (Rennie, & Mason, 2007). Students also expressed that they "never" use wikis (60.9%) and blogs (58%) in their daily Internet activities. The Global Information Technology Report (2014) investigated the uses of virtual social networks (e.g., Facebook, Twitter, LinkedIn) among countries (Osorio, Dutta, & Lanvin, 2014). According to the report, Turkey was ranked as 61st and accepted as social networks have been widely used country in the list (p.298). Moreover, Şener (2009) explored the profile of Facebook users in Turkey. She found that the usage of Facebook varied according to the gender, socio economic situation and age. The user group in Turkey consider Facebook as an environment which provides chance to communicate with their friends. According to Ellison, Steinfield and Lampe (2007), college students in the U.S. used Facebook for social interaction offline to communicate with their existing friends and strengthen their relationships with them. In addition, the reasons for not preferring to use wikis and blogs might be related with the one way interaction nature of them. In addition, this intensive interest to the Facebook and Youtube and contrary interest to wikis and blogs might be related with the cultural background of Turkey. As Şener (2009) indicated Turkish people using Facebook mostly for communicating possibilities. Moreover, the flexibility of Facebook regarding the communication possibilities might also be another reason for their high demands.

Moreover, participants' responses to the questions regarding frequency of using ICT technologies for educational purposes showed that they tended to use ICT technologies respectively, for finding sources for

preparing homework, doing their homework and drill and practice applications or solving problems. The results showed that they use ICT for preparing presentations and communicate with the other friends while doing their homework. Yılmaz and Aydın (2013) in their qualitative study presented the middle school students positive predisposition towards technology due to its benefit to their course works, personal growth, information search and spending time for fun.

When the education levels of the parents were examined, there might be a relation between the education level and their socio-economic levels. The more educated and high income families have chance to provide more technological devices to their children. This might also affect the view of the children directly, the more they acquainted with the technology the more their views will be positive. This situation should also be investigated through the further studies to explore exact correlation between these variables. The results also point out that the students' computer and the Internet competencies differ slightly. The difference between the self-evaluation of the participants regarding their computer and the Internet skills might be related with the Internet usage by using smart phones. The demographics also showed that a non-negligible part of the students have Internet access in their smart phones. Therefore, we need new research studies on understanding how this discrepancy might be handled with regard to educational utilization of the computer and the Internet.

REFERENCES

- Ajjan, H., & Hartshorne, R. (2008). Investigating faculty decisions to adopt web 2.0 technologies: Theory and empirical tests. *The Internet and Higher Education*, 71-80.
- Creswell, J.W. (2011). *Educational Research: Planning, Conducting, and Evaluating Quantitative and Qualitative Research*. Sage Publications. 4th edition.
- Çalışkan, H., & Turan, R.(2008). Araştırmaya dayalı öğrenme yaklaşımının sosyal bilgiler dersinde akademik başarıya ve kalıcılık düzeyine etkisi. *Türk Eğitim Bilimleri Dergisi*, 6(4), 603-627.
- Çavaş, B., & Çavaş, P, H. (2005) Teknoloji tabanlı öğrenme: robotics club". *Akademik Bilişim* , 2-4 Şubat, 2005. (<http://ab.org.tr/ab05/tammetin/59.pdf>)
- Ellison, N. B., Steinfield, C., & Lampe, C. (2007). The benefits if facebook" friends": Social capital and college students' use of online social network sites. *Journal of Computer Mediated Communication*. 12(1143-1168)
- Ersoy, A., & Türkkan, B. (2009). İlköğretim öğrencilerinin resimlerinde Internet algısı. *İlköğretim Online*, 8(1), 57-73.
- Kay, K. (2009, September). P21 framework definitions. *Partnership for 21st Century Skills*: Retrieved from (http://www.p21.org/storage/documents/P21_Framework_Definitions.pdf) on 18th April 2014.
- McMahon, G. (2009). Critical Thinking and ICT Integration in a Western Australian Secondary School. *Educational Technology & Society*, 12 (4), 269–281.
- Osorio, B.B., Dutta, S, & Lanvin, B. (2014). The Global Information Technology Report: Rewards and Risks of Big Data. Retrieved from (http://www3.weforum.org/docs/WEF_GlobalInformationTechnology_Report_2014.pdf)
- Özdemir, S. & , Kılıç, E. (2007). Integrating information and communication technologies in the Turkish primary school system. *British Journal of Educational Technology*, 38 (907-916).
- Pierce, T. (2009). Social anxiety and technology: Face-to-face communication versus technological communication among teens. *Computers in Human Behavior*, 25(1367-1372).
- Rennie, F., & Mason, R. (2007). Using web 2.0 for learning in the community. *The Internet and Higher Education*, 10(196-203).
- Şener, G. (2009). Türkiye'de facebook kullanımı araştırması. Inet-TR-XIV. Türkiye'de İnternet Konferansı Bildirileri. Retrieved from (http://inet-tr.org.tr/inetconf14/kitap/sener_inet09.pdf)
- Yılmaz, Ş., & Aydın, F. (2013). Investigation of middle-school students' attitudes toward technology and factors affecting the attitudes. *Asian Journal of Instruction*, 1(2), 1-17.

FEN VE MATEMATİK ÖĞRETMEN ADAYLARININ “EŞİTLİK, EŞİTSİZLİK, DENKLİK, DENKLEM, ÖZDEŞLİK” KAVRAMLARINA İLİŞKİN ALGILARI

THE PERCEPTIONS OF SCIENCE AND MATHEMATICS TEACHER CANDIDATES TOWARDS THE CONCEPTS OF “EQUALITY, INEQUALITY, EQUIVALENCE, EQUATION, IDENTITY”

Emre EV ÇİMEN
Eskişehir Osmangazi Üniversitesi
evcimen@ogu.edu.tr

Kürşat YENİLMEZ
Eskişehir Osmangazi Üniversitesi
kyenilmez@ogu.edu.tr

ÖZET: Yapılan çalışmalar öğrencilerin bir kısım cebirsel kavramları birbirleri ile karıştırdıkları; pek çok cebirsel kavram ve yöntem hakkında ortak hatalar ve temel yanlışlar taşıdıklarını göstermektedir. Bunlar arasında matematiğin temel kavramlarından olan “eşitlik, eşitsizlik, denklik, denklem ve özdeşlik” öğrenciler tarafından çoğunlukla birbirleri ile karıştırılmakta, yanlış algılanmakta ve yanlış yorumlanmaktadır. Bu kavramlar fen ve matematik öğretiminde pek çok konu ve kavrama kaynaklık etmektedir ve her biri ilk ve ortaöğretim matematik öğretim programında önemli bir yere sahiptir. Bu bağlamda, bu araştırma öğretmen adaylarının birbirleri ile ilişkili söz konusu beş kavrama ilişkin algılarını betimlemeye yönelik nitel bir çalışma olup özel durum çalışmasıdır. Araştırma genelleme amacıyla değil genele ışık tutma amaçlı yapılmıştır. Araştırmanın örneklem grubu 64 Fen Bilgisi, 60 İlköğretim Matematik olmak üzere toplam 124 öğretmen adayından oluşmaktadır. Araştırmada her bir kavrama ilişkin öğretmen adaylarının görüşleri alınmış ve verilerin analizinde içerik analizi uygulanmıştır. Elde edilen veriler kavramların doğru algılanıp algılanmadığı ve hangi kavramla karıştırıldığı yönü ile incelenmiştir. Sonuçlar öğretmen adaylarından seçilen örnek ifadelerle birlikte sunulmuştur.

Anahtar sözcükler: fen/matematik öğretmen adayları, cebirsel kavramlar.

ABSTRACT: Studies show that students confuse algebraic concepts with each other, make common mistakes and have fundamental misconceptions about many algebraic concepts and methods. The concepts of “equality, inequality, equivalence, equation and identity” that are among the fundamental concepts of mathematics are usually confused with each other, misperceived and misinterpreted by students. These concepts form the basis of many concepts and subjects in science and mathematics education and they have an important place in primary and secondary mathematics education curriculum. In this context, this research is a qualitative study aimed to describe teacher candidates' opinions about these five interrelated concepts and is a special case study. The research was not done to make any generalization but rather was done to shed some light on the general. The research sample group consist of 64 science teacher candidates and 60 elementary mathematics teacher candidates, totalling 124 candidates. In the research, teacher candidates' opinions about each concept were taken by interview for analysis and then content analysis method was applied. The data obtained after analysis were examined according to whether the underlined concepts are perceived correctly or not and which concept was confused with which other concept. The results were presented with some selected opinions of teacher candidates.

Key words: science/mathematics teacher candidates, algebraic concepts.

THE INVESTIGATION OF PRESERVICE TEACHERS' MEDIA AND TECHNOLOGY USAGE AND ATTITUDES

Ilker YAKIN

Vesile Gul BASER GULSOY

Berrin DOGUSOY TAYLAN

Advances in information and communication technologies have dramatically altered the way people do their daily tasks and the way their personal usage of technology-based activities are managed. Therefore, measuring recent technology and media behaviors has received a great amount of attention from researchers and practitioners in the area of education. This descriptive study aims to explore preservice teachers' technology and media usage and attitudes. The online questionnaire was administered to students from CEIT (Computer Education and Instructional Technology) department from a state university in Turkey. The questionnaire includes two sections; the first part consists of 42 items with 10 point frequency scale, and the second part includes 16 items with 5 point-likert type scale. The findings will be presented in the paper with eleven subheadings regarding smartphone usage, general social media usage, Internet searching, e-mailing, media sharing, text messaging, video gaming, online friendships, Facebook friendships, phone calling, and watching television in addition to four subheadings - positive attitudes, anxiety/dependence, negative attitudes, preference for task switching - with respect to attitudes towards technology. The results of the paper will be discussed with the recent research studies in the conclusion section. Lastly, some suggestions based on these findings will be also offered to conduct further studies and researches.

Keywords: Media and technology usage, Attitudes towards technology, preservice teachers

KESİRLER KONUSUNDAKİ KAVRAM YANILGILARI İLE İLGİLİ ÖĞRETMEN VE ÖĞRENCİLERDEN YANSIMALAR

REFLECTIONS FROM TEACHERS AND STUDENTS IN RELATION TO MISCONCEPTIONS ABOUT FRACTIONS

Yrd. Doç. Dr. M. Kerem KARAAĞAÇ
Marmara Üniversitesi
kerem.karaagac@marmara.edu.tr

Leyla KÖSE
Şehit Öğretmen Hamit Sütmen Orta Okulu
leyla_demiri@hotmail.com

ÖZET: Bu çalışmanın amacı öğretmen ve öğretmen adaylarının, öğrencilerin kesirler konusundaki kavram yanlışlarına ilişkin mevcut bilgilerini araştırmaktır. Araştırma, nitel araştırma yöntemlerinden çoklu durum (vaka) çalışması ile gerçekleştirilmiştir. Çalışma grubu bir üniversitenin İlköğretim Matematik Öğretmenliği Bölümünde son sınıfta okuyan 2 öğretmen adayından, ortaokullarda görev yapmakta olan 4 öğretmenden ve bir ortaokulun 7.sınıfında okuyan 90 öğrenciden oluşmaktadır. Veri toplama aracı olarak araştırmacı tarafından hazırlanan kavram yanlışları testleri kullanılmıştır. Öğretmen ve öğretmen adaylarına yarı yapılandırılmış mülakatlar uygulanmıştır. Araştırma sonucunda öğrencilerin büyük bir çoğunluğunun bir kesir ifadesindeki sayısal değer bütüne göre değişeceğinin yeterince kavrayamadığı bulunmuştur. Öğretmenlerin bu durumu öngörmesine rağmen kendilerine ait öğrencilerin bu kavram yanlışına düştükleri ortaya çıkmıştır. Ayrıca öğrencilerin bir kısmı kesirin ifade ettiği büyüklüğe karar verirken bütünü oluşturan parça sayısına veya parça büyüklüğüne göre karar vermiştir. Bu durum öğretmen ve öğretmen adaylarının öngöremediği bir kavram yanlışlığı olmuştur.

Anahtar sözcükler: Kavram yanlışlığı, Pedagojik Alan Bilgisi, Matematik Öğretmenleri, Öğretmen adayları

ABSTRACT: The purpose of this study is to explore teachers' and pre-service teachers' knowledge of students' misconception about fractions. As being a mainly qualitative research, this study has utilized multiple case study methodology. The cases consisted of 2 pre-service teachers who are in their senior year in primary mathematics education at a university, 4 in-service teachers working in a state school and 90 students. As a data collection tool misconception tests that were designed by the researcher have been utilized. Semi-structured interviews have also been conducted to collect in depth data from teachers and pre-service teachers. As result, students had misconceptions regarding the fact that the amount of 'part' indicated by a fraction is related to size of the 'whole'. An interesting finding was that the teachers had foreseen this and yet their student had such a misconception. In determining the amount of 'part' indicated by a fraction, some students decided solely on the basis of 'quantity of parts' or 'size of each part'. Neither pre-service teachers nor in-service teachers manage to foresee such a misconception.

Of a great majority of the students expressed a fraction of the numeric value will change by all has been grasped enough. Although the situation of teachers predict their own students that fall into these misconceptions have emerged. In addition, some students expressed a fraction of the numeric values in finding the number of constituent parts or parts that have been decided according to the size of teachers and student teachers did not foresee this situation has been a misconception.

Key words: Misconception, Pedagogical Content Knowledge, Mathematics Teachers, Pre-service Teachers

GİRİŞ

Kavram yanlışları farklı alanlarda birçok araştırmacının ilgisini çekmiştir. Çok sayıda araştırmacı aslında öğrencilerin bilgileri ezberlediklerini, başarılı öğrencilerin bile konuyu derinlemesine öğrenmedikleri sonucuna varmıştır. Özellikle fen bilimleri ve matematikte öğrencilerin soruları çözerken konuya hâkim olmadan, ezberden sadece formülde yerine koyarak çözdükleri sonuca varmışlardır (Yenilmez & Yaşa, 2008).

Matematik öğretiminde sadece işlemsel ve kurala dayalı bilgiye önem verilmemeli, bu bilginin temelini oluşturan kavramsal bilgi üzerinde de durulmalıdır (Küçük & Demir, 2009). Çünkü işlemler kavramlarla gerçekleşmektedir. Anlaşılamayan veya yanlış anlaşılan bu kavramlar da işlemlerin anlaşılabilir gibi algılanmasına sebep olmaktadır.

Öğrenciler, matematik dersindeki bir konuyu eksik veya yanlış öğrendiklerinde sorun yaşamakta ve bu sorun öğrencinin ilerleyen eğitim-öğretim hayatına yansımaktadır. Dolayısıyla öğrencinin üst öğrenmelerinde olumsuzluklar meydana gelmektedir. Bu olumsuzluklar giderilmediği sürece öğrencilerdeki eksik veya yanlış öğrenmeler birer kavram yanlışlığı haline dönüşmektedir (Yılmaz & Yenilmez, 2007).

Kavram yanlışlığı, zihinde bir kavramın yerine oturan fakat bilimsel olarak o kavramın tanımından farklı olması anlamına gelmektedir (Eryılmaz & Sürmeli, 2002).

Kavram yanlışlığı çalışmalarında en çok araştırma yapılan derslerden bir tanesi matematik dersidir. Bunda matematiğin soyut olmasından dolayı içinde birçok kavramı barındırmasının etkisi kaçınılmazdır. Matematiğin en soyut ve en zor anlaşılabilir konularından bir tanesi ise kesirler konusudur. Tam sayılardan farklı olarak kesirlerde çoklukların gösteriminde iki sayının birbirine göre ilişkisi ön plandadır. Kesirlerin bir başka özelliği de her bir kesir için sonsuz sayıda denk başka kesirlerin olmasıdır. Tam sayılarda ise her bir sayı tektir. Kesirler tam sayılardan farklı olarak referans aldığı bütüne göre değişik büyüklükleri gösterebilir. Kesirlerin karşılaştırılması tam sayılardaki gibi doğrudan değildir, birden fazla kavramı birlikte düşünmeyi gerektirir (Alacacı, 2010). Bu sebeple kesirler konusundaki öğrencilerin farklı şekillerde kavram yanlışlıklarına düştükleri görülmektedir. Öğrencilerin kesirler konusundaki kavram yanlışlıklarıyla ilgili çok sayıda çalışma olmasına rağmen; öğretmenlerin ve öğretmen adaylarının öğrencilerin kavram yanlışlıklarına ilişkin mevcut bilgisine yönelik araştırmaların yetersiz sayıda olduğu gözlemlenmiştir. Dolayısıyla öğretmenlerin ve öğretmen adaylarının, öğrencilerin kesirlerle ilgili kavram yanlışlıklarıyla alakalı mevcut bilgilerinin araştırılmasının bu konudaki boşluğun doldurulmasına katkıda bulunacağı sonucuna varılmıştır.

YÖNTEM

1) Araştırmanın Deseni

Öğretmen ve öğretmen adaylarının, öğrencilerin kesirler konusundaki kavram yanlışlıklarıyla ilgili mevcut bilgilerini incelemek amacıyla yapılan bu çalışmada nitel araştırma yöntemlerinden çoklu durum (vaka) çalışması ile gerçekleştirilmiştir.

2) Çalışma Grubu

Çalışma grubu pilot uygulama sonrası seçilen İstanbul ilindeki 4 farklı ilköğretim okulundaki 4 öğretmenden; bir üniversitenin son sınıfındaki 2 öğretmen adayından ve bir ilköğretim okulunun 7.sınıfında okuyan 90 öğrenciden oluşmaktadır. Öğretmenlerin tecrübesi 3-12 yıl arasında değişmektedir. Çalışmada öğretmen ve öğretmen adaylarının gerçek isimleri gizli tutulmuştur ve her biri için takma isimler kullanılmıştır. Öğrencilerin isimleri ise hiç kullanılmamıştır.

3) Veri Toplama Araçları

Bir kavram yanlışlığı testi oluşturmak için ilgili literatür taranmış ve Alacacı'nın (2010) çalışmasında yer alan kavram yanlışlığının üzerine oturtulduğu bileşenler temel alınarak test şekillendirilmiştir. Bu bileşenler şunlardır: Kesirlerde miktarın referans alınan bütüne bağlı olması; kesirlerin kısımlara ayrılması; kesirlerin karşılaştırılması; bileşik kesirlerde birimin belirlenememesi; kesrin hatalı toplanması; çarpmanın kesirlere etkisi; bölmenin kesirlere etkisi; kesrin yarısının nasıl elde edileceği. Uygulanacak test öğrencilere ve öğretmenlere - öğretmen adayları dahil- yapılan testler olmak üzere iki kısımdan oluşmaktadır. 18 sorudan oluşan kavram yanlışlığı testi pilot uygulamalar sonucunda öğrencilere uygulanmak üzere 9 soruya indirilmiştir. Öğretmenlere ve öğretmen adaylarına uygulanan kavram yanlışlığı testi ise öğrencilere uygulanan kavram yanlışlığı testleri uygun olacak şekilde değiştirilerek iki aşamalı olarak hazırlanmıştır. İlk aşamada öğrencilere sorulan soruların aynıysa öğretmenlere sorulmuştur. Fakat öğretmen ve öğretmen adaylarından soruları çözmeleri değil öğrencilerde olabilecek kavram yanlışlıklarını tahmin etmeleri istenmiştir. İkinci aşamada ise 5 tane öğrencinin ilk aşamadaki sorulara verdiği cevaplar bulunmaktadır. Bu aşamada öğretmen ve öğretmen adaylarından öğrenci cevaplarını incelemeleri ve kavram yanlışlıklarını belirlemeleri istenmiştir. Kavram yanlışlığı olduğunu düşündükleri cevaplar için ise sebeplerinin neler olabileceğini yazmaları istenmiştir. Bu testlerin yanı sıra öğretmen ve öğretmen adaylarına yarı yapılandırılmış mülakatlar uygulanmıştır.

4) Verilerin Analizi

Nitel çalışmalarda analiz hem veri toplama süreci hem de veri toplama süreci bittikten sonra yapılabilir. Bu tür çalışmalarda analiz yapılma nedeni şablonları, düşünceleri, açıklamaları ve anlamları keşfetmektir (Büyüköztürk, Çakmak, Akgün, Karadeniz ve Demirel, 2012). Araştırma için gerekli olan veriler, uygulanan kavram yanlışlığı testleri ve görüşmeler yoluyla elde edilmiştir. Bu veriler için, betimsel analiz yöntemi kullanılmıştır. Betimsel analizde görüşülen ya da gözlenen bireylerin görüşlerini çarpıcı bir şekilde yansıtmak amacıyla doğrudan alıntılara çok sık yer verilir. Bu betimlerden yola çıkarak araştırmacı kendi yorumlarını yapar ve bazı çıkarımlarda bulunur (Yıldırım & Şimşek, 2011).

BULGULAR VE YORUMLAR

1) Jale bir pizzanın $\frac{1}{2}$ 'sini yemiştir.

Ayşe de başka bir pizzanın $\frac{1}{2}$ 'sini yemiştir.

Jale, Ayşe'den daha fazla pizza yediğini söylüyor. Ayşe ise yediği pizzaların aynı olduğunu iddia ediyor. Kimin doğru dediği doğru olabilir? Açıklayınız.

Bu çalışma bir sorudan oluşmaktadır. Bu bölümde bu soru için verilen öğrenci cevaplar ve öğretmenlerin bu cevaplara yaptıkları yorumlar incelenecektir. Öncelikle bu sorunun çözümüne bakalım. Cevap 3 olası durumdan oluşmaktadır. Pizzaların büyüklüğü eşit ise Ayşe haklıdır. Pizzalar farklı ve Jale'nin pizzası büyük ise Jale haklıdır. Eğer Jale'nin pizzası küçük ise hiçbiri haklı değildir.

Öğrencilerin %80'i $\frac{1}{2}$ kesrindeki sayısal eşitlikten yola çıkarak Jale ve Ayşe'nin eşit yediğini söylemişlerdir.

Ayşe'nin dediği doğru. Çünkü $\frac{1}{2}$ ve $\frac{1}{2}$ aynı kesirlerdir.

Jale $\rightarrow \frac{1}{2}$
Ayşe $\rightarrow \frac{1}{2}$
Her ikisinde eşit miktarda yemektir.

Soruda geçen $\frac{1}{2}$ kesrinin sayısal eşitliğinden yola çıkarak Jale ve Ayşe'nin eşit miktarda yediğini sanan öğrencilerin kesir ifadesindeki sayısal değerlere odaklanarak bütünü göz ardı ettikleri söylenebilir. Fakat bu durum kesir konusundaki parça-bütün ilişkisinin oluşması için engel oluşturabilir. Çünkü kesirlerle temsil edilen miktar kesrin referans alındığı bütüne bağlıdır (Kouba, Zawojewski ve Strutchens, 1997; akt: Alacacı, 2010).

Öğretmen ve öğretmen adaylarının hepsi bu soru ile ilgili olarak öğrencilerin $\frac{1}{2}$ kesrinin sayısal eşitliğinden yola çıkarak "Jale ve Ayşe'nin eşit miktarda yediğini" söyleyeceği tahmininde bulunmuşlardır.

Öğrenci büyük bir pizzanın yarısıyla küçük bir pizzanın yarısının eşit olmayacağını bilmiyorsa ikisinde aynı miktarda pizza yediğini iddia edebilir. Yani öğrencinin kavram yanlılığı; miktarını önemsenmeden her şeyin yarısını aldığımızda eşit dur.

Öğretmen ve öğretmen adayları, öğrencilerin çoğunun bu soruda nasıl bir kavram yanlılığına düşeceğini kestirebilmelerine rağmen bu tip sorulara derste hiç yer vermediğini ifade etmişlerdir. Ali öğretmen, röportajlar esnasında "bu tip sorular öğretmen kılavuz kitaplarında olsaydı derste çözerdim" şeklinde açıklama yapmıştır. Kılavuz kitaplarında olmadığı için böyle bir şey üzerinde durmadığını da eklemiştir. Ayça öğretmen ise soruyu beğenmesine rağmen derste çözmek istemediğini söylemiştir. Çünkü bu tür soruların öğrencilerin kafasını karıştırabileceğini ifade etmiştir. Mehtap öğretmen ise soruda bir eksiklik olduğunu söylemiştir. Pizzaların büyüklüğünün farklı olduğunu söylemesinin yeterli olmadığını büyük, küçük veya eşit şeklinde ifade etmesi gerektiğini söylemiştir.

Öğrencilerin %8.8'i ise Jale ve Ayşe'nin yediği pizza büyüklüğünün "pizzanın dilim sayısına ya da pizzanın diliminin büyüklüğüne" göre değişeceğini söylemişlerdir.

İkisinde doğru olabilir. Çünkü büyüklük dilime bağlıdır.

e.s) Jale'nin dilimleri daha büyük olabilir. Ayşe'nin de küçük olabilir.

Yukarıdaki cevapları veren öğrenciler yenilen pizza miktarının pizza diliminin büyüklüğüne bağlı olacağını söylemişlerdir ki bu kavram yanlılığı bir cevaptır. Çünkü aynı boyutta bir pizzayı 8 dilime bölsük de veya 16

dilime bölsek de pizzanın büyüklüğü sabittir. Öğrencilerin böyle düşünmesine yol açan faktörlerden birisi birim kesir kavramı olabilir. Örneğin $\frac{1}{2}$, $\frac{1}{3}$, $\frac{1}{4}$ vb. kesirlerin büyüklüklerinin kıyaslanması istendiğinde bölünen parça sayısı azaldıkça bir dilimin büyüklüğü de artacaktır. Birim kesirlerde tek dilim veya parça üzerine çalışıldığından öğrenciler bir dilimi veya parçası büyük olan kesir büyüktür hatalı sonucuna varmış olabilirler. Bu durum öğrencilerin aşırı genelleme türünden bir kavram yanlışlığına dönüşmüş olabilir. Ya da öğretmenlerin ders anlatım şekli de öğrencilerin kavram yanlışlığına ortam hazırlayabilir. Çünkü öğretmen ve öğretmen adaylarından hiçbiri, öğrencilerin pizzanın büyüklüğüne dilim sayısından veya büyüklüğünden giderek bir yanlışlığa düşeceğini tahmin edememişlerdir. Öğrencilerin kavram yanlışlığı cevaplarına ise Mehtap öğretmen dışındaki herkes doğru demiştir.

Jale haklı olabilir. Çünkü Jale'nin yediği pasta Ayşe'ninkinden çok dilimli olabilir.

Yukarıdaki cevabı veren öğrencinin kavram yanlışlığına kaynaklık eden durum parça-bütün ilişkisinin tam olarak anlaşılammış olması olabilir.

Öğretmen ve öğretmen adaylarından hiçbiri, öğrencilerin pizza miktarının büyüklüğünü pizzanın dilim sayısına ya da pizzanın diliminin büyüklüğüne bağlayarak bir yanlışlığa düşebileceklerini tahmin edememişlerdir. Öğrencilerin kavram yanlışlığı içeren cevaplarına ise Mehtap öğretmen dışındaki tüm öğretmen ve öğretmen adayları doğru demişlerdir.

e.s.) Jale'nin dilimleri daha büyük olabilir. Ayşe'nin de küçük olabilir. Doğru

Öğretmen ve öğretmen adaylarına röportajda dilim büyüklüğünden yola çıkarak pizzanın büyüklüğünün tahmin edilip edilemeyeceği sorulduğunda ise hepsi pizzayı iki dilim düşündükleri için öğrenci cevaplarına doğru dediklerini ifade etmişlerdir. İki dilim olduğu kanısına nasıl vardıkları sorulduğunda ise yarım alınca genelde 2'ye bölündüğünü oradan bir genelleme yaptıklarını söylemişlerdir. Öğretmen adaylarından Buse röportaj esnasında “ $\frac{1}{2}$ deyince aklıma yarım geliyor. Yarım olarak düşündüğüm içinde 2'ye bölüyorum. Aslında öğrencilerin kavram yanlışlığı bizim verdiğimiz örneklerden kaynaklanıyor olabilir.” şeklinde bir açıklama yapmıştır. 10 yıllık tecrübeye sahip Ali öğretmen ise bu konuyu şöyle açıklamıştır (A.Ö: Ali öğretmen; A: Araştırmacı):

A: Öğrencinin pastanın büyüklüğüne dilim büyüklüğünden gitmesi doğru bir durum mudur?

A.Ö: Evet.

A: Peki, neden?

A.Ö: Çünkü pasta ikiye bölünüyor. Büyük olan pastanın dilimi daha büyük olacaktır.

A: İkiye bölündüğünü nasıl anladınız? Böyle bir bilgi verilmemiş.

A.Ö: Evet doğru söylüyorsunuz. Ben $\frac{1}{2}$ 'yi alırken zihnimde iki dilime böldüm. Doğru çok dilimlide olabilir. Öyleyse dilimden gidilmez. Kavram yanlışlığı bir cevap olur bu.

Röportaj sonunda cevaplarını değiştirerek dilim sayısından bütünü büyüklüğüne gidilmeyeceğini ifade ederek bu cevaba kavram yanlışlığı demişlerdir.

SONUÇ VE TARTIŞMA

Öğrencilerde kesirlerle temsil edilen miktarın referans alınan bütüne göre değişeceği (yani her şeyin $\frac{1}{2}$ 'sinin aynı miktara karşılık gelmediği) fikrinin yeterince kavranmadığı görülmüştür. Öğrenciler aynı sembollerle gösterilen kesirlerin aynı miktarı göstereceğini düşünmüşlerdir ve referans alınan bütünü hesaba katmamışlardır. Çalışmaya katılan öğretmen adayları, fiilen öğretmenlik yapmamış olmalarına rağmen öğrencilerin bu şekilde bir kavram yanlışlığına düşebileceklerini öngörebilmişlerdir. Öğretmenler de aynı şekilde öğrencilerin bu hataya düşebileceklerini ifade etmişlerdir. İlginç olan ise tecrübeli öğretmenlerin bu durumu öngörmesine rağmen kendilerine ait öğrencilerin bu kavram yanlışlığına düşmeleridir. Bu durum ileride yapılacak araştırmalara öncülük edebilir.

Bu kavram yanlışlığına düşmeyen ve pizzaların büyüklüğüne göre $\frac{1}{2}$ kesrinin sayısal değerlerinin değişeceğini ifade eden öğrencilerin neredeyse tamamı pizzanın büyüklüğünü ‘pizzadaki dilim sayısına’ (daha çok dilimli pizza daha büyük pizzadır) veya ‘dilimin büyüklüğüne’ (daha büyük dilimli pizza daha büyük pizzadır) bağlamışlardır. Bu öğrenciler referans alınan bütünü hesaba katmışlardır fakat bu bütünü büyüklüğüne karar

verirken yanılıya düşmüşlerdir. Diğer ilginç bir sonuç ise pizzaların dilim büyüklüğünü referans alarak pizzaların miktarının bulunabileceği kavram yanılısına düşen öğrencilerin cevaplarında öğretmen ve öğretmen adayları herhangi bir kavram yanılısı gör(e)memişler ve cevabı doğru kabul etmişlerdir. Ayrıca öğretmen ve öğretmen adayları röportajlar esnasında bu durumu fark etmiş ve fikirlerini değiştirerek öğrenci cevabının kavram yanılılı olduğu sonucuna varmışlardır. Buradan hareketle öğretmende ki kavram yanılılarının veya anlık hatalarının öğrencinin kavram yanılısına kaynaklık edebileceği sonucuna varılabilir. Ayrıca, Kouba ve arkadaşları (1997) çalışmasında bu konudaki kavram yanılısını, kesrin temsil ettiği miktarın, referans alınan bütün ile ilgili olduğu konusunda öğrencilerin yeterince deneyim yaşamamalarına bağlamıştır (Kouba, Zawojewski ve Strutchens, 1997; akt: Alacacı, 2010). İleride yapılacak çalışmalar öğretmenlerin kesirler konusunda öngörebildikleri kavram yanılılı hakkında önleyici aktiviteler yapıp yapmadıklarını ve sebeplerini incelemeli ve ne gibi aktivitelerle kavram yanılılılarını önlemeye çalıştıkları araştırılmalıdır.

KAYNAKLAR

- Alacacı, C., (2010). Öğrencilerin kesirler konusundaki kavram yanılılıları. E. Bingölbali ve M.F. Özmantar (Ed.), *Matematiksel Zorluklar ve Çözüm Önerileri*. Ankara: PegemA Yayıncılık.
- Büyüköztürk, Ş. Kılıç, Ç. E. Akgün, Ö. E. Karadeniz, Ş. & Demirel. F., (2012). *Bilimsel Araştırma Yöntemleri* (13. Baskı). Ankara: Pegem Akademi Yayınları.
- Eryılmaz, A. & Sürmeli, E., (2002). Üç Aşamalı Sorularla Öğrencilerin Isı ve Sıcaklık Konularındaki Kavram Yanılılılarının Ölçülmesi, *V. Ulusal Fen Bilimleri ve Matematik Eğitimi Kongresi*, 16-18 Eylül, ODTÜ, Ankara.
- Fennema, E. & Franke, M., (1992). *Teachers' knowledge and its impact in: D.A. Grouws (Ed) Handbook of Research on Mathematics Teaching and Learning* (New York: Macmillan Publishing).
- Küçük, A. & Demir, B., (2009). İlköğretim 6-8.Sınıflarda Matematik Öğretiminde Karşılaşılan Bazı Kavram Yanılılıları Üzerine Bir Çalışma. *Dicle Üniversitesi Ziya Gökalp Eğitim Fakültesi Dergisi*, 13, 97-112.
- Yenilmez, K. & Yaşa, E., (2008). İlköğretim Öğrencilerinin Geometrideki Kavram Yanılılıları. *Eskişehir Osmangazi Üniversitesi Eğitim Fakültesi Dergisi*, XXI(2), 461-483.
- Yıldırım, A. & Şimşek, H., (2011). *Sosyal Bilimlerde Nitel Araştırma Yöntemleri*. Ankara: Seçkin Kitapevi.
- Yılmaz, Z. & Yenilmez, K., (2007). İlköğretim 7. Ve 8. Sınıf Öğrencilerinin Ondalık Sayılar Konusundaki Kavram Yanılılıları. *Afyon Kocatepe Üniversitesi Fen Bilimleri Dergisi*, 8(1),269-290.

VERİ MADENCİLİĞİ İLE 7.SINIF ÖĞRENCİLERİNİN SAYILAR ÖĞRENME ALANINDAKİ PROBLEM ÇÖZME STRATEJİLERİNİN İNCELENMESİ

INVESTIGATION OF 7TH GRADE STUDENTS' PROBLEM SOLVING STRATEGIES IN NUMBERS LEARNING AREA BY USING DATA MINING

Yusuf Emre ERCİRE

yusuferc@gmail.com

(Milli Eğitim Bakanlığı) Manisa Kargın Ortaokulu

Serkan NARLI

serkan.narli@deu.edu.tr

Dokuz Eylül Üniversitesi Buca Eğitim Fakültesi İlköğretim Matematik Eğitimi ABD

Mustafa Zeki AYDOĞDU

mustafazeki20@hotmail.com

(Milli Eğitim Bakanlığı) İstanbul Söğütluçeşme Ortaokulu

Cenk KEŞAN

cenk.kesan@deu.edu.tr

Dokuz Eylül Üniversitesi Buca Eğitim Fakültesi İlköğretim Matematik Eğitimi ABD

ÖZET: Problem çözme bir düşünme yolu olup öğrenilenleri muhakeme etmede ve bütün matematik aktivitelerinde kullanılmaktadır. Bu yüzden de problem çözme stratejileri, birçok matematik eğitimi çalışmasında göze çarpmaktadır. Bu çalışmada farklı olarak öğrenme stratejileri arasındaki ilişkiler veri madenciliği ile araştırılmıştır. Veri madenciliği bir veri kümesinde kalıpların veya ilişkinin bulunması için çeşitli algoritmaların uygulaması olarak ifade edilebilmektedir. Çalışmada veriler, 2013-2014 eğitim öğretim yılının 2.döneminde Manisa Kargın Ortaokulu ve İstanbul Söğütluçeşme Ortaokulunda 7.sınıfta öğrenim gören 50 öğrenciden toplanmıştır. Öğrencilere açık uçlu sorulardan oluşan “sayılar öğrenme alanı 7. sınıf problem çözme stratejileri belirleme formu” dağıtılmıştır. Bu formlardan ve bu form doğrultusunda gereken tüm öğrenciler ile yapılan yarı yapılandırılmış görüşmelerden elde edilen veriler ile problem çözme stratejileri belirlenmiş ve bu stratejiler arasındaki ilişkiler veri madenciliği teknikleriyle irdelenmiştir.

Veri analizi devam etmekte olup, sonuçlar sempozyumda sunulacaktır.

Anahtar sözcükler: matematik, problem çözme, problem çözme stratejileri, veri madenciliği

ABSTRACT: Problem solving which is a way of thinking is used in reasoning and all mathematical activities. Therefore, problem solving strategies stand out in many mathematics education studies. In this study, unlike the others, the relationships between learning strategies were investigated with data mining. Data mining can be expressed as the application of different algorithms for determining the patterns or the relationship in a dataset. The data of the study was obtained from 50 students attending 7th grade at Manisa Kargın Secondary School and İstanbul Söğütluçeşme Secondary School in the 2nd term of 2013-2014 educational year. “The form of determining 7th grade problem-solving strategies in numbers learning area” consisting of open-ended questions were distributed to students. Problem solving strategies were determined with the data obtained from these forms and the semi-structured interviews conducted with all the students required in accordance with this form and the relationships between these strategies were examined with data mining techniques.

The data analysis is continuing and the results will be presented at the symposium.

Key words: mathematics, problem solving, problem solving strategies, data mining

ORTAÖĞRETİM ÖĞRENCİLERİNİN KUVVET VE HAREKET KONUSUNDAKİ KAVRAM İMAJLARI

FORCE AND MOTION CONCEPT IMAGES ON SECONDARY SCHOOL STUDENTS

Gülşah ALTUNTAŞ
Milli Eğitim Bakanlığı
gulsahaltnts@hotmail.com

Pervin ÜNLÜ YAVAŞ
Gazi Üniversitesi
pervinunlu@gazi.edu.tr

ÖZET: Çalışmanın amacı ortaöğretim öğrencilerinin kuvvet kavramına ve kuvvet ile hareket kavramları arasındaki ilişkiye ait kavram imajlarını belirlemektir. Araştırma amaçlı örneklem tekniğine göre belirlenmiş dokuzuncu sınıfa devam eden yedi öğrenci ile gerçekleştirilmiştir. Veriler yarı yapılandırılmış görüşmelerle elde edilmiştir. Görüşmelerde beşi kuvvet kavramı diğerleri ise kuvvet ile hareket arasındaki ilişkiye ait olmak üzere toplam dokuz soru sorulmuştur. Derinlemesine bilgi edinmek için görüşmeler sırasında ara sorular sorulmuştur. Ses kayıt cihazı kullanılarak kaydedilen konuşmalar metne dönüştürülmüştür. Metinler incelenerek kategoriler belirlenmiştir. Sonuç olarak kavram imajlarının bireyden bireye farklılık göstermesine rağmen öğrencilerin kuvveti genellikle temas kuvveti olarak algıladıkları ve cisimlerin hareket durumlarında yaptıkları değişiklikler ile açıklamaya çalıştıkları görülmüştür. Bu durumun ortaya çıkmasında öğrencilerin aldıkları eğitimin ve günlük hayat tecrübelerinin etkili olduğu düşünülmektedir. Araştırmada öğrencilerin kuvvet ve hareket kavramları ile ilgili kavram yanılgıları da belirlenmiştir.

Anahtar sözcükler: kavram imajı, kuvvet ve hareket, dokuzuncu sınıf öğrencileri.

ABSTRACT: This study aimed to find out the concept images of high school students about the concept of force and the relation between the concepts of force and motion. The participants of the study are seven students from ninth grade students were chosen through a purposeful sampling technique. Data were obtained using semi-structured interviews. During interviews, five questions on force concept and four questions on the relationship between the concept of force and motion were asked. Search for questions were asked during the interviews to obtain in-depth knowledge. The interviews recorded by audio recording device were converted into the text. Categories were created by examining these texts. Consequently, although this varies widely person to person images of the concept, the students often perceive the concept of force as contact force and were trying to explain the changes in the case of body motion. It is thought that the education students have acquired and daily life experiences they have gained play an important role over emerge of this result. According to research data about the concept of force and motion, misconceptions of the students are also identified.

Key words: concept image, force and motion, ninth grade students.

MATEMATİK ÖĞRETMEN ADAYLARININ MATEMATİKSEL KANIT YAPMAYA YÖNELİK GÖRÜŞLERİ

PROSPECTIVE MATHEMATICS TEACHERS' VIEWS ABOUT MATHEMATICAL PROOF

Cigdem ARSLAN
İstanbul University
arslanc@istanbul.edu.tr

Yasemin DERİNGOL KARATAS
İstanbul University
dyasemin@istanbul.edu.tr

ÖZET Matematik öğretiminin her kademesinde matematiksel kanıtın önemi bilinmekte olup tüm dünyada matematik öğretim programlarında ayrı bir yere sahiptir. Matematiksel kanıtı öğretecek olan öğretmen adaylarının bu konudaki görüşlerini öğrencilerine yansıtacakları gerçeği ve kanıtlamanın matematiksel düşünmenin gelişimindeki yeri göz önünde bulundurularak bu çalışmanın amacı öğretmen adaylarının matematiksel kanıt yapmaya yönelik görüşlerinin tespiti ve öğrenim gördükleri bölüme göre farklılık gösterip göstermediğini ortaya koymak olarak belirlenmiştir. Öğretmen adaylarının matematiksel kanıtla yönelik görüşlerini tespit etmek için İskenderoğlu, Baki ve Palancı (2011) tarafından geliştirilen “Matematiksel Kanıt Yapmaya Yönelik Görüş Ölçeği” kullanılmıştır. Ölçek 27 maddeli 5’li likert tarzıdır. Bu bağlamda araştırmanın çalışma grubunu Eğitim Fakültesi İlköğretim Matematik Öğretmenliği Bölümü öğrencileri ile Fen Fakültesi mezunu olup öğretmenlik sertifikası almak üzere Eğitim Enstitüsüne devam eden lise matematik öğretmen adayları oluşturmuştur.

Anahtar sözcükler: matematiksel kanıt, matematik öğretmen adayı, ispata yönelik görüş

ABSTRACT: Mathematical proof has an important and distinct place at all levels of mathematics curriculum in mathematics teaching all over the world and considered crucial to the development of mathematical thinking. Prospective mathematics teachers' views on mathematical proof who will teach on this subject is of importance ,because thier views will reflect to students. The purpose of this study was to investigate and compare prospective secondary and elementary school mathematics teachers' views on proving. “Questionnaire for Constructing Mathematical Proof ” developed by İskenderoğlu, Baki and Palancı (2011) administrated to teacher candidates to determine their views about proof. The scale is 5-point Likert-Type and consists of 27 items. In this context, the study group of the research consisted of prospective elementary school mathematics teachers enrolled to Faculty of Education and prospective secondary mathematics teachers enrolled to pedagogical education program of Institute of Education Sciences.

Key words: mathematical proof, prospective mathematics teachers, views on mathematical proof

PRESERVICE SCIENCE TEACHERS' PERCEPTIONS OF GENETICALLY MODIFIED ORGANISMS: A METAPHOR ANALYSIS

Isil KOC

Meltem KUVAC

The purpose of this research was to determine preservice science teachers' perceptions of "genetically modified organisms" through the use of metaphors. The research was conducted with 54 preservice science teachers from Istanbul University in the Fall term of 2013-2014 academic year. The qualitative research method with phenomenology pattern was utilized in this research. For the data collection, a form that included the phrase "Genetically modified organisms(GMOs) are like; because" was given to participants and required to complete to articulate their conceptualizations of GMOs. Data were analyzed with the content analysis technique. According to results, participants produced 31 distinct and valid mental images grouped into six distinct conceptual categories that characterize GMOs. Based on findings, most frequent metaphors utilized by participants were obese people, imitation, and mystery box. Overall, the results indicate that metaphors can be utilized as a strong research tool to reveal the preservice science teachers' perceptions on the concept of GMOs.

Keywords: Genetically modified organisms, metaphor, metaphor analysis, teacher education

INTERACTIVE E-LEARNING MATERIALS PRODUCTION AND SAMPLE APPLICATIONS IN THE FIELD OF MATHEMATICS

Celal Murat KANDEMİR

Today, thanks to rapid developments in the information and communication technologies (ICT), learning styles of the students have been getting more and more changes. There is a few time less than 20 minutes in order to attract attention of the new learners named as digital generation, and to keep their motivations at the same levels. Thus, the course materials are offered to the students through being prepared in small pieces instead of in one batch. After giving fundamental information intended to teach, preparing interactive e-learning materials, which enable students to learn by themselves in order to reinforce the learning, can be carried out easily by using today's information and communication technologies. To provide more benefits from information and communication technologies in education, the Act of Increasing Opportunities and Improving Technology called briefly "FATİH project" was introduced with the 52 pilot schools in 2011. Under the scope of the project, e-learning content is required in order to be used inside and outside of the classroom by the teachers and the students. These contents play an important role in the use of information and communication technologies in education, and the success of FATİH project. Using of Information and communication technologies to support learning by teachers, preparing e-learning materials by the teachers themselves, and being able to update existing materials, when it is required are important. In this study, a road map is proposed for the teachers in order to develop interactive e-learning materials, which can attract new learners' attentions, and sample applications are developed for the different subjects in the field of elementary mathematics through using this proposed road map. When developing interactive e-learning materials, some information about the selection of free or open source software and about how to use them are given in there.

Keywords: e-öğrenme, etkileşimli içerik, bit okur yazarlığı, eğitim teknolojileri

SINIF ÖĞRETMENLERİNİN MATEMATİK KAYGISI

Ramazan GÜRBÜZ,

Kenan YILDIRIM

Bu çalışmanın amacı, sınıf öğretmenlerinin matematik kaygı düzeylerini çeşitli değişkenler açısından incelemektir. Araştırma, bir ilde bulunan farklı ilkokullarda görev yapan ve rastgele seçilen 559 sınıf öğretmenin katılımıyla gerçekleştirilmiştir. Veri toplama aracı olarak, Üldaş (2005) tarafından geliştirilen Öğretmen ve Öğretmen Adaylarına Yönelik Matematik Kaygı Ölçeği (MKÖ-Ö) kullanılmıştır. Verilerin analizinde, "t" testi ve varyans analizi (ANOVA) kullanılmıştır. Yapılan analizler sonucunda, sınıf öğretmenliği mezunu öğretmenlerin matematik kaygı puanlarının, diğer anabilim dallarından mezun öğretmenlerin kaygı puanlarından daha düşük olduğu tespit edilmiştir. Öte yandan, sınıf mevcudu arttıkça öğretmenlerin matematik kaygılarının da arttığı belirlenmiştir. Bunların yanı sıra, 4. sınıf öğretmenlerinin matematik kaygılarının diğer sınıfları okutan öğretmenlerden daha fazla olduğu ve mesleğiyle ilgili yayınları takip eden öğretmenlerin matematik kaygılarının takip etmeyenlerden daha düşük olduğu saptanmıştır.

The aim of this study is to primary school teachers' math anxiety level in terms of examine of several variables. The study was carried out with 559 classroom teachers working in different primary schools in a province of Turkey. As data collection tool, Mathematics Anxiety Scale for Teachers and Teacher Candidates (MKÖ-Ö) developed by Üldaş (2005) was used. In order for analyzing the data, "t" test and analysis of variance (ANOVA) was used. According to the research results, When analyzed teachers' mathematics anxiety scores, As a result of the analysis, mathematics anxiety scores of primary school teaching graduates were lower than the scores of teachers from other departments. In addition, teachers' mathematics anxiety increased with increasing class size. Also, math anxiety of fourth-grade teachers was more than teachers of other grades. However, math anxiety of teachers who follow publications related his/her job were lower than those not follow.

Anahtar Kelimeler: sınıf öğretmeni, kaygı düzeyi, matematik kaygısı

oooooooooooooooo

SINIF ÖĞRETMENLERİNİN MATEMATİK KAYGISI

Ramazan GÜRBÜZ

Kenan YILDIRIM

Bu çalışmanın amacı, sınıf öğretmenlerinin matematik kaygı düzeylerini çeşitli değişkenler açısından incelemektir. Araştırma, bir ilde bulunan farklı ilkokullarda görev yapan ve rastgele seçilen 559 sınıf öğretmenin katılımıyla gerçekleştirilmiştir. Veri toplama aracı olarak, Üldaş (2005) tarafından geliştirilen Öğretmen ve Öğretmen Adaylarına Yönelik Matematik Kaygı Ölçeği (MKÖ-Ö) kullanılmıştır. Verilerin analizinde, "t" testi ve varyans analizi (ANOVA) kullanılmıştır. Yapılan analizler sonucunda, sınıf öğretmenliği mezunu öğretmenlerin matematik kaygı puanlarının, diğer anabilim dallarından mezun öğretmenlerin kaygı puanlarından daha düşük olduğu tespit edilmiştir. Öte yandan, sınıf mevcudu arttıkça öğretmenlerin matematik kaygılarının da arttığı belirlenmiştir. Bunların yanı sıra, 4. sınıf öğretmenlerinin matematik kaygılarının diğer sınıfları okutan öğretmenlerden daha fazla olduğu ve mesleğiyle ilgili yayınları takip eden öğretmenlerin matematik kaygılarının takip etmeyenlerden daha düşük olduğu saptanmıştır.

The aim of this study is to primary school teachers' math anxiety level in terms of examine of several variables. The study was carried out with 559 classroom teachers working in different primary schools in a province of Turkey. As data collection tool, Mathematics Anxiety Scale for Teachers and Teacher Candidates (MKÖ-Ö) developed by Üldaş (2005) was used. In order for analyzing the data, "t" test and analysis of variance (ANOVA) was used. According to the research results, When analyzed teachers' mathematics anxiety scores, As a result of the analysis, mathematics anxiety scores of primary school teaching graduates were lower than the scores of teachers from other departments. In addition, teachers' mathematics anxiety increased with increasing class size. Also, math anxiety of fourth-grade teachers was more than teachers of other grades. However, math anxiety of teachers who follow publications related his/her job were lower than those not follow.

Keywords: classroom teachers, level of anxiety, mathematics anxiety

PRESERVICE SCIENCE TEACHERS' PERCEPTIONS OF GENETICALLY MODIFIED ORGANISMS: A METAPHOR ANALYSIS

Isil KOC

Meltem KUVAC

The purpose of this research was to determine preservice science teachers' perceptions of "genetically modified organisms" through the use of metaphors. The research was conducted with 54 preservice science teachers from Istanbul University in the Fall term of 2013-2014 academic year. The qualitative research method with phenomenology pattern was utilized in this research. For the data collection, a form that included the phrase "Genetically modified organisms(GMOs) are like; because" was given to participants and required to complete to articulate their conceptualizations of GMOs. Data were analyzed with the content analysis technique. According to results, participants produced 31 distinct and valid mental images grouped into six distinct conceptual categories that characterize GMOs. Based on findings, most frequent metaphors utilized by participants were obese people, imitation, and mystery box. Overall, the results indicate that metaphors can be utilized as a strong research tool to reveal the preservice science teachers' perceptions on the concept of GMOs.

Keywords: Genetically modified organisms, metaphor, metaphor analysis, teacher education

İKİ AŞAMALI ÇOKTAN SEÇMELİ TEST KULLANILARAK ÖĞRENCİLERİN “MADDENİN TANECİKLİ YAPISI” ÜNİTESİ İLE İLGİLİ ALTERNATİF KAVRAMALARININ BELİRLENMESİ

DETERMINATION of STUDENTS’ ALTERNATIVE CONCEPTIONS on THE PARTICULATE NATURE OF MATTER SUBJECT BY USING TWO-TIER MULTIPLE CHOICE TEST

Dr. Osman KENAN
Trabzon Bener Cordan Ortaokulu
osman_kenan@hotmail.com

Prof. Dr. Haluk ÖZMEN
KTÜ Fatih Eğitim Fakültesi İlköğretim Bölümü
hozmen61@hotmail.com

ÖZET: Bu çalışmanın amacı, öğrencilerin Maddenin Tanecikli Yapısı (MTY) ünitesinde yer alan kavramlarla ilgili sahip oldukları alternatif kavramların iki aşamalı çoktan seçmeli sorular içeren kavram testi kullanılarak belirlenmesidir. Çalışmada, araştırmacılar tarafından geliştirilen ve iki aşamalı çoktan seçmeli sorulardan oluşan “Maddenin Tanecikli Yapısı Kavram Testi (MTYKT)” Trabzon ilindeki bir ortaokulda, 6. sınıfta, iki farklı şubede öğrenim gören toplam 82 öğrenciye uygulanmıştır. Çalışma sonucunda öğrencilerin “Maddenin Tanecikli Yapısı” ünitesi ile ilgili birçok alternatif kavramaya sahip oldukları görülmüştür. Ayrıca iki aşamalı testlerin, öğrencilerin alternatif kavramalarının nedenleriyle birlikte ortaya çıkarılmasında etkili şekilde kullanılabileceği görülmüştür.

Anahtar sözcükler: Maddenin Tanecikli Yapısı, İki Aşamalı Çoktan Seçmeli Test, Alternatif Kavrama

ABSTRACT: The aim of this study it to determine students’ alternative conceptions related to the particulate nature of matter subject by using a concept test which includes two-tier multiple choice questions. “The Particulate Nature of Matter Concept Test (PNMCT)”, which was developed by the researchers and included two-tier multiple choice questions, was applied 82 grade 6 students in Trabzon. The results of study show that students have several alternative questions related to the particulate nature of matter concept subject. And also, it was seen that two-tier multiple choice questions could be effectively used for determining students’ alternative conceptions with their possible reasons.

Key words: The Particulate Nature of Matter, Two-Tier Multiple Choice Test, Alternative Conceptions

GİRİŞ

Öğrencilerin, öğrenme ortamına gelmeden önce çeşitli deneyimleri sonucu sahip oldukları hatalı düşüncelere “kavram yanılgısı (misconceptions)”, “alternatif kavrama (alternative conceptions)”, ön kavrama (preconceptions) gibi birçok farklı isim verilmektedir (Özmen, 2004). Bu çalışmada hatalı öğrenci inançlarını ifade etmek üzere alternatif kavrama ifadesinin kullanılması tercih edilmiştir. Alternatif kavramalar, bilimsel olarak kabul görmese de, çocuğun bakış açısına göre mantıklı olduklarından zihinlerine iyice yerleşmiş durumdadırlar (Gilbert, Osborne & Fensham, 1982). Bu nedenle sonraki öğrenmelerini ve zihinlerinde yeni ve doğru kavramları geliştirmelerini olumsuz yönde etkilemektedir.

Literatürde alternatif kavramaların belirlenmesinde çok çeşitli araçlar kullanılmaktadır. Bu amaçla açık uçlu ve çoktan seçmeli sorular ile mülakatlar daha sık kullanılmakla birlikte, kısa cevaplı soruların, çizimlerin, doküman analizinin, kavram haritalarının ve TGA yönteminin de kullanıldığı görülmektedir. Bu veri toplama araçlarından biri veya birkaçı birlikte kullanılarak öğrencilerin MTY ve ilişkili kavramlarla ilgili anlamalarının ve alternatif kavramaların belirlendiği çalışmalara literatürde rastlanmaktadır.

Çoktan seçmeli testler, amacına uygun olarak hazırlandığında, öğrencilerin sahip oldukları alternatif kavramları belirlemede önemli bir veri toplama aracı olarak kullanılabilir. Ancak çoktan seçmeli testlerle öğrencilerin taşıdıkları alternatif kavramalar hakkında bilgi sahibi olunabilirken verilen cevapların nedenleriyle ilgili bilgi sahibi olunamaz (Ayas, 1995). Bu nedenle çoktan seçmeli testlerin olumlu yönlerini taşıyıp olumsuz yönlerini en aza indiren iki aşamalı teşhis edici testler geliştirilmiş ve fen bilimleri eğitiminde yaygın bir biçimde

kullanılmıştır (Tan, Goh, Chia & Treagust, 2002; Voska & Heikkinen, 2000). Bu tip testler öğrencilerin sahip oldukları kavramaların ve bu kavramaların nedenlerinin ortaya çıkarılmasında kolaylık sağlamaktadır (Tan, Taber, Goh & Chia, 2005). Temelde iki bölümden oluşan bu tür testlerde, birinci bölüm öğrencilerin durum hakkında tahminde buldukları, ikinci bölüm ise birinci kısımda verilen cevabın nedeninin araştırıldığı bölümdür (Tan ve diğ., 2005). İkinci kısım çoktan seçmeli seçeneklerden oluşabileceği gibi açık uçlu seçeneklerden de oluşabilir. Eğer ikinci kısım çoktan seçmeli ise kullanılan çeldiricilerde öğrencilerin doğru olduğunu düşündükleri yanlış ve ilginç bilgilere yer verilmesi önerilmektedir (Treagust, 1988).

Bu çalışmada hem fen bilimlerinin hem de kimyanın en temel konularından birisi olan maddenin tanecikli yapısı ile ilgili olarak geliştirilen iki aşamalı çoktan seçmeli sorulardan oluşan test ile öğrencilerin kavramsal anlamalarının ve alternatif kavramalarının belirlenmesi amaçlanmıştır. Literatürde maddenin tanecikli yapısı konusunda çok sayıda araştırma olsa da (Çakmak, 2009; Kenan, 2005; Yeziarski, 2003), iki aşamalı çoktan seçmeli sorular içeren veri toplama araçlarına çok sık rastlanmamaktadır. Bu nedenle çalışmada öğrencilerin alternatif kavramalarının belirlenmesinde, verilen cevapların nedeninin de belirtilmesini gerektiren iki aşamalı çoktan seçmeli sorulardan oluşan bir test kullanılmıştır.

YÖNTEM

Bu çalışmada, 6. sınıf öğrencilerinin “Maddenin Tanecikli Yapısı” ünitesi ile ilgili alternatif kavramalarının belirlenmesinde, araştırmacılar tarafından geliştirilen, seçeneklerde cevabın nedeninin yer aldığı iki aşamalı çoktan seçmeli (two-tier multiple choice) sorulardan oluşan bir test (MTYKT) kullanılmıştır. MTYKT'nin geliştirilmesinde, Treagust (1988) tarafından önerilen metodolojiye göre Treagust ve Chandrasegaran (2007) tarafından ortaya konulan model kullanılmıştır. Bu model, geliştirilen içeriğin belirlenmesi, öğrencilerin alternatif kavramaları hakkında bilgi edinilmesi ve iki aşamalı teşhis testinin geliştirilmesi basamaklarından ve bu basamaklara ait alt basamaklardan oluşmaktadır.

Test, başlangıçta birinci aşaması farklı sayıda seçenek içeren çoktan seçmeli, ikinci aşaması ise öğrencilerdeki yaygın alternatif kavramaların belirlenip seçeneklere yerleştirilmesi amacıyla açık uçlu 18 soru olarak hazırlanmıştır. Uzman görüşleri dikkate alınarak birinci aşaması doğru-yanlış türü sorulara dönüştürülmüş ve soru sayısı 20'ye çıkarılmıştır. Böylece bütün soruların aynı formatta olması sağlanmıştır. Test bu haliyle ön uygulamanın yapıldığı 38 kişilik öğrenci grubuna ön test olarak uygulanmıştır. Öğrencilerden, soruların birinci aşamasında verilen yargının doğru ya da yanlış olduğunu belirtmeleri, ikinci aşamada ise düşüncelerinin sebebini yazmaları istenmiştir. Bu uygulama sonucu elde edilen cevaplar listelenerek frekanslanmıştır. Elde edilen yüksek frekansa sahip alternatif kavramalar testin ikinci aşamasının çoktan seçmeli olarak düzenlenmesinde kullanılmıştır.

Birinci kısmı doğru-yanlış ikinci kısmı dört seçenekten oluşan çoktan seçmeli 20 sorudan oluşan testin ilk hali araştırmacılar tarafından literatürden de faydalanılarak geliştirilmiştir (Kenan, 2005). Testin çoktan seçmeli ikinci aşamasında kullanılan alternatif kavrama içeren çeldiriciler, ilgili literatürden ve soruların ikinci aşamasının açık uçlu sorulardan oluşan halinin uygulanmasıyla elde edilen öğrenci cevaplarından yararlanılarak oluşturulmuştur. Bazı sorularda (19. ve 20. sorular) tanecik düzeyinde gösterimlere yer verilmiştir. Bazı soru kökleri ve seçenekleri literatürde kullanılan (Çakmak, 2009; Kenan, 2005; Yeziarski, 2003) MTY ile ilgili öğrenci anlamalarının belirlenmesi amacıyla hazırlanan testlerden yararlanılarak hazırlanmıştır. 1, 4, 9, 10, 11, 12. sorular Çakmak (2009) tarafından geliştirilen testten, 20. soru ise Yeziarski (2003) tarafından geliştirilen testten alınarak yeniden düzenlenmiştir. MTYKT'nin geçerliliğinin sağlanmasında uzman ve öğretmen görüşlerine başvurulmuştur. Bu amaçla test kimya eğitimi alanında uzman üç öğretim üyesi ve dört fen bilimleri öğretmenin incelemesine sunulmuştur. Uzman görüşleri doğrultusunda gerekli değişiklik ve düzenlemeler yapılmıştır.

Yapılan düzeltmelerin ardından test, toplam 80 (40+40) öğrenciden oluşan bir gruba pilot olarak uygulanmıştır. Testin Cronbach alfa güvenilirlik katsayısı 0,887 olarak hesaplanmıştır. Geliştirme süreci tamamlanan test, Trabzon ilindeki bir ortaokulda, 6. sınıfta, iki farklı şubede öğrenim gören toplam 82 (41+41) öğrenciye “Maddenin Tanecikli Yapısı” ünitesiyle ilgili alternatif kavramalarının belirlenmesi amacıyla, ünitenin öğretiminden önce uygulanmıştır.

MTYKT'deki maddelerde doğru cevap seçeneğinin yanı sıra, alternatif kavramaları içeren seçenekler (çeldiriciler) de yer almaktadır. Çeldiricilerden herhangi birini işaretleyen öğrencinin, o çeldiricide ifade edilen alternatif kavramalara sahip olduğu (Kenan, 2005; Treagust, 1988) kabul edilmiştir. Bu nedenle, her iki aşamada teste verilen cevaplar analiz edilirken, her bir test maddesindeki tüm cevap seçeneklerinin öğrenciler tarafından doğru cevap olarak işaretlenme yüzdeleri hesaplanmıştır.

BULGULAR

Öğrencilerinin alternatif kavramalarına yönelik hazırlanan iki aşamalı çoktan seçmeli bir test olan MTYKT'den elde edilen öğrencilerin cevap yüzdeleri Tablo 1'de verilmiştir.

Tablo 1. MTYKT'ye Verilen Cevaplara Ait Yüzde Dağılımları

Soru	I. AŞAMA A	II. AŞAMA (GEREKÇE)				Toplam (%)	Soru	I. AŞAMA A	II. AŞAMA (GEREKÇE)				Toplam (%)
		A (%)	B (%)	C (%)	D (%)				A (%)	B (%)	C (%)	D (%)	
1	Doğru	18,3	51,2*	9,8	3,7	82,9	11	Doğru	2,4	3,7	4,9	3,7	14,7
	Yanlış	0	0	1,2	15,9	17,1		Yanlış	14,6	56,1*	2,4	12,2	85,3
	Toplam	18,3	51,2	11	19,6	100		Toplam	17	59,8	7,3	15,9	100
2	Doğru	28	4,9	2,4	15,9*	51,2	12	Doğru	32,9	14,6	6,1	1,2	54,8
	Yanlış	14,6	4,9	17,1	12,2	48,8		Yanlış	3,7	4,9	7,3	28*	43,9
	Toplam	42,6	9,8	19,5	28,1	100		Toplam	36,6	19,5	13,4	29,2	98,7
3	Doğru	19,5	26,8	12,2	13,4	71,9	13	Doğru	18,3*	8,5	6,1	6,1	39
	Yanlış	3,7	8,5	8,5*	6,1	26,8		Yanlış	4,9	37,8	7,3	11	61
	Toplam	23,2	35,3	20,7	19,5	98,7		Toplam	23,2	46,3	13,4	17,1	100
4	Doğru	7,3	31,7	3,7	14,6	57,3	14	Doğru	11	28	13,4	13,4	65,8
	Yanlış	31,7*	1,2	4,9	3,7	41,5		Yanlış	14,6*	8,5	4,9	4,9	32,9
	Toplam	39	32,9	8,6	18,3	98,8		Toplam	25,6	36,5	18,3	18,3	98,7
5	Doğru	12,2	52,4	9,8	8,5	82,9	15	Doğru	13,4	6,1	23,2	17,1	59,8
	Yanlış	3,7	4,9	2,4	6,1*	17,1		Yanlış	12,2*	3,7	8,6	12,2	36,7
	Toplam	15,9	57,3	12,2	14,6	100		Toplam	25,6	9,8	31,8	29,3	96,5
6	Doğru	0	32,9	31,7	13,4	78	16	Doğru	40,2	25,6	12,2	7,3	85,3
	Yanlış	0	6,1	12,2*	2,4	20,7		Yanlış	1,2	2,4	4,9*	2,4	10,9
	Toplam	0	39	43,9	15,8	98,7		Toplam	41,4	28	17,1	9,7	96,2
7	Doğru	11	11	17,1	23,2*	62,3	17	Doğru	29,3	2,4	35,4	8,5	75,6
	Yanlış	13,4	7,3	4,9	9,8	35,4		Yanlış	3,7	4,9	4,9	8,5*	22

	Toplam	24,4	18,3	22	33	97,7		Toplam	33	7,3	40,3	17	97,6
	Dođru	48,9	32,9	4,9	6,1	92,8		Dođru	20,7	3,7	34,1	13,4	71,9
8	Yanlıř	1,2	2,4	2,4*	1,2	7,2	18	Yanlıř	2,4	9,8*	9,8	3,7	25,7
	Toplam	50,1	35,3	7,3	7,3	100		Toplam	23,1	13,5	43,9	17,1	97,6
	Dođru	56,1	2,4	7,3	4,9	70,7		Dođru	15,9	6,1	17,1	3,7	42,8
9	Yanlıř	1,2	13,4*	8,5	4,9	28	19	Yanlıř	3,7*	22	24,4	6,1	56,2
	Toplam	57,3	15,8	15,8	9,8	98,7		Toplam	19,6	28,1	41,5	9,8	99
	Dođru	34,1	6,1	6,1	3,7	50		A	2,4	1,2	1,2	17,1	22
	Yanlıř	4,9	19,5	19,5*	3,7	47,6		B	7,3	15,9*	4,9	2,4	30,5
10	Toplam	39	25,6	25,6	7,4	97,6	20	C	2,4	1,2	0,0	0,0	3,7
								D	36,6	4,9	1,2	1,2	43,9
								Toplam	48,8	23,2	7,3	20,7	100

*:Her iki ařamayı da dođru cevaplayan ođrenci yzdzeleri

Tablo 1’de gdrldüđü gibi MTYKT’nin birinci sorusunda, ođrencilerin %17,1’i bütün maddelerin tanecikli yapıda olmadığı alternatif kavramasına sahipken, biri hariç, bu ođrenciler bu durumun maddeden maddeye deđiřeieceđine inanmaktadır. Testin ikinci sorusunda, ođrencilerin % 42,6’sı katı ve sıvıların bütünsel yapıda, gazların ise tanecikli ve boşluklu yapıda olduđu alternatif kavramasına sahiptir. Ođrencilerin 19,5’i ise sadece sıvı ve gaz tanecikleri arasında boşluk olduđu alternatif kavramasına sahiptir.

Üçüncü soruda ođrencilerin %71,9’u sıkıştırılan hava taneciklerinin řeklinin deđiřeieceđi alternatif kavramasına sahiptir. Sıkıştırmanın etkisiyle ođrencilerin %19,5’i hava taneciklerinin ezileieceđi, %23,2’si hava taneciklerinin küçüleieceđi, %35,3’ü ise hava taneciklerinin birbirine yapışacağı alternatif kavramasına sahiptir. Dördüncü soruda, ođrencilerin %57,3’ü demir bir tel makasla ortadan ikiye bölündüđünde bölünen yerdeki atomların da ikiye bölüneieceđi alternatif kavramasına sahiptir. Bu alternatif kavramaya sahip ođrencilerin %31,7’si gerekçe olarak maddenin her türlü bölünmesinde atomların da bölüneieceđini belirtmiştir.

Testin beřinci sorusunda, ođrencilerin %82,9’u genleşmenin tanecik büyüklüđünde meydana gelen deđiřimden kaynaklandığına inanmaktadır. Ođrencilerin %57,3’ü ise ısınma etkisiyle taneciklerin genleşieceđi alternatif kavramasına sahiptir. %15,9’u ısı etkisi ile taneciklerin birbiri ile birleşip büyüyeieceđi, %12,2’si ise taneciklerin parçalanıp sayılarının artacağı alternatif kavramasına sahiptir. Altıncı soruda ođrencilerin %78’i tuzun su içerisinde yok olacağı alternatif kavramasına sahip iken, gerekçe olarak ođrencilerin %39’u katı maddenin taneciklerinin eriyieceđini ifade etmiştir

Yedinci soruda ođrencilerin %18,3’ü bir sıvının taneciklerinin diđerinin taneciklerini ezerek küçüleieceđi, %22’si taneciklerin birbirini sıkıştırmasından dolayı tanecikler arası boşlukların azalacağı alternatif kavramasına sahiptir. Testin sekizinci sorusunda, sorunun birinci ařamasında ođrencilerin %92,8’i boya taneciklerinin su taneciklerini yeřile boyayacağı alternatif kavramasına sahipken, ikinci ařamada gerekçe olarak ođrencilerin %50,1’i yeřil renkli boya taneciklerinin renksiz su taneciklerine çarparak onları da yeřile boyayacağı alternatif kavramasına sahiptir. Ođrencilerin %35,3’ü ise yeřil renkli boya taneciklerinin su tanecikleriyle birleşerek onları da yeřil yapacağı alternatif kavramasına sahiptir.

Dokuzuncu soruda ođrencilerin %70,7’si atomların ışık mikroskopuyla görülebileieceđine inanırken, gerekçe olarak ođrencilerin %57,3’ü mikroskopların, atom gibi küçük nesnelere gözle görülebilir hale getirebileieceđine inanmaktadır. Onuncu soruda ođrencilerin yarısı altın atomlarının sarı renkli olduđu alternatif kavramasına sahip iken, gerekçe olarak ođrencilerin %39’u atomların fiziksel özelliklerinin maddelerle aynı olmasını

göstermektedir. Sorunun birinci aşamasında öğrencilerin %47,6'sı altın atomlarının sarı renkli olmayacağını belirtirken bu öğrencilerin %19,5'i gerekçe olarak ayrılan atomun rengini kaybedeceğini belirtmiştir.

On birinci sorunun birinci aşamasını doğru cevaplayan öğrencilerin oranı %85,3 iken, farklı elementlerin atomlarının birbirinden farklı özellikte olduğu gerekçesiyle demir telin atomları ile bakır telin atomlarının farklı olduğunu belirterek sorunun her iki aşamasını doğru cevaplayan öğrencilerin oranı %56,1'dir. On ikinci soruda, öğrencilerin %54,8'i ezilen teneke kutudaki atomların da ezileceği alternatif kavramasına sahiptir. Gerekçe olarak öğrencilerin %36,6'sı atomların şeklinin değişeceği, %19,5'i hacimlerinin küçüleceği ve %13,4'ü ise ezilerek farklı atomlara dönüşeceği alternatif kavramalarını belirtmiştir.

On üçüncü soruda öğrencilerin %61'i su ve karbondioksitin yapısındaki oksijen atomlarının farklı olduğu alternatif kavramasına sahiptir. Buna gerekçe olarak ise öğrencilerin %46,3'ü su ve karbondioksitin farklı bileşikler olmasını göstermiştir. On dördüncü soruda, öğrencilerin %65,8'i su moleküllerinin birbirinden farklı olabileceği alternatif kavramasına sahiptir. Gerekçe olarak öğrencilerin %36,5'i bütün su moleküllerindeki hidrojen ve oksijen atomlarının dizilişinin farklı olabileceği, %18,3'ü her bir su molekülünün farklı sayıda oksijen ve hidrojen atomlarından oluşabileceği ya da maddenin haline göre molekülleri arasında farklılık olabileceği alternatif kavramalarına sahiptir. On beşinci soruda öğrencilerin %59,8'i bileşiklerin saf madde olmadığına inanmaktadır. Bu alternatif kavramaya sahip öğrencilerin %23,2'si gerekçe olarak bileşiklerin farklı cins atomlardan oluşmasını, %17,1'i ise bileşiklerin farklı elementlerden meydana gelmesini göstermiştir.

On altıncı soruda öğrencilerin %85,3'ü sıvılar donduğunda taneciklerinin de donacağı alternatif kavramasına sahiptir. Bu öğrencilerin %40,2'si sıvıların donduğunda taneciklerinin de donacağı, %25,6'sı ise donan sıvının taneciklerinin birbirine yapışacağı ve aralarında boşluk kalmayacağı alternatif kavramalarını gerekçe olarak göstermiştir. On yedinci soruda öğrencilerin %75,6'sı atomların da öleceği alternatif kavramasına sahiptir. Bu alternatif kavramaya sahip öğrencilerin %29,3'ü gerekçe olarak atomların hareket etmesini, %35,4'ü ise canlıların da atomlardan meydana gelmesini göstermiştir.

On sekizinci soruda, öğrencilerin %71,9'u buharlaşma esnasında su moleküllerinin ağırlığının azalacağı alternatif kavramasına sahiptir. Bu alternatif kavramaya sahip öğrencilerin %34,1'i gaz halde maddelerin moleküllerinin en hafif olacağı alternatif kavramasını gerekçe göstermektedir. On dokuzuncu soruda verilen tanecik modelinin saf bir maddeye ait olmadığını belirten öğrencilerin (%56,2) gerekçe olarak %22'si modelde farklı cins atomların olmasını, %24,4'ü ise farklı iki elementin birleşmesinden oluşmasını göstermiştir.

Testin yirminci sorusunda, su buharlaştığında su molekülünü oluşturan atomların büyüdüğünü gösteren tanecik modelini seçen öğrencilerin oranı %22 iken, öğrencilerden %17,1'i bu seçeneğin gerekçesi olarak ısınan su moleküllerinin genişleşerek büyüyeceğini belirtmiştir. Öğrencilerin %43,9'u ise molekülü oluşturan atomların birbirinden ayrıldığını gösteren modeli tercih etmiştir. Bu modeli tercih ederek atomların birbirinden ayrılacağı gerekçesini seçen öğrencilerin oranı ise %36,6'dır.

SONUÇLAR

Elde edilen bulgular öğrencilerin, maddelerin tanecikli ve boşluklu yapıda olduğu fikri, tanecik kavramı, taneciklerin şekli, boyutu, ağırlığı, kütlesi, rengi, canlılığı, hareketi, sayısı, aralarındaki boşluklar gibi fiziksel özellikleri ve bu özelliklerde meydana gelen değişimlerle ilgili olarak çeşitli alternatif kavramalara sahip olduklarını göstermektedir. Öğrenciler maddelerin ısıtılması, soğutulması, hal değiştirilmesi, sıkıştırılması, ezilmesi ve basınca maruz kalması gibi durumlarda taneciklerin özelliklerinde değişme olacağına dair alternatif kavramalar taşımaktadır. Ayrıca, öğrencilerin genellikle maddelerin makroskobik özelliklerini ve bu özelliklerdeki değişimleri taneciklere de uygulama eğiliminde olduklarını göstermektedir. Diğer bir deyişle öğrenciler, maddelerde meydana gelen sıkışma, genişleme, büzülme, hal değişimleri gibi fiziksel değişimlerin taneciklerindeki aynı şekildeki değişimlerden kaynaklandığına inanmaktadır. Literatürde öğrencilerin maddenin makroskobik özellikleriyle, taneciklerin özelliklerinin aynı olduğuna inanma eğiliminde olduklarını ortaya koyan çalışmalar yer almaktadır (Boz, 2006). Ayrıca öğrenciler atom, molekül, element, bileşik gibi kavramlarla ilgili olarak mikroskobik düzeyde çeşitli alternatif kavramalar göstermektedir.

Belirlenen alternatif kavramaların yanı sıra, elde edilen bulgulardan, öğrencilerin iki aşamalı sorulara alışkın olmadıkları, düşüncelerini gerekçelendirilmede yetersiz kaldıkları, iki aşamalı soruların her iki aşamasını da doğru cevaplayan öğrencilerin oranlarının oldukça düşük olmasından anlaşılmaktadır.

Sonuç olarak öğrencilerin, maddenin tanecikli yapısı, taneciklerin özellikleri ve meydana gelen değişimler ile tanecik, atom, molekül, element, bileşik ve saf madde kavramları ile ilgili olarak birçok alternatif kavramaya sahip oldukları söylenebilir. Bu alternatif kavramaların belirlenmesinde ve özellikle düşüncelerin gerekçelerinin ortaya çıkarılmasında iki aşamalı testler etkili bir şekilde kullanılabilir. Böylece öğretim öncesinde öğrencilerin ön bilgileri ve alternatif kavramaları ortaya çıkarılarak, gerekçeleri bilinen alternatif kavramalarla etkili bir şekilde mücadele edilebilir ve alternatif kavramaların giderilmesine yönelik uygun öğretim ortamları düzenlenebilir.

KAYNAKLAR

- Ayas, A. (1995). *Lise I kimya öğrencilerinin maddenin tanecikli yapısı kavramını anlama seviyelerine ilişkin bir çalışma*. II. Ulusal Fen Bilimleri Eğitimi Sempozyumu, ODTÜ Eğitim Fakültesi, Ankara.
- Boz, Y. (2006). Turkish pupils' conception of the particulate nature of matter. *Journal of Science Education and Technology*, 15, 203-213.
- Çakmak, G. (2009). *Altıncı sınıfta yer alan bazı temel kimya kavramlarının öğretimine yönelik hazırlanan yapılandırmacı temelli materyallerin etkililiğinin araştırılması*. Yayınlanmamış yüksek lisans tezi, KTÜ, Trabzon.
- Gilbert, J. K., Osborne, R. & Fensham, P. J. (1982). Children's science and its consequences for teaching, *Science Education*, 66(4), 623-633.
- Kenan, O. (2005). İlköğretim farklı seviyelerindeki öğrencilerin maddenin tanecikli yapısı kavramını anlama seviyelerinin ve yanlış anlamalarının belirlenmesi. *Yayınlanmamış yüksek lisans tezi*, KTÜ, Trabzon.
- Özmen, H. (2004). Some students' misconceptions in chemistry: A literature review of chemical bonding. *Journal of Science Education and Technology*, 13(2), 147-159.
- Tan, K. C. D., Goh, K. N., Chia, S. L. & Treagust, D. F. (2002). Development and application of a two-tier multiple choice diagnostic instrument to assess high school students' understanding of inorganic chemistry qualitative analysis. *Journal of Research in Science Teaching*, 39(4), 283-301.
- Tan, K. C. D., Taber, K. S., Goh, N. K. & Chia, L. S. (2005). The ionization energy diagnostic instrument: A two-tier multiple-choice instrument to determine high school students' understanding of ionization energy. *Chemistry Education Research and Practice*, 6(4), 180-197.
- Treagust, D. F. (1988). Development and use of diagnostic tests to evaluate students' misconception in science, *International Journal of Science Education*, 10(2), 159-169.
- Treagust, D. F. & Chandrasegaran, A. L. (2007). The Taiwan national science concept learning study in an international perspective. *International Journal of Science Education*, 29(4), 391-403.
- Voska, K. W. & Heikkinen, H. W. (2000). Identification and analysis of student conception used to solve chemical equilibrium problems. *Journal of Research in Science Teaching*, 37(2), 160-176.
- Yeziarski, E. J. (2003). The particulate nature of matter and conceptual change: A cross-age study. *Doctoral dissertation*, Arizona State University.

MADDENİN TANECİKLİ YAPISI İLE İLGİLİ ANLAMALARIN BELİRLENMESİNDE TAHMİN-GÖZLEM-AÇIKLAMA YÖNTEMİNİN VE ÇALIŞMA YAPRAKLARININ KULLANIMI

USING PREDICTION-OBSERVATION-EXPLANATION METHOD and WORKSHEETS to DETERMINE CONCEPTIONS on the PARTICULATE NATURE OF MATTER

Dr. Osman KENAN
Trabzon Bener Cordan Ortaokulu
osman_kenan@hotmail.com

Prof. Dr. Haluk ÖZMEN
KTÜ Fatih Eğitim Fakültesi İlköğretim Bölümü
hozmen61@hotmail.com

ÖZET: Bu çalışmanın amacı, öğrencilerin Maddenin Tanecikli Yapısı (MTY) ile ilgili anlamalarının belirlenmesinde Tahmin-Gözlem-Açıklama (TGA) yönteminin ve çalışma yapraklarının etkililiğini araştırmaktır. Çalışma, Trabzon ilindeki bir ortaokulun bir 6. sınıfında öğrenim gören toplam 38 öğrenci üzerinde yürütülmüştür. Veriler TGA yöntemine göre hazırlanmış ve çalışma yapraklarıyla desteklenmiş bilgisayar destekli öğretim (BDÖ) uygulamaları esnasında, öğrencilerin çalışma yapraklarına yazdıkları tahmin, gözlem ve açıklamalarından elde edilmiştir. Çalışma sonucunda, çalışma yapraklarıyla desteklenen TGA yönteminin öğrencilerin alternatif kavramalarının detaylı olarak belirlenmesinde etkili bir şekilde kullanılabileceği görülmüştür.

Anahtar sözcükler: Maddenin Tanecikli Yapısı, TGA Yöntemi, Çalışma Yapağı, Alternatif Kavrama.

ABSTRACT: The aim of the study is to investigate the effectiveness of Prediction-Observation-Explanation (POE) method and worksheets in determining the students' conceptions on the Particulate Nature of Matter (PNM). The sample of the study consisted of 38 grade 6 students in Trabzon. The data were collected from the prediction-observation and explanations written on the worksheets during the computer assisted instruction (CAI) application which was designed according to POE and enriched with worksheets. It was seen that POE enriched with worksheets could be effectively used for determining students' alternative conceptions in detail.

Key words: The Particulate Nature of Matter, POE Method, Worksheet, Alternative Conception

GİRİŞ

Alternatif kavramaların giderilebilmesi için öncelikle konu ile ilgili alternatif kavramalar mümkün olduğunca eksiksiz belirlenmelidir. Literatüre bakıldığında alternatif kavramaların belirlenmesinde çok çeşitli araçlar kullanılmaktadır. Bu araçlardan açık uçlu ve çoktan seçmeli sorular ile mülakatlar daha sık kullanılmakla birlikte, kısa cevaplı soruların, çizimlerin, doküman analizinin, kavram haritalarının ve TGA yönteminin de kullanıldığı görülmektedir. Bu veri toplama araçlarından biri veya birkaçı birlikte kullanılarak öğrencilerin diğer kavramlarda olduğu gibi MTY ve ilişkili kavramlarla ilgili anlamalarının ve sahip oldukları alternatif kavramaların belirlendiği literatürde görülmektedir.

Literatürde yapılan çalışmalar incelendiğinde öğrencilerin anlama düzeylerini ve alternatif kavramalarını belirlemede çoğunlukla çeldiricileri kavramla ilgili değişik alternatif kavramaları içeren çoktan seçmeli testlerin kullanıldığı görülmektedir. Fakat çoktan seçmeli testlerle öğrencilerin taşıdıkları kavram yanılgıları hakkında bilgi sahibi olunabilirken verilen cevapların nedenleriyle ilgili bilgi sahibi olunamaz. Bu nedenle yazılı cevap gerektiren testler daha detaylı bilgi edinme imkânı sağladıkları için tercih edilirler. Yazılı cevap gerektiren testler özellikle kavramların anlaşılma düzeyini tespit etmede yaygın olarak kullanılırlar (Ayas, 1995). Ayrıca çizimler öğrencilerin kavramları zihinlerinde nasıl canlandırdıklarını ortaya koyar. Zira çizimler kavramların zihinsel yapılaşmasını ortaya çıkaran en önemli soru çeşitlerinden birisidir (Ayas ve Özmen, 2002). Çizimler, öğrencilerin zihinlerinde gizli kalmış bilgi ve inanışları ve öğrenme kalitesini kelimelerle sınırlandırmadan ortaya çıkardığı için tercih edilirler. Aynı zamanda çizimler öğrencilerin mikroskobik seviyede öğrenmelerini de

ortaya çıkarır. Tanecikler düzeyindeki çizimler, anlama düzeyleri ile ilgili çalışmalarda yaygın olarak kullanılmaktadır (Kokkotas, Vlachos ve Koulaidis 1998; Singer, Tal ve Wu, 2003; Tsai, 1999).

Literatürde TGA yöntemi, MTY konusu da dahil olmak üzere, çeşitli konularla ilgili öğrencilerin alternatif kavramalarının belirlenmesinde etkili bir şekilde kullanılmaktadır (Liu ve Lesniak, 2006; Stern, Barnea ve Shauli, 2008). Çalışma yaprakları da öğretim etkinliklerinin belirlenen aşamalarda, belirli bir bütünlük içerisinde sırayla sunulmasına imkan sağladığı için diğer yöntem ve tekniklerle birlikte sıklıkla tercih edilmektedir (Şahin ve Çepni, 2012; Türk ve Çalık, 2008). Böylece öğrencilerin ilgilerinin çekilip dikkatlerinin toplanması, ön bilgilerinin belirlenmesi, içeriğin adım adım takip edilmesi, görüş ve düşüncelerinin alınması ve değerlendirme yapılmasına imkân sağlanmaktadır. Bu çalışmada, TGA yönteminin adımları takip edilerek öğrencilerin MTY ile ilgili konulardaki düşüncelerinin alınması amacıyla çalışma yapraklarının ve TGA'nın birlikte kullanılması amaçlanmıştır. Bu bağlamda çalışmanın amacı, öğrencilerin MTY ile ilgili anlamalarının belirlenmesinde TGA yönteminin ve çalışma yapraklarının etkililiğinin birlikte araştırılmasıdır.

YÖNTEM

Bu çalışma Trabzon il merkezinde bir ortaokulun 6. sınıfında öğrenin gören 38 öğrenci üzerinde yürütülmüştür. Çalışmada, 6. sınıf öğrencilerinin MTY ile ilgili anlamalarının ve alternatif kavramalarının belirlenmesinde TGA yöntemine göre hazırlanan çalışma yaprağı kullanılmıştır. Uygulama iki ders saatinde yapılmıştır. TGA yöntemine göre düzenlenen etkinlik çalışma yaprağı kullanılarak yürütülmüştür. Demir, su ve hava bulunan şırıngaların sıkıştırılmasının yer aldığı etkinlikte, öğrencilerden tahmin, gözlem ve açıklamalarını çalışma yapraklarında yer alan sorulara ait boşluklara yazmaları istenmiştir. Öğrenciler cevaplarını bireysel olarak dersin işlenişi sırasında ilgili boşluklara yazmış ve sınıf içi tartışmalar yürütülmüştür. İçerikte makroskobik ve tanecikler düzeyinde tahmin, gözlem ve açıklamalara yer verilmiştir. Açıklama basamağında kavramsal değişim metinleri kullanılmış ve metinlerin girişinde literatürde yer alan alternatif kavramalarla ilgili sorulara yer verilmiştir. Çalışmada kullanılan çalışma yaprağından bir bölüm Şekil 1'de verilmiştir.

Adı ve Soyadı:
Sınıfı:
No:

2. Etkinlik
ŞIRINGA

*Tanecik nedir?
Maddenin tanecikleri
dendiğinde ne anlıyorsunuz?
Bütün maddeler
taneciklerden mi oluşur?*

BDÖ materyalinde 1. Bölümdeki 2. Etkinliği açınız. Yönergeleri takip ederek soruları cevaplayınız.

1. İçerisinde demir, su ve hava bulunan şırıngaları sıkıştırmaya çalışırsan ne olur? Tahminini gerekçesiyle beraber yazar mısın?

.....

 *İleri butonuyla geçiniz ve şırıngaları pistonlarına tıklayarak sıkıştırmaya çalışın. Gözleminizi yaptıktan sonra ileri butonuyla geçin ve ilgili videoyu izleyin.*

2. Ne gözlemledin? Gözlemini yazar mısın?

.....



 *İleri butonuyla geçiniz ve sıradaki soruyu cevaplayınız.*

3. Gözlemlediğin bu durumu nasıl açıklarsın? Açıklamanı gerekçesiyle beraber yazar mısın?

.....

 *İleri butonuyla geçiniz ve sıradaki çizimi yapınız.*

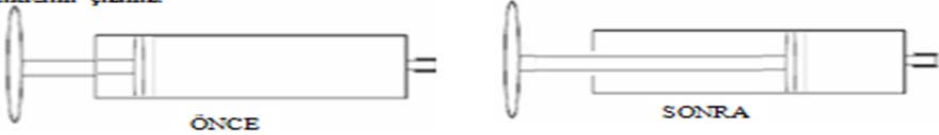
4. Piston sıkıştırılmadan önce ve sıkıştırıldıktan sonra hava taneciklerinin ilk ve son hali nasıl olur? Taneciklerini çiziniz.

Şekil 1. Şırınga Etkinliği Çalışma Yaprağından Bir Bölüm.

Çalışma yapraklarından elde edilen verilerin analizinde “Anlama”, “Kısmen Anlama”, “Alternatif Kavrama” ve “Anlamama” olmak üzere dört kategori kullanılmıştır. Literatürde anlama düzeylerine ilişkin yapılan çalışmalarda açık uçlu soruların analizinde bu ve benzeri kategoriler değişik araştırmacılar tarafından kullanılmıştır (Abraham, Williamson ve Westbrook, 1994; Ayas ve Özmen, 2002; Kenan, 2005; Kokkotas ve diğ., 1998). Testin bu bölümünde verilen öğrenci cevaplarının analizi yukarıda belirtilen kategorilere uygun olarak yapılmış ve öğrenci cevaplarının yüzdeleri sunulmuştur. Çizimle ilgili olan dördüncü sorunun analizinde

literatürde de yer alan “Sürekli”, “Tanecikli” ve “Tanecikli Çok Hatalı” kategorileri kullanılmıştır (Ayas ve Özmen, 2002; Kenan, 2014; Özmen, Ayas ve Coştu, 2002).

BULGULAR

TGA'ya göre düzenlenen çalışma yapraklarının birincisinde hava, su ve demirin sıkıştırılmasına yer verilen “Şırınga” etkinliği yer almaktadır. Yapılan etkinlikle ilgili olarak öğrenciler çalışma yaprağında yer alan soruları yazılı olarak cevaplamıştır. TGA'nın tahmin aşamasında yer alan “İçerisinde demir, su ve hava bulunan şırıngaları sıkıştırmaya çalışırsan ne olur? Tahminini gerekçesiyle beraber yazar mısın?” sorusuna öğrencilerin %55,3'ü sadece havanın sıkıştırılabileceğini, su ve demirin sıkıştırılmayacağını doğru olarak belirtmiştir. Bu cevabı veren öğrencilerin %47,6'sı gerekçe belirtmezken, %19'u gazların sıkıştırılabileceğini fakat katı ve sıvıların sıkıştırılmayacağını belirtmiştir. Yalnızca üç öğrenci gaz tanecikleri arasındaki boşlukların daha fazla olduğunu belirterek doğru gerekçe belirtmiştir. Örneğin bir öğrenci “Çünkü havayı oluşturan taneciklerin arasındaki boşluk, diğer maddelerin tanecikleri arasındaki boşluktan çok daha fazladır.” cevabını vermiştir. Üç öğrenci ise diğer maddelerden farklı olarak havanın tanecikleri arasında boşluk olduğu şeklinde alternatif kavrama içeren gerekçe belirtmiştir. Bir öğrenci gerekçe olarak ise “Demir ve suyun arasında boşluk azdır, ama havanın moleküllerinin arasında hava vardır.” şeklinde alternatif kavrama içeren açıklama yapmıştır. Öğrencilerin %26,3'ü ise su ve havanın sıkıştırılabileceğini, demirin ise sıkıştırılmayacağını belirtmiştir. Bu öğrencilerden üç tanesi (%7,9) demir taneciklerinin sıkışık, birleşik ya da yapışık olduğunu belirterek demirin sıkıştırılmayacağını belirtmiştir. Öğrencilerden biri, katı olduğu için, bir öğrenci de sert olduğu için demirin sıkışmayacağını belirtmiştir. Bir öğrenci sıkıştırılınca suyun taşacağını, havanın ise boşalacağını belirtirken, bir öğrenci su ve hava tanecikleri arasında demire göre daha fazla boşluk bulunduğunu belirtmiştir. Üç öğrenci ise gerekçe belirtmemiştir. Öğrencilerin %10,5'i hiçbirinin sıkıştırılmayacağını belirtirmiştir. Bu öğrenciler gerekçe belirtmemiştir. Birer öğrenci ise sadece demirin katı olduğu için sıkışacağını belirtmiştir. Bir öğrenci de gerekçe belirtmeden demir ve suyun sıkışacağını belirtmiştir.

TGA'nın gözlem aşamasında çalışma yaprağında yer alan “Ne gözlemledin? Gözlemini yazar mısın?” sorusuna bir öğrenci tahmininde olduğu gibi su ve demirin sıkıştığını, havanın ise sıkışmadığını belirtmiştir. Diğer bütün öğrenciler ise yaptıkları gözlem sonucunda havanın sıkıştırılabildiğini, su ve demirin sıkıştırılmadığını belirtmiştir. Bu öğrencilerden sıkıştırılan havanın eski haline döndüğünü belirten bir öğrenci bu duruma su ve demirde az tanecik bulunmasını gerekçe göstermiştir. Benzer şekilde başka bir öğrenci ise “Gazın tanecikleri demirin ve suyunun göre daha fazladır” şeklinde alternatif kavrama içeren açıklamada bulunmuştur.

TGA'nın açıklama aşamasında çalışma yaprağında yer alan “Gözlemlediğin bu durumu nasıl açıklarsın? Açıklamanı gerekçesiyle beraber yazar mısın?” sorusuna iki öğrenci haricindeki tüm öğrenciler tanecikli yapı fikrini kullanarak açıklamalarda bulunmuştur. Öğrencilerin %68,4'ü “Anlama” kategorisine dahil edilen açıklamalarda bulunmuştur. Öğrencilerin %50'si tanecikler arası boşluklarla, %18,4'ü ise taneciklerin temas halinde olup olmaması ile olayı açıklamıştır. Bir öğrencinin “Su ve demirin tanecikleri bitişik olduğu için sıkışmadı, ama havanın molekülleri ayrı olduğu için sıkıştı.” cevabı örnek olarak verilebilir. Öğrencilerin %23,7'si alternatif kavrama içeren açıklamalarda bulunmuştur. Bazı öğrenciler (%13,2) demir ve suyun arasında boşluk ya da hava boşluğu olmadığı, havanın arasında ise hava boşluğu olduğuna dair alternatif kavramalara sahiptir. Bazı öğrenciler (%7,9) ise hava ya da gaz taneciklerinin daha az olmasını gerekçe göstermiştir. Bir öğrencinin sadece gazların sıkıştırılabileceğini belirten açıklaması “Kısmen Anlama”, iki öğrencinin boş cevapları “Anlamama” kategorisine dahil edilmiştir.

TGA'nın tanecik düzeyinde tahmin aşamasında çalışma yaprağında yer alan “Piston sıkıştırılmadan önce ve sıkıştırıldıktan sonra hava taneciklerinin ilk ve son hali nasıl olur? Taneciklerini çiziniz.” sorusunda yapılan çizimlerde yalnızca iki öğrenci kabul edilebilir “Tanecikli” kategorisine dahil edilen gösterimlerde bulunmuştur. Öğrencilerin %89,5'i “Tanecikli Hatalı” kategorisine dahil edilen çizimler yapmıştır. Öğrencilerin %68,4'ü bu çizimlerinde sıkıştırma sonucu taneciklerin sayısının arttığını gösteren çizimler yapmıştır (Şekil 2). Dört öğrenci ise sıkıştırma sonucu tanecik sayısını daha az gösterimlerde bulunmuştur. Öğrencilerin %15,8'i sıkıştırma sonucu taneciklerin küçüldüğünü gösteren çizimler yapmıştır (Şekil 3). İki öğrenci ise sıkıştırılan hava taneciklerini daha büyük göstermiştir. Sıkıştırılmadan önce tanecikleri düzenli dizilmiş olarak gösteren çizim yapan öğrenci bulunmazken, öğrencilerin %57,9'u sıkıştırıldıktan sonra, katıların tanecikli gösterimine yakın düzenli dizilimde gösterimler yapmıştır (Şekil 2). Öğrencilerin %52,6'sı ise sıkıştırıldıktan sonra bütün tanecikleri birbiri ile temas halinde göstermiştir (Şekil 2). Üç öğrenci ise sıkıştırılan hava için bütünsel yapıyı çağrıştıran gösterimlerde bulunmuştur.

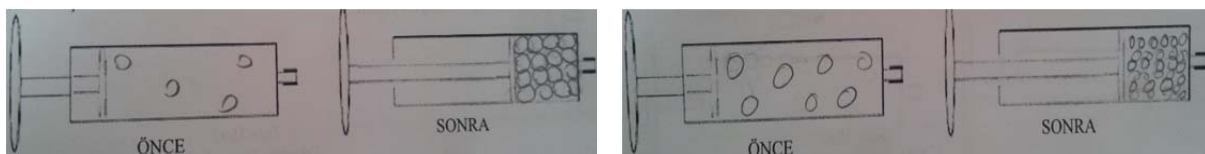

Şekil 2, 3. Alternatif Kavrama İçeren Öğrenci Çizimleri

Maddelerin tanecikli yapılarını BDÖ materyali üzerinde inceledikten sonra çalışma yaprağındaki “Bu maddelerin tanecikli yapılarını göz önünde bulundurarak bu durumu nasıl açıklarsın?” sorusuna öğrencilerin %68,4’ü tanecikli yapı fikrini kullanarak “Anlama” kategorisine dahil edilen cevaplar vermiştir. Bir öğrencinin “*Katı tanecikleri sıkışık ve düzenli, sıvı tanecikleri sıkışık ve düzensiz, hava tanecikleri sıkışık değil ve düzensiz.*” cevabı örnek olarak verilebilir. Öğrencilerin %47,4’ü tanecikler arası boşluklardan, %13,2’si taneciklerin diziliminden ve %7,9’u ise taneciklerin hareketinden bahsederek benzer açıklamalar yapmıştır. Öğrencilerin %21,1’i ise bu aşamada alternatif kavrama içeren cevaplar vermiştir. Alternatif kavramaya sahip öğrencilerin büyük çoğunluğu katı ve sıvı tanecikleri arasında boşluk olmadığı alternatif kavramasına sahiptir. Bir öğrenci “*Hava, yani gazda hava boşlukları çoktur*” ifadesini kullanmıştır. İki öğrenci ise demir ve su taneciklerinin hareketsiz olduğunu belirtmiştir. Bu öğrencilerden biri “*Su ve demir tanecikleri boşluk kalmayacak şekilde yerleştiği için hareket edemezler*” ifadelerine yer vermiştir. Dört öğrenci ise yetersiz ya da makroskobik düzeyde açıklamada bulunarak “Kısmen Anlama” kategorisinde cevap vermiştir.

Çalışma yaprağında yer alan ve TGA’nın açıklama basamağında kullanılan kavramsal değişim metni öncesinde sorulan “Bütün maddelerin tanecikleri arasında boşluk var mıdır? Neden?” sorusuna öğrencilerin %47,4’ü doğru gerekçe belirterek “Anlama” kategorisinde cevap vermiştir. Bu öğrenciler taneciklerin hareket edebilmesi için boşlukların gerekli olduğunu, boşluk olmasaydı katı taneciklerinin titreşim hareketi yapamayacaklarını belirten açıklamalarda bulunmuştur. Öğrencilerin %34,2’si “Kısmen Anlama” kategorisinde cevaplar vermiştir. Bu kategoriye tanecikler arasında boşluklar bulunduğunu gerekçesiz olarak belirten öğrenci cevapları dahil edilmiştir. Bazı öğrenciler katı tanecikleri arasındaki boşlukların yok denecek kadar az olduğunu, sıvı tanecikleri arasındaki boşlukların daha fazla ve gaz tanecikleri arasındaki boşlukların ise en fazla olduğunu belirtmiştir. Öğrencilerin %18,4’ü bu soruya “Alternatif Kavrama” kategorisine dahil edilen cevaplar vermiştir. Bütün maddelerin tanecikleri arasında boşluk bulunmadığına bazı öğrenciler katı ve sıvıların sıkıştırılmayışını gerekçe göstermiştir. Bazı öğrenciler ise sadece gaz tanecikleri arasında boşluklar bulunduğu alternatif kavramasına sahiptir.

Çalışma yaprağında yer alan ve TGA’nın açıklama basamağında kullanılan diğer bir kavramsal değişim metni öncesinde yer alan “Maddeler sıkıştırıldığında taneciklerinde ne gibi değişiklikler olur? Taneciklerin şeklinde, büyüklüğünde, sayısında bir değişim olur mu?” sorusuna öğrencilerin %50’si maddeler sıkıştırıldığında taneciklerin şeklinde, büyüklüğünde, sayısında bir değişim olmayacağını sadece tanecikler arası boşlukların değişeceğini belirterek “Anlama” kategorisine giren cevaplar vermiştir. Öğrencilerin %18,4’ü herhangi bir değişiklik olmayacağını, havanın hacminin küçüleceğini belirterek “Kısmen Anlama” kategorisine giren cevaplar vermiştir. Öğrencilerin %28,9’u ise değişim olacağını belirterek alternatif kavrama içeren cevaplar vermiştir. Öğrencilerin taneciklerin hacminin küçüleceği, taneciklerin büyüklüğünde, şeklinde, sayısında, değişim olacağı, taneciklerin ezileceği, hareketlerinin azalacağı, boşlukların artacağına dair alternatif kavramalara sahip oldukları görülmüştür. Bir öğrenci ise “Anlamama” kategorisinde cevap vermiştir.

Çalışma yaprağının son sorusunda öğrencilere “Maddeler sürekli bir yapıya mı sahiptir, yoksa taneciklerden mi meydana gelmiştir?” şeklinde bir soru yöneltilmiştir. Bu soruya öğrencilerin %73,7’si maddelerin taneciklerden meydana geldiğini belirterek “Anlama” kategorisinde cevaplar vermiştir. Geriye kalan öğrencilerin çoğunluğu soruyu boş bırakmıştır. Bir öğrenci ise “Sürekli aynı yapıdadır.” şeklinde cevaplamıştır.

SONUÇLAR

TGA yönteminin tahmin aşamasında öğrencilerin ön bilgileri gerekçeleriyle birlikte, gözlem aşamasında olaylar hakkındaki makroskobik düzeydeki açıklamaları, açıklama aşamasında ise makroskobik düzeyde meydana gelen değişimleri tanecik düzeyinde meydana gelen değişimlerle açıklama düzeyleri incelenmiştir. Elde edilen bulgular öğrencilerin makroskobik düzeyde meydana gelen değişimleri tanecikli yapı fikrini kullanarak açıklamada yetersiz olduklarını ve maddelerin makroskobik özelliklerini ve bu özelliklerdeki değişimleri taneciklere de uygulama eğiliminde olduklarını göstermektedir. Diğer bir deyişle öğrenciler, maddelerde meydana gelen sıkışma gibi fiziksel değişimlerin taneciklerindeki aynı şekildeki değişimlerden kaynaklandığına inanmaktadır. Bu durum öğrencilerin çeşitli alternatif kavramalar geliştirmelerine neden olmaktadır (Kenan, 2005). Zira literatürde öğrencilerin maddenin makroskobik özellikleriyle, taneciklerin özelliklerinin aynı olduğuna inanma eğiliminde olduklarını ortaya koyan çalışmalar yer almaktadır (Boz, 2006; Kokkotas ve diğ., 1998). Ayrıca makroskobik olaylar ile moleküler düzeydeki etkileşimler arasında öğrencilerin doğru ilişkileri kuramadıkları bilinmektedir (Tsai, 1999).

Elde edilen bulgular, öğrencilerin katı, sıvı ve gaz haldeki maddelerin tanecikli yapısı, tanecikler arası boşluklar ve maddelerin sıkıştırılması esnasında bu boşluklarda meydana gelen değişimlerle ilgili olarak anlama güçlüğü çektiklerini ve alternatif kavramalara sahip olduklarını ortaya koymaktadır. Bazı öğrenciler sıvıların sıkıştırılabileceğine ve sıkıştırılma sonucu tanecikleri arasındaki uzaklığın değişeceğine dair yanılgılara sahiptir. Bazı öğrenciler ise sadece sıvı ve gaz tanecikleri arasında boşluk olduğu alternatif kavramasına sahiptir. Öğrencilerin maddenin üç hali için tanecikler arası uzaklıklar hakkında sorun yaşadıkları sonucu Periera ve Pestana (1991) tarafından yapılan çalışmada da ortaya konmuştur. Öğrencilerin, maddelerin tanecikleri (Kenan, 2005) özellikle katı tanecikleri arasında (Griffiths ve Preston, 1992; Kenan, 2005) boşluk olmadığı yönünde alternatif kavramalara sahip oldukları literatürde de ifade edilmektedir. Literatürde öğrencilerin, sıvı tanecikleri arasındaki boşlukların katılarla gazlar arasında olduğuna dair alternatif kavramalara sahip oldukları belirtilmektedir (Adadan, 2006). Ayrıca öğrenciler taneciklerin şeklinde ve büyüklüğünde değişme olacağına dair alternatif kavramalara sahiptir. Testin üçüncü sorusunda öğrenciler, sıkıştırılan hava taneciklerinin şeklinin değişeceği, ezileceği ve küçüleceği alternatif kavramalarına sahiptir. Gazların sıkıştırılabildiğini bilen öğrenciler bu sıkışmayı taneciklerin küçülmesi ile açıklamaya çalışmaktadır. Literatürde de öğrencilerin “Maddeler sıkıştırıldığında tanecikleri küçülür” alternatif kavramasına sahip olduğu belirtilmektedir (Özmen ve Kenan, 2007).

Uygulama süresince çalışma yaprakları kullanılarak, öğrencilerin bütün cevap ve açıklamalarını çalışma yaprağına yazmaları sonucu bütün öğrencilerin katılımının ve düşüncelerinin alınması sağlanmıştır. Bunun sonucunda derse katılmaya istekli olmayan ve çeken öğrenciler bile düşüncelerini rahatlıkla yazılı olarak ifade edebilmiştir.

Sonuç olarak; öğrencilerin, anlama düzeylerinin ve alternatif kavramalarının belirlenmesinde ve özellikle düşüncelerin detaylı bir şekilde ve gerekçeleriyle ortaya çıkarılmasında TGA yöntemi ve çalışma yapraklarının etkili bir şekilde kullanılabileceği anlaşılmıştır. Böylece ön bilgileri ve alternatif kavramaları ortaya çıkarılarak öğrencilerin alternatif kavramalarının farkına varmaları ve alternatif kavramalarıyla daha etkili bir şekilde mücadele etmeleri sağlanabilir.

KAYNAKLAR

- Abraham, M. R., Williamson, V. M. and Westbrook, S. L. (1994). A cross-age study of the understanding of five chemistry concepts. *Journal of Research in Science Teaching*, 31(2), 147-165.
- Adadan, E. (2006). Promoting high school students' conceptual understandings of the particulate nature of matter through multiple representations. Doctoral dissertation, The Ohio State University, USA.
- Ayas, A. (1995). *Lise I kimya öğrencilerinin maddenin tanecikli yapısı kavramını anlama seviyelerine ilişkin bir çalışma*. II. Ulusal Fen Bilimleri Eğitimi Sempozyumu, ODTÜ Eğitim Fakültesi, Ankara.
- Ayas, A. ve Özmen, H. (2002). Lise öğrencilerinin maddenin tanecikli yapısı kavramını anlama seviyelerine ilişkin bir çalışma. *Boğaziçi Üniversitesi Eğitim Fakültesi Dergisi*, 19(2), 45-60.
- Boz, Y. (2006). Turkish pupils' conception of the particulate nature of matter. *Journal of Science Education and Technology*, 15, 203-213.
- Griffiths, A.K. and Preston, K. R. (1992). Grade-12 students' misconceptions relating to fundamental characteristics of atoms and molecules. *Journal of Research in Science Teaching*, 29(6), 611-628.
- Kenan, O. (2005). İlköğretim farklı seviyelerindeki öğrencilerin maddenin tanecikli yapısı kavramını anlama seviyelerinin ve yanlış anlamalarının belirlenmesi. *Yayınlanmamış yüksek lisans tezi*, KTÜ, Trabzon.
- Kenan, O. (2014). “Maddenin tanecikli yapısı” ünitesine yönelik zenginleştirilmiş bilgisayar destekli öğretim materyalinin geliştirilmesi ve etkililiğinin araştırılması. *Yayınlanmamış doktora tezi*, KTÜ, Trabzon.
- Kokkotas, P., Vlachos, I. and Koulaidis, V. (1998). Teaching the topic of the particulate nature of matter in prospective teachers training courses. *International Journal of Science Education*, 20(3), 291-303.
- Liu, X. and Lesniak, K. M. (2006). Progression in children's understanding of the matter concept from elementary to high school. *Journal of Research in Science Teaching*, 43(3), 320-347.
- Özmen, H., Ayas, A. and Coştu, B. (2002). Determination of the science student teachers' understanding level and misunderstandings about the particulate nature of the matter. *Educational Sciences: Theory and Practice*, 2(2), 507-529.
- Özmen, H. and Kenan, O. (2007). Determination of the Turkish primary students' views about the particulate nature of matter. *Asia-Pacific Forum on Science Learning and Teaching*, 8(1), 1-15.
- Pereira, M. P. and Pestana, M. E. (1991). Pupils' representations of water. *International Journal of Science Education*, 13, 313-319.

- Singer, J. E., Tal, R. and Wu, H. K. (2003). Students' understanding of the particulate nature of matter. *School Science and Mathematics*, 103(1), 28-44.
- Stern, L., Barnea, N. and Shauli, S. (2008). The effect of a computerized simulation on middle school students' understanding of the kinetic molecular theory. *Journal of Science Education and Technology*, 17, 305-315.
- Şahin, Ç. ve Çepni, S. (2012). 5E öğretim modeline dayalı öğretimin öğrencilerin gaz basıncı ile ilgili kavramsal anlamalarına etkisi. *Necatibey Eğitim Fakültesi Elektronik Fen ve Matematik Eğitimi Dergisi (EFMED)*, 6(1), 220-264.
- Tsai, C.-C. (1999). Overcoming junior high school students' misconceptions about microscopic views of phase change: A study of an analogy activity. *Journal of Science Education and Technology*, 8(1), 83-91.
- Türk, F. and Çalık, M. (2008). Using different conceptual change methods embedded within 5e model: a sample teaching of endothermic- exothermic reactions. *Asia-Pacific Forum on Science Learning and Teaching*, 9(1), 1-10.

ÖĞRENCİLERİN FONKSİYON KAVRAMINA İLİŞKİN KAVRAM YANILGILARINA YÖNELİK ÖĞRETMEN YAKLAŞIMLARI

TEACHERS' APPROACHES TO STUDENTS MISCONCEPTIONS ABOUT FUNCTION CONCEPT

Berna TATAROĞLU TAŞDAN
Dokuz Eylül Üniversitesi
berna.tataroglu@deu.edu.tr

Ayten ERDURAN
Dokuz Eylül Üniversitesi
erduranayten@gmail.com

Adem ÇELİK
Dokuz Eylül Üniversitesi
adem.celik@deu.edu.tr

ÖZET: Matematik öğretmenlerinin sahip olması gereken bilgi türlerinden biri pedagojik alan bilgisidir. Pek çok araştırmacı tarafından farklı modellerle ve bileşenlerle ele alınsa da pedagojik alan bilgisi kapsamında hem fikir olunan bilgi bileşenlerinden birisi öğrencileri anlama bilgisidir. Öğrencileri anlama bilgisi; öğrencilerin ön bilgilerinin farkında olmayı, öğrencilerin kavrayışlarını ve nasıl düşündüklerini bilmeyi, öğrencilerin kavram yanlışlarını ve öğrenme güçlüklerini belirlemeyi kapsar. Bu bilgiye sahip olmak öğretmene öğretimini planlamada, uygun kararlar almada ve öğretim uygulamalarını geliştirmede yardımcı olur. Matematikte öğrencilerin en çok yanlışya düştükleri kavramlardan biri de fonksiyon kavramıdır. Temel bir matematiksel kavram olan fonksiyon kavramı trigonometri, limit, süreklilik, türev ve integral gibi pek çok kavram için temel nitelik taşıması nedeniyle oldukça önemlidir. Bu kavram ileri matematik ya da diğer bilim dalları için de gerekli görülmektedir. Bu bağlamda matematik öğretmenlerinin fonksiyon kavramına ilişkin öğrenci düşüncelerini bilmeleri ve öğrencilerin kavram yanlışlarını giderebilmeleri bu kavramın anlamlı öğrenilmesinin sağlanması açısından yarar sağlayacaktır.

Bu araştırmada amaç matematik öğretmenlerinin öğrencilerin fonksiyon kavramına ilişkin kavram yanlışlarına yönelik yaklaşımlarının incelenmesidir. Araştırma bir hizmet içi eğitimin katılımcıları olan sekiz matematik öğretmeni ile gerçekleştirilmiştir. Hizmet içi eğitimde katılımcı öğretmenlerin pedagojik alan bilgilerini geliştirmek hedeflenmiştir. Araştırmada belirli bir grup hakkında konu ile ilgili derinlemesine bilgi edinilmesi amaçlandığından nitel araştırma yöntemlerinden biri olan özel durum çalışması kullanılmıştır. Veriler araştırmacılar tarafından, literatürde belirlenen kavram yanlışlarından yararlanılarak geliştirilen 4 senaryo durumu aracılığıyla toplanmıştır. Öğretmenler senaryo durumlarındaki açık uçlu soruların her birine yazılı olarak yanıt vermişlerdir. Veriler içerik analizi kullanılarak analiz edilmiştir. Araştırmanın bulguları katılımcı matematik öğretmenlerinin öğrencilerin kavram yanlışlarını gidermede çözüm yolu olarak sorularla yönlendirme, karşıt örnekler verme, ön bilgileri hatırlatma ve farklı gösterim şekillerinden yararlanmaya başvurduklarını göstermiştir. Elde edilen sonuçlar matematik öğretmenlerinin öğrencilerin fonksiyon kavramına ilişkin yanlışlarını belirleme ve gidermede olumlu yaklaşımlar sergilediğini göstermiştir.

Anahtar sözcükler: matematik öğretmeni, kavram yanlışlığı, fonksiyon kavramı

ABSTRACT: One type of knowledge that teachers need to have is pedagogical content knowledge. However it is dealt by many researchers with different models and components, knowledge of students' thinking is one of the components that is agreed on. Knowledge of students' thinking include to be aware of students' prior knowledge, to know students' conceptions and how students think, to determine students' misconceptions and learning difficulties. To have this knowledge helps a teacher for planning her/his instruction, appropriate decision making and improving her/his teaching practices. A concept in mathematics which students usually have misconception is function concept. A basic mathematical concept, function concept, is so important because of being a basic for many concepts like trigonometry, limits, continuity, derivatives and integrals. This concept is seen critical for advanced mathematics or other sciences. In this context, when the teachers know students' thinking about function concept and remove their misconceptions, it will contribute a lot to ensure a meaningful learning.

The purpose of this research is examining the mathematics teachers' approaches to students' misconceptions about function concept. The research was realized with eight mathematics teachers that were the participants of

an in-service training. The aim of the training was developing participant teachers' pedagogical content knowledge. Case study, one of the qualitative research methods, was used in the study because of aiming to get in-depth knowledge about the group regarding the subject. Data were collected via 4 scenarios that were developed by the researchers on benefitting the misconceptions reported in the literature. The teachers gave responses to each of the open-ended questions in scenarios. The data were analyzed by using content analysis. Findings of the research showed that the participant mathematics teachers apply routing with questions, giving opposite examples, reminding prior knowledge and drawing on different representations for removing students' misconceptions. The obtained results showed that the mathematics teachers exhibited positive approaches for determining and removing students' misconceptions about function concept.

Key words: mathematics teacher, misconception, function concept

İLKOKUL 1. SINIF ÖĞRENCİLERİNİN DRAMA TEMELLİ ÖĞRETİM İLE TOPLAMA İŞLEMİ İLE İLGİLİ ÖĞRENME SÜREÇLERİNİN İNCELENMESİ

ANALYSIS OF PRIMARY EDUCATION 1ST GRADE STUDENTS' ADDITION LEARNING PROCESSES THROUGH DRAMA BASED EDUCATION

Mesut ÖZTÜRK
Gümüşhane Bilim ve Sanat Merkezi
mesutozturk@live.com

Yaşar AKKAN
Gümüşhane Üniversitesi, Mühendislik Fakültesi
akkanyasar61@gumushane.edu.tr

Abdullah KAPLAN
Atatürk Üniversitesi, Kazım Karabekir Eğitim Fakültesi
akaplan@atauni.edu.tr

Emre OKTAY
Şanlıurfa Halfeti Dergili Ortaokulu
odak_mat@hotmail.com

Muhammet DORUK
Atatürk Üniversitesi, Kazım Karabekir Eğitim Fakültesi
mdoruk@atauni.edu.tr

Tacettin ŞİMŞEK
Atatürk Üniversitesi, Kazım Karabekir Eğitim Fakültesi
tacettinsimsek@atauni.edu.tr

ÖZET:Doğayı anlama çabasının bir sonucu olan ve yapısı gereği soyut prensip ve kuralları içeren matematikte, bu soyut prensiplerin ve kavramların keşfedilmesi, ancak bir takım somut deneyimler yoluyla gerçekleşebilir. Bu nedenle matematikte öğrencinin aktif durumda olduğu drama temelli öğretim yöntemi ile daha anlamlı ve kalıcı öğrenmenin gerçekleşeceği bir öğrenme ortamı yakalama fırsatı öğrencilere sunulabilir. Drama temelli öğretimin ilkökul birinci sınıf öğrencilerinin toplama işlemi ile ilgili öğrenme süreçlerini nasıl etkilediğini ortaya çıkarmayı amaçlayan bu çalışma 2013-2014 eğitim öğretim yılı bahar döneminde yapılmıştır. Bu bağlamda ilkökul birinci sınıf öğrencilerine toplama işlemi ile ilgili altı farklı drama uygulanmış, uygulama esnasında gözlemler yapılmış ve veri kaybı yaşanmaması için kamera kayıt cihazı ile kayıt yapılmış, uygulama sonunda ise öğrencilerle yarı yapılandırılmış mülakatlar yürütülmüştür. Elde edilen verilerden, öğrencilerin drama etkinliklerine katılmada istekli oldukları, toplama işlemini kavramsal olarak anlayabildikleri, toplama işleminin günlük hayatta kullanımının önemli olduğunun farkında oldukları, drama etkinlikleri içinde yer almaktan mutlu oldukları tespit edilmiştir.

Anahtar sözcükler: Drama temelli öğretim, toplama işlemi, ilkökul 1. sınıf, drama

ABSTRACT:In mathematics, which is a result of the efforts to understand nature and which includes abstract principles and rules by nature, discovery of these abstract principals and concepts can be ensured only through some tangible experiences. This is why, with drama based education method, in which student is active in mathematics, it is possible to present a learning environment which ensures more meaningful and permanent learning to students. This study aims at revealing the effect on drama based teaching on primary education 1st grade students' learning processes about addition in mathematics; the study is carried out in 2013-2014 academic year, spring semester. In this context, six different dramas about addition are applied on 1st grade students, observations are done and in order to prevent any loss of information, the process is recorded with camera; after the application, semi-structured interviews with students are carried out. On the basis of these data, it is determined that students are willing to participate in drama activities, they can understand addition conceptually, they are aware of the importance of using addition in daily life and they are happy to participate in drama activities.

Key words: Drama based instruction, addition, primary school 1st grade, drama

MATEMATİKTE ÜSTÜN ZEKÂ VE ÜSTÜN YETENEK KAVRAMLARI ÜZERİNE ALAN YAZIN İNCELEMESİ

Şule GÜÇYETER

Üstün zeka ve üstün yetenek kavramlarına yönelik ilginin artmasıyla birlikte, üstün zekalı ve yetenekli bireylere yönelik sunulacak eğitim-öğretim seçenekleri, eğitim öğretim hizmetlerinin neler olabileceği, en etkili yöntemlere nasıl başvurulacağı da önem kazanmaktadır. Genel alanlarda üstün zekalı ve yetenekli olarak tanı almanın yanında, üstün zeka ve yeteneğin spesifik bir alanda kendini göstermesi ile birlikte farklı disiplinlerde üstün zekalı ve yetenekli olma kavramı da ön plana çıkmaktadır. Üstün zeka ve yeteneğin spesifik olarak kendini gösterdiği en temel alanlardan biri de matematiktir. Matematikte üstün zekalı ve yetenekli bireylerin tanılanmaması, dolayısıyla uygun eğitim fırsatlarıyla karşılaştırılmaması neticesinde bu öğrencilerin yetenek gelişimleri bu durumdan olumsuz etkilenecek hem öğrenci hem toplum için kayıplara neden olabilmektedir. Bu çalışmada, matematik alanında üstün zeka ve yetenek kavramlarıyla ilgili alan yazında yer alan tanımlar ve bu kavramlara yönelik alan uzmanlarının bakış açıları incelenecektir. Bu noktadan hareketle matematik alanında üstün zeka ve yetenekle ilgili alan uzmanlarının önemli gördüğü özellikler ile bu öğrencilerle etkileşimde olan öğretmenler, eğitimciler, akademisyenler vb. ilgililerin bakış açılarını inceleyen araştırmalardan derlenen önemli bulgular da paylaşılacaktır.

Çalışma matematikte üstün zekâlı ve yetenekli bireylere yönelik farkındalık oluşturması; bu alanda yetenekli bireylerin doğru tanılanması; matematikte yetenekli bireylerin yeteneklerini geliştirecek uygun eğitim fırsatlarıyla buluşturulması, öğretmen eğitim programlarında bu alanda yetenekli bireyler için yapılması gerekenler üzerine yeni araştırmaları teşvik etmesi açılarından önem arz etmektedir. Alan yazın incelemesi neticesinde ulaşılan sonuçlar kongre katılımcılarıyla paylaşılarak tartışılacaktır.

Anahtar Kelimeler: matematikte üstün zeka, matematikte üstün yetenek

oooooooooooooooooooo

ABOUT MATHEMATICS SUPERIOR INTELLIGENCE AND SUPERIOR SKILL CONCEPT LITERATURE SURVEY

Şule GÜÇYETER

Üstün zeka ve üstün yetenek kavramlarına yönelik ilginin artmasıyla birlikte, üstün zekalı ve yetenekli bireylere yönelik sunulacak eğitim-öğretim seçenekleri, eğitim öğretim hizmetlerinin neler olabileceği, en etkili yöntemlere nasıl başvurulacağı da önem kazanmaktadır. Genel alanlarda üstün zekalı ve yetenekli olarak tanı almanın yanında, üstün zeka ve yeteneğin spesifik bir alanda kendini göstermesi ile birlikte farklı disiplinlerde üstün zekalı ve yetenekli olma kavramı da ön plana çıkmaktadır. Üstün zeka ve yeteneğin spesifik olarak kendini gösterdiği en temel alanlardan biri de matematiktir. Matematikte üstün zekalı ve yetenekli bireylerin tanılanmaması, dolayısıyla uygun eğitim fırsatlarıyla karşılaştırılmaması neticesinde bu öğrencilerin yetenek gelişimleri bu durumdan olumsuz etkilenecek hem öğrenci hem toplum için kayıplara neden olabilmektedir. Bu çalışmada, matematik alanında üstün zeka ve yetenek kavramlarıyla ilgili alan yazında yer alan tanımlar ve bu kavramlara yönelik alan uzmanlarının bakış açıları incelenecektir. Bu noktadan hareketle matematik alanında üstün zeka ve yetenekle ilgili alan uzmanlarının önemli gördüğü özellikler ile bu öğrencilerle etkileşimde olan öğretmenler, eğitimciler, akademisyenler vb. ilgililerin bakış açılarını inceleyen araştırmalardan derlenen önemli bulgular da paylaşılacaktır.

Çalışma matematikte üstün zekâlı ve yetenekli bireylere yönelik farkındalık oluşturması; bu alanda yetenekli bireylerin doğru tanılanması; matematikte yetenekli bireylerin yeteneklerini geliştirecek uygun eğitim fırsatlarıyla buluşturulması, öğretmen eğitim programlarında bu alanda yetenekli bireyler için yapılması gerekenler üzerine yeni araştırmaları teşvik etmesi açılarından önem arz etmektedir. Alan yazın incelemesi neticesinde ulaşılan sonuçlar kongre katılımcılarıyla paylaşılarak tartışılacaktır.

Keywords: In mathematics, superior intelligence, superior ability in mathematics

7. SINIF ÖĞRENCİLERİNİN KESİRLERDE SIRALAMA KONUSUNDAKİ KAVRAM YANILGILARI

İbrahim ÇETİN

Fatih KALECİ

Ortaokul öğrencilerinin matematik dersinde karşılaştıkları soyut kavramlardan bir tanesi de kesir kavramıdır. Konunun soyut olması, bu konunun öğretiminde birçok güçlüklerle karşılaşılmasına neden olmuştur. Literatüre bakıldığında öğrencilerin kesirlerle ilgili sahip oldukları birçok yanlışlığı görmek mümkündür. Kesir öğretiminin özensiz bir yaklaşımla verilmesi bu kavram yanlışlarının ortaya çıkmasında en önemli nedenlerden biri olduğu gözlenmiştir (Van de Walle., 2004). Maalesef bir an önce işlem yaptırma telaşıyla, özensizce ve kavramsal alt yapısı verilmeden öğretilen kesir kavramı üzerinde en fazla yanlışlığın görüldüğü matematiksel kavramlardan bir tanesidir.

Programa bakıldığında 1. ve 2. Sınıflarda çeyrek ve yarım kavramlarının verilmesiyle başlayan kesir eğitimi, 3. Sınıftan 4. Sınıfa doğru sayı doğrusu üzerinde kesirlerin gösterilip, sıralanması ile devam eder. Kesirlerde sıralama konusu ile ilk defa öğrenciler 3. Sınıfta karşılaşmakta ve daha sonrasında ise sıralama konusu gerek sayı doğrusunda gerekse de şekillerin üzerinde somutlaştırılarak öğrenilmesiyle sonraki sınıflarda da öğretimi yapılarak programdaki yerini almaktadır. Kesirlerin karşılaştırılması ile ilgili olarak birçok öğrencinin verilen iki kesirden rakamları büyük olanın değerine göre daha büyük olacağı (Hart ve ark., 1980) ve paya bakmaksızın paydanın büyümesi ile kesrin küçüleceği bilgisi ile sadece paydaya bakarak kesirlerin karşılaştırılması (Haser ve Ubuz, 2000) şeklinde kavram yanlışlarına sahip oldukları belirlenmiştir.

Bu çalışmada kesirlerin karşılaştırılmasında görülen kavram yanlışlarına yeni biri daha eklenecektir. 2013-2014 yılının ilk döneminde Konya İli Karatay İlçesinde 32 tane 7. Sınıf öğrencisinin katılımı ile gerçekleşen çalışmada nitel araştırma tekniklerinden görüşme tekniği ve doküman incelemesi tekniği kullanılmıştır. Öğrencilere günlük hayatla ilgili bir problem, araba benzin göstergesi, üzerinde verilmeyen noktaların kesir değerinin ne olduğu sorulmuştur. Bu soruyu yanlış cevaplayan 27 öğrencinin verdiği farklı cevaplar ve sahip oldukları kavram yanlışlarına konferanstaki sunumda ayrıntılı değinilecektir.

Anahtar Kelimeler: Matematik, Kesir, Kavram Yanılgısı

oooooooooooooooo

ENGINEERING STUDENTS IRRATIONAL NUMBER KNOWLEDGES

İbrahim ÇETİN

Fatih KALECİ

Ortaokul öğrencilerinin matematik dersinde karşılaştıkları soyut kavramlardan bir tanesi de kesir kavramıdır. Konunun soyut olması, bu konunun öğretiminde birçok güçlüklerle karşılaşılmasına neden olmuştur. Literatüre bakıldığında öğrencilerin kesirlerle ilgili sahip oldukları birçok yanlışlığı görmek mümkündür. Kesir öğretiminin özensiz bir yaklaşımla verilmesi bu kavram yanlışlarının ortaya çıkmasında en önemli nedenlerden biri olduğu gözlenmiştir (Van de Walle., 2004). Maalesef bir an önce işlem yaptırma telaşıyla, özensizce ve kavramsal alt yapısı verilmeden öğretilen kesir kavramı üzerinde en fazla yanlışlığın görüldüğü matematiksel kavramlardan bir tanesidir.

Programa bakıldığında 1. ve 2. Sınıflarda çeyrek ve yarım kavramlarının verilmesiyle başlayan kesir eğitimi, 3. Sınıftan 4. Sınıfa doğru sayı doğrusu üzerinde kesirlerin gösterilip, sıralanması ile devam eder. Kesirlerde sıralama konusu ile ilk defa öğrenciler 3. Sınıfta karşılaşmakta ve daha sonrasında ise sıralama konusu gerek sayı doğrusunda gerekse de şekillerin üzerinde somutlaştırılarak öğrenilmesiyle sonraki sınıflarda da öğretimi yapılarak programdaki yerini almaktadır. Kesirlerin karşılaştırılması ile ilgili olarak birçok öğrencinin verilen iki kesirden rakamları büyük olanın değerine göre daha büyük olacağı (Hart ve ark., 1980) ve paya bakmaksızın paydanın büyümesi ile kesrin küçüleceği bilgisi ile sadece paydaya bakarak kesirlerin karşılaştırılması (Haser ve Ubuz, 2000) şeklinde kavram yanlışlarına sahip oldukları belirlenmiştir.

Bu çalışmada kesirlerin karşılaştırılmasında görülen kavram yanlışlarına yeni biri daha eklenecektir. 2013-2014 yılının ilk döneminde Konya İli Karatay İlçesinde 32 tane 7. Sınıf öğrencisinin katılımı ile gerçekleşen çalışmada nitel araştırma tekniklerinden görüşme tekniği ve doküman incelemesi tekniği kullanılmıştır. Öğrencilere günlük hayatla ilgili bir problem, araba benzin göstergesi, üzerinde verilmeyen noktaların kesir değerinin ne olduğu sorulmuştur. Bu soruyu yanlış cevaplayan 27 öğrencinin verdiği farklı cevaplar ve sahip oldukları kavram yanlışlarına konferanstaki sunumda ayrıntılı değinilecektir.

Keywords: Mathematics, Fractions, Misconceptions

THE IMPORTANCE OF LIFELONG LEARNING FOR TURKEY AND EU RELATIONSHIP IN THE GLOBAL AND CHANGING WORLD

Sahire DOGRU

Sirnak Universitesi/
University of Birmingham

sahire.dogru@gmail.com

ABSTRACT: The relationships between Turkey and European Union has a longer process of crucial discussion to become a member of European Union for Turkey over two decades. There is not enough and satisfied improvement of progress during years. However, Turkey's hope to entering the EU has not been ended with help of globalizing networks of communication tools, social media, technologic improvements that helps lifelong learning. Turkey needs a lots projects for the EU Acquis throughout the adaptation process to represent Turkey's performance. Also, social awareness and adaptation is required by Turkish citizenship towards full membership of EU. Lifelong learning, technology and social media has substantial contribution to develop projects concerned with the public and civil society for introducing EU to more masses in Turkey, increasing efficiency of project and allowing better understanding and awareness of EU progress and objectives. This paper emphasizes that the importance of lifelong learning programs, projects and initiatives for Turkey to attend the EU. Because lifelong learning provide achievement in field like personal fulfillment, active citizenship, social inclusion, employability and adaptability.

Keywords : Lifelong Learning, EU and Turkey, active citizenship, democracy and human rights, technology

INTRODUCTION

Lifelong Learning is described as by European Commission as :

All learning activities undertaken throughout life with the aim of improving knowledge, skills and competence within a personal, civic, social and employment-related perspective.

Lifelong learning has a crucial impact on personal development for learning societies. In the modern world that is becoming a global village, economies and societies support and encourage people to continue learning activities throughout all their life because of required skills and qualifications they will need in this century. Lifelong learning is quite related to the globalization, the rise of new information with technologies and the aging societies. Knowledge and information are a global power in the modern age. Over more than five hundred years, nation's and country's success and failure or destiny depend on technical skill, acquire knowledge, technology, science, management of knowledge and their economy. Therefore, societies and economies need to become a knowledge based structure. Furthermore, the knowledge given in the years of compulsory schooling is enough for this age. The role of lifelong learning is to provide opportunities for adults to be educated as active citizenship, self-realizations in liberal democracy.

EUROPE AND LIFELONG LEARNING

UNESCO with international congress has emphasized importance of relationship of lifelong learning and adult education in 1997. Also, lifelong learning has a great concern with social cohesion, community building, individual development. Moreover, the development of projects according to the UK government's Green Paper on lifelong learning mentions the importance of lifelong learning (Field, J., & Leicester, M., 2000, p. 2). In addition, there has been increasing interest in the development of lifelong learning opportunities by policy formers and makers in industrialized countries.

Lifelong learning is a popular field in EU educational policy. There has been lots of meeting and discourses about lifelong learning since the 1970s. Also, it has become a important topic in international debates from the early to mid-1970s. Most of the lifelong learning debates was related to the protection of intergovernmental organization such as the Council of Europe, the Organization for Economic Cooperation and Development (OECD) and United Nations Educational, Social and Cultural Organizations (UNESCO) before mid-1970s. Lifelong learning had humanistic origin and ideals at that time. From the 1970s to 1990s, economic perspective of lifelong learning had considered as a significant topic with the economic and petrol crisis, its consequences and increasing unemployment. However, the popularity of this area has increased with great interest in 1990s. The main strategies, concepts and objectives of lifelong learning policies in EU education and training program has described and provided essential critical thoughts on them. The main origin shift away

from humanistic ideals towards economic objectives and utilitarian (Dehmel, A., 2006). Political, social, economic and technological view of lifelong learning besides educational side has become important concepts and objectives. According to EU's integrated lifelong learning programs has been separated four general section :

- Comenius (School Education)
- Erasmus (Higher Education)
- Leonardo Da Vince (Vocational and Training)
- Grundtvig (Adult Education)

Education and training programs and policy concepts are still increasing with great interest in the form of formal, informal and non-formal learning.

Each country has opportunity and freedom to follow and develop their way for lifelong learning. Turkey needs to develop and perform the policies about lifelong learning programs for EU adaptation process. Turkey is facing lots of problems of the past because of heritage of the distant past related to Ottoman's Empire time and current past associated with neighbor of Turkey and the democracy and human rights.

EUROPEAN COMMISSION AND TURKEY

Turkey 2013 progress report prepared by European Commission involves contributions of European Parliament reports, the EU Member States, the government of Turkey and international and non-governmental organization.

There are lots of cooperation area such as participation in EU programs, energy, trade, counter terrorism, political reforms, foreign policy , visas, policy, mobility and migration. Also, fundamental rights, judiciary system and progress reports have quite important concepts for the Commission. There are too much area for discussion between EU and Turkey relationship :

- *Political Criteria and Enhanced Political Dialogue*
 - ✓ Democracy and the rule of law
 - ✓ Parliament
 - ✓ Judiciary and fundamental rights
 - ✓ Government
 - ✓ Ombudsman
 - ✓ Public administration
 - ✓ Civilian oversight of the security forces
 - ✓ Civil society
 - ✓ Judicial system
 - ✓ Fight against corruption
 - ✓ Fight against organized crime
- *Human Rights and The Protection of Minorities*
 - ✓ Situation in the east and south-east
 - ✓ Refugees and internationally displaced persons
- *Regional Issues and International Obligations*
 - ✓ Cyprus
 - ✓ Peaceful settlement of border disputes
 - ✓ Regional Cooperation
- *Economic Criteria*
 - ✓ The existence of a functioning market economy
 - ✓ The capacity of cope with competitive pressure and market forces within the Union
 - ✓ Economic integration with the EU
- *Ability to take on the Obligations Of Membership*

- ✓ Free movement of goods
- ✓ Freedom of movement for workers
- ✓ Right of establishment and freedom to provide services
- ✓ Free movement of capital
- ✓ Public procurement
- ✓ Company law
- ✓ Intellectual property law
- ✓ Competition policy
- ✓ Financial services
- *Information Society and Media*
 - ✓ Electronic communication and information and communications technologies (ICT)
 - ✓ Information Society Services
 - ✓ Audiovisual policy
- *Agriculture and Rural Development*
 - ✓ Organic farming
 - ✓ Quality policy
 - ✓ Common market organization
Fisheries
- Food safety, veterinary and phytosanitary policy
 - ✓ General food safety
 - ✓ Veterinary policy
 - ✓ Food safety rules
 - ✓ Phytosanitary policy
 - ✓ Genetically modified organisms
- Transport Policy
 - ✓ Road and rail transport
 - ✓ Air and Maritime transport
- Energy
 - ✓ Security and supply
 - ✓ International Energy Market
 - ✓ Renewable Energy
 - ✓ Energy Efficiency
 - ✓ Nuclear Safety and radiation protection
- *Taxation*
- *Economic and Monetary Policy*
- *Statistics*
- *Social Policy and Employment*
- *Enterprise and Industrial Policy*
- *Transport European Networks*
- *Regional policy and Coordination of Structural Instruments*

- *Judiciary and Fundamental Rights*

- *International Human Rights Instruments*
 - ✓ Freedom of Assembly
 - ✓ Freedom of Expression
 - ✓ Prevention of torture and ill-treatment
 - ✓ Prison System
 - ✓ Freedom of Association
 - ✓ Freedom of thoughts, conscience and religion
 - ✓ Women's rights and gender equality
 - ✓ Children's rights
 - ✓ Labour and Trade Unions Rights
 - ✓ Property rights
 - ✓ Protection of Personal Data

- *Justice, Freedom and Security*
- *Science and Research*
- *Education and Culture*
- *Environment and Climate Change*
- *Consumer and Health Protection*
- *Customs Union*
- *External relation*
- *Foreign, security and Defence Policy*
- *Financial Control, Financial and Budgetary Provisions*

In many areas above list, developments and improvements are not enough for EU's standards according to EU's report for Turkey in 2013. In addition, no progress is reported in many areas. Turkey needs to take steps to become a member of European Union. There are lots of criticized issue and topic related to the list above. A number of important reforms are required to reach European Standards. Also, current law constitution is insufficient to give answer and perform new situation with EU's progress. Government should continue to reform further for democratization and take a number of steps in the human rights and the fundamental right . It is not possible real democratic system and management without the active citizenship and active civil societies. The growing and active societies in Turkey must have important role to establish Turkey's human rights mechanism and institutions. The president and government must continue to support political and democratic reforms for Turkey membership. Lifelong learning is a key word for active citizenship and to perform all reforms in real platform among people who live in Turkey. Further democratization and political reforms are should be maintained to reach the democratic standards of European Union. The coordination and cooperation among civil societies, business and government are really important issue for good progress in terms of establishing to real life all reforms.

After complication of all reforms, laws, rules, reform judicial and democratization package which are required to become a member of EU for Turkey, the main role depend on civil societies, universities, media, educationist and trainer to perform rules in level of public area. First thing for this process, all rules and reforms should be taught all people and encourage them to reform in their life. For these reasons, the lifelong learning has a quite important role in the process of membership of EU for Turkey. To become membership of EU for Turkey is significant adaptation process and the life learning has a great impact on public and adult understanding of this process to perform all required forms for EU.

All the developed countries in Europe and the United States are trying to become a society of lifelong learner as soon as possible (Lundmark, 2002). If Turkey gets achieve to become a society of lifelong learners with the help of the lifelong learning principle, technology and media in the changing and global world, the major important part of the adaptation process must be completed. Turkey must be a place for lifelong learner.

Information and knowledge related to EU should be available in all major learning setting such as schools, universities, workplace, free choice venues with helping of technology to make all information and EU's concept more accessible. Projects, working throughout public based organizations, gets civil societies involved in lifelong learning organization will give really successful results for the relationship between EU and Turkey.

To involve EU's project, as well as establishing rules reforms and law towards EU' membership will essential steps towards real success in the process.

CONCLUSION

The major part of population in Turkey is living in the rural area, only real access to people living in rural area is possible with media support, technological tools, volunteer organizations, videos, computers. Societies in Turkey needs to better support efforts for lifelong learning any time, anywhere during the life span for the adaptation process between the EU and Turkey. In addition, a better cooperation among politicians, economists, sociologist, educationists, ministries, civil societies, municipalities, governorships, academicians will provide a huge contribution to Turkey's ongoing application for becoming a full member of the EU. Turkey's hope toward the EU's standards for the all field is still continue and Turkey might be a really good role model on the way of the democracy and the fundamental and human rights for Middle East counties and others.

REFERENCES

- Field, J. & Leicester, M. (2000). Lifelong Learning Education across the lifespan: Lifelong learning or permanent schooling. New York, USA: RoutledgeFalmer
- Dehmel, A., (2006). Making a European area of lifelong learning a reality? Some critical reflections on the European Union's lifelong learning policies. *Comparative education*. 42 (1), 49-62.
- Lundmark, C. (2002). Lifelong Learning : American Institute of Biological Sciences. *Oxford Journals*. 52 (4), 325 .
- Turkey 2013 Progress Report (Communication From The Commission To The European Parliament And The Council) Available at : http://www.abgs.gov.tr/files/strateji/tr_rapport_2013_en.pdf (Accessed 11 April 2014)
- Shabnam, R., S., (2011). Turkey and the European Union : A Step Too Far ? An Investigation into the Journey of Turkey's Road to EU Membership. University of Birmingham, Birmingham, United Kingdom

9-12. SINIF BİYOLOJİ DERSLERİNDE BİLİM İNSANLARINDAN YARARLANMA

Ela Ayşe KÖKSAL

Bilim insanına yönelik algılar ve zihinsel imajlar öğrencilerin fen bilimlerine yönelik tutumları ve gelecekteki meslek seçimleri üzerinde etkilidir. Bilim ve bilim insanına yönelik imajlar çeşitli okul içi ve dışı kaynaklarca belirlenmektedir. Ders kitapları ve öğretim etkinlikleri bu imajların olumlu olmasına katkı sağlayacak özelliklere sahip olmalıdır. Bu çalışmanın amacı 9-12. sınıf biyoloji derslerinde bilim insanlarından ne şekilde yararlandığını incelemektir. Bu amaç için ders kitaplarında bulunan bilim insanı gösterimleri incelenecek ve bilim insanlarının biyoloji dersinde ne şekilde vurgulandığı ile ilgili olarak da biyoloji öğretmenleriyle yapılacak yarı yapılandırılmış mülakatlara başvurulacaktır. Ayrıca biyoloji derslerinde bilim insanlarına nasıl yer verildiğiyle ilgili olarak görüşme yapılan öğretmenlerin sınıflarında yapılandırılmış gözlemler yapılacaktır. Bu şekilde farklı veri toplama teknikleriyle veri çeşitlemesi yapılarak araştırma bulgularının güvenilirliği artırılmaya çalışılacaktır.

Anahtar Kelimeler: Bilim tarihi, bilim insanı, lise biyoloji

oooooooooooooooooooo

9-12. SINIF BİYOLOJİ DERSLERİNDE BİLİM İNSANLARINDAN YARARLANMA

Ela Ayşe KÖKSAL

Bilim insanına yönelik algılar ve zihinsel imajlar öğrencilerin fen bilimlerine yönelik tutumları ve gelecekteki meslek seçimleri üzerinde etkilidir. Bilim ve bilim insanına yönelik imajlar çeşitli okul içi ve dışı kaynaklarca belirlenmektedir. Ders kitapları ve öğretim etkinlikleri bu imajların olumlu olmasına katkı sağlayacak özelliklere sahip olmalıdır. Bu çalışmanın amacı 9-12. sınıf biyoloji derslerinde bilim insanlarından ne şekilde yararlandığını incelemektir. Bu amaç için ders kitaplarında bulunan bilim insanı gösterimleri incelenecek ve bilim insanlarının biyoloji dersinde ne şekilde vurgulandığı ile ilgili olarak da biyoloji öğretmenleriyle yapılacak yarı yapılandırılmış mülakatlara başvurulacaktır. Ayrıca biyoloji derslerinde bilim insanlarına nasıl yer verildiğiyle ilgili olarak görüşme yapılan öğretmenlerin sınıflarında yapılandırılmış gözlemler yapılacaktır. Bu şekilde farklı veri toplama teknikleriyle veri çeşitlemesi yapılarak araştırma bulgularının güvenilirliği artırılmaya çalışılacaktır.

Keywords: The history of science, scientists, high school biology

UYARLANMIŞ BİRİNCİL LİTERATÜRE DAYALI YÖNTEMİN BİYOLOJİ ÖĞRETMEN ADAYLARININ BİLİM İNSANI İMAJLARI ÜZERİNE ETKİSİ

THE EFFECT OF ADAPTED PRIMARY LITERATURE ON BIOLOGY PROSPECTIVE TEACHERS' IMAGES OF THE SCIENTISTS

Sultan ÇIKRIK
Gazi Üniversitesi
sultanaltunsoy@gazi.edu.tr

Mustafa YEL
Gazi Üniversitesi
musyel@gazi.edu.tr

ÖZET :Bu araştırmanın amacı, uyarlanmış birincil literatüre dayalı yöntemin biyoloji öğretmen adaylarının bilim insanı imajları üzerine etkisini incelemektir. Araştırmanın çalışma grubunu, 2013-2014 eğitim yılında Gazi Eğitim Fakültesi, Biyoloji Öğretmenliği programında 3. sınıfa kayıtlı 26 öğretmen adayı oluşturmuştur. Araştırma ön-son test tek gruplu deneysel desen modelinde gerçekleştirilmiştir. Araştırmada, öğretmen adaylarının bilim insanı imajlarının belirleyebilmek için, Chambers (1983) tarafından geliştirilen *Bir Bilim İnsanı Çiz (DAST)* ölçeği kullanılmıştır. Deneysel uygulamada sitoloji alanında 6 tane uyarlanmış bilimsel makale kullanılmıştır. Araştırmanın sonucunda, öğrencilerin bilim insanları ile ilgili olarak laboratuvar önlüklü, gözlüklü, sadece çalışan ve kendisini işine adan ve erkek bilim insanı gibi imajları benimsedikleri gözlenmiştir. Deneysel uygulama sonucunda, cinsiyet ve kullanılan laboratuvar araçları gibi bilim insanı imajı kategorilerinde değişiklikler gözlenmiştir.

Anahtar sözcükler: uyarlanmış birincil literatür, bilim insanı imajı, öğretmen adayı, sitoloji, DAST

ABSTRACT: The aim of this study, to investigate the effect of adapted primary literature on biology prospective teachers' images of the scientists. The sample of this study includes 26 prospective teachers from 3rd grade in Gazi Faculty of Education, Biology Education Department in the educational year of 2013-2014. The research was conducted in the pre-post test with single group design of experimental research model. In the research, to determine the prospective teachers' images of the scientists, *DAST (Draw a Scientist)* test developed by Chambers was used. Six adapted scientific articles in the cytology were used in experimental implementation. As a result of the study, it is observed that the students adopt images about scientists such as scientists with lab coats, glasses, just working and dedicating themselves to the work, and male scientists. As a result of the experimental implementation, changes were observed in categories of images of scientists, such as gender and use laboratory tools.

Key words: adapted primary literature, images of the scientists, prospective teacher, cytology, DAST

STUDENTS' OPINIONS ABOUT THE ACTIVITIES BASED ON CONCEPTUAL CHANGE STRATEGIES

Assist. Prof. Dr. Gliz AYDIN
Muęla Sıtkı Koçman University
Faculty of Education
gulizaydin@gmail.com

Assoc. Prof. Dr. Ali Gnay BALIM
Dokuz Eyll University
Buca Faculty of Education
agunay.balim@deu.edu.tr

This study has been implemented in a secondary school in Izmir, Turkey. By means of the conceptual change strategies based on constructivist approach, students were taught the unit of "Cell Division and Heredity"; from the curriculum of 8th grade Science and Technology course. Students in the control group were taught along with the activities in the Science and Technology Curriculum; and students in the experimental group were taught with activities based on the constructivist approach (such as conceptual change texts, concept maps, mind maps, concept cartoons, analogies and models). The experimental study lasted for 8 weeks. Semi-structured interviews were conducted on the experimental group to understand their opinions about the method practiced. 8 students from the experimental group were interviewed and the interviews were recorded with the permissions of the students. Later, the interviews were written down and their qualitative analysis was made. The questions asked to students, the categories formed based on their answers, percentages and frequencies regarding these categories and students' statements are presented in tables. It has been observed that students find learning the lessons with techniques based on conceptual change strategies more useful and they also think that not only the activities that they did were educative and fun but also they would like to study the other units in Science lesson through similiar activities.

Key words: student opinions, science education, conceptual change strategies

BİYOLOJİ ÖĞRETMEN ADAYLARININ ORGAN NAKLİ VE BAĞIŞI KONUSUNA BAKIŞ AÇILARININ BELİRLENMESİ VE DEĞERLENDİRİLMESİ

Banu Çiçek SEYHAN

Tuğba TAFLI

Aysel TEMELLİ

Bu araştırma; günümüzde toplumun en çok bilinçlendirilmesi gereken konulardan birisi olan organ bağıışı konusunda geleceğin nesillerine eğitim verecek öğretmen adaylarının bu konudaki düşüncelerini belirlemek amacıyla yapılmıştır. Araştırmanın çalışma grubunu Gazi Üniversitesinde ve Atatürk Üniversitesinde Biyoloji Öğretmenliği bölümlerinde okuyan 2., 3., 4. ve 5. Sınıflar oluşturmaktadır. Araştırmada veri toplama aracı olarak Sarıtaş ve Köşgeroğlu (2005) tarafından geliştirilen 5’li likert ölçeği olarak “Öğrencilerin Organ Nakli ve Bağıışına Yönelik Algıları Formu” kullanılmıştır. Ayrıca öğrencilere, bazı demografik özellikleri ile organ bağıışına ait bilgi sahip olma durumları, bilgilerin nereden elde edildiği ve daha önce organ naklinde bulunup bulunmadığına ve buna ait sebepleri öğrenmeye yönelik de çeşitli sorular yönlendirilmiştir. Verilerin analizinde SPSS 15.0 paket programı kullanılmıştır. Elde edilen verilere göre her iki üniversitenin Biyoloji Öğretmenliği bölümlerinde okuyan öğrencilerin büyük çoğunluğu organ nakli ve bağıışı konusunda yeterli bilgiye kısmen sahip olduklarını ve bu bilgilere en çok televizyondan ve internetten ulaştıklarını belirtmişlerdir. Öğrencilerin büyük bir çoğunluğu organ bağıışında bulduklarını veya bulunmak istediklerini ve bunu istemelerindeki neden olarak da en çok bir insanın yaşamasını sağlamak olduğu belirtilmiştir. Araştırmanın 5’li likert verileri demografik özellikler de dikkate alınarak farklı değişkenlere göre sonuçlar frekans ve yüzdelikler verilerek değerlendirilmeleri yapılmıştır.

Anahtar Kelimeler: Öğretmen Adayları, Organ Nakli ve Bağıışı, Bakış Açısı

oooooooooooooooooooo

BİYOLOJİ ÖĞRETMEN ADAYLARININ ORGAN NAKLİ VE BAĞIŞI KONUSUNA BAKIŞ AÇILARININ BELİRLENMESİ VE DEĞERLENDİRİLMESİ

Banu Çiçek SEYHAN

Tuğba TAFLI

Aysel TEMELLİ

Bu araştırma; günümüzde toplumun en çok bilinçlendirilmesi gereken konulardan birisi olan organ bağıışı konusunda geleceğin nesillerine eğitim verecek öğretmen adaylarının bu konudaki düşüncelerini belirlemek amacıyla yapılmıştır. Araştırmanın çalışma grubunu Gazi Üniversitesinde ve Atatürk Üniversitesinde Biyoloji Öğretmenliği bölümlerinde okuyan 2., 3., 4. ve 5. Sınıflar oluşturmaktadır. Araştırmada veri toplama aracı olarak Sarıtaş ve Köşgeroğlu (2005) tarafından geliştirilen 5’li likert ölçeği olarak “Öğrencilerin Organ Nakli ve Bağıışına Yönelik Algıları Formu” kullanılmıştır. Ayrıca öğrencilere, bazı demografik özellikleri ile organ bağıışına ait bilgi sahip olma durumları, bilgilerin nereden elde edildiği ve daha önce organ naklinde bulunup bulunmadığına ve buna ait sebepleri öğrenmeye yönelik de çeşitli sorular yönlendirilmiştir. Verilerin analizinde SPSS 15.0 paket programı kullanılmıştır. Elde edilen verilere göre her iki üniversitenin Biyoloji Öğretmenliği bölümlerinde okuyan öğrencilerin büyük çoğunluğu organ nakli ve bağıışı konusunda yeterli bilgiye kısmen sahip olduklarını ve bu bilgilere en çok televizyondan ve internetten ulaştıklarını belirtmişlerdir. Öğrencilerin büyük bir çoğunluğu organ bağıışında bulduklarını veya bulunmak istediklerini ve bunu istemelerindeki neden olarak da en çok bir insanın yaşamasını sağlamak olduğu belirtilmiştir. Araştırmanın 5’li likert verileri demografik özellikler de dikkate alınarak farklı değişkenlere göre sonuçlar frekans ve yüzdelikler verilerek değerlendirilmeleri yapılmıştır.

Keywords: Teacher candidates, Organ Transplantation and Donation, Perspective

AKILLI TAHTA KULLANIMININ ÖĞRENCİLERİNİN MATEMATİK VE GEOMETRİ ÖZ-YETERLİLİK DÜZEYLERİNE ETKİSİ

Fatih KALECİ

Habip Mehmet SEVGI

İbrahim ÇETİN

ÖZET: Bu araştırmanın amacı, akıllı tahta kullanımının öğrencilerinin matematik ve geometri derslerine yönelik sahip oldukları öz-yeterlilik inanç düzeylerine etkisini belirlemektir. Çalışmanın gerçekleşmesinde ön test-son test kontrol gruplu yarı deneysel desen modelinden yararlanılmıştır. Araştırmanın çalışma grubunu, 2013-2014 eğitim-öğretim yılında Konya ilindeki bir devlet okulunda 10. Sınıf düzeyinde eğitim gören 68 öğrenci oluşturmaktadır. Araştırma için 10. Sınıf matematik ders programında yer alan “İkinci Dereceden Denklemlerin Grafiği” konusu ve geometri ders programında yer alan “Doğrular” konusu seçilmiştir. Bu amaçla 3 hafta süren uygulamada, 34 öğrencinin yer aldığı deney grubunda akıllı tahta kullanılarak ders işlenmiş, diğer 34 öğrencinin yer aldığı kontrol grubunda ise geleneksel öğretim yöntemleri kullanılmıştır. Araştırmada verilerin toplanması aşamasında öğrencilerin matematik dersine karşı özyeterlilik düzeylerini belirlemek amacıyla, Umay (2001) tarafından geliştirilmiş olan “Matematiğe Karşı Öz-yeterlik Algısı Ölçeği” ve öğrencilerin geometriye yönelik öz yeterlik inanç düzeylerini belirlemek amacıyla da Cantürk-Günhan ve Başer’in (2007) geliştirmiş oldukları “Geometri Öz-yeterlik İnanç Ölçeği” kullanılmıştır. Verilerin analizinde betimsel istatistiklerden, t-testinden ve tek yönlü varyans analizi (ANOVA) yöntemlerinden yararlanılmıştır. Veriler, SPSS 19.0 istatistik paket programı kullanılarak analiz edilmiştir.

Araştırma sonuçlarına göre, uygulama öncesinde deney ve kontrol gruplarındaki öğrencilerin matematik dersine karşı öz-yeterlilik algıları ve geometri dersine yönelik öz-yeterlilik inanç puanları arasında anlamlı bir farklılık bulgulanmazken, yapılan uygulama sonrasında gruplardaki öğrencilerin matematik dersine karşı öz-yeterlilik algıları ve geometri dersine yönelik öz-yeterlilik inanç puanları arasında deney grubu lehine istatistiksel olarak anlamlı bir farklılık tespit edilmiştir.

Anahtar Kelimeler: Akıllı Tahta, Matematik Eğitimi, Öz-yeterlilik, Matematiğe Karşı Öz-yeterlik Algısı, Geometriye Yönelik Öz-Yeterlik.

oooooooooooooooooooo

AKILLI TAHTA KULLANIMININ ÖĞRENCİLERİNİN MATEMATİK VE GEOMETRİ ÖZ-YETERLİLİK DÜZEYLERİNE ETKİSİ

Fatih KALECİ

Habip Mehmet SEVGI

İbrahim ÇETİN

ÖZET: Bu araştırmanın amacı, akıllı tahta kullanımının öğrencilerinin matematik ve geometri derslerine yönelik sahip oldukları öz-yeterlilik inanç düzeylerine etkisini belirlemektir. Çalışmanın gerçekleşmesinde ön test-son test kontrol gruplu yarı deneysel desen modelinden yararlanılmıştır. Araştırmanın çalışma grubunu, 2013-2014 eğitim-öğretim yılında Konya ilindeki bir devlet okulunda 10. Sınıf düzeyinde eğitim gören 68 öğrenci oluşturmaktadır. Araştırma için 10. Sınıf matematik ders programında yer alan “İkinci Dereceden Denklemlerin Grafiği” konusu ve geometri ders programında yer alan “Doğrular” konusu seçilmiştir. Bu amaçla 3 hafta süren uygulamada, 34 öğrencinin yer aldığı deney grubunda akıllı tahta kullanılarak ders işlenmiş, diğer 34 öğrencinin yer aldığı kontrol grubunda ise geleneksel öğretim yöntemleri kullanılmıştır. Araştırmada verilerin toplanması aşamasında öğrencilerin matematik dersine karşı özyeterlilik düzeylerini belirlemek amacıyla, Umay (2001) tarafından geliştirilmiş olan “Matematiğe Karşı Öz-yeterlik Algısı Ölçeği” ve öğrencilerin geometriye yönelik öz yeterlik inanç düzeylerini belirlemek amacıyla da Cantürk-Günhan ve Başer’in (2007) geliştirmiş oldukları “Geometri Öz-yeterlik İnanç Ölçeği” kullanılmıştır. Verilerin analizinde betimsel istatistiklerden, t-testinden ve tek yönlü varyans analizi (ANOVA) yöntemlerinden yararlanılmıştır. Veriler, SPSS 19.0 istatistik paket programı kullanılarak analiz edilmiştir.

Arařtırma sonularına gre, uygulama ncesinde deney ve kontrol gruplarındaki ğrencilerin matematik dersine karřı z-yeterlilik algıları ve geometri dersine ynelik z-yeterlilik inan puanları arasında anlamlı bir farklılık bulgulanmazken, yapılan uygulama sonrasında gruplardaki ğrencilerin matematik dersine karřı z-yeterlilik algıları ve geometri dersine ynelik z-yeterlilik inan puanları arasında deney grubu lehine istatistiksel olarak anlamlı bir farklılık tespit edilmiřtir.

Anahtar Kelimeler: Akıllı Tahta, Matematik Eđitimi, z-yeterlilik, Matematiđe Karřı z-yeterlilik Algısı, Geometriye Ynelik z-Yeterlilik.

Keywords: Smart Board, Mathematics Education, Self-efficacy, self-efficacy in mathematics Perception, Self-Efficacy !Toward! Geometry.

GELECEĞİN SINIF ÖĞRETMENLERİ VE FENİN GÜNLÜK HAYATLARINDAKİ YERİ

PRIMARY TEACHER OF THE FUTURE AND THE LOCATION OF SCIENCE IN THEIR DAILY LIVES

Yasemin BÜYÜKŞAHİN
Bartın Üniversitesi
ybuyuksahin@bartin.edu.tr

Pınar ÖZDEMİR ŞİMŞEK
Hacettepe Üniversitesi
pozdemir@hacettepe.edu.tr

ÖZET: Ülkemiz fen bilimleri ders kapsamında sorgulayan, araştıran, bilimi hayatını kolaylaştırmada kullanabilen bireyler yetiştirmek esastır. Bu nedenle araştırmada geleceğin bilim adamlarını yetiştirecek olan sınıf öğretmeni adaylarının günlük hayatlarında bilimsel bilgileri kullanma düzeyleri ve fenin günlük hayattaki yerine verdikleri önem hakkındaki görüşlerinin tespiti amaçlanmıştır. Araştırmada amaçlı örnekleme yöntemiyle tespit edilmiş Bartın Üniversitesi Eğitim Fakültesi İlköğretim Bölümü Sınıf Öğretmenliği 1. ve 2. sınıfta öğrenim görmekte olan 9 öğretmen adayı çalışma grubunu oluşturmaktadır. Araştırmada nitel yöntem kullanılmış, çalışma ‘durum çalışması deseni’ ile yürütülmüştür. Veriler, formu araştırmacılar tarafından geliştirilen yarı-yapılandırılmış görüşmeler kullanılarak elde edilmiştir. Toplanan veriler içerik analizi yöntemiyle analiz edilmiştir. Görüşme analizlerine göre sınıf öğretmeni adaylarının fen okuryazarlığına dair bilgi sahibi olmalarına ve fen eğitiminde model olma için fenin günlük hayatla ilişkilendirilmesi gerektiğine inanmalarına rağmen bilinçli olarak feni günlük hayatlarında kullanmadıkları tespit edilmiştir. Sınıf öğretmeni yetiştirme programının fen okuryazarlığını geliştirmede yeterli olmadığı sonucuna varılmıştır. Öğretim programının geliştirilmesi ve uygulama derslerinin artırılması gibi önerilerde bulunulmuştur.

Anahtar sözcükler: Sınıf öğretmeni adayları, Günlük hayat, Fen bilimleri

ABSTRACT: It is essential to educate individuals who can use science in daily life, investigate and research in our country's science course. Therefore, the research is intended to identify the pre-service primary teachers' who will train scientists of future, the level of scientific knowledge use in their daily lives and the importance they attach science in daily life. The sample group, which is selected through the purposive sampling method, included nine teacher candidates enrolled in Primary Teacher Program of Faculty of Education in Bartın University. In the study was used qualitative methods and carried out 'case study design'. The data, form developed by researchers was obtained using half-structured interview. The collected data were analyzed by the content analysis method. According to the analysis of interview pre-service teachers have knowledge about science literacy and believe it should be associated with daily life for being a model for science education despite it is identified they don't use the science consciously use in everyday life. Teacher training program is not sufficient in improving science literacy has been concluded. Suggestions have been made, such as development of the curriculum and increase implementation lessons.

Key words: Pre-service primary teacher, Daily life, Science

MATEMATİK ETKİNLİKLERİ OLUŞTURMAK İÇİN ÖĞRENME YÖNETİM SİSTEMİ KULLANIMINA YÖNELİK ÖNERİLER

Celal Murat KANDEMİR

Günümüzde geleneksel öğrenme ortamlarında yüz yüze eğitim, bilgi ve iletişim teknolojileri ile desteklenmekte ya da bilgi iletişim teknolojilerine dayalı eğitimle yavaş yavaş yer değiştirmektedir. Hem öğrenciler hem de öğretmenlerin öğrenme nesnelерinin sağlanması ve kullanılmasında yeni yöntemleri kullanabilme yeteneklerinin olması bu yüzden önemlidir. Bilgi ve iletişim teknolojilerine dayalı eğitimde yaygın olarak kullanılan öğrenme yönetim sistemleri ders ve etkinliklerin oluşturulduğu, ders materyallerinin paylaşıldığı, sınav notları ve diğer değerlendirilebilir etkinliklerin öğrencilere atanabildiği bir web tabanlı uygulama olarak tanımlanabilir. Ayrıca öğrencilerin forum ya da wiki aracılığıyla çevrimiçi işbirliği yapabildikleri bir ortamdır. Öğrenme yönetim sistemleri, hazırlanan ders materyallerinin öğrencilere iletilmesi, ödevlerin çevrimiçi olarak toplanması ve çoktan seçmeli sorular üzerinden değerlendirme etkinliklerinin yapılması amacıyla yaygın olarak kullanılmaktadır. Bununla birlikte görseller ile zenginleştirilmiş bir şekilde tasarlandığında öğrenme yönetim sisteminde bulunan değerlendirilebilir etkinlikler tek başlarına bir e-öğrenme içeriği olarak da kullanılabilir. Bu çalışmada, birinci sınıf matematik dersi öğretim programının sayısal öğrenme alanında önerilen etkinliklerin bir öğrenme yönetim sistemi üzerinde etkileşimli olarak nasıl gerçekleştirilebileceğine yönelik öneriler sunulmuştur. Bu amaçla farklı öğrenme yönetim sistemlerinde bulunan etkinlik araçlarının ne şekilde kullanılacağı incelenmiştir. Etkinliklerin oluşturulmasında kullanılacak olan resimlerin nasıl elde edilebileceğine ve telif hakları ile ilgili bilgilerin kontrolleri yapılırken dikkat edilmesi gerekli durumlar hakkında bilgi verilmiştir. Matematik dersi öğretim programı birinci sınıf sayısal öğrenme alanında bulunan toplam 27 etkinlik içinden seçilen etkinlikler öğrenme yönetim sistemi üzerinde değerlendirilebilir etkinlikler olarak tasarlanmıştır.

Anahtar Kelimeler: Öğrenme Yönetim Sistemleri, Matematik Eğitimi, E-Öğrenme

oooooooooooooooo

MATEMATİK ETKİNLİKLERİ OLUŞTURMAK İÇİN ÖĞRENME YÖNETİM SİSTEMİ KULLANIMINA YÖNELİK ÖNERİLER

Celal Murat KANDEMİR

Günümüzde geleneksel öğrenme ortamlarında yüz yüze eğitim, bilgi ve iletişim teknolojileri ile desteklenmekte ya da bilgi iletişim teknolojilerine dayalı eğitimle yavaş yavaş yer değiştirmektedir. Hem öğrenciler hem de öğretmenlerin öğrenme nesnelерinin sağlanması ve kullanılmasında yeni yöntemleri kullanabilme yeteneklerinin olması bu yüzden önemlidir. Bilgi ve iletişim teknolojilerine dayalı eğitimde yaygın olarak kullanılan öğrenme yönetim sistemleri ders ve etkinliklerin oluşturulduğu, ders materyallerinin paylaşıldığı, sınav notları ve diğer değerlendirilebilir etkinliklerin öğrencilere atanabildiği bir web tabanlı uygulama olarak tanımlanabilir. Ayrıca öğrencilerin forum ya da wiki aracılığıyla çevrimiçi işbirliği yapabildikleri bir ortamdır. Öğrenme yönetim sistemleri, hazırlanan ders materyallerinin öğrencilere iletilmesi, ödevlerin çevrimiçi olarak toplanması ve çoktan seçmeli sorular üzerinden değerlendirme etkinliklerinin yapılması amacıyla yaygın olarak kullanılmaktadır. Bununla birlikte görseller ile zenginleştirilmiş bir şekilde tasarlandığında öğrenme yönetim sisteminde bulunan değerlendirilebilir etkinlikler tek başlarına bir e-öğrenme içeriği olarak da kullanılabilir. Bu çalışmada, birinci sınıf matematik dersi öğretim programının sayısal öğrenme alanında önerilen etkinliklerin bir öğrenme yönetim sistemi üzerinde etkileşimli olarak nasıl gerçekleştirilebileceğine yönelik öneriler sunulmuştur. Bu amaçla farklı öğrenme yönetim sistemlerinde bulunan etkinlik araçlarının ne şekilde kullanılacağı incelenmiştir. Etkinliklerin oluşturulmasında kullanılacak olan resimlerin nasıl elde edilebileceğine ve telif hakları ile ilgili bilgilerin kontrolleri yapılırken dikkat edilmesi gerekli durumlar hakkında bilgi verilmiştir. Matematik dersi öğretim programı birinci sınıf sayısal öğrenme alanında bulunan toplam 27 etkinlik içinden seçilen etkinlikler öğrenme yönetim sistemi üzerinde değerlendirilebilir etkinlikler olarak tasarlanmıştır.

Keywords: Learning Management Systems, Mathematics Education, E-Learning

ÖĞRETMEN ADAYLARININ SABİT FONKSİYONLARIN PERİYODU İLE İLGİLİ KAVRAM İMAJLARI

PRESERVICE TEACHERS' CONCEPT IMAGES RELATED TO THE PERIOD OF CONSTANT FUNCTIONS'

Abdulkadir ÖNER
Necmettin Erbakan University
aoner@konya.edu.tr

Erhan ERTEKİN
Necmettin Erbakan University
eertekin@konya.edu.tr

Bu çalışmanın amacı, ilköğretim matematik öğretmen adaylarının sabit fonksiyonların periyoduyla ilgili kavram imajlarını belirlemektir. Çalışma, 2011-2012 eğitim-öğretim yılında bir devlet üniversitesinin İlköğretim Matematik Öğretmenliği programının 1.sınıfına kayıtlı 58 öğretmen adayı ile gerçekleştirilmiştir. Öğretmen adaylarının kavram imajları periyot özelinde detaylı incelendiğinden araştırmanın deseni nitel araştırma yöntemlerinden örnek olay çalışmasıdır. Araştırmanın amacına uygun olarak öğretmen adaylarına grafik temsili verilen sabit bir fonksiyonun periyodik olup olmadığı sorulmuştur. Gerek bu soruya verilen cevaplar gerekse maksimum çeşitlilik örnekleme ile belirlenen katılımcılarla yapılan yarı yapılandırılmış görüşmelerden elde edilen veriler içerik analizine tabi tutulmuş ve öğretmen adaylarının sabit fonksiyonların periyoduyla ilgili imajları Tall ve Vinner'in (1981) kavram imajı-kavram tanımı teorisi çerçevesinde belirlenmiştir. Shama'ya (1998) göre sabit fonksiyon periyodik değildir. Dormolen ve Zaslavsky'ye (2003) göre sabit bir fonksiyonun değerlerinin değişmemesi ve periyodunun olmaması nedeniyle buna dayanak gösterilebilir. Bu yaklaşım kabul edildiğinde, araştırmaya katılan öğretmen adaylarının %36'sı fonksiyonun periyodik olduğunu belirtip soruyu yanlış cevaplamış, %55'i ise doğru cevaba ulaşmıştır. Öğretmen adaylarından cevabını açıklayanların %55'i fonksiyonun "sabit" olduğu ve %10'u "belirli bir aralığa sahip olmadığı" için periyodik olmadığını belirtmiştir. Öte yandan, %18'i "düzenli tekrarlara sahip olduğu" ve %15'i "sabit" olduğu için periyodik olduğunu belirtmiştir. Fonksiyonun sabit olmasının hem periyodik olmasına hem de olmamasına gerekçe olarak gösterilmesi, Dormolen ve Zaslavsky'nin (2003) sabit fonksiyon tanımının matematikte bir dejenerasyon olduğu düşüncesini desteklemektedir. Matematiksel tanımların uygun olmayan örneklere neden olmayacak şekilde kapsayıcı nitelikte olması gerektiği; aksi takdirde yanlış imajlara neden olabileceği çıkarımında bulunabilir.

Anahtar sözcükler: Kavram İmajı, Kavram Tanımı, Periyot, Sabit Fonksiyon.

ABSTRACT: This study has been conducted to investigate preservice elementary mathematics teachers' concept images related to the period of constant functions'. The sample consists of 58 freshmen preservice elementary mathematics teachers who were registered to a Turkish state university in 2011-2012 academic year. This qualitative study's design is case study. A constant function has been asked whether it is periodic or not by giving its graph. After collecting data by this question and semi-structured interviews done with some selected participants, content analysis was examined to investigate period images in the spotlight of Tall and Vinner's (1981) concept image-concept definition theory. According to Shama's (1998) approach that constant function is not periodic, 36% of participants misanswered while 55% of them answered correct. Constancy of function has been a reason for periodicity (with 55%) and also for nonperiodicity (with 15%) of it, which supports for Dormolen and Zaslavsky's (2003) assertion that a constant function is a degeneration of the period concept. Finally, mathematical definitions have to be done "well" in order not to cause counter-examples and unsuitable concept images.

Key words: Concept Definition, Concept Image, Constant Function.

KHALIFA UNIVERSITY OF SCIENCE, TECHNOLOGY AND RESEARCH (KUSTAR) STUDENTS' ATTITUDES TOWARDS MATHEMATICS IN THE LIGHT OF VARIABLES SUCH AS GENDER, NATIONALITY, MATHEMATICS SCORES AND THE COURSE THEY ARE ATTENDING

Yousef ABOSALEM
Khalifa University
Yousef.abosalem@kustar.ac.ae

ABSTRACT: This study was aimed at identifying the attitudes of the students of Khalifa University towards mathematics. The sample of this study consisted of 88(out of 216) students distributed evenly according to gender. 56.9% of the sample were Emiratis and 53.1% were expatriates. The Attitude Towards Mathematics Inventory (ATMI) was implemented in collecting the data.

The results of this study indicated that there were slight statistically significant differences between students' attitudes towards mathematics and mathematics achievement scores, age, the course they are attending, students' high school type, gender and their academic level. Additionally, the results indicated that there were statistically significant differences between self-confidence, enjoyment and value with and students' nationalities. Expatriates students showed higher positive attitudes towards mathematics than the Emirati students. Also, the results showed that there was a slight statistical relationship between enjoyment and students' academic level.

Finally, this study revealed that 62.67% of the sample have self-confidence in dealing with mathematics, 84.4% felt that mathematics has a great value to them, and 75.49% showed enjoyment in dealing with mathematics.

Keywords: Attitudes, mathematics, gender, nationality, course attending

INTRODUCTION

Researches on students' attitudes toward mathematics have acquired increasing attention. Many studies outlined that mathematics learning is influenced by several factors; such as motivation, curriculum, teacher and his way of teaching and educational teaching aids he used (Cote & Levine, 2000; Singh et al., 2002; Olatunde, 2009; Howie, 2005; Singh, et al., 2002). Hill (2004) indicated that integrating mathematics and science curriculum does improve students' attitude toward mathematics. Yet, regardless of the amount of effort spend in the improvement and development of mathematics learning process, efforts will have a slight impact in achievement unless there is a positive attitude towards mathematics. (Ma & Kishor, 1997; Ma, & Xu, 2004). However, many factors have influences on students' attitudes toward mathematics. Teachers, parents, and peers, as well as the school environment, all have influences on an individual's attitude. Wilkins and MA (2003) showed that teachers', peers', and parents' positive support will help in creating positive attitude and beliefs about mathematics and thus help restrain negative attitudes and beliefs. Whereas Ames (1992) considered student's home environment and access to instructional materials can all have an impact on his attitude and achievement.

Purpose of the Study

The general purpose of this study was to find out the attitudes of the students of Khalifa University of Science Research and Technology (KUSTAR) towards mathematics. The study is focused on the relationship of their attitudes towards mathematics with other factors such as; gender, mathematics scores, high school type, nationality, academic level, age and the mathematics course they are attending.

Research Questions

This study aimed to answer the following questions:

1. What is the prelateship between students' attitudes towards mathematics and academic achievement?
2. What is the relationship between students' attitudes towards mathematics and gender?
3. What is the relationship between students' attitudes towards mathematics and nationalities?
4. What is the relationship between attitudes towards mathematics and academic level (foundation or freshmen year)?
5. What is the relationship between attitudes towards mathematics and age?

6. What is the relationship between attitudes towards mathematics and mathematics courses they are attending?
7. What is the relationship between attitudes towards mathematics and high school type?

Definition of Terms

The following definitions are provided for terms having special applications to this study.

1. Attitude – “refers to someone’s basic liking or disliking of familiar target” (Hannula, 2002; p.25)
2. High School Type: The high school type refers to either private or government school.
3. Academic Level: The academic level refers to whether the student is in foundation or freshman year.
4. Nationality: The nationality refers to whether the student is an Emirati or an Expatriate.

Literature review

Many studies have studied the students’ attitudes towards mathematics and the impact of that on their achievement. Gottfried (1985) reported in his study that students who value and enjoy mathematics have a higher level of achievement. As well as, Ma and Xu (2004) showed in their study that poor achievement has been linked to a decline in mathematics attitude. Therefore, achievement in mathematics caused a positive attitude. However, a positive attitude towards mathematics does not lead to a good achievement. Other factors might affect students’ achievement in mathematics such as textbooks, and teacher quality (Howie, 2005). Yet, both Tapia and Marsh II (2004) argue that students who do well in mathematics showed positive attitudes, consequently they are likely to take more mathematics courses. So, attitude and achievement affect each other in a cyclical manner (Schiefele & Csikszentmihalyi, 2004). Whereas, Ma and Kishor (1997) concluded that the relationship between attitudes towards mathematics and mathematics achievement is not a strong enough. Therefore, Phonguttha, et al. (2009) agreed with Ma and Kishor that mathematics achievement and attitude towards mathematics are not correlated. Furthermore, Casey et al. (1997) and Ma (1999) showed that the relationship between attitude and mathematics achievement exists only with respect to specific or particular mathematics content areas. Maple and Stage (1991) indicated that students’ attitude towards mathematics could be used as a predictor of selecting a mathematics major but not for achievement. Along with that, Oakes (1990) argued that students with lower levels of achievement in mathematics confine students’ career alternatives involving mathematical skills.

We do know that students’ attitudes towards mathematics change overtime because it could be replaced by other activities. Students in the early stages of schooling are given the mathematical concepts slowly and repeatedly by using different teaching aids, resulting in positive attitudes and high achievement for the majority of students. As the mathematical subjects gets more abstract and more diverse, students’ attitudes and achievement started to decline or decrease (Ma & Kishor, 1997; Hannula, 2002; Sanchez et al., 2004). The decline in students’ attitude towards mathematics could be justified by the huge number of alternatives available for today’s students.

Other studies outlined that students’ achievement in mathematics is influenced by a variety of factors other than students’ attitudes towards mathematics, such as gender, teacher’s experience, parents, socioeconomic status, ethnicity, cultural background, grade level and peers (Casey et al, 1997; Ho, et al., 2000; Ma & Kishor, 1997; Ma, 1999, 1997; Carrier, 2008; Isiksal, 2008). Moreover, other researchers outlined that students’ attitudes towards mathematics can be affected by teacher attitudes and beliefs (Uusimaki & Nason, 2004; Beswick, 2006; Wilkins & Brand, 2004; Swan, Bell, et al., 2000; Schoenfeld, 1985; Beswick, 2007). Along with that, teaching techniques were considered by many researchers as other factors that could affect students’ attitudes toward mathematics (Anderson, 2005; Townsend et. al., 1998; Higgins, 1997; Pearce et. al., 1999; Mitchell, 1999; Kinney, 2001; Yusof & Tall, 1998; Elliott et. al., 2001; Raymond & Leinenbach, 2000; Whitin, 2007).

Furthermore, Tymms (2001) stated that the most important factors affecting students’ attitudes towards mathematics were the teacher and student academic level; while gender, age and language were weakly related with students’ attitudes. Koller, et al. (2001) researched gender differences in mathematics achievement, which showed that male achievement is higher than that of female one especially in advanced mathematics courses. However, other researchers (Tapia & Molavan (2007; Tapia & Marsh II, 2004; Isiksal & Cakiroglo, 2008) showed that gender had no effect on students’ attitudes towards mathematics and male and female students had the same average mathematics score. Vaughan (2002) introduces another factor that has a direct impact on students’ attitudes towards mathematics. He argues that using cooperative learning in our schools will increase the interaction between students and consequently produce positive attitudes towards mathematics and academic achievement.

METHODS

This study was aimed at identifying the attitudes of the students of Khalifa University of Science, Technology and Research (KUSTAR) towards mathematics in the light of variables such as gender, nationality, mathematics scores and the course they are attending

Data Collection Instrument

In this study the Attitudes Towards Mathematics Inventory (ATMI) (Appendix A) was used to collect data about students' attitudes towards mathematics. ATMI consists of 40-items, 5-points Likert scale ranging from strongly disagree to strongly agree distributed by using exploratory factor analysis into four areas or domains related to attitudes towards mathematics including self-confidence (15 items), value(10 items), enjoyment(10 items), and motivation(5 items) as shown in table-1. The instrument has a reliability coefficient alpha of 0.97 with standard error of measurement of 5.67 (Tapia, 1996). It also demonstrates content and constructs validities.

Table 1. The distribution of the ATMI scale according to the four domains

Domain	Items	Total
Self-confidence	9,10,11,12,13,14,15,16,17,18,19,20,21,22,40	15
Value	1,2,4,5,6,7,8,35,36,39	10
Enjoyment	3,24,25,26,27,29,30,31,37,38	10
Motivation	23,28,32,33,34	5
Total		40

Sample

The sample of this study consisted of 88 out of 216 undergraduate students at Khalifa University randomly selected from all students enrolled in the pre-calculus, calculus-I, and calculus-II courses whose ages ranged from 18 to 22 years old and agreed to participate in this research. As shown in table 2, forty-four students of the sample were male and the same number was female. 58(66%) students were Emiratis and 30 (34%) students were expatriates.

Table 2. The sample distribution according to gender, age, and nationality

Gender	Nationality	Age(years)					Total
		18	19	20	21	22	
Male	UAE	1	19	12	1	0	33
	Others	3	6	1	0	1	11
	Total	4	25	13	1	1	44
Female	UAE	4	14	7	0		25
	Others	2	11	4	2		19
	Total	6	25	11	2		44
Total		10	50	24	4		88

Table 3 and figure 1 show the sample distribution according to the mathematics courses they are attending and the type of the school they obtained their high school diploma from. 67 of them obtained their high school diploma from government school and 21 were from private ones. Whereas, 24 students are in Pre-calculus, 27 students are in Calculus I and 37 students are in Calculus II.

Table 3. The sample distribution according to High school type, and Course are attending

High School Type	Course			Total
	Pre-Calculus	Calculus-I	Calculus-II	
Government	19	18	30	67
Private	5	9	7	21
Total	24	27	37	88

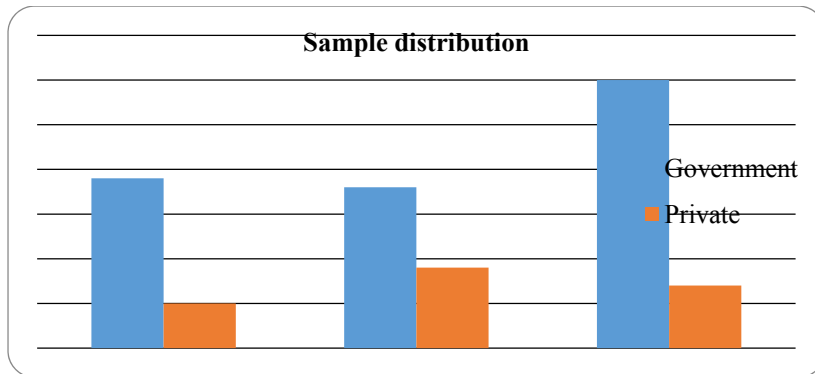

Figure 1. The sample distribution according to high school type and Course are attending

RESULTS AND FINDINGS

Research Question 1

What is the relationship between students' attitude towards mathematics and academic achievement?

In order to answer the first research question, and by assuming that the data is normally distributed according to Kolmogorov and Shapiro tests with $p > 0.05$, Pearson correlations were calculated. The results shown in table 4 outlined that there is a slight significant relationship between students' attitudes towards mathematics and mathematics achievement scores. However, this relation can explain 9.24% of the variance, 90.76 % unjustified or unexplained.

Table 4. Pearson correlations between students' attitudes and academic achievement

		Attitude	Math Grade
Attitude	Pearson Correlation	1	0.304*
	Sig. (2-tailed)		0.017
	N	76	61
Math Grade	Pearson Correlation	.304*	1
	Sig. (2-tailed)	0.017	
	N	61	69

*. Correlation is significant at the 0.05 level (2-tailed).

Research Question 2

What is the relationship between students' attitude towards mathematics and gender?

In order to find out if there is statistically significant differences between students' attitudes towards mathematics and gender. By assuming the homogeneity of the two variances according to Levene's test with $p > 0.05$ as shown in table 5, and according to Kolmogorov-Smirnov and Shapiro-Wilk normality tests, we can assume that the data achieved the normality condition with $p > 0.05$ as shown in table 6. As shown in table 7 the means and standard deviations for the two groups are: 140.67, 140.70, 9.78, and 9.16 respectively. Four separate analyses of variances (ANOVA) were conducted as shown in table 8. The results indicated that no statistically significant differences between the four domains and gender with $p > 0.05$.

Table 5. The levene's test of variances homogeneity

Levene's Test for Equality of Variances			
		F	Sig.
Attitude	Equal variances assumed	0.032	0.859

Table 6. The normality test

Attitude	Kolmogorov-Smirnov			Shapiro-Wilk		
	Statistic	df	Sig.	Statistic	df	Sig.
	0.086	76	.200*	0.971	76	0.076

Table 7. The descriptive statistics according to the gender

	Gender	N	Mean	Std. Deviation	Std. Error Mean
Attitude	Male	39	140.67	9.78	1.56563
	Female	37	140.7	9.16	1.50667

Table 8. The four analysis of variances(ANOVA) according to the gender

Domain		Sum of Squares	df	Mean Square	F	Sig.
Self_ Confidence	Between Groups	20.555	1	20.555	.867	.355
	Within Groups	1848.195	78	23.695		
	Total	1868.750	79			
Value	Between Groups	.705	1	.705	.030	.862
	Within Groups	1933.601	83	23.296		
	Total	1934.306	84			
Enjoyment	Between Groups	2.012	1	2.012	.076	.784
	Within Groups	2174.690	82	26.521		
	Total	2176.702	83			
Motivation	Between Groups	.440	1	.440	.079	.779
	Within Groups	460.383	83	5.547		
	Total	460.824	84			

Research Question 3**What is the relationship between students' attitudes towards mathematics and nationalities?**

In order to find out if there is a statistically significant difference between students' attitudes toward mathematics and nationalities, the homogeneity of the two variances was assumed according to Levene's test with $p > 0.05$ as shown in table 9 and descriptive statistics shown in table-10. As shown previously in table-6, it can be assumed that the data is normally distributed. Four separate analyses of variances (ANOVA) were conducted as shown in table 11. The results indicated that there were statistically significant differences between self-confidence $F(1, 78) = 9.699$ and $p = 0.03$, enjoyment $F(1, 82) = 15.285$ and $p = 0.001$, and value $F(1, 83) = 6.419$ and $p = 0.013$, and students' nationalities at $\alpha = 0.05$. However, the results showed that there is no statistically significant difference between motivation $F(1,83) = 1.148$ and $p = 0.228$, and nationality at $\alpha = 0.05$. No Post Hoc comparisons were conducted because the number of values in each domain is less than three values. However, according to the descriptive statistics mentioned in table 10, we can conclude that the other nationalities with a mean value of 142.79 have higher positive attitudes towards mathematics than UAE students with a mean of 139.46.

Table 9. The levene's test of variances homogeneity

Levene's Test for Equality of Variances	
	Sig.
F	

Attitude	Equal variances assumed	0.393	0.532
----------	-------------------------	-------	-------

Table 10. The descriptive statistics according to the nationalities

Nationality	N	Min.	Max.	Mean	Std. Deviation	
UAE	Attitude	48				
	Valid N (leastwise)	48	108	160	139.4583	9.25745
Others	Attitude	28	117	158	142.7857	9.49213
	Valid N (leastwise)	28				

Table 11. The Four Analyses Of Variances (ANOVA) According To The Nationalities

Domain	Sum of Squares	df	Mean Square	F	Sig.	
Self_Confidence	Between Groups	206.67	1	206.67	9.699	
	Within Groups	1662.08	78	21.309		
	Total	1868.75	79			0.003
Value	Between Groups	138.85	1	138.85	6.419	
	Within Groups	1795.456	83	21.632		
	Total	1934.306	84			0.013
Enjoyment	Between Groups	342.002	1	342.002	15.285	
	Within Groups	1834.7	82	22.374		
	Total	2176.702	83			0
Motivation	Between Groups	8.063	1	8.063	1.478	
	Within Groups	452.76	83	5.455		
	Total	460.824	84			0.228

Research Question 4

What is the relationship between attitudes towards mathematics and academic level (foundation or freshmen year)?

In order to find out if there is statistically significant differences between students' attitudes towards mathematics and their academic level. The homogeneity of the two variances and the data that was normally distributed were assumed according to Levene's test with $p > 0.05$ as shown in table 12. Based on the descriptive statistics shown in table 13 and according to Kolmogorov-Smirnov and Shapiro-Wilk normality tests, four separate analyses of variances (ANOVA) were conducted as shown in table 14. The results indicated that there were no statistically significant differences between students' attitudes towards mathematics and students' academic year at $\alpha = 0.05$. However, the analysis showed that there is a slight statistically significant difference between enjoyment and student's academic level $F(1, 82) = 4.198$ with $p = 0.044$ favor to freshman students ($\bar{x} = 140.88$).

Table 12. The Levene's Test Of Variances Homogeneity

Levene's Test for Equality of Variances			
		F	Sig.
Attitude	Equal variances assumed	1.038	0.312

Table 13. The Descriptive Statistics According To Attitude And Academic Level

	Academic Level	N	Mean	Std. Deviation	Std. Error Mean
Attitude	Foundation	18	140.0556	7.97402	1.87949
	Freshman	58	140.8793	9.88189	1.29756

Table 14. The Four Analysis Of Variances(ANOVA) According To The Academic Level And Attitude

	Domain	Sum of Squares	df	Mean Square	F	Sig.
Self_ Confidence	Between Groups	88.817	1	88.817	3.89	
	Within Groups	1779.933	78	22.82	2	0.052
	Total	1868.75	79			
Value	Between Groups	9.287	1	9.287	0.4	
	Within Groups	1925.019	83	23.193		0.529
	Total	1934.306	84			
Enjoyment	Between Groups	106.002	1	106.002	4.198	
	Within Groups	2070.7	82	25.252		0.044
	Total	2176.702	83			
Motivation	Between Groups	1.32	1	1.32	0.238	
	Within Groups	459.504	83	5.536		0.627

Research Question 5

What is the relationship between students' attitudes towards mathematics and age?

In order to answer the fifth research question, and by assuming that the data is normally distributed according to Kolomogrov and Shapirotests with $p > 0.05$, Pearson correlations were calculated. The results as shown in table 15 outlined that there is no meaningful relationship between students' attitudes towards mathematics and age at $\alpha = 0.05$. However, only this relationship can explain 4.7% of the variance, 95.3 % unjustified or unexplained.

Table 15. The Correlations Between Students' Attitude Towards Mathematics And Age

		Attitude	Age
Attitude	Pearson Correlation	1	-0.217
	Sig. (2-tailed)		0.06
	N	76	76
Age	Pearson Correlation	-0.217	1
	Sig. (2-tailed)	0.06	
	N	76	88

Research Question 6

What is the relationship between attitudes towards mathematics and mathematics course they are attending?

In order to find out if there is a statistically significant difference between students' attitudes towards mathematics and the course they are attending. The homogeneity of the variances according to Levene's test with $p > 0.05$ as shown in table 16, the data is normally distributed according to Kolomogrov and Shapiro tests with $p > 0.05$ were assumed. Four separate analyses of variances (ANOVA) were conducted as shown in table 18. The results indicated that there were no statistically significant difference between students' attitudes towards mathematics and the course they are attending at $\alpha = 0.05$.

Table 16. The Levene's Test Of Variances Homogeneity

Levene's Test for Equality of Variances			
		F	Sig.
Attitude	Equal variances assumed	0.001	0.979

Table 17. The Four Analyses Of Variances (ANOVA) According To The Math. Courses They Are Attending

Domain		Sum of Squares	df	Mean Square	F	Sig.
Self-Confidence	Between Groups	101.007	2	50.504	2.2	0.118
	Within Groups	1767.743	77	22.958		
	Total	1868.75	79			
Value	Between Groups	69.607	2	34.803	1.53	0.223
	Within Groups	1864.699	82	22.74		
	Total	1934.306	84			
Enjoyment	Between Groups	140.077	2	70.038	2.786	0.068
	Within Groups	2036.626	81	25.144		
	Total	2176.702	83			
Motivation	Between Groups	7.588	2	3.794	0.686	0.506
	Within Groups	453.236	82	5.527		
	Total	460.824	84			

Research Question 7

What is the relationship between attitude towards mathematics and high school type?

In order to find out if there is a statistically significant difference between students' attitudes towards mathematics and high school type. By assuming that the homogeneity of the two variances according to Levene's test as shown in table 18, and the data is normally distributed according to Kolomogrov and Shapiro tests with $p > 0.05$. Four separate analyses of variances (ANOVA) were conducted as shown in table 19 .The results indicated that there were no statistically significant differences between students' attitudes and students' high school type.

Table 18. The Levene's Test Of Variances Homogeneity

Levene's Test for Equality of Variances			
		F	Sig.
Attitude	Equal variances assumed	0.001	0.979

Table 19. The Four Analyses Of Variances (ANOVA) According To The High School Type

Domain	Sum of Squares	df	Mean Square	F	Sig.
--------	----------------	----	-------------	---	------

Self_ Confidence	Between Groups	28.017	1	28.017		
	Within Groups	1840.733	78	23.599	1.187	.279
	Total	1868.750	79			
Value	Between Groups	.090	1	.090		
	Within Groups	1934.215	83	23.304	.004	.950
	Total	1934.306	84			
Enjoyment	Between Groups	32.861	1	32.861		
	Within Groups	2143.841	82	26.144	1.257	.266
	Total	2176.702	83			
Motivation	Between Groups	1.239	1	1.239	.224	.637

DATA ANALYSIS OF THE FOUR DOMAINS

Self-Confidence Domain

Table 20 showed that 62.67% of the sample reveals that KUSTAR students felt self-confidence in their ability to do mathematics, whereas, 13.67% of them showed low self-confidence in their ability to do mathematics.

Table 20. The Percentages And Frequencies Of Students' Responses On The Self-Confidence Domain

Item	Strongly Disagree	Disagree	Neutral	Agree	Strongly Agree
Item 9*	11	15	20	20	16
Item 10*	3	7	17	33	28
Item 11*	3	6	19	40	20
Item 12*	3	5	17	38	25
Item 13*	3	10	19	31	22
Item 14*	1	10	12	37	27
Item 15*	1	15	13	35	23
Item 16	1	14	18	32	21
Item	4	6	26	31	19

17					
Item 18	2	13	31	33	8
Item 19	2	6	20	39	20
Item 20*	6	6	22	38	15
Item 21*	2	13	23	33	17
Item 22	1	5	27	39	16
Item 40	0	4	24	39	21
Total	43	135	308	518	298
Percent	3.30%	10.37%	23.66%	39.78%	22.89%

Value Domain

Table 21 showed that 84.40% of the sample reveals that KUSTAR student felt that mathematics has a great value to them. Whereas, 4.29% of them indicated that mathematics has no value for them.

Table 21. The percentages and frequencies of students' responses on the Value domain

Item	Strongly Disagree	Disagree	Neutral	Agree	Strongly Agree
Item 1	4	1	1	17	63
Item 2	3	0	3	9	70
Item 3	0	3	17	35	30
Item 4	1	1	5	30	49
Item 5	1	1	16	38	32
Item 6	0	2	7	36	43
Item 7	0	6	7	38	37
Item 8	2	8	30	35	12
Item 35	0	4	9	46	28
Item 36	0	2	6	41	38
Item 39	0	2	7	37	42
Total	11	30	108	362	444
Percent	1.15%	3.14%	11.31%	37.91%	46.49%

* Indicated Reversed Items

Motivation Domain

Table 22 showed that 67.13% of the sample reveals that KUSTAR students are highly motivated to learn mathematics, whereas, 10.35% of them lack motivation.

Table 22. The percentages and frequencies of students' responses on the Motivation domain

Item	Strongly Disagree	Disagree	Neutral	Agree	Strongly Agree
Item 23	0	6	15	45	22
Item 28*	3	7	7	38	33
Item 32	3	12	28	30	14
Item 33	1	7	24	37	18
Item 34	0	6	24	36	19
Total	7	38	98	186	106
Percent	1.61%	8.74%	22.53%	42.76%	24.37%

* Indicated Reversed Items

Enjoyment Domain

Table 23 showed that 75.49% of the sample reveals that KUSTAR students showed enjoyment in doing mathematics. Whereas, 7.90% of them indicated that mathematics is not an interesting subject.

Table 23. The percentages and frequencies of students' responses on the Enjoyment domain

Item	Strongly Disagree	Disagree	Neutral	Agree	Strongly Agree
Item 3	0	3	17	35	30
Item 24	3	5	10	38	32
Item 25*	4	5	5	38	36
Item 26	2	5	15	44	21
Item 27	8	4	10	20	46
Item 29	2	1	10	38	36
Item 30	2	11	21	36	17
Item 31	0	4	12	40	31
Item 37	2	3	25	41	17
Item 38	1	4	20	39	24
Total	24	45	145	369	290
Percent	2.75%	5.15%	16.61%	42.27%	33.22%

* Indicated Reversed Items

DISCUSSION AND CONCLUSIONS

A common understanding around the world that is students of different ages and of different studying levels are facing difficulties when they attempting to do mathematics. Many researches indicated that these difficulties might

due to mathematics teachers, curricula, assessment methods or/and teaching strategies used in schools and universities.

Many researches studied the effect of students' attitudes towards mathematics (see e.g. Tapia, 1996, 2004; Tapia & Molavan, 2007) on academic achievement. Some studies outlined that there is no impact of the students' attitudes towards mathematics on their academic achievement (see e.g. Ma and Kishor, 1997; Phonguttha, et al., 2009). Other studies showed that there is a relationship between attitudes towards mathematics and achievement (see e.g. Gottfried 1985; Ma and Xu, 2004; Popham, 2005; Koller, et al. (2001).

This study aimed at identifying the attitudes of Khalifa University of Science, Technology and Research (KUSTAR) students towards mathematics in the light of some variables such as gender, nationality, mathematics scores and the course they are attending. The results of this study showed that there were no statistically differences between students' attitudes towards mathematics according to gender, academic level, high school type and nationality. The results of this study agreed with other studies (see e.g. Casey et al, 2001; Ho, et al., 2000; Ma & Kishor, 1997; Ma, 1999, 1997; Tapia & Molavan, 2007; Tapia & Marsh II, 2004) in that there were no statistical differences between students' attitudes towards mathematics and other factors such as : gender, ethnicity, mathematics scores. In addition, this study outlined that 62.67% of KUSTAR students felt self-confidence in their ability to do mathematics, 84.40% of them felt that mathematics has a great value to them, 67.13% of them are highly motivated to learn mathematics, and 75.49% of the sample reveals that KUSTAR students showed enjoyment in doing mathematics.

Many factors have influences on students' attitudes towards mathematics. Teachers, parents, teaching strategies, assessment methods, and peers, as well as the school environment all have influences on an individual's attitude.

I do agree with Tymms (2001) in that the most important factors affecting students' attitudes towards mathematics were the teacher and student academic level, so that more studies have to be conducted in the future to clarify the relationship between teachers' and teaching characteristics on students' attitudes towards mathematics. As well as, to determine how teachers can modify or change their students' attitudes towards mathematics if that is possible, and what the effect of using collaborative learning in schools and universities on changing students' attitudes towards mathematics is. Personally, I think class size, teaching methods and assessment techniques used in our schools and universities might have an impact on the students' attitudes towards mathematics and consequently on their achievements.

REFERENCES

- Anderson, J. (2005). The relationship between student perceptions of team dynamics and simulation game outcomes: an individual-level analysis. *Journal of Education for Business* 81(2), 85-90.
- Beswick, K. (2007). Teachers' beliefs that matter in secondary mathematics classrooms. *Educational Studies in Mathematics*, 65(1), 95-120.
- Beswick, K. (2006). Changes in pre-service teachers' attitudes and beliefs: the net impact of two mathematics education units and intervening experiences. *School Science and Mathematics*, 106(1), 36-47.
- Carrier, S. J. (2007). Gender differences in attitudes toward environmental science. *School Science and Mathematics*, 107(7), 271-278.
- Casey, M.B., Nuttall, R.L., & Pezaris, E. (1997). Mediators of gender differences in mathematics college entrance test scores: A comparison of spatial skills with internalized beliefs and anxieties. *Developmental Psychology*, 33(4), 669-680.
- Cote, J.E. & Levine, C. G. (2002). Attitude versus aptitude: Is intelligence or motivation more important for positive higher-educational outcomes? *Journal of Adolescent Research*, 15(1), 58-80.
- Elliott, B., Oty, K., McArthur, J., & Clark, B. (2001). The effect of an interdisciplinary algebra/science course on students' problem solving skills, critical thinking skills and attitudes toward mathematics. *International Journal of Mathematical Education in Science & Technology*, 32(6), 811-816.
- Gottfried, A. E. (1985) Academic intrinsic motivation in elementary and junior high school students. *Journal of Educational Psychology*, 77(6), 631-645.
- Hannula, M. (2002). Attitude towards mathematics: Emotions, Expectations and values, *Educational studies in Mathematics*, 49(1), 25-46.

- Higgins, K. (1997). The effect of year-long instruction in mathematical problem solving on middle-school students' attitudes, beliefs, and abilities. *Journal of Experimental Education*, 66(1), 5-29.
- Hill, D. (2004). Student attitudes toward integrated mathematics. *Academic Exchange Quarterly*, 8(2), pp. 77-81.
- Ho, H., Senturk, D., Lam, A.G., Zimmer, J.M., Hong, S., Okamoto, Y., Chiu, S., Nakazawa, Y., and Wang, C. (2000). The affective and cognitive dimensions of math anxiety: A cross-national study. *Journal for Research in Mathematics Education*, 31(3), 362-379.
- Howie, S.J. (2005). Contextual factors at the school and classroom level related to pupils' performance in mathematics in South Africa. *Educational Research and Evaluation*, 11(2), 123-140.
- Isikal, M. and Cakiroglu, E. (2008). Gender differences regarding mathematics achievement: the case of Turkish middle school. *School Science and Mathematics*, 108(3), 113-120.
- Kinney, D. (2001). A comparison of computer-mediated and lecture classes in developmental mathematics. *Research and Teaching in Developmental Mathematics*, 18(1), 32-40.
- Koller, O., Baumert, J., and Schnable, K. (2001) Does interest matter? The relationship between academic interest and achievement in mathematics. *Journal for Research in Mathematics Education*, 32(5), 448-470.
- Maple, S. A., and Stage, F. K. (1991). Influences on the choice of math/science major by gender and ethnicity. *American Educational Research Journal*, 28(1), 37-60.
- Ma, X., and Kishor, N. (1997). Assessing the relationship between attitude toward mathematics and achievement in mathematics: A meta-analysis. *Journal for Research in Mathematics Education*, 28(1), 26-47.
- Ma, X. (1999). Dropping out of advanced mathematics: The effects of parental involvement. *Teachers College Record*, 101(1), 60-81.
- Ma, X., and Xu, J. (2004). Determining the causal ordering between attitude toward mathematics and achievement in mathematics. *American Journal of Education*, 110(3), 256-280.
- Mitchell, T. (1999). Changing student attitudes toward mathematics. *Primary Educator*, 5(4), 2-9.
- Oakes, J. (1990). Opportunities, achievement, and choice: Women and minority students in science and mathematics. *Review of Research in Education*, 16, 153-222.
- Olatunde, Y. P. (2009). Students attitude towards mathematics and academic achievement in some selected secondary schools in Southwest Nigeria. *European Journal of Scientific Research*, 36(3), 336-341.
- Pearce, K., Lungren, M., and Wince, A. (1999). The effects of curriculum practices on first graders' attitudes, activity preference, and achievements in mathematics. *Education*, 119(1), 82-90.
- Phonguttha, R., Tayraukham, S. and Nuangchalerm, P. (2009). Comparisons of Mathematics Achievement, Attitude towards Mathematics and Analytical Thinking between Using the Geometer's Sketchpad Program as Media and Conventional Learning Activities. *Australian Journal of Basic and Applied Sciences*, 3(3), 3036-3039.
- Popham, W. (2005). Students' attitudes count. *Educational Leadership*, 62(5), 84-85.
- Raymond, A., and Leinenbach, M. (2000). Collaborative action research on the learning and teaching of algebra: a story of one mathematics teacher's development. *Educational Studies in Mathematics*, 41(3), pp. 283-307.
- Sanchez, K., Zimmerman, L. and Ye, R. (2004) Secondary students' attitudes toward mathematics. *Academic Exchange Quarterly*- Summer, 56-60.
- Singh, K., Granville, M., and Dika, S. (2002) Mathematics and science achievement: Effects of motivation, interest, and academic engagement. *The Journal of Educational Research*, 95(6), 323-332.

- Swan, M., Bell, A., Phillips, R., and Shannon, A. (2000). The purpose of mathematical activities and pupils' perceptions of them. *Research in Education*, 63, 199-223.
- Tapia, M. and Marsh II, G. (2004). The relationship of math anxiety and gender. *Academic Exchange Quarterly – summer*, 130-134.
- Tapia, M. (1996). The Attitudes Toward Mathematics Instrument. *ERIC Document Reproduction Service No. ED404165*.
- Tapia, M. and Molavan, C. C. (2007). Attitudes toward mathematics of pre-calculus and calculus students, *Focus on Learning Problems in Mathematics*, 29(1), 48-59.
- Townsend, M., Moore, D., Tuck, B., and Wilton, K. (1998). Self-concept and anxiety in university students studying social science statistics within a cooperative learning structure. *Educational Psychology*, 18(1), 41-54.
- Tymms, P. (2001). A test of the big fish in a little pond hypothesis: An investigation into the feelings of seven-year-old pupils in schools. *School Effectiveness and School Improvement*, 12(2), pp. 161-181.
- Vaughan, W. (2002). Effects of cooperative learning on achievement and attitude among students of color. *The Journal of Educational Research*, 95(6), 359-364.
- Whitin, P. (2007). The mathematics survey: a tool for assessing attitudes and dispositions. *Teaching Children Mathematics*, 13(8), 426-432.
- Wilkins, J. and Ma, X. (2003). Modeling changes in student attitude toward and beliefs about mathematics. *The Journal of Educational Research*, 97(1), 52-63.
- Yusof, Y.M., and Tall, D. (1998). Changing attitudes to University mathematics through problem solving. *Educational Studies in Mathematics*, 37(1), 67-82.

Appendix - A

Dear Student:

This study aims at “Finding out Students Attitudes towards Mathematics at Khalifa University of Science Technology and Research (KUSTAR)”.

The information gathered by the questionnaire will be used for educational research only and is not related to your achievement or your performance in mathematics. All results will be kept strictly secret. Please read each statement carefully and write your answers in the space provided.

By filling this questionnaire, you agree to participate in this study

Thank you very much for your cooperation.

The researcher

Demographic Information

Gender	Male	Female	
Date of Birth			
Nationality			
High School Type	Government	Private	
High School Average		University GPA	
Academic Level	Foundation	Degree	
Course & Grade	Pre-Calculus()	Calculus I()	Calculus II()

Attitudes Toward Mathematics Inventory (ATMI)

Directions: This inventory consists of statements about your attitude toward mathematics. There are no correct or incorrect responses. Read each item carefully. Please think about how you feel about each item. Circle the letter that most closely corresponds to how the statements best describes your feelings. Use the following response scale to respond to each item.

PLEASE USE THESE RESPONSE CODES: A – Strongly Disagree
B – Disagree
C – Neutral
D – Agree
E – Strongly Agree

1. Mathematics is a very worthwhile and necessary subject.

A Strongly Disagree B Disagree C Neutral D Agree E Strongly Agree

2. I want to develop my mathematical skills.

A Strongly Disagree B Disagree C Neutral D Agree E Strongly Agree

3. I get a great deal of satisfaction out of solving a mathematics problem.

A Strongly Disagree B Disagree C Neutral D Agree E Strongly Agree

4. Mathematics helps develop the mind and teaches a person to think.

A Strongly Disagree B Disagree C Neutral D Agree E Strongly Agree

13. I am always under a terrible strain in a math class.

A Strongly Disagree B Disagree C Neutral D Agree E Strongly Agree

14. When I hear the word mathematics, I have a feeling of dislike.

A Strongly Disagree B Disagree C Neutral D Agree E Strongly Agree

15. It makes me nervous to even think about having to do a mathematics problem.

A Strongly Disagree B Disagree C Neutral D Agree E Strongly Agree

16. Mathematics does not scare me at all.

A Strongly Disagree B Disagree C Neutral D Agree E Strongly Agree

17. I have a lot of self-confidence when it comes to mathematics

A Strongly Disagree B Disagree C Neutral D Agree E Strongly Agree

18. I am able to solve mathematics problems without too much difficulty.

A Strongly Disagree B Disagree C Neutral D Agree E Strongly Agree

19. I expect to do fairly well in any math class I take.

A Strongly Disagree B Disagree C Neutral D Agree E Strongly Agree

20. I am always confused in my mathematics class.

A Strongly Disagree B Disagree C Neutral D Agree E Strongly Agree

5. Mathematics is important in everyday life.

A Strongly Disagree B Disagree C Neutral D Agree E Strongly Agree

6. Mathematics is one of the most important subjects for people to study.

A Strongly Disagree B Disagree C Neutral D Agree E Strongly Agree

7. High school math courses would be very helpful no matter what I decide to stu

A Strongly Disagree B Disagree C Neutral D Agree E Strongly Agree

8. I can think of many ways that I use math outside of school.

A Strongly Disagree B Disagree C Neutral D Agree E Strongly Agree

9. Mathematics is one of my most dreaded subjects.

A Strongly Disagree B Disagree C Neutral D Agree E Strongly Agree

10. My mind goes blank and I am unable to think clearly when working with mathematics.

A Strongly Disagree B Disagree C Neutral D Agree E Strongly Agree

11. Studying mathematics makes me feel nervous.

A Strongly Disagree B Disagree C Neutral D Agree E Strongly Agree

12. Mathematics makes me feel uncomfortable.

A Strongly Disagree B Disagree C Neutral D Agree E Strongly Agree

21. I feel a sense of insecurity when attempting mathematics.

A Strongly Disagree B Disagree C Neutral D Agree E Strongly Agree

22. I learn mathematics easily.

A Strongly Disagree B Disagree C Neutral D Agree E Strongly Agree

23. I am confident that I could learn advanced mathematics.

A Strongly Disagree B Disagree C Neutral D Agree E Strongly Agree

24. I have usually enjoyed studying mathematics in school.

A Strongly Disagree B Disagree C Neutral D Agree E Strongly Agree

25. Mathematics is dull and boring.

A Strongly Disagree B Disagree C Neutral D Agree E Strongly Agree

26. I like to solve new problems in mathematics.

A Strongly Disagree B Disagree C Neutral D Agree E Strongly Agree

27. I would prefer to do an assignment in math than to write an essay.

A Strongly Disagree B Disagree C Neutral D Agree E Strongly Agree

28. I would like to avoid using mathematics in college.

A Strongly Disagree B Disagree C Neutral D Agree E Strongly Agree

29. I really like mathematics.

A Strongly Disagree B Disagree C Neutral D Agree E Strongly Agree

30. I am happier in a math class than in any other class.

A Strongly Disagree B Disagree C Neutral D Agree E Strongly Agree

31. Mathematics is a very interesting subject.

A Strongly Disagree B Disagree C Neutral D Agree E Strongly Agree

32. I am willing to take more than the required amount of mathematics.

A Strongly Disagree B Disagree C Neutral D Agree E Strongly Agree

33. I plan to take as much mathematics as I can during my education.

A Strongly Disagree B Disagree C Neutral D Agree E Strongly Agree

34. The challenge of math appeals to me.

A Strongly Disagree B Disagree C Neutral D Agree E Strongly Agree

35. I think studying advanced mathematics is useful.

A Strongly Disagree B Disagree C Neutral D Agree E Strongly Agree

36. I believe studying math helps me with problem solving in other areas.

A Strongly Disagree B Disagree C Neutral D Agree E Strongly Agree

37. I am comfortable expressing my own ideas on how to look for solutions to a difficult problem in math.

A Strongly Disagree B Disagree C Neutral D Agree E Strongly Agree

38. I am comfortable answering questions in math class.

A Strongly Disagree B Disagree C Neutral D Agree E Strongly Agree

39. A strong math background could help me in my professional life.

A Strongly Disagree B Disagree C Neutral D Agree E Strongly Agree

40. I believe I am good at solving math problems.

A Strongly Disagree B Disagree C Neutral D Agree E Strongly Agree

(Tapia, 1996)

FACTORS AFFECTING THE FREQUENCY OF ICT USAGE IN PRIMARY SCHOOLS TEACHING

Vasilka VITANOVA

Faculty of Computer Science, University "Goce Delcev" Stip, R.Macedonia

e-mail: vasilka_v@yahoo.com

Tatjana ATANASOVA-PACHEMSKA**

Faculty of Computer Science, University "Goce Delcev" Stip, R.Macedoni

e-mail: tatjana.pacemska@ugd.edu.mk

Sanja PACHEMSKA

Bureau for Development of Education of the Republic of Macedonia, Skopje, R. Macedonia

ABSTRACT: Intensive and rapid development of ICT lead to popularization and necessity of its use, and changes in all spheres including education as a process.

A research was conducted in order to ensure valid and reliable assessment of the extent and nature of ICT knowledge and skills of teachers in primary schools, to identify the factors that affect the frequency of use of ICT in teaching and to identify strategies for enhancing development effectiveness future.

The research surveyed 214 teachers from 10 primary schools in the Southeast region of Macedonia. Technique Modeling of Structural Equations was used to determine the relative strength of the factors affecting the frequency of use of ICT in teaching. The results show that the highest percentage of 58.4 % of the teachers often use ICT in teaching, 33.6 % rarely use ICT, 7 % of respondents use ICT at all times, and only 0.9 % do not use ICT for teaching purposes. ICT competencies of teachers, number of training, years of computer use, possession of personal computer and having Internet at home proved as influential factors for ICT usage frequency in teaching.

The survey results were analyzed using SPSS 19, Excel and Amos Graphics 18.

Keywords: ICT knowledge and skills, ICT in teaching, modeling with structural equations.

1. INTRODUCTION

Information and communication technologies (ICT) play a proven critical role in enhancing the quality of education. They are particularly important in helping teachers and students to perform more effectively. To make the best use of ICT, teachers must be equipped with adequate ICT competencies. In the process of integrating ICT into education, both teacher's ICT competencies and how they perceive the role of ICT in their teaching/learning processes play key roles. Analysis, design, development, implementation, evaluation, and management of ICT in education require diversified competencies and knowledge (Kozma 2002, pp.1-6).

ICTs have become within a very short time, one of the basic building blocks of modern society. Many countries now regard understanding ICT and mastering the basic skills and concepts of ICT as part of the core of education, alongside reading, writing and numeracy (Daniels, 2002).

Today, improved communication technology has made time and space less complex. It could be observed that this modern age is the age of information explosion in which an average individual wants to explore the information system. Thus, the ability for timely acquisition, utilization, communication and retrieval of relevant

and accurate information has become an important attribute for better teaching-learning process (Adebayo, 2008).

The new technologies have the potential to support education across curriculum and provide opportunities for effective communication between teacher and students in ways that have not been possible before. ICT in education has the potential to be influential in bringing about changes in ways of teaching (Dawes, 2001).

The field of education has been affected by ICTs, which have undoubtedly affected teaching, learning, and research (Yusuf, 2005). A great deal of research has proven the benefits to the quality of education (Al-Ansari, 2006). ICTs have the potential to innovate, accelerate, enrich, and deepen skills, to motivate and engage students, to help relate school experience to work practices, create economic viability for tomorrow's workers, as well as strengthening teaching and helping schools change (Davis and Tearle, 1999; Lemke and Coughlin, 1998; cited by Yusuf, 2005). As Jhurree (2005) states, much has been said and reported about the impact of technology, especially computers, in education. The field of education has been affected by ICTs, which have undoubtedly affected teaching, learning and research (Yusuf, 2005). ICTs have the potential to accelerate, enrich, and deepen skills, to motivate and engage students, to help relate school experience to work practices, create economic viability for tomorrow's workers, as well as strengthening teaching and helping schools change (Davis and Tearle, 1999; Lemke and Coughlin, 1998; cited by Yusuf, 2005).

Teachers contribute toward the base of the education innovation, therefore ICT competencies of teachers in primary schools should be seen as an invaluable prerequisite to facilitate teaching and learning in this modern era of information and technology. [9]

ICT is not only a means of realizing the educational goals but important factor in a complete restructuring of the educational system, introducing new interactive and participatory models of education, new educational pedagogy, continuous and lifelong learning.

Macedonian context of computerization and digitization of education intensively developed after 2002 when the country received the first Chinese donation, which allowed a certain degree of popularization of ICT in the education. Starting in 2003 through the e-school project teacher training the use of ICT were conducted in two phases. With changes in education that occurred with the intensive introduction in education, resulted in a need to develop national educational policies and strategies that will contribute to the social and educational development. In 2005 was created the draft program for the development of ICT in education (2005-2015) which covered the process of computerization and digitization of education.

Macedonia entered the world of ICT innovation with the introduction of the program "Computer for Every Child" initiative and investment by the Government of the Republic of Macedonia to modernize Macedonian education. This project provides a computer for each child, software solutions and tools for each subject, advanced ICT skills among teachers and students, a national system of testing students and the interactive online teaching.

In the academic year 2009/2010, primary schools were equipped with portable Classmate PCs for every student from first to third grade. In 2010 teacher trainings were conducted for Edubuntu operating system, the programs for integration of mathematics and sciences, ToolKid program and SSTC of using "thin clients". Furthermore, despite the software electronic grades were introduced. Also attached is training for class teachers for the program and Green G Compris suite-junior. [5,6,8]

Starting from the academic year 2013/14, all teachers were required to integrate at least 30% of ICT in the curriculum.

2. METHODOLOGY

In the survey every teacher had to report their ICT knowledge and skills, the ways in which they use ICT in teaching, ICT training they have attended, frequency of ICT use in teaching and to evaluate motivational attitudes of the ICT use in teaching, and the attitudes of the school towards ICT. The main parts of the survey are shown in Table 1.

This research is done in order to ensure a valid and reliable assessment of the extent and nature of ICT knowledge and skills of teachers in primary schools, and to identify factors that affect the frequency ICT usage in teaching.

The survey was conducted in the academic year 2012/13, in 10 primary schools in the Southeast region of the Republic of Macedonia in the municipalities of Strumica, Vasilevo, Bosilevo and Novo Selo. The survey was

conducted on 214 teachers, a representative sample in given that 610 is the total number of teachers in those municipalities.

Table 1. Structure Of The ICT Survey In Teaching For Teachers In Primary Schools.

part	Title of section	Information	Number of issues
I	General information	environment, age, experience, sex, teacher	5
II	Using the computer for personal needs	personal computer, type of computer, Internet at home, years of experience with computer	4
III	Personal and professional development	training classes at school, additional training, self-improvement	3
IV	Using computers at school	implementation of ICT programs, type of computer, hardware, use of computer	6
V	Motivation for using ICT in teaching	motivational view with scale assessment	21
VI	ICT knowledge and skills	navigation in the operating system, email, Internet, text editor, multimedia presentations, spreadsheet calculations, blogs, databases	8
VII	ICT in school	assessment scale for the application of ICT in school	3
Total Questions			33

3. RESULTS AND DISCUSSION

The survey results were analyzed using SPSS 19 programs, Excel and Amos Graphics 18. The tables below present the demographic characteristics of the surveyed teachers.

Table 2. The location of the school.

		Location			
		Frequency	Percent	Valid Percent	Cumulative Percent
Valid	Rural	105	49,1	49,1	49,1
	Urban	109	50,9	50,9	100,0
	Total	214	100,0	100,0	

Table 2 Shows That Almost Equal Number Of Teachers Are From Urban And Rural Areas.

Table 3. Age Structure Of The Surveyed Teachers.

		Age			
		Frequency	Percent	Valid Percent	Cumulative Percent
Valid	<=25	5	2,3	2,3	2,3
	>=56	24	11,2	11,2	13,6
	26-35	59	27,6	27,6	41,1

36-45	55	25,7	25,7	66,8
46-55	71	33,2	33,2	100,0
Total	214	100,0	100,0	

Table 4. Work experience as a teacher.

Experience

	Frequency	Percent	Valid Percent	Cumulative Percent
Valid <=5	46	21,5	21,5	21,5
>=26	51	23,8	23,8	45,3
11-15	29	13,6	13,6	58,9
16-20	22	10,3	10,3	69,2
21-25	19	8,9	8,9	78,0
6-10	47	22,0	22,0	100,0
Total	214	100,0	100,0	

Table 5. Gender of surveyed teachers.

Gender

	Frequency	Percent	Valid Percent	Cumulative Percent
Valid Female	177	82,7	82,7	82,7
Male	37	17,3	17,3	100,0
Total	214	100,0	100,0	

Table 6. Teachers from primary education.

Teacher

	Frequency	Percent	Valid Percent	Cumulative Percent
Valid Primary education teacher	85	39,7	39,7	39,7
Subject teacher	129	60,3	60,3	100,0
Total	214	100,0	100,0	

Figure 1 is a graphical representation of a given application of ICT in teaching. The question: Do you use ICT in teaching, teachers had to answer whether they do it all the time, rarely, never, or don't know what it is. The largest percentage of 58.4% reported that they use ICT often, 33.6% rarely use ICT, 7% of the respondents use ICT at all times, and only 0.9% do not use ICT for teaching purposes.

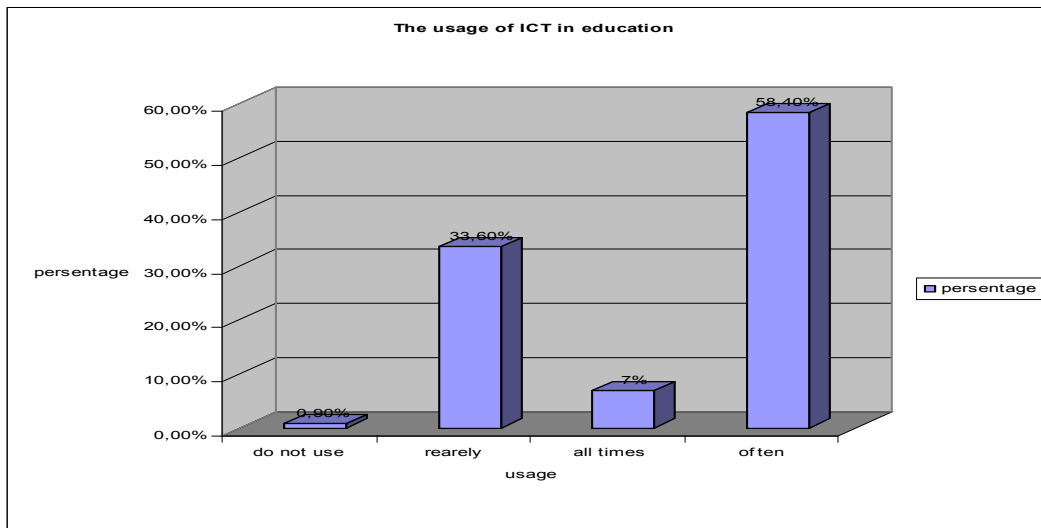

Figure 1. The usage of ICT in education.

The survey asked teachers who use ICT in teaching to also assess the frequency, i.e. if they apply it daily, weekly, monthly, or a few times a year. Figure 2 shows the frequency of ICT usage. The largest percentage of 49.10 % applied ICT weekly, 20.60 % applied ICT monthly, 17.80 % a few times a year, and the smallest percentage of 11,70 % use ICT every day. The frequency of ICT usage in teaching depends on the nature of the subject that the teacher teaches and the requirements for the application of ICT in the teacher's curriculum.

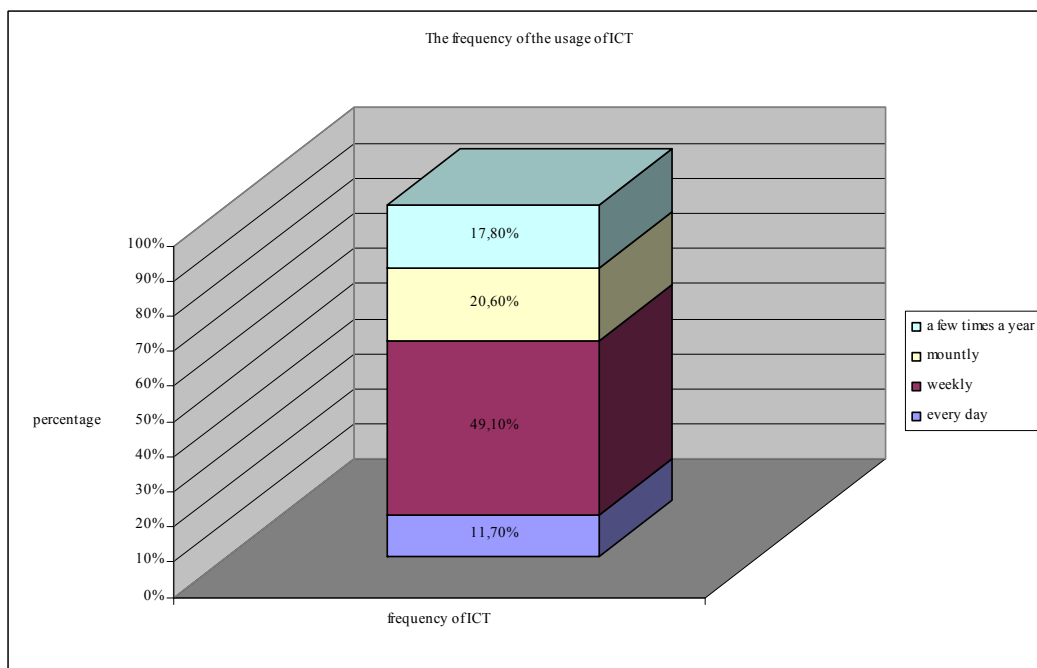

Figure 2. The frequency of the usage of ICT.

According to the frequency of ICT usage, the teachers can be classified into three categories: low, medium and high. The low category, 34.1% of the surveyed teachers, includes teachers who rarely or never use ICT and if they do use it, it is a few times a year or month. The medium category, involved the highest percentage of respondents 52.3%, includes teachers who often use ICT in teaching. The high category, involved the lowest percentage of 13.5 % respondents, includes teachers who use ICT at all times, or every day.

By analyzing all demographic factors such as gender, environment, age, seniority, years of experience, and the kind of teacher we cannot single out any demographic factor that shows statistically significant correlation with the frequency of ICT usage in teaching.

The technique of structural equation modeling was used again to analyze the relationship between the frequency of ICT usage and the other factors.

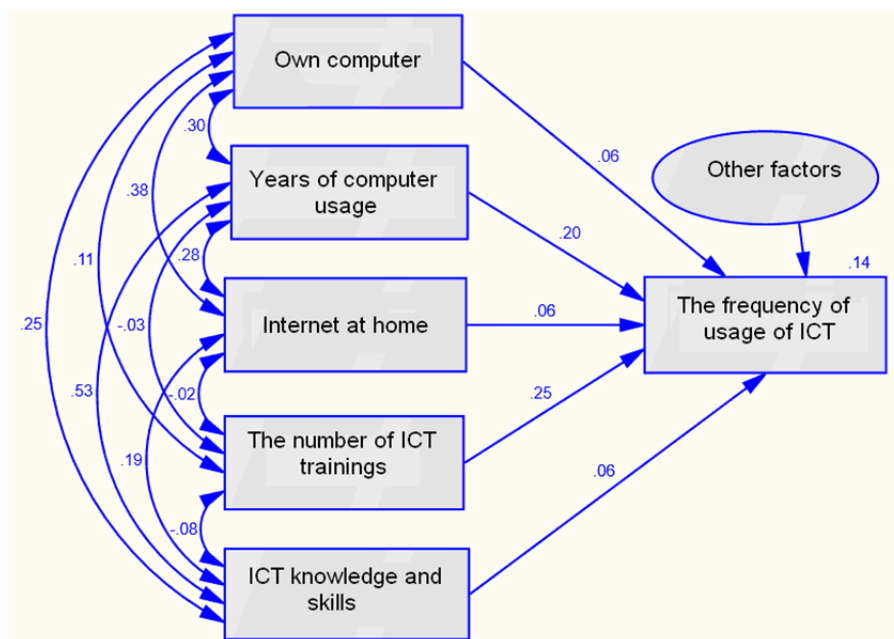

Figure 3. The relative strenght of influence on the factors on the frequency of usage of ICT.

From Figure 3 we can conclude that the number of ICT trainings is a factor with the strongest influence on the frequency of ICT usage - measured 0.25, then comes years of computer usage - measured 0.20, and the remaining three factors: own computer, have Internet at home, and have ICT knowledge and skills - measured 0.06. The impact of other factors on ICT knowledge and skills is 0.14.

When we add the results of all five factors that influence the frequency usage of ICT, we obtain value 0.63 (0 to 1). This means that all these factors are 63% of the variance in frequency of ICT usage, suggesting that these factors describe the impact on frequency of ICT usage well.

Table 7. The regressional weight of the factors for the frequency if the usage of ICT.

Regression Weights: (Group number 1 – Default model)

		Estimate	S.E.	C.R.	P	Label
The frequency of ICT usage	←-Own computer	.266	.325	.818	.414	
The frequency of ICT usage	←-Years of computer usage	.289	.110	2.636	.008	
The frequency of ICT usage	←-Internet at home	.373	.464	.804	.421	
The frequency of ICT usage	←-Number of ICT training	.238	.060	3.964	***	
The frequency of ICT usage	←-ICT knowledge and skills	.002	.003	.758	.449	

Table 7 is a textual display of the results using AMOS Graphics. As we can see only the factor *Number of ICT training* has a significant positive effect on the frequency of ICT usage, with value of $p < 0.001$. Years of computer usage have a positive significant effect on the frequency of ICT usage, with value of $p < 0.05$. The rest of the factors have a positive insignificant effect on the frequency of ICT usage, with a value of p greater than 0.05.

Table 8. Overview of the model in SPSS.

Model Summary

Model	R	R Square	Adjusted R Square	Std. Error of the Estimate
1	,380 ^a	,144	,124	1,376

a. Predictors: (Constant), ICT knowledge and skills, Number of ICT training, Internet at home, Own computer, Years of computer usage

Table 8 gives us a summary of the model in SPSS, where we can see that the value of R Square is 0.144, indicating a good model.

Table 9. ANOVA table for the cumulative effect on SPSS.

ANOVA^b

Model		Sum of Squares	df	Mean Square	F	Sig.
1	Regression	66,457	5	13,291	7,018	,000 ^a
	Residual	393,917	208	1,894		
	Total	460,374	213			

a. Predictors: (Constant), ICT knowledge and skills, Number of ICT training, Internet at home, Own computer, Years of computer usage

b. Dependent Variable: The frequency of usage of ICT

As we can see from the ANOVA table, the cumulative effect is significant.

Table 10. Table of coefficients in SPSS.

Coefficients^a

Model		Unstandardized Coefficients		Standardized Coefficients	t	Sig.
		B	Std. Error	Beta		
1	(Constant)	1,060	,479		2,213	,028
	Own computer	,266	,329	,058	,808	,420
	Years of computer usage	,289	,111	,204	2,605	,010
	Internet at home	,373	,470	,056	,795	,428
	Number of ICT training	,238	,061	,255	3,917	,000
	ICT knowledge and skills	,002	,003	,057	,749	,455

a. Dependent Variable: The frequency of usage of ICT

From Table 10 we see that the the Beta coefficients of all predictors are positive, but only Number of ICT training and years of computer use are significant, the rest of the factors are insignificant.

4. CONCLUSION

Since the ultimate goal is to achieve higher frequency of the ICT usage in teaching, then according to the factors that contribute to it, are moving a step forward.

- o Increased ICT competencies of teachers positively influence the increase of frequency ICT usage in teaching.
- o Certainly the experience of working with computer positively affects the increase of ICT competencies of teachers, and thus the frequency of ICT usage in teaching.
- o Increased number of training courses and similar improvements increase the frequency of ICT usage in teaching.
- o The use of Internet at home does not limit a teacher to work in preparation for teaching and contributes to increase of the frequency of ICT usage in teaching.
- o Having computer certainly has a positive influence on the frequency of ICT usage in teaching.

REFERENCES

- [1] Atanasova-Pacemska, T. (2012). *Structural equation modeling and application in data analyzing*. In: Invitation lecture, January 2012, University of Zagreb – Faculty of Food Technology and Biotechnology.
- [2] Goktas, Y., Yildirim, Z., & Yilidrim, S. (2009). Investigation of K-12 Teachers' ICT Competencies and the Contributing Factors in Acquiring these Competencies. *The New Educational Review*, 17(1), 276-294.
- [3] Grace, J. (2006). *Structural Equation Modeling and Natural Systems*, Cambridge Univ. Press.
- [4] Iliev, D., Atanasova Pachemska, T. (2012). Teacher Competences between Yesterday and Tomorrow-Macedonian Case Study, 4th World Conference on educational sciences (WCES 2012) 02-05 February 2012 Barcelona, Spain.
- [5] Ministry of Education and Science. (2005). Draft program for the development of ICT in education (2005-2015). Retrieved from: <http://www.npro.edu.mk/dokumenti/PROGRAMI/IKT.pdf>
- [6] Primary Education Project PEP USAID, Retrieved from: http://www.pep.org.mk/en/ict/ict_index.htm
- [7] Teacher ICT skills: evaluation of the Information and Communication Technology (ICT) knowledge and skills levels of the Western Australian government school teachers. (2006). East Perth WA, Department of Education and Training.
- [8] USAID. (2006). Survey on the use of computers and Internet in Macedonia, Skopje. Retrieved from: <http://macedonia.usaid.gov/Documents/Internet%20and%20Computer%20Usage%20Report%206%20MK.pdf>
- [9] Vitanova V., Atanasova-Pachemska T., Iliev D., Pachemska S. (2014). *Factors affecting the development of ICT competencies of teachers in primary schools*, WCES 2014, presented and accepted for publishing at *Procedia-Social and Behavioral Sciences Journal* (ISSN: 1877-0428).

ÖĞRENCİLERİN PROBLEME DAYALI ÖĞRENME YÖNTEMİNİN UYGULANMASI HAKKINDAKİ DEĞERLENDİRMELERİ

Ahmet ELBİSTANLI
Milli Eğitim Bakanlığı
ahmetelbistanli@hotmail.com

Cengiz TÜYSÜZ
Mustafa Kemal Üniversitesi Eğitim Fakültesi
ctuysuz@mku.edu.tr

Bilal YILDIRIM
Mustafa Kemal Üniversitesi Eğitim Fakültesi
byildirim@mku.edu.tr

Erdal TATAR
Mustafa Kemal Üniversitesi Eğitim Fakültesi
etatar@mku.edu.tr

ÖZET: Bu çalışmada 11. sınıf kimya dersi kimyasal denge konusunun probleme dayalı öğrenme (PDÖ) yöntemi ile işlenmesi hakkındaki öğrenci görüşlerinin elde edilmesi amaçlanmıştır. Bu amaçla; 30 öğrencinin bulunduğu bir sınıfta kimyasal denge konusunun PDÖ yöntemi ile işlenmesinin ardından öğrencilere PDÖ değerlendirme anketi, grup çalışmalarını değerlendirme anketi ve öğrencilerin kendini değerlendirme anketi uygulanmıştır. PDÖ değerlendirme ölçeğinden elde edilen verilerin analizi sonucunda yüksek bir ortalama elde edilmiştir. Ölçeğe verilen cevaplar incelendiğinde; öğrencilerin PDÖ yöntemi ile kendilerine olan güven duygusunun arttığını, araştırma yapıp bunları derslerde kullanabilmeyi öğrendiklerini, karşılaştıkları problemlere çözümler üretebilme ve bu çözümleri analiz edebilme yeteneklerinin arttığını ifade ettikleri görülmektedir. Öğrenciler bu ölçekteki açık uçlu sorulara kimyayı bu şekilde öğrenmenin eğlenceli olduğunu düşündüklerini ve araştırma yapmayı ve konuların kitap dışında da olduğunu görmeyi olumlu buldukları cevaplarını vermişlerdir. Bununla birlikte öğrenciler araştırma imkânlarının sınırlı olduğunu, konunun uzadığını, az soru çözüldüğünü, araştırma süresinin yetersiz olduğunu belirtmişlerdir. Grup çalışmalarını değerlendirme anketinden elde edilen verilerin analizi sonucunda yüksek bir ortalama elde edilmiştir. Öğrenciler ölçekteki sorulara; grup çalışmalarında karşılıklı saygı ve işbirliği geliştirdikleri, grup halinde öğrenmeyi olumlu buldukları cevaplarını vermelerinin yanında, grup içi işbirliğinin ve görev paylaşımının istenen seviyede olmadığı ve grupların öğrenciler tarafından oluşturulmasının daha iyi olacağı yönünde cevaplar da verilmiştir. Öğrencilerin kendilerini değerlendirme anketinden elde edilen verilerin analizi sonucunda öz başarı hususunda yüksek bir ortalama elde edilmiştir. Öğrenciler ölçekteki sorulara, süreç boyunca derslere ilgi gösterdikleri ve kendilerine verilen görevleri yerine getirdikleri, genel olarak kendilerini başarılı buldukları cevabını vermekle beraber birkaç öğrenci grupta sadece kendisinin çaba sarf ettiğini, bazıları ise geri planda kaldıklarını belirtmiştir. Ayrıca kimya dersini anlayamadığı için kendisinin başarısız olduğunu düşünen öğrenciler de vardır. Sonuç olarak öğrencilerin PDÖ yöntemi hakkında bazı geliştirilmesi gereken hususların olduğunu düşünmeleriyle beraber olumlu görüşlere sahip oldukları tespit edilmiştir.

Anahtar sözcükler: probleme dayalı öğrenme, grup çalışması, kimyasal denge, kimya öğretimi

DETERMINATION OF STUDENTS' REVIEWS ABOUT APPLICATION OF PROBLEM BASED LEARNING

Ahmet ELBİSTANLI
Ministry of Education
ahmetelbistanli@hotmail.com

Cengiz TÜYSÜZ
Mustafa Kemal University, Faculty of Education
ctuysuz@mku.edu.tr

Bilal Yıldırım
Mustafa Kemal University, Faculty of Education
byildirim@mku.edu.tr

Erdal TATAR
Mustafa Kemal University, Faculty of Education
etatar@mku.edu.tr

ABSTRACT: In this study it has been aimed to obtain the 11th grade students' opinion about carrying out the problem-based learning (PBL) method in chemical equilibrium topic in chemistry. For this purpose; PBL assessment questionnaire, group study assessment questionnaire and self-assessment questionnaire have been applied to 30 students after chemical equilibrium topic has been studied. Analysis results of the PBL questionnaire have shown a high average. According to the answers given to the questionnaire, students have had more self-confidence with PBL method, have learned how to search and use the findings in the class, and have had more ability to produce and analyze solutions to problems which they have faced. According to the responses to open-ended questions in this questionnaire; students think that learning chemistry with PBL is entertaining, and they take a bright view of searching for the lesson and discerning the topics not only in the book, but also in elsewhere. Nevertheless, students have pointed out that research opportunities and period were limited; PBL was taking more time and limiting problem solving activities. Analysis results of the group study assessment questionnaire have shown a high average. Students have answered to the questionnaire that they have enhanced collaboration and mutual respect, and have approved to learn with the group. Despite, they have pointed out that cooperation and task-sharing among the group member weren't at the desired level and it would be better to create the groups by themselves. Analysis results of the self-assessment questionnaire have shown a high average in self success. However, students have answered that they have shown interest in course along the process, fulfilled the tasks given to them and found themselves successful, some students have stated that only they made an effort and some others expressed that that they remained in the background. Also some students thought themselves as unsuccessful because of they couldn't understand the chemistry. As conclusion, it has been determined that students have positive opinions about PBL method while they think that PBL method has some matters must be developed.

Keywords: Problem based learning, teamwork, chemical equilibrium, chemistry education

GOLF SPORU YAPAN BİREYLERİN DİKKAT DÜZEYLERİNİN İNCELENMESİ

Ahmet TUNÇ

Mehibe AKANDERE

Gülsüm Baştuğ

Selçuk Üniversitesi Beden Eğitimi ve Spor Yüksek Okulu

Konya -Kampüs

ÖZET: Bu çalışmanın amacı, golf sporu egzersizinin 14-15 yaş grubu bireylerde dikkat düzeyini etkileyip etkilemediğinin araştırılmasıdır. Çalışmanın örneklem grubu Konya ili Selçuklu ilçesi Mehmet Halil İbrahim Hekimoğlu Ticaret Meslek Lisesinde okuyan 14-15 yaş grubu 60 öğrenci oluşturmaktadır. Araştırmaya deney gurubu olarak katılan deneklerin yaş ortalaması $14,80 \pm 1,38$ yıl, kontrol gurubunun yaş ortalaması ise $14,90 \pm 1,39$ yıldır. 8 haftalık sürecin öncesinde ve sonrasında hem kontrol hem denek gruplarına Bourdon (1955) dikkat testi uygulanmıştır.

Verilerin değerlendirilmesinde ve hesaplanmış değerlerin bulunmasında SPSS 16.0 istatistik paket program kullanılmıştır. Veriler yüzde ve frekans tabloları erilerek özetlenmiştir. Verilerin normal dağılım gösterip göstermediği One-Sample Kolmogorov-Smirnov testi ile test edilmiş ve verilerin normal dağılım gösterdiği tespit edilmiştir. Veriler normal dağılım gösterdiği için guruplar arasındaki farklılığın tespiti için independed sample t testi kullanılmıştır. Gurup içi ön test – son test karşılaştırmalarında ise, paired samples t testi kullanılmıştır. Bu çalışmada hata düzeyi 0.05 olarak alınmıştır.

Araştırmaya katılan deney ve kontrol grubu arasında son test bakımından istatistiksel olarak anlamlı bir farklılık olduğu tespit edilmiştir ($p < 0,05$). Araştırmaya deney grubu olarak katılan deneklerin ön test – son test karşılaştırılmasında, ön test ve son test değerleri arasında istatistiksel olarak anlamlı bir farklılık olduğu tespit edilmiştir ($p < 0,05$). Bu karşılaştırmalarda son test değerlerinin ön test değerlerinden yüksek olduğu bulunmuştur. Araştırmaya katılan deneklere ilişkin ön test ve son test değerlerinin aylık gelir durumu bakımından karşılaştırılmasında, aylık gelir durumları arasında deney grubu bakımından ön test ve son test sonuçları arasında istatistiksel olarak anlamlı farklılık tespit edilmiştir ($p < 0,05$). Ancak kontrol gurubu bakımından aylık gelir durumlar arasında istatistiksel olarak anlamlı bir farklılık tespit edilememiştir ($p > 0,05$).

Sonuç olarak, golf sporu egzersizi yapan 14-15 yaş grubu bireylerin dikkat düzeylerinin incelenmesi amacı ile yapılan çalışmada, deney grubuna uygulanan golf sporu egzersizinin çocukların dikkat düzeylerinde anlamlı farklılığa neden olduğu bulunmuştur. Bu bağlamda golf sporu egzersizinin 14-15 yaş grubu çocuklarda dikkat özelliklerini olumlu yönde etkilediğini söyleyebiliriz.

Anahtar Sözcükler: Çocuk, dikkat, egzersiz, golf sporu

THE ANALYSIS OF THE ATTENTION LEVELS OF INDIVIDUALS PLAYING GOLF

ABSTRACT:The purpose of this study is to investigate whether the golf exercises effect the attention level of the individuals in 14-15 years of age. The sample group of the study is occuring 60 students in 14-15 age group from Hekimoğlu Ticaret Meslek High School located in Selçuklu District of Konya. The mean age of the subjects participating in the study as the experimental group is 14.80 ± 1.38 years, mean age of the control group is 14.90 ± 1.39 years. Before and after the 8 weeks process Bourdon (1955) attention test is applied.

SPSS 16.0 programme is used in evaluation and using the calculated values. Datas are summarized in the percentage and frequency tables. The test of the datas distribution is normal or not made by One-sample Kolmogorov-Smirnov test method and fixed that datas have normal distribution. Because of the datas have normal distribution, to fix the differences of the groups independent sample t test is applied. For the pre-test – post test comparisons in the group paired samples t test is used. In this study the error level is set as 0.05. it is fixed that there is a significant difference between experimental group and control group in the final test ($p < 0,05$). It is fixed that there is a statistically significant difference between pre test and post test values in the comparison of the pre test and post test of the subjects who participated to the survey. ($p < 0,05$). In this comparisons it is found that the post test values are higher then pre test values. In the comparison of the monthly income status of the pre test and post test values of the participants, it is fixed that there is statistically significant difference between monthly income statuses of the participants in terms of experiment group. ($p < 0,05$). However for the control group there is not any statistically significant difference between monthly income statuses. ($p > 0,05$).

As a result, in the survey made for inspecting the attention levels of the individuals in 14 – 15 age group who are making golf excersises, it is fixed that the golf excersise applied to the test gruop effects the attention level of the kids significiantly. In this context, we can say that the golf excersise positively effect the attention properties of the kids in 14-15 age group.

Key words: Kid, attention, exercise, golf

FUTBOL BRANŞINA KATILAN 9-14 YAŞ GRUBU ERKEK ÇOCUKLARIN IŞIK REAKSİYON ZAMANLARININ BELİRLENMESİ

Hayrunisa BOYAR

Mehibe AKANDERE

Gülsüm BAŞTUĞ

Selçuk Üniversitesi Beden Eğitimi ve Spor Yüksek Okulu
Konya – Kampüs

ÖZET: Bu çalışmada; yaz spor okulu programına katılan, spora yeni başlayan çocukların ışık reaksiyon zamanlarının belirlenmesi amaçlanmıştır.

Bu çalışma; Konya ili merkezinde bulunan Konya Beşiktaş Spor Okulu (Kara kartallar Spor Okulu)'na katılan 9-14 yaş grubu erkek futbolcular üzerinde uygulanmıştır. Deney grubuna uygulanan çalışmada gönüllü 80 kişi katılmıştır. Herhangi bir ön seçim uygulanmamıştır. Araştırmamızda 9-14 yaş grubu çocuklara 16 haftalık, haftada üç gün ikişer saat temel futbol antrenman programı uygulanmıştır. Uygulanan 16 haftalık temel futbol antrenmanları ile çocukların reaksiyon zamanlarında herhangi bir değişme olup olmadığını incelemiştir.

Verilerin değerlendirilmesinde ve hesaplanmış değerlerin bulunmasında SPSS 16.0 istatistik paket programı kullanılmıştır. Veriler ortalama ve standart sapmalar verilerle özetlenmiştir. Verilerin normal dağılım gösterip göstermediği One-SampleKolmogorov-Smirnov testi ile test edilmiş ve verilerin normal dağılım göstermediği tespit edilmiştir. Veriler normal dağılım göstermediği için bağımsız değişkenler arasındaki farklılığın tespiti için Mann Whitney-U testi, bağımlı değişkenler arasındaki farklılığın tespiti için ise Wilcoxon testi kullanılmıştır. Bu çalışmada hata düzeyi 0.05 olarak alınmıştır.

Araştırmaya katılan deney grubu ön test – son test değerlerinin karşılaştırılmasında, vücut ağırlığı, vücut kütle indeksi, görsel reaksiyon zamanı sol değişkenleri bakımından istatistiksel olarak anlamlı bir farklılık tespit edilmemiştir. ($P>0,05$) Buna karşın yağ%, görsel reaksiyon zamanı sağ değişkeni bakımından ön test – son test değerleri arasında istatistiksel olarak anlamlı bir farklılık tespit edilmiştir ($P<0,05$). Bu karşılaştırmada yağ%, görsel reaksiyon zamanı sağ için elde edilen ön test değerleri yağ%, görsel reaksiyon zamanı sağ için elde edilen son test değerlerinden anlamlı derecede daha yüksek bulunmuştur ($P<0,05$).

Araştırmaya katılan kontrol grubu ön test – son test değerlerinin karşılaştırılmasında, görsel reaksiyon zamanı sağ, görsel reaksiyon zamanı değişkenleri bakımından istatistiksel olarak anlamlı bir farklılık tespit edilmemiştir ($P>0,05$). Buna karşın vücut ağırlığı, vücut kütle indeksi ve yağ% değişkenleri bakımından ön test – son test değerleri arasında istatistiksel olarak anlamlı bir farklılık tespit edilmiştir ($P<0,05$). Bu karşılaştırmada vücut ağırlığı, vücut kütle indeksi ve yağ% için elde edilen ön test değerleri vücut ağırlığı, vücut kütle indeksi ve yağ% için elde edilen son test değerlerinden anlamlı derecede daha düşük bulunmuştur ($P<0,05$).

Bu çalışmada; futbol branşında veya farklı branşlarda uygulanacak olan antrenmanın şiddeti ve yoğunluğunun yanında düzenli reaksiyon programının uygulanmasını gerektirdiği kanısına varılmıştır.

Anahtar Sözcükler: Reaksiyon zamanı; futbol; antropometri

DETERMINING THE TIME OF LIGHT REACTION OF THE MALE CHILDREN BETWEEN 9 AND 14 YEARS OLD WHO ATTENDED THE FOOTBALL BRANCH

Hayrunisa BOYAR

Mehibe AKANDERE

Gülsüm BAŞTUĞ

Selçuk Üniversitesi Beden Eğitimi ve Spor Yüksek Okulu
Konya – Kampüs

ABSTRACT: In this study: The aim was to determine the time of light reaction time in children who had been involved in summer sport school and had just started doing sport.

This study: It has been applied on children who had been involved in Konya Beşiktaş Sport Club(Kara Kartallar Spor Okulu) in Konya City Centrum and who were 9-14 aged male soccers.80 volunteers participated in this experiment. There was not any pre-election. In this study, Basic football training program put into practice on children who are 9-16 age range for 16 weeks which is 2 hours in a week. As a result of 16 weeks basic football training, It was observed that whether there were any changes in reaction time or not.

SPSS 16.0 Statistical packet program was used in evaluating data and finding calculated values. Data were summarized in light of average and standard deviation. One-Sample Kolmogorov-Smirnov test was used in order to test whether there were any normal distribution in data and it was ascertained that data did not show normal distribution. Because data did not show normal distribution, Man Whitney-U test was used in order to determine variety among independent variables, and Wilcoxon test was used to determine variety among dependent variable. Error was taken as 0.05 in this study.

It was not observed semantic variety statistically in terms of body weights, body mass index, visual reaction time left variables in comparing pre-final test values of experiment group involved in research($P>0,05$). Despite that fat%, in terms of visual reaction time sağ variable , was determined to be semantic differences between pre - final test values statistically ($P<0,05$). In this comparison fat% was found to be significantly higher than final test values obtained for visual reaction time right. ($P<0,05$)

It was observed semantic difference statistically in terms of visual reaction time right, visual reaction time variables in comparing pre-final test values of experiment group involved in research($P>0,05$). In spite of that, in terms of body weights, body mass index and fat% variables, it was determined to be semantic differences between pre - final test values statistically ($P<0,05$). In this comparison, body weights, body mass index and fat% pre-test values were found meaningfully lower than body weights, body mass index and fat% final-test values ($P<0,05$).

In this study; it was concluded that it is necessary to apply regular reaction program as well as severities and intensity of training in soccer or different branches.

Keywords: Reaction time; football; anthropometry

THE EFFECT OF PRACTICES IN THE LABORATORY COURSE ON THE DEVELOPMENT OF SCIENTIFIC PROCESS SKILLS OF TEACHER CANDIDATES

Eylem EROĞLU DOĞAN

Yunus ÖZYURT

The purpose of science education is to train learners as science literate individuals. It is fundamental to have students gain essential knowledge about science as well as learn how to access knowledge during this process. As it is known that scientific process skills (SPS) of individuals can be developed starting from the early ages so the importance of classroom teachers having sufficient knowledge about this issue becomes more clear. The aim of this research is to examine the effect of the course designed to improve scientific process skills of classroom teacher candidates on redounding these process skills. In the study, survey and document analysis methods are used and one group pretest-posttest experimental design was adopted. The research sample is composed of 2nd year undergraduate elementary teacher candidates (N=41) at Abant İzzet Baysal University . In the study, Integrated SPS Test (Geban, Aşkar & Özkan, 1992) and rubrics prepared by the researcher with the aim of assessing lab reports and experiments designed by the participants were used as data collection instruments. Teacher candidates having been done experiments designed for the development of their science process skills for seven weeks and lab reports written by them were collected and assessed. SPS test was administered as pretest-posttest before and after the experiments having been performed. After the intervention, teacher candidates were asked to design experiments that can be used in elementary school grade 3 level science lessons for developing science process skills. The use and content of the experiments designed by teacher candidates were assessed in terms of overlap with science process skills. In the analysis of data obtained, frequency distributions and paired samples t-test were used. The findings revealed that science process skills of teacher candidates in this laboratory course were improved and they could applied them into practice.

Keywords: Scientific proses skills, laboratory practice, teacher candidate

INQUIRY-BASED LEARNING IN CHINA : LESSON LEARNED FOR SCHOOL SCIENCE PRACTICES

Prasart NUANGCHALERM

This study aims to explore inquiry-based learning in teacher preparation program in China. Data were collected by qualitative methods; classroom observation, videotape recording, photography, and interviewing were employed. The results can be explained in terms of lesson learned for school science practices. It can be understandable, simply to incorporate for general science classroom, and also be implied to instructional science practices. The findings help us to understanding what inquiry-based classroom is and how inquiry-based learning are.

Keywords: inquiry-based learning, science teaching, scientific inquiry

APPLICATION OF MATHEMATICS TO TRANSPORT PHENOMENA

Norman LONEY

In the delivery of advanced engineering and science courses, it appears that the most common deficit in undergraduate students' preparation is the lack of exposure to the applications of mathematics. In order to succeed in graduate studies chemical engineering students must have more than an adequate understanding of the science of transport phenomena. However, transport phenomena are acutely coupled to the application of mathematics. While practitioners of advanced transport phenomena (Slattery, Bird et. al) frequently use mathematics as a tool to expose the behavior of complex systems this approach is not prevalent in undergraduate programs. Addressing this deficit in the undergraduate programs could have immediate positive impact on interdisciplinary and cross disciplinary communities as mathematics is the common language between all of the physical sciences. Material has been developed that is aimed at improving the level of understanding and the application of mathematics as a tool for chemical engineers. This material consists of brief descriptions of given mathematical methods followed by several complete examples demonstrating the previously described mathematical approach. There is an abundance of examples that can be adopted from current or recent physical science and engineering research literature to constitute teaching portfolios. As an example, a book was published by CRC Press in 2000) and was adopted in various chemical engineering programs in the USA. Applied Mathematical Methods for Chemical Engineers, has been adopted by 9 (nine) schools and is currently in its 2nd Ed. (January 2007). This one example indicates the need and strong opportunity for such mathematical applications to be produced and delivered to the various engineering and technology communities through existing undergraduate programs.

Keywords: transport phenomena, mathematics, applications

A NEW E-LEARNING PARADIGM: TOOLS AND TECHNIQUES

Juliet OKPO
Nigerian Defence Academy, Kaduna, Nigeria

ABSTRACT: Technology we believe can place a greater range of tools and resources at the disposal of teachers and students and one of the by-products of the speed with which things change in the era of the ICT revolution is that there is a lot of new paradigms which is explored in this work. Several of the tools and techniques available for the delivery of electronic learning are presented. Also, basic IT tools are shown to possess considerable capabilities alongside the discussions of specialized tools such as symbolic, computer algebra and graphical simulation packages and their contributions to learning. Presented in this paper also is the adaptation of hardware which was originally designed for recreation and entertainment to e-learning.

Keywords: e-learning, paradigm, hardware, tools, techniques

INTRODUCTION

Students and teachers in the world today are greatly affected by advances in the information and communication tools that they meet in the course of learning and impacting knowledge and there is sufficient interaction with these tools that we must learn to adapt to. It is therefore a necessary result that our mode of education must now take advantage of the current electronic alternatives. The reality of this fact is that there are a lot of new paradigms, which are both useful and meaningful. In the light of this it is imperative that we learn and know about these paradigms.

Technology is the system by which society provides its members with the things they need. The art of learning and impacting knowledge in itself is technology. The skilled manpower and knowledge produced by the combination of formal training, schooling and teaching are desirable products in society. Technology exists wherever man is present due to the fact that it aids man in his thriving and survival. Primitive technology is technology that is not driven by science and ICT is the present thing in human technological advancement and the driver of most other technologies in the modern world today.

Technology is increasingly being used both inside and outside the classroom. Embracing new technologies and finding optimal ways of harnessing their benefits is crucial to maximizing educational outcomes. However, in order to gain benefits from technologies it is important to have an understanding of the benefits of their usage, as well as ensuring that they are implemented in ideal ways. The main purpose of this paper is to assess the potential for using cloud computing in the field of education.

Defining Learning

The field of learning is full of many theories, with many dating back over 60 years. However, the majority of the currently popular theories are based upon studies that have been conducted during the past 20 years. On the whole, these theories can be categorized into five main types: humanist, behaviourist, cognitive, social learning, and critical reflection. Each orientation has its strengths and limitations, and there are some situations when one theory might be more applicable than another.

- Humanists hold the belief that people have unlimited potential for development, and that the objective of learning is to fulfil one's potential. Learning involves an active search for meaning, which is controlled by the learners who know their particular needs and goals. Educators should serve as facilitators of learning, by helping students learn the process of how to learn and teaching them to self-discover learning. Methods that exemplify this approach include self-directed learning, and experiential learning.

- Behaviourist's focus on skills development and behavioural change. Learning is seen as a change in overt, observable behaviour. The process of learning is seen as being controlled by stimuli in the external environment from educators and their curriculum, and not by the students themselves. The educator's role is to manage and control the learning environment by setting specific learning objectives and then monitoring the learner's progress. Behaviourism involves "Stimulus-Response" learning which is derived from Skinner's "Reinforcement Theory." Methods that exemplify the behaviourist educational methods include games and simulations, reinforcement and incentives, and instructional feedback [2].

- Cognitive and constructivist perspectives of learning emphasize the importance of understanding the mental processes involved in learning from the learner's perspective. According to these perspectives learning is seen as changes in the way in which the learner understands or organizes the elements of the environment, and changes in the behaviour of the learner are deemphasized. The purpose of learning is seen as the acquisition of knowledge, and the goal of educators is to create the optimal conditions for learning to occur. Methods include the use of metaphors, analogies and simile, chunking (presenting information in "chunks"), and concept mapping. Key figures in this field include Piaget, Bruner, and Bloom [2].
- Social learning theory integrates many of the ideas mentioned in the behavioural and cognitive views of learning. It believes that learning is a social process. Most of what people learn is through observations and interactions with other people in a social context. Focus is on the impact of people on people. In this theory the instructor is a model (demonstrator) or identifies and provides effective models, in addition to facilitate social interactions. Examples of educational methods: Demonstrations and trials, apprenticeships, mentoring, tutorials, peer partnerships, on-the-job training [2].
- Critical reflection theory focuses on critical reflection and capitalizing on learners' experience. In general, critical reflection involves the learner identifying and evaluating the assumptions, beliefs and values that underlie his or her thoughts, feelings or actions. This leads to a transformation in how one looks at the world. The instructor's role is that of critical analyst, stimulator of critical reflection, and challenger of assumptions. The emphasis is on learner and instructor equality. The educator is simultaneously teacher and learner. Examples of educational methods: Focus group inquiry, critical debate, imaging the future, reflective judgment, scenario building [2].

Defining e-learning

E-learning includes all forms of electronically supported learning and teaching. The information and communication systems, whether networked learning or not, serve as specific media to implement the learning process. This often involves both out-of-classroom and in-classroom educational experiences via technology, even as advances continue in regard to devices and curriculum. [12] E-learning is a fast and efficient way to spread knowledge to learners in different parts of the world. E-Learning uses the Internet or other digital content for learning and teaching activities, which takes full advantage of modern educational technology provided with a new mechanism of communication and resource rich learning environment to achieve a new way of learning". In addition, e-learning can significantly reduce the time learners spend on learning and it also allows them to access a broader spectrum of learning materials in accordance with their individual competences and situation without the limitations of time and space. . The main difference between an e-learning platform and a traditional classroom is the way in which instruction is transmitted. In an e-learning situation, the learning provider is separated from the learner by cyberspace, and has less visibility of the way the learner is interacting with the educational environment. The ability to adapt, realign, or change the environment is reduced due to this limited visibility. It also makes the educational content very important as the content is now the only differentiating factor between competing e-learning initiatives, assuming there is a level playing field in infrastructure for the provision of service over the internet [4].

E-Learning system

An e-Learning system is a popular technology for distance education. The e- Learning education system based on the web models conventional in-person education by providing equivalent virtual access to classes, contents, and other resources. It is also a social space where students and teacher can interact through threaded discussions or chat. There is a variety of benefits to use e-Learning system. Learner who has limitations of time and location can learn by themselves with the distant-learning system via Internet technology at a lower cost and higher quality in global scale. E-Learning system can be integrated with a physical learning environment which may be referred to as blended learning. It can take place synchronously or asynchronously. In synchronous systems, participants meet in "real time", and teachers conduct live classes in virtual classrooms. Students can communicate through a microphone, chat rights, or by writing on the board. In asynchronous learning, which is sometimes called "self-paced" learning, students are expected to complete lessons and assignments independently through the system. Asynchronous courses have deadlines just as synchronous courses do, but each student is learning at his own pace.

Virtual and Personal Learning Environments

Virtual Learning Environments (VLEs) are electronic platforms that can be used to provide and track e-learning courses and enhance face-to-face instruction with online components. Primarily they automate the

administration of learning by facilitating and then recording learner activity. VLEs have evolved quite differently for formal education and corporate training to meet different needs. The most common systems used in education are Blackboard and Moodle. VLEs are the dominant learning environments in higher education institutions. Known also as learning management systems (LMS) and course management systems (CMS), their main function is to simplify course management aimed for numerous learners. The content within VLE is developed by teachers, which are mainly experts of a special domain. VLEs provide an easy to use system for flexibly delivering learning materials, activities, and support to students across an institution. For the administrator, a VLE provides a set of tools which allows course content and students to be managed efficiently and provide a single point of integration with student record systems. For the tutor, a simple set of integrated tools allows the creation of learning content without specialist computer skills, whilst class administration tools facilitate communication between tutor and individual learners.

One major drawback of existing VLEs is that it is content-centric. Many instructors simply move all their teaching materials to the system. The materials are presented uniformly to all learners regardless of their background, learning styles and preferences [8]. Nowadays, we are seeing the trend in education that emphasis on learner-centric learning. A learner-centric learning places learner at its heart. Learners are expected to actively engage in the learning process to construct their own learning. Thus they have more responsibility for their learning. Instructors are still responsible for learners' learning, but they play the role of "facilitator" who guides the learning process instead of being the sole information provider. A learner-centric learning will give learners a deeper and richer learning experience, as there is greater participation and involvement in the learning [13].

In the last few years a new wave of web technologies such as blogs, wikis, and social software, known as Web 2.0, has become a major technology that supports content publishing over the Internet. Web 2.0 allows people to create, publish, exchange, share, and cooperate on information in a new way of communication and collaboration. Applying Web 2.0 technologies to e-learning can enhance interactive communication and collaboration among participants and learners who either possess related learning resources, or can help to discover and obtain the resources, or are willing to exchange and share the resources with others in the Web-based learning. In Web 2.0, learners can read and write to the Web, in which learners become the consumers and producers of learning resources. Thus, Web 2.0 provides a learning environment have the potential to fundamentally change the nature of learning and teaching, through the creation of learner controlled learning web. This kind of environment is named Personal Learning Environment (PLE).

Adoption of PLEs as the platform for e-learning is motivated by several reasons. The most important is that PLEs help learners control and manage their own learning. This includes providing support for learners to set their own learning goals, manage their content and communicate with others in the process of learning, and thereby achieve their learning. A PLE also permits learners to join into groups and provides a suitable environment to practice social skills. Furthermore, PLEs can provide support for lifelong learning that is mainly informal and occurs over the life of the learner. Nevertheless, it has not been proven yet if PLEs can enable the growth of reflective skills, and thus enable the growth of self-directed learner [9].

21st Century Learners

Students today are often referred to as 21st Century learners, primarily because of the ubiquitous access they have to technology. What sets them apart from other generations is the way they process information and choose to participate in the educational experience. Dr. Sarah Elaine Eaton, an educational leader, researcher, author and professional speaker, has identified 21 Characteristics of 21st Century Learners. [13] Some interesting characteristics are considered as follows:

- Often have higher levels of digital literacy than their parents or teachers. They do not know a world without computers.
- Demand the freedom to show their wild creativity. 21st century learners balk at rote learning and memorizing. They will do it if you make them, but be prepared to let them loose to be creative, too.
- Want to connect with others in real time on their own terms. They want their social media, their phones and their mobile technology. They want to be connected. All the time. In a way that makes sense to them.
- Expect inter-disciplinarily. It is we, the older generation, who organize topics into "subjects". The 21st century learner understands that subjects are inherently interconnected.

Some educators seek out the ideals of a 21st century learning environment constantly, while others prefer that they lose the phase altogether, insisting that learning has not changed, and good learning looks the same whether it is the 12th or 21st century. In this view, Teach Thought developed 9 Characteristics Of 21st Century Learning that considers the potential of social media platforms against its apparent divergence from academic learning.

Higher education and life-long human resource development are urgent issues to support the sustainable development of a global society. However, the traditional style of face-to-face education is not able to meet the demands of the society because of the limitations in location, time and cost. An Internet-based e-Learning system should be utilized to support education activities according to the social requirements [13].

What Is Cloud Computing?

The National Institute of Standards and Technology (NIST) defines cloud computing as follows: Cloud computing is a model for enabling convenient, on-demand network access to a shared pool of configurable computing resources (e.g., networks, servers, storage, applications, and services) that can be rapidly provisioned and released with minimal management effort or service provider interaction.

There are two basic types of cloud infrastructures: internal and external. In an internal cloud, servers, software resources, and IT expertise are used inside the school system to build a scalable infrastructure that meets cloud computing requirements. In an external cloud, service providers sell on-demand, shared services to a school. IT support, services, and expertise are included in the package; the school needs to run only the provided applications and services. Cloud computing is a calculation of providing leasing services to users, the user can use a simple terminal to access powerful computing capabilities, regardless of the complexity of the background. To meet the users' needs, which the back-end cloud concerns care is the number of machines required to achieve cooperation. Now Google, Amazon and other companies have built the cloud platform to provided services for their clients, include hundreds of back-end machines at least. It is obvious that cloud platform back-end is a large distributed system, rather than a single machine which user interface displayed. Cloud computing turn the hardware resources into virtual resources with virtual machine monitor, and manage hardware resources with virtual hardware.

E-Learning paradigms:

Podcasting

Podcasting is actually the downloading of audio, video and acrobat files over the web to an ipod, MP3 player, mobile phone or computer. This is making serious impact in education because it offers public access to lectures, school events and performances. Once the hardware is in place, podcasts can deliver lessons as audio or video files for those who cannot or will not attend in the normal way. They can also deliver the basics of a lesson, background of a topic, homework assignments etc for free up to a teacher [3]. The technology also provides the details and facts that the pupils can refer back to during revision. If the class itself is producing the podcast, this instantly creates the need for teamwork, technical literacy and planning, as well as the ability to research and write up the podcast topic itself.

Simulation

Simulation can actually be used to emulate natural phenomena and recently, simulations are being used as instructional tools. Effective instructional simulations contain the following five elements: (1) one or more dynamic models, (2) interactions resulting in state changes, (3) non-linear logic (4) help structures to augment instruction

Simulation can be an extremely useful aid. You can choose what to focus on, build up complexity and control the environment. You can also introduce components that are purely virtual. The implication of this is that we are having simulations that are as close to laboratory experience as possible [3].

Open Sourcing

There are several whole libraries on the web. This helps to avoid the litigious issues of copyrights by beginning from materials that are in the public domain. The Wikipedia and the wiki system have introduced a user extensible system where users can actually add to the library while attempting to put educational materials spanning a wide variety of interests. This is "Open Sourcing" of on-line libraries and it is free and available to anyone with internet access. [3]

A New e-learning paradigm:

CLOUD BASED E-LEARNING

In Cloud computing technology based e-Learning system all the academic institutions of a Country or State can be connected globally and they can share the resources and e-contents for e-learning process. To connect the academic institutes for e-Learning system we can think e-Cloud model. The proposed e-Cloud provides the opportunity of flexibility and adaptability to use the computing resources on-demand without physical purchasing or installation at user site. Contrary to having only one service provider in present e-Learning models where the software has to install on each system, different providers use different interfaces to their computing

resources utilizing varied architectures and implementation technologies for customers (University or Institutes) [10].

The massive proliferation of affordable computers, Internet broadband connectivity and rich education content has created a global phenomenon in which information and communication technology (ICT) is being used to transform education. Therefore, there is a need to redesign the educational system to meet the needs better. The advent of computers with sophisticated software has made it possible to solve many complex problems very fast and at a lower cost. This paper introduces the characteristics of the current E-Learning and then analyses the concept of cloud computing and describes the architecture of cloud computing platform by combining the features of E-Learning.

HOW IT WORKS

Cloud based e-learning is the sub division of cloud computing on educational field for e-learning systems. It is the future for e-learning technology and its infrastructure. Cloud based e-learning has all the provisions like hardware and software resources to enhance the traditional e-learning infrastructure. Once the educational materials for e-learning systems are virtualized in cloud servers these materials are available for use to students and other educational businesses in the form of rent base from cloud vendors. Cloud based e-learning architecture is explained in the following figure[9]:

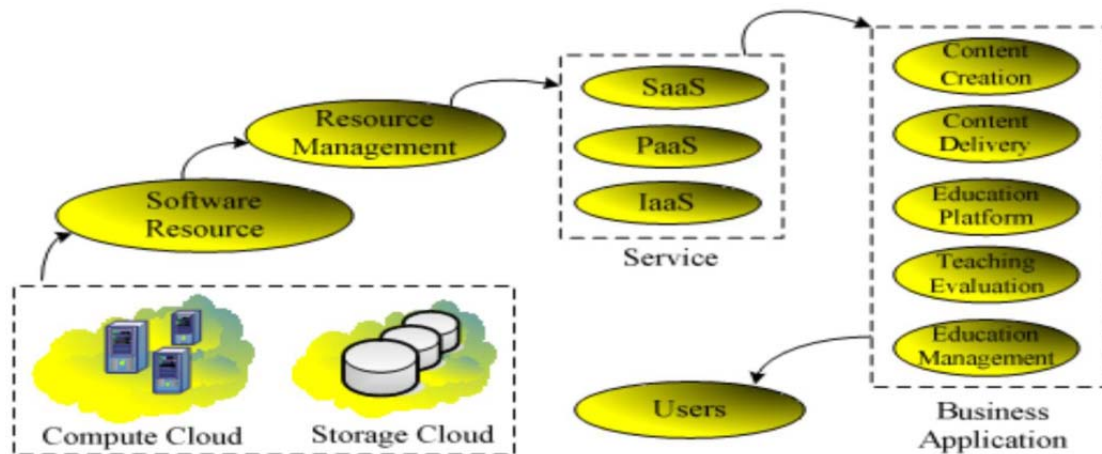

Architecture of e-learning cloud

Cloud based e-learning architecture is mainly divided into five layers called hardware resource layer, software resource layer, resource management layer, server layer and business application layer. It also supports multiple client platforms both inside and outside the school infrastructure

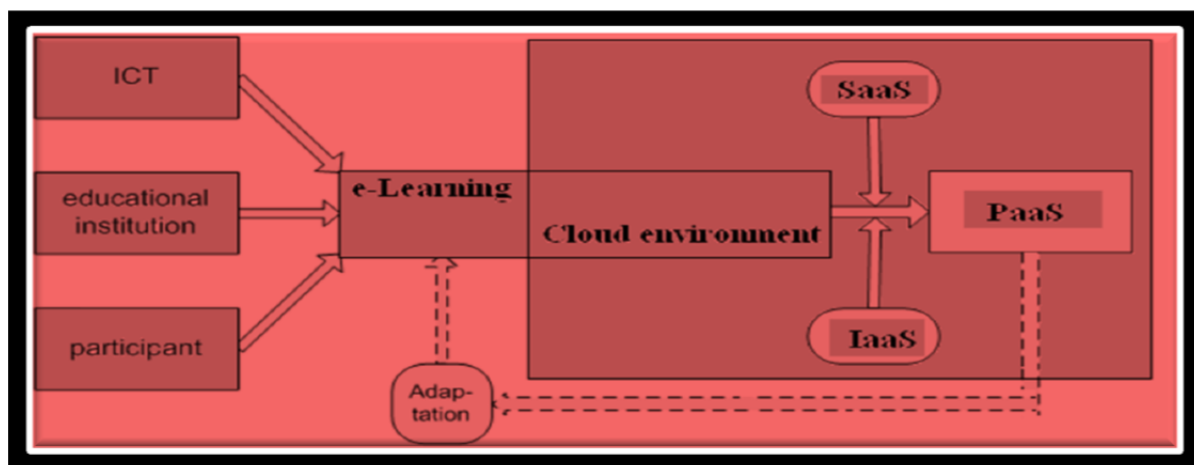

E-Learning system with cloud

FRAMEWORK FOR CLOUD BASED E-LEARNING:

A. The base layer of e-learning cloud

The base layer of e-learning cloud shares IT infrastructure resources and connects the huge system pool together to provide services. Cloud Computing allows the hardware layer to run more like the internet, to make the hardware resources shared and accessed as data resources in secure and scalable way. Virtualization technology separates the physical hardware from operating system, which on one hand can make computing and storage capacity of the existing server into smaller size and re-integration, to improve the utilization and flexibility of IT resource; on the other hand can provide a common interface for large-scale cloud computing integration that enables the publication of calculation. The base layer can provide the basic hardware resources for the platform layer, and the users can also make use of it as the same as using a local device to use.

B. The platform layer of e-Learning cloud With the support of the powerful hardware, platform layer carries out the tasks of data storage, computing and software development, and it can even achieve the tasks of completion of the original mass data storage, business intelligence processing and so on which have been difficult to complete. Users can choose the devices and the number of devices according to the complexity of dealing with the content. Virtualization technology enables the platform to show a strong level of flexibility [1].

The more recent trend in the E-Learning sector is screen casting. There are many screen casting tools available but the latest buzz is all about the web based screen casting tools which allow the users to create screencasts directly from their browser and make the video available online so that the viewers can stream the video directly [1]. The advantage of such tools is that it gives the presenter the ability to show his ideas and flow of thoughts rather than simply explain them, which may be more confusing when delivered via simple text instructions. With the combination of video and audio, the expert can mimic the one on one experience of the classroom and deliver clear, complete instructions. From the learner's point of view this provides the ability to pause and rewind and gives the learner the advantage of moving at their own pace, something a classroom cannot always offer.

BENEFITS

Provides a flexible, scalable, cost effective model that does not force the institute or university to use out-of-date infrastructure or software application.

Offers the flexibility to meet rapidly changing software requirements for today's and tomorrow's teachers and students.

Allows software standardization, a shared pool of applications for use in an e-learning system for school, college or university, and easier maintenance through centralized licensing and updates.

Enables rapid development and deployment of complex solutions without the need for in-house expertise

Can eliminate the upfront financial burden of deploying new technologies through a pay-as-you-go model.

CONCLUSION

The current trends in the delivery of e-learning have been presented and it is clear that we must provide facilities that will help us benefit fully from the useful materials that are freely available on the internet. We also verified that cloud computing technologies can be exploited to build the next generation of e-learning systems to provide smart formal and informal learning. This set of technologies has clear potential to distribute applications across a wider set of devices in addition to making educational services to be instant, intelligent, multi-sensory, seamless and social and greatly reducing the overall cost of computing.

REFERENCES

- [1] Deepanshu Madan et al Volume 2, issue 2, February 2012 www.ijarcse.com, 2012, IJARCSSE
- [2] Deshler, J.D., E. Kiely, *Facilitating Adult Learning: Sourcebook & Leader's Guide*. 1995: Cornell University", Cornell Instructional Materials Service.
- [3] Fakinlede O.A. Energy Commission of Nigeria, Abuja. *E-Learning: Tools, Protocols and Techniques*, paper presented at Capacity Building Workshop by ETF, Zaria 2006.
- [4] Faten Karim, Dr. Robert Goodwin, *Using Cloud Computing in E-learning Systems International Journal of Advanced Research in Computer Science & Technology (IJARCSST) Vol. 1 Issue 1 Oct-Dec 2013*
- [5] Guoli, Z., L. Wanjun, "The applied research of cloud computing platform architecture in the E-Learning area", In *Computer and Automation Engineering (ICCAE)*, 2010 The 2nd International Conference on. 2010. IEEE . [6]
- [6] Hamid, A.A., "E-learning: is it the "e" or the learning that matters? The Internet and Higher Education", 2001. 4(3), pp. 311-316.
- [7] Harmelen M., "Design trajectories: four experiments in PLE implementation," *Interactive Learning Environments*, vol. 16: Issue 1, pp. 35 - 46, 2008.
- [8] Kamal Dhull, *International Journal of Informative and Futuristic Research (ijifr)* Volume 1 Issue 2, October 2013 Research Area: Cloud Computing, Page No. : 75-83 Cloud computing based e-learning system to provide easy access of e-contents and web resources for educational institutes in developing countries,
- [9] Liu, C.-H. , "The comparison of learning effectiveness between traditional face-to-face learning and e-learning among goal-oriented users", in *Digital Content, Multimedia Technology and its Applications (IDC)*, 2010 6th International Conference on. 2010. IEEE.
- [10] M. Oztok and C. Brett, "Social presence and online learning: A review of research," *The Journal of Distance Education*, vol.26, no.2, 2012.], [J. Percival and B. Muirhead, "Prioritizing the implementation of e-learning tools to enhance the post-secondary learning environment," *The Journal of Distance Education*, vol.23, no.1, pp.89–106, 2009.
- [11] Mohammed Al-Zoube , Princess Sumaya University for Technology, Jordan *International Arab Journal of e-Technology*, Vol. 1, No. 2, June 2009
- [12] S.E. Eaton, "21 characteristics of 21st century learners," *Literacy, Languages and Leadership*, <http://drsaraheaton.wordpress.com/2011/12/07/21st-century-learners/>, December 2011..
- [13] Utpal Jyoti Bora, Majidul Ahmed, *E-Learning using Cloud Computing, International Journal of Science and Modern Engineering (IJISME) ISSN: 2319-6386, Volume-1, Issue-2, January 2013.*

POTENTIAL USE OF DIGITAL TECHNOLOGIES IN MATHEMATICAL MODELING THE FIRST STEPS OF RESEARCH

Morgana SCHELLER

IFC – Câmpus Rio do Sul/PUCRS,
morganascheller@yahoo.com.br

Maria Salett BIEMBENGUT

PUCRS,
maria.salett@puers.br

ABSTRACT: This article presents and analyzes one practice of scientific initiation developed from the use of modeling and digital technologies on basic research projects as a way to stimulate the art of research. The empirical study was conducted in a public agricultural institution in southern Brazil, in which high school students develop research papers at school, during one year. Data were collected through observation of the students activities, field reports, articles and the socialization material. They were analyzed using content analysis of Bardin (1979). Results points that the use of digital technologies enhances the work of mathematical modeling and, both articulated with discussions related to the reality of those involved, promote students: motivation in learning and research; autonomy; reflexion and knowledge to the expression of their own actions and even math itself.

Keywords: Modeling, digital technology, project, scientific initiation.

INTRODUCTION

School research should occupy increasingly larger space in educational institutions, in order to develop skills and abilities that enable students to aim educational goals of different levels, both conceptual, as procedural or behavioral. In mathematics teaching, the subject must extrapolate the instrumental character, posing itself as science research with characteristics of investigation, whose role is to integrate with the other sciences. Thus, in the basic education we seek to develop "strategy of learning to learn, how to think, understand the reality globally, evaluate social and productive processes, discuss and perform quality citizenship and production" (DEMO, 2009, p. 85).

Therefore the teaching of mathematics should prioritize the construction of knowledge; knowledge gained through investigative, constructive and non-instructional processes. A student, much more than mastering techniques and strategies of calculus, needs to develop the initiative and creative sense to learn to adapt it to different contexts, using them appropriately in many situations (BRAZIL, 2008). Because "we are, as bodies that adapt themselves and solve problems, motivated to respond to our environment and achieving goals and objectives." (George, 1973, p. 29).

Learning math and in parallel learning to research with the help of digital technology, software, computers, internet, makes that they acquire natural importance as resources that permit an approach of problems which data require selection and analysis skills. Accordingly, it is necessary to provide students opportunities to develop skills related to representation, understanding, communication and research, as well as the sociocultural context, regardless of the subject or context. The school can help stimulate the student to research, both within the classroom and beyond. As endorses Demo (1996) it may be an opportunity to begin the first steps in the art of research, awakening the student's curiosity, autonomy in seeking information and, finally, the expression of ideas.

In this way, teachers and students can share tasks traversing paths that culminate in the development of skills and learning of scientific concepts, through the development of research projects. As mathematical modeling has an approach related with projects, these have received significant contributions in the last years, of digital technologies as a way of support. Many practical research in this direction have already been made. We mention the research of Araujo (2002), Diniz (2007), Borba and Malheiros (2007), Franchi (2007), Malheiros (2008) and Borba and Villareal (2005), whose research involves modeling and ICT, with the objective of understand and

analyze modeling practices and digital technologies in the classroom, in the form of activities or projects developed in different levels of education for the purpose of explore mathematical content, i.e., learn math and do not necessarily develop research-related skills.

Based on recent studies involving modeling and digital technologies, and with the premise that students become more interested in learning by conducting research, the study aims to present and analyze a practice of Undergraduate Research in Secondary Agricultural School looking for potentials on the use of digital technologies in modeling. Therefore, hereafter is a theoretical outline used to contextualize the study, followed by the methodological aspects that are the guidance, the reasoning, data, the manifest and latent knowledge of the study.

THE THEORETICAL CONTRIBUTION OF THE RESEARCH: FROM MODELING TO THE DIGITAL TECHNOLOGIES

Biembengut (2004) sees modeling as a set of procedures to make a model which process may be used in any area of knowledge. For Bassanezi (2006), either as a teaching strategy or scientific method, modeling is a process that involves theory and practice, leading researchers to interact and understand the reality that is inserted in the investigation, and may have as consequence the action on it aiming transformations.

In the context of education, Biembengut (2004) defines modeling as a research method, particularly used in the Sciences. He emphasizes that modeling procedures are essentially the same presented in stages of scientific research; so, defends as a method in education. The purpose is to encourage and engage students to do research, learning math at the same time, which can be used at any stage of education. Therefore, Biembengut (2013) groups into three procedures of modeling:

- First stage: Perception and seizure - at this stage occurs the recognition and delineation of the problem; and familiarity with the subject to be modeled, consisting of a subsequently theoretical framework.
- 2nd stage: Comprehension and explanation - after performing interaction with the subject, the formulation of the problem is made, questions are elaborated and hypothesis are pointed up; subsequently takes place the formulation of the model.
- 3rd stage: Significance and expression – made the resolution of the problem from the model and interpretation of the solution found. Consists of a review of the model looking for verify whether the model is valid or not and the expression of the process and the outcome.

In recent decades, as modeling, digital technologies also came up when the objective is the pursuit of knowledge and interpretation of a phenomenon, with them there are more and better ways to learn. Lévy (1993) points out that computer media creates conditions for qualitative changes in education, quality regarding the one arises from the collective, with the formation of networks and intelligence seen as a process in which various knowledges are included. To Papert (1985, P. 2), to think about the use of computers coupled with the use of projects, just realize that this adds quality learning, if those implementing the project, is in possession of their interests and desires. Ponder that "[...] technology is not the solution, it is only one instrument." Soon, school modeling practices can have it as a tool to enhance research and education, as advocated by Brazil (2008).

For Moran, Masetto and BEhrens (2000), the *internet* facilitates students' motivation, because of the novelty and the endless research possibilities it offers. It helps to develop intuition, mental flexibility and adaptation to different rhythms. In the context of modeling, Blum and Niss (1991) argue that ICTs used in modeling work not only in facilitating problem solving as are necessary to validate the mathematical model. Borba and Penteadó (2001) believe that informatics facilitates the visualization of models, enables the emergence of conjectures and may lead to discoveries. They emphasize that computers reorganize the thoughts and contributes to change the traditional teaching practices. Araújo (2002) confirms these information showing that the interaction between students and ICT enables new strands of research, well as the interaction of modeling and technology enables the exploration of problem situations in which it participates actively in the process.

METHODS AND PROCEDURES

Regarding the empirical space, the study was conducted at the Federal Institute of Santa Catarina - Campus Rio South, public institution of integrated technician course located in southern Brazil, during the development of 4 research projects in which students have initiated the art of research. Developed at school environment, seven students from 2nd and 3rd grade of Technical Education, with 16 and 17 years old, held their projects integrating the areas of agriculture, mathematics and informatics. These projects have utilized modeling as a search method for studying the phenomena / problems existing in other areas of knowledge related to daily life of their course, with digital technologies a resource for the development of research.

In this context the research is inserted, characterized with qualitative case study (Yin, 2001). Empirical data were derived from observation, field diaries, articles and socialization material, materials produced during the project development. Unstructured observations occurred for approximately one year (2011-2013) at weekly meetings of 1.5 to 2 hours and were being recorded in a logbook. They were conducted to describe and understand what was happening in certain situations. Also, copies of written materials produced by students in the course of research activity were utilized, such as work files, the final article, *poster* and video. For the data analysis procedures of Content Analysis (Bardin, 1979) were used.

RESULTS AND FINDINGS

The collected data allowed the identification of three categories in relation to the potential of digital technologies and modeling at the first steps in the art of basic research in high school. They flow with more or less emphasis according to the characteristics of each group of students in the developed projects. These categories are seen on the speeches of the students, along with material that they have produced. In the text that follows these three categories are implied, which are identified as: the use of technical standards in the writing of research; understanding of what and how to research; cognitive development (descriptive skills, analytical, critical and creative).

About perception and apprehension

Related to agricultural area, the subjects of the research were about growing heifers for dairy purposes, study of egg production of laying hens, chicken and pigs growing and lactating Holstein cow curve. In an initial stage, students have look for realizing and getting a larger number of information about the topic in order to delimit a problem situation for each project. Biembengut (2013) points out that this phase is important, because in order to understand a problem situation, a phenomenon or a theme / topic of interest, one must understand its context and get the greatest number of information and data available in first instance, and thus recognize and become familiar with the topic / subject.

In this step, students have explored the existing knowledge in the literature, with professionals from zootechnical area, as well as part of academic material available on the worldwide web pages, all with reference to the subject. Such information obtained were arranged in the form of files, records of readings, data, videos, magazine articles, and other forms. The internet, computer and software such as *Excel* and *Grafhmática* resources were further explored by students. This confirms what is described by Borba and Penteado (2001), that students use technology from the beginning of their research. "- When we choose *Google* search, there are thousands of search options for us to know more about the topic. Now we need to filter and see what really matters. It is not only open the first and the search is over. ", Considered the student B.

Stands out beyond the modification of the concept of common research in basic education by students, that in the transition from the 1st to the 2nd phase of modeling, they have already opted for recording data using *Excel*, leaving aside simpler resources like calculators or non digital spreadsheets. Students have already incorporated technology into their studies, confirming the birth of information in the digital age. Biembengut (2013) highlights that the phase of perception and apprehension (recognition and familiarity of the theme) are not disjoint. As some data are perceived, they collect them, and this allows the perception of other data, other information, and so on in a cyclic process, however, increased. This modeling step may be ended with a text compiled and arranged and organized in data tables, such as Table 1.

Table 1. Chicken eggs industrial classification according to its weight (grams)

Identification	Rating
Jumbo	Greater than 66
Extra	60-65
Big	55-60
Average	50-55
Small	45-50
Industrial	Less than 45

Understanding and explanation

In the second stage of modeling, there is a dialogue between the counselor and the student C asked, which developed the project on growth of calves:

- "Does the height and chest girth of the calves have proportional growth? Are they constant? - "What this question can infer in your study?" The teacher asked. - "You mean the two do not grow proportionally, it will

have its disproportionate body and this may impair milk production" Student C. Students seek to understand a problem in every part of it, seeking a way to make it explicit. The question from the student demonstrates that they start not to accept reality anyway, questioning it. They do not consider as something perfect, correct.

In the episode above, the student makes use of mental mechanisms to take advantage and upgrade his/her perception on the considerations of the problem. This is the way people expand their cognitive ability. Vygotsky (1989) calls inner speech the process in which the student enters the symbolic system in his psychological apparatus, with the support of the language. And a research favors this type of development to be active, interactive and constructive individual in an environment conducive to interaction.

Cognitive skills enabled students design a model that would allow not only the resolution of the particular issue, but also serve to make predictions or allow a (re) creation. They used the previous knowledge for a model. Result can translate what, in high school, can be constructed by students.

The algebraic model $A(p) = p \cdot 0.55 + 32.28$ was one of the obtained with the aid of Excel, when investigating the relationship between height and heart girth present in the growth of calves. In this model, like all functional model, are incorporating the particularities of the analysed phenomenon (Bassanezi, 2006). In the case of explicit algebraic model, the "A (p)" is the height (cm) and "p" the heart girth (cm) along the calves growth, obtained through what Levy (1993) calls simulation possibilities. Thus the second stage is effective to understand the data and explicitation of the model. And this requires the modeler student creativity, critical, analytical power, persistence, among others.

Of meaning and expression

The model validation, in all projects, took advantage of the use of Excel and it consists of the resumption of empirical data arising from experiments and / or literature by applying the model. It was noticed at this stage that on studying and solving a problem using the computer, the student describes the problem to be solved, the computer performs a task through software or a programming language, and allows the student to interact with the program, thinking, reflecting and making decisions about the activity. This is the constructionist paradigm defended by Valente (1993).

- "Wow, the graphical display of the model obtained by empirical data and the model designed by the company that provides the animals is very close visually. Now we need to check whether this difference is significant"? Student S on the express graphical model in Figure 1.

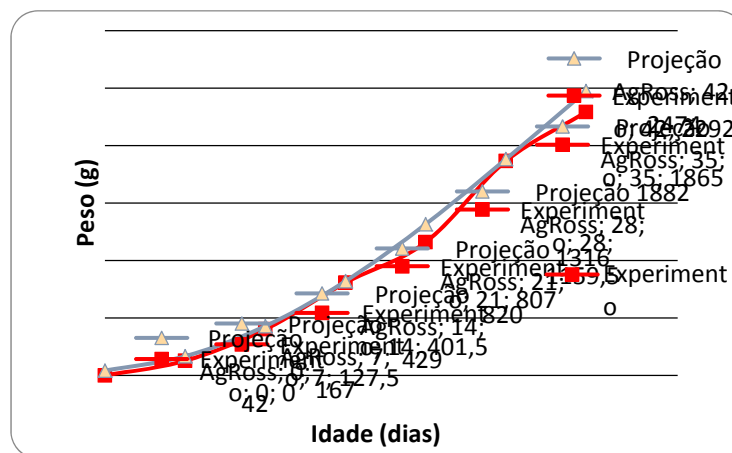

Figure 1. Comparison of representative models of the growth of broiler chickens based on empirical data and engineered for animals.

In this third stage of modeling, Biembengut (2013) discusses that it is the stage of expression and this implies to evaluate and verify the validity of the model, and thus express it. Students perform evaluation of the models taking into account aspects presented in the literature, which data were obtained empirically and projected by the model. "- Damn life, now I'm really seeing what it means to do research, it is quite cool teacher!" Student K illustrates about the phase of modeling and representing what the research means for him/her, when handling the Excel spreadsheet aiming at validating the model.

The communication of the model is one way to test it and complete the modeling process. As a final step of expression, lactation curves Project students developed na projection and control instrument of these curves in an Excel spreadsheet, preparing a video for better explanation of the project and the instrument to the general

public (Figure 2). This part went beyond the initial purpose of the project and demonstrates that motivation and interest drive the student to build ways to solve his/her problems. "The ownership of a response to a stimulus or stimulus complex should depend on the motivation (George, 1973, p. 28).

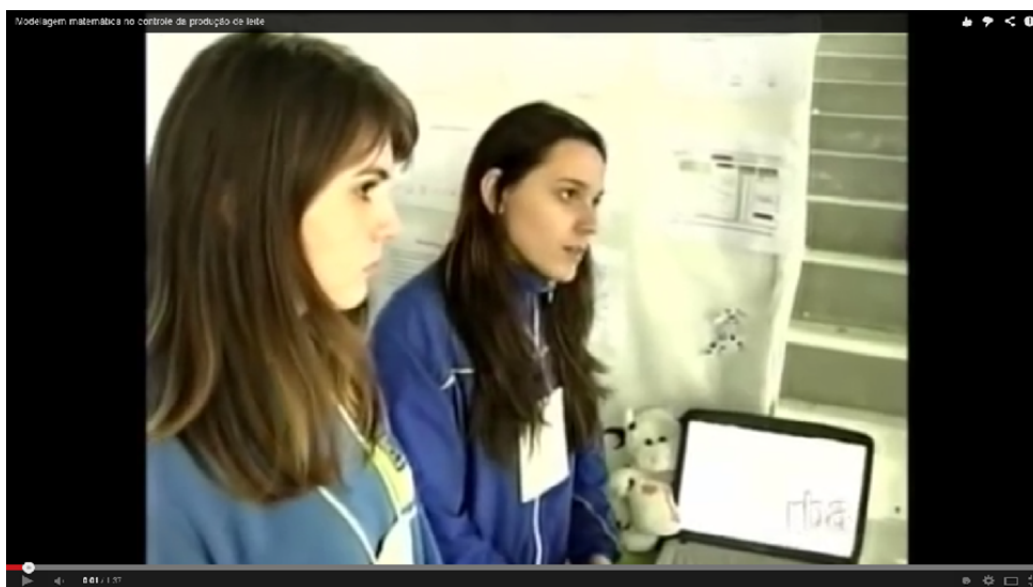

Figure 2. Outline of study instrument developed by students completing the modeling process

All projects were released to the community, both orally and in writing. For that, students have developed an abstract, article and poster, explaining that socialization are crucial when doing research, when it takes the first steps in the art of research. "- It is very good to present what we have done, it gives a pride, especially when there are people who want to hear us. It is rewarding, and our public commitment to take our studies to milk producers and others in the community" student M expressing his views about the research communication. It was just possible at any level of education "because the student is given the opportunity to study the problem situations through research, developing their interest and sharpening their critical thinking" (Biembengut, 2004, p. 23).

CONCLUSION

All the navigation through this study so far allows some relevant analysis of the practice of scientific research: aim of this study. We emphasize modeling as a research method in which students extend their understanding and build knowledge. Knowledge not only conceptually, but also procedural and behavioral related to mathematical and technological domain, techniques and procedures of the research. It is important to consider the use of technology as a resource to support the modeling, present in all stages of modeling, enabling students to complete inferences about: the research theme and your interaction with it, the model in their tabular representations, graphical and algebraic, significance and the model's expression and communication project for validation.

It is emphasized in the study, three potential use of digital technologies and modeling in the first steps of research of high school students: the first refers to the use of technical indicatives on writing results of the projects of these students to develop their final articles, abstracts and posters. Stand out the tables, charts, quotes, references, among others. These are aspects that are not customarily present in works produced by students at this level of education. Another highlight is to the "new" conception of what is and how to study, since most students conceive research as a copy of what a particular author claims related to a theme, taking it as his/her. Finally, we highlight the cognitive development of students in terms of descriptive, creative, analytical and critical skills. It was noticed in describing the theme, sketch and compare the data, choose strategies for obtaining the model, analyze the feasibility of the model, modify the assumptions for model improvement, communicate their results, worrying about the social commitment to socialize their work, among others.

Digital technology and the modeling provided to students social posture while studying a theme. This occurs not only by studying, but for considering it essential to extrapolate the school boundaries with socialization and dissemination of the instrument to milk producers, broiler breeders and laying, of calves and the school community. This way, contributed to the formation of citizenship, to awaken new views, whether on the situation investigated, or on the political and social reality that surrounded them in the environment that was motivating for them. This presentation and analysis ends here highlighting the statement Papert (1985), expressing that to educate is to create situations for learners to engage in activities that will fuel constructive

process to think and learn. A process in which active subjects in the construction of knowledge, authors subjects, dive in art research.

REFERENCES

- ARAÚJO, J. L. (2002). *Cálculo, Tecnologias e Modelagem Matemática*: as discussões dos alunos. Rio Claro: UNESP, Tese de Doutorado.
- BARDIN, L. (1979). *Análise de conteúdo*. Lisboa: Edições 70, 1979.
- BASSANEZZI, R. C. (2006). *Ensino-aprendizagem com modelagem matemática*. 3. ed. São Paulo: Contexto.
- BIEMBENGUT, M. S. (2004). *Modelagem matemática & Implicações no Ensino e na Aprendizagem de Matemática*. 2. ed. Blumenau: Edifurb.
- BIEMBENGUT, M. S. (2013). *Modelagem no Ensino Fundamental*. 2013. (no prelo pela Editora da FURB)
- BLUM, W. & NISS, M. (1991). *Applied Mathematical Problem Solving, Modelling, Applications, and Links to Other Subjects – State, Trends and Issues in Mathematics Instruction*. Educational Studies in Mathematics, Dordrecht, v. 22, n. 1, p. 37-68, feb.
- BORBA, M. C. & MALHEIROS, A. P. S. (2007). *Internet e Modelagem*: desenvolvimento de projetos e o CMV. In: Barbosa, J.; CALDEIRA, A.; ARAÚJO, J. L. *Modelagem Matemática na Educação Matemática*: pesquisas educacionais. Recife: Sbem, 3, 195-211.
- BORBA, M. C. & VILLARREAL, M. E. (2005). *Humans-with-Media and Reorganization of Mathematical Thinking*: Information and Communication Technologies, Modeling, Visualization and Experimentation. New York: Springer Science+Business Media, Inc.
- BORBA, M. C. & PENTEADO, M. G. (2001). *Informática e Educação Matemática*. Belo horizonte: Autêntica.
- BRAZIL. *Orientações curriculares para o ensino médio*: ciências da natureza, matemática e suas tecnologias. Brasília: MEC, Secretaria de Educação Básica, 2008, v.2.
- DEMO, P. (1996). *Educar pela pesquisa*. Campinas: Autores Associados.
- _____. (2009). *Desafios Modernos da Educação*. 15. ed. Petrópolis: Vozes.
- DINIZ, L. N. (2007). *O Papel das Tecnologias da Informação e Comunicação nos Projetos de Modelagem Matemática*. Rio Claro: UNESP. Dissertação de Mestrado.
- FRANCHI, R. H. O. L. (2007). Ambientes de aprendizagem fundamentados na modelagem matemática e na informática como possibilidades para a Educação matemática. In: Barbosa, J.; CALDEIRA, A.; ARAÚJO, J. L. *Modelagem Matemática na Educação Matemática*: pesquisas educacionais. Recife: Sbem, 3, 177-194.
- GEORGE, F. (1973). *Modelos de Pensamentos*. Trad. Mário Guerreiro. Petrópolis: Vozes.
- LÉVY, P. (1993). *As tecnologias da Inteligência*: O futuro do pensamento na era da informática. Rio de janeiro: Editora 34. Trad. Carlos Irineu da Costa.
- MALHEIROS, A. P. S. (2008). *Educação Matemática on-line*: a elaboração de projetos de modelagem matemática. Rio Claro: UNESP. Tese de Doutorado.
- MORAN, J. M.; MASETTO, M. T.; BEHRENS, M. A. (2000). *Novas tecnologias e mediação pedagógica*. 12. ed. Campinas: Papirus,
- PAPERT, S. (1985). *Logo*: computadores e Educação. São Paulo: Editora Brasiliense.
- YIN, R. K. (2001). *Estudo de caso*: planejamento e métodos. Trad. Daniel Grassi. 2. ed. Porto Alegre: Bookmann.
- VALENTE, J. A. (1993). *Computadores e conhecimento*: repensando a educação. Campinas: Gráfica Central da UNICAMP, 1-23.

EFFECT OF GENDER-RELATED DIFFERENCES IN ACADEMIC ACHIEVEMENT AND RETENTION OF SENIOR SECONDARY SCHOOL STUDENTS TAUGHT GEOMETRY USING PROBLEM SOLVING APPROACH

Abbas Muhammad GUMEL

DEPARTMENT OF MATHEMATICS;

JIGAWA STATE COLLEGE OF EDUCATION, GUMEL, NIGERIA

basgumel1919@yahoo.com

Habu GALADIMA

DEPARTMENT OF PRIMARY EDUCATION STUDIES

JIGAWA STATE COLLEGE OF EDUCATION GUMEL, NIGERIA

habugaladima@gmail.com

ABSTRACT: This study investigates the effect of gender related differences on Geometry Achievement and retention of senior secondary school students. A pretest-posttest experimental control group research design was used. A total of 70 SS3 students were selected from about 9,540 students of Jigawa state using stratified random sampling techniques. Both male and female group were treated using problem solving approach. The instruments used for data collection were Researchers Made Test (RMT), Geometry Achievement Test (GAT) and Geometry Retention-Test (GRT). Data collected were analyzed using t-test statistic. Finding statistically showed the existence of significant difference between male and female students' performance in Geometry Achievement Test, while there is no significant difference in male and female performance in Geometry Retention-Test. Based on the findings, Mathematics Teachers are encouraged to use problem solving approach (polya model) in teaching Mathematics.

Key Words: Gender Related Difference, Achievement, Retention, Geometry, Secondary school

INTRODUCTION

The role of Mathematics in the scientific, technological and economic development of any nation can never be overemphasized. It is based on this notion that Adetula (1988) identified Mathematics as the key to National development. This view is also supported by Ibrahim (1998) who states that if any nation wants to achieve scientific and technological development, Mathematics should be properly taught to prepare the minds of students toward scientific and technological reasoning.

However, the perpetual global Scientific and Technological development and extraordinary world population growth rate continue to throw a challenge to Mathematics educators and researchers to come up with most effective and suitable method of teaching Mathematics at all levels of education, so that, Millennium Development Goals of Education For All (EFA) and promoting gender parity could be achieved (MDGs 1990). In Nigeria, 2006 census figures indicated that females outnumbered males in the country (NPC, 2006). As such, all concerted efforts have to be made to encourage female to acquire more knowledge as their male counterparts. It is for this view that Fennema in Adetula (1988) stresses the need to continue research that documents the status of gender differences as they exist in Mathematics education. In response to this call, attempts were made by various scholars to justify stereotype about female inferiority or otherwise in learning of Mathematics.

Literature in and outside Nigeria shows that male students performed significantly better than their female counterpart in secondary school Mathematics (Abbas, 2008 ; Batista, 1990 and Cassey, Nuttail & Pezaris, 2001). Even though, Adeleke (2007) argue that, the difference in performance occurred only in higher order knowledge. In the same course Manger (1996) investigated the relationship between gender and mathematical achievement with Norwegian 3rd graders in Numeracy, Fraction and geometry. He found that male score more than female even though the difference was small. On the other hand Mulli (1998) and Awang & Noor (nd)

found that females significantly scored higher than males in the overall average achievement in Mathematics. These parallel results indicated that, the issue of gender factor on cognitive achievement in Mathematics seems inconclusive.

Lassa (1986); Kajuru (1995) and West African Chief Examiners report (WAEC, 2010) have separately claimed that the performance of students in geometry is lower than in other aspect of Mathematics. Scholars have attributed this difficulty in learning geometry to various factors. Kajuru (1995) explain that, the reason for this difficulty may be due to lack of proper link between geometry and numerous applications as it relates directly to the learners such as building, engineering and architecture. But Inekwe and Hassan (2002) related the problem to the problem of semantic use of geometric concepts. While in a meta-analysis that covers more than 100 countries Nicole, Marcia and Janet (2010) found that, the quality of instruction and curriculum affect children's Mathematics learning. They added that female is likely to perform as well as male when they are encouraged to succeed.

Records show that, in Nigeria the prevailing method of Mathematics instruction among secondary school Mathematics teachers are expository lecture method (Adetula, 1988). He further commented that, yet the method doesn't yield the desired result. Nevertheless, in search for qualitative and viable approach of Mathematics instruction, researchers advocated for the use of problem solving approach (Obodo, 1997; Bolaji, 1999 and National Council of Teachers of Mathematics, 2000). They individually argued that, the approach not only engages students in thinking, exploring and actively doing Mathematics, it also helps the learners to retain Mathematics knowledge for longer period. Due to the role of retention in learning process, Davis (1979) maintained that, if the learner cannot retain the effects of previous learning experiences, there could be no progress from one practice period to another.

Hence, it is the focus of this study to ascertain whether problem solving approach can bridge the gap between male and female mean achievement and retention of geometry concepts (assumed difficult topic). Consequently the following research questions are generated.

- i. What is the nature of the difference between the mean scores of male and female achievement when taught geometry using problem solving approach?
- ii. Is there any significant difference between the mean scores of male and female students in geometry retention test when taught using problem solving approach?

To answer the above questions, the following null hypotheses were formulated for testing:

HO₁: There is no significant difference in male and female students mean score in geometry Achievement test when taught using problem solving approach.

HO₂: There is no significant difference in male and female mean scores in geometry retention-test-when taught using problem solving approach.

METHODOLOGY

The research design adopted for this study was pre-test post-test experimental control group design. The population of this study was all year 3 Senior Secondary school students in Jigawa state government owned schools. Thus, the total population of this is 9,540 from 42 senior secondary schools. A sample of 70 students comprising of 35 male and 35 female were selected from one male and one female using stratified and "drawing from the hat" random sampling techniques in line with (Akuizuilu, 1993)

In this study the experimental group was taught geometry using problem solving approach (Polya, 1962) model by the researcher. While the control group was treated the same topics using traditional method by a trained colleague, whose qualification and experience are equivalent to that of the researcher, in order to control teacher factor variable. For the two groups the teaching lasted for six weeks. Three instruments were used for data collection in this study. Researcher made test (RMT) was used as pre-test to determine the entry level of the subjects. Geometry Achievement Test (GAT) was used to measure the students Geometry Achievement Test. While Geometry Retention Test (GRT) items were generated by shuffling and rotating GAT items, and were used to measure geometry retention level which was conducted two weeks after administration of post-test.

The GAT and GRT consist of 20 multiple choice geometry questions sorted and adapted from WAEC past question papers. And they cover essential geometry topics in senior secondary school Mathematics curriculum. The reliability coefficients of GAT and GRT for this study were obtained to be 0.67 and 0.66 respectively using

K-R-21 Kuder-Richardson formula. Three experienced degree- holders' secondary Mathematics teachers validated the items and their inputs were incorporated.

Scores from the instruments were collected and statistically analyzed using t-test statistic at 0.05 level of significant.

RESULTS

Table 1: Performance of the Experimental and the Control Groups in Pre-test.

GROUP	N	X	Sd	Df	T _{cal}	T _{crit}	P	Remark
MALE	35	37	12.6	68	0.88	1.96	0.38	NS
FEMALE	35	35.4	12.6					

Not significant at $P > 0.05$

From Table 1: p-value = 0.38 which is greater than 0.05. This implies that there is no significant difference between male and female in their pretest scores. This also means that, the two groups could be assumed to have equivalent prior knowledge on geometry at the point the investigation commenced

HO₁: There is no significant difference between male and female student mean scores in Geometry Achievement Test when taught using problem solving approach.

Table 2: Comparisons between males' and females' mean scores in geometry achievement test (GAT)

Group	N	\bar{X}	Sd	df	T _{cal}	T _{crit}	P	Remarks
Male	35	63	15	68	4.12	1.98	0.01	S
Female	35	49	13.2					

Significant at $P \leq 0.05$

The result from table 2 shows a p-value 0.01 which is less than p of significant level. This shows that, there was significant difference between males' and females' performance in the post-test. Moreover, the calculated t-value of 4.12 which is greater than critical value of t which is 1.98 with df = 68 at $p \leq 0.05$. Thus the null hypothesis is rejected. This implied that the approach favoured male.

HO₂: There is no significant difference between males and females mean scores in geometry retention test (post-post test) when taught using problem solving approach.

Table 3: Comparison Between Males' And Female's In Geometry Retention Test (GRT)

Group	N	\bar{X}	Sd	df	T _{cal}	T _{crit}	P	Remarks
Male	35	57.3	12.5	68	1.9	1.98	0.06	NS
Female	35	51.4	13.4					

Not significant at $P > 0.05$

The result from table 3 revealed a p-value of 0.06 which is greater than p of significant level; this shows that, there is no significant difference in the performance of female and male taught geometry using problem solving approach in retention test. Moreover, the obtained t-value is 1.9 which is less than the $t_{critical}$ value 1.98 with $df = 68$ at $P \leq 0.05$ level of significance. Thus null hypothesis is therefore accepted.

DISCUSSION OF THE RESULT

The results in table 2 shows that, there was significant difference between the performance of male and female with respective mean scores of 63% and 49% respectively. However the mean score of 49% is appreciable in normal scores. The implication of this result is that, problem solving approach tends to promote homogeneity of male and female performances. The findings of Abbas (2008), Batista (1990) and Casey et al (2001) are consistent with the findings of this study. Possible explanation, could be due to the fact that problem solving approach makes female to participate, interact, collaborate more than when treated through traditional approach, yet the method favoured males in terms of geometry achievement.

Table 3 shows that, the difference in performance of male and female in the retention test is not significant with p-value 0.06 at $P \leq 0.05$ significant level. This shows that the method tends to bridge the wide gap that exists between male and female performances in Mathematics.

The findings agrees with that of Awang & Noor (nd) and Mulli (1998) who discovered that problem solving approach is not sensitive to gender difference. On the other hand it disagrees with the findings of Fennema & Sharma (1978) and Bolaji (1999) that confirmed the existence of gender difference in learners' cognitive performance. This will probably be as result of latent feature of problem solving approach; where the concept learnt are not allowed to be forgotten through use and over-use of the concepts in solving a given problem. Moreover, in respect of sex, students are motivated and compelled to participate fully in the process of learning. Hence, the more the female participate in learning process the better in retaining the concept learnt.

CONCLUSION

This study has shown that Problem Solving Approach (Polya model) can be used to bridge the gap between male and female performance in geometry achievement and retention.

RECOMMENDATIONS

From the findings of this study, the following recommendations were made.

1. Mathematics teachers should be trained and encourage to incorporate the use of problem solving approach in their lessons.
2. Professional bodies like Mathematics Association of Nigeria (MAN), Science Teachers Association of Nigerian (STAN) should put more effort in organizing workshops and conferences to teach Mathematics teachers on how to employ problem solving approach effectively.
3. Mathematics educators and curriculum developers should also encourage the production of text books and teachers guide; to aid and facilitate teaching and learning through the problem solving approach.

REFERENCES

- Abbas, M. G (2008). The effect of problem solving Approach on Achievement and Retention of Geometrical concepts among senior secondary school students. Unpublished M.ed Thesis. A.B.U. Zaria.
- Abiam, P.O and Odok, J.K (2006). Factors on Students Achievement in Different Branches of Secondary School Mathematics. *Journal of Education and Technology* 1(1), 161 – 168.
- Adeleke, M.A. (2007). Gender Disparity in Mathematical Performance Reviewed: can Training in problem solving bring difference between boys and girls? *Essays in education* Vol. 21 retrieved from www.use-educ/eassys/vol/21/2007/adeleke
- Adetula, L.O. (1988). Teaching to improve students problem solving abilities. *African Mathematics series* 2(1).
- Akuizuilo, E. (1993). *Research Methodology and Statistics*. Nuel Centi Publishers. Capital Territory.

- Awang, H, and Noor, A.I (nd). Difference in Mathematics learning in Malaysia, retrieved on 6/26/11 www.leadadmin/user_upload/rc2006/IEA_program
- Batista, M.T. (1990). Spatial Visualization and gender difference in high school geometry. *Journal of research in Mathematics education* 21 (1) 47 – 60
- Bolaji, C. (1999). Effectiveness of Problem solving strategies for teaching Algebraic word problems in junior secondary schools. *ZAJES: Zaria Journal of Education Studies* 3(1), 93 – 99.
- Casey, M.B, Nuttall, R.L and Pezari's, L. (2001). Spatial – mechanical reasoning skills versus Mathematics self confidence as mediators of gender differences on Mathematics subset using cross-national gender-based items. *Journal for research in Mathematics* 32(1) 28–57.
- Davis, M (1979). The effectiveness of guided inquiry/discovery approach in an elementary school science curricular an abstract Int, pp 416.
- Fennema, F.H. and Sharma, J.A. (1978). Sex-related Differences in Mathematics achievement and related factors. *A further study, journal study, journal for research in Mathematics education* 9(3), 189-203.
- Ibrahim, M.O. (1998). *Level of Geometrical thinking of Nigeria Senior Secondary school students*. Unpublished M.ed thesis A.B.U Zaria.
- Inekwe, I.O and Hassan A.A. (2002). Relationship Between visual perception of geometric shapes and achievement of students in secondary school, *Educational review*, Sokoto, Usman Danfodiyo University
- Kajuru, Y.K. (1995). The development and Assessment of Teachers Guide on the Teaching of Geometric concepts in the Junior Secondary School unpublished Ph.D thesis A.B.U Zaria.
- Lassa, P.N (1986). *Problems and Prospects of Mathematics Teaching and Learning in African Schools*. A paper presented at the 2nd Pan African congress at University of Jos, Nigeria.
- Manger, T. (1996). Gender Differences in Mathematical Achievement at the Norwegian Elementary school level. *Psychology Abstract* 83(3).
- Mulli, V.S. (1998). Education Achievement and Sex–Discrimination (Do national assessment of Education progress).
- National Council of Teachers of Mathematics.(NCTM)(2000). Principles and Standards School Mathematics. Reston, VA: NCTM
- National Population Commission (NPC 2006). Nigeria.
- Nicole, M.E, Janet, S.H, Marcia, C.L (2010). Cross-Sectional Patterns of Gender Difference in Mathematics. A Meta Analysis. *Psychological Bulletin*. 136(1) 103 – 121. Retrieved on 26/6/2011. from <http://www.sciencedaily.com/news/mind-brain/gender-difference/>
- Obodo, G.C. (1997). Principles and Practices of Mathematics Education in Nigeria. Enugu State University of Technology Enugu.
- Polya, G. (1962). Mathematical Discovery on Understanding, Learning and Teaching problem Solving (Vol.1) New York, Willey.

FAILURE IN MATHEMATICS

Lamin SAIDY

The learning and teaching of mathematics in our schools cannot be over emphasized. Its importance is quite enormous and so vital to our daily lives in this 21st century.

But, in my part of the World, Africa, to be specific, The Gambia, West Africa, it is a very big concern to both partners in education, that is parents, educators, teachers, donors and all those in the training of teachers, that is University of The Gambia and The Gambia College-School of Education, pupils are every year failing Mathematics at both internal and external examinations for both the Lower Basics Schools, Upper Basic Schools and Senior Secondary Schools.

At the Lower Basic Schools, pupils in grade threes and fives sit to the National Assessment Test NAT and according results given by West African Examination Council WAEC, the number of candidates failing Mathematics is on the increase at an alarming rate.

In the upper Basic School level, pupils in grade nines nationwide, the number candidates failing Mathematics is also very high each year after The Gambia Basic School Certificate Examination results are released by WAEC.

Also in the Senior Secondary School sector, it is more pathetic because this is the transition stage to University and in The Gambia, before a candidates gets admission into The University of The Gambia, you must have a credit of a minimum of six 6 grade in both English and Mathematics and i want to belief, it is the requirement if not all Universities in the entire World. Now tell me if candidates or pupils fail Mathematics at these levels, then what will happen to the future of our education sectors, because these will be the teachers and stake-holders in the education, it will be detrimental then since the World cannot go without Mathematics, its concerning.

Keywords: TEACHING OF MATHEMATICS IN SCHOOL

SINIF ÖĞRETMENLERİNİN FEN VE TEKNOLOJİ ÖĞRETİMİNE YÖNELİK TUTUMLARI

Seyat POLAT

Ahmet ÖZCAN

ÖZET: Fen ve Teknoloji dersi, öneminden dolayı Türkiye’de ilkököl 4. sınıftan itibaren öğretim programlarında kendine yer bulmuştur. Eğitim-öğretim sürecinin en önemli aşamalarından biri olan İlkokulun ilk dört sınıfında görev alan sınıf öğretmenleri görevleri gereği Fen ve Teknoloji dersini anlatmaktadırlar. Dolayısıyla öğretmenlerin Fen ve Teknoloji öğretimi konusundaki tutumları büyük önem taşıdığı söylenebilir. Bu çalışma sınıf öğretmenlerinin Fen ve Teknoloji dersinin öğretimine yönelik tutumlarını incelemeyi amaçlamaktadır. İlişkisel tarama modelinde desenlenen çalışmada kullanılan ölçek iki boyuttan oluşmaktadır. I. Boyutu öğretmenlerin, cinsiyetleri, kıdem durumları ve lisede mezun oldukları alan oluşturmaktadır. Thompson ve Shringley (1986), tarafından geliştirilmiş; Tekkaya, Özkan ve Çakıroğlu (2002), tarafından Türkçeye uyarlanmış 10 maddesi olumlu ve 10 maddesi olumsuz olan bölüm ise ölçeğin II. boyutunu oluşturmaktadır. Çalışma, 2014 yılında Konya ili Meram merkez ilçesindeki ilkokullarda görev yapan sınıf öğretmenleri ile yürütülecektir. Araştırma kapsamında veriler toplanıp çözümleme işlemleri yapılacaktır.

Anahtar Kelimeler: Fen ve Teknoloji öğretimi, Sınıf Öğretmeni, İlkokul

oooooooooooooooo

CLASSROOM TEACHERS ATTITUDES TO TEACHING SCIENCE AND TECHNOLOGY

Seyat POLAT

Ahmet ÖZCAN

ÖZET: Fen ve Teknoloji dersi, öneminden dolayı Türkiye’de ilkököl 4. sınıftan itibaren öğretim programlarında kendine yer bulmuştur. Eğitim-öğretim sürecinin en önemli aşamalarından biri olan İlkokulun ilk dört sınıfında görev alan sınıf öğretmenleri görevleri gereği Fen ve Teknoloji dersini anlatmaktadırlar. Dolayısıyla öğretmenlerin Fen ve Teknoloji öğretimi konusundaki tutumları büyük önem taşıdığı söylenebilir. Bu çalışma sınıf öğretmenlerinin Fen ve Teknoloji dersinin öğretimine yönelik tutumlarını incelemeyi amaçlamaktadır. İlişkisel tarama modelinde desenlenen çalışmada kullanılan ölçek iki boyuttan oluşmaktadır. I. Boyutu öğretmenlerin, cinsiyetleri, kıdem durumları ve lisede mezun oldukları alan oluşturmaktadır. Thompson ve Shringley (1986), tarafından geliştirilmiş; Tekkaya, Özkan ve Çakıroğlu (2002), tarafından Türkçeye uyarlanmış 10 maddesi olumlu ve 10 maddesi olumsuz olan bölüm ise ölçeğin II. boyutunu oluşturmaktadır. Çalışma, 2014 yılında Konya ili Meram merkez ilçesindeki ilkokullarda görev yapan sınıf öğretmenleri ile yürütülecektir. Araştırma kapsamında veriler toplanıp çözümleme işlemleri yapılacaktır.

Keywords: Science and technology education, Class Teacher, !School!

PEDAGOJİK ALAN BİLGİSİ BİLEŞENLERİNDEN ÖĞRENCİ DÜŞÜNCESİ BİLGİSİNE YÖNELİK BİR LİTERATÜR TARAMASI

A LITERATURE REVIEW ON ONE COMPONENT OF PEDAGOGICAL CONTENT KNOWLEDGE “KNOWLEDGE OF STUDENTS’ THINKING”

Berna TATAROĞLU TAŞDAN
Dokuz Eylül Üniversitesi
berna.tataroglu@deu.edu.tr

Adem ÇELİK
Dokuz Eylül Üniversitesi
adem.celik@deu.edu.tr

ÖZET : Bir öğretmenin etkili bir öğretim gerçekleştirebilmesi için sahip olması gereken farklı bilgi türleri vardır. Fakat öğretmen bilgisi karmaşık bir yapıdır ve bu nedenle de pek çok araştırmacı tarafından tanımlanmaya çalışılmış ve çeşitli sınıflandırmalarla ele alınmıştır. Öğretmenin sahip olması gereken bilgileri belirlemeye yönelik yapılan çok sayıda araştırma olsa da pek çoğu için başlangıç noktası Shulman’ın (1986) çalışmaları olmuştur. Shulman (1986) “öğretmenin ne bilmesi gerekir?”, “öğretmenin dersi anlatırken ne yapması gerekir?”, “öğretmenin sahip olması gereken bilgiler nelerdir?” sorularına cevap aramak amacıyla pedagojik alan bilgisi kavramını ortaya koymuş ve üzerine çalışmaya başlamıştır. Ona göre pedagojik alan bilgisi, konu alan bilgisi ve pedagoji bilgisinin özel bir bileşimidir. Bir başka tanımında pedagojik alan bilgisini, konu bilgisinin pedagojik bilgi ile kesiştiği, uygulama bilgisi ile kuramsal bilginin bütünleştiği, bir konunun öğretimi bilgisi olarak tanımlamıştır (Shulman, 1987). Shulman’ın çalışmalarından sonra öğretmen bilgisi pek çok araştırmaya konu olmuş ve araştırmacılar öğretmenin sahip olması gereken bilgileri kategorilere ayırmada farklı modeller ortaya koymuşlardır. Öğretmen bilgisinin ele alındığı modellerde bakıldığında, öğrenci düşüncesi bilgisini pedagojik alan bilgisinin bir bileşeni olarak ele alma konusunda araştırmacıların hem fikir oldukları söylenebilir. Modellerde bu bilginin öğrenenler ve karakteristikleri bilgisi, öğrenci anlamaları bilgisi, öğrencilerin matematiği kavrayışları bilgisi, öğrencilerin düşünceleri hakkında bilgi gibi terimlerle yer aldığı görülmektedir. Tanımlarına bakıldığında ise farklılaşan kimi noktaları olsa da çoğunlukla benzer bir kapsama işaret etmektedirler.

Bu çalışmada pedagojik alan bilgisinin bir bileşeni olan öğrenci düşüncesi bilgisine yönelik bir literatür özetinin sunulması amaçlanmıştır. İlk olarak pedagojik alan bilgisinin bileşenleri ve ortaya konulan modellerde öğrenci düşüncesi bilgisinin yeri incelenmiştir. Daha sonra öğrenci düşüncesi bilgisi kapsamlı olarak irdelenmiştir. Öğrenci düşüncesi bilgisinin alt bileşenleri incelenen literatür ışığında; öğrencilerin mevcut bilgilerini ortaya çıkarma, ön bilgi ile yeni bilgiyi ilişkilendirme, öğrenci sorularına ve düşüncelerine değer verme, öğrenci düşüncesini ön görme, öğrencilerin kavram yanlışlıklarını belirleme ve bireysel farklılıkları dikkate alma şeklinde sıralanmıştır.

Anahtar sözcükler: öğretmen bilgisi, pedagojik alan bilgisi, öğrenci düşüncesi bilgisi

ABSTRACT: There are different types of knowledge that a teacher need to have for making an effective teaching. But teacher knowledge is a complex structure and therefore it has been defined by many researchers and dealt with different classifications. Although there are so many studies done for determining teacher knowledge, Shulman’s (1986) has been the origin of many of them. To find answers to the questions “What do teachers need to know?”, “What must teachers do during her/his instruction?”, “What are the knowledge that teachers need to know?”, Shulman (1986) suggested the concept of pedagogical content knowledge and started to study on. According to him pedagogical content knowledge is a special amalgam of content and pedagogy. In another definition he defines pedagogical content knowledge as knowledge of teaching a subject in which content knowledge and pedagogical knowledge intersected and practical knowledge and theory integrated. After Shulman’s studies, teacher knowledge became the subject of many researches and the researchers suggested different models to categorize teacher knowledge. When we look these models it can be said that knowledge of students’ thinking is agreed on as a component of pedagogical content knowledge. This knowledge is seen in the models as terms like knowledge of learners and their characteristics, knowledge of students’ understanding, knowledge of students’ cognitions in mathematics. In the definitions although there are some different points, they generally indicate the same content.

In this study it is aimed to present a literature review on knowledge of students' thinking which is one component of pedagogical content knowledge. First, the components of pedagogical content knowledge and the place of knowledge of students thinking in the models were examined. Then, knowledge of students' thinking was examined thoroughly. In the light of the literature the subcomponents of knowledge of students' thinking were organized as: eliciting studentst' current knowledge, connecting prior knowledge to new knowledge, valuing students' questions and thinking, foreseeing students' thinking, determining students' misconceptions and considering students individual differences.

Key words: teacher knowledge, pedagogical content knowledge, knowledge of students' thinking

SERVICE LEARNING IN SCIENCE TEACHER PREPARATION PROGRAM: CONCEPTS AND PRACTICES

Prasart NUANGCHALERM

Faculty of Education, Mahasarakham University THAILAND

Corresponding author e-mail: prasart.n@msu.ac.th

ABSTRACT: Service learning is now challenging higher education in the 21st century. The concepts of service learning influenced to science teachers preparation program in terms of outcome-based education. The purpose of this paper aims to represent concepts relevant to service learning in science teacher preparation program and also practices of how service learning meet the 21st century skills. Documentary analysis and empirical study are employed for qualitative explanation. Finding revealed that service learning is an important instructional strategy in science teacher preparation program and it needs to be incorporated into curriculum for developing 21st century science teachers.

Keywords: service learning, preservice teacher, science teacher, teacher preparation

INTRODUCTION

Learning process in the 21st century is not appeared only in classroom-based activities, but also community service should be introduced in various kind of learning management to higher education level. That is, previous research (Zlotkowski, 2000; Gallego, 2001; Kaye, 2004; Butin, 2005; Butin, 2010; Coffey, 2011; Daniels *et.al.*, 2011; Cone, 2012) help us to understand how to manage learning environment that meet requirement between curriculum and nature of learning. This era, we cannot deny learning management innovation propagating academic and community hit to the goal of higher education. Coffey (2011) states that the number of higher education institutions using ways to serve students' learning with service-learning programs, it is greatly increased within the last twenty years, especially teacher education programs are using them to help teacher candidates achieve an awareness of social and community issues. That is, higher education should be take responsibilities to social relations. Due to students come from community and serve community as well. They have to do with a civic mission that addresses important issue. Service learning is a significant instructional strategy which university should incorporate into course and learning activities.

Community experiences can make preservice teachers with positive attitudes, academic, skills, and attributes that classroom maybe give them less opportunity to fulfill of what they should be prospered because of school hour is limited. That why university reason lectured-based learning is restricted by content matter and space of learning. Based on framework of higher education concerns with many sectors, learning process should be widely participated in terms of community development, students are centered-based, community-based, and practical-based needed to shape society. It is expected academic aspect and reflection which encourage our citizen autonomy and control, help them realize the link between their effort and success promote development of environmental awareness. Service learning is an educational methodology that combines community service with explicit academic learning objectives, preparation for community work, and deliberate reflection (Benneworth & Charles, 2013). It engages students within the local community through completion of a hands-on construction project which response to civic engagement (Benneworth & Humphrey, 2013; Clevenger & Ozbek, 2013; Hart & Aumann, 2013).

Service learning brings students and teachers to the open learning area. They have learning skills from real life situations and problem-solving. Meanwhile, service learning have itself responsible to shape way of learning by cooperative inquiry-based practices, students will have problem-solving skills and decision making through project work and serve learning outcomes through empirical evidences by community services. We can recognize instructional practices in the university level should not only emphasize on theory, most of study indicated that theoretical knowledge cannot be helped preservice teachers to fulfill learning skills. The educational practices in higher education should be focused on how learning reaches the model of learning and its assessment (Astin & Antonio, 2012). Thus, the assessment should response to societal impact, relevant to higher education produced knowledge and human resources to society.

The notion of service learning is not new for education, is referred by experiential learning theory (Kolb & Kolb, 2005), it is influential regarding as it provides a model of the learning process as well as model of adults' learning development. Preservice science teachers should have appropriate learning environment that institution support by various kind of theoretical-based and practical-based management. Service learning shows us socially responsible and responsive instructional practices. It also influences to authentic learning outcomes, critical reflection, and civic engagement (Galvan & Parker, 2011). Moreover, it is an approach to teaching in which links community-based service academic and critical reflection, leads them meet the goal of experiential learning theory. This approach helps higher education curriculum build preservice teachers to have assumption a leadership role in addressing widespread of social and environmental problems, and to prepare them to be a good citizenship making them to meet the needs of a rapidly social changes (Boyer, 1990). Service learning connects authentic, meaningful service to community as well as they supported, especially to community with academic and reflection in which they have learned through scientific thinking, systemic plans, and cooperating practices (Eyler & Giles, 1999).

Service learning enhances preservice teachers' abilities in many ways by allowing them to have learning opportunities, link academic and theories to work with real life situation, various kinds of pedagogical practices, 21st century learning skills, social awareness, and public mind to community. As it great for learning activities in higher education, service learning incubates them not only general courses, but also preservice teachers who is lead and shape our society. According to Cone (2009a; 2009b; 2009c) studied the effect of service learning in the role of approach to enhance self-efficacy beliefs of preservice elementary teachers. The findings indicated that service learning is significantly influenced to preservice teachers with outcome expectancy towards equitable teaching and learning. It will stimulate them to have self-efficacy, has been linked to educational outcomes (Bandura, 1997). It is directly associated with behavioral, cognitive, and motivational engagement of them on academic practices (Bandura, 1993). If they have all of above and perceived that it is importance to have higher levels of cognitive engagement and also some related to their attributes (Eccles & Wigfield, 2000).

To developing preservice teachers, service learning in science teacher preparation program should fulfill cultural, social and academic awareness as well as curriculum determined.

Service-learning in teacher education programs is now growing trend in universities level which is around the world. Preservice science teachers are particularly prospered leader and transformer of social direction. The program should be challenged 21st century skills that learning realization is overcoming in the complex society. We can say that it is an important guideline to think, imagine, plan, do, and assess for preparing quality citizen in a changing world. This study aims to present concepts and practices of service learning in science teacher preparation program. The results will be discussed and guided to curriculum development and instructional practices for science teacher preparation program.

METHODOLOGY

This study employed documentary analyses in service learning for science teacher preparation program. Document analyses are investigated through standard databases in both Thai and international sources. Thai databases can be accessed through ThaiLis, ONEC, Google Scholar, and universities' WebOPAC. International database are linked to ERIC, EBSCOHOST, Proquest, Google Scholar, Scopus, and ISI Web of Science. Information is gathered by keywords, methods, and contents related to service learning in higher education, and it is screened only related preservice science teachers and service learning documents. Concepts are drawn, reviewed, and analyzed by content analysis methods. Data are described in terms of qualitative presentation, descriptive report, and gap analysis.

The practices are reviewed research in service learning, especially for science teacher preparation program. Also, data from practices and experiences are collected through observation, participatory action, and reflection. The service learning by practical data is observed through science teacher service camp, which it have been run for 10 years in Bachelor degree of General Science program, Mahasarakham university. It can conclude to be instructional strategies. Then, researcher analyzed data and explained empirical evidences by descriptive explanation.

RESULTS

Social responsibilities are now calling for 21st century because we have too much knowledge and technology in which concerns unlimited cognitive growing, but necessary skills and attributes need to be done with high quality education, high quality citizens facing complex modern life and innovation for surviving. The process of learning in school or university should not be concentrated only subject matters because the world is change, problem is more complex, natural resources and environment are ruined. Society call for all sectors to have responsibilities and awareness to do with friendly action that is education can change. Challenging reason, hands-on and mind-on activities leads students to have contemporary skills and 21st century experiences, experiential learning (Kolb and Kolb, 2005) states in the currently educational strategies because beliefs in no one learn without think and practice. The meaningful learning by head, heart, and hand with deep responsibility to social awareness is propagated at all level. The process of service learning seems to science teacher preparation in Thai university in terms of community service or preservice science teacher camp. However, student-centered based learning is implemented as it the project assignment.

Preservice science teachers decided to conduct project or science camp by norm or university culture. It cannot be indicated that real service learning implemented or occurred in the process of learning in higher education. They have learned culture and others community dimension by starting to select target community through group discussion via possibility of project cooperation. Then, they have to teach or construct school environments as well as school administrator wants. Finally, they move back to traditional class in university to register several courses by means of project ending and restart with another community that traditional ceremony recommended. It can be concluded that paradigm of community service is still implement in terms of traditional ceremony between community and preservice science teachers (Figure 1).

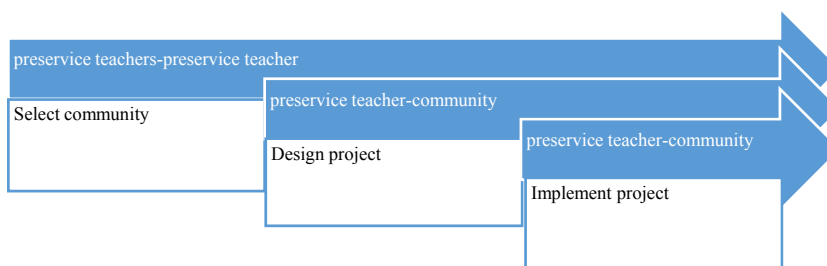

Figure 1. Community Service And Preservice Science Teachers

The instructional strategies of service learning can be generalized to preservice science teacher preparation with previous result of the study. Based on my teaching experiences and research findings (Prasertsang & Nuangchaleram, 2013; Prasertsang *et.al.*, 2013; Nuangchaleram, 2014a, Nuangchaleram, 2014b), it can be described that service learning can summarize at least 3 phases of instructional practices.

Preparation: it has been known that the initial phase of learning will hit the requirement of learning objectives preparation seems to classroom conditioning as it traditional for general classes. It is the first instructional process, allow students to have concept in teachers' role and community development. They spent time for planning of what project should be done and problem should be solved. They formed group and work with others by effective communication. Leadership is begun during project planning. Community pilot study is not ignored because it will give them necessary data to making decision. They gathered some information that concerns with community-based service learning by employing scientific thinking as well as science teachers be. This phase, stimulate and inspire their attributes of how to be a good citizen based on concept of good democracy, good citizen, and serving good community. They have to spent mostly time for preparation, not only project investigating community service but also knowledge in such they have to know before group entering.

Teacher will give them goal of working by lecture-based learning and group-based discussion with how to sustain community, especially implication of theoretical knowledge in classroom into real life situation.

Teacher as a key person to inspire students producing community service and stimulate them to have scientific thinking which is not emphasize theoretical perspectives but also case studies are introduced. Students take responsibilities to work with community members by various kind of knowledge construction such as observation, talking, photography, dialogues, community record, and so on to help them make possibility of successful in community service program. They are guided in teachers' profession and way of group working, team working, and problem-solving. Walk and talk are prior knowledge that they should do with community members.

Action: everything will not be success if we deny learning by doing. The concept of any learning theory didn't ignore to stating students interact with natural world through direct experiences. Sensory organ works with brain function, it migrates perception by seeing, hearing, smelling, tasting, and touching. The second phase of service learning process let preservice teachers having experiences that looks different traditional classroom may be emphasized subject matters or theory-based learning. It allows them to work with community members and peers by conducting project as they planned, team-based learning, project-based learning, and problem-based learning. Learning activities help students to have 21st century skills during action phase i.e. scientific thinking skills, life skills, innovation skills, ICT skills, science process skills, learning skills, and so on. They have to do as they plan with community members, project is implemented with assignment then various kind of data collection method are employed by video recording, photography, journal writing, discussion and report. Each group has to record and assess the goal of project by conducting a small research, interviewing, observing, making questionnaires, and videotape recording. The outcome of this process response the project in which serve community's needs with learning together between community and university. They have to talk with others, share ideas, construct knowledge through effective communication.

This phase teachers should divide preservice science teachers to group-based community service, each group consist of 10-15 person. Teacher is facilitator by guiding concept, methods, and techniques to do with community and also giving tools for collecting data and methodology for examining community service. Time for action is no too short or too long because it influenced to project-based service. Hidden curriculum, determined preservice science teachers pay attention to community awareness, civic engagement, social

responsibility that it difficult to understand in only theoretical-based classroom. Action is important methods open the world of knowledge to them. They have to move themselves to community and response to the real needs by doing with community members. Boundary of knowledge in social, cultural, political, and economical dimension is moved, they employed educational research after had learned from university. They can think and do various kinds of cooperating learning strategies.

Reflection: this learning process will be conducted when they back to classroom, presentation and reflection by whole class is set. Each group presents of what they did and how the project reaches the goal of study. The classroom activity assigned all group members prepare what they had learn through project-based construction and community service. Video recording, questionnaire, report, and presentation are important evidences to indicate successful in service learning.

“...I have a chance to repair school playground. When I do, it is not easier than those I think. Moreover, community members are warmest welcome to all students during project conducted...” Sunny

“...community members take care all of us with warmest welcome, food and supplies are transferred by community members to our service camp. The deepest expression that I remembered in the last day, he ride a bicycle followed our truck and shout loudly “forget me not, please revisit us” ...” Lisa

“...the service project allowed us to fulfill knowledge and skills that we cannot buy anywhere, science show invite us to learning by happily doing because all of sectors such as students, community members, and school administrator give us to learn together in cooperatively...” Lita

“...service project taught us to plan, act, observe, and reflect in what we do. We learn to talk and discuss a lot for implementing community service. I am confidently project service employed active learning to us for knowledge construction...” Punch

Participants expressed their understanding in the concept of civic education and practical knowledge in terms of community service. They employed various kind of presentation i.e., powerpoint, poster, video, and report for concluding about what they had learned by project-based activity. Reflective writing is also employed to indicated that each of them reach the concept of citizenship. Moreover, ICT skills let them to make clip video to show of what and how they implement community-problem and community-project services through social network. Effective communication is such incubated and challenged them to learn how perceived a successful project. Also, it develops them to have science and art to share their ideas with others in which helps them to be good teacher and transporter of knowledge, skills, and expected attributes to all students.

DISCUSSION

Teacher preparation program seems significant for shaping our society because teacher is an key person and factors that point society to of what we are. Program consists of both educational theories in which represent in classroom and also field experiences or school practicum. Educational policy promote way of effective teacher construction, as the current of teacher preparation in the world, teacher profession in the changing world must skeptic them to real life situation, solve the problem as they found, set a project, and service not only academic, but necessary skills might want to examine in the community. Field experiences in preservice science teachers declares knowledge and skills that include profession’s attributes, community as a sources of learning, textbook cannot transmission of what students perceived even though they take time to work with community.

Based on individual differences, students have to adapt way of working, learn way of knowledge construction, and consume way of socio-cultural action. However, curriculum and instruction in university is limited to lecture-based learning or emphasizing theory than those practical learning. The concept if service learning is designed for 21st century skills, suitable for creative learning innovation that students will learn from of what they work as well. The field experiences, sources of knowledge construction, difficult to teach in the classroom because it needs real and solve the problem by group working. It responses of what teachers should be success as good as teacher professions defined. ICT is employed and subject matter as they have learned, it will be used for creating learning innovation and community readiness.

The teacher preparation program is now time for updating or renovate curriculum by incorporating service learning strategies into science teacher preparation program, allowing them to meet profession and match the goal of program. The activities that found in the field experiences, service learning employed project-based and problem-based learning, suitable for higher education, and practical-based than those lecture-based classroom. Due to, instructional strategies examined student-centered learning, learning by doing emphasizes, problem-based learning, and project-based learning which community is stakeholder.

Service learning can make professional teacher through project service, community and university is not far from borderline of academic or scholars, but it can make more closely by joining preservice science teachers with community members. Service learning can be summarized into 3 phases: Preparation, Action, and Reflection. Preservice science teachers and community members are planner to solve community problem (Zlotkowski, 2000). Higher-ordered thinking is key element that accelerate them to develop system thinking, academic outcomes, and skills according to Kolb (1984) states experiential learning that is process to develop abilities, experiences, and reflection (National Youth Leadership Council, 2010). Service learning initiated educators based on experiential learning (Kolb, 1984; Kolb & Kolb, 2005) theory, methods, ideas, and concepts are emerged by inner and outer classroom activities (Zins *et.al.*, 2010). It constructs positive relations among teacher, learners, and communities for enhancing learning skills and necessary abilities which they should be developed (Billig & Conrad, 1997). They will have much more skills and abilities as 21st century citizens. It should have by participation, problem-solving, planning, decision making, and practices. Community's problem had been solved, students learn to work with participatory action in collaboration with effective communication, life skills, and team working (Wiegand & Strait, 2000; Ferrari III & Cather, 2002). That is, it should be incorporated into classroom that higher education defined to hands-on and mind-on learning for citizens' learning in the 21st century.

As believed in good teacher profession, preservice science teachers should fulfill learning experiences by outside activities and service communities as much as they can do. It can be considered that hidden curriculum in community service is not to help them in way of working together, but also learning the differences is required. Preservice science teachers apprentice teachers' role and responsibilities. In the way of service learning, they have to prepare community where showed clearly needs to work with. Preservice science teachers should think and act based on community needs and problem bases by service learning as shown in Figure 2 (Prasertsang & Nuangchalerm, 2013).

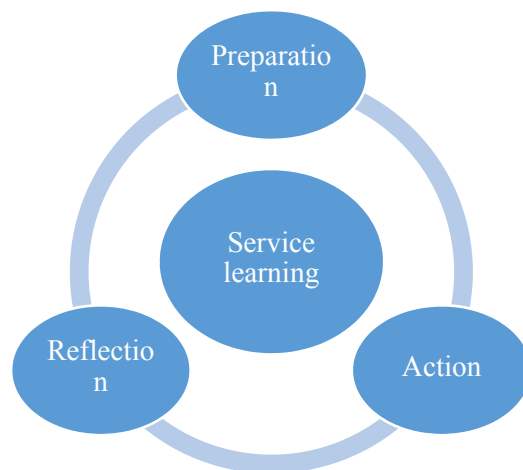

Figure 2. Service Learning Phases

They have a willing to serve community based on deep awareness to social responsibility, discuss of what they have learned from field experiences, and think about group-based learning through reflection (Clayton & Ash, 2005; Deely, 2010). Learning innovation is created as well as they have learned from university and adapted to local practices (Power, 2010). It needs them to have skills helping them to survive, learn, adapt, and contemplative practices. The outcome of service learning enhance characteristic of good citizenship (Scott, 2006; Prasertsang *et.al.*, 2013). It can be concluded that service learning explain itself in the role of education for holistic view in academic, skills, and attributes that response to social needs in the current situation and future. They have cooperating in participation in community sustainable development because they are outcomes of community to do and response to a partnership in education and development as well as they have a meaningful learning (Butin, 2005; Braskamp & Engberg, 2011). Community care is a best way to let them

participate in learning together with community members, happy, love, peace, awareness and social responsibility (Silcox, 1995; Galvan & Parker, 2011).

Preservice science teachers can classify community needs, share ideas together, they have to develop many skills for serving community which is not only cognitive, but psychomotor and affective sides will be developed (Kaye, 2004). It seems to them research-based active classroom and more scientific thinking (Nuangchalerm, 2009; Cartwright, 2012; Cone, 2012). Service learning and community-based experiences are effective in developing teacher preparation program (Nuangchalerm, 2014a; Nuangchalerm, 2014). They can learn much more cultural, academic, and social awareness, which is now growing trend in higher education around the world. Preservice science teachers learn a powerful way about community in which cultures of learning embedded (Boyle-Baise & Sleeter, 1998; Sleeter, 2000). It can be explained that direct experiences allow them to view, reflect, and change perspectives of how to develop their profession and attributes.

ACKNOWLEDGEMENT

I am very sincerely appreciated to Faculty of Education, Mahasarakham University for research supports.

REFERENCES

- Astin, A.W. & Antonio, A.L. (2012). *Assessment for excellence: the philosophy and practice of assessment and evaluation in higher education*. 2nd ed. Maryland: Rowman & Littlefield Publishers.
- Bandura, A. (1993). Perceived self-efficacy in cognitive development and functioning. *Educational Psychologist*. 28(2): 117-148.
- Bandura, A. (1997). *Self-efficacy: the exercise of control*. New York: Freeman.
- Benneworth, P. & Charles, D. (2013). University–Community Engagement in the Wider Policy Environment. In Benneworth, P. (Ed). *University engagement with socially excluded communities*. London: Springer Dordrecht Heidelberg.
- Benneworth, P. & Humphrey, L. (2013). Universities’ perspectives on community engagement. In Benneworth, P. (Ed). *University engagement with socially excluded communities*. London: Springer Dordrecht Heidelberg.
- Billig, S.H. & Conrad, J. (1997). *An evaluation of the New Hampshire service-learning and educational reform project*. Colorado: RMC Research.
- Boyer, E.L. (1990). In search of community. *Paper presented at the Annual Meeting of the American Council on Education*. Washington, DC. January 18, 1990.
- Boyle-Baise, M. & Sleeter, C.E. (1998). *Community service learning multicultural teacher education*. Washington DC: ERIC document reproductive service No. ED 429925.
- Braskamp, L.A. & Engberg, M.E. (2011). How colleges can influence the development of a global perspective. *Liberal Education*. 97(3-4): 34-39.
- Butin, D.W. (2005). *Service-learning in higher education: critical issues and directions*. New York: Palgrave Macmillan.
- Butin, D. (2010). *Service-learning in theory and practice: the future of community engagement in higher education*. New York : Palgrave Macmillan.
- Cartwright, T.J. (2012). Science talk: preservice teachers facilitating science learning in diverse afterschool environments. *School Science and Mathematics*. 112(6): 384-391.
- Clayton, P. & Ash, S. (2005). Reflection as a key component in faculty development. *On the Horizon*. 13(5): 161-169.
- Clevenger, C.M. & Ozbek, M.E. (2013). Teaching sustainability through service-learning in construction education. *International Journal of Construction Education and Research*. 9(1): 3-18.
- Coffey, H. (2011). Moving into communities: developing cultural competence with pre-service teachers through community service-learning experiences. *Partnerships: A Journal of Service-learning & Civic Engagement*. 2(2).

- Cone, N. (2009a). A bridge to developing efficacious science teachers of all students: community-based Service-learning supplemented with explicit discussions and activities about diversity. *Journal of Science Teacher Education*. 20: 265-383.
- Cone, N. (2009b). Community-based service-learning as a source of personal self-efficacy: preparing preservice elementary teachers to teach science for diversity. *School Science and Mathematics*. 109(1): 20-30.
- Cone, N. (2009c). Preservice elementary teachers' self-efficacy beliefs about equitable science teaching: foes Service learning makes a difference. *Journal of Elementary Science Education*. 21(2): 25-34.
- Cone, N. (2012). The effects of community-based service learning on preservice teachers' beliefs about the characteristics of effective science teachers of diverse students. *Journal of Science Teacher Education*. 23(8): 889-907.
- Daniels, K., Patterson, G. & Dunston, Y. (2011). Meeting 21st century teaching standards through service-learning pedagogy in pre-service teacher education. *Information for Action*. 3(2).
- Deely, S.J. (2010). Service-learning: thinking outside the box. *Active Learning in Higher Education*. 11(1): 43-53.
- Wigfield, A. & Eccles, J.S. (2000). Expectancy–value theory of achievement motivation. *Contemporary educational psychology*. 25(1): 68-81.
- Eyler, J. & Giles, D.E. (1999). *Where's the learning in service learning?*. California: Jossey-Bass Publishers.
- Ferrari III, N.D. & Cather, G.A. (2002). Community service, learning and the medical student. *Education for Health*. 15(2): 222-227.
- Gallego, M. (2001). Is experience really the best teacher?: the potential of coupling classroom and community-based field experiences. *Journal of Teacher Education*. 52(4): 312-325.
- Galvan, C. & Parker, M. (2011). Investigating the reciprocal nature of service-learning in physical education teacher education. *Journal of Experiential Education*. 34(1): 55-70.
- Hart, A. & Aumann, K. (2013). Challenging inequalities through community-university partnerships. In Benneworth, P. (Ed). *University engagement with socially excluded communities*. London: Springer Dordrecht Heidelberg.
- Kaye, C. (2004). *The complete guide to service learning*. Michigan: Free Spirit Publishing.
- Kolb, D.A. (1984). *Experience as the source of learning and development*. New Jersey: Prentice Hall.
- Kolb, A.Y. & Kolb, D.A. (2005). Learning styles and learning spaces: enhancing experiential learning in higher education. *Academy of Management Learning & Education*. 4(2): 193-212.
- National Youth Leadership Council. (2010). *The service-learning cycle*. Retrieved August, 2012, from http://www.nylc.org/sites/nylc.org/files/SLCycle_2PgHandOut.pdf.
- Nuangchalerm, P. (2009). Preservice teachers perception about nature of science. *The Social Sciences*. 4(5): 463-467.
- Nuangchalerm, P. (2014a). *Learning in science for 21st century*. Apichart Printing: Mahasarakham. (in Thai)
- Nuangchalerm, P. (2014b). Development of Service Learning for Preservice Science Teachers. *Journal of Thonburi University*. (in review).
- Power, A. (2010). Community engagement as authentic learning with reflection. *Issues in Educational Research*. 20(1): 57-63.
- Prasertsang, P. & Nuangchalerm, P. (2013). The development of service learning instructional model for pre-service teachers. *Higher Education of Social Science*. 4(3): 54-58.
- Prasertsang, P., Nuangchalerm, P. & Pumipuntu, C. (2013). Service learning and its influenced to pre-service teachers: social responsibility and self-efficacy study. *International Education Studies*. 6(7): 144-149.
- Scott, V.G. (2006). Incorporating service learning into your special education program. *Intervention in School and Clinic*. 42(1): 25-29.
- Silcox, H.C. (1995). *Motivational elements in service-learning: meaningfulness, recognition, celebration, and reflection*. Philadelphia: Brighton Press.

- Sleeter, C.E. (2000). Strengthening multicultural education with community-based service learning. In O'Grady, C.R. (Ed). *Integrating service learning and multicultural education in colleges and universities*. New Jersey: Lawrence Erlbaum.
- Wiegand, D. & Strait, M. (2000). What is service learning?. *Journal of Chemical Education*. 77(12): 1538-1539.
- Zins, J.E., Bloodworth, M.R. & Wiessberg, R.P. (2007). The scientific base linking social and emotional learning to school success. *Journal of Educational and Psychological Consultation*. 17(2-3): 191-210.
- Zlotkowski, E. (2000). Service-learning in the disciplines: strategic directions for service-learning research. *Michigan Journal of Community Service-Learning*. 7: 61-67.

ORTAÖĞRETİM MATEMATİK ÖĞRETMEN ADAYLARININ ÖĞRENCİLERİNİN HATALI ÇÖZÜMLERİNİ ÖNGÖRME BECERİLERİ

PRESERVICE SECONDARY MATHEMATICS TEACHERS' SKILLS IN ANTICIPATING THEIR STUDENTS' INCORRECT THINKING

Gülcan ÖZTÜRK

Balıkesir Üniversitesi, Necatibey Eğitim Fakültesi
ozturkg@balikesir.edu.tr

Gözde AKYÜZ

Balıkesir Üniversitesi, Necatibey Eğitim Fakültesi
akyuzgozde@gmail.com

ÖZET: Öğrencilerin matematiksel düşüncelerini geliştirmek için yapılması gerekenleri vurgulayan matematiksel düşünme odaklı öğretim uygulamasına katılan 40 ortaöğretim matematik öğretmen adayları ile gerçekleştirilen bu çalışmada, öğretmen adaylarının yapmış oldukları planlarda öğrencilerinin hatalı çözümlerini öngörme becerilerinin belirlenmesi amaçlanmıştır. Araştırmada deneysel araştırma desenlerinden tekrarlı ölçümler deseni ile nitel veri toplama yöntemlerinden doküman incelemesini içeren karma araştırma deseni kullanılmıştır. Öğretim uygulaması öncesinde, sonrasında ve bir yarıyıl sonrasında öğretmen adaylarına üst düzey düşünme süreçlerini içeren bir problem verilerek bu problem çerçevesinde planlar yapmaları istenmiştir. Planlar araştırmanın dayandığı teorik çerçeveye uygun bir araç olan ders planlama öğeleri rubriği ile incelenerek analiz edilmiştir. Yapılan analizler sonucunda öğretim uygulaması öncesindeki planlarda teorik çerçevedeki öğelerden biri olan öğrencilerin hatalı çözümlerini öngörmeye öğretmen adaylarının yetersiz oldukları görülmüştür. Öğretim uygulaması sonrasında ve bir yarıyıl sonrasındaki planlarda ise öğrencilerin yapabilecekleri hatalar açıkça ifade edildiği için öğrencilerin hatalı çözümlerini öngörme ögesinde öğretmen adaylarının başarılı oldukları ortaya çıkmıştır.

Anahtar sözcükler: matematiksel düşünme, matematik öğretimi, matematik öğretimini planlama

ABSTRACT: In this study, it is aimed to determine the preservice teachers' skills in anticipating students' incorrect thinking. The study was performed with 40 preservice teachers who participated in the instruction focused on mathematical thinking and emphasized what needs to be done to improve students' mathematical thinking. Mixed methods research including repeated measures design and content analysis was used in the research. The preservice teachers were asked to plan lessons that used a task with a high level of cognitive demand before, right after and one semester after the instruction. These plans were assessed and analyzed with scoring rubric for attention to students' thinking which is a tool compatible with the theoretical framework of the research. As a result of analysis, it was observed that the preservice teachers' skills in anticipating students' incorrect thinking, which is one of the components of the theoretical framework of the research, were inadequate before the instruction. In the plans right after and one semester after the instruction, it was emerged that the preservice teachers were successful in anticipating students' incorrect thinking because the errors that might be done by students were stated clearly.

Key words: mathematical thinking, mathematics teaching, planning of mathematics instruction.

GİRİŞ

Matematiksel düşünme, matematiksel kavramlar, teknikler ve süreçler kullanılarak gerçekleştirilen problem çözme etkinliğidir ve matematiksel düşünmenin temelinde keşfetme, mantıksal ilişkileri bulma ve matematiksel terimlerle ifade etme süreci bulunur (Henderson vd. 2001, 2002; Yıldırım, 2008; Mubark, 2005; MEB, 2005).

Matematiksel düşünme üç açıdan önemlidir: (1) matematiksel düşünme öğretimin önemli bir amacıdır; (2) matematiksel düşünme matematiği öğrenmenin bir yolu olarak önemlidir ve (3) matematiksel düşünme matematiği öğretmek için önemlidir (Stacey, 2006).

Matematik öğretiminin etkili bir şekilde uygulanması için öğretmenler, öğrencilerinin matematik içeriğini nasıl öğrendiklerinin ve bu içerik hakkında nasıl düşündüklerinin bilgisine yani öğrencilerinin matematiksel düşüncelerinin bilgisine sahip olmalıdırlar. Ayrıca, öğretmenler olası çözüm stratejilerini veya süreçlerini

öğrencilerin nasıl kullandığını ve öğrencilerinin sahip olabileceği olası ön kavramalarının ve kavram yanılgılarının da bilgisine sahip olmalıdırlar. Öğretmenlerin, ders esnasında öğrencilerinin düşüncelerini anlamlandırıp değerlendirmek için yöntemleri bilmesi gerektiği ve matematiksel olarak verimli tartışmalar gerçekleştirmek için öğrencilerinin düşüncelerini kullanma hakkında kararlar vermesi gerektiği konusunda görüş birliği vardır (Hughes, 2006).

Öğrencilerin matematiksel düşünme konusunda yeterli olmadıkları çeşitli araştırmalarla ortaya konulmuştur (Umay, 1992; Lutfiyya, 1998; Cai, 2003; Mubark, 2005; Duran, 2005; Yeşildere, 2006; Ovayolu, 2010). Ayrıca öğretmenlerin veya öğretmen adaylarının matematiksel düşünme konusunda ve öğrencilerin matematiksel düşüncelerine odaklanan matematik öğretimi gerçekleştirme konusundaki eksiklikleri de araştırmalarda ortaya çıkmıştır (Weiss, Pasley, Smith, Banilower ve Heck, 2003; Alkan ve Güzel, 2005; Hughes, 2006). Türkiye’de öğretmenlerin öğretimlerinde öğrencilerinin matematiksel düşüncelerine odaklanmalarını ele alan bir araştırmaya ve Ortaöğretim Matematik Öğretimi Programının (MEB, 2013) “öğrencilerin matematiksel düşünme becerisi kazanmalarını sağlamak” şeklindeki amacını öğretmenlerin nasıl gerçekleştirecekleri konusunda Türkçe bir kaynağa rastlanmamıştır. Literatürde öğretmenlere veya öğretmen adaylarına öğrencilerinin matematiksel düşüncelerine odaklanmalarının ve öğrencilerinin matematiksel düşünceleri hakkında bilgilerini arttırmalarının çeşitli yollarını göstermek için düzenlenmiş öğretim uygulamalarının, öğrencilerin matematiksel düşüncelerine odaklanmaları konusunda yol gösterici olduğu da görülmüştür (Fennema vd., 1996; Swafford vd., 1997; Barnett, 1998; Schifter, 1998; Vacc ve Bright, 1999; Crespo, 2000; Warfield, 2001; Masingila ve Doerr, 2002; Fernandez, Cannon ve Chokshi, 2003; Little, Gearhart, Curry ve Kafka, 2003; Kazemi ve Franke, 2004; Sherin ve Han, 2004; Fernandez, 2005; Hughes, 2006; Boston, 2006; Metz, 2007; Stein, Engle, Hughes ve Smith, 2008).

İncelenen araştırmalara ve ÖYEGM (2008, 2009) tarafından belirlenen öğretmen yeterliklerine dayanarak, matematik öğretmen adaylarının planladıkları öğretim etkinliklerinde öğrencilerinin matematiksel düşünme süreçlerine dikkat etmelerini sağlamak için lisans düzeyinde bir ders almaları gerektiği sonucu çıkarılmıştır. Bu sonuçtan hareketle gerçekleştirilen bu çalışmada, öğretmenlerin öğrencilerinin matematiksel düşüncelerine odaklanmalarını temel alan öğretim uygulamalarının karması olma özelliğine sahip bir öğretim olan matematiksel düşünme odaklı öğretim uygulaması planlanmıştır ve bu öğretim uygulamasının etkililiğinin araştırılması gerektiğine karar verilmiştir. Matematiksel düşünme odaklı öğretim uygulaması, öğretmen adaylarına öğrencilerinin matematiksel düşüncelerini dikkate alan dersler planlamalarında yol gösterici ve öğrencilerde matematiksel düşünmenin geliştirilmesi konusunda matematik eğitimi ve öğretmen eğitimine önemli katkısı olan bir öğretim uygulamasıdır. Matematiksel düşünme odaklı öğretim uygulamasının etkililiğinin araştırıldığı bu çalışmanın Türkiye’de matematik öğretimine farklı bir bakış açısı getirerek matematik eğitimi ve öğretmen yetiştirme alanında literatüre katkı sağlayacağı düşünülmektedir.

Araştırmanın problemi ve alt problemler

Bu araştırma matematiksel düşünme odaklı öğretim uygulamasına katılan öğretmen adaylarının yapmış oldukları planların incelenmesi ve öğretmen adaylarının yapmış oldukları planlarda öğrencilerinin hatalı çözümlerini öngörme becerilerinin belirlenmesi amacıyla gerçekleştirilmiştir. Buna göre araştırmanın problem ve alt problemleri şu şekilde ifade edilmiştir: Matematiksel düşünme odaklı öğretim uygulamasına katılan ortaöğretim matematik öğretmen adaylarının yapmış oldukları planlarda öğrencilerinin matematiksel düşüncelerini dikkate alan planlar yapma becerilerinin belirlenmesindeki öğelerden biri olan öğrencilerin hatalı çözümlerini öngörmeye nasıl bir değişim olmuştur?

Yukarıda belirtilen araştırma problemine göre araştırmada şu sorulara yanıt aranmıştır:

1. Öğretmen adaylarının matematiksel düşünme odaklı öğretim uygulaması öncesinde ve sonrasında yapmış oldukları planlarda öğrencilerin hatalı çözümlerini öngörme puanları arasında anlamlı fark var mıdır ve öğretmen adaylarının öğrencilerinin hatalı çözümlerini öngörme becerilerinde nasıl bir değişim olmuştur?
2. Öğretmen adaylarının matematiksel düşünme odaklı öğretim uygulamasından bir yarıyıl sonrasında yapmış oldukları planlardaki öğrencilerin hatalı çözümlerini öngörme puanları ile öğretim uygulaması sonrasındaki planların öğrencilerin hatalı çözümlerini öngörme puanları arasında anlamlı fark var mıdır? Öğrencilerin hatalı çözümlerini öngörme açısından matematiksel düşünme odaklı öğretim uygulamasının kalıcılığı nasıldır?

Teorik çerçeve

Araştırmaya, Hughes (2006) tarafından belirlenen teorik çerçeve yön vermiştir. Teorik çerçeve, öğretimde öğrencilerin matematiksel düşüncelerine dikkat etmede önemli olan dört öğeye sahiptir (Hughes, 2006). Çerçevadaki öğeler (1) dersin matematiksel amacını belirleme; (2) öğrencilerin doğru çözümlerini ve olası kavram yanılgılarını veya hatalı çözümlerini öngörme; (3) öğrenciler çalışırken anlayışlarını değerlendirip ilerletecek sorular belirleme; (4) öğrenci düşünmesine dayandırılan ve dersteki matematiksel anlayışları

belirginleştirecek tartışma düzenleme şeklindedir. Teorik çerçeve, öğretmenlere veya öğretmen adaylarına öğrenci düşünmesine nasıl odaklanılacağı konusunda fikir sunmakta ve öğrenci düşünmesine odaklı etkinliklerden öğretmenlerin neler öğrendiğini değerlendirme için yol göstermektedir (Hughes, 2006). Matematiksel düşünme odaklı öğretim uygulamasında bu teorik çerçevenin öğeleri vurgulanmış ve çalışmaya katılan öğretmen adaylarının öğrencilerinin matematiksel düşüncelerine odaklanan planlar yapma becerilerini belirlemek için bu teorik çerçeve kullanılmıştır.

YÖNTEM

Araştırmanın Modeli

Öğrencilerinin hatalı çözümlerini öngörme becerilerinin belirlenmesi amacıyla öğretmen adaylarının yapmış oldukları planlar incelenmiştir. Planların incelenmesi söz konusu olduğundan nitel veri toplama yöntemlerinden doküman incelemesi kullanılmıştır (Yıldırım ve Şimşek, 2006). Katıldıkları öğretim uygulaması öncesinde, sonrasında ve bir yarıyıl sonrasında öğretmen adaylarının yapmış oldukları planlarda öğrencilerin hatalı çözümlerini öngörme ögesinde aldıkları puanlar arasında anlamlı fark olup olmadığını belirlemek şeklindeki nicel araştırma amacını gerçekleştirmek için deneysel araştırma desenlerinden tekrarlı ölçümler deseni kullanılmıştır (Büyüköztürk, Çakmak, Akgün, Karadeniz ve Demirel, 2008). Buna göre çalışmada nicel araştırma amacıyla deneysel araştırma desenlerinden tekrarlı ölçümler deseni ve nitel veri toplama yöntemlerinden doküman incelemesi kullanıldığı için araştırmanın karma araştırma desenine sahiptir (Johnson ve Christensen, 2004; Johnson ve Onwuegbuzie, 2004).

Katılımcılar

Araştırmanın katılımcıları, Balıkesir Üniversitesi Necatibey Eğitim Fakültesi OFMAE Bölümü, Matematik Eğitimi Anabilim Dalı 4. sınıf öğrencilerinden oluşan bir gruptur. 2010–2011 eğitim öğretim yılı bahar yarıyılında Problem Kurma ve Çözme adlı derse devam eden 40 öğretmen adayından meydana gelen grup, “kolay ulaşılabilir durum” örnekleme (Yıldırım ve Şimşek, 2006) ile oluşturulmuştur. Araştırmaya katılan öğretmen adaylarının 21’i kız, 19’u erkektir.

Verilerin toplanması

Bu çalışmada, 2010–2011 eğitim öğretim yılı bahar yarıyılında haftada 4 saat olmak üzere 12 haftalık bir sürede uygulanan matematiksel düşünme odaklı öğretim gerçekleştirilmiştir. Matematiksel düşünme odaklı öğretim uygulaması, öğrencilerin matematiksel düşüncelerine odaklanan öğretim uygulamalarını içeren çeşitli çalışmalar (Boston, 2006; Hughes, 2006; Metz, 2007) incelenerek oluşturulmuştur. Matematiksel düşünme odaklı öğretim uygulaması, öğretmen adaylarının matematik öğretimi ile ilgili örnek olayları, videoya çekilmiş bir matematik dersini, sınıf tartışmalarını, örnek planları incelemelerini içeren bir uygulamadır. Öğretim uygulaması esnasında öğretmen adaylarına, planlama yapmaları için düzenlenmiş bir araç olan Ders Boyunca Düşünme Protokolü (DBDP) (Hughes ve Smith, 2004; Hughes, 2006; Smith, Bill ve Hughes, 2008) tanıtılmıştır. Araştırmaya katılan öğretmen adaylarından bu aracı kullanarak matematiksel düşünme odaklı öğretim uygulamasının planında belirlenmiş matematiksel görevlere ve kendi belirledikleri matematiksel görevlere dayalı olarak bireysel ve işbirlikli planlar yapmaları istenmiştir. Öğretmen adayları farklı görevlere dayanarak hazırlanmış örnek planları inceleyerek bireysel olarak yapmış oldukları planlar üzerinde yansıtılarda bulunmuşlar; işbirlikli olarak yaptıkları planlar için sınıflarında mikro öğretim uygulaması yapmışlardır. Matematiksel düşünme odaklı öğretim uygulaması öncesinde ve sonrasında katılımcı öğretmen adaylarına veri toplamak amacıyla üst düzey düşünme süreçlerini içeren bir problem olan “Grafiklerden Açıklamalara [GA]” problemi (Friel, vd., 2001) (EK A) verilerek bu problem çerçevesinde planlar yapmaları istenmiştir. Öğretim uygulamasının kalıcılığını belirlemek için 2011–2012 eğitim öğretim yılının (öğretim uygulamasının gerçekleştiği öğretim yılını izleyen öğretim yılının) güz yarıyılı sonunda öğretmen adaylarının aynı problemle tekrar planlar yapmaları istenmiştir.

Verilerin analizi

Araştırmada öğretmen adaylarının yapmış oldukları planların analizi söz konusu olduğundan nitel veri analizi yöntemlerinden betimsel analiz kullanılmıştır. Betimsel analizi gerçekleştirmek için araştırmanın dayandığı teorik çerçeveye uygun olarak Hughes (2006) tarafından geliştirilmiş bir araç olan Ders Planlama Öğeleri Rubriğinde (Hughes, 2006) yer alan öğeler tema olarak kullanılmış ve katılımcıların yapmış oldukları planlar “GA” problemine özgü olacak şekilde kodlanmıştır. Analiz sonucunda elde edilen bulgular, katılımcıların planlarından alıntılar kullanılarak desteklenmiş ve yorumlanmıştır.

Ders Planlama Öğeleri Rubriğinde, ders planlama sürecinde öğrencilerin matematiksel düşüncelerine

odaklanmanın dört temel ögesi; (1) dersin matematiksel amacını belirleme, (2) öğrencilerin doğru çözümlerini ve hatalı çözümlerini öngörme, (3) öğrenci düşünmesini değerlendirip ilerletecek sorular sorma ve (4) öğrencilerin düşünmelerine dayandırılan tartışma ve dersteki matematiksel fikirleri belirginleştirecek tartışma düzenleme olarak belirtilmiştir. Rubriğin amacı öğretmen adaylarının yapmış oldukları planların bu öğelere göre açık ve anlaşılır olup olmadığını belirlemek, dolayısı ile öğretmen adaylarının planladıkları derslerde öğrencilerin matematiksel düşünmelerini dikkate alma derecelerini ortaya çıkarmaktır. Bu nedenle rubrikle öğretmen adaylarının yapmış oldukları önerilerin belirgin bir şekilde ifade edilip edilmemesi değerlendirilmiştir (Hughes, 2006). Bu çalışmada Ders Planlama Öğeleri Rubriğindeki öğrencilerin hatalı çözümlerini öngörme ögesine odaklanılmıştır. Öğrencilerin hatalı çözümlerini öngörme ögesi, öğrencilerin görevi çözerken karşılaşılabilecekleri zorlukların, yapabilecekleri hataların ve sahip olabilecekleri kavram yanlışlarının öngörülmesini ölçmeye yönelik bir ögedir ve dört derecelik bir ölçekle kodlanmıştır (0, 1, 2 ya da 3 puan). Öğretmen, öğrencilerin problemi çözerken karşılaşılabilecekleri sorunların ve kavram yanlışlarının çoğunu tanımlamaya çalışmışsa planlar, öğrencilerin hatalı çözümlerini öngörme ögesine göre 3 puan olarak kodlanmıştır. Öğrencilerin problem üzerinde yanlış düşünebilme yollarının çoğunun tanımlanmaya çalışıldığı gösterilmemesi 2 puan olarak kodlanmıştır. Öğrencilerin problem üzerinde yanlış düşünebilme yolları belirsiz bir şekilde tanımlanması 1 puan olarak kodlanmıştır. Öğretmen öğrencilerin problem üzerinde yanlış düşünebilme yollarını öngörme konusunda herhangi bir çaba göstermemişse planlar, öğrencilerin hatalı çözümlerini öngörme ögesinde 0 puan olarak kodlanmıştır (Hughes, 2006).

Öğretmen adaylarının matematiksel düşünme odaklı öğretim uygulaması öncesinde, sonrasında ve bir yarıyıl sonrasında yapmış oldukları planların puanlarına SPSS 12.0 programı ile normallik testi yapılmış ve verilerin normal dağılım göstermediği görülmüştür. Bu nedenle katıldıkları öğretim uygulaması öncesinde, sonrasında ve bir yarıyıl sonrasında öğretmen adaylarının yapmış oldukları planlarda öğrencilerin hatalı çözümlerini öngörme puanları arasında anlamlı fark olup olmadığını belirlemek için nicel veri analizi yöntemlerinden Wilcoxon işaretli sıralar testi yapılmıştır (Büyüköztürk, 2003).

Verilerin geçerliği ve güvenilirliği

Matematiksel düşünme odaklı öğretim uygulamasının öğretmen adaylarının matematik öğretimini planlama becerilerine etkisini belirlemek için öğretmen adaylarının yapmış oldukları planlar araştırmaya yön veren teorik çerçeveye uyumlu Ders Planlama Öğeleri Rubriği ile incelenerek kodlanmıştır. Bu da verilerin anlamlı bir şekilde tanımlanmasını ve bulguların kendi içinde tutarlı olmasını sağlamıştır. Planlar analiz edilirken sadece rubrik puanı kullanılmamış ayrıca planlardan alıntılar yapılarak analizler ayrıntılandırılmıştır (iç geçerlik). Araştırmada, katılımcılar 40 kişilik bir grup olduğundan örneklemin genellemeye izin verecek ölçüde çeşitlendirilmiş olduğu ifade edilebilir. Araştırma ortam ve süreçleri ayrıntılı olarak tanımlanmış ve araştırma bulguları ile sonuçları araştırmaya yön veren teorik çerçeveye göre ayrıntılı olarak açıklanmıştır. Bu nedenle araştırma bulguları benzer ortamlarda test edilebilir (dış geçerlik) (Yıldırım ve Şimşek, 2006; Miles ve Huberman, 1994).

Güvenirlik ölçütlerinden biri olan verilerin analizinde kodlama kontrolünün yapılması ve kodlama uyuşumunun yeterli olması ölçütünü gerçekleştirmek için matematiksel düşünme odaklı öğretim uygulaması öncesinde ve sonrasında öğretmen adaylarının yapmış oldukları planlardan rasgele seçilen 10 tanesinin Ders Planlama Öğeleri Rubriği ile incelemesi ikinci araştırmacı tarafından da yapılmıştır. Kodlayıcılar arası uyuşum şu formülle (Miles ve Huberman, 1994) hesaplanmıştır: $Güvenirlik = \frac{\text{uyuşum olan kategorilerin sayısı}}{\text{uyuşum olan ve olmayan kategorilerin toplam sayısı}}$. Buna göre, $Güvenirlik = \frac{48}{60} = 0,80$ olarak hesaplanmıştır. İki farklı kodlayıcının uyuşumu için %70 üzerindeki değerlerin kodlayıcılar arası güvenilirlik için yeterli olduğu ifade edilmiştir (Miles ve Huberman, 1994). Tüm verilerin kodlamasını gerçekleştiren araştırmacının kodlamalarının güvenilirliği için, rastgele seçilen 10 öğretmen adayının planı öğretim uygulaması sonrasında yapılan planların analizinden 4 ay sonra aynı araştırmacı tarafından tekrar kodlanmış ve yukarıdaki formül ile $Güvenirlik = \frac{59}{60} = 0,98$ olarak hesaplanmıştır. İç tutarlık katsayısı anlamına gelen bu oranın %90 civarında olmasının yeterli olduğu ifade edilmiştir (Miles ve Huberman, 1994).

BULGULAR

Bu bölümde matematiksel düşünme odaklı öğretim uygulaması öncesinde, sonrasında ve bir yarıyıl sonrasında "GA" problemi için öğretmen adaylarının yapmış oldukları planların Ders Planlama Öğeleri Rubriğindeki öğrencilerin hatalı çözümlerini öngörme ögesine göre verilen puanların dağılımına ve karşılaştırmalarına yer verilerek planlardan alıntılarla yorumlanmıştır.

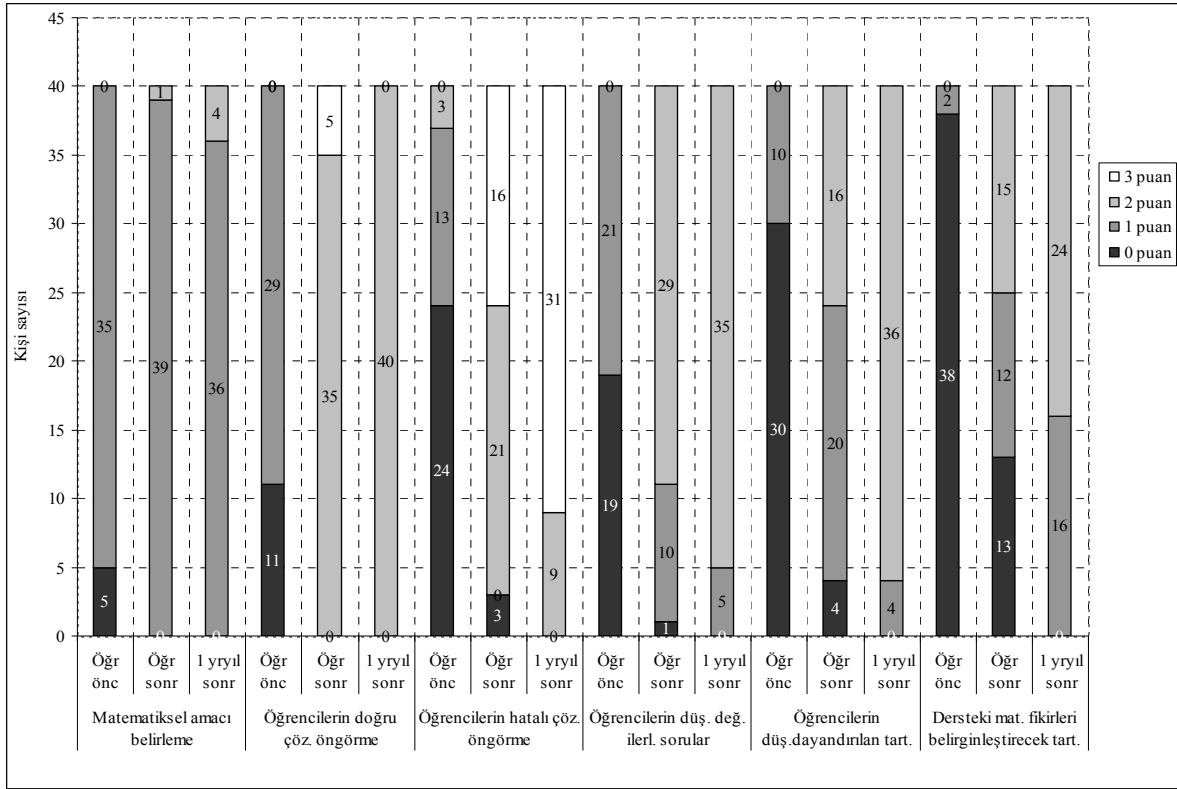

Şekil 1. “GA” Problemi Çerçevesinde Yapılan Planların Öğelere Göre Puanları

Öğretim uygulaması öncesinde “GA” problemi için yaptıkları planlarda öğrencilerin hatalı çözümlerini öngörme ögesinde tam puan (3 puan) alan öğretmen adayı yoktur. Bu ögede 11 öğretmen adayının planı 1 puan; 3 öğretmen adayının planı 2 puan olarak kodlanmıştır (Şekil 1). Planları 1 puan olarak kodlanan öğretmen adayları “yanlış cevaplarda ve düşüncelerde hemen dönüt verilmeli ve düzeltme yapılmalı” (19. öğretmen adayı) örneğinde olduğu gibi öğrencilerinin yapabilecekleri hataları belirli bir şekilde ifade etmemişlerdir. Bu ögede planları 2 puan olarak kodlanan öğretmen adayları ise “öğrenci sıfırın altında kalan bölgeyi tanımlayamaz” (2. problem için belirtilmiştir) (17. öğretmen adayı) örneğinde olduğu gibi sadece bir hata belirtmişlerdir. Öğretim uygulaması öncesinde “GA” problemi için yapılan planlardan elde edilen bulgulara göre öğretmen adaylarının öğrencilerin hatalı çözümlerini öngörme ögesinde başarısız olduğu belirtilebilir.

Öğretim uygulaması sonrasında “GA” problemi için yapılan planlarda öğrencilerin problem üzerinde yanlış düşünebilme yolları tüm öğretmen adayları tarafından açık bir şekilde ifade edildiği için öğrencilerin hatalı çözümlerini öngörme ögesinde 1 puan alan öğretmen adayı yoktur. Bu ögede 21 öğretmen adayının planı 2 puan; 16 öğretmen adayının planı 3 puan (tam puan) almıştır (Şekil 1). Planı 2 puan olarak kodlanan öğretmen adayları her bir problem için öğrencilerinin yapabileceği birer hata öngörerek ifade etmiştir. Bu ögede planına 3 puan verilen öğretmen adayları 6 ile 9 arasında değişen sayılarda öğrenci hatası ifade etmişlerdir. Örneğin bu öge için planı 3 puan olarak kodlanan 28. öğretmen adayı öğrencilerinin yapabilecekleri hataları, 1. problem için “Ali’nin yarışa geç başlamasını göz ardı edebilirler. Yarışın kesişim noktasından önce bittiğini düşünebilirler.

Ali’nin doğrusunun eğimini bulurken $\frac{y}{x-3}$ yerine $\frac{y}{x}$ alabilirler.”, 2. problem için “Doğrunun x eksenini kesmesini zarar etme olarak algılayabilirler. Grafikte y eksenine paralel kısmı satıcıya veya kiraya verilen para olarak düşünebilirler.”, 3. problem için “x eksenine paralel kısımları göz ardı edebilir.” 4. problem için “Ayşe ile Fatma’nın havuzda karşı kıyıya kadar gidip orada yarışı tamamladığını düşünebilirler. İlk yarıda hızlı olanın yarışı kazandığını düşünebilirler.” şeklinde açıkça ifade etmiştir ve hataların çoğunu ifade etmek için bir çaba göstermiştir. Öğretim uygulaması sonrasında “GA” problemi için yapılan planlardan elde edilen bulgulara göre öğretmen adaylarının öğrencilerin hatalı çözümlerini öngörme ögesindeki başarılarının oldukça yüksek olduğu söylenebilir.

Öğretim uygulamasından bir yarıyıl sonra “GA” problemleri için yaptıkları planlarda öğrencilerinin hatalı çözümlerini öngörme ögesinde, öğrencilerinin problem üzerinde yanlış düşünebilme yollarını açık bir şekilde ifade ettiği için 9 öğretmen adayı 2 puan; 31 öğretmen adayı 3 puan (tam puan) almıştır (Şekil 1). 2 puan alan öğretmen adayları her bir problem için öğrencilerinin yapabileceği birer hata ifade etmişlerdir. Bu ögede 3 puan alan öğretmen adayları 6 ile 15 arasında değişen sayıda öğrencilerinin yapabileceğini öngördükleri hataları ifade etmişlerdir. Öğrencilerin hatalı çözümlerini öngörme ögesinde 3 puan verilen öğretmen adayları, 1. problem için

“grafğin kesim noktasında Ali ile babasının yan yana geldiğini anlamayabilir. Ali yarışa geç başladığı için yarışı geç bitireceğini düşünebilir.”, 2. problem için “Doğrunun sıfırın altında olmasının sebebinin maliyet olduğunu düşünemeyebilirler. Limon(ata) satmaya başlamadan limonatacının zarar ettiğini anlamayabilirler. Doğrunun x eksenini kestiği noktanın (noktada) kar elde etmeye başladığını anlamayabilirler.”, 3. problem için “bayrağın hareketini açıklayamayabilirler. Bayrağın yükselmesinin zaman içinde değişmemesini dikkate almayabilirler” 4. problem için “İlk 30 metreyi Ayşe daha önce bitirdiği için yarışı Ayşe'nin kazanacağını düşünebilirler.” (24. Öğretmen adayı) örneğindeki gibi öğrencilerinin yapabilecekleri hataları açıkça ifade ederek hataların çoğunu ifade etmek için bir çaba göstermişlerdir. Öğretim uygulamasından bir yarıyıl sonra “GA” problemi için yapılan planlardan elde edilen bulgulara göre öğretmen adaylarının öğrencilerin hatalı çözümlerini öngörme ögesindeki başarılarının çok yüksek olduğu söylenebilir.

Öğretmen adaylarının öğretim uygulaması öncesinde ve sonrasında “GA” problemi çerçevesinde yaptıkları planların öğrencilerin hatalı çözümlerini öngörme ögesindeki puanlarının öğretim uygulaması öncesinden sonrasına anlamlı farklılık gösterip göstermediğine ilişkin Wilcoxon işaretli sıralar testi sonuçları Tablo 1’de verilmiştir.

Tablo 1. “GA” Planlarında Öğrencilerin Hatalı Çözümlerini Öngörme Puanlarının Wilcoxon İşaretli Sıralar Testi Sonuçları

Sontest-Öntest	n	Sıra Ortalaması	Sıra Toplamı	z	p
Negatif Sıra	0	0,00	0,00	5,34*	0,000
Pozitif Sıra	36	18,50	666,00		
Eşit	4				

* Negatif sıralar temeline dayalı

Tablo 1’de gösterilen test sonuçlarına göre araştırmaya katılan öğretmen adaylarının öğretim uygulaması öncesinde ve sonrasında yaptıkları planların öğrencilerin hatalı çözümlerini öngörme ögesinde aldıkları puanlar arasında anlamlı bir fark vardır ($z=5,34$; $p<0,05$). Fark puanların sıra toplamaları dikkate alındığında, gözlenen bu fark pozitif sıralar lehindedir. Başka bir deyişle öğretim uygulamasından sonraki planların öğrencilerin hatalı çözümlerini öngörme ögesindeki puanları lehine anlamlı farklılık söz konusudur. Ayrıca öğrencilerin hatalı çözümlerini öngörme ögesinde 4 öğretmen adayının öğretim uygulaması öncesinde ve sonrasında planlarının puanları eşit iken, 36 öğretmen adayının öğretim uygulaması sonrasında öncesine göre planlarının puanları daha yüksektir (Tablo 1). Bu bulgulara dayanarak matematiksel düşünme odaklı öğretim uygulamasının öğretmen adaylarının planladıkları derste öğrencilerinin hatalı çözümlerini öngörmelerinde etkili olduğu ifade edilebilir. Öğretmen adayları öğretim uygulaması öncesinde yaptıkları planlarda öğrencilerinin problem üzerinde yanlış düşünebilme yollarını belirli bir şekilde ifade etmemişlerdir; ifade ettikleri hatalar sınırlı kalmıştır. Öğretim uygulaması sonrasındaki planlarda ise öğrencilerinin yanlış düşünebilme yolları daha ayrıntılı bir şekilde ifade edilmiştir. 36 öğretmen adayının öğretim uygulaması sonrasındaki planlarında öğrencilerin hatalı çözümlerini öngörme ögesindeki puanlarını arttırmış olmasının nedeninin, matematiksel düşünme odaklı öğretim uygulamasında, öğrencilerin yapabilecekleri hataların, düşebilecekleri kavram yanlışlarının öngörülüp planlamada dikkate alınması gerektiğinin vurgulanması ve öğrencilerin yapabilecekleri hataları, düşebilecekleri kavram yanlışlarını içeren örnek planların incelemeleri için öğretmen adaylarına sunulması olduğu söylenebilir. Hughes (2006)’in çalışmasına katılan öğretmen adayları da öğrencilerin hatalı çözümlerini öngörme ögesinde ilerleme göstermişlerdir ancak öğretim uygulaması öncesinde ve sonrasında düşük puanlar alarak en az ilerlemeyi bu ögede göstermişlerdir. Öğretmenlerin öğrencilerinin matematiksel düşünmelerine odaklanmalarını temel alan öğretim uygulamalarını ele alan başka çalışmalarda da öğretmenlerin derslerinde öğrencilerinin karşılaştıkları zorluklara, yaptıkları hatalara odaklandıkları görülmüştür (Barnett, 1998; Masingila ve Doerr, 2002; Sherin ve Han, 2004). Bunlara dayanarak bu çalışmada gerçekleştirilen matematiksel düşünme odaklı öğretim uygulamasının benzer öğretim uygulamalarında olduğu gibi öğretmen adaylarının planladıkları derste öğrencilerinin hatalı çözümlerini öngörmelerinde etkili olduğu ifade edilebilir.

Tablo 2. “GA” Planlarındaki Puanların Wilcoxon İşaretli Sıralar Testi Sonuçları

Sontest-Öntest	n	Sıra Ortalaması	Sıra Toplamı	z	p
Negatif Sıra	0	0,00	0,00	3,753*	0,000
Pozitif Sıra	16	8,50	136,00		
Eşit	24				

* Negatif sıralar temeline dayalı

Öğretim uygulaması sonrasında ve öğretim uygulamasından bir yarıyıl sonra yapılan planlarda öğrencilerin

hatalı çözümlerini öngörme ögesindeki puanlar arasında anlamlı bir fark olduğu ortaya çıkmıştır ($z=3,753;p<0,05$). Fark puanlarının sıra toplamları dikkate alındığında, gözlenen fark pozitif sıralar lehindedir. Buna göre öğretmen adaylarının öğretim uygulamasından bir yarıyıl sonra yapmış oldukları planlar, öğrencilerin hatalı çözümlerini öngörme ögesinde öğretim uygulaması sonrasındaki planlardan daha fazla puan almıştır (Tablo 2). Bu bulgu çalışmaya katılan öğretmen adaylarının hatalı çözümlerini öngörme ögesindeki kalıcılık puanlarının yüksek olduğu şeklinde yorumlanabilir.

Tartışma

Bu çalışmada matematiksel düşünme odaklı öğretim uygulaması gerçekleştirilmiştir. Uygulamaya katılan öğretmen adayları matematiksel görevleri, bir matematik problemi hakkında yapılmış sınıf tartışmasını, matematik öğretimi ile ilgili örnek olayları ve bir matematik dersinin video kaydını incelemişlerdir. Ayrıca inceledikleri matematiksel görevleri, sınıf tartışmasına konu olan problemi, örnek olaylardaki problemleri, video kaydındaki problemleri çözmüşler ve öğrencilerin bu problemleri doğru ve yanlış bir şekilde çözebilme yolları hakkında tartışmışlardır.

Öğretim uygulamasına katılan öğretmen adaylarının matematiksel görevleri incelemeleri, derslerde kullanacakları görevleri sınıflandırmalarını ve görevleri dersin amacına uygun olarak seçmelerini; bir matematik problemi hakkında yapılmış sınıf tartışmasını incelemeleri, belirtilen matematiksel amaçlara yönelik olarak öğrencilere yöneltilebilecek soruları belirlemelerini ve öğretmen sorularını değerlendirmelerini sağlamıştır. Çalışmaya katılan öğretmen adayları, örnek olayları ve bir matematik dersi videosunu inceleyerek örnek olaylarla videodaki öğretmenlerin ve öğrencilerin dersteki hareketlerine odaklanmışlardır. Öğretim uygulamasında matematiksel görevleri ve problemleri çözerek bu problemler hakkında tartışan öğretmen adayları, öğrencilerin bir problemi çözmek için kullanabilecekleri stratejileri ve yaşayabilecekleri zorlukları dikkate almışlardır. Buna göre matematiksel düşünme odaklı öğretim uygulamasına katılmak öğretmen adaylarının, öğretmenlerin öğrencilerinin matematiksel düşünmelerine odaklanmasını temel alan çalışmalarda bulunan şu özellikleri geliştirmelerine olanak vermiştir: öğrencilerin bir problemi çözerken kullanabilecekleri çeşitli yolları öngörmek (Fennema vd., 1996; Barnett, 1998; Stein, 2008; Lee, 2006); öğrencilerin olası yanlış yanıtlarını veya kavram yanılgılarını öngörmek (Masingila ve Doerr, 2002; Little vd., 2003; Sherin ve Han, 2004; Hughes, 2006); öğrencilere kendi düşüncelerini anlamlandırmaları için sorular sormak (Fennema vd., 1996; Vacc ve Bright, 1999; Masingila ve Doerr, 2002; Kazemi ve Franke, 2004; Metz, 2007); öğrencilerin matematiksel düşünmelerini ilerletmek için sorular sormak (Fennema vd., 1996; Vacc ve Bright, 1999; Masingila ve Doerr, 2002; Kazemi ve Franke, 2004; Metz, 2007).

Matematiksel düşünme odaklı öğretim uygulamasına katılan öğretmen adayları kendilerinin belirledikleri matematiksel görevlere dayalı olarak işbirlikli planlar da yapmışlardır. Öğretim uygulamasının son üç haftasında yaptıkları bu planları mikro öğretim yöntemi ile sınıflarında uygulamışlardır. Bu uygulamalar, öğretmen adaylarına öğrenmiş oldukları anlayış ve planlama yöntemini kullanarak yaptıkları planların pratikte nasıl uygulandığını görme fırsatını vermiştir. Bu da matematiksel düşünme odaklı öğretim uygulamasının, öğretmen adaylarının uygulamada yer alan etkinliklere aktif olarak katılmasını gerektiren uygulama temelli bir öğretim özelliğine sahip olmasını sağlamıştır. Matematiksel düşünme odaklı öğretim uygulamasının uygulama temelli olması, uygulamanın en güçlü yönüdür. Bu nedenle matematiksel düşünme odaklı öğretim uygulaması, benzer öğretim uygulamalarında (Boston, 2006; Hughes, 2006; Metz, 2007) olduğu gibi çalışmaya katılan öğretmen adaylarının öğrencilerinin matematiksel düşünmelerini dikkate alan planlar yapma becerilerinde gelişmeye neden olmuştur. Üstelik öğretim uygulamasından bir yarıyıl sonra öğretmen adayları tarafından yapılan planlar, matematiksel düşünme odaklı öğretim uygulamasının kalıcılığının da oldukça yüksek olduğunu göstermiştir.

Sahip olduğu özellikler göz önüne alındığında matematiksel düşünme odaklı öğretim uygulaması, öğretmen adaylarına öğrencilerinin matematiksel düşünmelerini dikkate alan dersler planlamalarında yol gösterici ve öğrencilerde matematiksel düşünmenin geliştirilmesi konusunda matematik eğitimi ve öğretmen yetiştirme alanlarına önemli katkısı olan bir öğretim uygulamasıdır. Bu çalışma ortaya koymuştur ki uygulanan öğretim uygulamasına katılan öğretmen adayları, öğretmenlerin veya öğretmen adaylarının öğrencilerinin matematiksel düşünmelerine odaklanması ile ilgili çalışmalarda yer alan özelliklerden biri olan öğrencilerin hatalı çözümlerini öngörme özelliğine sahip planlar yapma konusunda başarılı olmuşlardır. Bu durum literatürde yer alan öğretmenlerin veya öğretmen adaylarının öğrencilerinin matematiksel düşünmelerine odaklanmalarını sağlamak için geliştirilmiş uygulamalardan elde edilen sonuçlarla paralellik göstermektedir (Hughes, 2006; Metz, 2007). Buna göre gerçekleştirilen öğretim uygulamasının amacına ulaştığı ifade edilebilir.

SONUÇ

Geleneksel öğretim yöntemiyle işlenen sıradan matematik dersleri, öğrencilerin sadece hesaplama, sınıflandırma ve tanımlama süreçlerinde ustalaşmalarını sağladığından öğrencilerin matematiksel düşünme becerilerini geliştirmede yetersiz kalır. Öğrencilere matematiksel akıl yürütme, iletişim kurma, tahminde bulunma,

ispatlama, kavramsal düşünceleri geliştirme ve öğrendikleri yöntemler ile bu yöntemlerin neden işe yaradığını gösteren kavramlar arasında bağ kurma fırsatlarının sunulduğu dersler, öğrencilerin matematiksel düşünme becerilerinin geliştirilmesine katkıda bulunur. Bu özellikleri taşıyan derslerin planlanıp uygulanması konusunda matematik eğitimcilerine, öğretmenlere veya öğretmen adaylarına yol gösterici bir uygulama olduğu için matematiksel düşünme odaklı öğretim uygulaması öğretmen eğitimine önemli bir katkı sağlamıştır.

Matematiksel düşünme odaklı öğretim uygulamasının etkililiğinin araştırıldığı bu çalışma Türkiye’de matematik öğretimine farklı bir bakış açısı getirerek matematik eğitimi ve öğretmen yetiştirme alanında literatüre katkı sağlamıştır.

Matematiksel düşünme odaklı öğretim uygulamasında yer alan etkinlikler, vurgulanan özellikler ve incelenen örnek olaylar ile planlar, uygulamaya katılan öğretmen adaylarının, araştırmanın dayandığı teorik çerçevede ve literatürde belirtilen öğretmenlerin öğrencilerinin matematiksel düşüncelerini dikkate alan dersler planlamaları için gereken özellikleri taşıyan planlar yapmada başarılı olmalarını sağlamıştır.

Öğretmenlerin öğrencilerinin matematiksel düşüncelerini dikkate alan dersler planlamaları için gereken özellikler, öğrencilerin ders boyunca geliştireceği matematiksel kavramları anlayarak bu kavramlara yönelik olarak anlamları oluşturup bağlantıları keşfetmelerini sağlayacak amaçları belirlemek, öğrencilerin bir problemi çözerken kullanabilecekleri çeşitli yolları öngörmek; öğrencilerin olası yanlış yanıtlarını veya kavram yanlışlarını öngörmek; öğrencilere kendi düşüncelerini anlamlandırmaları için sorular sormak; öğrencilerin matematiksel düşüncelerini ilerletmek için sorular sormak şeklindedir. Buna göre matematiksel düşünme odaklı öğretim uygulamasına katılan öğretmen adaylarının öğretmen olduklarında öğrencilerinin matematiksel düşüncelerini geliştirecek dersler planlamalarında onlara yol gösterecek bir anlayış geliştirmiş oldukları sonucu çıkarılabilir.

ÖNERİLER

Öğrencilerinin matematiksel düşüncelerini geliştirmek isteyen öğretmenler veya öğretmen adayları, bilişsel gereklilik düzeyi yüksek olan problemler seçerek planlama yapmalıdırlar. Planlama yaparken öncelikle öğrencilerin ders boyunca geliştireceği matematiksel kavramları anlamalı ve öğrencilerin bu kavramlara yönelik olarak anlamları oluşturup bağlantıları keşfetmelerini sağlayacak amaçları belirlemelidirler. Bu amaçlara ulaşmak için öğrencilerin bir problemi çözerken kullanabilecekleri çeşitli yolları ve verebilecekleri olası yanlış yanıtları veya düşebilecekleri kavram yanlışlarını öngörmek planlarında ifade etmelidirler. Daha sonra öğrencilerin matematiksel düşüncelerini değerlendirip ilerletmek için soru sormayı planlamalıdırlar. Ayrıca kendi düşüncelerini anlamlandırmaları ve dersteki matematiksel fikirleri belirginleştirmeleri için öğrencilere sorular sorarak bütün sınıfın katıldığı tartışma düzenlemeyi de planlamalıdırlar.

Öğretmenlerin veya öğretmen adaylarının planladıkları öğretim etkinliklerinde öğrencilerinin matematiksel düşünme süreçlerinin gelişimine dikkat etmelerini sağlamak için bu çalışmada ele alınan matematiksel düşünme odaklı öğretim uygulamasına benzer uygulamalar yapılması gerekir. Benzer öğretim uygulamalarında öğretmenlerin veya öğretmen adaylarının öğrencilerinin matematiksel düşüncelerine odaklanmalarını sağlamak için matematiksel görevleri, matematik problemleri hakkında yapılmış sınıf tartışmalarını, matematik öğretimi ile ilgili örnek olayları ve matematik dersi uygulamalarının video kayıtlarını incelemeleri sağlanmalıdır. İncelenen matematiksel görevler ve sınıf tartışmalarındaki, örnek olaylardaki, video kayıtlarındaki problemler uygulamanın katılımcısı olan öğretmenler veya öğretmen adayları tarafından çözülmelidir. Ayrıca öğrencilerin bu problemleri doğru ve yanlış bir şekilde çözebilme yolları hakkında tartışılmalıdır.

Bu çalışmada gerçekleştirilen matematiksel düşünme odaklı öğretim daha küçük bir katılımcı grubuna (15–20 öğretmen adayı) uygulanarak ve veri toplamak için bu çalışmada kullanılan problemlerden farklı problemler kullanılarak tekrarlanabilir.

Bu araştırma başka bir öğretmen adayı grubu örneğin ilköğretim matematik öğretmenliği bölümündeki öğretmen adayları veya sınıf öğretmeni adayları ile matematiksel düşünme odaklı öğretim uygulaması gerçekleştirilerek tekrarlanabilir.

Matematiksel düşünme odaklı öğretim uygulaması görev yapan matematik öğretmenlerine hizmet içi eğitim şeklinde uygulanarak ulaşılabilecek sonuçlar araştırılabilir.

Matematiksel düşünme odaklı öğretim uygulamasına katılmış olan öğretmen adayları, gerek uygulamanın yapıldığı yarıyılı da gerekse uygulamadan sonra aldıkları derslerde yüksek düzey bilişsel gerekliliklere sahip matematiksel görevler veya problemleri incelemişler ve çözmüşlerdir. Bu şekilde problem çözmüş olmaları öğretmen adaylarının matematiksel düşüncelerini geliştirmiş olabilir. Bu nedenle yapılacak benzer bir çalışmada öğretmen adaylarının matematiksel düşünme becerilerinin gelişimi de araştırılabilir.

Matematiksel düşünme odaklı öğretim uygulamasına katılan öğretmen adaylarının veya öğretmenlerin, öğrencilerinin matematiksel düşüncelerine odaklanan planlarını uyguladıkları gerçek sınıf ortamındaki öğretimleri incelenebilir. Öğretmen adaylarının veya öğretmenlerin gerçek sınıf ortamındaki öğretim uygulamalarının incelenmesi öğretimin etkililiğinin belirlenmesinde önemli bir etken olacaktır.

KAYNAKLAR

- Alkan, H. ve Altun, M. (1998). *Matematik Öğretimi*. Eskişehir: T.C. Anadolu Üniversitesi Yayınları No: 1072, Açıköğretim Fakültesi Yayınları No: 591.
- Barnett, C. (1998). Mathematics Teaching Cases as a Catalyst for Informed Strategic Inquiry. *Teaching and Teacher Education*, 14(1), 81–93.
- Boston, M. D. (2006). Developing Secondary Mathematics Teachers' Knowledge of and Capacity to Implement Instructional Tasks with High Level Cognitive Demands. Unpublished Ph.D. Thesis, *University of Pittsburgh, School of Education, Department of Instruction and Learning*, Pittsburgh.
- Büyüköztürk, Ş. (2003). *Sosyal Bilimler İçin Veri Analizi El Kitabı*. Ankara: Pegem Akademi Yay.
- Büyüköztürk, Ş., Çakmak, E. K., Akgün, Ö. E., Karadeniz, Ş. ve Demirel, F. (2008). *Bilimsel Araştırma Yöntemleri*. Ankara: Pegem Akademi Yay.
- Cai, J. (2003). Singaporean Students' Mathematical Thinking in Problem Solving and Problem Posing: an Exploratory Study. *International Journal of Mathematics Education in Science and Technology*, 34(5), 719–737.
- Crespo, S. (2000). Seeing More Than Right and Wrong Answers: Prospective Teachers' Interpretations of Students' Mathematical Work. *Journal of Mathematics Teacher Education*, 3(2), 155–181.
- Duran, N (2005). Matematiksel Düşünme Becerilerine İlişkin Bir Araştırma. Yayınlanmamış Yüksek Lisans Tezi, *Hacettepe Üniversitesi, Sosyal Bilimler Enstitüsü*, Ankara.
- Fennema, E., Carpenter, T. P., Franke, M. L., Levi, L., Jacobs, V. B. and Empson, S. B. (1996). A Longitudinal Study of Learning to Use Children's Thinking in Mathematics Instruction. *Journal for Research in Mathematics Education*, 27(4), 403–434.
- Fernandez, M. L. (2005). Exploring "Lesson Study" in Teacher Preparation. (Eds: Chick, H. L. and Vincent, J. L.). *Proceedings of the 29th Conference of the International Group for the Psychology of Mathematics Education, Vol. 2*, Melbourne: PME, 305–312.
- Fernandez, C., Cannon, J. and Chokshi, S. (2003). A US-Japan Lesson Study Collaboration Reveals Critical Lenses for Examining Practice. *Teaching and Teacher Education*, 19, 171–185.
- Friel, S., Rachlin, S., Doyle, D., Nygard, C., Pugalee, D. and Ellis, M. (2001). *Navigating through Algebra in Grades 6–8*. Virginia: National Council of Teachers of Mathematics Reston.
- Henderson, P.B., Baldwin, D., Dasigi, V., Dupras, M., Fritz, S. J., Ginat, D. vd. (2001). Striving for Mathematical Thinking. *The 6th Annual Conference on Innovation and Technology in Computer Science Education, Working Group Report, ACM SIGCSE Bulletin*, 33 (4), 114–124. (30 Mart 2010), blue.butler.edu/~phenders/striving.doc
- Henderson, P. B., Fritz, S. J., Hamer, J., Hitcher, L., Marion, B., Riedesel, C. and Scharf, C. (2002). Materials Development in Support of Mathematical Thinking. *The 7th Annual Conference on Innovation and Technology in Computer Science Education, Working Group Report, ACM SIGCSE Bulletin*, 35 (2), 185–190. (30 Mart 2010), <http://www.cs.geneseo.edu/~baldwin/math-thinking/iticse2002-paper.pdf>
- Hughes, E. K. (2006). Lesson Planning as a Vehicle for Developing Pre-Service Secondary Teachers' Capacity to Focus on Students' Mathematical Thinking. Unpublished Ph.D. Thesis, *University of Pittsburgh, School of Education, Department of Instruction and Learning*, Pittsburgh.
- Hughes, E. K. and Smith, M. S. (2004). Thinking through a Lesson: Lesson Planning as Evidence of and a Vehicle for Teacher Learning. *American Educational Research Association-AERA 2004 Annual Meeting*, San Diego, CA.
- Johnson, B. and Christensen, L. (2004). *Educational Research: Quantitative, Qualitative and Mixed Approaches (Second Edition)*. Boston: Pearson Education, Inc.
- Johnson, R. B., and Onwuegbuzie, A. J. (2004). Mixed Methods Research: A Research Paradigm Whose Time has Come. *Educational Researcher*, 33(7), 14–26.
- Kazemi, E. and Franke, M. L. (2004). Teacher Learning in Mathematics: Using Student Work to Promote Collective Inquiry. *Journal of Mathematics Teacher Education*, 7, 203–235.
- Lee, K. (2006). Teacher's Knowledge of Middle School Students' Mathematical Thinking in Algebra Word Problem Solving. Unpublished Ph.D. Thesis, *Oregon State University*, Corvallis.
- Little, J., Gearhart, M., Curry, M. and Kafka, J. (2003). Looking at Student Work for Teacher Learning, Teacher Community and School Reform. *Phi Delta Kappan*, 85(3), 185–192.
- Lutfiyya, A.L. (1998). Mathematical Thinking of High School Students in Nebraska. *International Journal of Mathematical Education in Science and Technology*. 29 (1), 55–64.
- Masingila, J. and Doerr, H. M. (2002). Understanding Pre-Service Teachers' Emerging Practices through Their

- Analyses of a Multimedia Case Study Of Practice. *Journal of Mathematics Teacher Education*, 5, 235–263.
- Milli Eğitim Bakanlığı [MEB] (2005). *Ortaöğretim Matematik (9,10,11 ve 12. Sınıflar) Dersi Öğretim Programı*. Milli Eğitim Bakanlığı, Ankara.
- Milli Eğitim Bakanlığı [MEB] (2013). *Ortaöğretim Matematik Dersi (9,10,11 ve 12. Sınıflar) Öğretim Programı*. Milli Eğitim Bakanlığı, Ankara.
- Metz, M. L. D. (2007). A Study of High School Mathematics Teachers' Ability to Identify and Create Questions that Support Students' Understanding of Mathematics. Unpublished Ph.D. Thesis, *University of Pittsburgh, School of Education, Department of Instruction and Learning*, Pittsburgh.
- Miles, M. B. and Huberman, A. M. (1994). *Qualitative Data Analysis. Second Edition*. London: SAGE.
- Mubark, M. (2005). Mathematical Thinking and Mathematical Achievement of Students in the Year of 11 Scientific Stream in Jordan. Unpublished Ph.D. Thesis, *University of Newcastle, School of Education and Arts*, Callaghan.
- Ovayolu, Ö.(2010). Türkiye'deki Öğrencilerin PISA 2006 Matematik Alt Testindeki Düşünme Süreçlerine İlişkin Puan Dağılımları. Yayınlanmamış Yüksek Lisans Tezi, *Ankara Üniversitesi Eğitim Bilimleri Enstitüsü*, Ankara.
- Öğretmen Yetiştirme ve Geliştirme Genel Müdürlüğü [ÖYEGM] (2008). *Matematik Öğretmeni Özel Alan Yeterlikleri*. Milli Eğitim Bakanlığı Öğretmen Yetiştirme ve Eğitimi Genel Müdürlüğü, Ankara. (30 Mart 2010), <http://otmg.meb.gov.tr/alanmatematik.html#>
- Öğretmen Yetiştirme ve Geliştirme Genel Müdürlüğü [ÖYEGM] (2009). *Özel Alan Yeterlikleri Matematik Komisyonu 2.Dönem Raporu*. Milli Eğitim Bakanlığı Öğretmen Yetiştirme ve Eğitimi Genel Müdürlüğü, Ankara. (30 Mart 2010), <http://otmg.meb.gov.tr/belgeler/raporlar/matematik%20rapor%202.pdf>
- Schifter, D. (1998). Learning Mathematics for Teaching: From a Teachers' Seminar to the Classroom. *Journal of Mathematics Teacher Education*, 1(1), 55–87.
- Sherin, M. and Han, S. Y. (2004). Teacher Learning in the Context of a Video Club. *Teaching and Teacher Education*, 20, 163–183.
- Smith, M.S., Bill, V. and Hughes, E.K. (2008). Thinking through a Lesson Protocol: A Key for Successfully Implementing High-Level Tasks. *Mathematics Teaching in the Middle School*, 14(3), 132–138.
- Stacey, K. (2006). What is Mathematical Thinking and Why is it Important? *APEC-Tsukuba International Conference*, Tokyo and Sapporo, Japan. (30 Mart 2010), http://www.apecneted.org/resources/files/12_3-4_06_1_Stacey.pdf
- Stein, M. K., Engle, R. A., Hughes, E. K. and Smith, M. S. (2008). Orchestrating Productive Mathematical Discussions: Five Practices for Helping Teachers Move Beyond Show and Tell. *Mathematical Thinking and Learning*, 10, 313–340.
- Umay, A. (1992). Matematiksel Düşünmede Süreci ve Sonucu Yoklayan Testler Arasında Bir Karşılaştırma. Yayınlanmamış Doktora Tezi, *Hacettepe Üniversitesi Sosyal Bilimler Enstitüsü*, Ankara.
- Vacc, N. N. and Bright, G. W. (1999). Elementary Preservice Teachers' Changing Beliefs and Instructional Use of Children's Mathematical Thinking. *Journal for Research in Mathematics Education*, 30(1), 89–110.
- Warfield, J. (2001). Where Mathematics Content Knowledge Matters: Learning about and Building on Children's Mathematical Thinking. (Eds: Wood, T., Nelson, B. S. and Warfield, J.), *Beyond Classical Pedagogy: Teaching Elementary School Mathematics*, Mahwah, NJ: Lawrence Erlbaum Associates, 135–155.
- Weiss, I. R., Pasley, J. D., Smith, P. S., Banilower, E. R. and Heck, D. J. (2003). *Looking inside the Classroom: A Study of K–12 Mathematics and Science Education in the United States*. Chapel Hill, NC: Horizon Research. (30 Mart 2010), <http://www.horizon-research.com/insidetheclassroom/reports/highlights/highlights.pdf>
- Yeşildere, S. (2006). Farklı Matematiksel Güce Sahip İlköğretim 6, 7 ve 8. Sınıf Öğrencilerinin Matematiksel Düşünme ve Bilgiyi Oluşturma Süreçlerinin İncelenmesi. Yayınlanmamış Doktora Tezi, *Dokuz Eylül Üniversitesi Eğitim Bilimleri Enstitüsü*, İzmir.
- Yıldırım, C. (2008). *Matematiksel Düşünme*. İstanbul: Remzi Kitapevi.
- Yıldırım, A. ve Simsek, H. (2006). *Sosyal Bilimlerde Nitel Araştırma Yöntemleri*. Ankara: Seçkin Yayıncılık.

EK A. Öğretmen Adaylarının Planlama Becerilerini Belirlemek İçin Kullanılan “Grafiklerden

Açıklamalara” Problemi¹

Öğrencilerinizle grafik okuma ve yorumlama konusunda çalıştığınızı düşününüz. İşleyeceğiniz derste kullanmak için Grafiklerden Açıklamalara Problemlerini seçtiniz.

Grafiklerden Açıklamalara Problemlerini temel alan bir ders planlayınız.

Lütfen planınızı mümkün olduğunca ayrıntılarıyla tanımlayınız.

Grafiklerden Açıklamalara

İsim: _____

1. Ali ve babası, bir 100 metre yarışına katılmıştır. Ali, babası koşmaya başladıktan 3 saniye sonra, yarışa başladı. Grafik, Ali'nin ve babasının zaman içinde ne kadar mesafe koştuğu hakkında bilgi vermektedir. Yarışı kimin kazandığı ile ilgili bir açıklama yazınız; yarışın nasıl kazanıldığını tanımlayınız. Her birinin nasıl koştuğunu tanımlayan iki doğru paralel olsaydı, yarışı kimin kazandığı konusunda grafik size ne anlatırdı?

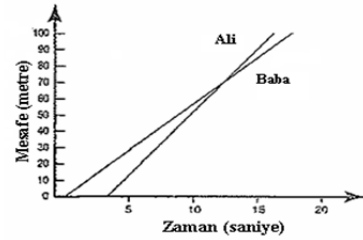

2. Grafik, bir limonata standında satılan limonata miktarı ve kar arasındaki ilişkiyi göstermektedir. Limonata standı karının, nasıl belirlendiği konusunda bir açıklama yazınız. Doğru sıfırın altında olduğunda ve doğru yatay eksenini kestiğinde ne gösterildiğini ifade ediniz (Bu grafik, satıcıya ücret ödenmediğini ve stand için kira ücreti verilmediğini farz etmektedir).

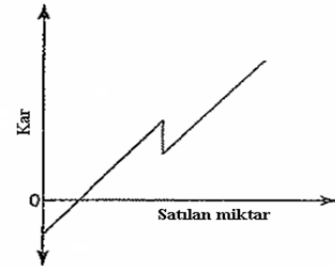

3. Grafik, bir göndere çekilen bir bayrağı göstermektedir. Bayrağın hareketini tanımlayan bir açıklama yazınız, gönderin yüksekliğinin (bayrağın çıktığı en yüksek nokta) hesaplaması için ne düşünüyorsunuz? Grafiğin şeklini açıklayınız.

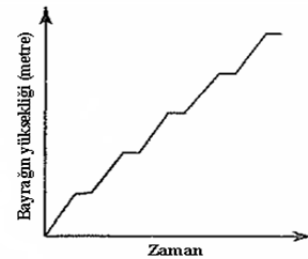

4. Grafikler, bir yarış açıklamasını betimlemek için kullanılabilir. Burada grafik iki ortaokul öğrencisi (Ayşe ve Fatma) arasında gerçekleşen bir yüzme yarışını göstermektedir. Bu yarışta ne olduğunu tanımlayan bir açıklama yazınız.

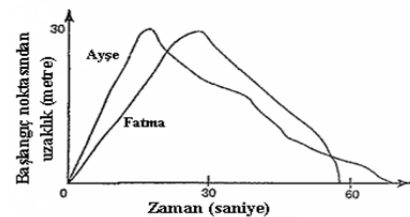

¹ Grafiklerden Açıklamalara problemi Navigating through Algebra in Grades 6–8 (Friel vd., 2001) adlı ders kitabından Türkçeye uyarlanmıştır.

BAYES RISK FOR SELECTION THE MEDIAN CATEGORY FROM EVEN SAMPLE SIZE IN K-NOMIAL DISTRIBUTION

Kawther Fawzi HAMZA

University of Babylon, Iraq

Department of Mathematic, 2014

k.sultani@yahoo.com

ABSTRACT: Bayes risk procedure is proposed for selecting the median (middle most value) in multinomial cell when the number of observation is even .Bayesian decision –theoretic approach with linear loss function and conjunction prior Dirichlet distribution is used to construct this procedure for it we need to deriving $E_{\pi(p|n)} [p_{[e]}]$. Some concluding remarks and suggestions for future work are also included.

1. INTRODUCTION

During the early fifties, it was pointed out by several researchers that testing the homogeneity of population means or variances is not satisfactory solution to a comparison of performance of several populations. One may wish to either rank them according to their performance or select one or more from among them for future use or future evaluation. These problems are known as ranking and selection problem.[4]

Consider a k-nomial distribution which is characterized by k events (cells) with probability vector

$\underline{p} = (p_1, \dots, p_h, p_{h+1}, \dots, p_k)$, where p_i is the probability of the event E_i ($1 \leq i \leq k$) with $\sum_{i=1}^k p_i = 1$.

When m is even observation, the median dependent on n_h, n_{h+1} and p_h, p_{h+1} , where $h=k/2$. Let

$n_1, \dots, n_h, n_{h+1}, \dots, n_k$ be respective frequencies in k cells of the distribution with $\sum_{i=1}^k n_i = m$. Further, let

$p_{[1]} \leq \dots \leq p_{[h]}, p_{[h+1]} \leq \dots \leq p_{[k]}$ denote the ordered values of the p_i ($1 \leq i \leq k$). It is assumed that the values of p_i and of the $p_{[j]}$ ($1 \leq i, j \leq k$) is completely unknown. The goal of the experimenter is to select the median probable event, that is the event associated with $E_{\pi(p|n)} [p_{[e]}]$ is also called the median cell .

According to this formulation we have a multinomial-decision selection problem.

Considerable efforts have been expended to the development of multinomial selection procedures using different approaches. The most popular one is the indifference zone approach (IZ)[5]. According to this approach, the selection procedure should guarantee the following probability requirements:

$$P\{CS\} \geq p^* \text{ whenever } p_{[k]} \geq \delta^* p_{[k-1]} \quad \dots\dots(1)$$

Where $\{\delta^*, p^*\}$ with $1 < \delta^* < \infty$, $\frac{1}{k} < p^* < 1$ are specified by the experimenter prior to the start of experimentation. $P\{CS\}$ denotes the probability of a correct selection for a given certain selection rule. Using the indifference zone approach described above, the following selection procedures have been suggested in the literature. Bechhofer, et al. (1959) proposed a single-stage procedure for selecting the multinomial event associated with subset selection procedures, where the aim is to select a nonempty subset of cells which contains the best cell with a probability at least equal to a pre-assigned number p^* , are proposed by Gupta and Nagel (1967). Goldsman (1984) first suggested the more general use of this type of procedure to find the simulated system mostly likely to produce the "most desirable" observation on a given trial, when "most desirable" can be almost any criterion of goodness[3].

The methods described so far do not take into account any prior information before the experimentation; therefore it is worth considering Bayesian approach to the selection problem[6]. Jones and Madhi (1988) proposed some suboptimal sequential schemes for selecting the most probable event using stopping rules based on the difference between the largest and next-to-the largest posterior probabilities[7][8]. In this research we constriction approach to selection the median (middle-most value) cell from multinomial distribution where an even observation and used Bayesian procedure with prior Dirichlet distribution.

2 – REVIEW OF THE MEDIAN

2-1 History[9]

The idea of the median originated in [Edward Wright](#)'s book on navigation in 1599 in a section concerning the determination of location with a [compass](#). In 1757, [Roger Boscovich](#) developed a regression method based on the L1 [norm](#) and therefore implicitly on the median. The distribution of both the sample mean and the sample median were determined by Laplace in the early 1800s. [Antoine Cournot](#) in 1843 was the first to use the term median for the value that divides a probability distribution into two equal halves. [Gustav Theodor Fechner](#) used the median in sociological and psychological phenomena. [Gustav Fechner](#) popularized the median into the formal analysis of data, although it had been used previously by Laplace. [Francis Galton](#) used the English term median in 1881, having earlier used the terms middle-most value in 1869 and the medium in 1880.

2-2 Measure of Location[1]

The median is one of a number of ways of summarizing the typical values associated with members of a statistical population; thus, it is a possible location parameter.

In statistics and probability theory, the median is the numerical value separating the higher half of a data sample, a population, or probability distribution, from the lower half. The median of a finite list of numbers can be found by arranging all the observations from lowest value to highest value and picking the middle one. If there is an even number of observations, then there is no single middle value ; the median is then usually defined to be the mean of the two middle values, which corresponds to interpreting the median as the fully trimmed mid-range. The median is of central importance in robust statistics, as it is the most resistant statistic, having a breakdown point 50% : so long as no more than half the data is contaminated , the median will not give an arbitrarily large result. A median is only defined on ordered one-dimensional data, and is independent of any number of dimensions.

2-3 Some Related Concepts with Median and Applications[8]

The median is used primarily for [skewed](#) distributions, which it summarizes differently than the [arithmetic mean](#) , and it might be seen as a better indication of [central tendency](#) (less susceptible to the exceptionally large value in data) than the [arithmetic mean](#) .Calculation of medians is a popular technique in [summary statistics](#) and [summarizing statistical data](#), since it is simple to understand and easy to calculate, while also giving a measure that is more robust in the presence of [outlier](#) values than is the [mean](#).

Pseudo-median:-For univariate distributions that are symmetric about one median, the [Hodges–Lehmann estimator](#) is a robust and highly efficient estimator of the population median; for non-symmetric distributions, the Hodges–Lehmann estimator is a robust and highly efficient estimator of the population pseudo-median, which is the median of a symmetrized distribution and which is close to the population median

Median filter:- In [signal processing](#), it is often desirable to be able to perform some kind of [noise reduction](#) on an image or signal. The median filter is a nonlinear [digital filtering](#) technique, often used to remove [noise](#).

Cluster analysis :-In [cluster analysis](#), the [k-medians clustering](#) algorithm provides a way of defining clusters, in which the criterion of maximizing the distance between cluster-means that is used in [k-means clustering](#), is replaced by maximizing the distance between cluster-medians.

Median-Median Line:-This is a method of robust regression. The idea dates back to [Wald](#) in 1940 who suggested dividing a set of bivariate data into two halves depending on the value of the independent parameter \mathcal{X} : a left half with values less than the median and a right half with values greater than the median.

Median graph:- In [mathematics](#), and more specifically [graph](#) median graph is an [undirected graph](#) in which ever y three

[theory](#), a [vertices](#) a,



The median of three vertices in a

b , and c have a unique median: a vertex $m(a,b,c)$ that belongs to [shortest paths](#) between each pair of a , b , and c .

Some applications are as follows.

- the highest flood waters (useful when planning for future emergencies).
- In [non-parametric statistics](#), the Theil–Sen estimator, also known as Sen's slope estimator, slope selection, the single median method is a method for [robust linear regression](#) that chooses the [median slope](#) among all lines through pairs of two-dimensional sample points.
- the lowest winter temperature recorded in the last 50 years.
- the median price of houses sold in last month.
- A medical research team conducts a clinical study comparing the success rates of five different drug regimens for a particular disease.
- A median of a triangle is a line segment that joins the vertex of a triangle to the midpoint of the opposite side.
- The geometric median of a discrete set of sample points in a Euclidean space is the point minimizing the sum of distances to the sample points.
- In object prototype learning and similar tasks, median computation is an important technique for capturing the essential information of a given set of patterns. We extend the median concept to the domain of graphs.

2.4 Medians of Probability Distributions

For any probability distribution on the real line \mathbf{R} with cumulative distribution function F , regardless of whether it is any kind of continuous probability distribution, in particular an absolutely continuous distribution (which has a probability density function), or a discrete probability distribution, a median is by definition any real number m that satisfies the inequalities

$$P(X \leq m) \geq \frac{1}{2} \text{ and } P(X \geq m) \geq \frac{1}{2}$$

Or, equivalently, the inequalities

$$\int_{(-\infty, m]} dF(x) \geq \frac{1}{2} \text{ and } \int_{[m, \infty)} dF(x) \geq \frac{1}{2}$$

in which a Lebesgue–Stieltjes integral is used. For an absolutely continuous probability distribution with probability density function f , the median satisfies

$$P(X \leq m) = P(X \geq m) = \int_{-\infty}^m f(x) dx = \frac{1}{2}.$$

Any probability distribution on \mathbf{R} has at least one median, but there may be more than one median. Where exactly one median exists, statisticians speak of "the median" correctly; even when the median is not unique, some statisticians speak of "the median" informally.

3. Bayesian Procedure for Selecting the Median Multinomial Category (Cell)

3.1 Bayesian Decision- Theoretic Formulation

Before we introduce the Bayesian procedures, we introduce some standards definitions and notations which are needed to construct the procedures. Let $\Omega_k : \{\underline{p} = (p_1, \dots, p_h, p_{h+1}, \dots, p_k) : \sum_{i=1}^k p_i = 1 ; p_i \geq 0\}$

be the parameter space and $D = \{d_1, \dots, d_h, d_{h+1}, \dots, d_k\}$ be the decision space where in the following terminal k -decision rule:

$d_i : p_i$ is the median cell probability ($i = 1, \dots, h, h+1, \dots, k$). That is, d_i denote the decision to select the event associated with the i^{th} cell as the median probable event, after the sampling is terminated.

Let $p_{[1]} \leq \dots \leq p_{[h]} \leq p_{[h+1]} \leq \dots \leq p_{[k]}$ denote the ordered values of the p_i ($1 \leq i \leq k$) the goal of the experimenter is to select the median cell probability, that is the cell associated with $p_{[e]}$.

Suppose the loss function in making decisions d_i , defined on $\Omega_k \times D$, is given as follows.

$$L(d_i, \underline{p}^*) = \begin{cases} k^*(p_{[e]} - p_i) & \text{if } (p_{[e]} \neq p_i) \\ 0 & \text{if } (p_{[e]} = p_i) \end{cases} \quad \dots\dots (2)$$

That is the loss if decision d_i is made when the true value of $\underline{p} = \underline{p}^*$. Where $p_{[e]}$ is the middle most value or equal to $\frac{p_{[h]} + p_{[h+1]}}{2}$ and k^* is the loss constant, giving losses in terms of cost.

The Bayesian approach requires that we specify a prior probability density function $\pi(\underline{p})$, expressing our beliefs about \underline{p} before we obtain the data. From a mathematical point of view, it would be convenient if \underline{p} is assigned a prior distribution which is a member of a family of distributions closed under multinomial sampling or as a member of the conjugate family. The conjugate family in this case is the family of Dirichlet distribution. Accordingly, let \underline{p} is assigned Dirichlet prior distribution with parameters $m', n'_1, n'_h, n'_{h+1}, \dots, n'_k$. The normalized density function is given by

$$\pi(\underline{p}) = \frac{\Gamma\left(\sum_{i=1}^k n'_i\right)}{\prod_{i=1}^k \Gamma(n'_i)} \prod_{i=1}^k p_i^{n'_i-1}, \text{ where } m' = \sum_{i=1}^k n'_i \quad \dots\dots (3)$$

And the marginal distribution for p_i is Beta density

$$f(p_i) = \frac{(m' - 1)!}{(n'_i - 1)!(m' - n'_i - 1)!} p_i^{n'_i-1} (1 - p_i)^{m'-n'_i-1}$$

Here $\underline{n}' = (n'_1, \dots, n'_h, n'_{h+1}, \dots, n'_k)$, are regarded as hyperparameters specifying the prior distribution. They can be thought of "imaginary counts" from prior experience. If N_i be the number of times that category i is chosen in m independent trials, then

$\underline{N} = (N_1, \dots, N_k)$ has a multinomial distribution with probability mass function

$$P_r(N_1 = n_1, \dots, N_h = n_h, N_{h+1} = n_{h+1}, \dots, N_k = n_k \mid p_1, \dots, p_k) = P(\underline{n} \mid \underline{p}) \\ = \frac{m!}{n_1! \dots n_h! n_{h+1}! \dots n_k!} \prod_{i=1}^k p_i^{n_i}, \text{ where } \sum_{i=1}^k n_i = m, \underline{n} = (n_1, \dots, n_h, n_{h+1}, \dots, n_k).$$

Since

$$P(\underline{n} \mid \underline{p}) \propto p_1^{n_1} \dots p_1^{n_h} p_1^{n_{h+1}} \dots p_k^{n_k} \text{ and } \pi(\underline{p}) \propto p_1^{n'_1-1} \dots p_h^{n'_h-1} p_{h+1}^{n'_{h+1}-1} \dots p_k^{n'_k-1},$$

then the posterior is $\pi(\underline{p} \mid \underline{n}) \propto p_1^{n_1+n'_1-1} \dots p_1^{n_h+n'_h-1} p_1^{n_{h+1}+n'_{h+1}-1} \dots p_k^{n_k+n'_k-1}$

This is a member of the Dirichlet family with parameters

$$n_i'' = n_i' + n_i \text{ and } m'' = m' + m \quad (i=1, \dots, k).$$

Hence, the posterior distribution has density function

$$\pi(\underline{p} | \underline{n}) = \frac{(m'' - 1)!}{(n_1'' - 1)! \dots (n_h'' - 1)! (n_{h+1}'' - 1)! \dots (n_k'' - 1)!} p_1^{n_1''-1} \dots p_h^{n_h''-1} p_{h+1}^{n_{h+1}''-1} \dots p_k^{n_k''-1}$$

with posterior mean $\hat{p}_i = \frac{n_i''}{m''}$ ($i= 1, 2, \dots, k$), n_i'' will be termed the posterior frequency in the i^{th} cell. The marginal posterior distribution for p_i is the beta distribution with probability density function

$$f(p_i | n_i'') = \frac{\Gamma(m'')}{\Gamma(n_i'')\Gamma(m'' - n_i'')} p_i^{n_i''-1} (1 - p_i)^{m''-n_i''-1}.$$

Where Γ is gamma function.

3.2 The Stopping Risks

In this section, we derive the stopping risks (Bayes risk) of making decision d_i for linear loss function. The stopping risk (the posterior expected loss) of the terminal decision d_i when the posterior distribution for \underline{p} has parameters $(n_1'', \dots, n_h'', n_{h+1}'', \dots, n_k''; m'')$, that is when the sample path has reached $(n_1'', \dots, n_h'', n_{h+1}'', \dots, n_k''; m'')$ from the origin $(n_1', \dots, n_h', n_{h+1}', \dots, n_k'; m')$, denoted by $S_h(n_1'', \dots, n_h'', n_{h+1}'', \dots, n_k''; m'')$ can be found as follows.

$$\begin{aligned} S_i(n_1'', \dots, n_h'', n_{h+1}'', \dots, n_k''; m'') &= \frac{E}{\pi(\underline{p}|\underline{n})} [L(d_i, \underline{p}^*)] \\ &= k^* \left[\frac{E}{\pi(\underline{p}|\underline{n})} (\mathbf{p}_{[e]}) - \frac{n_i''}{m''} \right] \end{aligned} \quad \dots (4)$$

Since the number of observation is even, the value of $\frac{E}{\pi(\underline{p}|\underline{n})} [\mathbf{p}_{[e]}]$ is equal to $\frac{E}{\pi(\underline{p}|\underline{n})} [f(\mathbf{p}_{[h]}, \mathbf{p}_{[h+1]})]$ and is derived as follows.

$$\frac{E}{\pi(\underline{p}|\underline{n})} [f(\mathbf{p}_{[h]}, \mathbf{p}_{[h+1]})] = \int_0^1 \int_0^1 f(\mathbf{p}_{[h]}, \mathbf{p}_{[h+1]}) g(\mathbf{p}_{[h]}, \mathbf{p}_{[h+1]}) dp_{[h]} dp_{[h+1]},$$

Where $g(\mathbf{p}_{[h]}, \mathbf{p}_{[h+1]})$ be the joint probability density function of the median order statistics $\mathbf{p}_{[h]}, \mathbf{p}_{[h+1]}$.

$$g(\mathbf{p}_{[h]}, \mathbf{p}_{[h+1]}) = \frac{k!}{(h-1)!(k-h-1)!} [F(p_{[h]})]^{h-1} [1 - F(p_{[h+1]})]^{k-h-1} f(p_{[h]})f(p_{[h+1]})$$

and

$$\begin{aligned} f(\mathbf{p}_{[h]}, \mathbf{p}_{[h+1]}) &= \frac{p_{[h]} + p_{[h+1]}}{2}. \text{ Let the ordered values of } n_1'', \dots, n_h'', n_{h+1}'', \dots, n_k'' \text{ is} \\ n_{[1]}'' \leq \dots \leq n_{[h]}'' \leq n_{[h+1]}'' \leq \dots \leq n_{[k]}''. \text{ The marginal posterior probability density function of } p_{[h]} \text{ \&} \\ p_{[h+1]} \text{ are respectively} \end{aligned}$$

$$f(p_{[h]}) = \frac{(m'' - 1)!}{(n_{[h]}'' - 1)!(m'' - n_{[h]}'' - 1)!} p_{[h]}^{n_{[h]}''-1} (1 - p_{[h]})^{m''-n_{[h]}''-1},$$

$$f(p_{[h+1]}) = \frac{(m'' - 1)!}{(n''_{[h+1]} - 1)!(m'' - n''_{[h+1]} - 1)!} p_{[h+1]}^{n''_{[h+1]} - 1} (1 - p_{[h+1]})^{m'' - n''_{[h+1]} - 1}.$$

and the cumulative density function of $p_{[h]}$ & $p_{[h+1]}$ are respectively

$$F(p_{[h]}) = \sum_{j=n''_{[h]}}^{m''-1} \frac{(m'' - 1)!}{j!(m'' - 1 - j)!} \cdot p_{[h]}^j (1 - p_{[h]})^{m''-1-j}$$

$$F(p_{[h+1]}) = \sum_{L=n''_{[h+1]}}^{m''-1} \frac{(m'' - 1)!}{L!(m'' - 1 - L)!} \cdot p_{[h+1]}^L (1 - p_{[h+1]})^{m''-1-L}$$

Then,

$$g(p_{[h]}, p_{[h+1]}) = \frac{k!}{(h-1)!(k-h-1)!} \left[\sum_{j=n''_{[h]}}^{m''-1} \frac{(m'' - 1)!}{j!(m'' - 1 - j)!} \cdot p_{[h]}^j (1 - p_{[h]})^{m''-1-j} \right]^{h-1} \left[1 - \left\langle \sum_{l=n''_{[h+1]}}^{m''-1} \frac{(m'' - 1)!}{l!(m'' - 1 - l)!} p_{[h+1]}^l (1 - p_{[h+1]})^{m''-1-l} \right\rangle \right]^{k-h-1} \left\langle \frac{(m'' - 1)!}{(n''_{[h+1]} - 1)!(m'' - n''_{[h+1]} - 1)!} p_{[h+1]}^{n''_{[h+1]} - 1} (1 - p_{[h+1]})^{m'' - n''_{[h+1]} - 1} \right\rangle \dots \dots \dots (5)$$

$$E_{\pi(p_{[h]}, p_{[h+1]})} [f(p_{[h]}, p_{[h+1]})] = \int_0^1 \int_0^1 \left\{ \left(\frac{p_{[h]} + p_{[h+1]}}{2} \right) \left(\frac{k!}{(h-1)!(k-h-1)!} \right) \left[\sum_{j=n''_{[h]}}^{m''-1} \frac{(m'' - 1)!}{j!(m'' - 1 - j)!} \cdot p_{[h]}^j (1 - p_{[h]})^{m''-1-j} \right]^{h-1} \left[1 - \left\langle \sum_{l=n''_{[h+1]}}^{m''-1} \frac{(m'' - 1)!}{l!(m'' - 1 - l)!} \cdot p_{[h+1]}^l (1 - p_{[h+1]})^{m''-1-l} \right\rangle \right]^{k-h-1} \left\langle \frac{(m'' - 1)!}{(n''_{[h+1]} - 1)!(m'' - n''_{[h+1]} - 1)!} p_{[h+1]}^{n''_{[h+1]} - 1} (1 - p_{[h+1]})^{m'' - n''_{[h+1]} - 1} \right\rangle \right\}$$

Hence,

$$\left\langle \frac{(m'' - 1)!}{(n''_{[h+1]} - 1)!(m'' - n''_{[h+1]} - 1)!} p_{[h+1]}^{n''_{[h+1]} - 1} (1 - p_{[h+1]})^{m'' - n''_{[h+1]} - 1} \right\rangle \left\{ dp_{[h]} dp_{[h+1]} \right. \\ = \int_0^1 \int_0^1 \left\{ \left(\frac{k!}{2(h-1)!(k-h-1)!} \right) (p_{[h]} + p_{[h+1]}) \left\langle \frac{(m'' - 1)!}{(n''_{[h]} - 1)!(m'' - n''_{[h]} - 1)!} p_{[h]}^{n''_{[h]} - 1} (1 - p_{[h]})^{m'' - n''_{[h]} - 1} \right\rangle \right. \\ \left. \left\langle \frac{(m'' - 1)!}{(n''_{[h+1]} - 1)!(m'' - n''_{[h+1]} - 1)!} p_{[h+1]}^{n''_{[h+1]} - 1} (1 - p_{[h+1]})^{m'' - n''_{[h+1]} - 1} \right\rangle \left[\sum_{j=n''_{[h]}}^{m''-1} \frac{(m'' - 1)!}{j!(m'' - 1 - j)!} \cdot p_{[h]}^j (1 - p_{[h]})^{m''-1-j} \right]^{h-1} \right. \\ \left. \left[1 - \left\langle \sum_{l=n''_{[h+1]}}^{m''-1} \frac{(m'' - 1)!}{l!(m'' - 1 - l)!} \cdot p_{[h+1]}^l (1 - p_{[h+1]})^{m''-1-l} \right\rangle \right]^{k-h-1} \right\} dp_{[h]} dp_{[h+1]}$$

$$\begin{aligned}
&= \int_0^1 \int_0^1 \left(\frac{(m''-1)!}{(n''_{[h]}-1)!(m''-n''_{[h]}-1)!} \right) \left(\frac{(m''-1)!}{(n''_{[h+1]}-1)!(m''-n''_{[h+1]}-1)!} \right) \left(\frac{k!}{2(h-1)!(k-h-1)!} \right) \\
&\left\{ \left[\sum_{j=n''_{[h]}}^{m''-1} \frac{(m''-1)!}{j!(m''-1-j)!} \cdot P_{[h]}^j (1-P_{[h]})^{m''-1-j} \right]^{h-1} \left[1 - \left\langle \sum_{l=n''_{[h+1]}}^{m''-1} \frac{(m''-1)!}{l!(m''-1-l)!} \cdot P_{[h+1]}^l (1-P_{[h+1]})^{m''-1-l} \right\rangle \right]^{k-h-1} \right\} \\
&\left(P_{[h]} + P_{[h+1]} \right) \left\langle P_{[h]}^{n''_{[h]}-1} (1-P_{[h]})^{m''-n''_{[h]}-1} \right\rangle \left\langle P_{[h+1]}^{n''_{[h+1]}-1} (1-P_{[h+1]})^{m''-n''_{[h+1]}-1} \right\rangle dp_{[h]} dp_{[h+1]} \\
&= \left(\frac{(m''-1)!}{(n''_{[h]}-1)!(m''-n''_{[h]}-1)!} \right) \left(\frac{(m''-1)!}{(n''_{[h+1]}-1)!(m''-n''_{[h+1]}-1)!} \right) \left(\frac{k!}{2(h-1)!(k-h-1)!} \right) \\
&\left\{ \int_0^1 \int_0^1 \left[\sum_{j=n''_{[h]}}^{m''-1} \frac{(m''-1)!}{j!(m''-1-j)!} \cdot P_{[h]}^j (1-P_{[h]})^{m''-1-j} \right]^{h-1} \left[1 - \left\langle \sum_{l=n''_{[h+1]}}^{m''-1} \frac{(m''-1)!}{l!(m''-1-l)!} \cdot P_{[h+1]}^l (1-P_{[h+1]})^{m''-1-l} \right\rangle \right]^{k-h-1} \right\} \\
&\left\langle P_{[h]}^{n''_{[h]}-1} (1-P_{[h]})^{m''-n''_{[h]}-1} \right\rangle \left\langle P_{[h+1]}^{n''_{[h+1]}-1} (1-P_{[h+1]})^{m''-n''_{[h+1]}-1} \right\rangle dp_{[h]} dp_{[h+1]} + \left\{ \int_0^1 \int_0^1 \left[\sum_{j=n''_{[h]}}^{m''-1} \frac{(m''-1)!}{j!(m''-1-j)!} \cdot P_{[h]}^j (1-P_{[h]})^{m''-1-j} \right]^{h-1} \right. \\
&\left. \left[1 - \left\langle \sum_{l=n''_{[h+1]}}^{m''-1} \frac{(m''-1)!}{l!(m''-1-l)!} \cdot P_{[h+1]}^l (1-P_{[h+1]})^{m''-1-l} \right\rangle \right]^{k-h-1} \left\langle P_{[h]}^{n''_{[h]}-1} (1-P_{[h]})^{m''-n''_{[h]}-1} \right\rangle \left\langle P_{[h+1]}^{n''_{[h+1]}-1} (1-P_{[h+1]})^{m''-n''_{[h+1]}-1} \right\rangle \right\} dp_{[h]} dp_{[h+1]}
\end{aligned}$$

Then,

$$\begin{aligned}
E_{\pi(\underline{p})} [f(\mathbf{p}_{[h]}, \mathbf{p}_{[h+1]})] &= \left(\frac{(m''-1)!}{(n''_{[h]}-1)!(m''-n''_{[h]}-1)!} \right) \left(\frac{(m''-1)!}{(n''_{[h+1]}-1)!(m''-n''_{[h+1]}-1)!} \right) \left(\frac{k!}{2(h-1)!(k-h-1)!} \right) \\
&\left\{ \int_0^1 \int_0^1 \left(1 - P_{[h]} \right)^{(m''-1)(h-1)} \sum_{j_1=n''_{[k]}}^{m''-1} \sum_{j_2=n''_{[k]}}^{m''-1} \dots \sum_{j_{k-1}=n''_{[k]}}^{m''-1} \frac{\left(\frac{P_{[h]}}{1-P_{[h]}} \right)^{j_1+j_2+\dots+j_{k-1}}}{j_1!(m''-j_1-1)! \dots j_{k-1}!(m''-j_{k-1}-1)!} \left[\sum_{J=0}^{k-h-1} \binom{k-h-1}{J} \right. \right. \\
&\left. \left. (-1)^J ((m''-1)!)^J \sum_{J_1=n''_{[1]}}^{m''-1} \sum_{J_2=n''_{[1]}}^{m''-1} \dots \sum_{J_l=n''_{[1]}}^{m''-1} \left(\frac{P_{[h+1]}}{1-P_{[h+1]}} \right)^{J_1+J_2+\dots+J_l} \frac{P_{[h+1]}^{n''_{[h+1]}-1} (1-P_{[h+1]})^{m''-n''_{[h+1]}-1}}{j_1!(m''-j_1-1)! \dots j_l!(m''-j_l-1)!} \right] \right. \\
&\left. \left\langle P_{[h]}^{n''_{[h]}-1} (1-P_{[h]})^{m''-n''_{[h]}-1} \right\rangle \left\langle P_{[h+1]}^{n''_{[h+1]}-1} (1-P_{[h+1]})^{m''-n''_{[h+1]}-1} \right\rangle dp_{[h]} dp_{[h+1]} + \left\{ \int_0^1 \int_0^1 \left(1 - P_{[h]} \right)^{(m''-1)(h-1)} \sum_{j_1=n''_{[k]}}^{m''-1} \sum_{j_2=n''_{[k]}}^{m''-1} \dots \sum_{j_{k-1}=n''_{[k]}}^{m''-1} \right. \\
&\left. \frac{\left(\frac{P_{[h]}}{1-P_{[h]}} \right)^{j_1+j_2+\dots+j_{k-1}}}{j_1!(m''-j_1-1)! \dots j_{k-1}!(m''-j_{k-1}-1)!} \left[\sum_{J=0}^{k-h-1} \binom{k-h-1}{J} (-1)^J ((m''-1)!)^J \sum_{J_1=n''_{[1]}}^{m''-1} \sum_{J_2=n''_{[1]}}^{m''-1} \dots \sum_{J_l=n''_{[1]}}^{m''-1} \left(\frac{P_{[h+1]}}{1-P_{[h+1]}} \right)^{J_1+J_2+\dots+J_l} \right. \right. \\
&\left. \left. \frac{P_{[h+1]}^{n''_{[h+1]}-1} (1-P_{[h+1]})^{m''-n''_{[h+1]}-1}}{j_1!(m''-j_1-1)! \dots j_l!(m''-j_l-1)!} \right] \left\langle P_{[h]}^{n''_{[h]}-1} (1-P_{[h]})^{m''-n''_{[h]}-1} \right\rangle \left\langle P_{[h+1]}^{n''_{[h+1]}-1} (1-P_{[h+1]})^{m''-n''_{[h+1]}-1} \right\rangle dp_{[h]} dp_{[h+1]} \right\}
\end{aligned}$$

$$\begin{aligned}
\pi_{\langle p|z \rangle} E [P_{[e]}] &= \left(\frac{(m''-1)!}{(n''_{[h]}-1)!(m''-n''_{[h]}-1)!} \right) \left(\frac{(m''-1)!}{(n''_{[h+1]}-1)!(m''-n''_{[h+1]}-1)!} \right) \left(\frac{k!}{2(h-1)!(k-h-1)!} \right) \\
&\left\{ \sum_{j_1=n''_{[k]}}^{m''-1} \sum_{j_2=n''_{[k]}}^{m''-1} \dots \sum_{j_{k-1}=n''_{[k]}}^{m''-1} 1/j_1!(m''-j_1-1)! \dots j_{h-1}(m''-j_{h-1}-1)! \langle \Gamma(n''_{[h]}+j_1+\dots+j_{h-1}) \right. \\
&\frac{\Gamma(m''h-h-m''-j_1-\dots-j_{h-1})}{\Gamma(n''_{[h]}+m''h-m''-h)} - \frac{\Gamma(m''+j_1+\dots+j_{h-1}-1)\Gamma(m''h-h-m''-j_1-\dots-j_{h-1})}{\Gamma(m''h-h)} \left. \right\} \\
&\left[\sum_{J=0}^{k-h-1} \binom{k-h-1}{J} (-1)^J ((m''-1)!)^J \sum_{J_1=n''_{[1]}}^{m''-1} \sum_{J_2=n''_{[1]}}^{m''-1} \dots \sum_{J_l=n''_{[1]}}^{m''-1} 1/j_1!(m''-j_1-1)! \dots j_l!(m''-j_l-1)! \langle \Gamma(n''_{[h+1]}+J_1+\dots \right. \\
&\dots + J_{l-1}) \frac{\Gamma(Jm''-J+1-J_1-\dots-J_{l-1})}{\Gamma(n''_{[h+1]}+Jm''-J)} - \frac{\Gamma(Jm''-J-J_1-\dots-J_{l-1}+1)\Gamma(m''-1-J_1-\dots-J_{l-1})}{\Gamma(m''+Jm''-J-1)} \left. \right\} \\
&+ \left\{ \sum_{j_1=n''_{[k]}}^{m''-1} \sum_{j_2=n''_{[k]}}^{m''-1} \dots \sum_{j_{k-1}=n''_{[k]}}^{m''-1} \frac{1}{j_1!(m''-j_1-1)! \dots j_{h-1}(m''-j_{h-1}-1)!} \langle \Gamma(n''_{[h]}+j_1+\dots+j_{h-1}) \right. \\
&\frac{\Gamma(m''h-h-m''-2-j_1-\dots-j_{h-1})}{\Gamma(n''_{[h]}+m''h-m''-h-2)} - \frac{\Gamma(m''+j_1+\dots+j_{h-1}-1)\Gamma(m''h-h-m''+2-j_1-\dots-j_{h-1})}{\Gamma(m''h-h-1)} \left. \right\} \\
&\left[\sum_{J=0}^{k-h-1} \binom{k-h-1}{J} (-1)^J ((m''-1)!)^J \sum_{J_1=n''_{[1]}}^{m''-1} \sum_{J_2=n''_{[1]}}^{m''-1} \dots \sum_{J_l=n''_{[1]}}^{m''-1} \frac{1}{J_1!(m''-J_1-1)! \dots J_l!(m''-J_l-1)!} \langle \Gamma(2n''_{[h+1]}+J_1 \right. \\
&+ \dots + J_l+1) \frac{\Gamma(m''-n''_{[h+1]}-J_1+\dots+J_l)}{\Gamma(n''_{[h+1]}+m''+1)} - \frac{\Gamma(m''+n''_{[h+1]}+J_1+\dots+J_l)\Gamma(m''-n''_{[h+1]}-J_1+\dots+J_l)}{\Gamma(2m'')} \left. \right\}
\end{aligned}$$

Hence

$$\begin{aligned}
S_i(n''_1, \dots, n''_h, n''_{h+1}, \dots, n''_k; m'') &= k^* \left\{ \left(\frac{k!(m''-1)!(m''-1)!}{(n''_{[h]}-1)!(m''-n''_{[h]}-1)!2(h-1)!(k-h-1)!(n''_{[h+1]}-1)!(m''-n''_{[h+1]}-1)!} \right) \right. \\
&\left. \left\{ \sum_{j_1=n''_{[k]}}^{m''-1} \sum_{j_2=n''_{[k]}}^{m''-1} \dots \sum_{j_{k-1}=n''_{[k]}}^{m''-1} 1/j_1!(m''-j_1-1)! \dots j_{h-1}(m''-j_{h-1}-1)! \langle \Gamma(n''_{[h]}+j_1+\dots+j_{h-1}) \right. \right. \\
&\frac{\Gamma(m''h-h-m''-j_1-\dots-j_{h-1})}{\Gamma(n''_{[h]}+m''h-m''-h)} - \frac{\Gamma(m''+j_1+\dots+j_{h-1}-1)\Gamma(m''h-h-m''-j_1-\dots-j_{h-1})}{\Gamma(m''h-h)} \left. \right\} \\
&\left[\sum_{J=0}^{k-h-1} \binom{k-h-1}{J} (-1)^J ((m''-1)!)^J \sum_{J_1=n''_{[1]}}^{m''-1} \sum_{J_2=n''_{[1]}}^{m''-1} \dots \sum_{J_l=n''_{[1]}}^{m''-1} 1/j_1!(m''-j_1-1)! \dots j_l!(m''-j_l-1)! \langle \Gamma(n''_{[h+1]}+J_1+\dots \right. \\
&\dots + J_{l-1}) \frac{\Gamma(Jm''-J+1-J_1-\dots-J_{l-1})}{\Gamma(n''_{[h+1]}+Jm''-J)} - \frac{\Gamma(Jm''-J-J_1-\dots-J_{l-1}+1)\Gamma(m''-1-J_1-\dots-J_{l-1})}{\Gamma(m''+Jm''-J-1)} \left. \right\}
\end{aligned}$$

$$\begin{aligned}
& + \left\{ \sum_{j_1=n_{[k]}^{m''-1}}^{m''-1} \sum_{j_2=n_{[k]}^{m''-1}}^{m''-1} \dots \sum_{j_{k-1}=n_{[k]}^{m''-1}}^{m''-1} \frac{1}{j_1!(m''-j_1-1)! \dots j_{k-1}!(m''-j_{k-1}-1)!} \langle \Gamma(n_{[h]}^{m''} + j_1 + \dots + j_{k-1}) \right. \\
& \left. \frac{\Gamma(m''h - h - m'' - 2 - j_1 - \dots - j_{k-1})}{\Gamma(n_{[h]}^{m''} + m''h - m'' - h - 2)} - \frac{\Gamma(m'' + j_1 + \dots + j_{k-1} - 1) \Gamma(m''h - h - m'' + 2 - j_1 - \dots - j_{k-1})}{\Gamma(m''h - h - 1)} \right\} \\
& \left[\sum_{J=0}^{k-h-1} \binom{k-h-1}{J} (-1)^J ((m''-1)!)^J \sum_{J_1=n_{[1]}^{m''-1}}^{m''-1} \sum_{J_2=n_{[1]}^{m''-1}}^{m''-1} \dots \sum_{J_l=n_{[1]}^{m''-1}}^{m''-1} \frac{1}{J_1!(m''-J_1-1)! \dots J_l!(m''-J_l-1)!} \langle \Gamma(2n_{[h+1]}^{m''} + J_1 \right. \\
& \left. + \dots + J_l + 1) \frac{\Gamma(m'' - n_{[h+1]}^{m''} - J_1 + \dots + J_l)}{\Gamma(n_{[h+1]}^{m''} + m'' + 1)} - \frac{\Gamma(m'' + n_{[h+1]}^{m''} + J_1 + \dots + J_l) \Gamma(m'' - n_{[h+1]}^{m''} - J_1 + \dots + J_l)}{\Gamma(2m'')} \right] \left. \right\} - \frac{n_i^{m''}}{m''} \Bigg\} \\
& \dots\dots(7)
\end{aligned}$$

4. Conclusion and Directions for Future Work

4.1 Conclusions

The median is the one of a number of ways of summarizing the typical values associated with members of a statistical population; thus, it is a possible location parameter. Ranking and selection procedures provides excellent tools for selecting the middle most event when an even of observation of k competing alternatives. In this paper we attempt to apply Bayesian statistical decision theory which leads to a quite different approach to the selection problem as the concepts of loss of taking a certain decision when particular values of the parameters of interest are true, the cost of sampling and some prior information about the parameters of the underlying distributions are involved.

4.2 Directions for Future Work

Some directions for future work are given as follows:

- 1- Group sequential sampling can be tried where observations are taken in groups to build Bayesian sequential scheme for the selection problem.
- 2- The problem of selecting the any two order statistic $P_{[i]}, P_{[j]}$ probable cells can be attempted.
- 3- To simplify the formula (7) we can used stirling's approximation for large factorials .
- 4- An upper bound for risks may be found using functional analysis.
- 5- General loss functions may be tried, where linear loss is considered as a special case.
- 6- In some problems the experimenter might be interested in selecting a subset of the cells including the median cell. In this problem a correct selection is the selection of any subset including the cell with i^{th} median probability. Bayesian approach can be used to solve such as a problem.
- 7- we can used other measure location eg: range , mid-range, ...etc.

REFERENCES

1. D.Dor, and U. Zwick. Selecting the Median. SIAM Jour. Comp., 28(5):1722–1758, 1999.
2. Edson L. F. Sane, lagrangean/surrogate heuristics for p-median problems, Chapter 6, 2000.
3. Horrace, W. C. Selection procedures for order statistics in Empirical Economic studies, 1-26,2002.
4. Jones, p.w. and Madhi, S.A , Bayesan sequential methods for choosing the best Multinomial cell: Some simulation results. Statistical paper 29, 125-132, 1988.
5. Kim, S.H., and Nelson, B.L, (2003). Selecting the best system. Proceedings Winter simulation conference, Georgia Institute of Technology, North Western Universiy, 2003.

6. Mausumi, B. and Subir, K.B., Selecting the t Best cells of a Multinomial distribution. The Indian Journal of statistics, volume 61, series A, pt 1, pp. 139-147, Calcutta, 1999.
<http://202.54.54.1471/search/61a1/61a16926.pdf>
7. Ranking and selection: a comprehensive survey on the theory, Advanced Simulation.
<http://www.bilkent.edu.tr/~goren/simulation.html>
8. S. Battiato, D. C, C and G. Cincotti , An Efficient Algorithm for the Approximate Median Selection Problem. Department di Matematica, Viale A. Doria 6, I-95125 Catania, Italy, Department Of Computer Science , 01609-2280 ,October 28, 2002.
9. Median
<http://cn.wikipedia.org/wiki/median>.

THE IMPACT OF SOCIOCULTURAL DIALECTICAL METHOD ON STUDENTS' BEHAVIORAL, COGNITIVE AND EMOTIONAL ENGAGEMENT

Pinar GÖKSU

Yilmaz SAGLAM

This study aimed to determine the impact of sociocultural dialectical method (SCD) on students' behavioral, cognitive and emotional engagement. The study adopted an AB quasi-experimental model in gathering and analyzing data. The sample involved three teachers' classroom practices. The study has two main stages. In the first stage, the teachers' classroom practices were video recorded. In the second phase, the teachers were asked to use sociocultural dialectic method in their practices and those practices were also video-recorded. The practices were then analyzed according to the table, which demonstrated operational definitions for codes. The teachers' classroom practices were examined separately and each of which became a sample for analysis. The results indicated that SCD had a positive impact on students' behavioral, cognitive and emotional engagement and, compared with teachers' way of instructions, SCD caused an increase in the number of students engaged.

Keywords: Sociocultural Dialectical Method, Motivation, Behavioral Engagement, Cognitive engagement, Emotional Engagement.

EXPECTATIONS TOWARDS ADEQUACIES OF NEW IT GRADUATES BASED ON SECTOR AND EXPERIENCE OF THE EMPLOYERS

Çiğdem TURHAN
Atılım University
cigdem_t@atilim.edu.tr

İbrahim AKMAN
Atılım University
akman@atilim.edu.tr

ABSTRACT: This study analyzes the employer's expectations for new IT graduates in terms of employer's sector and experience level differences. A survey has been conducted among senior professionals and managers working in the IT sector for this purpose. For the analysis, multivariate regression technique has been used. The results indicate significant differences in the adequacies of new IT graduates working in public and private sectors in terms of adapting to new methods and techniques, software development background, software development processes, ethical responsibilities and competency in communication. The experience levels also show significant difference in terms of developing solutions to problems, software development background, using time effectively, ethical responsibilities and competency in communication.

Key words: Employer expectations, multivariate regression analysis, adequacies of graduates

INTRODUCTION

The qualifications of new IT graduates do not always conform with the expectations of employers in the computer industry. Employers look for the knowledge, competence, demeanor, and commercial awareness of new graduates to contribute to the organizations' objectives right after they start their employment (Mason et al., 2009).

Various studies have been conducted on the expected skills of the new IT graduates on different levels (Dravid et al., 2011; Fernandez-Sanz, 2009) analyzing the level of technical, personal and global skills of the engineering graduates. Yet, there have been only a few studies dealing with the Turkish IT graduates in the area of employability (Turhan & Akman, 2012).

In Turkey, only around 30,000-35,000 computer engineers have graduated so far, and from 143 IT-related departments, around 4000 graduates join them every year (Sarrafakıoğlu, 2012). According to TÜBİSAD's "Information and Communication Technology Sector Market Data Project" report for the year 2012, the Turkish IT sector is worth 78,24 billion TL with a growth of 18% from 2011, and 153,849 people are working as IT specialists in the sector (Tübisad, 2013). According to the report, by the year 2023, marking the 100th year of the republic, 400,000 more IT specialists are expected to join the force. Therefore, a large number of new IT specialists are expected in the sector every year, which implies that the qualifications they need to possess according to the IT employers become an imperative issue.

In this research, a survey has been conducted to investigate employers' expectations for new graduates in the computer industry in terms of the private and public sector differences and experience level of the employers. Different competencies of new graduates such as adapting to the new methods and technologies, software development background, communication competencies, time management skills, etc. have been analyzed in detail, and differences based on the employer's experience level and sector have been examined.

The remainder of the paper is arranged as follows. The next section introduces the research model, followed by the research design. Then, the descriptive and test results are presented which is followed by the conclusion.

RESEARCH MODEL

The literature provides studies about graduates adequacies from different perspectives. For example in their study, Rao et al. (2008) examined different approaches for estimating the cost of adequacy. In an earlier study, Steinpreis, et al., (1999) investigated the impact of gender and experience on adequacies and reported significant impact for both factors. Kapoor and Chan (2005) stated that it is important to examine the adequacy of university undergraduate programs in preparing students to become professionals with high standards. They also

pointed that an inadequate education will eventually reappear in the form of low-quality services offered by professionals. Therefore, adequacy has been included as the independent factor in this study (Figure 1).

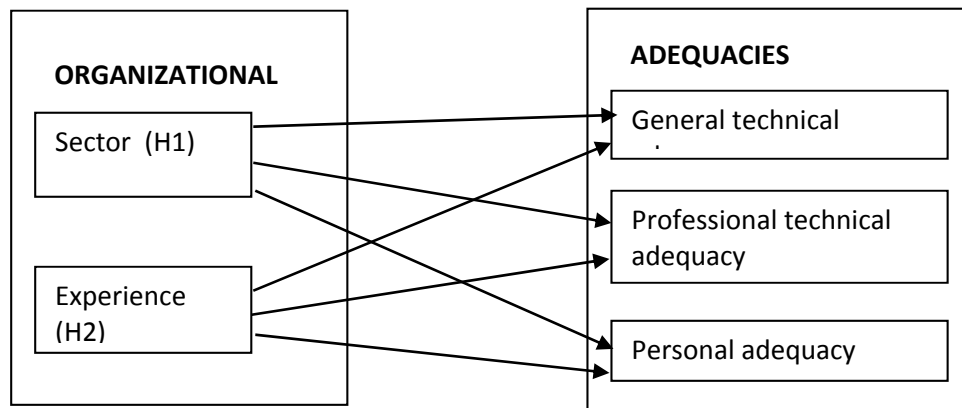

Figure 1. Research Model

The adequacies were grouped in three categories as general technical adequacies (adequacy in adapting to new methods and techniques, adequacy in developing solutions to problems); professional technical adequacies (adequacy in software development background, adequacy in software development processes); personal adequacies (adequacy in using time effectively, adequacy in ethical responsibilities, adequacy in communication). The present study performs a systematic approach to investigate the role of respondents' sector and experiences regarding their expectations in terms of mentioned adequacies of new IT graduates (Figure 1).

Various studies report the importance of organizational characteristics. For example, Jin et al. (2007) pointed that respondents' work place has significant effect in their attitude towards using IT. Additionally, Bonson and Escobar (2006), and Gupta et al. (2004) have been supporters of existence of significant diversity in IT applications between public and private sector organizations. However, the existing literature does not appear to pay attention to the impact of organizational diversity in terms of organizations' expectations from new IT graduates. Therefore, the following hypotheses of the present study were constructed to compare the differences between public -and- private sector establishments in terms of expectations from new IT graduates.

Hyp.	Definition
H1 _{1i} (i=1, 2)	Expectations on general technical adequacy i (i=1, 2) is changing depending on the sector of organization.
H1 _{2i} (i=1, 2)	Expectations on professional technical adequacy i (i=1, 2) is changing depending on the sector of organization.
H1 _{3i} (i=1, 2, 3)	Expectations on personal adequacy i (i=1, 2, 3) is changing depending on the sector of organization.

The experience has always been one of the factors included in many of the studies regarding human behavior. Experience can be measured in several ways, including work experience and computer usage (Shore et al., 2001). Stuart (1990) used experience as years of management in business and reported its significance in relation to performance. Additionally, according to Rice (2010), employees' years of experience should be recognized as a relevant factor in human resource policies. Experience, gained over time, enhances the knowledge, skills, and productivity of workers (Rice, 2010). Therefore, present study proposes experience to be included as an independent variable and the following hypotheses are postulated.

Hyp.	Definition
H2 _{1i} (i=1, 2)	Expectations on general technical adequacy i (i=1, 2) is changing depending on the experience.
H2 _{2i} (i=1, 2)	Expectations on professional technical adequacy i (i=1, 2) is changing depending on the experience.
H2 _{3i} (i=1, 2, 3)	Expectations on personal adequacy i (i=1, 2, 3) is changing depending on the experience.

RESEARCH DESIGN

A survey questionnaire was developed for testing the hypotheses. Initially, a pilot version of this questionnaire was prepared and a group of IT professionals was interviewed to finalize this questionnaire. The questionnaire

contains nine items, and each item reflects a discrete variable (Table 1). The variables “sector” and “experience” are the dependent variables, whereas the others constitute independent ones.

Table 1. Summary of Research Instrument

Quest	Variable	Definition
1	sector	Which sector do you work at? (public, private)
2	experience	What is your management (division/project) experience level? (1-5; 6-10; 11-15; 16-20; >20)
3	GT_adequacy ₁	What is the level of new graduates’ adequacies in terms of adapting to new methods and techniques in your organization?
4	GT_adequacy ₂	What is the level of new graduates’ adequacies in terms of developing solutions to problems in your organization?
5	PT_adequacy ₁	What is the level of the new graduates’ adequacies in terms of software development background in your organization?
6	PT_adequacy ₂	What is the level of new graduates’ adequacies in terms of software development processes in your organization?
7	Per_adequacy ₁	What is the level of new graduates’ adequacies in terms of using time effectively in your organization?
8	Per_adequacy ₂	What is the level of new graduates’ adequacies in terms of ethical responsibilities?
9	Per_adequacy ₃	What is the level of new graduates’ adequacies in terms of competency in communication?

The respondents were either senior IT professionals or IT/Project managers from both major government and private sector establishments. The participant organizations were selected using “judgement sampling”. A total of 72 completed survey questionnaires were received. A 5-point Likert Scale was used for questions 3-9. Multivariate regression analysis technique was utilized to represent the relationships between the dependent and independent variables.

RESULTS

The results of the present survey are presented in the following sequence. Initially, the results of the survey are presented using descriptive analysis. This is followed by the results of regression analysis for each independent adequacy factor.

Descriptive Results

Most of the respondents are from private sector establishments in this research (68%) and observed to be manager (83%) (Table 2) . The percentage of IT graduate respondents is slightly higher than graduates of other fields (59%). This is not surprising since since this was the intention during the sampling procedure and this also meets the sample requirements in this survey. Of the IT graduates, 79% are working in public sector establishments. This percentage for graduates of other branches is lower (59%). This means that most of the new IT graduates prefer working in private sector organizations since the salary standards are higher in private sector. It is interesting to note that, none of the organizations are fully happy with the qualification of new IT graduates since none of the managers in the survey reported his/her organization’s full satisfaction in terms of adequacies. This may be an indication of the fact that IT departments do not consider industry demands in their curriculum designs. However, most of the managers (65%) reported their expectations regarding adequacies were met on average by new IT graduates. This may be an evidence of the fact that the curriculums are almost the same in most of the IT departments in different universities.

Table 2. Descriptive Results

Variable	Respondents	
	Number	%
Sector	72	100
private	49	68
public	22	31
Unknown	1	1

Position	72	100
unit/project manager	60	83
senior professional	12	17
Graduation of respondent	72	100
IT	42	59
engineering	13	18
others	16	22
Unknown	1	1
Organization's satisfaction from new graduates	72	100
very much	0	0
much	11	15
average	47	65
little	8	11
very little	4	6
Unknown	2	3

Table 3. Test Results

Dependent	Independent variable	Hyp.	coeff.	p-val
Sector	GT_adequacy ₁	H1 ₁	-0.251	0.042*
	GT_adequacy ₂	H1 ₂	-0.108	0.385
	PT_adequacy ₁	H1 ₃	-0.588	0.000*
	PT_adequacy ₂	H1 ₄	0.216	0.046*
	Per_adequacy ₁	H1 ₅	-0.051	0.700
	Per_adequacy ₂	H1 ₆	0.222	0.042*
	Per_adequacy ₃	H1 ₇	-0.339	0.016*
Experience	GT_adequacy ₁	H2 ₁	0.371	0.172
	GT_adequacy ₂	H2 ₂	0.577	0.035*
	PT_adequacy ₁	H2 ₃	-0.449	0.054*
	PT_adequacy ₂	H2 ₄	0.307	0.182
	Per_adequacy ₁	H2 ₅	-0.503	0.070**
	Per_adequacy ₂	H2 ₆	0.380	0.067**
	Per_adequacy ₃	H2 ₇	0.569	0.039*

* significant at 5% significance level; ** significant at 10% significance level.

Test results

The results of regression tests for the hypotheses are given in Table 3. The inspection of p-values in Table 3 indicated that there is sufficient evidence to accept H1₁, H1₃, H1₄, H1₆ and H1₇. This means the variable “sector” has significant impact on the variables “GT_adequacy₁”, “PT_adequacy₁”, “PT_adequacy₂”, “Per_adequacy₂” and “Per_adequacy₃”. In other words, public and private sector managers have significantly different expectations from new IT graduates in terms of adequacies in adapting to new methods and techniques, software development background, software development processes, ethical responsibilities and communication. Similarly, the inspection of p-values in Table 3 indicated that there is sufficient evidence to accept H2₂, H2₃, H2₅, H2₆ and H2₇. This means the variable “experience” has significant impact on the variables “GT_adequacy₂”, “PT_adequacy₁”, “Per_adequacy₁”, “Per_adequacy₂” and “Per_adequacy₃”. This means the expectations from new IT graduates regarding adequacies in developing solutions to problems, software development background, using time effectively, ethical responsibilities and communication is significantly changing depending on managers experience.

CONCLUSION

The present study has examined the existence of diversity of managers' sector and experience in terms of selected adequacy factors of new IT graduates. Interestingly, the results revealed that, except adequacy in developing solutions to problems and adequacy in using time effectively, for all the remaining adequacy factors, the public and private sector managers have significantly different expectations. It was also found that managers' experience level does not change their expectations in terms of adequacy in adapting to new methods and adequacy of software development process of new IT graduates.

REFERENCES

- Bonson, E., & Escobar, T. (2006). Digital reporting in Eastern Europe: An empirical study, *International Journal of Accounting Information Systems*, 7, 299-318.
- Dravid, R., & Duncan, A. (2011). Engineering soft skills development to avoid hard knocks. *2011 IEEE Global Engineering Education Conference (EDUCON) – Learning Environments and Ecosystems in Engineering Education*, 354-357.
- Fernandez-Sanz, L. (2009). Personal skills for computing professionals. *Computer*, 42(10), 110-111.
- Gupta, P.B., Gould, S.J., & Pola, B. (2004). To pirate or not to pirate: a comparative study of the ethical versus other influences on the consumer's software acquisition mode decision. *Journal of Business Ethics*, 55(3), 255 – 274.
- Jin, K.G., Drozdenko, R., & Bassett, R. (2007). Information technology professionals' perceived organizational values and managerial ethics: an empirical study. *Journal of Business Ethics*, 71(2), 149-159.
- Kapoor, M. R., & Chan, K. H. (2005). Education of the professional accountant: An empirical study. *The Canadian Journal of Higher Education*, 15(2), 54-73.
- Mason, G., Williams, G., & Cranmer S. (2009). Employability skills initiatives in higher education: What effects do they have on graduate labour market outcomes? *Education Economics*, 17(1), 1-30.
- Rao, R. R., Naidu, R. S. and Jani, R. (2008). A Critical Review of the Methods Used to Estimate the Cost of An Adequate Education. *Journal of Sustainable Development*, 1(3), 98-102.
- Rice, J. K. (2010). The impact of teacher experience examining the evidence and policy implications. *National Center for Analysis of Longitudinal Data in Education Research*, Retrieved from: <http://www.urban.org/uploadedpdf/1001455-impact-teacher-experience.pdf>.
- Sarıfakioglu, B. (2012). Bilgisayar mühendislerinin örgütlenme atağı. *Elektrik Mühendisliği Journal*, 444, 105-109.
- Shore, B., Venkatachalam, A. R., Solorzano, E., Burn, J. M., Hassan, S. Z., & Janczewski, L. J. (2001). Softlifting and piracy: Behavior across cultures. *Technology in Society*, 23(4), 563-581.
- Steinpreis, R. E., Anders, K. A., & Ritzke, D. (1999). The impact of gender on the review of the curricula vitae of job applicants and tenure candidates: A national empirical study. *Sex Roles*, 41(7/8), 509-528.
- Stuart, R. W. (1990). Impact of entrepreneurial and management experience on early performance. *Journal of Business Venturing*, 5(3), 151-162.
- Turhan, Ç., & Akman, I. (2013). Employability of IT graduates from the industry's perspective – A case study in Turkey. *Asia Pacific Education Review*, 14(4), 523-536. doi: 10.1007/s12564-013-9278-5
- Tübisad (2013). Bilgi ve iletişim teknolojileri sektörünün büyüklüğü 78,24 Milyar TL. Retrieved from http://www.tubisad.org.tr/Tr/MediaCenter/Sayfalar/sektor_verileri_2012_bulten.aspx.

THE USAGE OF SOCIAL MEDIA FOR LEARNING AND TEACHING PURPOSES: AN IMPLEMENTATION OF EXTENDED THEORY OF REASONED ACTION MODEL

İbrahim AKMAN
Atılım University
akman@atilim.edu.tr

Çiğdem TURHAN
Atılım University
cigdem_t@atilim.edu.tr

ABSTRACT: The growing popularity of the social networking sites has presented new options for the development of learning and teaching environments to provide informal learning. In this study, the usage of social networking sites for the purpose of learning and teaching has been analyzed using the extended Theory of Reasoned Action (TRA) model. A survey has been conducted to analyze the behavior in regard to the acceptance of social media for learning and teaching and the results were systematically analyzed with linear univariate and multivariate regression analysis techniques to apply the path analysis approach. The test results indicated that TRA has significant predictive power regarding the usage of social media for learning and teaching purposes. Among external variables, only PRB showed significant influence on the research model.

Key words: Social media, Social Networking, Informal learning, Theory of Reasoned Action

INTRODUCTION

From the early 2000's social networking sites (SNS) have emerged to establish a framework for creative expression, information sharing, interoperability and collaboration on the web such as Facebook, Twitter, Wikipedia, YouTube, etc. (Dabbagh & Kitsantas, 2012; Hong & Shaoi, 2012). According to the Global Digital Statistics, 1.8 billion people who use the Internet have social media accounts, worldwide. Whereas in Turkey, 45% of the population use the Internet, and 36 million active Facebook accounts exist (İnternet ve Sosyal Medya Kullanımı İstatistikleri, 2014). Furthermore, the report published by the Ministry of Youth and Sports states that the Internet usage rises to 76% in the 18-24 age range, and the users spend an average of 2 hours and 32 minutes on the social media (T.C.Gençlik ve Spor Bakanlığı, 2013).

This enormously popular infrastructure provides new opportunities for informal learning and teaching which can take place anywhere and anytime in the world. The users of the SNS can access learning and teaching systems in a personalized manner, voluntarily, based on their interests and are eager for the continuity of learning (Bull et al., 2008).

With the growing number of social learning environments, predicting and explaining the behavior of users regarding the adoption of SNS for their learning and teaching activities have gained importance for the acceptance, development and assessment of such systems. For this purpose, in this research, a survey was conducted to investigate user's behavior towards social learning systems, and the results were analyzed using the extended Theory of Reasoned Action (TRA) model which is a widely accepted tool to measure the user acceptance of new technology (Ajzen & Fishbein, 1980). For analysis, linear univariate and multivariate regression analysis techniques to apply the path analysis approach were utilized.

The remainder of the paper is arranged as follows. The next section introduces the research model, followed by the discussion on the external factors. Then, the research instrument and data are explained. In the next section, the descriptive and test results are presented which are followed by the conclusion.

RESEARCH MODEL

The objective of this paper is to analyse the adoption of social media for learning and teaching purposes based on the conceptual framework referred to as the Theory of Reasoned Action (TRA) (Ajzen & Fishbein, 1980). The TRA was specifically developed and used to predict and explain behavior of IT usage in the literature. The model has been proven to be successful in many of the IT studies from different perspectives (Godin et al., 2008; Marandu et al., 2010). For this reason, TRA has been chosen to assess individuals' actual behavior in

adopting social media for learning and teaching purposes (Figure 1). As can be seen from Figure 1, the basic TRA model contains “Attitude Towards Behavior (ATB)”, “Subjective Norms (SN)”, Behavioral Intention (BI)”, and “Actual Behavior (AB)” as its main constructs. On the other hand, Ajzen and Fishbein (1980) proposed to include external variables to make the theory more general. Additionally, as indicated by Burton-Jones and Hubona (2006), above mentioned traditional TRA constructs fully mediate the influence of external variables on usage behaviors. For this reason, we used two external constructs in our research model such as person related beliefs and level of awareness.

The present study performs a systematic analysis approach to investigate the significance of extended TRA to predict usage of social media for learning/teaching purposes. The extensions include Person Related Beliefs (PRB) and Level of Awareness (LA). The hypotheses were categorized according to the following empirical factors:

- External factors
- TRA constructs

The justification for empirical factors and their corresponding hypotheses is provided below.

External Factors

The factor belief has been studied in the context of usage of social media. In a recent study, Al-Gahtani (2011) stated that beliefs are salient factors in conceptual models and can be used to ascertain intentions. Kiraz and Ozdemir (2006) suggested that educational ideology may affect one’s decisions directly or indirectly since every individual has a belief system. They indicate in reference to O’Neill (1990) that educational ideologies are related to individuals’ beliefs with regard to the overall goals of education, the objectives of the school, the nature of the curriculum and instructional methods. Furthermore, it is known that perceptions about the usefulness of technology directly or indirectly affect the frequency of use of technology (Kiraz & Ozdemir, 2006). Based on this backdrop, we used Person Related Beliefs, which considers individual’s perceptions about the reliability, convenience and enjoyment in using social media to construct the following hypothesis:

H1: PRB has significant impact on ATB.

Awareness has been studied from different perspectives in ICT literature. For example, Hossain (2009) indicated that individuals with high awareness and skills have above-average computer experience and uses the internet more than others. This view is also supported by Aladwani (2003) that awareness regarding ICT issues such as internet security and ethics dominates the usage attitude. Humaidi and Balakrishnan (2012) also studied the influence of security awareness and concluded that this kind of awareness should be one of the significant factors in behavioural assessment of ICT usage. On the other hand, according to Taherdoost and Masrom (2009), having knowledge about a technology significantly affects the intention to adopt that technology and cause the users to enjoy its benefits. Suwannathachote (2012), who examined the relationship between teachers’ awareness and using SNS behaviors also supported this view. Finally, Taherdoost et al. (2011) studied awareness from ethical point of view and pointed out the existence of serious moral dilemmas due to lack of ethical awareness. All of these may be used as the indication of the importance of awareness for the assessment of actual behaviour towards adopting ICT. Additionally, to the best of our knowledge, none of the above literature inspected the social media usage behaviour in terms of learning and teaching purposes. Therefore, the following hypothesis is postulated.

H2: LA has significant impact on ATB.

The TRA is an important model for measuring user behavior as stated by Lee et al. (2006) and Wu and Liu (2007) since it provides a strong fit with the overall data (Ajzen & Fishbein, 1980). Different studies also mention the success of TRA over the other conceptual models such as Theory of Planned Behaviour (TPB) and Technology Acceptance Model (TAM) in studying general consumer information technologies and knowledge sharing (Peslak, 2012). Studies by Wu and Liu (2007) and Kwok and Gao (2006) are only two of the examples of such studies. One of the most important means of communication for many people at different ages today is social networking and Theory of Reasoned Action (TRA) has been utilized to investigate human behavior towards usage of social network sites (Peslak, et al., 2012). Based on this backdrop, we decided to use TRA for our main research model and constructed following hypotheses accordingly.

H3: There is a significant relationship between ATB and BI.

H4: There is a significant relationship between SN and BI.

H5: There is a significant relationship between BI and AB.

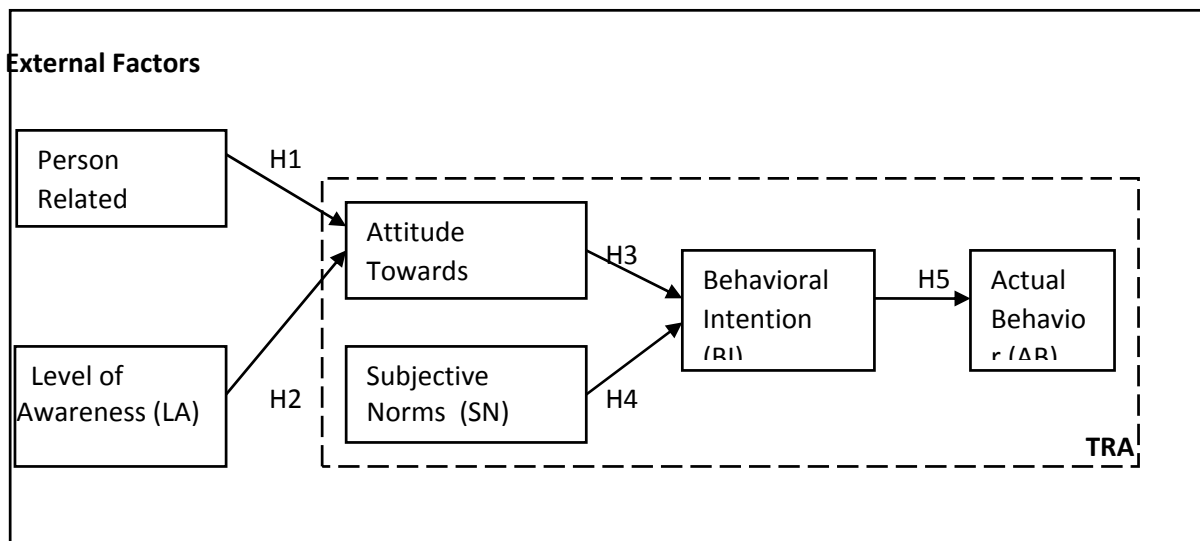

Figure

1. Research model. Boxes represent the constructs. The constructs inside dashed rectangle represents TRA, whereas others are extensions to TRA. Casual effects are given by arrows connecting boxes.

RESEARCH INSTRUMENT AND DATA

A survey was conducted to analyse the behaviour regarding adoption of Social Networking Sites (SNS) for learning and teaching (Figure 1). The data were obtained by means of a questionnaire containing 15 research questions grouped under 7 constructs according to TRA (Table 1). This questionnaire also included the variables gender (male, female) and age (<30, 31-40, 41-50 and >50) for descriptive analysis. Except for the descriptive variables, to be in parallel with the existing literature, 5-point Likert Scale (5=very much, 4=much, 3=moderate, 2=little, 1=very little) is used to collect data since this scale is the most widely used tool for survey-type studies (Table 1).

The data was collected during the 2nd International Engineering Education Conference, the 29th National Information Convention, and from various academicians and university students. A total of 142 completed survey questionnaires were obtained.

The linear univariate and multivariate regression analysis techniques were employed to apply Path analysis approach.

Table 1. List of Constructs and Corresponding Items

Construct/variable	Item
Gender	What is your gender? (Male, Female)
Age	What is your age? (< 21; 21-30; 31-40; 41-50; >50)
Subjective Norms (SN)	I think that most people who are important to me expect me to use social media for learning/teaching. I think that most people who are important to me use social media for learning/teaching.
Attitude Towards Behavior (ATB)	I have favourable attitude towards using social media for learning/teaching. Using social media is convenient for me in learning/teaching. Using social media is beneficial for me in learning/teaching.
Behavioral Intention (BI)	I intend to use social media for learning/teaching in the future. I intend to embed social media in my learning/teaching activities on a regular basis.
Actual Behavior (AB)	I use social media for learning/teaching. I use ICT (Inf. & Comm.Tech.) for learning/teaching.
Person related Beliefs (PRB)	Social media is a convenient support for my learning/teaching activities.

Social media is a reliable support for my learning/teaching activities.

I enjoy using social media for my learning/teaching activities.

Level of Awareness (LA)

In general, I believe I have awareness of social media issues.

I have awareness of social media.

I have awareness of online learning/teaching.

The cronbach's alpha (Brown, 2002) was used to assess reliability of the survey data. As a result, the overall internal reliability was found to be 0.698, which shows that the data exhibit reasonably high reliability (Yu, 2007).

RESULTS

Descriptive results

According to the descriptive results given in Table 2, of the males in the sample, 6% reported their awareness to be below average. Surprisingly, this percentage for females is only 2%. However, the test results do not indicate any significant difference for gender versus SNS awareness (Chi-Square = 2.858; DF = 3; P-Value = 0.414). Most of the respondents reported that they use SNS for learning and teaching activities at average level or higher (63%). The gender diversity for adoption of SNS for learning and teaching purposes was found to be significant (Chi-Square = 9.998; DF = 4; P-Value = 0.040). However, no significant diversity was observed for age in this regard.

The age distribution showed almost equal percentage for the male groups of below and above 30 years of age (49.49% and 50.51% resp.), whereas these percentages for females are 72.09% and 17.91% respectively. It is interesting to note that age and gender are negatively correlated ($r = -0.256$), meaning that female respondents are generally younger than males. Age also appears to be negatively correlated with social media usage for learning and teaching ($r = -0.268$). This may be used as an indication of the fact that younger respondents tend to use SNS for learning and teaching more than the older ones. Another interesting note is that the correlation between gender and using SNS for learning and teaching was found to be positive ($r = 0.214$) meaning that younger males use SNS more frequently for learning and teaching.

Table 2. Descriptive Statistics

Variable	Number	%
Gender	142	100
Male	99	70
Female	43	30
Unknown	-	-
Age	142	100
<30	80	56
31-40	26	18
41-50	24	17
>50	12	9
SNS usage for Learning/Teaching	142	100
Very often		
Often	29	20
Average	29	20
Less	32	23
Very less	26	18
Unknown	25	18
	1	1
Awareness level on SNS issues	142	100
Very high		
High	51	36
Average	53	37
Lows	27	19
Very low	5	5
Unknown	2	1
	3	2

Test Results

The proposed hypotheses based on the research model were tested using path analysis approach. The univariate and multivariate least-squares regression analysis techniques were used for that purpose and the pertaining results are given in Figure 2 along with their perspective path coefficients.

The inspection of p-values given in parantheses above the arrows in Figure 2 indicate that there is sufficient evidence to accept H1 ($p < 0.001$). This shows that person related beliefs have significant effect on attitude towards behaviour. This effect appears to be positive and its magnitude is 0.709. This means that increase in the personal beliefs regarding the convenience, reliability and enjoyment regarding SNS usage has an important effect on the attitude. The indirect effect of person related beliefs on behavioural intention is 0.11 ($0.701 * 0.155$). Interestingly, p-value for the relationship between level of awareness and ATB indicates that awareness does not influence the attitude and therefore we do not accept H2. This is probably because most of the respondents reported their SNS awareness to be higher than average (73%).

The regression test results provide sufficient evidence to accept hypothesis H3 since p-value was found to be significant at 0.1% significance level. Similarly, we accept H4 since the corresponding p-value is 0.039 ($p < 0.05$). These can be interpreted as attitude has positive predictive effect on behavioural intention for actual use of SNS for learning and teaching purposes since coefficient was found to be positive (coeff=0.155). On the other hand, interestingly, the regression coefficient for subjective norm was obtained to be negative (-0.170). The indirect effect of subjective norm on actual usage is -0.09 ($-0.170 * 0.526$) and significant. This may be interpreted as the other peoples opinion or behaviour increasingly effects an individual's behaviour on actual usage. Finally, inspection of p-value for the relationship between intention and actual behaviour is significant ($p\text{-value} = 0.000$) at 0.1% significance level and therefore we accept H5. The magnitude of the predictive effect is observed to be 0.526. This shows a strong predictive power of behavioural intention on actual usage of SNS for learning and teaching purposes.

All these can be summarized as, an increase in the individuals PRB and ATB will increase their intention and actual usage of SNS for learning and teaching purposes.

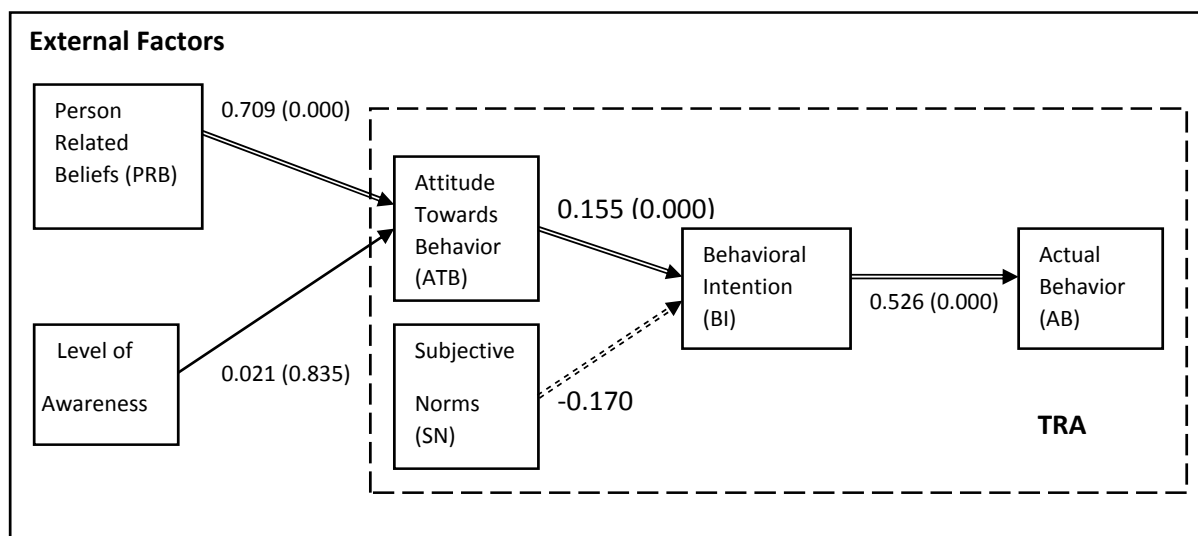

Figure 2. Test results. The path coefficients are given over the arrows. Double lines represent supported hypotheses for $p < 0.001$, double dashed lines represent supported hypotheses for $p < 0.05$ and single lines represent not supported.

CONCLUSION

Present study used a survey approach for the purpose of investigating the usage of SNS for learning and teaching purposes. The data was collected during the 2nd International Engineering Education Conference, the 29th National Information Convention from various academicians and university students. For the analysis, extended Theory of Reasoned action was used. Along with four traditional constructs of TRA (subjective norm, attitude towards behavior, behavioral intention and actual behavior), two external factors have been included in the analysis as extensions. The external factors are person related beliefs and level of awareness. The results

supported the predicted power of TRA and external factor PRB. However, LA does not show any direct or indirect significant influence on actual use of SNS for learning and teaching purposes.

REFERENCES

- Ajzen, I., & Fishbein, M. (1980). *Understanding Attitudes and Predicting Social Behavior*, Prentice-Hall, Englewood Cliffs, NJ.
- Al-Gahtani, S. S. (2011). Modeling the electronic transactions acceptance using an extended technology acceptance model. *Applied Computing and Informatics*, 9(1), 47-77.
- Aladwani, A.M. (2003). Key internet characteristics and e-commerce issues in Arab countries. *Information Technology and People*, 16(1), 9–20.
- Brown, J. D. (2002). The Cronbach alpha reliability estimate. *Shiken: JALT Testing & Evaluation SIG Newsletter*, 6(1), 17–19.
- Bull, G., Thompson, A., Searson, M., Garofalo, J., Park, J., Young, C., & Lee, J. (2008). Connecting informal and formal learning experiences in the age of participatory media. *Contemporary Issues in Technology and Teacher Education*, 8(2), 100-107.
- Burton-Jones, A., & Hubona, S. G. (2006). The mediation of external variables in the technology acceptance model. *Information & Management*, 43, 706–717.
- Dabbagh, N. & Kitsantas, A. (2012). Personal learning environments, social media, and self-regulated learning: A natural formula for connecting formal and informal learning. *Internet and Higher Education*, 15, 3-8.
- Godin, G., Gravel, A. B., Eccles, M., & Grimshaw, J. (2008). Healthcare professionals' intentions and behaviours: A systematic review of studies based on social cognitive theories. *Implementation Science*, 3:36, 1-12.
- Hong, R. And Shaoi L. (2012). Learning from social media network. Editorial, *Neurocomputing*, 95, 1-2.
- Hosein, N. Z. (2009). Internet banking: An empirical study of adoption rates among midwest community banks. *Journal of Business & Economics Research*, 7(11), 51-72.
- Humaidi, N. & Balakrishnan, W. (2012). The influence of security awareness and security technology on users' behavior towards the implementation of health information system: A conceptual framework. *2nd International Conference on Management and Artificial Intelligence IPEDR*, 35, 1-6.
- Internet ve Sosyal Medya Kullanıcı İstatistikleri.(2014). DijitalAjanslar. Retrieved March 10, 2014 from <http://www.dijitalajanslar.com/internet-ve-sosyal-medya-kullanici-istatistikleri-2014/>.
- Kiraz, E. and Ozdemir, D. (2006). The relationship between educational ideologies and technology acceptance in preservice teachers. *Educational Technology & Society*, 9 (2), 152-165.
- Kwok, S. H., & Gao, S. (2005/2006). Attitude towards knowledge sharing behavior. *The Journal of Computer Information Systems*, 46(2), 45-51.
- Lee, S.-F., Tsai, Y.-C., & Jih, W.-J. (2006). An empirical examination of customer perceptions of mobile advertising. *Information Resources Management Journal*, 19(4), 39-55.
- Marandu, E. E., Moeti, N., & Joseph, H. (2010). Predicting residential water conservation using the theory of reasoned action. *Communication*, 1(2), 87-100.
- O'Neill, W. F. (1990). *Educational Ideologies Contemporary Expressions of Educational Philosophy*. Dubuque,Iowa: Kendall / Hunt Publishing Company (Original work published 1981).
- Peslak, A., Ceccucci, W. & Sendall, P. (2012). An empirical study of social networking behavior using theory of reasoned action, *Journal of Information Systems Applied Research (JISAR)*, 5(3), 12-23.
- Suwannatthachote, P. (2012). Exploring pre-service teachers' awareness on using social networking sites: are they ready for digital citizenship? *Revista De Informática Aplicada*, 8(1),41-48.
- Taherdoost, H., Jalaliyoon, N., Namayandeh, M., Forghani, A. & Zamani, M. (2011). Adoption framework expansion based on the computer ethics' related research models and ethical scenarios analysis. *2010 International Conference on Economics, Business and Management, IPEDR vol.2*, 219-223.
- Taherdoost, H. & Masrom, M. (2009). An examination of smart card technology acceptance using adoption model. *Proceedings of the 31st International Conference on Information Technology Interfaces (ITI), IEEE*, 329-334.
- T.C. Gençlik ve Spor Bakanlığı. (2014). *Gençlik ve Sosyal Medya Araştırma Raporu*. Retrieved March 5, 2014 from http://genclikarastirmalari.gsb.gov.tr/dergi/sosyal_medya_raporu/.
- Wu, J., & Liu, D. (2007). The effects of trust and enjoyment on intention to play online games. *Journal of Electronic Commerce Research*, 8(2), 128-140.
- Yu, A. (2007). Assess students: Item analysis. *Instructional Assessment Resources, IAR*, Retrieved from <http://www.utexas.edu/academic/diia/assessment/iar/students/report/itemanalysis.php>.

FEN BİLİMLERİ ÖĞRETMEN ADAYLARININ GİRİŞİMCİ ÖZELLİKLERİNİN BAZI DEĞİŞKENLER AÇISINDAN İNCELENMESİ

EXAMINING SCIENCE TEACHER CANDIDATES' ENTREPRENEURIAL CHARACTERISTICS IN TERMS OF SOME VARIABLES IN TURKEY

İsa DEVECİ
Uludağ Üniversitesi
deveciisa@gmail.com

Salih ÇEPNİ
Uludağ Üniversitesi
cepnisalih@yahoo.com

ÖZET: Bu araştırmada fen bilimleri öğretmen adaylarının sınıf düzeyi, cinsiyet, iş deneyimi ve herhangi bir dalda alınan ödül açısından girişimci özelliklerinin farklılık gösterip göstermediği incelenmiştir. Araştırma verileri beş farklı üniversitede eğitim gören 963 fen bilimleri öğretmen adaylarından elde edilmiştir. Veriler araştırmacılar tarafından geliştirilen beş faktörden oluşan (risk alma, kendine güven, fırsatları görme, duygusal zeka ve yenilikçi olma) beşli Likert tipi ölçme aracı ile toplanmış ve Kolmogorov-Simironov Testi, U Testi ve H Testi ile analiz edilmiştir. Analiz sonuçlarına göre; cinsiyet değişkeni açısından risk alma ve yenilikçi olma özelliklerinde erkekler lehine, iş deneyimi değişkeni açısından risk alma, duygusal zeka, fırsatları görme ve yenilikçi olma özelliklerinin iş deneyimi olanlar lehine, ödül alma değişkeni açısından ise risk alma, kendine güven, fırsatları görme ve yenilikçi olma özelliklerinin ödül almış olanlar lehine anlamlı sonuçlar elde edilmiştir. Ayrıca sınıf düzeyi açısından sadece yenilikçi olma boyutunda dördüncü sınıf öğrencilerinin diğer sınıf düzeylerine göre daha yenilikçi özelliklere sahip oldukları görülmektedir.

Anahtar sözcükler: Öğretmen Eğitimi, Fen bilimleri Öğretmen Adayları, Girişimci Özellikler

ABSTRACT: The purpose of this study was to determine science teacher candidates' entrepreneurial characteristics in terms of grade levels, genders, Work Experiences and prizes in any field taken. The sample consist of 963 science teacher candidates' enrolled in science education department during the fall semester 2013 at five universities. Data were gathered through a entrepreneurial scale developed by the researchers that is compose of five sub-scale: risk-taking, self-confidence, see opportunities, emotional intelligence and be innovative. Findings showed that there were a significant differences among the dependent variables risk-taking and be innovative in terms of gender. According to work experience, it was found that there were also a significant differences among the dependent variables risk-taking, self-confidence, emotional intelligence and be innovative. Moreover, according to prizes taken in any field, it was found that there were a significant differences among the dependent variables risk-taking, self-confidence, see opportunities and be innovative. Moreover, It was found that senior teacher candidates in grade level category had higher subscales scores than freshman, sophomore, junior teacher candidates' in terms of grade level.

Key words: Teacher Education, Science Teacher Candidates, Entrepreneurial Characteristics

ÖĞRENCİLERİN ÖĞRENME YAKLAŞIMLARI İLE DÜŞÜNME STILLERİ ARASINDAKİ İLİŞKİNİN İNCELENMESİ

THE EXAMINATION OF RELATIONS BETWEEN STUDENTS' LEARNING APPROACH AND THINKING STYLE

Agah Tuğrul KORUCU
Necmettin Erbakan Üniversitesi
agah.korucu@gmail.com

Yusuf Ziya OLPAK
Ahi Evran Üniversitesi
yusufziyaolpak@gmail.com

Özet: Günümüzde bilgi ve iletişim teknolojilerinde gerçekleşen gelişmeler, eğitim alanında ki bilgi miktarlarında ve teknoloji kullanımına büyük miktarda katkı sağlamaktadır. Bu gelişime ayak uydurabilmek için, öğrencilerin öğrenmeye ihtiyaçları vardır ve ihtiyaç duydukları bilgileri öğrenebilmeleri gerekmektedir. İhtiyaç duyulan bilgiye ulaşmada önemli olan değişkenlerden birisi düşünme stiliyen bir diğeri öğrenme yaklaşımıdır. Öğrenme yaklaşımı; ihtiyaç duyulan öğrenmeyi gerçekleştirmek için gözetilen amaç ve seçilebilecek etkinliklerdeki farklılaşmadır. Öğrenme yaklaşımı öğrencilerin ders çalışırken kullandıkları stratejileri ve bu stratejileri seçme amaçlarını kapsamaktadır. Öğrenme yaklaşımının, öğrenci başarısını doğrudan etkilemesinden dolayı yaşam boyu öğrenme sürecinde de önemli ölçüde etkisi olan değişkenlerden bir tanesidir. Öğrenme yaklaşımları, “derin öğrenme” ve “yüzeysel öğrenme” olarak ifade edilebilmektedir. Bu çalışmanın amacı, ön lisans programlarındaki öğrencilerin öğrenme yaklaşımlarının belirlenmesi ve düşünme stilleri ile olan ilişkisinin incelenmesidir. Tarama modeline göre yürütülen bu araştırma, kullanılan veri toplama araçlarındaki sorulara uygun şekilde yanıtlar veren 234 ön lisans öğrencisinden elde edilen veriler ile gerçekleştirilmiştir. Verilerin toplanmasında Yılmaz ve Orhan (2011) tarafından Türkçe’ye uyarlanan ders çalışma yaklaşımı ölçeği, Sünbül (2004) tarafından Türkçe’ye uyarlanan düşünme stilleri ölçeği ve yazarlar tarafından geliştirilen kişisel bilgi formu kullanılmıştır. Elde edilen verilerin çözümlenmesinde SPSS (The Statistical Package for The Social Sciences) paket programı kullanılmıştır. Verilerin çözümlenmesinde ise; betimsel istatistikler ve basit korelasyon kullanılmıştır.

Anahtar kelimeler: öğrenme yaklaşımı, derin yaklaşım, yüzeysel yaklaşım, düşünme stili.

Abstract: Today developments in information and communication technologies contribute to information amount and using technology very much. So as to keep in step with this development students need learn and it is need that they should learn the information they need. While one of the variables that required in reaching the information is thinking style the other one is learning approach. Learning approach is differentiation in activity and aim to realize the learning which is need. Learning approach include the strategies which are used by students while studying and their aims in choosing these strategies .Learning approach affects student’s success directly so it is one of the variables which has a great effect in life-long learning process. Learning approaches are explained as “deep learning” and “surface learning”. The aim of this studying is determining the learning approaches of pre-licensing students’ and examining the connection with thinking styles. The research carried out according to survey model was realized with data from the 234 pre-licensing who answer the questions conveniently in data collection tools. The study process questionnaire adapted to the Turkish language by Yılmaz and Orhan (2011), thinking styles scale adapted Turkish language by Sünbül (2004), personal information form developed by writers was used in collection of data. In analyzing of data SPSS (the Statistical Package for the Social Sciences) packet program was used. In analyzing the data descriptive statistics and simple correlation was used.

Key Words: learning approach, deep approach, surface approach, thinking style.

GİRİŞ

21. yüzyıl gelişmeleri ve gereksinimleri, bilim ve teknoloji alanındaki gelişmeleri de önemli anlamda etkileyerek, birey yaşamının her alanında olduğu gibi eğitim alanının da gelişmesine yol göstermektedir. Bu etkilere paralel olarak eğitimde bu değişimden önemli ölçüde katkı görmektedir. Öğretim teknolojilerinin 21. yüzyıl gelişmelerine paralel olarak gelişmesi, bireylerin öğrenmeye olan ihtiyaçlarını etkilemiş ve ihtiyaç duydukları bilgileri öğrenebilmelerine yeni olanaklar sağlamıştır. İhtiyaç duyulan bilgiye ulaşmada önemli olan değişkenlerden birisi düşünme stiliyen bir diğeri öğrenme yaklaşımıdır.

Yılmaz ve Orhan (2011), Entwistle ve McCune (2004) ve Prosser ve Trigwell (1999) tarafından yapılan çalışmalardan yararlanarak, öğrenme yaklaşımının; belirli bir öğrenme işini gerçekleştirmek için gözetilen amaç ve seçilebilecek etkinliklerdeki farklılaşmayı ifade etmekte olduğunu ve öğrencilerin ders çalışırken kullandıkları stratejileri ve bu stratejileri seçme amaçlarını kapsadığını belirtmiştir. Ayrıca öğrencilerin öğrenme yaklaşımlarının, “derin öğrenme” ya da “yüzeysel öğrenme” şeklinde olduğunu ve alanyazında görülen “derin yaklaşım” ve “yüzeysel yaklaşım” ifadelerinin de aynı kavramı tanımladığını belirtmişlerdir.

Abraham, Vinod, Kamath, Asha ve Ramnarayan (2008) tarafından yapılan çalışmada; öğrencilerin öğrenme yaklaşımlarının belirlenmesinin; öğrencileri daha iyi öğrenenler haline getirmede yardımcı olma, kendi öğretiminin etkinliğini izlemek ve geliştirmek isteyen akademisyenlere yardımcı olma, etkisiz stratejilerden dolayı risk altındaki öğrencileri belirleme ile öğrenme deneyimi ve çıktılarını gözlemlene açısından önemli olduğu belirtilmiştir.

Alanyazın tarandığında öğrenme yaklaşımı ile ilgili yurtdışında çok fazla çalışma yapılmasına karşın, ülkemizde bu konuda yeteri kadar çalışma yapılmadığı göze çarpmaktadır. Ayrıca, ülkemizde yapılan çalışmalarda daha çok öğretmen adaylarının öğrenme yaklaşımları üzerinde durulmuştur (Çuhadar, Gündüz ve Tanyeri, 2013; Ellez ve Sezgin, 2002; Karadeniz Bayrak ve Erkoç, 2008; Ozan ve Çiftçi, 2013; Ozan, Köse ve Gündoğdu, 2012; Özgür ve Tosun, 2012; Senemoğlu, 2011; Sezgin Selçuk, Çalışkan ve Erol, 2007; Şahin Taşkın, 2012). Bu çalışmalarda öğretmen adaylarının öğrenme yaklaşımının; cinsiyete, sınıf düzeyine, anabilim dalına/bölüme ve öğretme-öğrenme ortamı algısına göre anlamlı bir farklılık gösterip göstermediği incelenmiştir. Ek olarak, öğrenme yaklaşımı ile akademik başarı, öğrenme yaklaşımı ile biliş üstü algı, öğrenme yaklaşımı ile akademik öz-yeterlilik algısı arasındaki ilişki araştırılmış ve öğrencilerin öğrenme yaklaşımlarının yordayıcısı olarak epistemolojik inançları ile ilgili çalışılmıştır. Öğrenme yaklaşımı ile ilgili daha fazla değişken hakkında bilgi sahibi olabilmek için, çeşitli değişkenlerin/bireysel farklılıkların dikkate alındığı çalışmaların yapılması da önerilmiştir (Özgür ve Tosun, 2012; Şahin Taşkın, 2012).

Olpak ve Korucu (2014) tarafından yapılan çalışmada ise; önlisans programlarındaki öğrencilerin ders çalışma yaklaşımlarının belirlenmesi ve farklı değişkenler (cinsiyet, yaş, sınıf, bölüm ve akademik genel not ortalaması) ile olan ilişkisinin incelenmesi amaçlanmıştır. Özellikle sanayinin ihtiyaç duyduğu ara eleman ihtiyacını karşılamak için belirli bir mesleğe yönelik eğitim veren meslek yüksekokullarından yetişen ön lisans öğrencilerinin, 21. yüzyıl gereksinimlerine uygun niteliklerle sahip olabilmeleri için, öğretim uygulamalarından en iyi şekilde yararlanabilmeleri gerekmektedir. Ancak kapsamlı olarak gerçekleştirilen alanyazın taramasından da görülebileceği gibi ülkemizde bu alanda yapılan çalışmalar oldukça yetersizdir. Bu bağlamda bu çalışma kapsamında öğrencilerin öğrenme yaklaşımları ile ilgili daha fazla değişken hakkında bilgi sahibi olabilmek için, öğrenme yaklaşımı ile düşünme stili arasındaki ilişki incelenmiştir.

Düşünme stilleri, bireylerin karşılaştıkları çeşitli problemlere, olaylara, olgulara ve değişkenlere karşı düşünme süreçleri sonucu göstermiş oldukları yaklaşım ve eğilimlerdir (Başol ve Türkoğlu, 2009; Emir, 2013; Mingchang, Shihuei, Hsiuhsu, Chang ve Lihua, 2013; Tortop, Çalışkan ve Dinçer, 2013). Düşünme stilleri, bireyin bilgiyi nasıl aldığı ve işlediğiyle yakından ilgilidir. Bir bireylerin her bir düşünme stilini içinde bulunduran bir düşünme stili profili vardır ancak, bireyler sadece bir düşünme stiline bağlı değildir. Farklı görev ve durumlara uyum sağlamak amacıyla düşünme stilleri değişiklik gösterebilir (Sünbül, 2004). Sternberg tarafından geliştirilen “zihinsel olarak kendi kendini yönetme” (mental self-government) yaklaşımında temel görüş, bireyin yaygın olan yönetim türleriyle (kuralcı, yetkili, yargısal, monarşik, hiyerarşik, oligarşik) benzer bir şekilde kendi içinde düşünme stillerini oluşturması ve kendisini yönetmesidir. Sternberg’in yaklaşımında, işlevler, biçimler, düzeyler, kapsam ve eğilimler olmak üzere 5 kategori altında toplam 13 düşünme stili vardır. Düşünme stili, bireyin yeteneklerini kullanmada seçmiş olduğu yöntemdir. Bu nedenle, çeşitli olan düşünme stilleri iyi veya kötü değil, sadece farklıdır (Sternberg, 1994). Düşünme stilleri kapsam açısından: içe dönük düşünenler ve dışa dönük düşünenler olarak ikiye ayrılmaktadır. İçe dönük düşünenler; yalnız başına çalışmayı seven, kendi içinde yoğunlaşıp, kendi kendine yetmekteyken; dışa dönük düşünenler ise, başkalarıyla çalışmayı seven, dışarı yoğunlaşıp, kişilerle ilişki kurmaktan hoşlanmaktadırlar (Sünbül, 2004). Bu bağlamda bu çalışma kapsamında, ortaya koyulmuş 13 düşünme stili içerisinde, kapsam açısından; içe dönük ve dışa dönük olarak nitelendirilmiş olan düşünme stiline, öğrenme yaklaşımı ile ne şekilde ilişkili olduğunu ortaya koymak amaçlanmaktadır. Buradan hareketle bu çalışmanın amacı, ön lisans programlarındaki öğrencilerin öğrenme

yaklaşımlarının belirlenmesi ve düşünme stilleri ile olan ilişkisinin incelenmesidir. Bu genel amaç çerçevesinde aşağıdaki sorulara cevap aranmıştır.

1. Öğrencilerin öğrenme yaklaşımı nedir?
2. Öğrencilerin düşünme stili nedir?
3. Öğrencilerin öğrenme yaklaşımları ile düşünme stilleri arasında anlamlı bir ilişki var mıdır?

YÖNTEM

Araştırmanın Modeli ve Çalışma Grubu

Tarama modeline göre yürütülen bu araştırma, 2013-2014 eğitim-öğretim yılı bahar döneminde, Ahi Evran Üniversitesi Mucur Meslek Yüksekokulu'ndaki kayıtlı 1093 öğrenciden, araştırma kapsamında kullanılan veri toplama araçlarındaki sorulara uygun şekilde yanıtlar veren 234 öğrenciden elde edilen veriler ile gerçekleştirilmiştir. Çalışma grubundaki öğrencilerin cinsiyet, bölüm ve sınıf düzeyine göre dağılımına ilişkin bilgiler Tablo 1'de verilmiştir.

Tablo 1. Çalışma Grubundaki Öğrencilerin Cinsiyete, Okudukları Bölüme ve Sınıf Düzeyine Göre Dağılımları

Değişkenler		N	%
Cinsiyet	Erkek	113	48.29
	Kadın	121	51.71
	Toplam	234	100
Bölüm	Bilgisayar Teknolojileri	131	55.98
	Görsel, İşitsel Teknikler ve Medya Yapımcılığı	17	7.26
	Muhasebe ve Vergi Uygulamaları	21	8.97
	Tasarım	49	20.94
	Yönetim ve Organizasyon	16	6.84
	Toplam	234	100
Sınıf	1. Sınıf	101	43.16
	2. Sınıf	133	56.84
	Toplam	234	100

Tablo 1'de de görüldüğü gibi, çalışma grubundaki 234 öğrenciden; 113'ü (%48.29) erkek, 121'i ise kadındır (%51.71). Öğrencilerin; 131'i "Bilgisayar Teknolojileri", 17'si "Görsel, İşitsel Teknikler ve Medya Yapımcılığı", 21'i "Muhasebe ve Vergi Uygulamaları", 49'u "Tasarım" ve 16'sı da "Yönetim ve Organizasyon" bölümlerinde öğrenim görmektedirler. Ayrıca, öğrencilerin 101'i 1. sınıfta, 133'ü de 2. sınıfta öğrenim görmektedirler.

Veri Toplama Araçları

Araştırma kapsamında verilerin toplanmasında Yılmaz ve Orhan (2011) tarafından Türkçe'ye uyarlanan ders çalışma yaklaşımı ölçeği, Sünbül (2004) tarafından Türkçe'ye uyarlanan düşünme stilleri ölçeği ve yazarlar tarafından geliştirilen kişisel bilgi formu kullanılmıştır.

Yılmaz ve Orhan (2011) tarafından yapılan çalışmanın amacı; Biggs, Kember ve Leung (2001) tarafından üniversite öğrencilerine yönelik geliştirilmiş olan ders çalışma yaklaşımı ölçeğinin Türkçe formunun; dilsel eşdeğerliliğinin, geçerliliğinin ve güvenilirliğinin incelenmesidir. Ölçekte toplam 20 madde ve derin ve yüzeysel yaklaşım olmak üzere de iki boyut bulunmaktadır. Ayrıca bu iki boyutun altında da ayrı ayrı olmak üzere motivasyon ve strateji alt boyutları bulunmaktadır. Maddelerin cevaplanmasında ise beşli Likert tipi derecelendirme kullanılmış ve her bir madde için; "benim için asla geçerli değil ya da nadiren geçerli (1)", "benim için bazı zamanlar geçerli (2)", "benim için yarı yarıya geçerli (3)", "benim için sıklıkla geçerli (4)" ve "benim için her zaman ya da hemen hemen her zaman geçerli (5)" seçenekleri sunulmuştur. Geçerlilik çalışması sonuçlarına göre; derin motivasyon, derin strateji, yüzeysel motivasyon ve yüzeysel strateji alt boyutlarının varlığını öngören özgün yapıya Türkçe ölçekte ulaşılabilmiştir. Ancak Türkçe ölçeğin bireylerin derin ve yüzeysel yaklaşımlardan hangisini benimsediklerini geçerli bir şekilde ölçebileceği belirtilmiştir. Ayrıca Biggs ve diğerleri (2001) ölçeğin sadece derin ve yüzeysel yaklaşımı ölçmek için de kullanılabileceğini belirtmiştir. Ölçeğin Türkçe formunun ölçmedeki kararlılığını test etmek için test-tekrar test yönteminden yararlanılmış ve elde edilen sonuçlar ölçeğin iki uygulaması arasındaki tutarlılığın kabul edilebilir düzeyde olduğunu göstermiştir. Ayrıca ölçeğin iç tutarlılığını belirlemek için hesaplanan Cronbach α güvenilirlik katsayısı; derin yaklaşım için .79 ve yüzeysel yaklaşım için ise .73'tür.

Sünbül (2004) tarafından Türkçe'ye uyarlanan düşünme stilleri ölçeği 94 maddeden oluşmaktadır. Maddelerin cevaplanmasında ise beşli derecelendirme kullanılmış ve her bir madde için; "Her zaman (1)", "Sık sık (2)",

“Bazen (3)”, “Nadiren (4)” ve “Hiçbir zaman (5)” seçenekleri kullanılmıştır. Öğrencilerin düşünme stillerini belirlemeye yönelik düşünme stilleri ölçeğinde 13 temel düşünme stili temele alınmıştır. Bu düşünme stilleri sırasıyla; Öznel düşünme, kuralcı düşünme, yargılayıcı düşünme, tekilci, aşamalı, eş değerci, kuralsız, bütüncül düşünme, ayrıntıcı düşünme, kendine özgü, dışa dönük, yenilikçi ve gelenekçi düşünme stilleridir. Yapı geçerliği çalışması faktör (temel birleşenler) analizi yöntemi uygulanarak gerçekleştirilmiştir. Yayınlanan ölçekte yer alan maddelerin seçiminde değişim (Varimax) sonrası faktör analizi ile, madde test ve madde kalan korelasyonları temele alınmıştır. Bu çalışmalar sonucunda ölçeğin 13 boyutunun ve açıklanan varyans miktarının yeterli olduğu ayrıca her bir maddenin değişim öncesi ve sonrası faktör yükleri ile madde-alt test ve madde kalan korelasyonlarının yeterli düzeyde olduğu doğrulanmıştır. 13 faktörün birlikte açıkladığı varyans %51,027’dir. Yayınlanan ölçekte alınan tüm maddelerin faktör yükü 0,40’ın üstündedir. Ayrıca ölçeğin iç tutarlılığını belirlemek için hesaplanan Cronbach α güvenilirlik katsayısı; tüm alt ölçekler için 0,70 ile 0,861 arasında değişmektedir.

Verilerin Çözümlemesi

Araştırma kapsamında elde edilen veriler SPSS (The Statistical Package for The Social Sciences) paket programı kullanılarak çözümlenmiştir. Öğrencilerin öğrenme yaklaşımlarının ve düşünme stillerinin belirlenmesinde betimsel istatistiklerden yararlanılmıştır. Öğrencilerin; öğrenme yaklaşımları ile düşünme stilleri arasındaki ilişkinin belirlenmesinde ise, basit korelasyon tekniğinden yararlanılmıştır.

BULGULAR

Öğrencilerin öğrenme yaklaşımlarına yönelik bulgular:

Araştırma sonucunda toplanan veriler ile yapılan istatistik testlerinin sonucunda, çalışma grubundaki 234 öğrencinin ders çalışma yaklaşımı ölçeğinden aldıkları puanlar; 135’inin derin yaklaşıma, 99’unun ise yüzeysel yaklaşıma sahip olduğunu göstermiştir.

Öğrencilerin düşünme stillerine yönelik bulgular:

Araştırma sonucunda toplanan veriler ile yapılan istatistik testlerinin sonucunda, çalışma grubundaki 234 öğrencinin düşünme stilleri ölçeğinden aldıkları puanlar; 136’sının dışa dönük, 98’inin ise içe dönük olduğunu göstermiştir.

Öğrencilerin öğrenme yaklaşımları ile düşünme stilleri arasındaki ilişkiye yönelik bulgular:

Bu araştırma kapsamında öğrencilerin derin ve yüzeysel öğrenme yaklaşımı yaklaşımları ile içe dönük ve dışa dönük düşünme stillerinin arasındaki ilişkinin belirlenmesinde basit korelasyon tekniğinden yararlanılmıştır. Korelasyon iki değerle ifade edilebilen bir büyüklüktür. Bu değerlerden birisi korelasyonun yönü iken diğeri büyüklüğüdür. Korelasyon katsayısının 1.00 olması, mükemmel pozitif bir ilişkiyi; -1.00 olması, mükemmel negatif bir ilişkiyi; 0.00 olması ise ilişkinin olmadığını gösterir. Alanyazında korelasyon katsayısının büyüklük bakımından yorumlanmasında tam olarak bir fikir birliği olmamakla beraber; korelasyon katsayısının mutlak değerinin 0.70-1.00 arasında olması, yüksek; 0.70-0.30 arasında olması, orta ve 0.30-0.00 arasında olması ise, düşük düzeyde bir ilişki olarak tanımlanabilir (Büyüköztürk, 2011:32).

Öğrencilerin ders çalışma yaklaşımı ölçeğinin derin yaklaşım boyutundan aldıkları puanlar ile içe dönük ve dışa dönük düşünme stilleri arasındaki ilişkiye dair bulgular Tablo 2’de verilmiştir.

Tablo 2. Derin Öğrenme Yaklaşımı ile İçe Dönük ve Dışa Dönük Düşünme Stilleri Arasındaki İlişki

Düşünme Stili	Derin Öğrenme Yaklaşımı
İçe dönük	.283*
Dışa dönük	.283*

*Korelasyon 0.01 düzeyinde anlamlıdır.

Tablo 2’de de görüldüğü gibi, derin öğrenme yaklaşımı ile içe dönük düşünme stili arasında düşük düzeyde, pozitif yönlü ve anlamlı bir ilişki bulunmaktadır. Ayrıca, derin öğrenme yaklaşımı ile dışa dönük düşünme stili arasında da düşük düzeyde, pozitif yönlü ve anlamlı bir ilişki bulunmaktadır.

Öğrencilerin ders çalışma yaklaşımı ölçeğinin yüzeysel yaklaşım boyutundan aldıkları puanlar ile içe dönük ve dışa dönük düşünme stilleri arasındaki ilişkiye dair bulgular Tablo 3’te verilmiştir.

Tablo 3. Yüzeysel Öğrenme Yaklaşımı ile İçe Dönük ve Dışa Dönük Düşünme Stilleri Arasındaki İlişki

Düşünme Stili	Yüzeysel Öğrenme Yaklaşımı
---------------	----------------------------

İçer dönük	.934*
Dışar dönük	.056*

*Korelasyon 0.01 düzeyinde anlamlıdır.

Tablo 3'te de görüldüğü gibi, yüzeysel öğrenme yaklaşımı ile içer dönük düşünme stili arasında yüksek düzeyde, pozitif yönlü ve anlamlı bir ilişki bulunmaktadır. Ayrıca, yüzeysel öğrenme yaklaşımı ile dışar dönük düşünme stili arasında da düşük düzeyde, pozitif yönlü ve anlamlı bir ilişki bulunmaktadır.

SONUÇ

Bu araştırma sonucunda, çalışma grubundaki 234 öğrencinin ders çalışma yaklaşımı ölçeğinden aldıkları puanlar; 135'inin derin yaklaşıma, 99'unun ise yüzeysel yaklaşıma sahip olduğunu göstermiştir. Öğrencilerin düşünme stilleri ölçeğinden aldıkları puanlar ise; 136'sının dışar dönük, 98'inin ise içer dönük olduğunu göstermiştir. Öğrencilerin derin öğrenme yaklaşımı ile içer dönük düşünme stili arasında düşük düzeyde, pozitif yönlü ve anlamlı bir ilişki varken; derin öğrenme yaklaşımı ile dışar dönük düşünme stili arasında da düşük düzeyde, pozitif yönlü ve anlamlı bir ilişki bulunmaktadır. Ayrıca, öğrencilerin, yüzeysel öğrenme yaklaşımı ile içer dönük düşünme stili arasında yüksek düzeyde, pozitif yönlü ve anlamlı bir ilişki varken; yüzeysel öğrenme yaklaşımı ile dışar dönük düşünme stili arasında da düşük düzeyde, pozitif yönlü ve anlamlı bir ilişki bulunmaktadır.

ÖNERİLER

Araştırma sonucunda ulaşılan bulgular ışığında, öğrencilerin daha büyük bir bölümünün öğrenme konusunda derin yaklaşıma sahip olabilmeleri için öğretim elemanlarının; daha öğrenci merkezli öğrenme ortamları sunmaları, yüzeysel yaklaşıma sahip öğrencilere derin yaklaşıma uygun stratejileri kullanmaları yönünde rehberlik etmeleri ve öğrenme ortamındaki etkinlikleri başarabilecekleri yönünde öğrencileri motive etmeleri önerilmektedir. Ayrıca, öğrencilerin bireysel farklılıklarının dikkate alındığı dersler tasarlanmalı ve derslerin tasarımında çeşitlilik oluşturularak öğrencilerin derse daha aktif katılımlarının sağlandığı, akademik uğraşlarının daha da artırıldığı, derse karşı daha çok ilgilerinin sağlandığı bir ortam oluşturulmalıdır.

Bu araştırma bir tek meslek yüksekokulunda öğrenim gören öğrenciler üzerinde yürütülmüştür. Bu nedenle, araştırma bulgularının genellenebilmesi için, farklı meslek yüksekokullarında öğrenim gören öğrencilerin de yer aldığı, daha geniş çaplı araştırmalar yapılması önerilmektedir. Ayrıca ileride yapılacak araştırmalarda; farklı eğitim düzeylerindeki (önlisans, lisans vb.) öğrencilerin çeşitli bireysel farklılıklarının da dikkate alındığı çalışmaların yapılması, öğrenme yaklaşımı ile ilgili daha fazla değişken hakkında bilgi sahibi olunmasını sağlayacağından önemli görülmektedir.

KAYNAKLAR

- Abraham, R. R., Vinod, P., Kamath, M. G., Asha, K., & Ramnarayan, K. (2008). Learning approaches of under graduate medical students to physiology in a non-PBL and partially PBL-oriented curriculum. *Advances in Physiology Education*, 32(1), 35–37.
- Biggs, J., Kember, D., & Leung, D. Y. P. (2001). The revised two-factor study process questionnaire: R-SPQ-2F. *British Journal of Educational Psychology*, 71(1), 133–149.
- Başol, G., & Türkoğlu, E. (2009). Sınıf öğretmeni adaylarının düşünme stilleri ile kontrol odağı durumları arasındaki ilişki. *Uluslararası İnsan Bilimleri Dergisi*, 6(1).
- Büyüköztürk, Ş. (2011). *Sosyal bilimler için veri analizi el kitabı*. Ankara: PegemA Yayıncılık (14. baskı., p. 201).
- Çuhadar, C., Gündüz, Ş., & Tanyeri, T. (2013). Bilgisayar ve öğretim teknolojileri eğitimi bölümü öğrencilerinin ders çalışma yaklaşımları ve akademik öz-yeterlik algıları arasındaki ilişkinin incelenmesi. *Mersin Üniversitesi Eğitim Fakültesi Dergisi*, 9(1), 251–259.
- Ellez, A. M., & Sezgin, G. (2002). Öğretmen adaylarının öğrenme yaklaşımları. *Orta Doğu Teknik Üniversitesi V. Ulusal Fen Bilimleri ve Matematik Eğitimi Kongresi*, 16-18 Eylül. Ankara.
- Emir, S. (2013). Contributions of teachers' thinking styles to critical thinking dispositions (Istanbul-Fatih Sample). *Educational Sciences: Theory & Practice*, 13(1).
- Entwistle, N., & McCune, V. (2004). The conceptual bases of study strategy inventories. *Educational Psychology Review*, 16(4), 325–345.
- Karadeniz Bayrak, B., & Erkoç, M. F. (2008). BÖTE bölümü öğrencilerinin bilişüstü algılarını etkileyen faktörler ve bilişüstü algıların öğrenme yaklaşımlarıyla ilişkisi. *8th International Educational Technology Conference, Anadolu University*, Eskişehir.
- Mingchang, W. U., Shihuei, H. O., Hsiuhsu, L. I. N., Chang, W., & Lihua, C. H. E. N. (2013). How do thinking styles influence collaborative dispositions? A study on the relationships between thinking styles and collaborative dispositions for youngsters in Taiwan. *Educational Sciences: Theory & Practice*, 13(4).

- Olpak, Y. Z., & Korucu, A. T. (2014). Öğrencilerin ders çalışma yaklaşımlarının farklı değişkenler açısından incelenmesi. *Ahi Evran Üniversitesi Kırşehir Eğitim Fakültesi Dergisi*, 15(1), 333-347.
- Ozan, C., & Çiftçi, M. (2013). Eğitim fakültesi öğrencilerinin öğrenme yaklaşımları tercihleri ve öğrenmeye ilişkin algılarının incelenmesi. *Pegem Eğitim ve Öğretim Dergisi*, 3(1), 55-66.
- Ozan, C., Köse, E., & Gündoğdu, K. (2012). Okul öncesi ve sınıf öğretmenliği öğrencilerinin öğrenme yaklaşımlarının incelenmesi. *Eğitim Bilimleri Araştırmaları Dergisi*, 2(2), 75-92.
- Özgür, H., & Tosun, N. (2012). Öğretmen adaylarının derin ve yüzeysel öğrenme yaklaşımlarının çeşitli değişkenler açısından incelenmesi. *Mehmet Akif Ersoy Üniversitesi Eğitim Fakültesi Dergisi*, 1(24), 113-125.
- Prosser, M., & Trigwell, K. (1999). Relational perspectives on higher education teaching and learning in the sciences. *Studies in Science Education*, 33(1), 31-60.
- Senemoğlu, N. (2011). Eğitim fakültesi öğrencilerinin öğrenme yaklaşımları ve çalışma becerileri. *Eğitim ve Bilim*, 36(160), 65-80.
- Sezgin Selçuk, G., Çalışkan, S., & Erol, M. (2007). Fizik öğretmen adaylarının öğrenme yaklaşımlarının değerlendirilmesi. *Gazi Eğitim Fakültesi Dergisi*, 27(2), 25-41.
- Sternberg, R. J. (1994). Allowing for thinking. *Educational Leadership*, 52(3), 36-40.
- Sünbül, A. M. (2004). Düşünme stilleri ölçeğinin geçerlik ve güvenilirliği. *Eğitim ve Bilim Dergisi*, 29(132), 25-42.
- Şahin Taşkın, Ç. (2012). Epistemolojik inançlar: Öğretmen adaylarının öğrenme yaklaşımlarını yordayıcı bir değişken. *Mustafa Kemal Üniversitesi Sosyal Bilimler Enstitüsü Dergisi*, 9(19), 273-285.
- Tortop, H. S., Çalışkan, G., & Dinçer, M. (2013). Öğretmen adaylarının kişilikleri ile düşünme stilleri arasındaki ilişkinin belirlenmesi. *Mustafa Kemal Üniversitesi Sosyal Bilimler Enstitüsü Dergisi*, 9(19).
- Yılmaz, M. B., & Orhan, F. (2011). Ders çalışma yaklaşımı ölçeğinin Türkçe formunun geçerlik ve güvenilirlik çalışması. *Eğitim ve Bilim*, 36(159).

EXPLORING PRESERVICE EARLY CHILDHOOD TEACHERS' MATHEMATICS-RELATED EMOTIONS

Deniz MEHMETLİOĞLU
Ağrı İbrahim Çeçen University
medeniz@metu.edu.tr

Çiğdem HASER
Middle East Technical University
chaser@metu.edu.tr

ABSTRACT: Drawings have been used to understand meanings preservice teachers attached to mathematics (Burton, 2012). In this study we focused on the preservice early childhood teachers' views regarding mathematics. Forty-seven preservice early childhood teachers were asked to draw a picture to respond the question "What is Math?" at the beginning and at the end of the "Teaching Mathematics in Early Childhood" course focusing on mathematics concepts and teaching methods for preschool classrooms. Participants were also asked to explain their drawings with some descriptive sentences. Both drawings and written statements were analyzed through open coding with focus on emotions. Comparison of pre- and post-drawings indicated that participants had negative emotions towards mathematics at the beginning of the class while these negative emotions were replaced with positive emotions at the end of the course. Our findings suggest that preservice teachers might bring negative emotions related to mathematics. However, mathematics teaching courses have the potential for developing positive mathematics-related emotions.

Key words: preservice early childhood teachers, mathematics-related emotions, teacher education

COMPLETENESS IN DISLOCATED QUASI-METRIC SPACE

Elida HOXHA

Department of Mathematics, Faculty of Natural Science University of Tirana
Tirana, Albania

hoxhaelida@yahoo.com

Siditë DURAJ

Department of Mathematics and Computer Science
Faculty of Natural Science
University of Shkoder

Shkoder, Albania

siditaduraj@yahoo.com

ABSTRACT: In this paper we will discuss completeness of dislocated quasi metric space not in the terms of Cauchy sequences but in the terms of existence of fixed point for ψ - φ weakly contractive mappings. This result generalizes the result of Z.Liu in [5]

Key words: completeness, dislocated quasi-metric space, $\varphi - \psi$ weakly contractive mappings.

INTRODUCTION

The concept of dislocated metrics was studied under the name of metric domains in the context of domain theory in [2]. As a generalization of metrics where the self distance for any point need not to be equal to zero, Hitzler and Seda, introduced the notion of dislocated metric spaces [7] and generalized the celebrated Banach Contraction Principle in such spaces. These metrics play a very important role not only in topology but also in other branches of science involving mathematics especially in logic programming and electronic engineering. Zeyada[9] initiated the concept of dislocated quasi-metric space and generalized the result of Hitzler and Seda[1] in dislocated quasi-metric spaces.

Characterizations of metric completeness have received much attention in recent years. Hu [4] show that a metric space is complete if and only if any Banach contraction on closed subset thereof has a fixed point. Taskovic [8] also obtained a result similar to Hu using the notion of diametral ψ -contraction. Zhang [10] proved that a metric space is complete if and only if each Kannan type contraction on it has a fixed point. Z. Liu [5] extend the result of Zhang and Park and Kang replacing Kannan type contraction with more general conditions and give characterizations of the metric completeness using single valued and multivalued mappings.

The purpose of the present paper is to contribute in this field. We have considered a family of generalized ψ - φ weakly contractive mappings and will discuss completeness of dislocated quasi metric space not in the terms of Cauchy sequences but in the terms of existence of fixed point for ψ - φ weakly contractive mappings.

PRELIMINARIES

Definition 1.1. Let X be a non-empty set and d is a nonnegative real-valued function on $X \times X$ such for all $x, y, z \in X$:

- 1) $d_1: d(x, x) = 0$
- 2) $d_2: d(x, y) = d(y, x) = 0 \Rightarrow x = y$
- 3) $d_3: d(x, y) = d(y, x)$
- 4) $d_4: d(x, y) \leq d(x, z) + d(x, z)$

If d satisfies the conditions $d_1 - d_4$ then d is called a metric on X . If d satisfies the conditions $d_2 - d_4$ then d is called a dislocated metric if d satisfies only d_2 and d_4 then d is called a dislocated quasi-metric on X [6]. A nonempty set with a dislocated quasi-metric d , i. e., (X, d) is called a dislocated quasi-metric space.

Definition 1.2. [6] A sequence (x_n) in a dislocated quasi-metric space (X, d) is called a right Cauchy sequence if $\forall \varepsilon > 0, \exists n_0 \in \mathbb{N}, \forall m, n \in \mathbb{N}$ such that $n_0 < n < m$ we will have $d(x_m, x_n) < \varepsilon$.

Definition 1.3. [6] A sequence (x_n) in a dislocated quasi-metric space (X, d) is called a left Cauchy sequence if $\forall \varepsilon > 0, \exists n_0 \in \mathbb{N}, \forall m, n \in \mathbb{N}$ such that $n_0 < n < m$ we will have $d(x_n, x_m) < \varepsilon$.

Definition 1.4. [6] A sequence (x_n) in a dislocated quasi-metric space (X, d) is called a Cauchy sequence if $\forall \varepsilon > 0, \exists n_0 \in \mathbb{N}, \forall m, n \in \mathbb{N}$ such that $n_0 < n, m$ we will have $d(x_n, x_m) < \varepsilon$ or $d(x_m, x_n) < \varepsilon$.

Definition 1.5. The sequence (x_n) is said to be “bi”-Cauchy if $\forall \varepsilon > 0, \exists n_0 \in \mathbb{N}$ such that $\forall n, m > 0$ we have $\max\{d(x_n, x_m), d(x_m, x_n)\} < \varepsilon$.

Definition 1.6. [6] A sequence (x_n) in a dislocated quasi-metric space (X, d) converges with respect to dislocated quasi-metric d if there exists $x \in X$, such that $\lim_{n \rightarrow \infty} d(x, x_n) = \lim_{n \rightarrow \infty} d(x_n, x) = 0$.

In this case x is called dq-limit of (x_n) and we write $x_n \rightarrow x$.

Definition 1.7. [6] A dislocated quasi-metric space (X, d) is called complete if every Cauchy sequence is convergent with respect to dislocated quasi-metric d .

Definition 1.8. The dislocated quasi-metric space (X, d) is said to be “bi”-complete if for every “bi”-Cauchy sequence (x_n) in it, is convergent.

Let T be a self mapping on itself in a dislocated quasi-metric space (X, d) . For $x, y \in X$ and $A \subset X$ define $O(x, T) = \{T^n x : n \in \mathbb{N}_0\}$ and $O(x, y, T) = O(x, T) \cup O(y, T)$ and

$Diam A = \delta = \sup \{d(x, y), \text{ for all } x, y \in A\}$.

Z.Liu in [5] has proved the following theorem:

Theorem 1.9. For a metric space (X, d) the following statements are equivalent:

1) (X, d) is complete;
 2) If f is a self-mapping of X satisfying for every x, y in X and some ψ, φ
 $d(fx, fy) \leq \psi(\delta(O(x, y, f))) - \varphi(\delta(O(x, y, f)))$, where $\psi, \varphi : [0, +\infty[\rightarrow [0, +\infty[$, ψ is non-decreasing and continuous on the right, $\psi(t) < t$, for all $t > 0$ then f has a fixed point;

3) If f is a self-mapping of X satisfying the condition $d(fx, fy) \leq r(\delta(O(x, y, f)))$ $0 \leq r < 1$, then f has a fixed point.

In this paper we extend the results of Z. Liu [5] replacing the condition (1) in theorem 1.9 with more general conditions and give characterizations of completeness of dq-metric spaces

MAIN RESULTS

Theorem 2.1 For a dislocated quasi-metric space (X, d) the following statements are equivalent

1) (X, d) is complete;
 2) If T is a self mapping of X satisfying for every x, y in X ,
 $\psi(d(Tx, Ty)) \leq \psi(\delta(O(x) \cup O(y))) - \varphi(\delta(O(x) \cup O(y)))$

Where $\psi, \varphi : [0, +\infty[\rightarrow [0, +\infty[$, ψ is non-decreasing and continuous, φ is lower semi continuous function, $\psi(t) < t$, $\psi(t) > 0$, $\varphi(t) > 0$ for all $t > 0$ and $\psi(0) = \varphi(0) = 0$,

then T has a fixed point;

3) If T is a self-mapping of X satisfying the condition $d(Tx, Ty) \leq r(\delta(O(x) \cup O(y)))$, $\delta(O(x) \cup O(y)) < \infty$, $0 \leq r < 1$, then T has a fixed point.

Proof: Let proof that 1) \Rightarrow 2).

For x, y in X and $n \in \mathbb{N}$, let $x_n = T^n x$, $y_n = T^n y$. From (2), for $k, m \geq n$ in \mathbb{N} we have

$$\psi(d(Tx_k, Ty_m)) \leq \psi(\delta(O(x_k) \cup O(y_m))) - \varphi(\delta(O(x_k) \cup O(y_m)))$$

$$\psi(d(Tx_{n+1}, Ty_{n+1})) \leq \psi(\delta(O(x_{n+1}) \cup O(y_{n+1}))) - \varphi(\delta(O(x_{n+1}) \cup O(y_{n+1}))) \leq \psi(\delta(O(x_{n+1}) \cup O(y_{n+1}))). \quad (4)$$

Hence as ψ is monotonically non-decreasing we have

$$d(Tx_{n+1}, Ty_{n+1}) \leq \delta(O(x_{n+1}) \cup O(y_{n+1})) = \delta(O(T^n x) \cup O(T^n y))$$

$\{\delta(O(T^n x) \cup O(T^n y))\}_{n \in \mathbb{N}}$ is not increasing and bounded below, $\delta(O(T^n x) \cup O(T^n y)) \geq 0$, so there exists $\gamma \geq 0$ such that, $\delta(O(T^n x) \cup O(T^n y)) \rightarrow \gamma$ and

$$d(Tx_{n+1}, Ty_{n+1}) \leq \gamma \leq \delta(O(T^{n+1}x) \cup O(T^{n+1}y))$$

Since ψ is continuous and φ is lower semi-continuous, we have

$$\lim_{n \rightarrow \infty} \psi(\delta(O(T^n x) \cup O(T^n y))) = \psi(\gamma) \quad \varphi(\gamma) \leq \liminf_{n \rightarrow \infty} \varphi(\delta(O(T^n x) \cup O(T^n y))) .$$

By (4) and the property of the function ψ and φ we conclude that

$\psi(\gamma) \leq \psi(\gamma) - \varphi(\gamma)$ from where $\varphi(\gamma) \leq 0$ which is a contradiction. That's why

$$\varphi(\gamma) = 0 \Rightarrow \gamma = 0 \text{ and } \lim_{n \rightarrow \infty} \delta(O(T^n x) \cup O(T^n y)) = 0. \quad (5)$$

By the definition of δ and (5) we have

$$\begin{aligned} \lim_{\substack{n \rightarrow \infty \\ m \rightarrow \infty}} d(x_m, x_n) &= \lim_{\substack{n \rightarrow \infty \\ m \rightarrow \infty}} d(x_n, x_m) = 0; \\ \lim_{\substack{n \rightarrow \infty \\ m \rightarrow \infty}} d(y_n, y_m) &= \lim_{\substack{n \rightarrow \infty \\ m \rightarrow \infty}} d(y_m, y_n) = 0, \\ \lim_{\substack{n \rightarrow \infty \\ m \rightarrow \infty}} d(x_n, y_m) &= \lim_{\substack{n \rightarrow \infty \\ m \rightarrow \infty}} d(y_m, x_n) = 0, \end{aligned} \quad (6)$$

and so (x_n) and (y_n) are "bi"- Cauchy sequences.

By completeness of (X, d) there is a point $u \in X$ such that $(x_n) \rightarrow u$.

By the triangle inequality of quasi dislocated metric d and (6) we have

$$d(y_n, u) \leq d(y_n, x_n) + d(x_n, u), \text{ so } \lim_{n \rightarrow \infty} d(y_n, u) = 0$$

$$d(u, y_n) \leq d(u, x_n) + d(x_n, y_n), \text{ so } \lim_{n \rightarrow \infty} d(u, y_n) = 0$$

Hence, the sequence (y_n) converges in u .

Now we will proof that u is a fixed point for T which is equivalent with $\delta(O(u)) \rightarrow 0$.

Suppose that $\delta(O(u)) > 0$. For $n, m \in \mathbb{N}$ by (2) and knowing that Ψ is non-decreasing,

$$\begin{aligned} \Psi(d(T^n u, T^m u)) &\leq \psi(\delta(O(T^{n-1}u)) \cup O(T^{m-1}u)) - \varphi(\delta(O(T^{n-1}u)) \cup O(T^{m-1}u)) \leq \\ &\leq \Psi(\delta(O(T^{n-1}u)) \cup O(T^{m-1}u)) \leq \psi(\delta(u)) \end{aligned}$$

Then $d(T^n u, T^m u) \leq \delta(O(u))$ for all $n, m \in \mathbb{N}$.

$$\text{So, } \delta(O(Tu)) \leq \delta(O(u)) = \sup\{d(T^m u, u), d(u, T^m u), m \in \mathbb{N}\},$$

By the $x_n \rightarrow u$ for every $\varepsilon > 0$, exists $k \in \mathbb{N}$ such that $d(x_n, u) < \varepsilon$ and $d(u, x_n) < \varepsilon$ for $n > k$.

For $m \in \mathbb{N}$ and $n > k$, by (2), we have

$$\begin{aligned} d(u, T^m u) &\leq d(u, T^n x) + d(T^n x, T^m u) \leq \\ &\leq \varepsilon + \psi(\delta(O(T^{n-1}x)) \cup O(T^{m-1}u)) - \varphi(\delta(O(T^{n-1}x)) \cup O(T^{m-1}u)) \end{aligned}$$

$$\text{But } \delta(O(T^{n-1}x)) \cup O(T^{m-1}u) = \max\{2\varepsilon, \delta(O(u)) + \varepsilon\}.$$

So, $d(u, T^m u) \leq \varepsilon + \psi(\max\{2\varepsilon, \delta(O(u)) + \varepsilon\}) - \varphi(\max\{2\varepsilon, \delta(O(u)) + \varepsilon\})$ for all $m \in \mathbb{N}$ and

$$\sup\{d(u, T^m u) : m \in \mathbb{N}\} \leq \varepsilon + \psi(\max\{2\varepsilon, \delta(O(u)) + \varepsilon\}) - \varphi(\max\{2\varepsilon, \delta(O(u)) + \varepsilon\}).$$

Hence,

$$\delta(O(u)) = \sup\{d(u, T^m u) : m \in \mathbb{N}\} \leq \psi(\delta(O(u)) - \varphi(\delta(O(u))) \leq \psi(\delta(O(u)) < \delta(O(u)),$$

which is impossible. Hence $\delta(O(u)) = 0$ and $d(u, Tu) = 0$ and $d(Tu, u) = 0$, so u is a fixed point of T , $Tu = u$.

Now let's proof that 2) \Rightarrow 3).

Let's take $\psi(t) = rt$ for all t in $[0, +\infty)$ and $0 \leq r < 1$ and $\varphi(t) = (1 - r)t$ and form the condition (2) we have

$$d(Tx, Ty) \leq \delta(O(x) \cup O(y)) - (1 - r)\delta(O(x) \cup O(y)) = r\delta(O(x) \cup O(y))$$

and condition 3) is satisfied so far. Hence T has a fixed point

3) \Rightarrow 1). It is true from the theorem 2.1.

This result is more generalized than result of theorem 2.1 of Z.Liu in [5] in two directions. We have replaced the metric spaces with quasi-dislocated spaces and contractive condition (2) in theorem 2.1 of Z.Liu with more general conditions (2) in our theorem.

REFERENCES

- [1] Aage, T. and Seda, J.N. (2000). *Some Result of Fixed Point Theorem in Dislocated Quasi-Metric Spaces*, Bulletin of Marathwada Mathematical Society, 9,1-5.
- [2] Abramsky, S. and Jung, , (2000) A. *Domain Theory in Handbook of Logic in Computer Science*, volume 3. New York: Oxford Univ.
- [3] Hitzler P. and Seda, A. K., *Dislocated Topologies*, J. Electr.Engin. 51(12/3); 3 ;7.
- [4] Hu, T.K. (1967). *On a Fixed Point Theorem for Metric Spaces*. Amer. Math Monthly 74, 436-437.
- [5] Liu, Z. *Fixed Point and Completeness*, Tr. J of Mathematics 20 (1996), 467-472.
- [6] Muraliraj, A. Jahir Husain, R. *Generalized Fixed Point Theorems in Dislocated Quasi-Metric Spaces*, ISSN:2050-7461.
- [7] Hitzler, P. (1994). *Generalized Metrics and Topology in Logic Programming Semantics*. Ph. d. thesis, National University of Ireland, Press. University College Cork.
- [8] Taskovic, M.R. (2001). *A Characterization of Complete Metric Spaces*. Math. Japonica 29, 107-113.
- [9] Zeyada, F.M. Hassan, F. M, G. H, and Ahmed, M.A. (2005). *A Generalization of a Fixed Point Theorem Due to Hitzler and Seda in Dislocated Quasi-Metric Spaces*. The Arabian J for Sci. and Eng., 31(1A):111:114,
- [10] Zhang, C. *The Generalized Set-Valued Contraction and Completeness of Metric Space*. Math. Japonica 35, 111-118 91990).

ORTAOKUL ÖĞRENCİLERİNİN ÇEVRESEL TUTUM, DAVRANIŞ VE DÜŞÜNCELERİNİN DOĞA EĞİTİMİ PROJESİNE BAĞLI DEĞİŞİMİ¹

THE CHANGE OF SECONDARY SCHOOL STUDENTS ENVIRONMENTAL ATTITUDE, BEHAVIOR AND THOUGHTS WITH NATURE TRAINING PROJECT

Özden TEZEL
Eskişehir Osmangazi Üniversitesi
Ozden.tezel@gmail.com

Ersin KARADEMİR
Eskişehir Osmangazi Üniversitesi
eekarademir@gmail.com

ÖZET: Bu çalışma, TÜBİTAK tarafından desteklenen doğa eğitimi projesi çerçevesinde gerçekleştirilmiştir. Bu çalışmada, “Fenin Araştırmacı Doğasını Anlıyorum” projesinin, çevreye yönelik tutum, davranış ve düşünce üzerindeki etkililiğini; öğrencilerin fen ve doğa hakkındaki görüşlerini; uygulama öncesinde öğrencilerin projeden beklentileri ve sonrasında da projenin kendilerine olan katkılarını belirlemek amaçlanmıştır. Çalışma grubunu, 12 Ağustos-08 Eylül 2013 tarihleri arasında gerçekleştirilen doğa eğitimi programına katılan 108 ortaokul öğrencisi oluşturmaktadır. Her gruba, uygulamanın başlangıcında ön-test ve bitiminde son-test ölçek uygulaması gerçekleştirilmiş ve açık uçlu sorulardan oluşan bir ölçek aracı da kullanılmıştır. Ölçeklerden elde edilen bulgulara göre; gruplarda ön-test ve son-test uygulamalarında istatistiksel olarak anlamlı bir farklılık saptanmamakla birlikte, gruplar arasında yapılan tek yönlü varyans analizine göre; 5. ve 6. sınıfı bitirmiş öğrencilerin çevresel tutumlarının, diğer gruplara göre daha yüksek olduğu saptanmıştır. Öğrencilerin görüşlerinden elde edilen bulgulara göre; öğrencilerin fen ve doğaya ilişkin görüşlerinin, proje çalışmaları esnasında gerçekleştirdikleri uygulamalı etkinliklerle ve doğada yaşamı tecrübe etmeleriyle, olumlu yönde değiştiği söylenebilir.

Anahtar sözcükler: araştırmacı fen eğitimi, fenin araştırmacı doğası, çevre bilinci

ABSTRACT: The purpose of this study is to investigate the effects of the project “I Understand the Researching Nature of Science” supported by The Scientific and Technological Research Council of Turkey (TUBITAK) on environmental attitudes, behavior and thought; the opinions of the students about science and nature; expectations of the students before the project and contributions of the project at the end of the Project. The study group consists of 108 secondary school students who participated in this nature education project carried out on 12 August-08 September 2013. For each group, a pretest-scale application was made at the beginning of the application and post test-scale application was made at the end of the application. Based on the findings obtained from the opinions of the students about science; it can be stated that opinions of the students about science have changed favorably by applied activities made during the project studies and by experiencing life in the nature.

Key words: researching science education, nature of researching science education, environmental consciousness

GİRİŞ

“Okul dışı öğrenme” yurtdışı alan yazınında “outdoor education” olarak yer almaktadır. Okul dışı öğrenme (outdoor education); çevre eğitimi (environmental education), okul dışı etkinlik (outdoor activities) ve kişisel ve sosyal gelişiminin (personal & social developmant) birleşiminden meydana gelir (Higgins, Loynes and Crowther, 1997). Benedict (1991) aktif öğrenmenin, çevre eğitiminin duygusal, etik ve davranışsal hedeflerini başarmanın anahtarı olduğunu ifade etmiştir. Yurtdışında yapılan bazı çalışmalarda, birçok dersin okul dışı ortamlarda yapıldığı belirtilmektedir (Barker, Slingsby & Tilling, 2002; Farmer, Knapp, & Benton, 2007; Lugg & Slattery, 2003; Braund, and Reiss, 2006). İlgili çalışmalarda fen eğitiminin, biyoloji eğitiminin okulun dışında da yapılabilirdiği hususuna vurgu yapılmaktadır. Ülkemizde ise, son yıllarda artan doğa eğitimleri, çevre

¹ Bu çalışma, TÜBİTAK tarafından desteklenen 113B114 kodlu, Fenin Araştırmacı Doğasını Anlıyorum isimli Proje kapsamında gerçekleştirilmiştir.

eğitimleri ve okul dışı etkinlikler; konuya olan ilginin arttığını göstermektedir (Güler, 2009; Atasoy, 2006; Erten, 2004, Uzun, Uzun ve Keleş, 2010; Bozdoğan, 2007; Balkan Kıyıcı ve Atabek Yiğit, 2010).

TÜBİTAK tarafından desteklenen “Fenin Araştırmacı Doğasını Anlıyorum” isimli doğa eğitimi projesi çerçevesinde gerçekleştirilen bu çalışmada, ortaokul öğrencilerinin çevreye yönelik tutum, davranış ve düşüncelerinin doğa eğitimi projesine bağlı değişimini; öğrencilerin fen ve doğa hakkındaki görüşlerini; uygulama öncesinde öğrencilerin projeden beklentilerini ve sonrasında da projenin kendilerine olan katkılarını belirlemek amaçlanmıştır.

YÖNTEM

Çalışmanın Modeli

Bu çalışma öntest-sontest desenine dayalı olarak gerçekleştirilmiştir.

Çalışma Grubu

Çalışma grubunu, TÜBİTAK tarafından desteklenen, 12 Ağustos-08 Eylül 2013 tarihleri arasında gerçekleştirilen “Fenin Araştırmacı Doğasını Anlıyorum” isimli doğa eğitimi programına katılan 108 ortaokul öğrencisi oluşturmuştur. Proje etkinliklerine; birinci hafta 5. sınıfı bitiren 27 öğrenci; ikinci hafta 6. sınıfı bitiren 28 öğrenci; üçüncü hafta 7. sınıfı bitiren 25 öğrenci ve dördüncü hafta 8. sınıfı bitiren 28 öğrenci katılmıştır. Katılımcıların 59’u (%55) kız ve 49’u (%45) erkektir. Öğrenci katılımının bedelsiz gerçekleştirilmesi amaçlandığından; çalışma grubunun belli maddi ve sosyal imkânlardan yoksun, akademik başarıları yüksek olan öğrencilerden seçilerek belirlenmesi önem arz etmiştir. Bu sebeple; dört ayrı grubun aynı tür etkinlikleri gerçekleştirdiği bu çalışmada, Sosyal Hizmetler Çocuk Esirgeme Kurumu’nda kalan ortaokul öğrencileri ve sosyo-ekonomik düzeyi düşük olan ailelerin Eskişehir ilinde ortaokul öğrenimi gören çocukları ile çalışma yürütülmüştür.

Doğa Eğitimi Kapsamında Gerçekleştirilen Etkinlikler

Bu çalışmanın toplam uygulama süresi dört haftadır. Bir haftanın 6 tam günü boyunca atölye ve etkinlikler düzenlenmiştir. Yapılan etkinliklerde, hem en üst düzeyde verim sağlamak, hem de geniş bir kitleye ulaşmak hedeflenmiştir. Bütün etkinlikler, ortaokul düzeyinde öğrenim görmekte olan öğrencilere uygun hazırlanmıştır. Farklı bilimsel konu ve alanlarda gerçekleştirilen gözlem, uygulama ve etkinliklerle, disiplinlerarası yapılan bu çalışmanın; öğrencilere, bilime olumlu bir bakış açısı kazandıracağı düşünülmüştür. Aktif öğrenme yöntemlerinin uygulandığı bu proje ile; doğa kamp ve gezisi, fen etkinlikleri, çevre bilinci kazanımı etkinlikleri, bilim turu, sağlık etkinlikleri gibi, fen bilimlerini temel alan etkinliklerin yanı sıra, sanatsal etkinlikler yoluyla da; öğrencilerin öğrenme becerilerini geliştirmeleri hedeflenmiştir.

Veri Toplama Araçları

Bu çalışmada ortaokul öğrencilerinden oluşan her gruba, doğa eğitimi sonucunda çevre bilinçlerindeki değişimi ölçmek amacıyla, uygulamanın başlangıcında ön-test ve bitiminde son-test ölçek uygulaması gerçekleştirilmiştir.

Tablo 1. Ölçeklere ait croanbach alfa güvenilirlik katsayıları

	Ön test	Son test
Çevresel davranış ölçeği	0,880	0,919
Çevresel düşünce ölçeği	0,751	0,693
Çevresel tutum ölçeği	0,798	0,832

Üç kısımdan oluşan ölçeğin; birinci kısmı “çevresel davranış alt ölçeği [13 madde]”, ikinci kısmı “çevresel düşünce alt ölçeği [14 madde]” ve üçüncü kısmı ise “çevresel tutum ölçeği [24 madde]” olarak hazırlanmıştır. Çevresel tutum ölçeği; Aslan, Sağır ve Cansaran (2008) tarafından Türkçeye uyarlanmıştır. Ölçek, toplam 24 madde bulunan beşli likert tipindedir. Uzun ve Sağlam (2006) tarafından geliştirilen; 13 maddeden oluşan çevresel davranış alt ölçeği ile 14 maddeden oluşan çevresel düşünce alt ölçeği toplam 27 maddenin bulunduğu beşli likert tipindedir. Ölçeklerin güvenilirlik katsayıları tablo 1’de verilmiştir.

Verilerin Analizi

Elde edilen verilerin istatistiksel analizinde SPSS 15.0 programı kullanılmıştır. Ölçekten elde edilen toplam puanlar üzerinden, ön-test ve son-test karşılaştırılmasına gidilmiştir. Gruplar arası (5., 6., 7. ve 8. sınıflar) farklılıkların belirlenmesi için tek yönlü varyans analizi yapılmıştır. Ayrıca, etkinliklerin başlangıcında ve bitiminde açık uçlu sorulardan oluşan bir ölçme aracı da kullanılmıştır. Bu ölçme aracında, öğrencilerin fen ve doğa hakkındaki görüşleri elde edilmeye çalışılmıştır. Ayrıca, proje öncesinde öğrencilerin projeden beklentileri ve sonrasında da projenin kendilerine olan katkıları öğrenci görüşlerine göre değerlendirilmiştir.

BULGULAR

Bu bölümde, öntest-sontest desenine dayalı uygulanan, çevresel tutum ve çevresel düşünce ile çevresel davranış alt ölçeklerinden alınan toplam puanlar üzerinden; ön-test ve son-test karşılaştırılmasına gidilmiştir. Gruplar arası (5, 6, 7 ve 8. sınıflar) farklılıkların belirlenmesi için tek yönlü varyans analizi yapılmıştır. Ayrıca, öğrencilerin fene ilişkin görüşleri; etkinlikler öncesinde projeden beklentileri ve etkinlikler sonrasında projenin kendilerine olan katkıları, öğrenci görüşlerine göre değerlendirilmiştir. Bütün katılımcılar için elde edilen sonuçlar, aşağıda sunulmuştur.

Ölçeklerden elde edilen sonuçlar

Çevreye yönelik tutum, davranış ve düşünce ölçeklerinin, gruplara ön-test ve son-test uygulamalarından elde edilen verilere göre, istatistiksel olarak anlamlı bir farklılık saptanmamıştır. Gruplar arasında yapılan tek yönlü varyans analizine göre; 5. ve 6. sınıfı bitirmiş öğrencilerin çevresel tutumlarının, diğer gruplara göre daha yüksek olduğu saptanmıştır. Ayrıca, kız öğrencilerin tutumları ile erkek öğrencilerin tutumları arasında, herhangi anlamlı bir farklılık saptanmamıştır.

Öğrencilerin fene ilişkin görüşlerinden elde edilen sonuçlar

Etkinlikler öncesinde “fen deyince ne anlıyorsunuz?” sorusuna, çoğunlukla “fizik, kimya ve biyoloji anlıyorum” gibi cevaplar veren öğrenciler; etkinlikler sonrasında, “fenin daha ziyade doğa ile ilişkili olduğunu ve gerçek yaşamda gözlemediğimiz pek çok şeyin aslında fen olduğunu, doğadaki biyolojik çeşitlilik, tabiattaki doğa olayları ve benzeri pek çok durum ve çözüm yolunun fenden geçtiğini anlıyorum” gibi cevaplar vermişlerdir.

Öğrencilerin proje uygulamalarından beklentileri ve projenin öğrencilere kazandırdıkları

Öğrencilerin etkinlikler öncesinde proje uygulamalarından beklentileri ve etkinlikler sonrasında projenin kendilerine olan katkıları, öğrenci görüşlerine göre değerlendirilmiştir. Öğrencilerin büyük bir kısmı, projeden eğlenceli bir süreç ile birlikte yeni bilgiler edinmeyi beklerken, bazıları ise, projeden önümüzdeki yıllarda okul derslerinde faydalı bilgilerin sunulmasını beklemişlerdir. Ayrıca okulda öğrendikleri bilgileri pekiştirmeyi de ümit etmişlerdir. Öğrenciler, proje uygulamaları sonrasında etkinliklerin kendilerine olan katkılarını genel anlamda aşağıdaki sözcüklerle ifade etmişlerdir: Çevre bilinci ve duyarlılığının oluşması; Fen kavramlarının şarkı ve şiirlerle öğrenilmesi; Enerjinin dönüşümü, enerji kaynakları, yenilenebilir ve sürdürülebilir enerjinin kavranması; Doğada yaşamı, yemek yapmayı ve günlük plân program yapmayı öğrenme; Doğada yaşamının zorluklarıyla başa çıkma yollarını öğrenme; Yaşamın her anında karşılaştıkları durum ve olayların fen ile olan ilişkisini fark etme; Geri dönüşümün sağladığı faydalar; Bağımsız fikir üretme ve deney yapma becerisinin gelişmesi; Okuldaki derslerde fayda sağlayacak bilgiler öğrenme; Fenin zevkli ve bilimsel bir ders olduğunun farkına varma; Bazı bitki ve hayvanları tanıma, doğa yürüyüşünde bunları fark etme ve inceleme; Zehirli hayvanlara karşı önlem almayı öğrenme; Pusula ve harita ile yön bulmayı öğrenme; Birlikte yaşamayı ve toplu hareket edebilmeyi öğrenme; İlk yardım yapmayı öğrenme; Dengeli beslenme ve doğru el yıkamayı öğrenme; Fenin birçok ders ve olayla bağlantılı olduğunu öğrenme, Yaşadığımız ilin tarihini ve kültürünü öğrenme; Fen konularını şarkılarla öğrenme.

SONUÇ ve ÖNERİLER

TÜBİTAK tarafından desteklenen “Fenin Araştırmacı Doğasını Anlıyorum” başlıklı proje çerçevesinde, çalışmada elde edilen sonuçlar, aşağıda özetlenmiştir:

Çevreye yönelik tutum, davranış ve düşünce ölçeklerinden elde edilen bulgulara göre; çalışma gruplarına ön-test ve son-test uygulamalarında istatistiksel olarak anlamlı bir farklılık saptanmamıştır. Bu durumda, projenin başlangıç ve bitiş tarihinin birbirine yakın olması etken olabilir. Gruplar arasında yapılan tek yönlü varyans analizine göre; 5. ve 6. sınıfı bitirmiş öğrencilerin çevresel tutumlarının, diğer gruplara göre daha yüksek olduğu belirlenmiştir. Elde edilen bu bulguya göre, öğrencilerin yaş gurubu büyüdükçe; çevreye, fen ve doğaya olan ilgilerinin nispeten azalabildiği sonucu çıkarılabilir. Çalışma bulgularına göre, kız öğrencilerin tutumları ile erkek öğrencilerin tutumları arasında, anlamlı bir farklılık saptanmamıştır. Elde edilen bulgulara göre, 6 günlük etkinliklerin gerçekleştiği proje uygulamaları programında, öğrencilerin etkinlikler öncesi ve etkinlikler sonrasında, çevreye yönelik tutumlarında anlamlı farklılık olmamasına rağmen, aşağıda sunulan bulgular değerlendirildiğinde; öğrencilerin proje çalışmalarından, daha güçlü olumlu tutumlarla ayrıldıkları söylenebilir.

Mittelstaedt, Sanker ve Vanderveer'in (1999), 5 günlük biyolojik çeşitlilikle ilgili etkinliklerin gerçekleştiği yaz okulu programında, öğrencilerin çevreye yönelik olumlu tutumlara sahip olmalarına rağmen, yaz okulundan daha güçlü olumlu tutumlarla ayrıldıklarını tespit ettikleri bulgu, bu çalışmada ulaşılan bulguları destekler niteliktedir. Bu araştırmanın sonuçlarını destekler nitelikte bazı çalışmalar bulunmaktadır: Ballantyne ve Packer (2002) araştırmalarında, doğayla etkileşimin etkili bir strateji olduğunu belirtmiştir. Keleş, Uzun, N. ve Uzun, V. (2010) araştırmalarında, doğa eğitimi projesinde gerçekleştirilen aktif öğrenme yöntem ve tekniklerinin kullanıldığı etkinliklerin, öğretmen adaylarının çevreye yönelik tutum ve bilinçlerini geliştirmede etkili olduğunu gözlemlemiştir.

Etkinlikler öncesinde “fen deyince ne anlıyorsunuz?” sorusuna, çoğunlukla “fizik, kimya ve biyoloji anlıyorum” gibi cevaplar veren öğrenciler; etkinlikler sonrasında, “fenin daha ziyade doğa ile ilişkili olduğunu ve gerçek yaşamda gözlemlediğimiz pek çok şeyin aslında fen olduğunu, doğadaki biyolojik çeşitlilik, tabiattaki doğa olayları ve benzeri pek çok durum ve çözüm yolunun fenden geçtiğini anlıyorum” gibi cevaplar vermişlerdir. Buna göre, öğrencilerin fen hakkındaki görüşlerinin, proje çalışmaları esnasında gerçekleştirdikleri uygulamalı etkinliklerle ve doğada yaşamı tecrübe etmeleriyle, olumlu yönde değiştiği söylenebilir. Doğa Eğitimi Projesi çerçevesinde gerçekleştirilen etkinliklerle, klâsik öğrenme metotlarının dışında olan ve daha çok günlük yaşantıdan ve deneyimlerden beslenen bir öğrenme ortamı sunulmuştur. Sözkonusu proje uygulamaları, değişik öğrenme ortamları yoluyla öğrencilerin; basit fen olguları konusunda farkındalık kazanmasına, bilim için gerekli görülen -ve, belki de en önemli duygu olan- merak duygularının artmasına ve araştırma, öğrenme arzularının harekete geçmesine katkıda bulunmuştur. Farklı bilimsel konu ve alanlarda gerçekleştirilen gözlem, uygulama ve etkinliklerle; disiplinlerarası yapılan bu proje uygulamalarının; öğrencilere, bilime olumlu bir bakış açısı kazandırdığını söylemek mümkündür. Elde edilen sonuçlara dayanarak, fen ve teknoloji öğretim programına; günlük hayattaki nesnelere olaylardaki fen kavramlarının, öğrencilerin sosyalleşmelerine ve hayatın içinde öğrenmelerine imkân sağlayacak biçimde, okul dışında da öğretilebileceği türde bir program eklenmesi ve öğretmenlerin öğretim uygulamalarında bu tarz etkinliklere yer vermeleri önerilmektedir.

Öğrencilerin etkinlikler öncesinde proje uygulamalarından beklentileri ve etkinlikler sonrasında projenin kendilerine olan katkıları, öğrenci görüşlerine göre değerlendirilmiştir. Öğrencilerin büyük bir kısmı, projeden eğlenceli bir süreç ile birlikte yeni bilgiler edinmeyi beklerken, bazıları ise, projeden önümüzdeki yıllarda okul derslerinde faydalı bilgilerin sunulmasını beklemişlerdir. Ayrıca okulda öğrendikleri bilgileri pekiştirmeyi de ümit etmişlerdir. Öğrenciler, proje uygulamaları sonrasında etkinliklerin kendilerine olan katkılarını genel anlamda şu sözcüklerle ifade etmişlerdir: Çevre bilinci ve duyarlılığının oluşması; Fen kavramlarının şarkı ve şiirlerle öğrenilmesi; Enerjinin dönüşümü, enerji kaynakları, yenilenebilir ve sürdürülebilir enerjinin kavranması; Doğada yaşamı, yemek yapmayı ve günlük plân program yapmayı öğrenme; Doğada yaşamının zorluklarıyla başa çıkma yollarını öğrenme; Yaşamın her anında karşılaştıkları durum ve olayların fen ile olan ilişkisini fark etme; Geri dönüşümün sağladığı faydalar; Bağımsız fikir üretme ve deney yapma becerisinin gelişmesi; Okuldaki derslerde fayda sağlayacak bilgiler öğrenme; Fenin zevkli ve bilimsel bir ders olduğunun farkına varma; Bazı bitki ve hayvanları tanıma, doğa yürüyüşünde bunları fark etme ve inceleme; Zehirli hayvanlara karşı önlem almayı öğrenme; Pusula ve harita ile yön bulmayı öğrenme; Birlikte yaşamayı ve toplu hareket edebilmeyi öğrenme; İlk yardım yapmayı öğrenme; Dengeli beslenme ve doğru el yıkamayı öğrenme; Fenin birçok ders ve olayla bağlantılı olduğunu öğrenme, Yaşadığımız ilin tarihini ve kültürünü öğrenme; Fen konularını şarkılarla öğrenme. Aktif öğrenme yöntemlerinin uygulandığı bu proje çalışması ile; doğa kamp ve gezisi, fen etkinlikleri, çevre bilinci kazanımı etkinlikleri, bilim turu, sağlık etkinlikleri gibi, fen bilimlerini temel alan etkinliklerin yanı sıra, sanatsal etkinlikler yoluyla da; öğrencilerin öğrenme becerilerini geliştirmelerine katkıda bulunulmuştur. Söz konusu etkinliklerde asıl amaç; öğrencileri izleyici ve dinleyici -yâni, pasif- konumdan çıkarıp, daha çok uygulayıcı, yaparak ve yaşayarak öğrenen bireyler haline getirmektir. Böylece elde edilen bilgi; öğrenci tarafından yapılandırılıp, özümseceği için, kalıcı bilgi haline dönüşecektir. Öğrenci bilgiyi kalıcı biçimde özümsemediği, bilimsel araştırma ve düşünme hususunda daha fazla inisiyatif sahibi olacaktır. Bu durum, öğrencilerin fen okuryazarı bireyler olmasında önemli katkı sağlayacaktır. Fen okuryazarı sosyal birey, fenin temel becerilerine sahip olmanın yanısıra tarihini de bilen, topluma fayda sağlayabilen, sanatsal konulara ilgili ve sağlık okuryazarı birey olarak da toplumda yerini alacaktır. Bu noktadan hareketle, bu çalışma; fen okuryazarlığının temel bileşenlerini ele alarak, farklı disiplinlerle ilişkilerini ortaya koymuştur. Farklı bilimsel konu ve alanlarda gerçekleştirilen gözlem, uygulama ve etkinliklerle; disiplinlerarası yapılan bu çalışmanın, öğrencilere, bilime olumlu bir bakış açısı kazandırdığı düşünülmektedir. Çalışmada elde edilen sonuçlar, literatürde bulunan bazı çalışmaları (Şahin ve Yazgan, 2013; Keleş, Uzun ve Uzun, 2010; Bogner 1998; Adıgüzel, 2006; Eaton, 2000; Palmberg ve Kuru, 2000) destekler biçimde, fen ve teknoloji öğretim programına, sınıf dışı etkinliklerin eklenmesinin gerekliliğini ortaya koymaktadır. Bundan sonra, hayatın içinde fen öğretimini uygulanabilir kılacak yöntemler geliştirilmesi için zemin hazırlayacak projelerin yapılması/tetiklenmesi önerilir. Ayrıca, araştırmacılara; fen öğretiminde öğrencilerin derse daha etkin bir şekilde katılımını sağlayacak yöntemlerin geliştirilmesine yönelik çalışmalara ağırlık vermesi önerilmektedir.

KAYNAKLAR

- Adıgüzel, Ö. (2006). Okul dışında farklı bir öğrenme ortamı olarak çocuk müzeleri. *Bilim, Eğitim Toplum Dergisi*, Bahar Cilt 4, Sayı:14.
- Aslan, O., Sağır, Ş.U., & Cansaran, A. (2008). Çevre Tutum Ölçeği Uyarlanması ve İlköğretim Öğrencilerinin Çevre Tutumlarının Belirlenmesi. *Selçuk Üniversitesi Ahmet Keleşoğlu Eğitim Fakültesi Dergisi*, 25, 283 - 295.
- Atasoy, E. (2006). *Çevre için eğitim çocuk doğa etkileşimi*. Bursa: Ezgi Kitabevi.
- Ballantyne, R. & Packer, J. (2002). Naturebased excursions: school students perceptions of learning in natural environments. *International Research in Geographical and Environmental Education*, 11(3), 218–236.
- Balkan Kıyıcı, F. & Atabek Yiğit, E. (2010). Science education beyond the classroom: a field trip to wind power plant. *International Online Journal of Educational Sciences*, 2(1), 225–243.
- Barker, S., Slingsby, D. & Tilling, S. (2002). *Teaching biology outside the classroom. Is it heading for extinction?* Field Studies Council/British Ecological Society, Shrewsbury.
- Benedict, F. (Ed.). (1991). *Environmental education for our common future: A handbook for teachers in Europe*. Oslo, Norway: Norwegian University Press.
- Bogner, F. X. (1998). The influence of short-term outdoor ecology education on long-term variables of environmental perspective. *Journal of Environmental Education*, 29(4), 17–29.
- Bozdoğan, A.E. (2007). *Bilim ve teknoloji müzelerinin fen eğitimindeki yeri ve önemi*. Yayınlanmamış Doktora Tezi, Ankara: Gazi Üniversitesi.
- Braund, M. and Reiss, M. (2006). Towards a more authentic Science curriculum: The contribution of out of school learning. *International Online Journal of Science Education*, 28(12), 1373–1388.
- Eaton, D. (2000). Cognitive and affective learning in outdoor education. *Dissertation Abstracts International – Section A: Humanities and Social Sciences*, 60, 10-A, 3595.
- Erten, S. (2004). Çevre eğitimi ve çevre bilinci nedir, çevre eğitimi nasıl olmalıdır? *Çevre ve İnsan Dergisi, Çevre ve Orman Bakanlığı Yayın Organı*, Sayı:65–66.
- Farmer, J., Knapp, D. & Benton, M.G. (2007). An elementary school environmental education field trip: long-term effects on ecological and environmental knowledge and attitude development. *The Journal of Environmental Education. Reports & Research*, 38(3), 33–42.
- Güler, T. (2009). Ekoloji temelli bir çevre eğitiminin öğretmenlerin çevre eğitimine karşı görüşlerine etkileri. *Eğitim ve Bilim*, 34, No.151.
- Higgins, P. Loynes, C. and Crowther, N. eds (1997). *A Guide for Outdoor Educators in Scotland*. SNH: Perth.
- Keleş, Ö., Uzun, N. & Uzun, V. F. (2010). Öğretmen adaylarının çevre bilinci, çevresel tutum, düşünce ve davranışlarının doğa eğitimi projesine bağlı değişimi ve kalıcılığının değerlendirilmesi. *Electronic Journal of Social Sciences*, 9(32), 384-401.
- Lugg, A. & Slattery, D. (2003). Use of a national parks for outdoor environmental education: An australian case study. *Journal of Adventure Education and Outdoor Learning*, 3(1), 77–92.
- Mittelstaedt, R., Sanker, L. & Vanderveer, B. (1999). Impact of a weeklong experiential education program on environmental attitude and awareness. *Journal of Experiential Education*, 22(3), 138-148.
- Palmberg, E.I. & Kuru, J. (2000). Outdoor Activities as a Basis for Environmental Responsibility. *The Journal of Environmental Education*, 31(4), 32-6.
- Şahin F. & Sağlamer Yazgan B. (2013). Araştırmaya dayalı sınıf dışı laboratuvar etkinliklerinin öğrencilerin akademik başarısına etkisi. *Sakarya University Journal of Education*, 3(3), 107-122.
- Uzun, N. ve Sağlam, N. (2006). Ortaöğretim Öğrencileri İçin Çevresel Tutum Ölçeği Geliştirme ve Geçerliliği. *Hacettepe Üniversitesi Eğitim Fakültesi Dergisi*, 30, 240-250.
- Uzun, N., Uzun, V. F. & Keleş, Ö. (2010). Ihlara vadisi (Aksaray) ve çevresinde doğa eğitimi projesinin öğretmen adaylarının çevre bilincine etkisi. 9. *Ulusal Fen Bilimleri ve Matematik Eğitimi Kongresi*, 23 – 25 Eylül 2010, İzmir.

FİZİK ÖĞRETMEN ADAYLARININ ÖĞRETMENİN VE ÖĞRENCİNİN ROLÜ AÇISINDAN EĞİTİM SÜRECİNE İLİŞKİN FELSEFİ GÖRÜŞLERİNİN İNCELENMESİ

THE INVESTIGATION OF PHYSICS TEACHER CANDIDATES' EDUCATIONAL PHISOLOPHIES IN TERMS OF TEACHERS AND STUDENTS ROLES IN LEARNING – TEACHING PROCESS

Selin Görmez Ustaalioğlu
Gazi University
selin.gormez@hotmail.com

Şebnem KANDİL İNGEÇ
Gazi University
singec@gazi.edu.tr

ÖZET: Bu araştırmanın genel amacı, fizik öğretmen adaylarının sahip oldukları eğitim felsefesine ilişkin görüşlerini eğitim sürecinde öğretmen ve öğrenci rolü açısından değerlendirmektir. Bu amaca uygun olarak araştırmada tarama modeli kullanılmıştır. Araştırmaya 86 öğretmen fizik öğretmen adayı katılmıştır. Veriler; Daimicilik, Esasicilik, İlerlemecilik, Varoluşçuluk, Dielektrik Materyalizm, Naturalizm ve Yeniden Kurmacılık eğitim felsefesi akımlarına ilişkin toplam 77 ilkeyi içeren bir ölçek ile elde edilmiştir. Verilerin analizinde puanların frekans(f), yüzde (%) ve ortalama (\bar{X}) değerlerinden yararlanılmıştır. Araştırma sonuçlarına göre, öğretmen adaylarının öğretmenin rolü açısından en yüksek katılım gösterdiği boyut varoluşçuluk alt boyutudur. Öğrencinin rolü açısından esasicilik akımına katılım çok düşük düzeydedir. Araştırmada elde edilen bulgular literatüre dayalı olarak tartışılmıştır.

Anahtar sözcükler: eğitim felsefesi, fizik öğretmen adayı, öğretmenin rolü, öğrencinin rolü.

ABSTRACT: The main purpose of this study is to evaluate department of physics teacher candidates' perceptions about their own educational philosophy in terms of teachers and students roles in learning – teaching process. For this purpose, the study was based on the survey model. A total of 86 physics teacher candidates' participate into the study. The data are collected through a scale which has a total of 77 principles of various issues of educational phisolophies; Perennialism, Essentialism, Progressivism, Existentialism, Dielectric Materialism, Naturalism and Reconstructionism. In the analyze process of data were used frequency(f), percent rate (%) and arithmetic meaning (\bar{X}) values of scores. In terms of the teachers roles in learning – teaching process, the physics teacher candidates' display a higher rate of educational belief in sub-dimensions of both Existentialism. The teachers candidates' showed a low agreement rate in essentialist educational philosophy. Findings were discussed based on the literature.

Key words: Education philosophies, physics teacher candidates, teachers roles, students roles.

FİZİK ÖĞRETMEN ADAYLARININ ÖĞRENME STİLLERİNİN ÇEŞİTLİ DEĞİŞKENLER AÇISINDAN İNCELENMESİ

THE INVESTIGATION OF PHYSICS TEACHER CANDIDATES' LEARNING STYLES IN TERMS OF VARIOUS VARIABLES

Şebnem KANDİL İNGEÇ
Gazi University
singec@gazi.edu.tr

Ali Can KARADENİZ
Gazi University
alicankardeniz@gmail.com

Serap AĞA
Gazi University
serapaga1991@hotmail.com

Tuğçe COŞKUN
Gazi University
tugce_fb_06@hotmail.com

Mina ŞAHİNGÖZ
Gazi University
minasahingoz1991@hotmail.com

Leyla SONDUK
Gazi University
leylasonduk@gmail.com

ÖZET: Araştırmanın amacı, Eğitim Fakültesi OFMAE Bölümü Fizik Öğretmenliği programında öğrenim gören Fizik öğretmen adaylarının, Kolb Öğrenme stilleri içerisinde tercih ettikleri baskın öğrenme stillerini belirlemek; motivasyon türü, cinsiyet, akademik başarı, bilgi iletişim becerileri gibi demografik değişkenler açısından incelemektir. Bu çalışmada genel tarama modellerinden tekil ve ilişkisel tarama modelleri kullanılmıştır. Çalışma 50 fizik öğretmen adayıyla gerçekleştirilmiştir. Veriler iki bölümden oluşan bir anket aracılığıyla toplanmıştır. Veri toplama aracı olarak kullanılan anket formunun birinci bölümünü; öğrencilerin kişisel bilgilerini, bilgi ve iletişim teknolojilerini kullanma durumlarını betimsel olarak ortaya çıkartacak demografik bilgiler, ikinci bölümünü ise Kolb Öğrenme Stili Envanteri oluşturmaktadır. Araştırma sonunda öğrencilerin sırasıyla değiştiren, yerleştiren, ayrıştıran ve özümseyen öğrenme stiline sahip oldukları sonuçlar alan yazınında yer alan araştırmaların çoğunluğunun sonuçları ile farklılık göstermiştir. Elde edilen bulgulara göre bireylerin öğrenme stili, cinsiyet, motivasyon, akademik başarı, bilgi iletişim becerilerine göre farklılaşmamaktadır.

Anahtar sözcükler: öğrenme stili, motivasyon, akademik başarı, bilgi iletişim teknolojileri.

ABSTRACT: In this study, department of physics teacher candidates' dominant learning styles, academic success, gender, motivation information and communication technology were examined. Singular and relational survey model used in this study. The sample composed of 50 physics teacher candidates'. The data were collected through a paper based survey composed of two parts. In the first part of the survey there are fifteen items about personal information and demographic information about students'. In the second part is "Kolb Learning Style Inventory". The data were analyzed by using descriptive statistics and chi-square test. At the end of the study it has been found that physics teacher candidates' have learning styles in order of diverger, accomadator, converger and assimilator. These results have displayed difference to the results of majority studies in literature. According to the data collected, individuals' learning styles do not differ in gender, motivation, academic success and information communication technology.

Key words: learning styles, motivation, academic success, information communication technology.

İOS PLATFORMU İÇİN TIBBİ ETKİNLİK VE KONGRE UYGULAMASI

MEDICAL ORGANIZATION AND CONGRESS APPLICATION FOR İOS PLATFORM

Gökçe HAYTA

Başkent Üniversitesi, Müh. Fakültesi, Bilgisayar Müh. Bölümü
gokce.hayta@gmail.com.tr

Emre SÜMER

Başkent Üniversitesi, Müh. Fakültesi, Bilgisayar Müh. Bölümü
esumer@baskent.edu.tr

ÖZET: Her gün bir yenisinin eklendiği mobil uygulamalar günümüzün en popüler teknolojisi olarak görülmekte ve giderek yaygınlaşmaktadır. Bu nedenle teknolojik çözümlerin mobil cihazlar için geliştirilmesi bir zorunluluk haline almıştır. Bu çalışmada, ulusal ve uluslararası tıp kongreleri ve etkinlikleri için katılımcıların etkinlik öncesi, sonrası ve sırasında kullanabilecekleri iOS tabanlı bir mobil uygulama geliştirilmiştir. Böylece tıp kongrelerinde katılımcılara, kongre deneyimlerini arttıracak akıllı mobil çözümler üretilmesi hedeflenmektedir. Kongre esnasında katılımcıların ihtiyaçları ve gereksinimleri ile piyasada var olan örnek uygulamalar incelenmiş, kullanıcılara yeni çözümler ve hizmetler üretmeye yönelik çalışmalar yapılmıştır. Uygulama iOS tabanlı (iPhone ve iPad) cihazlar için geliştirilmiş olup uygulama yazılımı XCode kullanılarak gerçekleştirilmiştir. İçerikler için JSON web servisi kullanılmış olup uygulama ana menü üzerinden ulaşılabilecek birçok sayfadan meydana gelmektedir. Sonuç olarak, geliştirilen bu uygulama ile eğitim amaçlı düzenlenen kongrelerde verilere erişim hızı ve eğitim kalitesi önemli ölçüde arttırılmıştır.

Anahtar sözcükler: mobil uygulama, mobil kongre, iOS

ABSTRACT: Mobile applications, in which a new one emerged each day, appear to be the most popular technology and have become increasingly common. Therefore, development of the technological solutions for mobile devices becomes an obligatory. In this work, an iOS based mobile application was developed, which can be used by participants for national and international medical congresses before-after and during the activity. So, it is aimed to produce an intelligent mobile solution that will raise the congress experiences of the participants. To do that, the needs and requirements of the participants were examined during the congress. Besides, the model applications that are available in the market were also investigated. Further, preliminary studies were conducted on producing new solutions and services to users. The application was developed for devices running on iOS (iPhone and iPad) platform. The software of the application was implemented by using Xcode development environment. For the context of the application, JSON web service was used. The application is composed of several pages that can be reached over main menu. Consequently, the access speed to data was increased and the education quality during the congresses was improved.

Key words: mobile application, mobile congress, iOS

GİRİŞ

Günümüz teknolojisi her geçen gün değişmekte ve gelişmektedir. Mobil cihazlarla birlikte hayatımızın vazgeçilmez parçası olan teknoloji, hayatımızı kolaylaştırmak için her an bizimle. Her gün bir yenisinin eklendiği mobil uygulamalar günümüzün en popüler teknolojisi olarak görülmekte ve giderek yaygınlaşmaktadır. Bu nedenle teknolojik çözümlerin mobil cihazlar için geliştirilmesi bir zorunluluk haline almıştır.

Bu çalışma kapsamında Tıp kongrelerinde katılımcılara; kongre öncesinde, sonrasında ve süresince kullanabilecekleri, işlerini kolaylaştıracak servisler sunan akıllı bir uygulama geliştirilmiştir. Bu çalışmada mobil platform olarak iOS'un seçilmesinin temel nedeni; Şekil-1 ve Şekil-2'de görüldüğü gibi Android işletim sisteminin son yıllarda mobil uygulama pazarında daha büyük bir yere sahip olmasına rağmen, uygulamayı kullanacak olan hedef kitlenin yani tıp doktorların büyük bir çoğunluğunun iOS işletim sistemine sahip cihazlar kullanmasıdır.

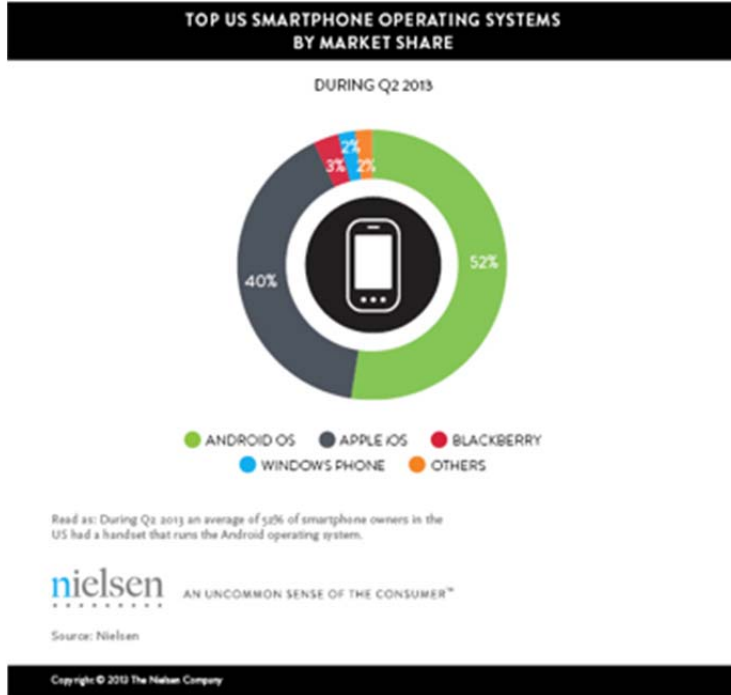

Şekil 1. Akıllı Telefon İşletim Sistemlerinin Pazar Payları

Smartphone manufacturer share by operating system

Q2 2012, US mobile subscribers

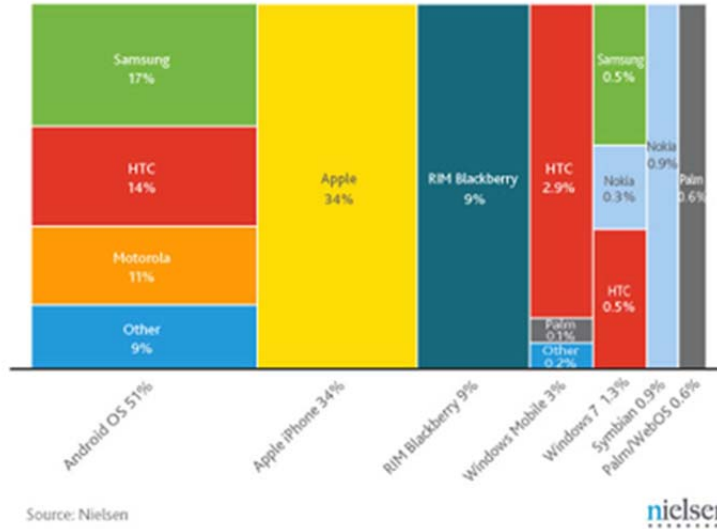

Şekil 2. Akıllı Telefon Kullanıcılarının Kullandıkları Cihaz Markaları ve İşletim Sistemleri

Uygulama yazılımı , XCode geliştirme ortamı kullanılarak gerçekleştirilmiştir. Kullanıcının uygulama içeriğini sürekli güncel olarak görüntüleyebilmesi için JSON web servisler kullanılmıştır. Ayrıca kullanıcıların interneti olmadığı durumlarda da içeriklere ulaşabilmeleri için güncel içerikler uygulama veritabanına kaydedilmektedir. Uygulama internete bağlı olarak her açıldığında uygulamanın daha güncel bir sürümü olup olmadığı kontrol edilmekte ve eğer varsa güncelleme yapılmaktadır. Bu sayede kongre esnasında bilimsel programda ya da herhangi bir etkinlikte bir güncelleme yapıldığında anlık olarak katılımcılara yansımaktadır.

UYGULAMA İÇERİĞİ

Uygulama ana menü üzerinden ulaşılacak birçok sayfadan meydana gelmektedir. Bu sayfalar incelenen yerli ve yabancı uygulama örnekleri ve kullanıcı ihtiyaçları göz önünde bulundurularak belirlenmiştir. Bunlar; “Şu Anda”, “Bilimsel Program”, “Konuşmacılar”, “Genel Bilgiler”, “Bildiriler”, “Medya”, “Duyurular”, “Arama” sayfalarıdır.

1. Şu Anda

Bu sayfada katılımcılar kongrede o esnada başlamış, devam eden ve yaklaşmakta olan oturumların listesini görüntüleyebilmektedir. Şekil 3'te de görüldüğü gibi ilk ekranda oturum ve salon isimleri görünmekte, içerik detay sayfasında ise oturumdaki konuşmalar ve konuşmacı bilgilerine erişilebilmektedir.

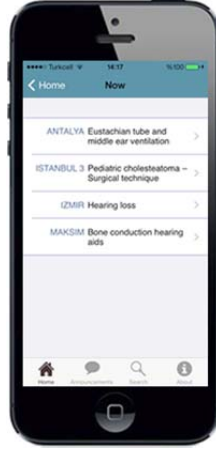

Şekil 3. Kongre Uygulamasının Şu Anda Sayfası

2. Bilimsel Program

Şekil 4'te de görüldüğü gibi Bilimsel Program sayfasından kongre programının tümüne, (gün veya kategori bazlı) salon adı, saati ve oturumun tipine bu sayfadan liste halinde ulaşılabilir. Detay sayfalarında ise oturumlarda yapılacak sunumların detaylarına erişilebilmektedir. Bu detaylar; oturum başkanı, konuşmacı bilgileri, salon yeri ve saat bilgisi, sunum özetleri ve ayrıca pdf'lerden oluşmaktadır.



Şekil 4. Kongre Uygulamasının Bilimsel Program Sayfası

3. Konuşmacılar

Kongreye katılan, sunum ya da diğer çalışmalarını gerçekleştiren ya da hazırlayan ekipte yer alan tüm yazar/konuşmacıların listesine, oturum – sunum bilgilerine ve bildiri özetlerine (ayrıca varsa bu özetlerin tam metinlerine) bu sayfadan ulaşılabilir.

4. Genel Bilgiler

Kongre ile genel bilgilere erişim imkanı sağlayan sayfadır. Bu sayfadan kullanıcı; kongre bilgilerine, kurul bilgilerine, kongre otellerine, sosyal programlara, transfer bilgilerine, salon planları vb. bilgilere erişebilmektedir.

5. Bildiriler

Konuşmacılar tarafından yayınlanmasına izin verilen bildiri listelendiği sayfadır. Bu sayfadan kullanıcılar bildiri özetlerine ve tam metin bildiriye erişebilmektedir.

6. Medya

Kongre esnasında çekilen salon ve genel alanların fotoğraflarının bulunduğu fotoğraf ve video galerileri ve kongre gazeteleri yer almaktadır.

7. Duyurular

Kongre öncesinde, kongre esnasında ve sonrasında yapılacak olan kongre ile ilgili duyurulara ve anlık bildirimlere bu sayfadan erişim sağlanabilmektedir.

8. Arama

Kongrede yer alan tüm çalışmaları, konuşmacı adı soyadı, sunum adı, oturum adı, bildiri adı kıstaslarına göre filtreleyerek kullanıcının aradığı bilgiye anında erişim sağlamasına ve ilgili sayfaya yönlendirmesine olanak sağlamaktadır.

9. Anketler

Kongre boyunca katılımcı memnuniyetini ölçmek, oturum ve sunumlarda dinleyicilere anlık sorular yöneltilmesine olanak vermektedir.

10. Favoriler

Kullanıcıların katılmayı düşündükleri oturumları bilimsel programdan favorilere eklemeleri sonucunda listelenen sayfadır. Ayrıca favorilere eklenen uygulamalar otomatik olarak kullanıcıya oturum öncesinde hatırlatma yapmaktadır.

SONUÇ ve ÖNERİLER

Sonuç olarak, geliştirilen bu uygulama ile eğitim amaçlı düzenlenen kongrelerde verilere erişim hızı ve eğitim kalitesi önemli ölçüde artırılmıştır. Ayrıca kongreler için kullanıcılara dağıtılacak olan basılı materyal miktarı önemli ölçüde azaltılmış, bu sayede doğaya verilen zarar azaltılmıştır. Bunlara ek olarak katılımcılara duyurular uygulama üzerinden anlık olarak ve daha hızlı bir şekilde ulaştırılmıştır. Geliştirilen bu uygulama ulusal ve uluslararası olmak üzere 7 farklı kongrede kullanılmıştır. Bu kongreler Apple Store’ da “TIHUD 2013”, “39. UHK”, “Uroonkoloji”, “ASNO 2014”, “NEFROLOJİ 2013”, “KLİMUD”, “Politzer 2013” isimleri ile bulunmaktadır.

Geliştirilen bu uygulamadaki amaç katılımcıların kongre deneyimlerini arttırmak ve teknoloji ile bütün içeriklere anında erişim sağlamlarına olanak vermek olmuştur. İleriki çalışmalarda katılımcıların kişisel bilgileri alınarak uygulamanın kişiselleştirilerek kullanıcıya özgü olması ve kişiye özel çözümler sunmasını sağlamak hedeflenmektedir.

KAYNAKLAR

- Altınova, H., Yalçın Y., Arslan S. (2008). *Web Servis Tabanlı Geliştirilen Mobil Uygulamalar: ODTÜ Mobil Öğrenci İşleri Bilgi Sistemi (MOİBS)*. Akademik Bilişim 2008, 167-170.
- Keskin Ö. N. & Kuzu A. (2011). *Mobil Akademik Araştırma Destek Sisteminin Teknolojik Yapısı*. 5th International Computer & Instructional Technologies Symposium, 22-24 September 2011 Fırat University, Elazığ, TURKEY.
- Harkawat, R. (2011). *Mobile Real Estate Agent For iPhone*. Master’s thesis, San Diego State University, USA.
- Pilomia, J. (2011). *User Experience in Mobile Application Development: Developer and End-user Perceptions*. Master’s thesis, University of Tampere, Finland.
- Attewell J. *From Research and Development to Mobile Learning: Tools for Education and Training Providers and their Learners*. Learning and Skills Development Agency ,UK

BİLİM İÇİN BİR BULUŞMA NOKTASI: CAFÉ SCIENTIFIQUE

A MEETING POINT FOR SCIENCE: *CAFÉ SCIENTIFIQUE*

Sultan ÇIKRIK
Gazi Üniversitesi
sultanaltunsoy@gazi.edu.tr

Mustafa YEL
Gazi Üniversitesi
musyel@gazi.edu.tr

ÖZET: Bu çalışmanın amacı, *Café Scientifique* ile ilgili alan yazını incelenmek, bilgileri sentezlemek ve uygulama örneklerini sunmaktır. *Café Scientifique*, kafe gibi informal bir ortamda, her yaşta ve seviyeden katılımcıların güncel ya da sosyo-bilimsel konularda dinleme, soru sorma, konuşma ve tartışma gibi aktiviteleri yapabileceği bilimsel bir programdır. Rahat bir atmosferde, daha önceden belirlenmiş bir soru ya da konu üzerinde rehberli bir tartışma yürütülmektedir. Bu programda herhangi bir sunum ya da resmi bir anlatım yapılmamaktadır. *Café Scientifique* programının, bilimsel okuryazarlık için alternatif bir etkinlik olabileceği düşünülmektedir.

Anahtar sözcükler: *Café Scientifique*, bilim insanı, bilimsel okuryazarlık, bilimin doğası

ABSTRACT: The aim of this study, to investigate the literature on *Café Scientifique*, to synthesize information and to present application examples. *Café Scientifique* is a scientific program in which participants from all ages and levels can realize activities such as listening, asking questions, talking, and, debating about actual or socio-scientific issues in an informal environment such as café. A guided discussion about predetermined question or subject is conducted in a relaxed atmosphere. In this program, any presentation or formal lecture is made. It is thought that, *Café Scientifique* could be an alternative activity for scientific literacy.

Key words: *Café Scientifique*, scientist, scientific literacy, nature of science

FEN BİLGİSİ ÖĞRETMEN ADAYLARININ ORGANİK BİLEŞİKLERİ IUPAC SİSTEMİNE GÖRE ADLANDIRMADA KARŞILAŞTIĞI ZORLUKLAR

Doğan DOĞAN

Organik kimya, fen bilgisi öğretmen adaylarının mezuniyetleri için almaları gereken temel alan derslerinden biridir. Fen bilgisi öğretmen adaylarından bir kimyager ya da kimya öğretmeni kadar organik kimya bilgisine sahip olmaları beklenmez. Ancak organik kimyanın günlük yaşamdaki yeri ve organik kimyada temel kavramlar hakkında yeterli bilgiye sahip olmaları ve organik bileşikler IUPAC kurallarına göre adlandırabilmeleri gerekir. Yapılan çeşitli araştırmalar, organik kimya konularının farklı öğrenim düzeyindeki öğrenenler tarafından zor veya çok zor olarak algılandığını göstermiştir. Örneğin, İrlanda da farklı eğitim düzeyindeki öğrencilerle yapılan bir araştırmada (Childs & Sheehan, 2009), organik tepkime mekanizmaları ve organik sentez konularının çok zor, organik bileşiklerin adlandırılmasının ise ortanın üzerinde zor bir konu olarak algılandığı belirlenmiştir. Yakın zamanda yapılan başka bir araştırmada (Adu-Gyamfi, 2013) ise, lise öğrencilerinin organik bileşikler IUPAC sistemine göre adlandırmadaki performansları belirlenmeye çalışılmıştır. Mevcut literatür incelendiğinde, organik bileşikler IUPAC kurallarına göre adlandırmada karşılaşılan güçlükler ile ilgili herhangi bir çalışmaya rastlanılmamıştır. Bu nedenle araştırmada, fen bilgisi öğretmen adaylarının organik bileşikler adlandırılmada karşılaştıkları zorluklar tipleri belirlenmeye çalışılmıştır. Bu amaçla, 2012-2013 akademik öğrenim yılı bahar döneminde, ülkemizin kuzey batısında yer alan bir üniversitede öğrenim gören toplam 125 gönüllü öğretmen adayına, adlandırma konusunun bitiminde araştırmacı tarafından geliştirilen toplam 25 maddelik Organik Bileşikler Adlandırma Zorlukları anketi yöneltilmiştir. Verilerin analizinden, katılımcıların organik bileşikler adlandırmada zorlandıkları noktalar tespit edilmiştir. Bu çalışmanın, organik bileşiklerin adlandırılmasının öğretime katkı sunacağı umulmaktadır.

Anahtar Kelimeler: organik bileşikler, adlandırma, öğrenme zorlukları, fen öğretmeni adayları

oooooooooooooooo

DIFFICULTIES ENCOUNTERED BY PRESERVICE SCIENCE TEACHERS IN NAMING ORGANIC COMPOUNDS ACCORDING TO IUPAC SYSTEM

Doğan DOĞAN

Organic chemistry is one of the main course of preservice primary science teachers as a requirement for their major. Preservice science teachers cannot be expected to have mastered in the knowledge of organic chemistry as a chemistry teacher or chemist. However, they should have enough knowledge about the place of organic chemistry in daily life, basic concepts in organic chemistry, and be able to name the organic compounds according to IUPAC rules. Various studies have showed that organic chemistry topics perceived as difficult or very difficult by learners at different educational levels. For example, it was determined that organic reaction mechanisms and organic synthesis topics were perceived as very difficult, and naming organic compounds as moderately difficult in a study carried with students at different educational levels in Ireland (Childs & Sheehan, 2009). Also in another study carried out recently (Adu-Gyamfi, 2013), performance of a group of high school students in naming organic compounds according to the IUPAC system was tried to be determined. The available literature was examined, but it was not found any study about the difficulties encountered in naming organic compounds according to the IUPAC rules. Therefore, in this study, types of difficulties preservice science teachers encountered in naming organic compounds were tried to be determined. To this end, in the spring semester of 2012-2013 academic year, a 25-item Likert-style questionnaire (Organic Compounds Naming Difficulties Questionnaire) developed by the researcher was given to a total of 125 volunteer preservice primary science teachers studying at a university located in the north west of Turkey after completing the nomenclature unit. From the analysis of the data, difficult points in naming the organic compounds encountered by the participants have been identified. It is hoped that the current study will contribute to the teaching of organic compounds nomenclature.

Keywords: organic compounds, nomenclature, learning difficulties, preservice science teacher

TEACHING AND LEARNING IN HIGHER EDUCATION

Professor Moofik Al-Tai

Staffordshire University, United Kingdom

Email: m.al-tai@staffs.ac.uk

ABSTRACT: The success of Higher Education (HE) Institutions depends on the success of their students and the quality of the student learning experience will increasingly be a key determinant HE institutions success in the context of the emerging competitive higher education landscape. The HE institution's Strategic Framework for Learning and Teaching reflects the HE institution's ambition to support students to be successful at each stage of their engagement with them - from first contact through to successful entry into employment.

This paper explores effective ways of teaching and learning in higher education. It focuses especially on teaching and learning to achieve equality in diverse student access, and to achieve equity and fairness in student success and outcomes from higher education.

This paper will also deal with the current higher education teaching and learning issues and challenges. It will consider issues relating to various methods of learning including class room based learning (face to face learning), e-learning, work-based learning and distance learning. E-learning is well suited to distance learning and flexible learning, but it can also be used in conjunction with face-to-face teaching, in which case the term blended learning is commonly used. HE institutions may explore these learnings in order to improve their students' success.

Keywords: Teaching, Learning, Higher Education.

INTRODUCTION

Higher Education students should have the opportunity to develop the study skills and outlook necessary to support their currency with their chosen subject throughout their future careers. To this end the HE institution's learning and teaching strategy aims to provide a resource based learning environment with an emphasis on student opportunity rather than simple direct teaching. Each student is a partner in the learning experience and is expected to take responsibility for his/her study. The HE institutions should lay emphasis on the role of the lecturer as a learning facilitator who enables the student to take a responsibility for her/his own learning.

Student learning opportunities include e-learning, classroom-based learning; work-based learning and distance learning. These learnings involve a broad spectrum of activities appropriate to the learning outcomes and the assessment methods. These activities range from entirely self-managed study, timetabled formal lectures, tutorials, laboratory based work and presentations. Students have opportunities to use and develop theoretical knowledge, computer based models, and to design, implement and test. The transferable skills of presenting, writing, discussing, working with others, and managing one's own time are developed throughout the programme of study.

Practical work is an essential feature of many programmes of study and may take place in a number of settings including the computer laboratory or classroom. Practical work is required for preparation, assessment and other course work. As students' progress, directed reading becomes more demanding in line with the intellectual development required at all levels.

Students are encouraged to undertake independent learning to extend the material presented. The value of self-gained knowledge and understanding is emphasised both as an essential skill/practice for lifelong learning and as an expectation on professionals to continue their professional development.

E-LEARNING

E-learning is the use of electronic media and information and communication technologies in education. E-learning is broadly inclusive of all forms of educational technology in learning and teaching. E-learning is inclusive of, and is broadly synonymous with multimedia learning, technology-enhanced learning, computer-based instruction, computer-based training, computer-assisted instruction or computer-aided instruction, internet-based training, web-based training, online education, and Virtual Learning Environments (VLE). These alternative names emphasize a particular aspect, component or delivery method.

E-learning includes numerous types of media that deliver text, audio, images, animation, and streaming video, and includes technology applications and processes such as audio or video tape, satellite and computer-based learning, as well as local intranet/extranet and web-based learning. Information and communication systems, whether free-standing or based on either local networks or the Internet in networked learning, underlay many e-learning processes[1].

WORK BASED LEARNING

Work Based Learning (WBL) is a modern way of creating Higher Education (HE) level learning in the workplace. Its special work-linked features enable learning to be centred and take place throughout the working environment [2].

WBL involves HE institutions, students and employers working in partnership to provide high-quality learning for students. This includes a wide range of practice, ranging from fully-integrated WBL programmes, through work placements and practice-based learning, to the accreditation of employer provision by HE institutions [3].

WBL can help employees in making career decisions, developing job skills relevant to future employment, achieving a recognised academic qualification, enhancing their academic knowledge, achieving a recognised academic qualification and improving their personal and professional development [4].

As the HE institution builds relationships with employers, they must then transfer the appropriate information through materials. These materials represent the knowledge the HE institution holds that must be given to the students on the programme and employers themselves. With this knowledge employers can develop an understanding of the programme of content that will be given to their employees. The employees themselves will be able to have this foundation of understanding and then use the teaching materials to learn the programme of content and fully understand the subject in which they wish to build and develop their knowledge.

DISTANCE LEARNING

Distance Learning is a modern way of studying for an undergraduate, Master or PhD degree courses without actually being on site at the students chosen HE institution by using new technology in the delivery of subjects associated with these courses, including the use the VLE through the Internet.

Instead of attending lectures, students study online, attending ‘virtual’ tutorials and submit their assignments over the Internet. They can be in the same country as the HE institution, or overseas.

Distance learning gives the students the opportunity to study through a university that they would not necessarily be able to attend due to their physical location, or to fit study around work or other commitments.

Distance learning, presentation and interaction with materials must be approached in an alternative way to when students are regularly attending the campus, and on site at teaching locations. When a student is on campus, they are learning in direct contact with the Higher Education (HE) institution and academically trained members of staff that can facilitate their learning with their direct knowledge and supporting materials. However, a student who is off campus, and receives the course programme through means of distance learning, learns through another channel, and must therefore have materials that cater to the fact they are in a remote location.

Distance learning does not always meet the requirements of courses such as Engineering and Technology related courses where the physical classroom attendance is mandatory to complete the course. In this case a blended learning may be required.

BLENDED LEARNING

Blended learning is a combination of face-to-face learning, online assessment and feedback, mediated instruction (E-Learning) and traditional study methods, as illustrated in Figure 1 [5].

Because of the face-to-face learning sessions, blended learning can be applied to engineering and technology related courses which require a significant amount of laboratory based work in order to satisfy the accreditation requirements by professional bodies.

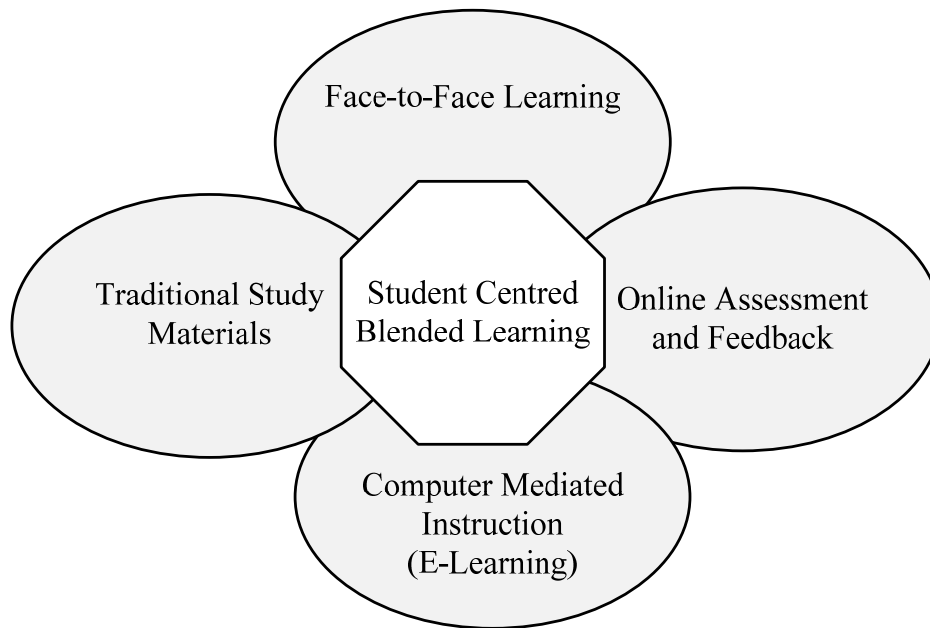

Figure 1: Blended Learning Model

LEARNING MATERIALS IN DISTANCE LEARNING ENVIRONMENT

There are four means in which materials work in the distance learning environment:

(a) Material-Based Learning

This is where learning resource materials made available to the students by the course programme for the sole basis for their understanding of the course content.

b) Direct Communication

Materials may also be provided in the situation where learning is supported from the HE institution remotely from the student.

(c) Lecturer Delivery in the Students Place of Work

Another option would be for the HE institution to physically send relevant staff to the employer at regular intervals to deliver the materials.

(d) Virtual Learning Environment

The VLE is a system which changes the way materials are delivered. The VLE is designed to facilitate the delivery of course programmes to students, through providing a means in which the students can learn without having to be in the classroom.

LEARNING OPPORTUNITIES

Examples of good learning opportunities with reference to relevant assessment methods are presented below:

Laboratory assignments / practical work / log book records / reports - Computer based exercises - Simulation exercises:

Many learning opportunities are provided by practical work of some form. This occurs for example in laboratory based assignments for which students maintain a log book (whilst they are in the laboratory) and produce a report. The practical work may take the form of undertaking experimental test measurements, building items of technical equipment, undertaking design work, implementing web-based or other computer-based or media-based code or solution, or implementing an individual design project. Technical instruction and support should be available wherever appropriate. Generally practical work is linked to theoretical concepts and analytical skills developed in lectures and tutorials.

Presentations and oral examinations:

Opportunities are provided in assignments in which presentations, as well as project management techniques, team working, design and written reports, play a part.

Problem solving exercises:

Problem solving activities are normally undertaken by the students at all levels. As a formal component of subjects within the curriculum of the course, tutors set problems for students to tackle, and on which assessment may be based. The level of challenge ranges from fundamental knowledge to those that develop a deeper understanding. These are often generated entirely by the subject tutors based on their own experience.

Design tasks:

Design skills (if required by the course) should be introduced and developed through tutorials and problem solving exercises. Design requires knowledge and understanding, a requirement and specification, the tools and techniques to design, realise and test, and the project management skills to manage the process.

Individual projects and report:

Many courses require the completion of individual projects. Students may require to and produce a proposal, and final report. In this case students should review published literature and other relevant published works, and to set their work in the context of other work in the field.

ASSESSMENT METHODS

The assessment methods used with the programme of study are varied, formative and develop students' transferable skills as well as their technical ability. Students' ability to plan, judge, communicate complex issues, solve problems logically, and develop original solutions, in appraising critically the work of others, and in managing their own learning are all significant contributors to determining a students' mark for a subject within the programme of study. In addition a student's technical understanding of the context of their work alongside that of others, of the breadth of their subject of study, and of the depth of their specialist area of study, also are key to the assessment process.

Assessment methods applied should include:

- Unseen examinations / class tests.
- Laboratory assignments / practical work / log book records / reports.
- Learning Portfolio
- Case Studies
- Presentations and oral examinations
- Problem solving exercises
- Essay assignments
- Assessments of work-based learning
- Design tasks
- Computer-based/Simulation exercises
- Poster displays
- Individual projects and reports and Graduate Show presentations

LEARNING RESOURCES

Many HE institutions have made substantial investments in information and learning technology and many have bespoke Learning Resource Centres which are curriculum-zoned. These resources enhance the delivery of courses in the classroom and remotely through the Internet.

HE institutions normally have an extensive range of journals; including those online and relevant to higher level study. A positive and distinctive feature is that students should be able to have access to the online learning resources of the institution.

FEEDBACK ON STUDENT WORK

There should be an agreed point of reference and common starting point between students and staff as to what constitutes the purpose and use of feedback as part of a learning process.

The feedback should generate a series of questions for the students which makes them think about their learning now, and what they need to do to develop their learning in the future. This will enable them to understand the purpose of the feedback in each specific context; create the capacity to developing evaluative judgment; the ability to review their own performance against professional and academic criteria; and to think about learning strategies they need to develop in the future.

The dialogue and understanding that emerges from the feedback should be applicable both to the current debate and also contain elements that are able to be translated to a range of current and future learning situations. As the student progresses through their learning journey they should be developing a more sustained and sophisticated approach to their learning, culminating in the expression of the graduate attributes appropriate to their level and subject specialism.

Feedback isn't simply an activity that takes place after assessment – it isn't something that is simply done to students! Feedback that is effective and timely occurs when students know when they need it, recognise what they want it for, and know how to ask for it in a way that is appropriate to their needs.. It is multi-faceted both in terms of content and format.

QUALITY ASSURANCE

HE institutions are responsible for ensuring that appropriate standards are being achieved and a good quality education is being offered.

Academic standards are a means of describing the level of achievement that a student has to reach to gain an academic award.

Academic quality is a means of describing how well the learning opportunities available to students help them to achieve their chosen programme of study. It is about making sure that appropriate and effective teaching, support, assessment and learning opportunities are provided for students.

ETHICS

Ethics is a set of principles to determine correct conduct. It is a system of moral values and moral choices made by the ethical person. It is based on moral values and rules and determines what is right and what is immoral. In the workplace, it is the rules or standards defining the conduct of a person, or members of a profession.

Handling ethical issues is an important element in many academic courses, in particular when undertaking work-based learning. Academic honesty and project integrity are vital to student's success. Students need to be aware of the skills needed to understand ethical issues.

When working in professions, the HE institution involved and the students must adhere to ethics and practices of the HE institution.

Ethical issues revolve around the importance and sensitivity of the materials and records of the business. It also includes the codes of practice required by the professional bodies and how the student responds and adheres to the code.

Within ethics confidentiality is an important factor. Confidentiality means holding information from an individual or about an individual throughout the professional relationship secure and secret from others. Confidentiality is seen as important to the maintenance of the relationship and the development of trust between individuals.

CONCLUSION

This paper has dealt with the current higher education teaching and learning issues and challenges. The paper presented methods, guidelines and procedures for teaching and learning in Higher Education.

It must be noted that, students on each course are different, and this must be reflected in the range and diversity in the materials provided. Teaching and learning must be supported depending on the course studied, with the level of materials equal to the level of the course. Materials developed and delivered must take into account that courses will undoubtedly place a great emphasis on all types of learning and the materials should take this into consideration.

When HE institutions deliver courses by distance learning they need to make sure this type of learning may not always meet all the teaching and learning needs and blended learning may be required.

Focused attention should be given to ethical issues and relationships connected with teaching and learning. HE institutions and students must adhere to ethics and practices of the HE institutions.

Good feedback on student work should create the environment whereby effective and productive learning is taking place, leading to the emergence of a flourishing learning community.

REFERENCES

- [1] <http://en.wikipedia.org/wiki/E-learning>
- [2] Al-Tai, M 'Work Based Learning', Professors and Head of Electrical Engineering (PHEE) Conference, January 2009, London, UK. www.phee.org/Conf2009/AlTai.pdf
- [3] Employer engagement through work-based learning, May 2010. www.qaa.ac.uk/events/EmployerEngagementWBL_May10/default.asp
- [4] Staffordshire University Projects, UK. www.staffs.ac.uk/about_us/projects/
- [5] 5th International Computer & Instructional Technologies Symposium, 22-24 September 2011, Firat University, ELAZIĞ- TURKEY.

DİNAMİK GEOMETRİ YAZILIMI GEOGEBRA'NIN KULLANIMININ ÖĞRENCİ BAŞARISI VE KALICILIK ÜZERİNDEKİ ETKİSİ¹

THE EFFECTS OF USE OF A DYNAMIC GEOMETRY SOFTWARE GEOGEBRA ON STUDENTS' ACHIEVEMENT AND RETENTION LEVELS

Metehan MERCAN
Pakmaya ORTAOKULU
mthn_988@hotmail.com

Mine AKTAŞ
Gazi Üniversitesi
Mineaktas07@gmail.com

ÖZET: Bu çalışma, 7. sınıf matematik dersi müfredatında yer alan “Dönüşüm Geometrisi” alt öğrenme alanında bir dinamik geometri yazılım programı olan GeoGebra'nın öğrenci başarısına ve kalıcılığa etkisini incelemek amacıyla yapılmıştır. Bu çalışmada, araştırma yöntemlerinden ön-test, son-test kontrol gruplu deneysel çalışma uygulanmıştır. Bu çalışmanın çalışma grubunu 2011-2012 eğitim öğretim yılı bahar döneminde, Ankara ilinde bulunan, MEB'e bağlı bir ilköğretim okulunda öğrenim gören toplam 37 öğrenciden oluşan iki ilköğretim 7. sınıf şubesi oluşturmuştur. GeoGebra'nın öğrenci başarısına ve kalıcılığa etkisini tespit edebilmek amacıyla deney (17) ve kontrol grupları (20) oluşturulmuştur. Deney grubu için GeoGebra destekli MEB müfredat programına uygun iki haftalık ders planlanmıştır. Ders süresinde GeoGebra'nın etkin kullanımını içeren, yapılandırılmış GeoGebra inşa aktiviteleri öğrenme ve öğretim süresi boyunca öğrencilerle paylaşılmıştır. Eş zamanlı olarak, kontrol grubunda MEB müfredat programına uygun olarak eğitime devam edilmiştir. Sınıf içi aktivitelerden önce ve sonra olmak üzere, hazırlanan konu başarı testi gruplara, ön-test, son-test ve kalıcılık testi olarak uygulanmıştır. Verilerin çözümlenmesi, SPSS-17.0 programı kullanılarak bilgisayar ortamında yapılmıştır. Grupların erişim düzeyleri arasındaki farkın belirlenmesi için bağımlı ve bağımsız örneklemeler için T testleri kullanılmıştır. Testler ve gruplar arasında yapılan karşılaştırmalar sonucunda, GeoGebra'nın öğrencilerin öğrenme ve başarılarını olumlu yönde etkilediği görülmüştür. Kalıcılık testi sonuçlarında da deney grubu lehine anlamlı bir fark bulunmuştur.

Anahtar sözcükler: Bilgisayar Destekli Öğretim, GeoGebra, Dönüşüm Geometrisi

ABSTRACT: The aim of this study is to find out the effects of a dynamic geometry software program GeoGebra in teaching the subject of “Transformation Geometry”, which is a part of primary school seventh grade Math class, on students' achievement and retention levels. This is an experimental study in which pre-test, post-test and control group have been used. The participants of the study are 37 seventh grade students divided into two classrooms in a state primary school in Ankara. The study was conducted in Spring Term of 2011-2012 academic year. To find out the effects of GeoGebra on students' achievement and retention levels, an experimental group consisting of 17 students and a control group consisting of 20 students have been assigned. The experimental group was offered a GeoGebra based course for two weeks in accordance with Ministry of National Education curriculum. During this 2-week-course, students were provided with GeoGebra construction activities involving active use of GeoGebra. Meanwhile, control group was taught the same units only in accordance with the curriculum of Ministry of National Education. Achievement tests prepared for the particular units were administered to both groups as pre-test, post-test and retention tests before and after the activities in class. Data analysis has been conducted through SPSS17.0. Independent sample t-test and paired sample t-test have been used in order to find out the difference between the achievement levels of the groups. As a result of data analysis, GeoGebra was found to affect the achievement and learning of students positively. Moreover, there was significant difference favoring the experimental group according to retention test results.

Key words: Computer-based Teaching, GeoGebra, Transformation Geometry

¹Bu bildiri, Mercan'ın (2012) *İlköğretim 7. Sınıf Matematik Dersine Ait “Dönüşüm Geometrisi” Alt Öğrenme Alanının Öğretiminde Dinamik Geometri Yazılımı Geogebra'nın Kullanımının Öğrenci Başarısı Ve Kalıcılık Üzerindeki Etkisi* adlı Yüksek Lisans tezinden üretilmiştir.

KAVRAMSAL DEĞİŞİM METİNLERİNİN MADDENİN AYIRT EDİCİ ÖZELLİKLERİNİ ANLAMAYA ETKİSİ

THE EFFECTS OF CONCEPTUAL CHANGE TEXTS ON THE UNDERSTANDING OF THE DISTINGUISHING FEATURES OF THE SUBSTANCES

Sertaç SİĞA

Niğde University Educational Sciences Primary Education Department of Science Education
sertacsiga@hotmail.com

Gökhan ÖZDEMİR

Niğde University Faculty of Education Department of Science Education
gokhanozdemir@nigde.edu.tr

ÖZET: Bu çalışmanın amacı, öğrencilerin ‘Maddenin Ayırt Edici Özellikleri’ konusundaki kavram yanlışlarının kavramsal değişim metinleri kullanılarak giderilmesini sağlamaktır. Bu deneysel çalışmanın örneklemini kavramsal değişim metinleriyle dersi alan 24 beşinci sınıf öğrenci ile geleneksel öğretim yöntemiyle dersi alan 24 beşinci sınıf öğrenciden oluşmaktadır. Araştırmacılar tarafından oluşturulmuş kavram yanlışları testi deney ve kontrol grubu öğrencilerine ön ve son test olarak uygulanmıştır. Bu uygulamaların ön test ve son test sonuçları Mann-Whitney U ve Wilcoxon İşaret Sıraları Testleri kullanılarak analiz edilmiştir. Analiz sonuçları değerlendirildiğinde, kavramsal değişim metinleri ile dersi alan öğrencilerin kavram yanlışlarının giderilmesinde istatistiksel olarak anlamlı düzeyde gelişme gösterdiği tespit edilmiştir.

Anahtar sözcükler: maddenin ayırt edici özellikleri, kavram yanlışları ve kavramsal değişim metinleri.

ABSTRACT: The purpose of this study is to remedy the students’ misconceptions on the topic of distinguishing features of the substances by using conceptual change texts. The sample of this experimental study was consisted of 24 fifth grade students who took the course within conceptual change texts as the experimental group and 24 fifth grade students who took the course within traditional methods as the control group. A conceptual change test who developed by the researchers was assigned to the groups as pre and post tests. The data obtained from the results of pre and post tests were analyzed via Mann-Whitney U and Wilcoxon Signed Rank Tests. The result of the study indicated that the students who took the course within conceptual change texts displayed statistically meaningful development in remediation of their misconceptions.

Key words: distinguishing features of the substances, conceptual change, and conceptual change texts.

MAKİNE ÖĞRENMESİ ALGORİTMALARI KULLANILARAK KALP HASTALIĞI TESPİTİ

DIAGNOSIS OF HEART DISEASE BY USING MACHINE LEARNING ALGORITHMS

Ömer Faruk BOYRAZ

Sakarya Üniversitesi Teknoloji Fakültesi Elektrik Elektronik Mühendisliği
oboyraz@sakarya.edu.tr

Volkan SEYMEN

Sakarya Üniversitesi Teknoloji Fakültesi Bilgisayar Mühendisliği
vseymen@sakarya.edu.tr

Mehmet Recep BOZKURT

Sakarya Üniversitesi Mühendislik Fakültesi Elektrik Elektronik Mühendisliği
mbozkurt@sakarya.edu.tr

Özdemir ÇETİN

Sakarya Üniversitesi Teknoloji Fakültesi Elektrik Elektronik Mühendisliği
ocetin@sakarya.edu.tr

ÖZET: Başlıca görevi vücuda kan pompalamak olan kalp, metabolizma faaliyetleri sonrası oluşan artık ürünlerin vücuttan uzaklaştırılması, vücut ısısının düzenlenmesi, asit-baz dengesinin korunması, hormonlar ve enzimlerin vücutun gerekli bölgelerine taşınması gibi görevleri yapar. Hareketsiz yaşam tarzı, aşırı yağlı yiyecek tüketimi, alkol, sigara kullanımı gibi etmenler kalbin çalışmasını olumsuz etkileyerek kalp hastalıklarının oluşmasına neden olabilmektedir. İnsan vücudu için birinci derecede hayati öneme sahip kalpte oluşan hastalıkların erken bir aşamada tespit edilmesi oldukça önemlidir. Bu çalışmada kalp damar hastalıklarının teşhisi için Yapay Sinir Ağları (YSA) tabanlı bir sistem kullanılmıştır. Bu sistem ile bir veri setinde bulunan kalp hastası olan ve olmayan katılımcılardan alınan veriler başarılı bir şekilde eğitilip sonrasında YSA ve Bayes Sınıflandırma yöntemleri ile test edilmiştir. Ardından iki farklı test çıktılarından elde edilen sonuçlar doğruluk performansı açısından karşılaştırılmıştır.

Anahtar sözcükler: kalp, hastalık teşhis, bayes algoritması, yapay sinir ağları, sınıflandırma

ABSTRACT: The purposes of your heart are to pump fresh blood to the organs and tissues of your body, after metabolism activities occurs to remove waste products from the body, regulation of body temperature, protection of acid-base balance, hormones and enzymes to move to the necessary parts of the body. The motionless life, making excessive and chronic alcohol, smokes, excessive consumption of fatty foods can cause heart diseases. Diagnosis of the heart diseases at an early stage is important for human body. In this study, a system depend on artificial neural network (ANN) is used for analyse of heart diseases. The heart disease dataset have been classified as absence or presence of heart disease. Furthermore, results of ANN have been compared with Naive Bayes classification results and than obtained test results from the output were compared in terms of performance.

Key words: heart, diagnosis of disease, bayes algorithm, artificial neural network, classification

GİRİŞ

Kalp hastalıkları dünya çapındaki ölümlerin en büyük nedenlerinden birisidir. Son yirmi yıl içinde, bu hastalıklardan ölüm oranları yüksek gelirli ülkelerde düşmüş olsa da hastalık ve ölüm oranları düşük ve orta gelirli ülkelerde şaşırtıcı derecede hızlı bir şekilde artmıştır.[1] Koroner Arter Hastalığı, koroner arterlerin duvarlarında oluşan plaklardan ötürü ortaya çıkan bir hastalıktır. Koroner kalp hastalığı veya kısaca CHD (Coronary Heart Disease) olarak da adlandırılır.[2] Bu hastalıklar genellikle yaşlı yetişkinlerde görülse de özellikle ateroskleroz, (damar tıkanıklığı) geçmiş çocukluk çağına dayandığından birincil korunma çabaları yaşamın erken dönemlerinde başlamalıdır.[3]

Birçok rahatsızlıkta olduğu gibi kalp hastalığında erken teşhisi ve tedavisi insan hayatı için son derece önemlidir. Günümüzde hastalıkların teşhisinde biyomedikal alanda birden çok farklı sınıflandırma yöntemlerinin kullanılması yaygın bir hale gelmiştir. Bunun sebebi ise bilgisayar tabanlı sınıflandırma yöntemleri ile doğruya yakın sonuç elde edilmesi gösterilmektedir.

Bu çalışmada, kalp hastalıklarının teşhisi için literatürde en çok tercih edilen sınıflandırma yöntemlerinden birisi olan yapay sinir ağları (YSA) kullanılmıştır. Bu sistem sayesinde katılımcılardan alınan çeşitli veriler ile kalp hastalığı teşhisi yapılmıştır. YSA ile elde edilen performans sonuçları Naive Bayes sınıflandırma algoritması ile karşılaştırılmış ve YSA'nın daha başarılı bir sınıflandırma yaptığı gözlenmiştir.

MATERYAL ve YÖNTEM

Yapılan bu çalışmada YSA sınıflandırması ile kalp hastalığı tespiti yapılmış ve bulunan sonuçlar diğer bir sınıflandırma yöntemi olan Naive Bayes algoritması kullanılarak karşılaştırılmıştır. Kalp hastası olan ve olmayan hastaların tespiti için kullanılan veriler UCI Machine Learning Respository [5] veri tabanındaki "Heart Disease" veri kümesinden alınmıştır.

Veri Seti

Yapılan çalışmada kullanılan veri seti için UCI Machine Learning Respository veri tabanında bulunan kalp hastalığı veri seti (Heart Disease Dataset) kullanılmıştır. Kullanılan veri setindeki datalar 150 kalp hastası olan ve 120 kalp hasta olmayan kişiler olmak üzere toplamda 270 adet katılımcıdan alınmıştır. Alınan veri setindeki toplam 13 özellik için katılımcılar üzerinde çeşitli ölçümler yapılmıştır ve bu özellikler tablo 1' de detaylı olarak verilmiştir.

Tablo 1. Kalp Hastalığı Veri Seti Özellikleri

Özellik No	Özellik Bilgisi
1	Hastanın yaşı
2	Hastanın cinsiyeti
3	Göğüs Ağrısı Şiddeti (1-4)
4	Tansiyon (Dinlenme Hali)
5	Kandaki Serum kolesterol miktarı (mg / dl)
6	Açlık kan şekeri > 120 mg / dl
7	Dinlenme hali elektrokardiyografi sonuçları (0,1,2)
8	Ulaşılan maksimum kalp atış hızı
9	Egzersiz nedenli angina
10	Egzersize bağlı ST depresyonu
11	ST segmenti tepe eğimi
12	Floroskopi ile bulunan ana damarların sayısı (0-3)
13	Akdeniz anemisi 3=normal 6=sabit defekt 7=tersinir defekt

Yapay Sinir Ağları

Yapay sinir ağı; elektronik ortamda insan beyninin sinir hücrelerinden oluşmuş katmanlı yapısının tüm fonksiyonlarıyla beraber gerçeklenmeye çalışılan modellenmesidir. Elektronik ortam ile belirtmek istenen donanım ve yazılımdır. Bir yapay sinir ağı hem yazılımsal hem de donanımsal olarak oluşturulabilir. Çok katmanlı yapay sinir ağları çalışma adımları şunları içerir:

- Örneklerin toplanması
- Ağın topolojik yapısının belirlenmesi
- Öğrenme parametrelerinin belirlenmesi
- Ağırlıkların başlangıç değerlerinin verilmesi
- Öğrenme setinden örneklerin seçilmesi ve ağın eğitilmesi
- Öğrenme esnasında ileri hesaplama yapılması
- Çıktının beklenen ile karşılaştırılması
- Ağırlıkların güncellenmesi

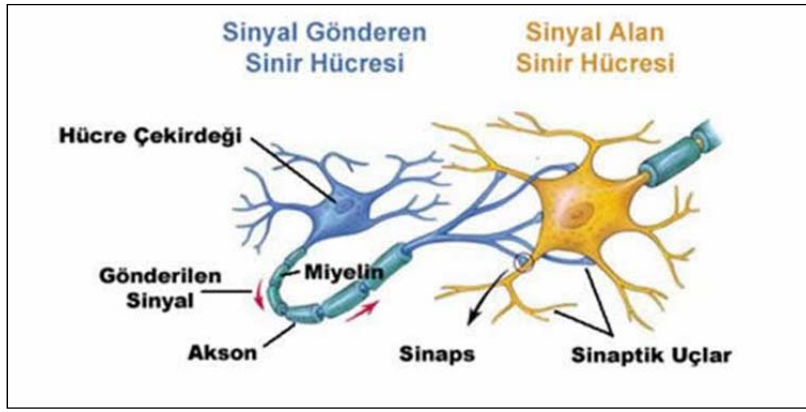

Şekil 1. Sinir Hücresi Yapısı

YSA'ları, ağırlıklandırılmış şekilde birbirlerine bağlanmış birçok işlem biriminden (nöronlar) oluşan matematiksel sistemlerdir. Bir işlem birimi, aslında sık sık transfer fonksiyonu olarak anılan bir denklemdir. Bu işlem birimi, diğer nöronlardan sinyalleri alır; bunları birleştirir, dönüştürür ve sayısal bir sonuç ortaya çıkarır. Genelde, işlem birimleri kabaca gerçek nöronlara karşılık gelirler ve bir ağ içinde birbirlerine bağlanırlar; bu yapı da sinir ağlarını oluşturmaktadır. Günümüzde yapay sinir ağlarında Perceptron, Adaline, Çok Katmanlı Algılayıcı Modeli(Hatayı Geriye Yayma), Vektör Kuantizasyon Problemleri, Hopfield Ağları ve Elman Ağları gibi bir çok öğrenme modeli vardır[4,6].

Yapılan bu çalışmada YSA Çok Katmanlı Algılayıcı Modeli kullanılmıştır. İleri beslemeli geri yayımlı Çok Katmanlı Ağ Modeli Şekil 1' de gösterilmiştir.

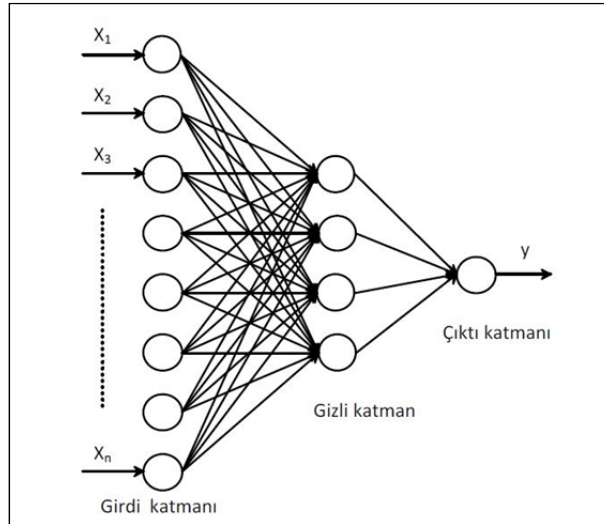

Şekil 2. YSA Çok Katmanlı Algılayıcı Modeli

Naive Bayes Sınıflandırıcı

Naive Bayes Sınıflandırıcı Örüntü tanıma problemine ilk bakışta oldukça kısıtlayıcı görülen bir önerme ile kullanılabilen olasılıklı bir yaklaşımdır. Bu önerme örüntü tanıma da kullanılacak her bir tanımlayıcı nitelik ya da parametrenin istatistik açıdan bağımsız olması gerekliliğidir. Her ne kadar bu önerme Naive Bayes Sınıflandırıcısının kullanım alanını kısıtlarsa da, genelde istatistik bağımsızlık koşulu esnetilerek kullanıldığında da daha karmaşık Yapay sinir ağları gibi metodlarla karşılaştırılabilir sonuçlar vermektedir. [7]

Naive bayes Algoritması, veri madenciliği, örüntü tanıma, makine öğrenmesi gibi disiplinler içinde yer alan bir sınıflandırma algoritmasıdır. Birbirinden bağımsız eğitim verileri ile algoritma eğitilir ardından yeni bir veri geldiğinde eğitilen verilere göre hangi gruba ait olduğu tahmin edilir.

BULGULAR

Çalışma kapsamında kalp hastalığı tespiti için MATLAB ortamındaki YSA ve Naive Bayes sınıflandırıcıları kullanılmış ve sınıflandırma yapılarak sonuçları karşılaştırılmıştır.

Çalışmada kullanılan veri setinde 120 adet kalp hastası ve 150 adet ise kalp hastası olmayan katılımcılara ait toplamda 270 adet veri kümesi vardır. 270 veri setinden alınan 140 (70 kalp hastası ve 70 kalp hastası olmayan) kişi ile bir ileri beslemeli yapay sinir ağı eğitimi yapıldı. Bu eğitilmiş ağımla ile kalan 130 veri üzerinden 60 veri alınarak başarılı bir şekilde test yapıldı. Teste tabi tutulan 60 kişiden 30'u kalp hastası diğer 30'u ise kalp hastası olmayan kişilerden seçilip test edilmiştir.

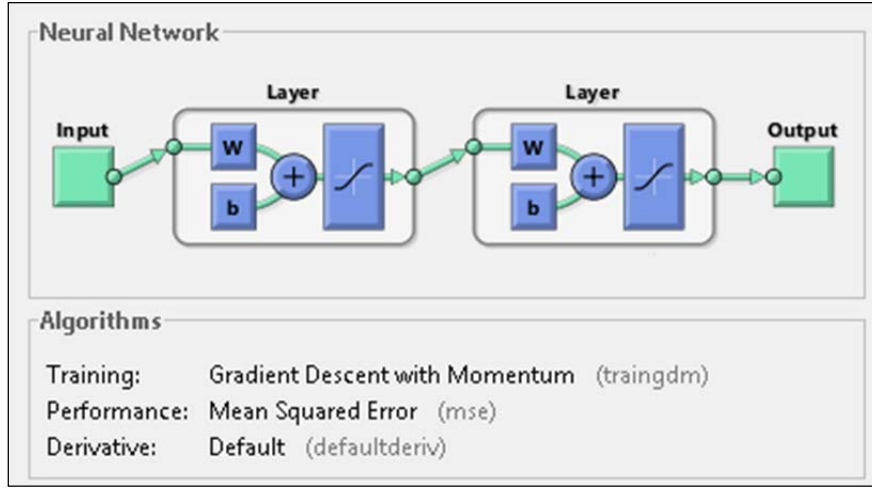

Şekil 3. Sistemde Kullanılan Matlab'te Tasarlanmış Yapay Sinir Ağ Modeli

Bu çalışmada MATLAB üzerinde şekil 1'de tasarlanmış ileri beslemeli yapay sinir ağı kullanılmıştır. Ağ için kullanılan aktivasyon fonksiyonu sigmoid, eğitim fonksiyonunda ise momentum geri yayılım algoritması kullanılmıştır.

Kullanılan ağımla performansı ROC (Receiver Operating Characteristic - Alıcı İşletim Karakteristiği) ve "Doğruluk Yüzdesi - Hata Yüzdesi" kriterlerine göre analizi yapılmıştır

ROC analizi için kullanılan parametreler;

TP: Olumlu sonucu olan ve olumlu öngörölmüş örnek sayısıdır.

FN: Olumlu sonucu olan ve olumsuz öngörölmüş örnek sayısıdır.

FP : Olumsuz sonucu olan ve olumlu öngörölmüş örnek sayısıdır.

FP : Olumsuz sonucu olan ve olumsuz öngörölmüş örnek sayısıdır.

Her iki sınıflandırma yöntemi için elde edilen doğruluk - hata yüzdeleri ve ROC analizleri Tablo 2 ve 3'te gösterilmiştir.

Tablo 2. Kullanılan İki farklı Yönteme Göre Performans Yüzdeleri

Yöntem	Doğruluk Yüzdesi	Hata Yüzdesi
YSA	90	10
Naive Bayes	81,667	18,333

Test edilen 60 verinin yapılan analiz sonucunda doğru tespit yüzdesi YSA kullanılarak yapılan sınıflandırmada %90 olurken, yanlış tespit yüzdesi ise %10 olarak hesaplanmıştır. Daha sonra aynı test verileri Naive Bayes algoritması ile test edilmiştir. Bayes teoremi ile %81,667 doğruluk yüzdesi, %18,333 hata yüzdesi tespit edilmiştir. Bu sonuçlar ışığında YSA ile yapılan testin performans sonuçlarının daha yüksek olduğu görölmüştür.

Tablo 3. Kullanılan İki farklı Yöntemin Test Sonuçları

Yöntem	TP	TN	FP	FN	Hatalı Sonuç
YSA	28	26	2	4	6
Naive Bayes	26	25	4	5	9

YSA ve Naive Bayes sınıflandırma yöntemleri sonucu elde edilen başarımla yüzdelere ilişkin sonuçları ise Şekil 4'deki grafik üzerinde gösterilmiş ve performans kıyaslamaları yapılmıştır.

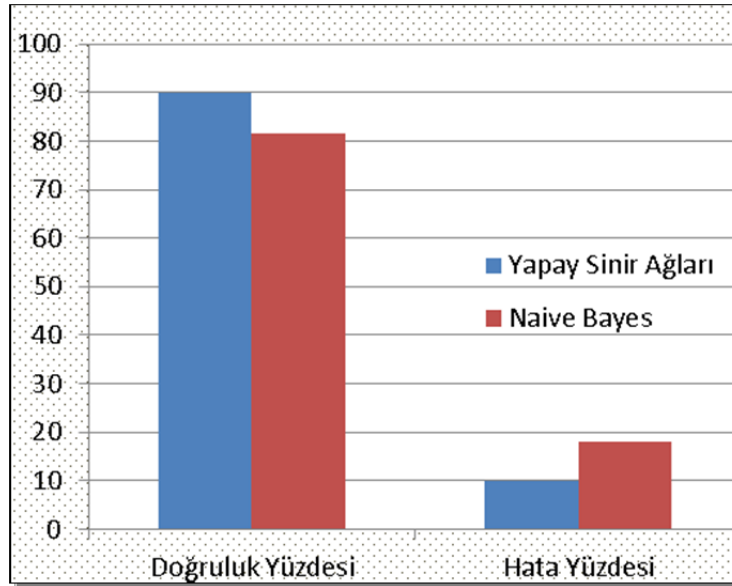

Şekil 4. YSA ve Naive Bayes Yöntemlerinin Doğruluk-Hata Yüzde Oranları

SONUÇ

Bu çalışmada, kalp hastalığı öznitelik vektörlerinin, geri yayımlı ileri beslemeli yapay sinir ağı (çok katmanlı algılayıcı) ve Naive Bayes sınıflandırıcı kullanılarak sınıflandırılmasına dayalı bir kalp hastalık teşhisi yapılmıştır. Kullanılan iki sınıflandırıcı performans açısından değerlendirilmiştir. Bu değerlendirme sonucunda YSA sınıflandırıcısından elde edilen sonuçların Naive Bayes yöntemine göre elde edilen sonuçlardan daha başarılı olduğu gözlemlenmiştir.

ÖNERİLER

Yapılan çalışmanın test performansını yükseltmek için daha farklı önleme teknikleri kullanılabilir ve farklı sınıflandırma yöntemleri ile bu çalışmanın başarımlarını değerlendirmesi yapılabilir.

KAYNAKLAR

- [1] Maton, Anthea (1993). Human Biology and Health. Englewood Cliffs, New Jersey: Prentice Hall. ISBN 0-13-981176-1.
- [2] Bridget B. Kelly; Institute of Medicine; Fuster, Valentin (2010). Promoting Cardiovascular Health in the Developing World: A Critical Challenge to Achieve Global Health. Washington, D.C: National Academies Press. ISBN 0-309-14774-3.
- [3] McGill HC, McMahan CA, Gidding SS (March 2008). "Preventing heart disease in the 21st century: implications of the Pathobiological Determinants of Atherosclerosis in Youth (PDAY) study". Circulation 117 (9): 1216–27. doi:10.1161/CIRCULATIONAHA.107.717033. PMID 18316498.
- [4] Çetin Elmas (2012), Yapay Zeka Uygulamaları, Yapay Sinir Ağları – Bulanık Mantık– Genetik Algoritma, Ankara: Seçkin Yayınevi ISBN 9789750216961
- [5] A. Frank ve A. Asuncion, UCI Machine Learning Repository, University of California, School of Information and Computer Science, 2010. [<http://archive.ics.uci.edu/ml>].
- [6] Ercan Öztemel (2006), Yapay Sinir Ağları, İstanbul: Papatya ISBN 9789756797396
- [7] Wiggins, M.; Saad, A.; Litt, B.; Vachtsevanos, G. (31 Aralık 2007). "Evolving a Bayesian classifier for ECG-based age classification in medical applications". Applied Soft Computing 8 (1): 599–608. doi:10.1016/j.asoc.2007.03.009.

LİSE ÖĞRENCİLERİNİN MATEMATİK DERSİNİ NİYE SEVMEDİKLERİ ÜZERİNE BİR ARAŞTIRMA

A STUDY ON WHY THE HIGH SCHOLL STUDENTS DON'T LIKE MATHEMATICS LESSON

Necati MERT

Yrd.Doç.Dr., Sakarya Üniversitesi, Mühendislik Fakültesi, İnşaat Mühendisliği Bölümü, SAKARYA
mert@sakarya.edu.tr

Ayşe MERT

Uzman Öğrt., Adapazarı Hacı Zehra Akkoç Kız Anadolu Lisesi, SAKARYA
mert@sakarya.edu.tr

ÖZET: Matematik dersi ülkemizde ilköğretimden orta öğretime(SBS) ve orta öğretimden üniversite eğitime(YGS ve LYS) geçişte gerçekleştirilen sınavlarda önemli bir belirleyici derstir. Buna karşın alınan eğitimlerin yeterliliği ve test teknikleri geliştirmek için ilave olarak alınan ek dersler(dershane eğitimi) bu dersteki başarıyı önemli olarak etkilemektedir. Bu çalışmada, Adapazarı Hacı Zehra Akkoç Kız Lisesinde okuyan 9. Sınıftan 201, 10. Sınıftan 140. 11. Sınıftan 150 ve 12. Sınıftan 143 olmak üzere toplam 634 öğrenci ile anket çalışması gerçekleştirilmiştir. Hazırlanan anket soruları ile öğrencilerin matematik dersine karşı çekinceleri, bu dersi sevmemelerinde etken olan unsurlar ve ailenin öğrencinin matematik dersini sevmesi üzerine katkısı araştırılmıştır.

Anahtar sözcükler: Matematik eğitimi, Anket, İstatistiksel değerlendirme, Temel istatistiksel Analiz, Lise

ABSTRACT: Among our country mathematics, secondary education (SBS) and secondary University education (YGS and LYS) is an important determinant in the exams held in the transition. By contrast, received training in addition to develop and test the adequacy of techniques taken from additional courses (classroom training) this tutorial as a significant success. In this study, Adapazarı Hacı Zehra Akkoç Girl's Anatolian School recited by 9. Class 201, 10. Class 140. 11. The class 150 and 12. A total of 143 from 634 student survey was carried out. Students with the math lesson reservations against the prepared the survey questions, this class is the unlike factor in the contribution of the student to love math features and family was investigated.

Key words: Mathematic Education, Survey, Statistical Evaluation, Basic Statistical Analysis , High School

GİRİŞ

Matematik dersi ülkemizde ilköğretimden orta öğretime(SBS) ve orta öğretimden üniversite eğitime(YGS ve LYS) geçişte gerçekleştirilen sınavlarda önemli bir belirleyici derstir. Buna karşın alınan eğitimlerin yeterliliği ve test teknikleri geliştirmek için ilave olarak alınan ek dersler(dershane eğitimi) bu dersteki başarıyı önemli olarak etkilemektedir. Son günlerde gerek bu geçiş sınavlarında yapılan yeni düzenlemeler gerekse yenilenen ve sürekli değişen ders müfredatları eğitim konusunda birçok belirsizlikler ortaya çıkarmaktadır.

Bu çalışmada, Adapazarı Hacı Zehra Akkoç Kız Anadolu Lisesinde okuyan 9. Sınıftan 201, 10. Sınıftan 140. 11. Sınıftan 150 ve 12. Sınıftan 143 olmak üzere toplam 634 öğrenci ile anket çalışması gerçekleştirilmiştir(Ek1). Hazırlanan anket soruları ile öğrencilerin matematik dersine karşı çekinceleri, bu dersi sevmemelerinde etken olan unsurlar ve ailenin öğrencinin matematik dersini sevmesi üzerine katkısı araştırılmıştır.

Matematik dersinin öğretilmesi ve öğrenilebilmesi üzerine birçok bilimsel araştırma çalışmaları gerçekleştirilmiştir. Bunlarda farklı araştırma ve analiz teknikleri kullanılarak matematik dersi üzerine öğrencilerin kaygı, bakış açısı ve algılamaları ile ilgili çalışmalar yapılmıştır. Günümüzde

N. İzzet KURBANOĞLU ve Mithat TAKUNYACI[1] tarafından gerçekleştirilen çalışmada, lise öğrencilerinin matematik dersine yönelik kaygı, tutum ve öz-yeterlik inançlarının, cinsiyet, okul türü ve sınıf düzeyi açısından anlamlı bir fark oluşturup oluşturmadığını incelemektedir. Çalışmada veri toplama aracı olarak, Matematik Tutum Ölçeği, Matematik Kaygısı Değerlendirme Ölçeği ve Güdülenme Ölçeği kullanılmıştır.

Kemal ÖZGEN ve Recep BİNDAK[2] tarafından gerçekleştirilen çalışmada, lise öğrencilerinin (9., 10., 11. ve 12. sınıf) matematik okuryazarlığı öz yeterlik inançlarını belirleme-yi ve öğrencilerin öz yeterlik inançlarının cinsiyet, sınıf, okul türü, matematik dersi başarı puanı, anne- aba eğitim durumu ve matematik dersine verilen önem değişkenlerine göre incelemeyi amaçlamaktadır.

Özge ARICI[3] , tarafından gerçekleştirilen çalışmada, öğretmen görüşlerine göre öğrencilerin matematik dersine yönelik tutumlarını etkileyen faktörler ikili karşılaştırma yöntemiyle ölçeklenmiştir. Araştırmanın verileri 2011-2012 eğitim-öğretim yılında Türkiye'nin çeşitli yerlerinde görev yapan 243 öğretmenden toplanmıştır. Araştırmada, öğretmen görüşlerine göre öğrencilerin matematik dersine yönelik tutumlarını en çok etkileyen faktörün öğretmenin dersini öğrenciye sevdirebilmesi olduğu bulgusuna ulaşılmıştır.

Arif DANE[4] v.d tarafından gerçekleştirilen çalışmada, lise öğrencilerinin matematik başarılarını olumsuz yönde etkileyen faktörleri incelemek ve alınabilecek önlemler için bazı öneriler sunmaktır. Bu amacı gerçekleştirmek üzere; veri toplama aracı olarak araştırmacılar tarafından hazırlanan bir anket formu kullanılmıştır. Bu çalışmanın örneklemini 2002-2003 öğretim yılında Sivas ilinde rasgele (Random) seçilen 6 farklı liseye devam eden, 152 kız ve 134 erkek olmak üzere toplam 286 öğrenci oluşturmuştur.

Dr. Murat PEKER[5] v.d tarafından gerçekleştirilen çalışmada, resmi genel liselerin ikinci sınıf öğrencilerinin matematiğe yönelik tutumlarını, matematik başarılarını ve öğrencilerin tutum puanları ile başarı puanları arasındaki ilişkiyi incelemektir. Öğrencilerin matematiğe yönelik tutumları Aşkar (1986) tarafından geliştirilen matematik tutum ölçeği ile belirlenmiştir. Öğrencilerin matematik başarıları yazar tarafından hazırlanan matematik başarı testi ile belirlenmiştir.

YÖNTEM

Bu çalışmada, öğrencilerin matematik dersini neden sevmedikleri üzerine bir araştırma gerçekleştirilmiştir. Öğrencilerin matematik dersine karşı olan tutumlarını belirlemek ve buna etken olan sebepleri araştırmak üzere anket soruları hazırlanmıştır(Ek1). Hazırlanan bu anket sorularını, 9. Sınıftan 201, 10. Sınıftan 140, 11. Sınıftan 150 ve 12. Sınıftan 143 olmak üzere toplam 634 öğrenci cevaplamıştır. Verilen cevaplar üzerine yapılan temel istatistiksel analiz sonucunda elde edilen değerler grafikler halinde sunulmuştur. Sunumlarda sınıf ve şube bazında sonuçlara yer verilmiştir.

Anket Çalışması

Anket soruları hazırlanırken(Ek), Lise öğrencilerinin her sınıftan matematik dersine karşı tutumlarını belirlemek ve bu dersi sevmemelerinde etken olan sebepleri araştırmak hedeflenmiştir. Öğrencilerin sorulan sorulara 5 farklı kademede not vermesi istenmiştir.

ANALİZ VE DEĞERLENDİRMELER

Öğrenciler tarafından Matematik dersinin sevilmemesinde bu dersin zor olduğu düşüncesi önemli etkindir. Bu amaçla hazırlanan anket çalışmasının ilk sorusunda "Matematik dersi gördüğüm derslerin içerisinde bana göre en zor derstir" denmiştir. Katılan öğrencilerin Katılıyorum ve Kesinlikle Katılıyorum diyerek değerlendirdiği ilk soruda 9. Sınıf öğrencilerin ortalama % 51,93'ü dersi çok zor olarak görmektedir.

Tablo1. 9. Sınıf öğrencilerine göre dersin zor olduğuna dair değerlendirme

Sınıflar	9A	9B	9C	9D	9E	9F	9G	9H
Katılıyorum	4	8	3	6	6	4	2	0
Kesinlikle Katılıyorum	12	9	4	13	9	7	12	7
Toplam	32	32	18	31	26	30	19	15
Yüzdeler	53,33	53,13	38,89	61,29	57,69	36,67	73,68	46,67

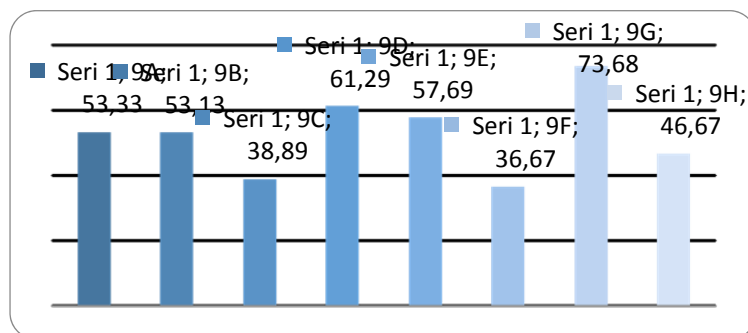

Şekil 1. 9. Sınıfların zorluk durumu değerlendirme grafiği

9. Sınıf sonunda öğrenciler Sayısal, Sözel ve Eşit Ağırlık sınıfları olarak ayrılmaktadır. Anket sonucu incelendiğinde sadece sayısal sınıf olan 10 A'nın matematik dersini çok zor görmediği, buna karşılık sözel ve eşit ağırlık öğrencileri ortalama %71,34 oranında çok zor bir ders olarak görmektedir.

Tablo 2. 10. Sınıf öğrencilerine göre dersin zor olduğuna dair değerlendirmesi

Sınıflar	10A	10B	10C	10D	10E
Yüzdeler	8	78,57	72,41	50	84,38

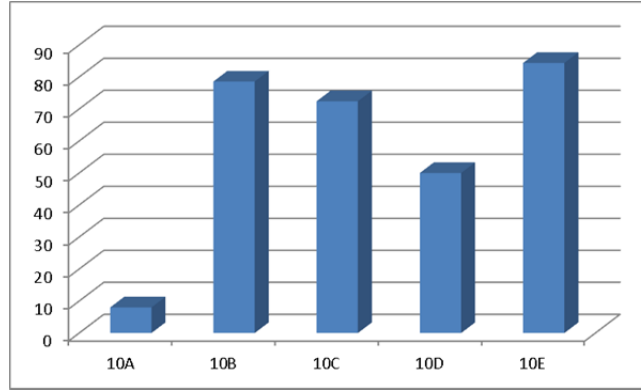

Şekil 2. 10. Sınıfların zorluk durumu değerlendirme grafiği

Öğrencilerin üniversite tercihleri konusunda odaklandığı ve öğrenimleri ile ilgili gelecek hesapları yaptığı 11. Sınıfta matematik dersi özellikle sayısal sınıflarında(11A-B) temel ders olmakta ve korku ciddi ölçüde azaldığı görülmektedir. Buna karşın eşit ağırlık ve sözel bölüm sınıflarında(11C-D-E-F-G) korku %70 oranında kendini göstermiştir

Tablo 3. 11. Sınıf öğrencilerine göre dersin zor olduğuna dair değerlendirmesi

Sınıflar	11A	11B	11C	11D	11E	11F	11G
Yüzdeler	0	0	55,35	59,09	68	70	70,59

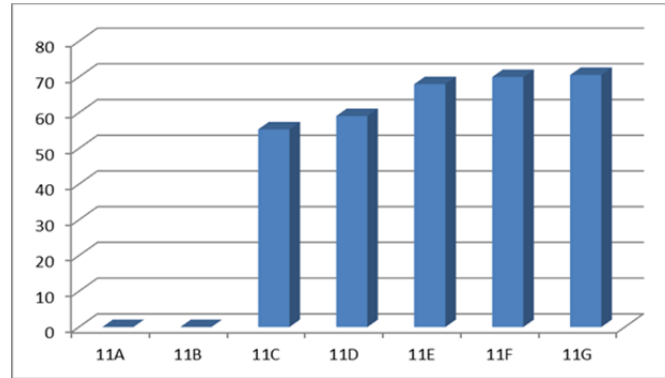

Şekil 3. 11. Sınıfların zorluk durumu değerlendirme grafiği

Okul eğitimlerinin son halkası olan üniversite eğitime giriş için oldukça yoğunlaşan son sınıf öğrencilerinde aldıkları eğitim ve öz güvenlerinin artmasıyla bu korku oldukça azalmış görünmektedir. Buna karşın özellikle sözel öğrencilerinde matematik dersi % 84,89 oranında zor olarak kabul edilmiştir.

Tablo 4 12. Sınıf öğrencilerine göre dersin zor olduğuna dair değerlendirmesi

Sınıflar	12A	12B	12C	12D	12E	12F
Yüzdeler	10,53	0	35,72	51,72	50	84,89

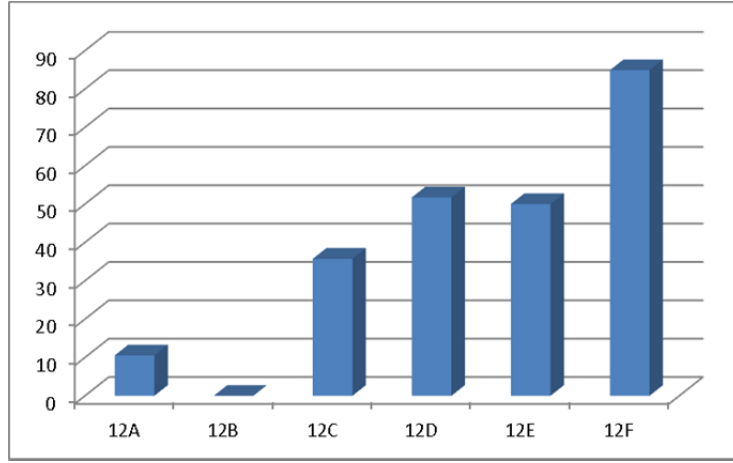

Şekil 4. 11. Sınıfların zorluk durumu değerlendirme grafiği

10, 11 ve 12. Sınıftaki sayısal sınıflar çıkarıldığında kalan eşit ağırlık ve sözel öğrencilerine göre matematik dersinin zorluğuna dair düşünceleri aşağıdaki grafiklerde açıkça görülmüştür.

Tablo 5. Sınıflar bazında bütün öğrencilerin matematik dersi zorluk değerlendirmesi

Sınıflar	9. Sınıflar	10. Sınıflar	11. Sınıflar	12. Sınıflar
Yüzdelerik	51,93	71,64	64,41	55,58

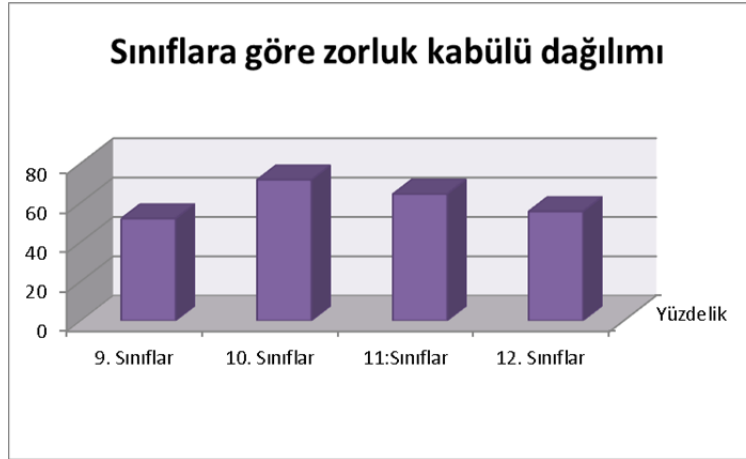

Şekil 5. Sınıflar bazında zorluk kabulünün dağılımı

Öğrencilerin dersi sevmesinde öğretmenlerin dersi anlatma şeklinin etkili olup olmadığını araştırmak üzere anket çalışmamızda sorulan yedinci soruda “Öğretmenin dersi anlatım şekli konuları kolay kavramamızda önemli etkindir.” denmiştir.

Tablo 6. 9. Sınıflar için öğretmenin dersi anlatım şeklinin etkisi değerlendirmesi

Sınıflar	9A	9B	9C	9D	9E	9F	9G	9H
Katılıyorum	5	8	3	6	6	3	0	3
Kesinlikle Katılıyorum	25	22	12	19	18	27	16	11
Toplam	30	32	18	31	26	30	19	15
Yüzdelerik	100	93,75	83,33	80,65	92,31	100	84,21	93,33

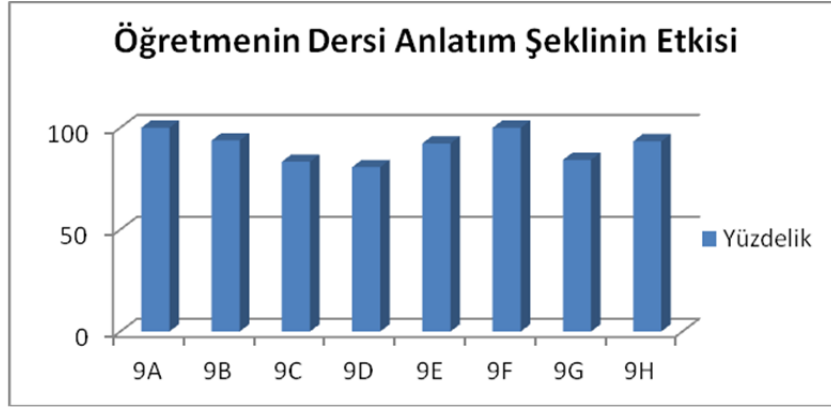

Şekil 6. 9. Sınıf öğrencilerinin öğretmenin dersi anlatım şeklinin etkisi üzerine değerlendirmesi

Öğrencilerin okulda gördüğü matematik dersiyile ilgili olarak gördüğü eksiklikleri aileleri yardımıyla çözebilme yeteneklerini ölçmek üzere ” *Dersteki eksiklerimizin giderilmesinde anne-babamızın katkısı olmamaktadır.*” şeklinde altıncı soru yöneltildi. Sorulara verilen cevaplar analiz edildiğinde kesinlikle katılmıyorum ve katılmıyorum cevapları esas alınarak yapılan analizde ailelerin bu konuda pek desteklerinin olmadığı anlaşılmaktadır.

Tablo 7. 9. Sınıf öğrencilerinin dersteki eksikliklerin giderilmesinde ailelerin katkısı üzerine değerlendirme

Sınıflar	9A	9B	9C	9D	9E	9F	9G	9H
Kesinlikle Katılmıyorum	17	9	7	7	10	13	7	3
Katılmıyorum	5	13	2	5	6	4	0	1
Toplam	30	32	18	31	26	30	19	15
Yüzelik	73,33	68,75	50	38,71	61,54	56,67	36,84	26,67

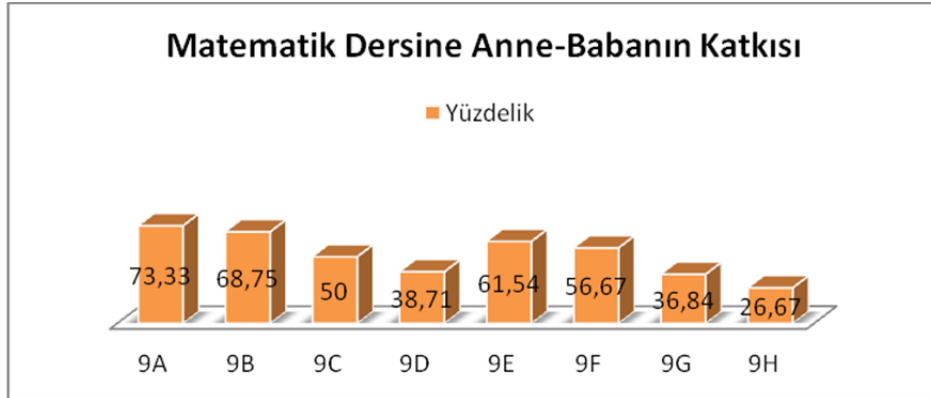

Şekil 7. 9. Sınıf öğrencilerine anne-babaların matematik dersine katkısı

Üniversite giriş sınavına hazırlığın son dönemeci olan lise son sınıfa gelindiğinde öğrencilerin okul dışında dersane takviyesi de aldığından ailesinin katkısını genelde görememektedir. Ya da anne-babalarının yerine dersane veya okul öğretmenlerinden destek almaktadır.

Tablo 8. 12. Sınıf öğrencilerin matematik dersine anne-babalarının katkısı

Sınıflar	12A	12B	12C	12D	12E	12F
Kesinlikle Katılmıyorum	9	4	7	13	12	6
Katılmıyorum	4	2	13	5	7	5
Toplam	19	12	28	29	28	27
Yüzelik	68,42	50	71,42	62,07	67,86	40,74

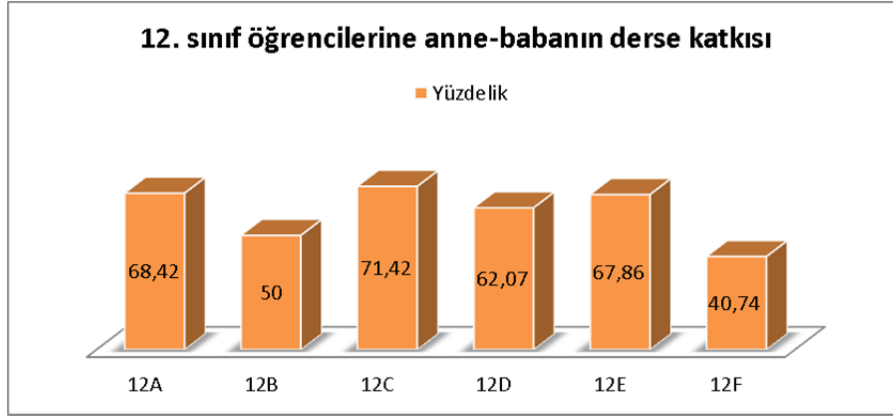

Şekil 8. 12. Sınıf öğrencilerinde matematik dersine anne-babanın katkısı analizi

SONUÇ

Hacı Zehra Akkoç Kız Anadolu Lisesi, 9. Sınıf itibarıyla SBS sınav sonuçlarına göre öğrenci kaydı almaktadır. Okul puanı incelendiğinde emsallerine göre bir miktar düşük puanlı öğrenciler yerleştirilmiştir. Ancak okuldaki yetkin ve başarılı öğretmen kadrolarının verdiği düzeyli eğitimle seviyeleri yükseltilmeye çalışılmaktadır. Yapılan anket çalışmaları göstermiştir ki;

1. Öğrencilerin büyük bir bölümü az sayıda matematik sorusu cevapladığından ve matematik alt yapılarındaki yetersizliklerden dolayı matematik dersi çok zor bir ders olarak nitelendirilmektedir.
2. Öğrencilerin “Öğretmenin dersi anlatım şekli konuları kolay kavramamızda önemli etkindir.” sorusu için ankete verdiği sonuçlar incelendiğinde 9. Sınıfların %90,95 ‘inin öğrencilerin matematik dersini sevmesinde öğretmenin dersi anlatım şeklinin önemli olduğu görüşünü belirtmiştir.
3. Anne ve babalarının eğitim seviyelerine bağlı olarak değişse de öğrencilerin büyük bir bölümü matematik dersini öğrenmede anne ve babalarından destek görememektedir
4. Ankete katılan öğrencilerin %90’ının üzerine büyük bir bölümü tüm sınıflarda ve şubelerde dahil olmak üzere, matematik dersini sevmemelerinde ilk ve orta öğretimdeki temel altyapı eksikliklerinin önemli rol oynadığını belirtmişlerdir.
5. Öğrencilerin %80’inin üzerinde bir kısım derslerde yeteri kadar örnek çözülmemesinin dersi öğrenmeyi zorlaştırdığı görüşünü bildirmiştir.
6. Öğrencilerin %60’sinin üzerinde bir kısmı iş hayatında matematiğin benim için bir önemi olacağına inanmaktadır. Özellikle sayısal bölüm tercih eden öğrenciler matematiğin iş hayatlarının vazgeçilmez bir parçası olduğunu düşünmektedir.
7. Ankete katılan öğrencilerin %85’i kadar büyük çoğunluğu matematik dersinde gördüğü konuların çokluğu ve yoğunluğundan yakınmakta, bu yoğunluğun dersi kolay kavramalarını güçleştirdiğini düşünmektedirler.
8. Öğrencilerin büyük bir kısmının matematik dersini anlama ve sevmelerinde destek olduklarını, bu amaçla gerek okulda gerekse dersanelerde açılan kurslara yönlendirilerek başarı derecesini arttırmaya çalıştıklarını bildirmektedir.
9. Özellikle sözel ve eşit ağırlık bölümü seçmiş öğrencilerin %50 sine yakın bir kısmı zor bir problemle uğraşip onu çözmeye çalışmak yerini birinin çözülmüş halini kendisine vermesini tercih etmektedir. Bu durum öğrencide matematik üzerine yoğunlaşma ve çabalamayı engellemekte öğrencileri kolaycılığa alıştırmaktadır. Oysa öğrencilerin yardımcı kaynak kitaplardan ya da konuyu kendisinden daha iyi kavradığını anladığı arkadaşlarıyla yardımlaşarak çözmesi ona önemli kazançlar sağlayacaktır.

KAYNAKLAR

- [1]. N. İzzet Kurbanoğlu, Mithat Takunyacı, “Lise öğrencilerinin matematik dersine yönelik kaygı, tutum ve öz-yeterlik inançlarının cinsiyet, okul türü ve sınıf düzeyi açısından incelenmesi”, Uluslararası İnsan Bilimleri dergisi, Cilt:9, Sayı:1, 2012
- [2]. Kemal Özgen, Recep BİNDAK, “Lise Öğrencilerinin Matematik Okuryazarlığına Yönelik Öz-Yeterlik İnançlarının Belirlenmesi”, Kuram ve Uygulamada Eğitim Bilimleri • Educational Sciences: Theory & Practice - 11(2) • Bahar/Spring • 1073-1089

- [3]. Özge ARICI, “Öğretmen Görüşlerine Göre Öğrencilerin Matematik Dersine Yönelik Tutumlarını Etkileyen Faktörlerin Ölçeklenmesi Çalışması”, Ege Eğitim Dergisi 2013 (14) 2: 25–40
- [4]. Arif DANE, Mustafa KUDU ve Nihat BALKI, “Lise öğrencilerinin algılarına göre, matematik başarısını olumsuz yönde etkileyen faktörler”, EÜFBED - Fen Bilimleri Enstitüsü Dergisi Cilt-Sayı: 2-1 Yıl: 2009
- [5]. Murat PEKER, Şeref MİRASYEDİOĞLU, “ Lise 2. Sınıf öğrencilerinin matematik dersine yönelik tutumları ve başarıları arasında ilişki”, Pamukkale Üniversitesi Eğitim Fakültesi Dergisi Yıl:2003 (2) Sayı:14, sayfa:157-166
- [6]. Alkan, H., Büyükova Güzel E. ve Nuket Elçi, A. “Öğrencilerin Matematiğe yönelik tutumlarında Matematik öğretmenlerinin üstlendiği rollerin belirlenmesi. XIII. Ulusal Eğitim Bilimleri Kurultayı, 6-9 Temmuz 2004 İnönü Üniversitesi, Eğitim Fakültesi, Malatya, 2004.
- [7]. Tekin, H. “Eğitimde ölçme ve değerlendirme” (18. bs). Ankara: Yargı Yayınevi. (2007)

Ek Anket Soruları

Tablo1. MATEMATİK DERSİ NEDEN SEVİLMEZ? KONULU ARAŞTIRMA PROJESİ ANKET SORULARI

BÖLÜM 1. KİŞİSEL BİLGİLER

Sınıfınız:	<input type="checkbox"/> 9. Sınıf	<input type="checkbox"/> 10. Sınıf	<input type="checkbox"/> 11. Sınıf	<input type="checkbox"/> 12. Sınıf
Üniversite sınavına hangi alanda girmeyi planlıyorsunuz?	<input type="checkbox"/> Sözel	<input type="checkbox"/> Eşit Ağırlık	<input type="checkbox"/> Sayısal	
Hangi Mesleği Düşünüyorsunuz?	:.....			
Kendinizi matematik dersinde nasıl görürsünüz?	<input type="checkbox"/> Başarısız	<input type="checkbox"/> Orta	<input type="checkbox"/> Başarılı	

BÖLÜM 2. BU BÖLÜMDE ÖĞRENCİLERİMİZİN MATEMATİK DERSİNİ NEDEN SEVMEDİKLERİ KONUSUNDA TEMEL NEDENLER ARAŞTIRILACAKTIR.

Yaptığımız ANKET ile ilgili değerlendirmeleri aşağıdaki derecelendirme kriterlerine göre yapınız. 1: Kesinlikle Katılmıyorum 2: Katılmıyorum , 3: Kararsızım, 4:Katılıyorum, 5: Kesinlikle Katılıyorum	PUAN (1-5)
1. Matematik dersi gördüğüm derslerin içerisinde bana göre en zor derstir.	
2. Dersi sevmememde ilkokul ve ortaokulda yeterli alt yapımın oluşmaması önemli bir etkidir.	
3. İşlem yeteneğimin tam gelişmemesi dersi sevmememde etkilidir.	
4. İşlenen konuların çokluğu ve yoğunluğu dersi kolay öğrenmemimizi engellemektedir.	
5. Derste yeteri kadar örnekler çözülmemesi konuları daha iyi kavramamızı engellemektedir.	
6. Dersteeki eksiklerimizin giderilmesinde anne-babamızın katkısı olmamaktadır.	
7. Öğretmenin dersi anlatım şekli konuları kolay kavramamızda önemli etkidir.	
8. Liseden mezun olduktan sonraki yaşamımda matematiğe ihtiyacım olmayacağını düşünüyorum.	
9. İş hayatımda matematiğin benim için bir önemi olmayacağına inanıyorum.	
10. Matematik ilerideki güncel yaşamımda çok nadir olarak kullanacağım bir alandır.	
11. Ailem matematik dersinde başarılı olabilmem için beni cesaretlendirir.	
12. Matematik problemlerini çözemediğimde kendime olan özgüvenimi kaybediyorum.	
13. Çözemediğim problemlerle ilgili öğretmenlerimden destek almak beni heveslendirir.	
14. Zor bir matematik sorusu çözmek yerine, birinin bana sorunun çözümünü vermesini beklerim.	
15. Matematik dersinde katılımcı olup anlamadığım soruları anında sormak öğrenmemi kolaylaştırır.	

KNOWLEDGE OF CURRICULUM OBJECTIVES AND POSSESSION OF THE SUBJECT – NECESSITY FOR ALBANIAN LANGUAGE ACQUISITION FROM STUDENTS

Aimir OSMANI

ABSTRACT: This paper addresses the importance of theoretical knowledge of the subject objectives of the Albanian language in its practical application within the 9 - year-old school curriculums. Albanian schools after '90, was faced with a new reality and didactic concepts that should be included in the teaching process. So as curriculums , textbooks also began to be developed on the basis of a new concept, having undergone changes both in content and in structure, guided by the experience of our school with a history more than a century, but in especially the new developments of the Albanian society. In these circumstances, the work should focus on two aspects: firstly; the work of teachers, his preparation and ability to teach this subject more clearly, to achieve the main objective of communication, as well as the preparation of students for the learning Albanian language, to see the advantage that it helps to throw in society. Two goals are: To achieve communication skills, to help the whole cycle of communication and given and collated knowledge to Albanian language and its system. These lines are carried through listening, speaking, reading and writing. Knowledge of the curriculum by the teacher is a necessity, since there are clearly marked by class objectives that must arrive. Conception of a class in accordance with the standards, based on the most successful achievements related the scientific and didactic, using a contemporary literature, but not excluding threesome teacher - student - family, will create all the chances of achieving a compelling linguistic background and accepted for Albanian society today. Therefore the main task before the school remains active and practical possession of the Albanian language.

Keywords: teaching, curriculum, objectives, Albanian language, acquisition

6-7-8. SINIF MATEMATİK DERSİ ÖĞRETİM PROGRAMINDA YER ALAN ARA DİSİPLİNLERE YÖNELİK ÖĞRETMEN GÖRÜŞLERİ

THE OPINIONS OF SIXTH, SEVENTH AND EIGHTH GRADE MATHS TEACHERS ABOUT CROSS CURRICULUM DISCIPLINES

Şule AKYOL
Mehmet Akif Ersoy Üniversitesi
sakyol@mehmetakif.edu.tr

Esed YAĞCI
Hacettepe Üniversitesi
esed@hacettepe.edu.tr

ÖZET: Bu çalışma 6-7-8. sınıf matematik dersi öğretim programında yer alan ara disiplinlere yönelik öğretmen görüşlerini belirlemek amacıyla yapılmıştır. Araştırmanın çalışma grubunu Burdur ili merkez ve ilçelerindeki devlet ve özel okullarda görev yapan 91 matematik öğretmeni oluşturmuştur. Öğretmenlere, araştırmacı tarafından geliştirilen ve uzman görüşleriyle nihai şeklini alan anket uygulanmıştır. Verilerin analizinde aritmetik ortalama, standart sapma, Mann Whitney U- Testi ve Kruskal Wallis H-Testi kullanılmıştır. Öğretmen görüşlerinde anketin bazı maddelerine verilen cevaplar arasında cinsiyete, kıdeme ve mezuniyet durumuna göre .05 düzeyinde anlamlı farklar bulunmuştur. Öğretmenlerin çoğunluğu, ara disiplinlerin matematiği diğer derslerle ve yaşamla ilişkilendirmede öğrencilere yardımcı olduğunu düşünmektedir. Öğretmenler ara disiplinler konusunda bilgilendirmeye ihtiyaç duymaktadır. Öğretmenler, ara disiplin kazanımlarının kazandırılabilir nitelikte olduğunu düşünmektedir

Anahtar sözcükler: ara disiplinler, ara disiplin kazanımları, 6-7-8. sınıf matematik dersi öğretim programı

ABSTRACT: This study was conducted to take teachers opinions about cross curriculum approach which taken part in 6, 7, 8. grade maths curriculum. The group of study is formed by 91 maths teachers who work in the nation and private elementary schools which is placed in Burdur. The data was gathered from survey, is developed by the researcher and taken last form by the expert's opinions. Mean, standard deviation and Mann Whitney U-Test, Kruskal Wallis H- Test were used. It was found significant difference at .05 level in teacher's opinions among the some answers of survey according to gender, seniority and graduation situation. Most of the teachers thought that cross curriculum disciplines are assisting students about overarching maths with life and other disciplines. Teachers need information. Teachers thought that the attainments of cross curriculum disciplines are attainable qualification.

Key words: cross curriculum disciplines, attainments of cross curriculum, 6, 7, 8. grade maths curriculum.

GİRİŞ

Ara disiplinler; ilköğretim matematik dersi öğretim programı ile ilişkilendirilmiş, bütün programlarda yer alan ve ortak olarak kazandırılması gereken özelliklerdir (Akyol, 2011).

Matematik programına ara disiplinler yerleştirilerek kazanımlar zenginleştirilmiş, öğrencilerin korkulu rüyası olan matematik dersi yaşamla ve bazı belirlenen alanlarla ilişkilendirilerek tek bir disiplin olarak sıkışıp kalması engellenmek istenmiştir (Akyol, 2011). Matematik öğretim programının kazanımlarıyla ilişkilendirilen 8 ara disiplin bulunmaktadır. Bunlar; Sağlık Kültürü, İnsan Hakları ve Vatandaşlık, Girişimcilik, Kariyer Bilinci Geliştirme, Rehberlik ve Psikolojik Danışma, Spor Kültürü ve Olimpik Eğitim, Afetten Korunma ve Güvenli Yaşam, Özel Eğitimdir. MEB, matematik dersi 6-8. sınıf öğretim programı ve kılavuzunda 'ilişkilendirme önemsenmelidir' başlığı altında ara disiplinlerin programa yerleştirilmesinin sebebini şu şekilde ifade etmiştir: "Matematik bilgilerinin, hem gerçek hayatta hem de diğer derslerde öğrenilenlerle ilişkilendirilmesine önem verilmelidir. Günlük yaşamda, birçok durumda çeşitli zorluk derecelerinde matematiğe ait problemler karşımıza çıkmakta ve matematik pek çok meslek dalında kullanılmaktadır. Bu nedenle problemler, öğrencilerin matematiğin günlük hayattaki kullanımını açık biçimde görmelerine yardımcı olacak şekilde seçilmelidir. Öğrenciler matematiğin diğer derslerde de kullanılabildiğini gördüklerinde, kazanımları daha anlamlı olacaktır. Bu amaçla matematik dersi belli başlı ara disiplinlerle ilişkilendirilmiştir (MEB, 2009)." MEB aynı yerde, etkinlikler planlanırken ve yürütülürken alt öğrenme alanlarındaki kazanımlar ile ara disiplinlerin kazanımlarının aynı anda edinilmesine dikkat edilmesi gerektiğini belirtmiştir.

2005'te uygulamaya koyulan yeni ilköğretim programlarının gerek ders içi, gerekse diğer derslerle ve ara disiplinlerle ilişkilendirmeler boyutlarında önceki programlara göre önemli ölçüde değişim gösterdiği görülmüştür. Demirel ve Coşkun (2009), bu değişimin programın uygulayıcıları olan öğretmenler tarafından ne derece benimsendiği ve uygulamaya konduğu konusunu incelenmesi gereken bir durum olarak görmüştür.

Ara disiplinler, program hazırlama sürecinde göz önünde bulundurulana ana disiplinlerle açık ve kapsayıcı biçimde örtüşen diğer disiplinler olarak tanımlanmıştır (ERG, 2005, s. 118).

Ara disiplin temaları; bilginin belirli bir alana veya disipline hapsedilmemesini, aralarında ilişkilendirilmesini gerektirmektedir (Print, 1993; Dolz ve diğerleri, 1994; Akt. Naval ve diğerleri, 2003). Örneğin İspanya'da ara disiplinler; vatandaş ve değer eğitimi, barış eğitimi, sağlık eğitimi, cinsiyetler arasında fırsatlar eşitliği eğitimi, çevre eğitimi, cinsiyet eğitimi, tüketici eğitimi ve trafik eğitimini içermektedir (MEC 1992; Akt. Naval ve diğerleri, 2003).

Ara disiplin temaları, sosyal taleplere veya konulara cevap vermektedir. Okulun sosyal içeriğinde rastlanılan sosyal ve insan problemlerini göstermektedir; böylece okulun sosyalleştirme fonksiyonunu güçlendirmektedir. Ek olarak ara disiplin temaları, ülke insanlarının günlük yaşamına değindikçe, kaçınılmaz bir şekilde daha özgür, barışçıl ve doğal çevre konusunda daha sorumlu insanlarla dolu toplumun yapısını inşa edecektir (MEC 1992a; Akt. Naval ve diğerleri, 2003). Özet olarak ara disiplin temaları; toplumun ve öğrencilerin hayati tecrübelerinden ortaya çıkmaktadır ve çevreyle ilgili sosyal taleplere cevap vermektedir, günlük hayattaki zıtlıkları içeren kritik davranışları teşvik etmektedir; programın gizli (örtük) kısmına ait açıklığı içermektedir, bireylerin gelişimini tamamlamaya katkıda bulunmaktadır (Naval ve diğerleri, 2003). Ara disiplinler sayesinde öğrenciler; 1) Başkalarının ve kendilerinin sorumluluğunu ve değerini öğrenmektedir. 2) Toplumdaki insanların dayanışmasını anlamaktadır. 3) Fiziksel, ruhsal, sosyal potansiyellerini başarılarak; kendini bilme ve özsaygılarını geliştirmektedir. 4) Yetişkin bireyler olarak; anlayış ve bilgilerini ve diğer güçlü yönlerini ve sınırlarını, kişisel özelliğini, ilgilerini, yeteneklerini, becerilerini, potansiyelini, değerlerini, motivasyon ve ihtiyaçlarını geliştirmektedir (DENI, 2008).

Yağcı, Demirel ve Tatar (2009), ara disiplinlerle bütünleştirilmesi amacıyla programlarda yapılan düzenlemelerin olumlu bir girişim olduğunu, ancak programların asıl uygulayıcıları olan öğretmenlerin yaşadığı sorunların dikkate alınarak gerekli düzenlemelerin yapılması gerekmekte olduğunu vurgulamıştır. Bu amaçla bu araştırmada matematik programında yer alan ara disiplinlere ilişkin öğretmen görüşlerini belirlemek ve elde edilen bulgular ışığında yorum yapmak ve öneriler sunmak hedeflenmiştir. Araştırma, matematik öğretmenlerinin ara disiplinlerden haberdar olma düzeyini ortaya çıkarması açısından önemlidir.

Çalışmada şu alt problemlere yanıt aranmıştır: 1) 6-7- 8. sınıflar matematik dersi öğretim programında yer alan ara disiplinlere yönelik öğretmen görüşleri nelerdir? 2) Cinsiyete göre öğretmen görüşleri arasında anlamlı bir fark var mıdır? 3) Kıdeme göre öğretmen görüşleri arasında anlamlı bir fark var mıdır? 4) Mezuniyet durumuna göre öğretmen görüşleri arasında anlamlı bir fark var mıdır?

YÖNTEM

Araştırmanın Modeli

Bu araştırmada geçmişte ya da halen var olan bir durumu var olduğu şekliyle betimlemeyi amaçlayan araştırma yaklaşımlarından biri olan tarama modeli kullanılmıştır. Bu modelde araştırmaya konu olan birey ya da nesne kendi koşulları içinde ve olduğu gibi tanımlanmaya çalışılır (Karasar, 2009, s.77).

Çalışma Grubu

Araştırmanın çalışma gurubunu Burdur ili merkez ve ilçelerindeki devlet ve özel okullarda görev yapan 91 matematik öğretmeni oluşturmuştur.

Matematik öğretmenlerinin 54'ü (% 59) kadın, 37'si (% 41) erkektir. Öğretmenlerin 35'i (% 38,5) 1-5 yıl, 41'i (% 45) 6-10 yıl, 10'u (% 11) 11-15 yıl, 1'i (% 1) 16-19 yıl ve 4'ü (% 4) 20 yıl ve üstü kıdeme sahiptir. Öğretmenlerin 5'i (% 5,5) eğitim enstitüsü, 71'i (% 78) eğitim fakültesi ilköğretim matematik öğretmenliği ve 15'i (% 16,5) diğer (fen edebiyat matematik bölümü, matematik öğretmenliği, yüksek lisans...) okul mezunudur.

Veri toplama araçları

Öğretmenlere, araştırmacı tarafından geliştirilen ve uzman görüşleriyle nihai şeklini alan anket uygulanmıştır. Anketin cronbach- alfa katsayısı .87'dir. Anket beşli likert tipinde hazırlanmıştır. Tamamen katılıyorum, katılıyorum, kısmen katılıyorum, katılmıyorum, hiç katılmıyorum seçeneklerinden oluşmaktadır. Anket 26 maddeden oluşmaktadır.

Verilerin analizi

Verilerin analizinde yüzde, frekans, aritmetik ortalama, standart sapma, Mann Whitney U- Testi ve Kruskal Wallis H-Testi kullanılmıştır.

BULGULAR VE YORUM

1.Alt Probleme İlişkin Bulgular

“6-7- 8. sınıf matematik dersi öğretim programında yer alan ara disiplinlere yönelik öğretmen görüşleri nelerdir?”

Aşağıda en yüksek aritmetik ortalama ve en düşük aritmetik ortalama değerine sahip anket maddelerine ilişkin bulgulara yer verilmiştir.

Anketin 4 nolu maddesinde “*ara disiplinler öğrencilerin matematiği diğer derslerle ilişkilendirmesine yardımcı olur*” ifadesi yer almaktadır. Bu maddede öğretmenlerin %35,2’ si tamamen katılıyorum seçeneğini, %50,5 i katılıyorum seçeneğini, %12,1 i kısmen katılıyorum seçeneğini, %2,2 si katılmıyorum seçeneğini işaretlemiştir. Hiç katılmıyorum seçeneğini işaretleyen öğretmen bulunmamaktadır. Bu maddeye ilişkin öğretmen görüşlerinin aritmetik ortalaması 4,19 dur. Bu anketteki en yüksek aritmetik ortalama değeridir ve öğretmen görüşlerinin ortalamasının “katılıyorum” düzeyinde olduğunu göstermektedir. Bu bulgulara göre öğretmenlerin ara disiplinlerin matematiği diğer derslerle ilişkilendirmede öğrencilere yardımcı olduğunu düşündüğü kanısına varılabilir. Anketin 2 nolu maddesi “*ara disiplinler öğrencilerin matematiği yaşamla ilişkilendirmesine yardımcı olur*” şeklindedir. Bu maddeye ilişkin öğretmen görüşleri; %38,5 tamamen katılıyorum, %41,8 katılıyorum, %17,6 kısmen katılıyorum, %2,2 katılmıyorum şeklindedir. Öğretmenlerden hiç biri hiç katılmıyorum seçeneğini işaretlememiştir. Bu maddeye yönelik öğretmen görüşlerinin aritmetik ortalaması 4,16’ dir. Bu anketteki en yüksek 2. aritmetik ortalama değeridir ve öğretmen görüşlerinin ortalamasının “katılıyorum” düzeyinde olduğunu göstermektedir. Buradan öğretmenlerin ara disiplinlerin öğrencilerin matematiği yaşamla ilişkilendirmesine yardımcı olduğunu düşündüğü yargısına ulaşılabilir. Anketin 3 nolu maddesi “*ara disiplinler öğrencilerin matematiği bazı meslek dallarıyla ilişkilendirmesine yardımcı olur*” ifadesidir. Bu maddeye ilişkin öğretmen görüşlerinin aritmetik ortalaması; %29,7 tamamen katılıyorum, %57,1 katılıyorum, %12,1 kısmen katılıyorum, %1,1 katılmıyorum şeklindedir. Öğretmenlerden hiç katılmıyorum seçeneğini işaretleyen olmamıştır. Öğretmen görüşlerinin bu maddeye ilişkin aritmetik ortalaması 4,15 ‘dir. Bu anketteki en yüksek 3. aritmetik ortalama değeridir ve öğretmen görüşlerinin ortalamasının “katılıyorum” düzeyinde olduğunu göstermektedir. Benzer şekilde öğretmenlerin ara disiplinlerin matematiği bazı meslek dallarıyla ilişkilendirdiği görüşüne katıldığı söylenilebilir. Anketteki 8 nolu madde “*matematik dersinin ara disiplinlerle ilişkilendirilmesi gereksizdir.*” ifadesidir. Bu maddeye ilişkin öğretmen görüşleri; %3,3 tamamen katılıyorum, %7,7 katılıyorum, %13,2 kısmen katılıyorum, %45,1’i katılmıyorum ve %30,8 hiç katılmıyorum şeklindedir. Bu maddeye ilişkin öğretmen görüşlerinin aritmetik ortalaması 2,08’dir. Bu değer en düşük aritmetik ortalama değeridir ve öğretmen görüşlerinin ortalamasının “katılmıyorum” düzeyinde olduğunu göstermektedir. Öğretmenler, matematik dersinin ara disiplinlerle ilişkilendirilmesinin gereksiz olduğu fikrine katılmamaktadır.

2.Alt Probleme İlişkin Bulgular

“Cinsiyete göre öğretmen görüşleri arasında anlamlı bir fark var mıdır?”

Çizelge 4’te görüldüğü gibi, Mann Whitney U-Testi sonucunda, anketin 12. ve 23. maddelerine verilen cevaplarda ,05 anlamlılık düzeyinde öğretmen görüşleri arasında cinsiyete göre anlamlı bir fark vardır ($p = .039 < .05$; $p = .001 < .05$). (12. Madde: Ara disiplin kazanımlarının edinilmesine yönelik programdaki etkinlikler yeterlidir. 23. Madde: Ara disiplin kazanımlarını ölçmeye yönelik uygulamalar yapmaktayım.)

Çizelge 4: Cinsiyet Değişkeni Açısından Mann Whitney U-Testi Sonucu

Madde	Cinsiyet	n	Sıra Ortalaması	Sıra Toplamı	U	p
Madde 12	Kadın	54	41,44	2238	753	.039
	Erkek	37	52,65	1948		
Madde 23	Kadın	54	39,02	2107	622	.001

Erkek	37	56,19	2079
-------	----	-------	------

3.Alt Probleme İlişkin Bulgular

“Kıdeme göre öğretmen görüşleri arasında anlamlı bir fark var mıdır?”

Kruskal Wallis H- Testi sonucunda, anketin 6, 10, 12, 17, 23 ve 24. maddelerine verilen cevaplarda ,05 anlamlılık düzeyinde öğretmen görüşleri arasında kıdeme göre anlamlı bir fark vardır (p < 0.05). (Maddeler sırasıyla, Öğretme-öğrenme sürecinde ara disiplin kazanımlarının edinilmesine yönelik uygulamalara yer veririm, Programda ve öğretmen kılavuz kitabında ara disiplin dallarına ve uygulamalarına yönelik verilen açıklamalar yeterlidir, Ara disiplin kazanımlarının edinilmesine yönelik programdaki etkinlikler yeterlidir, Ara disiplinlere yönelik programda yer alanlar dışında kendim ek etkinlikler hazırlıyorum, Ara disiplin kazanımlarını ölçmeye yönelik uygulamalar yapmaktayım, Ara disiplin kazanımları kazandırılabilir niteliktedir.)

Çizelge 5: Kıdem Değişkeni Açısından Kruskal Wallis H-Testi Sonucu

Maddeler	Kıdem	N	Sıra Ortalamaları	sd	χ^2	p	Anlamlı Fark
6	1-5 yıl	35	37,37	4	10,86	.028	1-5 yıl ile 6-10 yıl
	6-10 yıl	41	51,35				
	11-15 yıl	10	55,65				
	16-19 yıl	1	82,5				
	20 yıl ve üstü	4	33,38				
10	1-5 yıl	35	38,44	4	10,86	.028	1-5 yıl ile 11-15 yıl
	6-10 yıl	41	48,67				
	11-15 yıl	10	61,35				
	16-19 yıl	1	90				
	20 yıl ve üstü	4	35,38				
12	1-5 yıl	35	36,1	4	10,86	.009	1-5 yıl ile 6-10 yıl
	6-10 yıl	41	48,6				
	11-15 yıl	10	63,2				
	16-19 yıl	1	89				
	20 yıl ve üstü	4	52,25				
17	1-5 yıl	35	34,11	4	10,86	0.10	1-5 yıl ile 6-10 yıl
	6-10 yıl	41	53,43				
	11-15 yıl	10	50				
	16-19 yıl	1	42,5				
	20 yıl ve üstü	4	64,75				
23	1-5 yıl	35	37,19	4	10,86	.042	1-5 yıl ile 6-10 yıl
	6-10 yıl	41	49,51				
	11-15 yıl	10	54,55				
	16-19 yıl	1	89,5				
	20 yıl ve üstü	4	54,88				
24	1-5 yıl	35	39,07	4	10,86	.046	1-5 yıl ile 6-10 yıl
	6-10 yıl	41	51,04				
	11-15 yıl	10	52,15				
	16-19 yıl	1	86				
	20 yıl ve üstü	4	29,63				

4.Alt Probleme İlişkin Bulgular

Mezuniyet durumuna göre öğretmen görüşleri arasında anlamlı bir fark var mıdır?

Kruskal Wallis H- Testi sonucunda, anketin 26. maddesine verilen cevaplarda mezuniyet durumuna göre anlamlı bir fark vardır. (26.madde: Ara disiplin kazanımlarına ve uygulanmasına yönelik daha fazla bilgiye ihtiyacım var.)

Çizelge 6: Mezuniyet Durumu Değişkeni Açısından Kruskal Wallis H-Testi Sonucu

Madde	Mezuniyet Durumu	n	Sıra Ortalamaları	sd	χ^2	p	Anlamlı Fark
26	Eğitim Enstitüsü	5	59,1	2	8,15	0,17	Eğitim Enstitüsü ile Diğer
	Eğt. Fak. İlk. Mat.	71	45,86				Eğitim Fakültesi İlk. Mat. Öğrt. İle Diğer
	Öğr Diğer	15	46,13				

SONUÇ VE ÖNERİLER

Matematik programına ara disiplinler yerleştirilerek kazanımlar zenginleştirilmiş, öğrencilerin korkulu rüyası olan matematik dersi yaşamla ve bazı belirlenen alanlarla ilişkilendirilerek tek bir disiplin olarak sıkışıp kalması engellenmek istenmiştir (Akyol, 2011).

Araştırmada, öğretmenlerin ara disiplinler konusunda çok az ve sınırlı bilgiye sahip olduğu sonucuna ulaşılmıştır. Bu sonuç, Taş (2010)'ın araştırma sonuçlarıyla da örtüşmektedir. Anketin 'Programda ve öğretmen kılavuz kitabında ara disiplin dallarına ve uygulamalarına yönelik verilen açıklamalar yeterlidir' maddesine ilişkin öğretmen ortalaması kısmen katılıyorum düzeyindedir. Buradan, program ve öğretmen klavuz kitabının ara disiplinlere ilişkin yeterli açıklama içermediği sonucuna ulaşılabilir. Ermiş (2008) de, sosyal bilgiler dersindeki ara disiplinlerin sınıf içi uygulamalarına ilişkin öğretmen görüşlerini belirlemek amacıyla yapmış olduğu çalışmada, ara disiplinler ile ilgili verilmiş olan açıklamaların öğretmenler tarafından yetersiz bulunduğu sonucuna ulaşmıştır.

Öğretmenler, ara disiplin kazanımlarının kazandırılabilir nitelikte olduğunu düşünmektedir. Öğretmenler ara disiplinler konusunda bilgilendirmeye ihtiyaç duymaktadır. Kadın öğretmenler erkek öğretmenlere göre ara disiplinler konusunda daha fazla bilgiye ihtiyaç duymaktadır. Erkek öğretmenler kadın öğretmenlere göre ara disiplinlerin amacına ulaşması konusunda programda önemli değişikliklerin yapılmasını daha fazla savunmaktadır. Bütün kıdem türündeki öğretmenler ara disiplinlerin amacına ulaşması adına programda gerekli değişikliklerin yapılmasından yanadır. Ara disiplinlere yönelik eğitim fakültesi ilköğretim matematik öğretmenliği mezunlarının eğitim enstitüsü mezunu ve diğer mezuniyet türündeki öğretmenlerden daha bilgili olduğu söylenebilir.

Bu sonuçlardan hareketle, programın uygulayıcısı olan öğretmenlere ara disiplinler konusunda hizmet içi eğitim verilmelidir. Öğretim Programında ve öğretmen klavuz kitabında ara disiplinlere yönelik yeterli açıklama ve yönergelere yer verilmelidir.

KAYNAKLAR

- Akyol Ş. (2011). *İlköğretim II. Kademe Matematik Dersi Öğretim Programında Yer Alan Ara Disiplinlere Yönelik Öğretmen Görüşleri*. Yayımlanmamış Yüksek Lisans Tezi. Hacettepe Üniversitesi.
- Coşkun Diker Y. ve Demirel M. (2009). Proje Tabanlı Öğrenme İle Desteklenen Disiplinler Arası Öğretim Yaklaşımına İlişkin Bir Durum Çalışması. *1. Uluslar Arası Eğitim Araştırmaları Kongresi Tam Metin Bildiriler Kitabı*. 1-22.
- DENI (Department of Education). (2008). Educational (Cross-Curricular) Themes. Web: http://www.deni.gov.uk/cct_1.pdf. adresinden 10.05.2011'de alınmıştır.
- ERG. (Eğitim Reformu Girişimi). (2005). Yeni Öğretim Programlarını İnceleme ve Değerlendirme Raporu. Web: ilkogretim-online.org.tr/vol5say1/yenimufredat_raporu%5B1%5D.pdf. adresinden 10.04.2011'de alınmıştır.
- Ermiş S. (2008). *Sosyal Bilgiler Dersindeki Ara Disiplinlerin Sınıf İçi Uygulamalarına Yönelik Öğretmen Görüşleri*. Yüksek Lisans Tezi. Abant İzzet Baysal Üniversitesi.
- Karasar N. (2009). *Bilimsel Araştırma Yöntemi*. Ankara. Nobel Yayın Dağıtım.
- MEB 6-8 Sınıflar Matematik Dersi Öğretim Programı (2009). 23.04.2014 tarihinde <http://ttkb.meb.gov.tr> adresinden erişildi.
- Naval, C., Print, M. ve Iriarte, C. (2003). Civic Education in Spain: A Critical Review of Policy. http://www.jsse.org/2003-2/spain_naval.htm. adresinden 10.03.2011'de alınmıştır.
- Taş D. İ. (2010). *2005 İlköğretim Programının Hazırlanmasında Görev Alan Ara Disiplinler Komisyonu Üyelerinin Ve Sınıf Öğretmenlerinin Ara Disiplin Yaklaşımı Konusundaki Bilgi Durumu Ve Görüşlerinin Belirlenmesi*. Yayımlanmamış Yüksek Lisans Tezi. Ankara Üniversitesi.
- Yağcı E., Demirel M., Tatar Ö. (2009). Fen Ve Teknoloji Dersi Öğretim Programının Bütünleştirilmiş Program Yaklaşımını Açısından Değerlendirilmesi. Uluslar arası 5. Balkan Eğitim ve Bilim Kongresi. *Günümüzde Balkanlarda Eğitim Kongre Tam Metin Kitabı*. 148-152.

HARMANLANMIŞ ÖĞRENME ALANINDA TÜRKİYE’DE YAPILMIŞ YÜKSEK LİSANS VE DOKTORA TEZLERİNİN İNCELENMESİ

EXAMINATION OF MASTER AND DOCTORATE THESES ON THE FIELD OF BLENDED LEARNING IN TURKEY

Murat GÖKCÜL

Gazi Üniversitesi, Eğitim Bilimleri Enstitüsü, Bilgisayar ve Öğretim Teknolojileri Eğitimi
muratgokcul@gmail.com

ÖZET : Bu araştırmanın amacı; harmanlanmış öğrenme ortamları hakkında ülkemizde şimdiye kadar yapılmış yüksek lisans ve doktora tezlerini inceleyerek, araştırma eğilimlerini ortaya koymak ve gelecekte yapılacak çalışmalara ışık tutmaktır. Çalışmada herhangi bir örneklem yöntemine başvurulmamış ve çalışma evreninin tamamı incelenmiştir. Bu kapsamda, YÖK Tez Merkezi’nin web sayfasında yapılan taramalarda; 25’i yüksek lisans ve 18’i doktora seviyesinde olmak üzere toplam 43 adet teze ulaşılmıştır. Bu tezler; türlerine, araştırmanın yürütüldüğü yıllara, üniversitelere, yazım dillerine, danışmanların unvanlarına, danışmanlara, anabilim dallarına ve araştırılan değişkenlere göre incelenmiştir. İnceleme sonuçlarına göre, Harmanlanmış Öğrenme alanında; en fazla tez yürüten üniversitenin Gazi Üniversitesi olduğu (n=12), en fazla tez hazırlanan yılların 2009 ve 2011 olduğu (n=10) görülmüştür. Ayrıca Bilgisayar ve Öğretim Teknolojileri Eğitimi ana bilim dalı da, bu alanda en fazla tez hazırlayan anabilim dalı (n=16) olarak öne çıkmıştır.

Anahtar kelimeler: Harmanlanmış Öğrenme, Yüksek Lisans Tezleri, Doktora Tezleri

ABSTRACT: The purpose of this research is to identify research trends by analyzing master and doctorate theses which have been made about blended learning in our country so far and to enlighten future studies. None of sampling methods is applied in the study and all of studying group are analyzed. In this context, 25 master and 18 doctorate, totally 43 theses have been accessed during scans at webpage of YÖK Thesis Center. These theses are analyzed according to the type, year, university, written language, supervisor, title of supervisor, master of science and research variables. According to the results of the research; Gazi University has the maximum number of theses on blended learning (n=12), 2009 and 2011 are the years when maximum number of thesis are studied (n=10). In addition, Computer and Instructional Technology Education is the master of science where maximum number of theses have been studied (n=16).

Key words: Blended Learning, Master Theses, Doctorate Theses

GİRİŞ

Bilim ve teknolojiadaki değişimler ve gelişmeler hayatımızın her alanına nüfuz etmekte ve yaşam stillerimizi de değiştirmektedir. Kültürel hayatımızdan eğlence sektörüne, sağlık alanından iletişim araçlarımıza kadar çok farklı alanlarda etkisini her geçen gün daha da fazla hissettiğimiz bu gelişmeler, eğitim hayatımızı da her yönden etkilemiş ve yeni biçimlendirmelerle farklı boyutlar katmıştır.

Özelde bireydeki genelde ise toplumdaki değişime paralel olarak, öğrenme ve öğretme etkinlikleri de değişmiş ve yeni öğrenme-öğretme ortamlarına ihtiyaç duyulmuştur. Bu bağlamda, harmanlanmış öğrenme, farklı öğrenme ortamlarını harmanlayarak bireyin öğrenme ortamlarının çeşitlenmesini sağlamıştır (Bersin, 2004).

Eğitim ortamlarında bu çeşitlenmelerin kullanılması; araştırma, karşılaştırma, geliştirme ve değerlendirme çalışmalarını da beraberinde getirmiştir. Özellikle her yeni alanda ya da eğilimde yapılan araştırmalarla ilgili olarak alanyazın taramalarının yapılması, yapılmış çalışmaların incelenmesi veya belirli aralıklarla gözden geçirilmesi, ileride yapılacak çalışmalara yön vermesi açısından faydalıdır. Ayrıca bu yolla; yapılmış çalışmaların geçerli ve önyargısız bir biçimde değerlendirilmesi imkânı da sunulmaktadır (Ocak, 2010).

Ülkemizde harmanlanmış öğrenme alanında yüksek lisans veya doktora seviyesinde ilk çalışmalar 2000’li yılların başında yapılmıştır (YÖK,2014). Çok yeni sayılabilecek bu alanda yapılan çalışmalarını incelemek, nitel ve istatistik açısından analizini yapmak ve sonuçları tartışmak, alanla ilgili genel eğilimlerin ortaya konmasında ve yapılacak yeni çalışmalara ışık tutulmasında yardımcı olacaktır.

Bu amaçla çalışmamızda; harmanlanmış öğrenme alanında ülkemizde yapılmış ve YÖK web sayfasında kayıtlı yüksek lisans ve doktora tezleri incelenecek ve aşağıdaki sorulara cevaplar aranacaktır:

Harmanlanmış öğrenme alanında yapılan tezlerin;

a) Türlerine,

- b) Yıllara,
- c) Araştırmanın yürütüldüğü üniversitelere,
- d) Yazım dillerine,
- e) Danışman unvanlarına,
- f) Danışmanlarına,
- g) Anabilim dallarına,
- h) Araştırılan değişkenlere göre, dağılımları nedir?

YÖNTEM

Bu çalışmada, nitel araştırma yöntem ve teknikleri kullanılmıştır. YÖK Tez Merkezi'nden ulaşılan tezlerin doküman incelemesi ile analizi yapılmıştır (YÖK, 2014). Doküman incelenmesi, araştırılan konu veya problemle ilgili bilgi içeren yazılı kaynakların analizini ifade etmektedir (Yıldırım ve Şimşek, 2010).

Miles ve Huberman 1994 yılında yaptıkları çalışmalarında; veri analiz sürecini üç adımda incelemişlerdir (Aktaran: Yıldırım ve Şimşek, 2010):

- I) Verilerin indirgenmesi (data reduction)
- II) Verilerin görselleştirilmesi (data display)
- III) Sonuç çıkarma ve doğrulama (drawing conclusion and verification)

Verilerin indirgenmesi sürecinde; YÖK Tez Merkezi'nin web sayfasında harmanlanmış öğrenme, karma öğrenme, hibrit öğrenme, harmanlanmış öğrenim, harmanlanmış öğretim, karma öğrenim, blended learning, hybrid learning ve blended course anahtar kelimeleri kullanılarak tez taramaları yapılmıştır.

Listelenen tezler, *pdf* formatında indirilerek tam metne erişim sağlanmıştır. İzin sorunu olan ve kısıtlı kullanım imkânı bulunan tezlerin ise özetlerinden faydalanılmıştır. Bu açıdan çalışmada herhangi bir örneklem seçilmemiş, özetlerine veya tam metinlerine ulaşılan yüksek lisans ve doktora tezlerinin tamamı araştırmanın evreni olarak incelenmiştir. Ulaşılan tezlere ait bilgiler, kodlanarak Microsoft Excel programında tablolaştırılmış ve istatistik hesaplamaları da bu program aracılığı ile yapılmıştır.

Kodlanan bilgilerden araştırma sorularına uygun alt tablolar oluşturularak verilerin görselleştirilmesi sağlanmıştır. Sonuç çıkarma ve doğrulama sürecinde ise, oluşturulan alt tablolar hem nitel hem de istatistik açıdan incelenmiş ve ulaşılan sonuçlar ve öneriler 4.bölümde sunulmuştur.

BULGULAR

YÖK Tez Merkezi'nde farklı arama terimleri ile yapılan taramalarda, Tablo 1'de de görüldüğü gibi toplam 43 teze ulaşılmıştır. Ancak izin ve kısıtlı kullanım sebepleriyle bunlardan 6 tanesinin tam metnine ulaşılamamış, bu nedenle de özetlerinden faydalanılmıştır. Dolayısıyla, çalışmamızın evrenini bu 43 yüksek lisans ve doktora tezi oluşturmaktadır.

Tablo 1. Taramaların Sayısal Sonuçları

Tarama Terimi	Listelenen Sayısı	Tez
Harmanlanmış Öğrenme	22	
Karma Öğrenme	11	
Hibrit Öğrenme	1	
Harmanlanmış Öğrenim	1	
Harmanlanmış Öğretim	3	
Karma Öğrenim	2	
Blended Learning	36	
Hybrid Learning	3	
Blended Course	4	
BİLEŞİK TOPLAM	43	
TAM METNİNE ULAŞILABİLEN TEZ SAYISI	37	

Ülkemizde harmanlanmış öğrenme ortamları hakkındaki tez seviyesinde yapılan çalışmaların 10 yıllık bir geçmişi olduğu görülmektedir. Bu süreç içerisinde İngilizceden yapılan farklı çeviriler ve ortak bir kullanımın oluşturulamaması sebebiyle farklı terimlerin kullanıldığı görülmüştür. Tablo 1'de görüldüğü gibi İngilizcede "blended learning", "hybrid learning" ve "blended course" terimi ile yapılan taramalara karşılık, Türkçede harmanlanmış öğrenme, harmanlanmış öğretim, harmanlanmış öğrenim, karma öğrenme, karma öğrenim ve hibrit öğrenme anahtar kelimeleri ile ilişkilendirilmiş çalışmalar bulunmaktadır.

Tezlerin Türlerine Göre İncelenmesi

YÖK Tez Merkezinin web sayfasında yapılan taramalar sonucu ulaşılan tezlerin türlere göre dağılımı Tablo 2’de görülmektedir. Buna göre; 18 doktora ve 25 yüksek lisans tezine ulaşılmıştır.

Tablo 2. Tezlerin Türlerine Göre Dağılımı

Türü	Tez Sayısı	
	(n)	(%)
Yüksek Lisans	25	58
Doktora	18	42
TOPLAM	43	100

Tezlerin Yıllara Göre İncelenmesi

Harmanlanmış öğrenme alanında hazırlanan yüksek lisans ve doktora tezleri incelendiğinde; çalışmaların 2003-2013 yılları arasında gerçekleştirildiği ve en fazla çalışmanın 10 adet tez ve %23,2’lik bir oran ile 2009 ve 2011 yıllarında yapıldığı Tablo 3’te görülmektedir. Ayrıca 2009 yılında yapılan 6 adet doktora çalışması ile 2011 yılında yapılan 8 adet yüksek lisans çalışması da diğer yıllarla karşılaştırıldığında dikkat çekici bir seviyededir.

Tablo 3. Tezlerin Yıllara Göre Dağılımı

Yıllar	Tez Sayıları		TOPLAM	
	Yüksek Lisans	Doktora	(n)	(%)
2003	-	1	1	2,3
2005	1	-	1	2,3
2006	1	-	1	2,3
2007	1	2	3	7,0
2008	1	-	1	2,3
2009	4	6	10	23,2
2010	2	1	3	7,0
2011	8	2	10	23,2
2012	5	3	8	18,7
2013	2	3	5	11,7
TOPLAM	25	18	43	100

Tezlerin Üniversitelere Göre İncelenmesi

Tezlerin üniversitelere göre dağılımı Tablo 4’te verilmiştir. Buna göre; Harmanlanmış Öğrenme alanında en fazla tez hazırlayan üniversitenin toplam 12 tez ile Gazi Üniversitesi olduğu görülmektedir. Türkiye’de bu alanda tez yürüten üniversitelerin toplam sayısı ise 16’dır.

Tablo 4. Tezlerin Üniversitelere Göre Dağılımı

Üniversite	Tez Sayıları		TOPLAM	
	Yüksek Lisans	Doktora	(n)	(%)
Gazi	5	7	12	28,0
ODTÜ	1	5	6	14,0
Hacettepe	4	1	5	11,6
Fırat	4	0	4	9,3
Anadolu	1	2	3	7,0
Celal Bayar	2	0	2	4,7
Bilkent	2	0	2	4,7
Ahi Evran	1	0	1	2,3
Dicle	0	1	1	2,3
Marmara	0	1	1	2,3
Dokuz Eylül	1	0	1	2,3
Sakarya	1	0	1	2,3
Yıldız Teknik	0	1	1	2,3
Zonguldak Karaelmas	1	0	1	2,3
Mustafa Kemal	1	0	1	2,3
Selçuk	1	0	1	2,3
TOPLAM	25	18	43	100

Tezlerin Yazım Dillerine Göre İncelenmesi

Tezlerin yazım dili incelendiğinde; Tablo 5’te de görüleceği gibi, 34 tez Türkçe, 9 tez ise İngilizce yazılmıştır.

Tablo 5. Tezlerin Yazım Dillerine Göre Dağılımı

Dili	Tez Sayıları		TOPLAM	
	Yüksek Lisans	Doktora	(n)	(%)
Türkçe	22	12	34	79
İngilizce	3	6	9	21
TOPLAM	25	18	43	100

Tezlerin %79’luk bir oranda Türkçe yazıldığı görülmektedir. İngilizce yazılan tezlerin ise; 6 tanesi ODTÜ, 2 tanesi Bilkent ve 1 tanesi de Anadolu Üniversitesi’ne aittir.

Tezlerin Danışman Unvanlarına Göre İncelenmesi

Yapılan tezlerin danışmanlarına göre bir inceleme yapıldığında, unvanlara göre eşit sayılabilecek bir dağılım ortaya çıkmaktadır. Tablo 6’ya bakıldığında, 13 tezin Prof.Dr., 14 tezin Doç.Dr. ve 16 tezin de Yrd.Doç.Dr. unvanlı danışmanlar tarafından yürütüldüğü görülmektedir.

Tablo 6. Tezlerin Danışman Unvanlarına Göre Dağılımı

Unvan	Tez Sayıları		TOPLAM	
	Yüksek Lisans	Doktora	(n)	(%)
Prof.Dr.	3	10	13	30,3
Doç.Dr.	8	6	14	32,5
Yrd.Doç.Dr.	14	2	16	37,2
TOPLAM	25	18	43	100

Ayrıca Prof.Dr. unvanlı danışmanların doktora tezlerine, Yrd.Doç.Dr. unvanlı danışmanların ise yüksek lisans tezlerine daha fazla danışmanlık yaptığı söylenebilir.

Tezlerin Danışmanlarına Göre İncelenmesi

Tezlerin danışmanlarına göre incelendiği Tablo 7’ye bakıldığında, en fazla tez (n=4) danışmanlığı yapanların; Orta Doğu Teknik Üniversitesi’nden Prof.Dr. M.Yaşar Özden ile Gazi Üniversitesi’nden Doç.Dr. M.Akif Ocak olduğu görülmektedir.

Tablo 7. Tezlerin Danışmanlarına Göre Dağılımı

Danışman	Üniversite	Tez Sayıları		TOPLAM (n)
		Yüksek Lisans	Doktora	
Prof.Dr. M.Yaşar Özden	O.D.T.Ü.	-	4	4
Doç.Dr. M.Akif Ocak	Gazi Üniversitesi	3	1	4
Prof.Dr. H.İbrahim Yalın	Gazi Üniversitesi	-	2	2
Doç.Dr. Osman Nafiz Kaya	Fırat Üniversitesi	2	-	2
Yrd.Doç.Dr. Hasan Çakır	Gazi Üniversitesi	2	-	2

Tezlerin Ana Bilim Dallarına Göre İncelenmesi

YÖK Tez Merkezinin web sayfasından ulaşılan 43 tezin ana bilim dallarına göre dağılımını gösteren Tablo 8 aşağıdadır.

Tablo 8. Tezlerin Ana Bilim Dallarına Göre Dağılımı

Ana Bilim dalı	Tez Sayıları		TOPLAM	
	Yüksek Lisans	Doktora	(n)	(%)
B.Ö.T.E.	11	5	16	37,2
E.P.Ö.	4	3	7	16,2
Fen Bilgisi Eğitimi	3	1	4	9,3
Eğitim Teknolojisi	-	2	2	4,7
İlköğretim	1	1	2	2,3
İngilizce Eğitimi	1	1	2	2,3
Ortaöğretim Fen ve Matematik Eğitimi	2	-	2	2,3
Uzaktan Eğitim	1	-	1	2,3

Elektrik-Elektronik Mühendisliği	-	1	1	2,3
Eğitim Bilimleri	-	1	1	2,3
Beden Eğitimi ve Spor Öğretmenliği	-	1	1	2,3
Biyoloji Eğitimi	-	1	1	2,3
Coğrafya Eğitimi	-	1	1	2,3
Fizik Eğitimi	1	-	1	2,3
Sınıf Öğretmenliği	1	-	1	2,3
TOPLAM	25	18	43	100

Buna göre; en fazla tez çalışmasının yürütüldüğü ana bilim dalı Bilgisayar ve Öğretim Teknolojileri Eğitimi'dir (n=16 %37,2).

Harmanlanmış öğrenme alanının, yüksek lisans ve doktora tezleri aracılığı ile ilişkilendirildiği ana bilim dalı toplam sayısı ise 15'tir.

Tezlerin Araştırılan Değişkenlere Göre İncelenmesi

Ulaşılan tezler araştırılan değişkenler bakımından incelendiğinde Tablo 9'de görülen dağılım ortaya çıkmıştır.

Tablo 9. Tezlerin Araştırılan Değişkenlere Göre Dağılımı

Araştırılan Değişkenler	Tez Sayıları		TOPLAM
	Yüksek Lisans	Doktora	
Akademik Başarıya Etkisi	9	7	16
Kalıcılığa Etkisi	1	1	2
Tutuma Etkisi	8	3	11
Motivasyona Etkisi	4	4	8
Özyeterlik Algılarına Etkisi	2	1	3
Derse Katılıma Etkisi	2	1	3
Öğrenci Görüşleri	3	0	3
Öğrenci Algılarına Etkisi	1	3	4
Psikomotor Becerilere Etkisi	1	1	2
Doyum Üzerindeki Etkisi	0	1	1
Öğretmen / Öğretim Elemanlarının Görüşleri	3	0	3
Öğretmen Algıları	0	1	1
Memnuniyete Etkisi	1	2	3
Öğrenci Etkileşimlerine Etkisi	0	1	1
Öğrenme Düzeylerine Etkisi	0	2	2
Sunum Hazırlama Becerilerine Etkisi	1	0	1
İletişim Becerilerine Etkisi	1	0	1
Dinleme ve Konuşma Becerilerine Etkisi	0	1	1
Bağımsız Öğrenme Becerilerine Etkisi	2	1	3
Bilgi Transferine Etkisi	1	0	1
Bilişsel Becerilerin Gelişimine Etkisi	2	0	2
Ortamın Etkililiğini Değerlendirme	0	1	1
Bir Ders Ortamı Geliştirme	0	1	1
Öğrenme Stillerine Etkisi	1	0	1
Yazılım Algoritması Oluşturma	0	1	1
Web Materyali Kullanma Davranışlarına Etkisi	0	1	1
Özdüzenleme Becerilerine Etkisi	1	0	1
Öğretim Bulunuşluğuna Etkisi	0	1	1
Sosyal Bulunuşluğa Etkisi	0	1	1
Bilimsel Araştırmaları Anlamaya Etkisi	1	0	1
Bilimin Doğasını Anlamaya Etkisi	1	0	1
TOPLAM	46	36	82

Araştırmalarda araştırılan değişkenlerin toplam sayısı 31'dir. Bu değişkenler arasında çoğunlukla, harmanlanmış öğrenme ortamlarının akademik başarı (n=16), tutum (n=11) ve motivasyon (n=8) üzerindeki etkilerinin incelendiği görülmektedir.

SONUÇLAR VE ÖNERİLER

Türkiye’de harmanlanmış öğrenme alanında yapılmış yüksek lisans ve doktora tezlerinin incelendiği bu çalışmada, aşağıdaki sonuçlar elde edilmiştir:

- Ülkemizde harmanlanmış öğrenme alanında yapılmış ve YÖK Tez Merkezi’nden ulaşılabilen 25’i yüksek lisans ve 18’i doktora olmak üzere toplam 43 adet tez bulunmaktadır. Ancak bu tezlerden; bu çalışmanın yapıldığı tarih itibariyle izin ve kısıtlı kullanım sebebiyle 37 tanesinin tam metnine ulaşılabildiği *pdf* formatında indirilmesine imkân vardır.
- Harmanlanmış öğrenme alanı için yapılan taramalarda, harmanlanmış öğrenme anahtar kelimesi ile birlikte; karma öğrenme, hibrit öğrenme, harmanlanmış öğrenim, harmanlanmış öğretim ve karma öğrenim ifadeleri de kullanılmıştır. İngilizce yapılan taramalarda ise blended learning, hybrid learning ve blended course anahtar kelimeleri kullanılmıştır.
- En fazla tez hazırlanan yılların 2009 ve 2011 yılları olduğu görülmüştür (n=10).
- Harmanlanmış öğrenme alanında en fazla tez hazırlayan üniversite, 5’i yüksek lisans 7’si doktora olmak üzere 12 tez ile Gazi Üniversitesi’dir.
- Hazırlanan tezlerin %79’unda yazım dili olarak Türkçe kullanılırken, %21’inde İngilizce kullanılmıştır.
- Tezlerin danışmanlığını yürüten hocaların unvanlarına göre de birbirine yakın bir dağılım göze çarpmaktadır.
- Bu alanda en fazla tez danışmanlığı yapan hocalar; 4 tez danışmanlığı ile Orta Doğu Teknik Üniversitesi’nden Prof.Dr. M.Yaşar Özden ile Gazi Üniversitesi’nden Doç.Dr. M.Akif Ocak’tır.
- Bilgisayar ve Öğretim Teknolojileri Eğitimi ana bilim dalı, 16 tez ile en fazla tez yürüten ana bilim dalıdır (%37,2).
- Tezler araştırılan değişkenlere göre incelendiğinde, en çok araştırılan temaların akademik başarı, tutum ve motivasyon olduğu görülmüştür.

Bu araştırmada elde edilen bulgulara göre; ülkemizde harmanlanmış öğrenme çalışmalarının son 5 yılda hız kazandığı görülmektedir. Hazırlanan tezlerin sonuçlarına bakıldığında HÖ ortamları hakkında daha fazla çalışmanın yapılmasına ihtiyaç olduğu söylenebilir.

Tez çalışmalarını yürüten ana bilim dalları incelendiğinde 16 adet farklı A.B.D. karşımıza çıkmaktadır. Yeni bir alan olması sebebiyle dar bir boyutta kaldığı görülen harmanlanmış öğrenme çalışmalarının spordan müziğe, mühendislik bilimlerinden tıp sektörüne kadar uzanan geniş bir yelpazede araştırılması ve buna uygun öğrenme ortamlarının tasarlanması gerektiği düşünülmektedir.

Ayrıca yapılan tezlerde dikkat çeken bir diğer önemli nokta ise; harmanlamanın genelde etkinlik ve ders düzeyinde olduğudur. Bu açıdan; program ve kurumsal düzeyde yapılacak harmanlanmış öğrenme çalışmalarına ihtiyaç olduğu düşünülmektedir.

KAYNAKLAR

- Bersin, J.(2004). The Blended Learning Book. San Francisco. Pfeiffer.
- Ocak, M,A.(2010). Alanyazın Taraması. Ankara. Nobel Kitapevi.
- Yıldırım, A. ve Şimşek, H.(2013). Sosyal Bilimlerde Nitel Araştırma Teknikleri (9.Baskı). Ankara. Seçkin Yayıncılık.
- YÖK (2014). Tez Merkezi Tarama Sonuçları. 08.04.2014 tarihinde <https://tez.yok.gov.tr/UlusalTezMerkezi/> adresinden ulaşılmıştır.

PROSPECTIVE MIDDLE SCHOOL MATHEMATICS TEACHERS' COMPUTATIONAL ESTIMATION STRATEGIES FOR ADDITION

Seçil YEMEN-KARPUZCU

Rukiye AYAN

Mine IŞIKSAL-BOSTAN

Computational estimation (CE) tasks of number sense are important for understanding numbers and quantities as conceptual environments (Greeno, 1991). To develop students productively in CE, mathematics teachers also need to have skills to make CEs and understand conceptually the numbers and operations. The aim of this study was to identify the prospective middle school mathematics teachers' CE strategies regarding addition operation. Data were collected from 37 junior prospective teachers who were attending to the methods of teaching mathematics course in a public university in Turkey as a part of the methods of teaching mathematics course. Data collection instrument involved 3 open-ended CE tasks. In different contexts, the tasks (1, 2, 3) included adding 7 numbers between 5 and 13, 7 numbers between 26 and 76, 8 numbers between 35 and 92, respectively. Participants were required to estimate the sum of the numbers and explain their strategies in detail. The data were analyzed using Sowder and Wheeler's (1989) skill components in CE and Dowker's (1992) strategy classification. The researchers analyzed the written responses until full consensus was reached on categories that strategies fall into. The responses for both the strategies and the interval of estimation values were identified to catch the trend of strategies. In task 1, most of the students had a good estimation using averaging strategy or using both compatible numbers and rounding strategies. Most of the students had a good estimation using rounding strategy in task 2. Lastly, some students had a good estimation using rounding strategy in tasks 3. Another group of students had a moderate estimation using averaging or rounding strategy. The findings indicated that while averaging strategy was highly preferred for task 1, rounding strategy was preferred for tasks 2 and 3. Therefore, the strategies were not quite diversified for estimation.

Keywords: Computational Estimation; Prospective Middle School Mathematics Teachers

INVESTIGATING MASTER THESIS AND DOCTORAL DISSERTATIONS ABOUT NATURE OF SCIENCE: TURKEY SAMPLE

It's become crucial to make students realize the nature of science properly soon after renewed Science and Technology course curriculum, in 2005, which aimed to educate science literate individuals as a major vision. It has come up as a cognitive learning goal instead of affective byproduct, thus, researches connected to nature of science has increased until 2005. Current study aims to investigate master thesis and doctoral dissertations carried out in Turkey and about nature of science. In this context, universe of the study was consisted of dissertations reached from the National Dissertation which is contained within Center Council of Higher Education. 52 dissertations were investigated because of having problems accessing to some studies. Document analysis was preferred as a qualitative research method. It was seen that the studies aimed to determine views about nature of science concluded that many of the students and the teachers interiorized non-contemporary conceptions. Besides, analysis of the studies aimed to develop views on nature of science showed that making a special effort on individuals to make them sense of nature of science provides to bring contemporary to views. As a consequence it is suggested to give place to nature of science as objectives in curriculum and enriching activities of Ministry of Education textbooks related to nature of science.

Key Words: Nature of science, thesis and dissertations.

ÖĞRENCİLERİN MOBİL TEKNOLOJİLERE İLİŞKİN ÖN BİLGİ DÜZEYLERİNİN FARKLI DEĞİŞKENLER AÇISINDAN İNCELENMESİ

EXAMINATION OF STUDENTS' PRIOR KNOWLEDGE LEVEL OF MOBILE TECHNOLOGY USING DIFFERENT VARIABLES

Yusuf Ziya OLPAK
Ahi Evran Üniversitesi
yusufziyaolpak@gmail.com

Agah Tuğrul KORUCU
Necmettin Erbakan Üniversitesi
agah.korucu@gmail.com

ÖZET: Bu araştırma kapsamında, öğrencilerin mobil teknolojilere ilişkin ön bilgi düzeylerinin farklı değişkenler ile olan ilişkisini incelemek amaçlanmıştır. Tarama modeline göre yürütülen araştırma, kullanılan veri toplama araçlarındaki sorulara uygun şekilde yanıtlar veren 309 öğrenciden elde edilen veriler ile gerçekleştirilmiştir. Verilerin toplanmasında; yazarlar tarafından yükseköğretimdeki öğrencilerin mobil teknolojilere ilişkin ön bilgi düzeylerinin belirlenebilmesine yönelik olarak geliştirilen veri toplama aracından faydalanılmıştır. Verilerin çözümlenmesinde ise; ilişkisiz örneklem için t-testi ve ilişkisiz örneklem için tek faktörlü varyans analizi kullanılmıştır. Araştırma sonucunda ulaşılan bulgular; öğrencilerin mobil teknolojilere ilişkin ön bilgi düzeyi puanlarının, sahip oldukları mobil cihaz(lar)a ve haftalık internet kullanım süresine göre değiştiğini ancak cinsiyete göre değişmediğini göstermiştir.

Anahtar sözcükler: mobil teknolojiler, öğretmen adayı, ön bilgi

ABSTRACT: In this study, it is aimed to examine students' level of prior knowledge of mobile technologies using different variables. The study was planned and carried out in accordance with the survey model, and the data were obtained from 309 students who gave proper answers the questions contained in the data collection tools. The data collection tools developed by the authors to determine university students' level of mobile technology prior knowledge were used. The independent samples t-test and one-way ANOVA were used to analyze the data. The findings show that the students' scores that represent their mobile technology prior knowledge levels vary depending on the mobile device(s) they have and their weekly internet usage, not their sex.

Keywords: mobile technologies, preservice teacher, prior knowledge

GİRİŞ

Çağımızda teknolojik olarak yaşanan hızlı gelişmelerden dolayı, üretilen bilgi miktarı da hızla artmaktadır. Bireylerin bu hızlı değişime ayak uydurabilmeleri için, yaşam boyu öğrenmeye açık olmaları ve ihtiyaç duydukları bilgileri istedikleri zaman öğrenebilmeleri önem arz etmektedir. Bu bağlamda eğitim etkinliklerinde kullanılabilecek teknolojiler de değişim ve gelişim göstermektedir. Bunlardan biri de son zamanlarda üzerinde sıkça durulan mobil teknolojilerdir. Mobil teknolojiler taşınabilirlik/hareketlilik, hızlı erişilebilirlik ve bağlantılabilirlik gibi özellikleri ile diğer eğitim teknolojilerinden ayrılmaktadır ve mobil cihazlar öğrencilerin öğrenme şekillerini değiştirmektedir (Song, 2011). Mobil öğrenme ile ilgili ilk araştırmalar 1990'ların sonlarına doğru başlamıştır ve günümüzde yaşanan teknolojik gelişmelere paralel olarak da büyük bir hızla devam etmektedir (Woodill, 2010, s. 9). Alanyazında mobil öğrenme ile ilgili yapılan ilk tanımlarda teknoloji odak noktası olarak alınmış ve mobil öğrenme, bir mobil cihaz aracılığıyla öğrenme şeklinde ifade edilmiştir (Woodill, 2010, s. 14). Ancak zaman içerisinde farklı araştırmacılar tarafından çeşitli tanımlar yapılmıştır (Geddes, 2004; Keegan, 2005; O'Malley ve diğerleri, 2005). Avrupa'da mobil öğrenme ile ilgili çok yıllık bir çalışma olan MOBIlearn projesinde ise, mobil öğrenme; öğrencilerin önceden belirlenmiş bir yerde sabit olarak kalmasına gerek olmadan, mobil teknolojiler tarafından sağlanan öğrenme fırsatları ile ilgili avantajları kullanarak, gerçekleştirdikleri her türlü öğrenme olarak tanımlanmıştır (Vavoula, 2005).

Mobil öğrenmenin; zamandan ve mekândan bağımsız olarak bilgiye erişebilmeye imkân sağlaması, öğrenmeyi destekleyici farklı araçları kullanabilme imkânı tanınması, iletişimi artırması ve yaşam boyu öğrenmeye olanak sağlaması gibi avantajlarının (Al-Fahad, 2009; Bulun, Gülnar ve Güran, 2004; Uzunboylu, Cavus ve Ercag, 2009) yanı sıra; mobil cihazların genel özelliklerinden kaynaklanan (küçük ekran boyutları nedeni ile gezintide

ve okumada yaşanan güçlükler, internete erişim için gereken ilave maliyet, küçük olan tuş takımları veya klavyeler nedeni ile metin girişindeki zorluklar ve sınırlı pil ömrü vb.) dezavantajları (Stockwell, 2007; Thornton ve Houser, 2002; Waycott and Kukulska-Hulme, 2003) da bulunmaktadır..

Mobil öğrenmenin avantajlarından en iyi şekilde yararlanıp dezavantajlarından da en az derecede etkilenmek için, tasarlanan öğrenme ortamlarının öğretme-öğrenme etkinliklerinin merkezinde yer alan öğrencilerin ihtiyaçlarına en iyi şekilde cevap vermesi gerekmektedir. Bu noktada öğrencilerin ön bilgilerinin dikkate alınması da oldukça önemlidir ve ancak böyle, öğretme-öğrenme için uygun ortamlar tasarlanabilir. Ayrıca öğretmen adaylarının geleceğin nesillerini yetiştirecekleri göz önünde bulundurulursa aldıkları eğitimin kalitesinin ne kadar önemli olduğu daha da iyi anlaşılacaktır. Çünkü; artık günlük hayatın bir parçası haline gelen mobil uygulamaların (hastane randevusu alma, ulaşım araçları ile ilgili sefer saatlerini öğrenme, uçak bileti alma vb.) eğitim etkinliklerinde de kullanılması kaçınılmaz hale geldiğinden, öğrencilerin mobil teknolojilere ilişkin ön bilgi düzeylerinin belirlenmesi önemlidir. Bu bağlamda bu araştırma kapsamında, öğretmen adaylarının mobil teknolojilere ilişkin ön bilgi düzeylerinin farklı değişkenler ile olan ilişkisini incelemek amaçlanmıştır. Bu genel amaç çerçevesinde de aşağıdaki sorulara cevap aranmıştır:

1. Öğrencilerin mobil teknolojilere ilişkin ön bilgi düzeyleri sahip oldukları mobil cihaz(lar)a göre anlamlı bir farklılık göstermekte midir?
2. Öğrencilerin mobil teknolojilere ilişkin ön bilgi düzeyleri cinsiyete göre anlamlı bir farklılık göstermekte midir?
3. Öğrencilerin mobil teknolojilere ilişkin ön bilgi düzeyleri haftalık internet kullanım süresine göre anlamlı bir farklılık göstermekte midir?

YÖNTEM

Araştırmanın Modeli ve Çalışma Grubu

Tarama modeline göre yürütülen bu araştırma, 2013-2014 eğitim-öğretim yılı Bahar döneminde, Necmettin Erbakan Üniversitesi eğitim fakültesi öğrencilerinden araştırma kapsamında kullanılan veri toplama aracındaki sorulara uygun şekilde yanıt veren 309 öğrenciden elde edilen veriler ile gerçekleştirilmiştir.

Veri Toplama Araçları

Araştırma kapsamında, yazarlar tarafından yükseköğretimdeki öğrencilerin mobil teknolojilere ilişkin ön bilgi düzeylerinin belirlenebilmesine yönelik olarak geliştirilen veri toplama aracından faydalanılmıştır. Belirtilen veri toplama aracı geliştirilirken kapsamlı bir alanyazın taraması yapılmış ve oluşturulan taslak maddeler kapsam geçerliliği ve hedeflere uygunluğu açısından beş farklı alan uzmanının görüşüne sunulmuştur. Uzmanlardan alınan geribildirimler doğrultusunda veri toplama aracı (Ek-1) tekrar düzenlenmiş ve son hâli verilerek araştırma kapsamında kullanılmıştır. Veri toplama aracı kişisel bilgiler ilgili maddeler ve mobil teknolojilere ilişkin ön bilgi düzeyini belirlemeye yönelik maddeler olmak üzere iki bölümden oluşmaktadır. Öğrencilerin mobil teknolojilere ilişkin ön bilgi düzeyleri bu maddelerden ne kadar puan aldıklarına göre belirlenmektedir ve puanların artması yüksek ön bilgi düzeyini azalması ise düşük ön bilgi düzeyini göstermektedir. Veri toplama aracının araştırma kapsamında elde edilen verilerle hesaplanan Cronbach α güvenilirlik katsayısı ise; 0.73'tür ve güvenilirlik açısından kabul edilebilir düzeydedir.

Verilerin Çözümlemesi

Araştırma kapsamında elde edilen veriler SPSS (The Statistical Package for The Social Sciences) paket programı kullanılarak çözümlenmiş ve tüm hipotezler 0.95 güven düzeyinde ($p = 0.05$) test edilmiştir. Araştırma kapsamında elde edilen veriler parametrik test varsayımlarını karşıladığından, verilerin çözümlenmesinde parametrik testlerden (ilişkisiz örneklem için t-testi ve ilişkisiz örneklem için tek faktörlü varyans analizi) yararlanılmıştır.

BULGULAR

Öğrencilerin mobil teknolojilere ilişkin ön bilgi düzeylerinin sahip oldukları mobil cihaz(lar)a göre anlamlı bir farklılık gösterip göstermediğine yönelik bulgular:

Öğrencilerin mobil teknolojilere ilişkin ön bilgi düzeylerinin sahip oldukları mobil cihaz(lar)a göre anlamlı bir farklılık gösterip göstermediğini çözümlemek için, ilişkisiz örneklem için tek faktörlü varyans analizi kullanılmıştır. Öğrencilerin mobil teknolojilere ilişkin ön bilgi düzeyi puanlarının sahip oldukları mobil cihaz(lar)a göre ortalamaları ve standart sapma değerleri Tablo 1'de verilmiştir.

Tablo 1. Öğrencilerin Mobil Teknolojilere İlişkin Ön bilgi Düzeyi Puanlarının Sahip Oldukları Mobil Cihaz(lar)a Göre Betimsel İstatistikleri

Sahip Olunan Mobil Cihaz(lar)	N	\bar{X}	S
1) Akıllı Telefon	27	9.37	1.925
2) Akıllı Telefon, Dizüstü Bilgisayar	120	9.94	1.204
3) Akıllı Telefon, Minibook (Netbook)	2	10.00	.000
4) Akıllı Telefon, Tablet (iPad, Samsung Tab vb.)	21	9.67	1.528
5) Cep Telefonu	32	8.13	2.121
6) Cep Telefonu, Dizüstü Bilgisayar	83	9.17	2.129
7) Cep Telefonu, Tablet (iPad, Samsung Tab vb.)	16	9.56	1.315
8) Cep Telefonu, Minibook (Netbook)	8	9.88	1.126
Toplam	309	9.46	1.762

Tablo 1’de de görüldüğü gibi; ‘Akıllı Telefon’ sahibi olan öğrencilerin mobil teknolojilere ilişkin ön bilgi düzeyi puanlarının ortalaması 9.37, ‘Akıllı Telefon ve Dizüstü Bilgisayar’ sahibi olanları 9.94, ‘Akıllı Telefon ve Minibook (Netbook)’ sahibi olanları 10.00, ‘Akıllı Telefon ve Tablet (iPad, Samsung Tab vb.)’ sahibi olanları 9.67, ‘Cep Telefonu’ sahibi olanları 8.13, ‘Cep Telefonu ve Dizüstü Bilgisayar’ sahibi olanları 9.17, ‘Cep Telefonu ve Tablet (iPad, Samsung Tab vb.)’ sahibi olanları 9.56 ve ‘Cep Telefonu ve Minibook (Netbook)’ sahibi olanları 9.88’dir. Öğrencilerin mobil teknolojilere ilişkin ön bilgi düzeyi puanlarının sahip oldukları mobil cihaz(lar)a göre anlamlı bir farklılık gösterip göstermediğine dair bulgular ise Tablo 2’de verilmiştir.

Tablo 2. Öğrencilerin Mobil Teknolojilere İlişkin Ön bilgi Düzeyi Puanlarının Sahip Oldukları Mobil Cihaz(lar)a Göre ANOVA Sonuçları

Varyansın Kaynağı	Kareler Toplamı	Sd	Kareler Ortalaması	F	p
Gruplararası	95.155	7	13.594	4.749	.000
Gruplarıçi	861.506	301	2.862		
Toplam	956.660	308			

Tablo 3. Çoklu Karşılaştırma -Tukey Testi- Sonuçları

Yöntem	1	2	3	4	5	6	7	8
1) Akıllı Telefon	-	-	-	-	-	-	-	-
2) Akıllı Telefon, Dizüstü Bilgisayar	-	-	-	-	*	*	-	-
3) Akıllı Telefon, Minibook (Netbook)	-	-	-	-	-	-	-	-
4) Akıllı Telefon, Tablet (iPad, Samsung Tab vb.)	-	-	-	-	*	-	-	-
5) Cep Telefonu	-	*	-	*	-	-	-	-
6) Cep Telefonu, Dizüstü Bilgisayar	-	*	-	-	-	-	-	-
7) Cep Telefonu, Tablet (iPad, Samsung Tab vb.)	-	-	-	-	-	-	-	-
8) Cep Telefonu, Minibook (Netbook)	-	-	-	-	-	-	-	-

Tablo 2’de de görüldüğü gibi, ilişkisiz örneklem için tek faktörlü varyans analizi kullanılarak elde edilen bulgulara göre, öğrencilerin mobil teknolojilere ilişkin ön bilgi düzeyi puanları sahip oldukları mobil cihaz(lar)a göre anlamlı bir farklılık göstermektedir [$F_{(7-301)}=4.749$, $p<.05$]. Diğer bir ifadeyle, öğrencilerin mobil teknolojilere ilişkin ön bilgi düzeyi puanları sahip oldukları mobil cihaz(lar)a göre değişmektedir. Farklılıkların hangi ikili gruptan kaynaklandığını gösteren çoklu karşılaştırma testi (Tukey testi) sonuçlarına ilişkin Tablo 3 incelendiğinde; “Akıllı Telefon, Dizüstü Bilgisayar” - “Cep Telefonu”, “Akıllı Telefon, Dizüstü Bilgisayar” - “Cep Telefonu, Dizüstü Bilgisayar” ve “Akıllı Telefon, Tablet (iPad, Samsung Tab vb.)” - “Cep Telefonu” (2-5, 2-6 ve 4-5) sahibi olan öğrencilerin mobil teknolojilere ilişkin ön bilgi düzeyi puanları arasında anlamlı bir fark olduğu görülmektedir.

Öğrencilerin mobil teknolojilere ilişkin ön bilgi düzeylerinin cinsiyete göre anlamlı bir farklılık gösterip göstermediğine yönelik bulgular:

Öğrencilerin mobil teknolojilere ilişkin ön bilgi düzeylerinin cinsiyete göre t-testi sonuçları Tablo 4’te verilmiştir.

Tablo 4. Öğrencilerin Mobil Teknolojilere İlişkin Ön bilgi Düzeyi Puanlarının Cinsiyete Göre T-Testi Sonuçları

Cinsiyet	N	\bar{X}	S	Sd	T	P
Kadın	184	9.29	1.764	307	2.047	0.42
Erkek	125	9.70	1.737			

Tablo 4’te de görüldüğü gibi, ilişkisiz örneklemeler için t-testi kullanılarak elde edilen bulgulara göre, öğrencilerin mobil teknolojilere ilişkin ön bilgi düzeyi puanları cinsiyete göre anlamlı bir farklılık göstermemektedir ($p > .05$). Diğer bir ifadeyle, öğrencilerin mobil teknolojilere ilişkin ön bilgi düzeyi puanları cinsiyete göre değişmemektedir.

Öğrencilerin mobil teknolojilere ilişkin ön bilgi düzeylerinin haftalık internet kullanım süresine göre anlamlı bir farklılık gösterip göstermediğine yönelik bulgular:

Öğrencilerin mobil teknolojilere ilişkin ön bilgi düzeylerinin haftalık internet kullanım süresine göre anlamlı bir farklılık gösterip göstermediğini çözümlmek için, ilişkisiz örneklemeler için tek faktörlü varyans analizi kullanılmıştır. Öğrencilerin mobil teknolojilere ilişkin ön bilgi düzeyi puanlarının haftalık internet kullanım süresine göre ortalamaları ve standart sapma değerleri Tablo 5’te verilmiştir.

Tablo 5. Öğrencilerin Mobil Teknolojilere İlişkin Ön bilgi Düzeyi Puanlarının Haftalık İnternet Kullanım Süresine Göre Betimsel İstatistikleri

Haftalık İnternet Kullanım Süresi	N	\bar{X}	S
0-3 saat	70	8.77	1.987
3-6 saat	95	9.53	1.428
6-9 saat	62	9.73	1.776
9 saat ve üzeri	82	9.76	1.775
Toplam	309	9.46	1.762

Tablo 5’te de görüldüğü gibi; haftada 0-3 saat arasında internet kullanan öğrencilerin mobil teknolojilere ilişkin ön bilgi düzeyi puanlarının ortalaması 8.77, haftada 3-6 saat arasında internet kullananlarınki 9.53, haftada 6-9 saat arasında internet kullananlarınki 9.73 ve haftada 9 saat ve üzerinde internet kullananlarınki 9.76’dır. Öğrencilerin mobil teknolojilere ilişkin ön bilgi düzeyi puanlarının haftalık internet kullanım süresine göre anlamlı bir farklılık gösterip göstermediğine dair bulgular ise Tablo 6’da verilmiştir.

Tablo 6. Öğrencilerin Mobil Teknolojilere İlişkin Ön bilgi Düzeyi Puanlarının Haftalık İnternet Kullanım Süresine Göre ANOVA Sonuçları

Varyansın Kaynağı	Kareler Toplamı	Sd	Kareler Ortalaması	F	P
Gruplararası	45.172	3	15.057	5.039	.002
Gruplarıçi	911.488	305	2.988		
Toplam	956.660	308			

Tablo 7. Çoklu Karşılaştırma -Tukey Testi- Sonuçları

Yöntem	1	2	3	4
1) 0-3 saat	-	*	*	*
2) 3-6 saat	*	-	-	-
3) 6-9 saat	*	-	-	-
4) 9 saat ve üzeri	*	-	-	-

Tablo 6’da da görüldüğü gibi, ilişkisiz örneklemeler için tek faktörlü varyans analizi kullanılarak elde edilen bulgulara göre, öğrencilerin mobil teknolojilere ilişkin ön bilgi düzeyi puanları haftalık internet kullanım süresine göre anlamlı bir farklılık göstermektedir [$F_{(3,305)}=5.039$, $p<.05$]. Diğer bir ifadeyle, öğrencilerin mobil teknolojilere ilişkin ön bilgi düzeyi puanları haftalık internet kullanım süresine göre değişmektedir. Farklılıkların hangi ikili gruptan kaynaklandığını gösteren çoklu karşılaştırma testi (Tukey testi) sonuçlarına ilişkin Tablo 7 incelendiğinde; “0-3 saat” - “3-6 saat”, “0-3 saat” - “6-9 saat” ve “0-3 saat” - “9 saat ve üzeri” (1-2, 1-3 ve 1-4) haftalık internet kullanım süresine sahip öğrencilerin mobil teknolojilere ilişkin ön bilgi düzeyi puanları arasında anlamlı bir fark olduğu görülmektedir.

SONUÇ

Bu araştırma sonucunda, öğrencilerin mobil teknolojilere ilişkin ön bilgi düzeyi puanları sahip oldukları mobil cihaz(lar)a ve haftalık internet kullanım süresine göre anlamlı bir farklılık göstermiştir. Ancak, öğrencilerin mobil teknolojilere ilişkin ön bilgi düzeyi puanları cinsiyete göre anlamlı bir farklılık göstermemiştir. Bulgular ayrıntılı olarak incelendiğinde ise; “Akıllı Telefon, Dizüstü Bilgisayar” - “Cep Telefonu”, “Akıllı Telefon, Dizüstü Bilgisayar” - “Cep Telefonu, Dizüstü Bilgisayar” ve “Akıllı Telefon, Tablet (iPad, Samsung Tab vb.)” - “Cep Telefonu” (2-5, 2-6 ve 4-5) sahibi olan öğrencilerin mobil teknolojilere ilişkin ön bilgi düzeyi puanları arasında anlamlı bir fark olduğu görülmektedir. Ayrıca; “0-3 saat” - “3-6 saat”, “0-3 saat” - “6-9 saat” ve “0-3

saat” - “9 saat ve üzeri” (1-2, 1-3 ve 1-4) haftalık internet kullanım süresine sahip öğrencilerin mobil teknolojilere ilişkin ön bilgi düzeyi puanları arasında da anlamlı bir fark olduğu görülmektedir.

ÖNERİLER

Bu araştırmanın çalışma grubunu bir devlet üniversitesinde bulunan eğitim fakültesinde öğrenim gören öğretmen adayları oluşturmaktadır. Bu nedenle, araştırma bulgularının genellenebilmesi için, farklı eğitim fakültelerinde öğrenim gören öğrencilerin de yer aldığı, daha geniş çaplı araştırmalar yapılması önerilmektedir. Ayrıca ileride yapılacak araştırmalarda; farklı eğitim düzeylerindeki öğrencilerin, çeşitli bireysel farklılıklarını da göz önünde bulundurarak, mobil teknolojilere ilişkin ön bilgi düzeylerinin belirlenilmeye çalışılması önerilmektedir.

KAYNAKLAR

- Al-Fahad, F. N. (2009). Students' attitudes and perceptions towards the effectiveness of mobile learning in King Saud University, Saudi Arabia. *The Turkish Online Journal of Educational Technology*, 8(2), 111-119.
- Bulun, M., Gülnar, B., & Güran, S. M. (2004). Eğitimde mobil teknolojiler. *The Turkish Online Journal of Educational Technology (TOJET)*, 3(2), 165-169.
- Geddes, S. J. (2004). Mobile learning in the 21st century: Benefit for learners. *Knowledge Tree e-journal*, 30(3), 214-28.
- Keegan, D. (2005). *Mobile learning: The next generation of learning*. Report, Distance Education International.
- O'Malley, C., Vavoula, G., Glew, J. P., Taylor, J., Sharples, M., Lefrere, P., Lonsdale, P., Naismith, L., & Waycott, J. (2005). WP 4-Pedagogical methodologies and paradigms: Guidelines for learning/teaching/tutoring in a mobile environment. MOBIlearn Project Report, March 29.
- Song, Y. (2011). Investigating undergraduate student mobile device use in context. In A. Kitchenham (Ed.), *Models for interdisciplinary mobile learning: Delivering information to students* (pp. 120-136). Hershey: Information Science Reference (an imprint of IGI Global)
- Stockwell, G. (2007). Vocabulary on the move: Investigating an intelligent mobile phonebased vocabulary tutor. *Computer Assisted Language Learning*, 20(4), 365-383.
- Thornton, P., & Houser, C. (2002). M-learning: Learning in transit. In P. Lewis (Ed.), *The changing face of CALL: A Japanese perspective* (pp. 229-243). Lisse, The Netherlands: Swets & Zeitlinger.
- Uzunboylu, H., Cavus, N., & Ercag, E. (2009). Using mobile learning to increase environmental awareness. *Computers & Education*, 52, 381-389.
- Waycott, J., & Kukulska-Hulme, A. (2003). Students' experiences with PDAs for reading course materials. *Personal and Ubiquitous Computing*, 7(1), 30-43.
- Woodill, G. (2010). *The mobile learning edge: Tools and technologies for developing your teams*. Publisher: McGraw-Hill.

Ek-1

<i>Mobil Teknolojilere İlişkin Ön Bilgi Düzeyi Anketi</i>			
<i>Bu anket mobil teknolojilere ilişkin ön bilgi düzeyinizi belirlemek amacıyla hazırlanmıştır. Aşağıdaki maddelerin doğru ya da yanlış yanıtları yoktur, lütfen maddeleri okuduktan sonra aklınıza gelen ilk yanıtı işaretleyiniz.</i>			
<i>Katılımınız için teşekkürler...</i>			
<i>Bölüm 1. Kişisel Bilgiler</i>			
1. Bölümünüz:			
2. Sınıfınız:			
3. Cinsiyetiniz:	Kadın ()	Erkek ()	
4. Haftalık internet kullanma süreniz:	0-3 saat ()	3-6 saat ()	6-9 saat () 9 saat ve üzeri ()
5. Yandaki mobil cihazlardan hangisine/hangilerine sahipsiniz? (Birden fazla seçim yapabilirsiniz.):	Cep Telefonu () Akıllı Telefon () Dizüstü Bilgisayar () Tablet Bilgisayar ()	PDA (Kişisel Dijital Asistan) () Tablet (iPad, Samsung Tab vb.) () Minibook (Netbook) () Diğer (Lütfen Yazınız.)	
Bölüm 2. Mobil Teknolojilere İlişkin Ön bilgi			
Madde	Evet	Hayır	
6. Mobil cihazları kullanarak, internete nasıl gireceğimi biliyorum.			
7. Mobil cihazları kullanarak, mobil uygulamaları nasıl indireceğimi biliyorum.			
8. Mobil cihazları kullanarak, istediğim bir metni başka bir dile nasıl çevireceğimi biliyorum.			
9. Mobil cihazları kullanarak, nasıl alarm/uyarı notu/hatırlatma			

oluřturacađımı biliyorum.		
10. Mobil cihazları kullanarak, sosyal ađ sitelerine(Facebook, Twitter vb.) nasıl bađlanacađımı biliyorum.		
11. Mobil cihazları kullanarak, nasıl eposta alacađımı/göndereceđimi biliyorum.		
12. Mobil cihazları kullanarak, bir podcasti nasıl indireceđimi biliyorum.		
13. Mobil cihazları kullanarak, nasıl fotođraf/video çekeceđimi biliyorum.		
14. Mobil cihazları kullanarak, nasıl görüntülü görüřme yapacađımı biliyorum.		
15. Mobil cihazları kullanarak, nasıl ses kaydı yapacađımı biliyorum.		
16. Mobil cihazları kullanarak, hesaplama işlemlerini nasıl yapacađımı biliyorum.		

EVALUATING EFFECTS OF AN EXHIBITION VISIT ON PRE-SERVICE ELEMENTARY TEACHERS' UNDERSTANDINGS ON CLIMATE CHANGE

Deniz SARIBAŞ
Istanbul Aydın University
denizsaribas@gmail.com

Zerrin DOĞANÇA
Bogaziçi University
zerrin.doganca@boun.edu.tr

Hamide ERTEPINAR
Istanbul Aydın University

ABSTRACT: This research aims to investigate to what extent a visit to climate change-oriented exhibition embedded within an environmental education course has effects on pre-service elementary teachers' understandings about climate change. Sample of the study includes 58 pre-service teachers, enrolled in Environmental Education course offered in the 2011-2012 academic year in Elementary Education Program at a private university in Turkey. The course lasted 13 weeks and the context is composed of various environmental issues as well as an exhibition visit and student reflections. Pre-service elementary teachers' pre- and post-reflections were analyzed and coded for examining effects of visit on their understandings about climate change. It was found that the course seem to have an impact on pre-service elementary teachers' understanding of climate change. Besides, the exhibition visit resulted in increased understanding in consequences of climate change and the participants were able to make more individual-oriented suggestions for the climate change problem.

Key words: Environmental education, understanding of climate change, pre-service elementary teachers.

INTRODUCTION

Since the planet we inhabit has been facing serious environmental problems, educating environmentally literate citizens becomes increasingly important and therefore, environmental education has taken place in the curricula from early grades to higher grades of education. Besides, there is growing emphasis on the environmental education research. However, the studies investigating effectiveness of teaching programs in terms of students' understandings of environmental problems are rarely found. Although the positive and inevitable outcomes of visits to informal science settings are reported in science education literature (Rickinson et. al., 2004), there are not enough environmental education researches studying effects of visits on visitors' understandings on environmental problems. Investigating pre-service elementary teachers' understanding of environmental problems is significant because they will educate future citizens.

Scientists argue that climate change has negative impacts on human life and natural systems and continuously leads to problems such as droughts, floods, heavy precipitation, diseases, etc. Educating children about climate change can decrease their vulnerability risk as well as it will contribute to their understandings of sustainability on Earth (UNICEF, 2013).

Selection of the theme for the visit was intentional, because climate change is a dynamic and complex problem by its nature. The complexity of climate change stems from long delays between emissions of greenhouse gases (GHGs), their accumulation in atmosphere, their effects to temperature and climate, and eventually insufficient changes in emission policies (Moxnes and Sagsel, 2009). These complexities result in misconceptions about climate change. Even, graduate students from prestigious universities like MIT and Harvard have misconceptions about how GHGs accumulate in atmosphere (Sterman and Sweeney, 2002).

Recent literature often focuses on perceptions, knowledge, and understanding about climate change (Bord, O'Connor, & Fisher, 2000; O'Connor, Bord, & Fisher, 1999), the gap between environmental knowledge, environmental awareness and displaying pro-environmental behavior (Kollmuss & Agyeman, 2002) and the actions people take in order to mitigate the climate change (Whitmarsh, 2009). However, studies searching the impact of a treatment on student learning about climate change are rarely found.

The treatment that might affect learning outcome is chosen as visit because the researches in science education point out the impact of the visits on various learning outcomes. The benefits of the visit to a science center or

museums are reported as making students have fun (Lucas, 2000), fostering knowledge and learning (Bamberger & Tal, 2008), and increased attitudes toward protecting wildlife (Hughes, Packer, & Ballantyne, 2011). However, there are not enough studies investigating the effect of visit to science centers, museums, and etc. on students understanding of climate change.

The study presented here contributes to the environmental education (EE) literature in curricular way. The purpose of this study is to examine to what extent the visit to an exhibition embedded within an environmental education course has effects on pre-service elementary teachers' understandings about climate change. By pointing out this effect, it will be possible to improve environmental education courses at education faculties.

METHOD

Sample

58 students, who enrolled in EE course in Elementary Education Program at a private university in Turkey in the spring semester of 2011-2012, participated in this study. 14% of the participants was male and 86% was female. 71% of the participants specified their hometown as metropolitan, 22% of them specified it as rural area, 3% of them specified it as town and 2% specified it as village while 2% didn't answer this question. Metropolitans let in so many immigrants in recent years in Turkey, so identification may not be sufficient to depict the sample. For this reason, we need to identify the education level of the participants' parents. Regarding the education level of their mothers, 10% of the participants specified the education level of their mothers as university graduate, 31% as high-school graduate, 16% as middle school graduate, 38% as primary-school graduate, and 5% didn't specify at all. Regarding the education level of their fathers, 2% of the participants specified the education level of their fathers as doctorate, 19% of them specified it as university graduate, 39% as high-school graduate, 17% as middle school graduate, and 21% as primary-school graduate, while 2% didn't answer this question.

Research Questions

This paper reports effects of an exhibition visit on pre-service elementary teachers' understanding of climate change. The study presented here addresses the following research questions:

1. To what extent does the exhibition visit embedded within an environmental education program have effects on pre-service elementary teachers' understandings about climate change?
2. Does the EE course have an effect on participants' understandings on climate change?
3. Is there a significant difference of understanding climate change between the students who attended the exhibition and those who did not?

Research Design and Procedure

This research incorporates pre-test-post-test design by collecting pre and post-reflections at the beginning and at the end of the EE course. Quantitative and qualitative analyses were implemented to get deeper insights from the reflections and to make more comprehensive comparisons between pre and post-reflections.

The treatment was implemented in the EE course that lasted 13 weeks. During the first five weeks, basic concepts about ecology and general information about the historical development and the causes of environmental problems were introduced. The following five weeks, the pre-service teacher- groups (with three or four members) made presentations about various current environmental problems listed below:

1. Water pollution,
2. Air pollution,
3. Soil pollution and erosion,
4. Radioactive pollution,
5. The depletion of ozone layer,
6. The loss of biological diversity,
7. Wastes,
8. Energy,
9. Hormone-injected foods and genetically modified organisms, and
10. Global warming.

At the beginning of the term, the pre-service teachers submitted pre-reflections on climate. After the presentations, the participants went to an exhibition about climate change. Participation to exhibition visit was

voluntary, but they were all supposed to submit their post-reflections on climate change at the end of the term. 33 pre-service teachers volunteered to participate the visit, while 25 did not.

INSTRUMENTS

Pre-and post-reflections are the instruments in this study. The reflections were expected to include definition, causes, consequences, and suggestions for possible solutions for climate change. The exhibition visitors were expected to write their impressions about the exhibition including the things that attracted their attention most on their post-reflections. The reflections were coded and evaluated by the first and the second author of this paper. Agreement percentages for each code were calculated and it was found the two experts were in 75-99% range of agreement. After individual assessments, the two raters came together to discuss about the inconsistencies and complete agreement was reached.

RESULTS

The reflections were analyzed under four categories. Specified codes, their frequencies, and percentages within the sample are reported on separate tables for each category. Tables (1-4) are formed to represent the general picture for the categories; definitions, causes, consequences, and suggestions of climate change, respectively. Further statistical analyses are included in the following pages.

Table 1. Frequency distributions for definitions of climate change

		CODES		
		Change	Long-term	Weather Conditions
Pre-Reflection	Frequency	16	6	17
	Percentage (%)	27.5	10.3	29.3
Post-Reflection	Frequency	46	34	47
	Percentage (%)	79.3	58.6	81

The McNemar test was used to analyze the codes emerged from the participants' pre- and post-reflections. This test is used for investigating whether there are significant differences on dichotomous variables for dependent samples (Laerd Statistics, 2013). Table 5 shows the statistically significant results of the change in understanding of climate change of pre-service elementary teachers both who attended the exhibition and those who did not throughout the course at .05 confidence interval. It is found that the EE course results in significant changes in specified categories for both visitors and non-visitors to the exhibitions.

Table 2. Frequency distributions for causes of climate change

		CODES								
		GHGs	Name of GHGs	Source of GHGs	Natural Causes	Deforestation	Industry	Global Warming	Ozone Depletion	Irregular Urbanization
Pre-Ref.	Fre.	31	13	12	4	5	13	10	9	5
	Perc (%)	53.4	22.4	20.6	6.8	8.6	22.4	17.2	15.5	8.6
Post-Ref.	Fre.	51	36	41	24	28	31	6	9	11
	Perc (%)	87.9	62	70.6	41.3	48.2	53.4	10.3	15.5	18.9

Table 3. Frequency distributions for consequences of climate change

		CODES								
		Melting of Glaciers	Rising Sea Level	Global Warming	Droughts	Floods	Famine	Diseases & Deaths	Extinction of Species	Discussion about Turkey
Pre-Ref.	Fre.	18	18	26	24	22	11	18	22	8
	Perc. (%)	31	31	44.8	41.3	37.9	18.9	31	37.9	13.7
Post-Ref.	Fre.	40	38	41	37	33	13	30	34	12
	Perc. (%)	68.9	65.5	70.6	63.7	56.8	22.4	51.7	58.6	20.6

Table 4. Frequency distributions of suggestions for climate change

		CODES						
		Saving Energy	Renew. Energy	Public Transport	Green Buildings	Forestation	Organizations	Waste Management
Pre-Ref.	Fre.	15	7	5	1	11	13	0
	Perc. (%)	25.8	12	8.6	1.7	18.9	22.4	0
Post-Ref.	Fre.	29	38	30	8	28	23	8
	Perc. (%)	50	65.5	51.7	13.7	48.2	46.5	13.7

Two groups were formed according to participation to the exhibition; the visitors groups (n=33) and the non-visitors group (n=25). To make deeper analyses between visitors and non-visitors to the exhibitions, Chi-square test was used to compare the data for each. At the beginning of the course, the number of students who did not attend the exhibition addressed the importance of the role of the organizations, foundations, and governments for the solution of the climate change is significantly higher than those who attended the exhibition ($p < 0.05$) (Table 6). These students might have attributed the solutions of environmental problems on the decisions of organizations, foundations and governments and underestimate individual efforts. This result can be accepted as an indication of their unwillingness to act environmentally. No significant difference was found between the two groups in terms of the other categories ($p > 0.05$).

Table 5. McNemar test results for the reflection categories wrt visitors and non-visitors

		Visitors		Non-Visitors	
		N	Sig. (2-tailed)	N	Sig. (2-tailed)
Definition	Change	33	0.00*	25	0.01*
	Weather conditions	33	0.00*	25	0.01*
	Long period of time	33	0.00*	25	0.00*
Causes	Name of the gases	33	0.00*		

	Sources of the gases	33	0.00*	25	0.02*
	Natural causes	33	0.03*	25	0.00*
	Forest devastation	33	0.01*	25	0.02*
	Industrialization			25	0.03*
Consequences	Glacier melting	33	0.04*		
	Destroying habitats	33	0.02*		
Solutions	Renewable energy	33	0.00*	25	0.01*
	Saving natural sources	33	0.02*		
	Individual efforts	33	0.00*	25	0.00*
	Public transportation	33	0.00*	25	0.04*
	Green buildings	33	0.03*		
	Forestation			25	0.02*
	Organizations			25	0.00*

*p<0.05

Table 7 shows the Chi-square analysis of the categories that emerged from the participants' post-reflections. Pearson chi-square value was used to analyze the data for the categories of the names of the gases and individual efforts. Continuity correction value was utilized to interpret the result of the category of irregular urbanization because observed value was less than 5 in one of the cells in the analysis of this category. Table 7 reveals that the number of the participants who attended the exhibition visit is significantly higher than those who did not in terms of the knowledge of names of the greenhouse gases, and irregular urbanization as a factor affecting climate change and suggesting individual efforts for the solution of this environmental problem.

Table 6. Chi-square test results for pre-reflections between visitors and non-visitors

Pearson Chi-square	Value	df	Asympt. Sig. (2 sided)
Organizations	5.25	1	0.02

Table 7 Chi-square test results for pre-reflections between visitors and non-visitors

Cause – Names of the gases			Cause – Irregular urbanization			Solution – Individual efforts		
Pearson chi-square value	df	Asympt. Sig. (2 sided)	Continuity correction value	df	Asympt. Sig. (2 sided)	Pearson chi-square value	df	Asympt. Sig. (2 sided)
9.54	1	0.00	9.15	1	0.00	4.58	1	0.03

*p<0.05

Insights from the Reflections

Apart from the quantitative findings, the reflections include some invaluable phrases that enable to make comparisons between pre-and post-reflections. Firstly, it should be noted that the pre-service teachers were free to utilize any reliable resources from both internet and books. As indicated with statistical tests, the participants seemed to learn from the EE course and their essays reflect their learning. The pre-reflections include several

direct and in-direct quotations from various resources, while the post-reflections include their own statements with fewer references. The post-reflections of the visitor group especially refer to the exhibition while giving information on climate change.

In addition to selection of references, identification of the four categories is another issue between the pre-and post-reflections. Definitions, causes, consequences, and suggestions can be identified clearly in the post-reflections. This might be another reason for the frequency differences on Table 5. As a complex environmental problem, it is hard to understand the structure of climate change, identify the causes and consequences because they are nested. On post-reflections, there are clear statements like *“Global warming is not a cause, but a consequence of climate change.”* that might represent their understanding about climate change. The terminology they selected changed from the pre- and the post-reflections. Some participants mentioned about GHGs as “harmful gases” on their pre-reflections, while there was no phrase as “harmful gases” on the post-reflections.

The difference between post-reflections of the visitors and non-visitors lies on the suggestions they made. The suggestions of the visitors seem to be diverse and more individual-oriented. They included constructing green buildings, consuming thrifty bulbs, insulation of apartments, consuming less hot water, using non-plastic bags for shopping, consuming less, riding bicycles, and preferring vehicles operating with renewable energy sources. Besides, the case for coral reefs was only mentioned on some of the post-reflections of the visitors. They also mentioned about how they were impressed with the coral reef model at the exhibition. Table 8 represents the attracting themes at the exhibition mentioned by the visitors.

Table 8 Impressions about exhibition

Themes	Visitors (%)
Polar bears	63.64
Models	48.48
Green buildings	18.18
Energy platforms	15.15
Polar fox	12.12
Recycled materials	12.12
CO ₂ graph	9.09
Pressing the button	9.09
Other	33.33
Not identified	12.12

CONCLUSION

Today we all know the fact that EE has a crucial role for educating environmentally literate citizens. For achieving this aim, most of the teacher education curricula have incorporated EE courses into their programs. There is also growing literature in the research on EE. However, there’s also a need of researches investigating the impacts of some methods and activities conducted in EE courses. The study presented here aims to fulfill this requirement.

The results of this study revealed that the EE course, focusing on informing about ecological concepts, presenting and discussing various environmental problems, seem to have an impact on pre-service elementary teachers’ understanding of climate change. The pre-service elementary teachers also seem to have benefited from this course regarding the suggestions for the solutions of the climate change. They seem to have improved their understanding the importance of the usage of renewable energy resources, various individual efforts to be made, and public transportation throughout the course. This result is consistent with the literature emphasizing

impacts of EE on various learning outcomes (Hungerford and Volk, 1990; Grotzer and Basca, 2003; Doğança, 2013).

The most distinctive aspect of the study presented here is organization of an exhibition visit and to ask the volunteer visitors to write reflections after the visit, although all the pre-service elementary teachers wrote reflections before and after the course. Comparison of the reflection of the visitors and non-visitors reveal that the exhibition visit contributes to the increased understanding in terms of naming the greenhouse gases, negative consequences of climate change, such as destroyed habitats, the importance of natural sources, and constructing green buildings for the solution of climate change. Attending exhibition visit also seem to have an impact on the awareness of the negative effect of the irregular urbanization on climate change and the importance of the individual efforts for the solution of this environmental problem.

Another finding of this study was related to attributing solutions of environmental problems to organizations, foundations, and governments. This attribution might have a negative influence on attending informal learning environments, thereby to take an action against any of the environmental problems. For this reason, students' beliefs should also be taken into account for designing EE curricula. Moreover, continuing efforts must be taken to overcome students' negative beliefs for the solution of environmental problems.

The pre-service elementary teachers' reflections indicated that affective content of the representations attracted most of the participants' attention more than the intellectual one. This result can be interpreted that informal learning environments, such as exhibitions presenting models and pictures that create dramatic effect on people can be more instructive than the intellectual ones. This finding can also be explained by the background of the participants of this study. These participants have limited background of science and EE and most of them chose to answer the questions of language and social part of the university entrance exam. These participants' background may have affected the content of the exhibition that attracted their attention. Further study, conducted on different samples and investigating affective outcomes may bring light to this issue.

The data of this study were participants' reflections. Interviews with some of the participants might have brought a deeper insight on their understanding of the climate change. Further research examining the effect of different methods implemented in EE courses on various outcomes in different grade levels is needed.

REFERENCES

- Bamberger, Y., & Tal, T. (2008). An experience for the lifelong journey: The long-term effect of a class visit to a science center. *Visitor Studies, 11*(2), 198-212.
- Bord, R. J., O'Conner, R. E., & Fisher, A. (2000). In what sense does the public need to understand global climate change? *Public Understanding of Science, 9*, 205-218.
- Doğança, Z. (2013). Designing system-based environmental instruction program and evaluating its effects on seventh grade students. Unpublished PhD Dissertation, Bogazici University, Istanbul.
- Grotzer, T. A. , Basca, B. B., 2003. How does grasping the underlying causal structures of ecosystems impact students' understanding? *Journal of Biological Education, 38*(1), 16-29.
- Hughes, K., Packer, J., & Ballantyne, R. (2011). *Environmental Education Research, 17*(3), 307-328.
- Hungerford, H. R., Volk, T. L., 1990. Changing learner behaviour through environmental education. *Journal of Environmental Education, 21* (3), 8-21.
- Kollmuss, A., & Agyeman, J. (2002). Mind the gap: why do people environmentally and what are the barriers to pro-environmental behaviors? *Environmental Education Research, 8*(3), 239-260.
- Laerd (2013). Retrieved from <https://statistics.laerd.com/spss-tutorials/mcnemars-test-using-spss-statistics.php>
- Lucas, K. B. (2000). One teacher's agenda for a class visit to an interactive science center. *Science Education, 84*, 524-544.
- Moxnes, E. & Saysel, A. K., 2009. Misperceptions of global climate change: information policies. *Climate Change, 93*; 15-37.
- O'Conner, R. E., Bord, R. J., & Fisher, A. (1999). Risk perceptions, general environmental beliefs, and willingness to address climate change. *Risk Analysis, 3*, 461-471.
- Rickinson, M., Dillon, J., Teamy, K., Morris, M., Young Choi, M., Sanders, D.,&Benefield, P. (2004). *A review of research on outdoor learning*. Shrewsbury, England National Foundation of Educational Research.

Sterman, J. D., Sweeney, L. B., 2002. Cloudy skies: assessing public understanding of global warming. *System Dynamics Review*, 18, 2, 207- 240.

UNICEF (2013). Retrieved from http://www.unicef.org/education/bege_61668.html

Whitmarsh, L. (2009). Behavioural responses to climate change: Asymmetry of intentions and impacts. *Journal of Environmental Psychology*, 29, 13-23.

UZAKTAN EĞİTİMDE ÇEVİRİMİÇİ DERS İÇİN BİR YOKLAMA SİSTEMİNİN TASARIMI

AN ATTENDANCE SYSTEM DESIGN FOR ONLINE COURSES IN DISTANCE EDUCATION

Sultan ZAVRAK
Düzce Üniversitesi
sultanzavrak@duzce.edu.tr

Mehmet Emin SALMAN
Sakarya Üniversitesi
mesa1431@gmail.com

Özdemir ÇETİN
Sakarya Üniversitesi
ocetin@sakarya.edu.tr

ÖZET: Uzaktan eğitim, son zamanlarda birçok eğitim kurumu veya üniversite tarafından öğrencilere sunulan bir öğretim şeklidir. Teknolojinin gelişmesiyle ortaya çıkan bu eğitim şekli, örgün eğitimde karşılaşılan eğitim mekanının sabit kalması, uzakta olan öğrencilerin ulaşım zorluğu, eğitici sayısının sınırlı olması ve öğretim kaynaklarının yetersiz olması gibi nedenlerden dolayı popülerlik kazanmıştır. Uzaktan eğitim şeklinin faydalarının yanında bazı dezavantajları bulunmaktadır. Bu dezavantajlardan biri öğrencilerin çevrimiçi ders sırasında derse giriş yaptıktan sonra bilgisayarının başından ayrılması ve bu aralıkta ders veren öğreticinin bu durumdan geç haberdar olması veya hiç haberdar olamamasıdır. Bu çalışmada, bu tip durumları takip eden ve kayıt altına alan bir yoklama sistemi tasarımı önerilmektedir. Bu sistemde öğrencinin çevrimiçi ders sırasında, bilgisayarında dersi dinleyip dinlemediği bir kamera vasıtasıyla alınan görüntülerden anlaşılabilir ve görüntülerin sadece dersi alan kişiye ait olup olmadığı bir yüz tanıma yazılımıyla sağlanmaktadır. Bu şekilde gerçekte öğrencinin dersi dinleyip dinlemediği anlaşılabilir derse devam-devamsızlık durumu daha net bir şekilde kaydedilebilmektedir.

Anahtar sözcükler: uzaktan eğitim, çevrimiçi ders, yoklama sistemi, yüz tanıma.

ABSTRACT: Distance education is a form of teaching offered to students by many educational institutions or universities in these days. With the development of technology, this emerging form of education has gained popularity because of the reasons such as constant training venues encountered in formal education, transportation challenges of remote students, limited number of educators and inadequate teaching resources. Besides the benefits of distance learning, it has some disadvantages. One of these disadvantages, after the students logged in the system, they leave the computer during the online course and the instructor becomes aware late or doesn't. In this study, it is proposed design of an attendance system which tracks and records this type of situations. In this system, the student is listening or not is detected from the images taken by a camera and with a face-recognition software, it is provided the images belong to student or not. In this way, the student's course attendance-absence status can be recorded in a clearer way with detection of that the students are actually listening or not.

Key words: remote education, online course, attendance system, face recognition.

GİRİŞ

Uzaktan eğitim (Moore, 2013; Willis, 1993), son zamanlarda birçok eğitim kurumu veya üniversite tarafından öğrencilere sunulan bir öğretim şeklidir. Teknolojinin gelişmesiyle ortaya çıkan bu eğitim şekli, örgün eğitimde karşılaşılan eğitim mekanının sabit kalması, uzakta olan öğrencilerin ulaşım zorluğu, eğitici sayısının sınırlı olması ve öğretim kaynaklarının yetersiz olması gibi nedenlerden dolayı popülerlik kazanmıştır (Yavuz BAYAM, 2002). Uzaktan eğitim şeklinin faydalarının yanında bazı dezavantajları bulunmaktadır. Bu dezavantajlardan biri öğrencilerin çevrimiçi ders sırasında derse giriş yaptıktan sonra bilgisayarının başından ayrılması ve bu aralıkta ders veren öğreticinin bu durumdan geç haberdar olması veya hiç haberdar olamamasıdır. Bu durumda gerçekte öğrencinin dersi dinleyip dinlemediği anlaşılabilir derse devam-devamsızlık durumu daha net bir şekilde kaydedilebilmektedir.

Bu çalışmada, bu tip durumları takip eden ve kayıt altına alan bir yoklama sistemi tasarımı önerilmektedir. Bu sistemde öğrencinin çevrimiçi ders sırasında, bilgisayarında dersi dinleyip dinlemediği bir kamera vasıtasıyla

alınan görüntülerden anlaşılma ve görüntülerin sadece dersi alan kişiye ait olup olmadığı bir yüz tanıma yazılımıyla sağlanmaktadır. Bu şekilde gerçekte öğrencinin dersi dinleyip dinlemediği anlaşılabilir. Bu durum devamsızlık durumu daha net bir şekilde anlaşılabilir.

SİSTEM TASARIMI

Uzaktan eğitim sisteminde çevrimiçi dersler yapılırken bir senkron iletişim aracı olan kamera kullanılmakta ve öğrenci-öğretmen arasındaki iletişim rahatlıkla sağlanmaktadır (M. Hakan Çetiner, 1999). Şekil 1’de bir uzaktan eğitim sisteminin genel yapısı verilmektedir. Bu sistemde öğrenciler ve öğretmenler sisteme internet üzerinden bağlanabilmektedir. Kayıtlı oldukları kurum veya üniversite tarafından kendilerine sağlanan kullanıcı adı ve şifrelerle sisteme giriş yaptıktan sonra açık veya aktif olan derslere rahatlıkla erişebilmektedir. Çevrimiçi sunulan derste, öğretmenin veya öğreticinin kişisel bilgisayarına bağlı olan kameradan alınan görüntüyü o anki derse katılan tüm öğrencilere eş zamanlı olarak gönderilmektedir. Ayrıca derse katılmış olan öğrencinin bilgisayarına bağlı kameradan da diğer kullanıcılara görüntü aktarımı yapılabilmektedir.

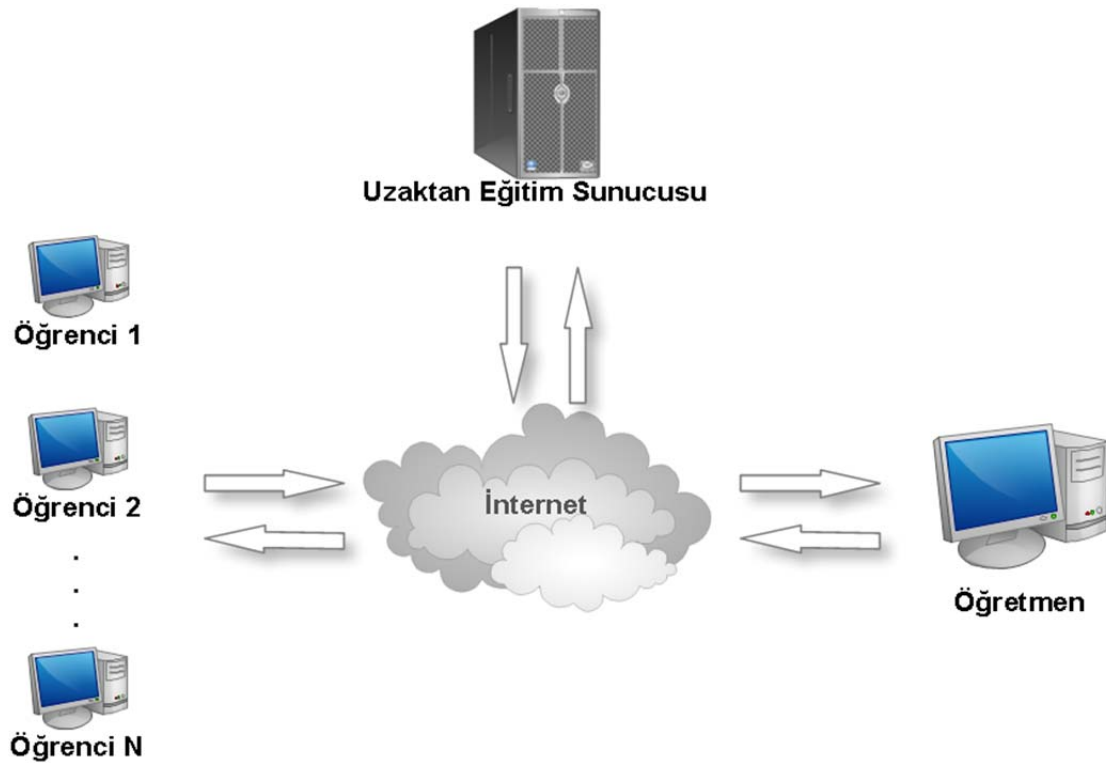

Şekil 1. Uzaktan Eğitim Sistemi Genel Diyagramı

Uzaktan eğitim sisteminde çevrimiçi derse katılan bir öğrenci, dersi anlatan öğretmeni dinlerken öğretmenin kamerasından kendi kişisel bilgisayarına uzaktan eğitim sunucusu vasıtasıyla aktarılan görüntü dizisini yani videoyu görmektedir. Bu sistemin bir eksiği, öğrencinin bilgisayarın karşısından ayrılması, öğretmen kontrol etmediği takdirde anlamamaktadır. Var olan bu eksiklik, sistem kullanıcılarında hazır halde bulunan kameraların kullanılmasıyla öğrencilerin bilgisayarlarından belirli zaman aralıklarında alınacak görüntülerle giderilebilir. Bu görüntülerde, öğrencinin yüzünün olması gerekmekte aksi halde sistem çalışmayacaktır.

Yüz Tanıma Tabanlı Yoklama Modülü

Yüz tanıma, birçok sistemde kullanılan ve son zamanlarda artık kişisel bilgisayarlarda da kullanılan yaygın bir biyometrik tanıma şeklidir (Wechsler & Division, 1998; Zhao, Chellappa, Phillips, & Rosenfeld, 2003). Bu tanıma çeşidinde her kişiye özgü olan insan yüzü kullanılmakta ve sonuç olarak gerçekte bu kişinin doğru kişi olup olmadığı veri tabanına bakılarak tespit edilebilmektedir.

Şekil-2’den de anlaşılacağı üzere şu anda kullanılan uzaktan eğitim sistemlerine ekstra bir donanım alınmadan ve sadece yüz tanıma özelliği içeren bir yoklama modülü yazılımı eklenerek rahatlıkla öğrencilerin gerçekte derse katılıp katılmadığı anlaşılabilir.

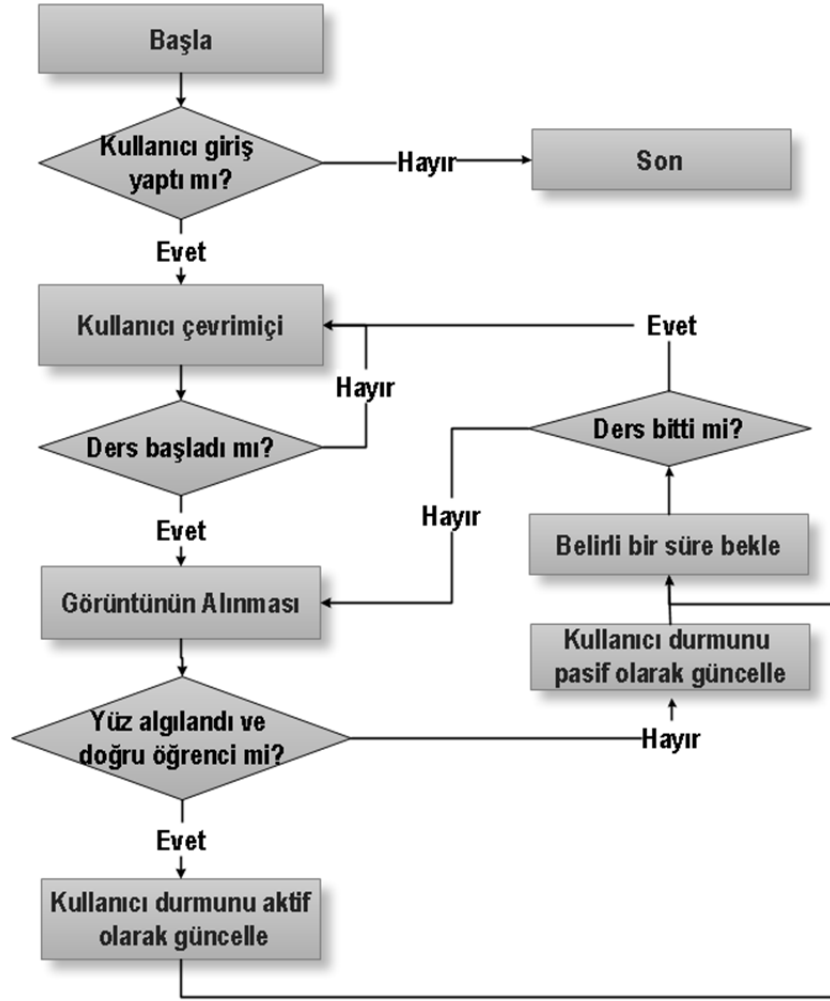

Şekil 2. Yüz Tanıma Tabanlı Yoklama Sistemi Algoritması

Yüz tanıma tabanlı yoklama sisteminde, başlangıç olarak uzaktan eğitim sistemine kayıt olan öğrencilerin yüz resimlerinden (vesikalık resim) sisteme kayıt oluşturulur. Uzaktan eğitime kayıt aşamasında öğrenci yüz resimleri öğrencilerden alınmakta ve ilave bir işlem gerekmemektedir. İleride sorgulanmak üzere yüz resimlerinden kayıtların oluşturulması, sistemi geliştirenlerin kullandığı bir yüz tanıma algoritmasına göre yapılmaktadır. Seçilen yüz tanıma algoritması, sistemin çalışmasında önemli rol oynamaktadır. Çünkü gerçekte derse katılan kişiyi sistem yanlış kişi olarak algılasa öğrencinin derse katılmadığı kayıtlara işlenecektir.

Yüz tanıma algoritması seçilirken dikkat edilmesi gereken ikinci bir kısım ise algoritmanın gerçek zamanlı (Nasrollahi & Moeslund, 2013; Shou-Jen, Chao-Yang, Mei-Hsuan, Chi-Sen, & Chu-Sing, 2010) çalışabilir olmasıdır. Yüz tanıma bir kişi için belirli zaman aralıklarında yapılması önerilse de aynı anda sunulan birçok derse katılmış çok sayıda kişide yüz tanınması yapılması gerekecektir. Görüntülerin öğrenci bilgisayarlarından alınması zaman aralığı, sistem yöneticileri tarafından sistemin genel yüküne bağlı olarak değiştirilebilmesi gerekir.

SONUÇ

Yapılan bu çalışmada, uzaktan eğitim sistemde çevrimiçi derslerde kullanılmak üzere bir yoklama sistemi önerilmektedir. Bu sistemde teknolojinin gelişmesiyle yaygınlaşan bir biyometrik tanıma çeşidi olan yüz tanıma kullanılması önerilmektedir. Bu biyometrik tanımanın seçilmesinin nedeni, uzaktan eğitime kayıtlı öğrencilerde kameranın olması, uzaktan eğitime kayıt sırasında yüz resimlerinin alınması, yüz tanıma başarı oranının yüksek olması, gerçek-zamanlı çalışabilmesi ve şu anda çalışan sistemlere kolay entegre edilebilir olması şeklinde sıralanabilir.

KAYNAKLAR

- M. Hakan Çetiner, Ç. G., Y. Murat Erten. (1999). *İnternete Dayalı Uzaktan Eğitim ve Çoklu Ortam Uygulamaları*. Paper presented at the V."Türkiye'de İnternet" Konferansı Ankara Üniversitesi Tıp Fakültesi, Ankara.
- Moore, M. G. (2013). *Handbook of Distance Education*: Taylor & Francis.
- Nasrollahi, K., & Moeslund, T. B. (2013, 15-18 Sept. 2013). *Haar-like features for robust real-time face recognition*. Paper presented at the Image Processing (ICIP), 2013 20th IEEE International Conference on.
- Shou-Jen, L., Chao-Yang, L., Mei-Hsuan, C., Chi-Sen, C., & Chu-Sing, Y. (2010, 11-14 July 2010). *The study and implementation of real-time face recognition and tracking system*. Paper presented at the Machine Learning and Cybernetics (ICMLC), 2010 International Conference on.
- Wechsler, H., & Division, N. A. T. O. S. A. (1998). *Face recognition: from theory to applications*: Springer.
- Willis, B. (1993). *Distance Education: A Practical Guide*: Educational Technology Publications.
- Yavuz BAYAM, M. U. (2002). *UZAKTAN EĞİTİMDE ÖĞRENCİ TAKİBİ VE DEĞERLENDİRMESİ*. Paper presented at the AÇIK VE UZAKTAN EĞİTİM SEMPOZYUMU.
- Zhao, W., Chellappa, R., Phillips, P. J., & Rosenfeld, A. (2003). Face recognition: A literature survey. *ACM Comput. Surv.*, 35(4), 399-458. doi: 10.1145/954339.954342

ÖĞRETMEN ADAYLARININ MATEMATİK ÖĞRETİMİNDE KENDİLERİNE REHBER EDİNDİKLERİ ÖĞRETİM MODELLERİ

TEACHING MODELS PROSPECTIVE MIDDLE SCHOOL TEACHERS USE AS GUIDES IN MATHEMATICS TEACHING

İsmail Özgür ZEMBAT
Mevlana Üniversitesi
iozembat@mevlana.edu.tr

Mustafa ASLAN
Selçuklu Abdullah Aymaz Ortaokulu
mustafaalper_aslan@hotmail.com

ÖZET: Bu çalışmanın amacı ilköğretim matematik öğretmen adaylarının matematik öğretimine dair etkisinde kaldıkları matematik öğretim modellerini tespit ve teşhir etmektir. Araştırma Türkiye’de İç Anadolu bölgesindeki bir üniversitenin ilköğretim matematik öğretmenliği bölümünün 3. sınıfında okumakta olan öğretmen adayları üzerinde yapılmıştır. Araştırma esnasında öğretmen adayları matematiği, eğitimi ve öğretimini bir bütün şeklinde ele alan ve doktoralı bir matematik eğitimcisi tarafından verilmekte olan Özel Öğretim Yöntemleri adlı bir derse kayıtlı olup bu derste matematik öğretimine dair zengin içerikli deneyimler kazanmışlardır. Dersler esnasında öğretmen adaylarına literatürden hareketle yapılandırmacı kuramın gereklilikleri dikkate alınarak hazırlanmış etkinlik temelli denk kesirler konusuna dair hazır bir ders uygulanmış ve bu dersin sınıf içinde nasıl şekillenip ortaokul öğrencilerince nasıl yapılandırılabilceği üzerinde analiz yapmaları sağlanmıştır. Sonrasında öğretmen adaylarından bu dersi kendilerinin gerçek birer ortaokul öğrencisi bularak bu öğrenci üzerinde uygulamaları istenmiştir. Bu uygulamalar kendilerince videoya çekilmiş ve toplamda 20 öğretim videosu elde edilmiştir. Yapılan içerik analizinde matematik öğretimi esnasında öğretmen adaylarının referans aldıkları öğretim modelleri, kullandıkları sorgulama çeşitleri, öğretime dair yaptıkları yaygın hatalar ve eğitim ve öğretime bakış açıları üzerine yoğunlaşmaktadır. Yapılan ilk fasıl incelemelerde öğretmen adaylarının benimsedikleri öğretim modellerinin öğretimlerini ciddi anlamda yönlendirdiği görülmüştür.

Anahtar sözcükler: matematik öğretim modeli, öğretmen adayları, yapılandırmacılık

ABSTRACT: The purpose of this research is to determine the mathematics teaching models under the influence of which the prospective middle school teachers work. The research was conducted on third year prospective middle school mathematics teachers from a university in Anatolia, Turkey. During the investigation the participants were registered to a Mathematics Methods course focusing on mathematics, its learning and its teaching that was taught by a PhD mathematics educator and in which they gain rich experiences about mathematics teaching. During the course the participants were exposed to a set of classes about teaching equivalent fractions that was designed by considering the constructivist principles. They were also given opportunities to reflect on and analyze how such classes play out in a regular classroom and how students might construct the targeted ideas. Then the participants were asked to find a middle school student and apply equivalent-fractions class on that student. These applications were videotaped by each participant and we gathered 20 such videos. In analyzing the data we focus on the kind of teaching models the participants use as a guide in their teaching, the questioning strategies they use, common mistakes they make, and perspectives they adopt for teaching and learning. As a result of the first phase analysis we found that the kind of teaching models the participants adopt seriously guide their teaching.

Key words: mathematics teaching models, prospective middle school teachers, constructivism

ASSESSING STUDENT LEARNING OUTCOMES THROUGH TECHNOLOGY

Bilge SULAK

Sema SULAK

Expected student behaviors are anticipated to be different as a result of education. Especially in outcome-based education, learning outcomes is a product of the education process. Outcome-based education (OBE) is a widely accepted educational approach from elementary school to higher education. The questions “What are some traits of a successful educator?”, “What kinds of educators will the training produce?”, “How competent will educators-in-training be as a result of the training?” are some of the questions that are tried to be answered. It can be attributable that it is challenging to assess student learning outcomes. Student learning outcomes explore the effects of the education on the student, and how they are different as a result of interacting with the program. There is a need to have a comprehensive assessment model to evaluate competence because each individual has a different development level. In literature there is a big gap concerning how to assess student learning outcomes as well as lack of reliable and valid assessment methods. Hence, this paper aims to offer a systemic framework for student learning outcomes and their assessment. Further this paper will provide an overview for benefits of utilizing technology as well as several innovative techniques can be used during assessment phase.

Keywords: student learning outcomes, technology, assessment

ÖĞRETMENLERİN TEKNOLOJİK PEDAGOJİK ALAN BİLGİLERİNİN İNCELENMESİ

INVESTIGATION OF TEACHERS' TECHNOLOGICAL PEDAGOGICAL CONTENT KNOWLEDGE

Cemal Hakan DİKMEN
Öğr. Gör., Afyon Kocatepe Üniversitesi
c.hakan.dikmen@gmail.com

Veysel DEMİRER
Yrd. Doç. Dr., Süleyman Demirel Üniversitesi
veyseldemirer@gmail.com

Halit ARSLAN
Öğretmen, MEB
arslanhalit@gmail.com

ÖZET: Teknolojinin hızla ilerlemesiyle birlikte, bilgi ve iletişim teknolojilerinin hayatımızın her alanında önemli bir yer tuttuğunu söyleyebiliriz. Bu nedenle bilgi ve iletişim teknolojilerinin eğitime entegrasyonunu sağlamak için dünyada ve ülkemizde çalışmalar yapılmaktadır. Bu çalışmaların donanım, alt yapı hizmetleri, içerik, öğretim programları, teknoloji bilinci, hizmet içi eğitimler gibi birçok boyutu olmasına rağmen, en önemli boyutu eğitimde teknoloji entegrasyonunu sağlamada kilit rol üstlenen öğretmenler ve onların eğitime teknoloji entegrasyonundaki bilgi ve becerileridir. Bu bağlamda öğretmenlerin teknolojik pedagojik alan bilgileri (TPAB), eğitime teknoloji entegrasyonunda önemli bir yer tutmaktadır. Bu alanda yapılan çeşitli çalışmalara baktığımızda TPAB yüksek olan öğretmenlerin, eğitime teknoloji entegrasyonunda diğer öğretmenlere oranla daha başarılı olduğu görülmektedir. Bu nedenle bu araştırmada öğretmenlerin TPAB çeşitli değişkenler açısından incelenecektir. Bu amaçla veri toplama aracı olarak Sahin'in (2011) geliştirmiş olduğu "Öğretmenlerin Teknolojik Pedagojik Alan Bilgisi Ölçeği" kullanılmıştır. Öğretmenlerden elde edilen veriler bu amaçlar doğrultusunda analiz edilerek, bulgular eğitime teknoloji entegrasyonu boyutunda tartışılmıştır.

Anahtar Kelimeler: Öğretmenler, Teknolojik Pedagojik Alan Bilgisi, Eğitime Teknoloji Entegrasyonu

ABSTRACT: It can be said that ICT have an important place in every area of our lives with the rapid advancement of technology. Therefore, studies are done in our country and around the world to ensure the education integration of information and communication technologies. Although these studies have many dimensions as the hardware, infrastructure services, content, education programs, technology awareness, in-service training, the most important aspect of the study is that the teachers play a key role in ensuring the integration of technology in education, and their knowledge and skills have a great importance in technology integration in education. In this context, teachers' technological pedagogical content knowledge (TPACK) has a great importance in the integration of technology in education. When we look at the various studies done in this area, teachers with a high TPACK are seen to be more successful than other teachers in the context of the integration of technology in education. Therefore, in this study, teachers' TPACK will be examined in terms of several variables. As data collection tool for this purpose, "Teachers' Technological Pedagogical Content Knowledge Scale" which was developed by Sahin (2011) is used. By analyzing data obtained from teachers for these purposes, results were discussed in terms of technology integration in education.

Keywords: Teachers, Technological Pedagogical Content Knowledge, Technology Integration in Education

GİRİŞ

Teknolojinin hızla ilerlemesiyle birlikte, bilgi ve iletişim teknolojilerinin hayatımızın her alanında önemli bir yer tuttuğunu söyleyebiliriz. Bilgi ve iletişim teknolojilerinin toplumun hemen hemen her alanını etkilemesine rağmen, eğitim uygulamalarına entegrasyonu tam olarak sağlanamadığından (Wang, 2009), çeşitli ülkelerde eğitime teknoloji entegrasyonunun artırılması için çalışmalar yapılmaktadır. Türkiye'de de Milli Eğitim Bakanlığı (MEB) 2010 yılında; sınıflarda teknolojinin etkin kullanılmasıyla öğrenci başarısını arttırmayı hedefleyen Fırsatları Arttırma Teknolojiyi İyileştirme Hareketi (FATİH) projesini duyurmuştur (Demirer, Saban, Küçük, & Şahin, 2011; Kayaduman, Sırakaya & Seferoğlu, 2011).

Ferdig (2006), eğitime teknolojik yenilik getirme konusunu sorgulamış ve iyi bir yeniliğin pedagoji, insan ve performans boyutlarını içerdiğini savunmuştur. Eğitime teknoloji entegrasyonunu sağlamada sadece teknolojiyi

tanıtmanın yeterli olmadığı (Koehler & Mishra, 2005) tam aksine, öğretmenlerin teknolojiyi kullanma şeklinin eğitimi değiştirme potansiyeline sahip olduğunun farkına varılmıştır (Carr, Jonassen, Litzinger, & Marra, 1998). Bu bağlamda eğitime teknoloji entegrasyonunda öğretmen yeterliliklerini yeniden şekillendiren Mishra ve Koehler (2005), Shulman'ın (1987) öğretmen yeterliliklerine kazandırdığı pedagojik alan bilgisi kavramına, teknolojik bilgi kavramını da dahil ederek Teknolojik Pedagojik Alan Bilgisi (TPAB) çerçevesini oluşturmuşlardır.

Teknolojik pedagojik alan bilgisi; alan, pedagoji ve teknoloji bilgisinin etkileşiminden ortaya çıkan anlayışla ilgili bilgidir. Öğretimin etkinliği için teknolojik pedagojik alan bilgisinin bu üç temel kaynağı arasındaki karmaşık etkileşimlerle ilgili bir anlayış geliştirmek gerekmektedir (Kereluik, Mishra, & Koehler, 2011). Öğretmenler ders anlatırken; teknoloji, pedagoji ve alan bilgisini eş zamanlı olarak bütünleştirerek, teknolojik pedagojik alan bilgilerini ortaya koymaktadırlar. Bu nedenle öğretmenlerin ders sırasında karşılaştığı her durum, bu üç faktörün eşsiz kombinasyonudur ve buna göre her öğretmen, her ders veya her öğretim görüşü için tek bir çözüm yolu olmamaktadır. Bunun tam aksine olası çözüm yolları; öğretmenin, teknoloji, pedagoji ve alan bilgisi olarak tanımlanan üç bileşenin ve bunların belirli bağlamlardaki karmaşık etkileşimlerinin arasındaki ilişkileri esneklikle çözebilme yeteneğine bağlıdır. Bu nedenle öğretmenlerin sadece bu üç yönde değil, bunların arasındaki etkileşim durumları hakkında da kendilerini geliştirmeleri gerekir (Koehler & Mishra, 2009). Böylece öğretmenler kendi eğitsel alanını, pedagojik ve teknolojik ortamına uyarlayabilir (Kereluik, Mishra, & Koehler, 2011).

Teknolojik pedagojik alan bilgisi ile ilgili yapılan çalışmalara bakıldığında, öğretmenlerden çok, öğretmen adaylarının teknolojik pedagojik alan bilgilerine yönelik çalışmaların yer aldığı görülmektedir (Akyüz, Pektaş, Kumaz, & Memiş, 2014; Özgen, Narlı, & Alkan, 2013; Pamuk, Ülken, & Dilek, 2012). Diğer eğitime teknoloji entegrasyonu hareketlerinde olduğu gibi FATİH projesi'nin temelinde de bu işin uygulayıcıları olan öğretmenlerin yer aldığı yadsınmaz bir gerçektir (Demirer vd., 2011). Bununla birlikte projenin uygulayıcıları olan öğretmenlerin teknolojik pedagojik alan bilgisi (TPAB) düzeylerinin FATİH projesi'nin sürdürülebilirliğinde önemli bir rolü olacaktır. Bu nedenle bu çalışmada öğretmenlerin teknolojik pedagojik alan bilgilerinin ortaya konulması ve çeşitli değişkenler açısından incelenmesi amaçlanmıştır.

YÖNTEM

Öğretmenlerin TPAB'lerinin inceleneceği bu araştırma tarama modeline göre desenlenmiştir. Araştırmada örneklem grubunun özellikleri, kullanılan ölçme aracı ve veri analiz işlemleri bu bölümde belirtilmiştir.

Evren ve Örneklem

Araştırmanın evrenini ilkökul, ortaokul ve lisede görev yapan öğretmenler oluşturmaktadır. Evrendekilerin tamamına erişmek mümkün olmadığından evreni temsil eden kolay ulaşılabilir örnekleme ile öğretmenlerden veri toplanmıştır. Araştırmaya Afyonkarahisar, Aksaray ve Isparta illerinden toplam 256 öğretmen katılmıştır. Normallik ve uç değer analizleri sonunda veri setinden 14 veri atılmış ve toplamda 242 tane öğretmenin verisi analiz edilmiştir.

Veri Toplama Aracı

Veri toplama aracı olarak Sahin'in (2011) geliştirmiş olduğu "Öğretmenlerin Teknolojik Pedagojik Alan Bilgisi Ölçeği" ile birlikte bireysel bilgi formu ve likert tipinde bir soru uygulanmıştır. TPAB ölçeği yedi alt boyut (TB, PB, AB, TPB, TAB, PAB ve TPAB) ve 47 maddeden oluşmaktadır. Her bir alt boyuttan alınan yüksek puan, söz konusu bilginin uygulanmasına yönelik yüksek algıyı belirtmektedir. Likert tipindeki ölçeğin seçenekleri ise şu şekilde sıralanmıştır: (1) Hiç bilmiyorum, (2) Az düzeyde biliyorum, (3) Orta düzeyde biliyorum, (4) İyi düzeyde biliyorum, (5) Çok iyi düzeyde biliyorum. Bu çalışmada ölçeğin alt boyutlarının Cronbach alfa güvenirlik katsayıları 0.88 ve 0.97 arasında değiştiği belirlenmiştir. Kişisel bilgi formunda öğretmenlerin derslerinde bilişim teknolojilerini kullanım sıklıklarına ilişkin bilgiler sorulmuştur. Ayrıca öğretmenlere derslerinde bilişim teknolojilerini kullanım sıklıklarını belirlemek amacıyla Likert tipinde bir soru yöneltilmiştir. Soru, "Sınıfınızda/derste öğretim amacıyla bilişim teknolojilerini kullanıyor musunuz? şeklinde sorulmuş ve seçenekleri "hiç, nadiren, bazen, sık sık, her zaman" olarak belirlenmiştir.

Veri Analizi

Öğretmen adaylarının TPAB puanlarına yönelik elde edilen verilerin analizinde, frekans, yüzde ve ortalama gibi betimsel istatistikler kullanılmıştır. Ayrıca, TPAB ölçeği alt boyut puanlarının, değişkenlere göre anlamlı farklılık gösterip göstermediğini belirlemek için çok değişkenli varyans analizi (MANOVA) gerçekleştirilmiştir. Sonuçların istatistiksel olarak anlamlı çıkması durumunda, farklılığın hangi gruplardan kaynaklandığını tespit etmek amacıyla, çoklu karşılaştırma testlerinden Bonferroni testi kullanılmıştır. Analizler öncesinde

MANOVA'nın varsayımları test edilmiştir. Öncelikle tek değişkenli ve çok değişkenli uç değerler belirlenerek veri setinden atılmış, varyansların homojenliği için Levene testi, varyans-kovaryans matrislerinin homojenliği için ise Box's M testi kullanılmıştır.

BULGULAR

Öğretmenlerin teknolojik pedagojik alan bilgileri boyutlarında hangi düzeyde olduklarını belirtmek amacıyla, her bir boyuta ait istatistiksel bilgiler Tablo 1'de sunulmuştur.

Tablo 1. TPAB boyutlarına ilişkin istatistiksel bilgiler

	\bar{X}	Ss	En Düşük	En Yüksek	Ranj	Çarpıklık	Basıklık
TB	55.74	12.753	19	75	56	-0.160	-0.724
PB	22.82	3.516	12	30	18	-0.285	0.107
AB	23.55	3.837	13	30	17	-0.349	-0.389
TPB	15.48	2.590	9	20	11	-0.219	-0.434
TAB	14.85	2.808	7	20	13	-0.210	-0.208
PAB	27.25	4.163	14	35	21	-0.281	-0.100
TPAB	19.09	3.303	11	25	14	-0.208	-0.428

Ölçeğin boyutlarına ait istatistiklere bakıldığında, öğretmenlerin bilgi düzeyleri arasındaki farklılıkların TB düzeyinde ($\bar{X} = 55.74$, $Ss = 12.75$) en yüksek, TPB düzeyinde ($\bar{X} = 15.48$, $Ss = 2.59$) en düşük olduğu; ortalama puanlara bakıldığında ise öğretmenlerin bilgi düzeylerinin tamamının ölçekten alınabilecek en yüksek ve en düşük puanlara göre ortalamanın üzerinde olduğu görülmektedir. Öğretmenlerin TPAB'ın boyutları arasında AB düzeylerinin en yüksek, TAB düzeylerinin en düşük olduğu görülmektedir. Bu sonuçlara bakarak öğretmenlerin alan bilgilerinin iyi düzeyde olmasına rağmen, alan bilgilerini teknolojiye entegre etme konusunda aynı düzeyde yeterli olmadıkları söylenebilir.

Cinsiyete Göre Öğretmenlerin Teknolojik Pedagojik Alan Bilgileri

Öğretmenlerin TB, PB, AB, TPB, TAB, PAB ve TPAB düzeylerini cinsiyetlerine göre kıyaslamak için tek faktörlü MANOVA analizi yapılmıştır. Öğretmenlerin cinsiyetlerine göre TPAB boyutlarına ait puanların bütüncül olarak anlamlı bir farklılık gösterdiği sonucuna ulaşılmıştır (Wilk's Lambda = 0.91, $F_{[7-234]}=3.19$, $\eta^2=0.09$, $p < 0.01$). Her bir değişken için tek yönlü ANOVA sonuçlarına bakıldığında, öğretmenlerin teknolojik bilgi ($F_{[1-240]} = 6.01$, $\eta^2 = 0.02$, $p < 0.05$) ve pedagojik alan bilgisi düzeylerinde ($F_{[1-240]} = 5.02$, $\eta^2 = 0.02$, $p < 0.05$) cinsiyete göre anlamlı farklılık bulunmuştur. Erkeklerin ($\bar{X} = 57.47$, $Ss = 13.15$) teknolojik bilgi düzeyleri, kadınlara ($\bar{X} = 53.45$, $Ss = 11.89$) göre daha yüksektir; kadınların pedagojik alan bilgi düzeyleri ($\bar{X} = 27.93$, $Ss = 3.85$), erkeklerden ($\bar{X} = 26.73$, $Ss = 4.33$) yüksektir. Ancak cinsiyetin teknolojik bilgi ve pedagojik alan bilgisi düzeyleri üzerinde etkisi çok düşük olup toplam varyansın sadece %2'sini açıklamaktadır. Cinsiyetin, öğretmenlerin TPAB düzeylerine etkisini araştıran çalışmaların genelinde çoğu bilgi düzeyinde erkeklerin, kadınlara oranla bilgi düzeylerinin daha yüksek olduğu (Erdogan & Sahin, 2010; Jang & Tsai, 2013; Koh, Chai & Tsai, 2014) bulunmasına rağmen; Kazu ve Erten (2014), kadınların pedagojik ve teknolojik pedagojik bilgi düzeylerinin, erkeklerin pedagojik ve teknolojik pedagojik bilgi düzeylerinden daha yüksek olduğunu tespit etmiştir. Lin, Tsai, Chai ve Lee (2013) erkeklerin teknolojik bilgi düzeylerinin kadınlardan, kadınların pedagojik bilgi düzeyinin ise erkeklerden yüksek olduğunu tespit etmiştir. Jang ve Tsai (2012) ise cinsiyetin TPAB düzeyleri üzerinde herhangi bir etkisinin olmadığını belirtmiştir. Cinsiyetin TPAB'ın farklı düzeyleri üzerindeki etkilerini gösteren farklı çalışmalar bulunmasına rağmen, eğitime teknoloji entegrasyonu arttıkça bu etkinin düşeceği ön görülmektedir.

Yaş Gruplarına Göre Öğretmenlerin Teknolojik Pedagojik Alan Bilgileri

Öğretmenlerin TB, PB, AB, TPB, TAB, PAB ve TPAB düzeylerini belirli yaş gruplarına göre kıyaslamak için tek faktörlü MANOVA analizi yapılmıştır. Öğretmenlerin yaş gruplarına göre TPAB boyutlarına yönelik puanları bütüncül olarak anlamlı bir farklılık göstermektedir (Pillai's Trace = 0.91, $F_{[14-468]} = 1.87$, $\eta^2 = 0.05$, $p < 0.05$). Her bir değişken için tek yönlü ANOVA sonuçlarına bakıldığında, öğretmenlerin teknolojik bilgi ($F_{[2-239]} = 9.14$, $\eta^2 = 0.07$, $p < 0.01$), teknolojik alan bilgisi ($F_{[2-239]} = 3.70$, $\eta^2 = 0.03$, $p < 0.05$) ve pedagojik alan bilgisi düzeylerinde ($F_{[2-239]} = 3.93$, $\eta^2 = 0.03$, $p < 0.05$) yaş gruplarına göre anlamlı farklılık bulunmuştur. 20-29 yaş aralığındaki öğretmenlerin teknolojik bilgi ($\bar{X} = 59.33$, $Ss = 12.31$), teknolojik alan bilgisi ($\bar{X} = 15.38$, $Ss = 2.69$) ve pedagojik alan bilgisi düzeyleri ($\bar{X} = 28.04$, $Ss = 4.04$); 30-39 yaş aralığındaki öğretmenlerin teknolojik bilgi ($\bar{X} = 53.90$, $Ss = 12.21$), teknolojik alan bilgisi ($\bar{X} = 14.53$, $Ss = 2.78$) ve pedagojik alan bilgisi düzeylerinden ($\bar{X} = 26.83$, $Ss = 4.16$) ve 40 yaş üzeri öğretmenlerin teknolojik bilgi ($\bar{X} = 50.91$, $Ss = 12.66$), teknolojik alan bilgisi ($\bar{X} = 14.23$, $Ss = 2.97$) ve pedagojik alan bilgisi düzeylerinden ($\bar{X} = 26.21$, $Ss = 4.18$) yüksektir. Yaşın

teknolojik bilgi düzeyi üzerinde etkisi orta düzeyde olup toplam varyansın %7'sini açıklamasına rağmen teknolojik alan bilgisi ve pedagojik alan bilgisi düzeyleri üzerinde etkisi düşük olup toplam varyansın %3'ünü açıklamaktadır. Yapılan çalışmalarda genel olarak yaşın TB düzeyiyle negatif yönde (Chuang & Ho, 2011; Kazu & Erten, 2014; Koh & Sing, 2011; Koh vd., 2014), PAB düzeyiyle ise pozitif yönde ilişkili olduğu (Chuang & Ho, 2011; Koh vd., 2014; Kazu & Erten, 2014) belirtilmiştir. Yaş ilerledikçe yeni teknolojileri öğrenmenin zorluğu teknolojik bilgiyi olumsuz etkilemektedir. Bununla birlikte pedagojik alan bilgisinin artmasında yaşla birlikte tecrübenin de ortak etkisi olduğu görülmektedir (Koh vd., 2014).

Eğitim Durumlarına Göre Öğretmenlerin Teknolojik Pedagojik Alan Bilgileri

Öğretmenlerin TB, PB, AB, TPB, TAB, PAB ve TPAB düzeylerini eğitim durumlarına göre kıyaslamak için tek faktörlü MANOVA analizi yapılmıştır. Öğretmenlerin eğitim durumlarına göre TPAB boyutlarına yönelik puanları bütüncül olarak anlamlı farklılık göstermiştir (Wilk's Lambda = 0.94, $F_{[7-234]} = 2.12$, $\eta^2 = 0.06$, $p < 0.05$). Her bir değişken için tek yönlü ANOVA sonuçlarına bakıldığında, öğretmenlerin alan bilgisi ($F_{[1-240]} = 6.01$, $\eta^2 = 0.02$, $p < 0.05$) ve teknolojik pedagojik alan bilgisi düzeylerinde ($F_{[1-240]} = 5.02$, $\eta^2 = 0.02$, $p < 0.05$) eğitim durumlarına göre anlamlı farklılık bulunmuştur. Eğitim durumu lisansüstü olan öğretmenlerin alan bilgisi ($\bar{X} = 25.11$, $Ss = 3.29$) ve teknolojik pedagojik alan bilgisi düzeyleri ($\bar{X} = 20.11$, $Ss = 2.78$), lisans mezunu öğretmenlerin alan bilgisi ($\bar{X} = 23.25$, $Ss = 3.87$) ve teknolojik pedagojik alan bilgisi düzeylerinden ($\bar{X} = 18.90$, $Ss = 3.37$) yüksektir. Ancak eğitim durumunun alan bilgisi ve teknolojik pedagojik alan bilgisi düzeyleri üzerindeki etkisi düşük olup, alan bilgisi düzeyinde toplam varyansın %3'ünü ve teknolojik pedagojik alan bilgisi düzeyi üzerinde ise toplam varyansın sadece %2'sini açıklamaktadır. Lisansüstü eğitimde öğretmenler alanında uzmanlaştıkları için, lisans mezunu öğretmenlere göre alan bilgisi düzeyleri buna bağlı olarak da TPAB düzeyleri yüksek olabileceği söylenebilir.

Eğitimde Bilişim Teknolojileri Kullanımına Göre Öğretmenlerin Teknolojik Pedagojik Alan Bilgileri

Öğretmenlerin TB, PB, AB, TPB, TAB, PAB ve TPAB düzeylerini eğitimde bilişim teknolojilerini kullanım düzeylerine göre kıyaslamak için tek faktörlü MANOVA analizi yapılmıştır. Öğretmenlerin eğitimde bilişim teknolojileri kullanımına göre TPAB boyutlarına yönelik puanları bütüncül olarak anlamlı farklılık göstermiştir (Pillai's Trace = 0.35, $F_{[28-936]} = 3.21$, $\eta^2 = 0.09$, $p < 0.01$). Her bir değişken için tek yönlü ANOVA sonuçlarına bakıldığında, öğretmenlerin teknolojik bilgi ($F_{[4-237]} = 16.28$, $\eta^2 = 0.22$, $p < 0.01$), pedagojik bilgi ($F_{[4-237]} = 2.95$, $\eta^2 = 0.05$, $p < 0.05$), alan bilgisi ($F_{[4-237]} = 4.34$, $\eta^2 = 0.07$, $p < 0.01$), teknolojik pedagojik bilgi ($F_{[4-237]} = 5.54$, $\eta^2 = 0.09$, $p < 0.01$), teknolojik alan bilgisi ($F_{[4-237]} = 8.36$, $\eta^2 = 0.12$, $p < 0.01$), pedagojik alan bilgisi ($F_{[4-237]} = 3.53$, $\eta^2 = 0.06$, $p < 0.01$) ve teknolojik pedagojik alan bilgisi düzeylerinde ($F_{[4-237]} = 6.14$, $\eta^2 = 0.09$, $p < 0.01$), eğitimde bilişim teknolojilerini kullanım düzeylerine göre anlamlı farklılık bulunmuştur. Eğitimde bilişim teknolojilerini her zaman kullanan öğretmenlerin; TB ($\bar{X} = 64.89$, $Ss = 10.28$), AB ($\bar{X} = 25.16$, $Ss = 3.53$), TPB ($\bar{X} = 16.60$, $Ss = 2.59$), TAB ($\bar{X} = 16.35$, $Ss = 2.77$) ve TPAB düzeyleri ($\bar{X} = 20.50$, $Ss = 2.83$) eğitimde bilişim teknolojilerini hiç kullanmayan öğretmenlerin; TB ($\bar{X} = 51.39$, $Ss = 14.09$), AB ($\bar{X} = 22.28$, $Ss = 4.10$), TPB ($\bar{X} = 14.00$, $Ss = 2.72$), TAB ($\bar{X} = 13.50$, $Ss = 3.22$) ve TPAB düzeylerinden ($\bar{X} = 17.28$, $Ss = 3.10$) yüksektir. Eğitimde bilişim teknolojileri kullanım düzeylerinin; teknolojik bilgi düzeyi üzerinde etkisi geniş olup toplam varyansın %22'sini açıklamaktadır. Eğitimde bilişim teknolojilerini kullanım düzeylerinin AB, TPB, TAB, PAB ve TPAB düzeyleri üzerinde etkisinin orta düzeyde, pedagojik bilgi düzeyi üzerinde ise düşük düzeyde bir etkiye sahip olduğu görülmektedir. Akyüz ve arkadaşları (2014) deneysel çalışmalarında akıllı tahta kullanımının fen bilgisi öğretmen adaylarının TPAB düzeylerine olumlu etkisi olduğunu belirtmişlerdir. Demir ve Bozkurt (2011) ise öğretmenlerin teknoloji entegrasyonunda sahip olması gereken yeterliklerin teknoloji bilgisi ile ilişkilendirildiğini ve etkili bir teknoloji kullanımı açısından değerli görüldüğünü belirtmiştir. Buna göre eğitimde bilişim teknolojileri kullanımı ile TPAB düzeylerinin birbirini pozitif yönde etkilediği söylenebilir.

İnternet Kullanım Sıklıklarına Göre Öğretmenlerin Teknolojik Pedagojik Alan Bilgileri

Öğretmenlerin TB, PB, AB, TPB, TAB, PAB ve TPAB düzeylerini internet kullanım sıklığı düzeylerine göre kıyaslamak için tek faktörlü MANOVA analizi yapılmıştır. Öğretmenlerin internet kullanım sıklıklarına göre TPAB boyutlarına yönelik puanları bütüncül olarak anlamlı farklılık göstermiştir (Wilk's Lambda = 0.68, $F_{[28-834.31]} = 0.68$, $\eta^2 = 0.09$, $p < 0.01$). Her bir değişken için tek yönlü ANOVA sonuçlarına bakıldığında, öğretmenlerin teknolojik bilgi ($F_{[4-237]} = 22.59$, $\eta^2 = 0.28$, $p < 0.01$), pedagojik bilgi ($F_{[4-237]} = 3.56$, $\eta^2 = 0.06$, $p < 0.01$), alan bilgisi ($F_{[4-237]} = 2.92$, $\eta^2 = 0.05$, $p < 0.05$), teknolojik pedagojik bilgi ($F_{[4-237]} = 7.45$, $\eta^2 = 0.11$, $p < 0.01$), teknolojik alan bilgisi ($F_{[4-237]} = 7.86$, $\eta^2 = 0.12$, $p < 0.01$), pedagojik alan bilgisi ($F_{[4-237]} = 4.60$, $\eta^2 = 0.07$, $p < 0.01$) ve teknolojik pedagojik alan bilgisi düzeylerinde ($F_{[4-237]} = 4.86$, $\eta^2 = 0.08$, $p < 0.01$), internet kullanım sıklıklarına göre anlamlı farklılık bulunmuştur. İnterneti günde 4 saat ve üzeri kullanan öğretmenlerin; TB ($\bar{X} = 65.33$, $Ss = 10.86$), PB ($\bar{X} = 23.76$, $Ss = 3.64$), AB ($\bar{X} = 24.84$, $Ss = 3.84$), TPB ($\bar{X} = 16.55$, $Ss = 2.70$), TAB ($\bar{X} = 16.25$, $Ss = 2.74$), PAB ($\bar{X} = 28.69$, $Ss = 4.26$) ve TPAB düzeyleri ($\bar{X} = 20.44$, $Ss = 3.64$); interneti haftada

1-2 saat kullanan öğretmenlerin; TB ($\bar{X} = 45.14$, $Ss = 7.88$), PB ($\bar{X} = 20.96$, $Ss = 3.72$), AB ($\bar{X} = 22.07$, $Ss = 3.10$), TPB ($\bar{X} = 13.54$, $Ss = 1.95$), TAB ($\bar{X} = 13.04$, $Ss = 2.47$), PAB ($\bar{X} = 24.93$, $Ss = 4.00$) ve TPAB düzeylerinden ($\bar{X} = 17.50$, $Ss = 3.04$) yüksektir. İnternet kullanım sıklığının; teknolojik bilgi düzeyi üzerinde etkisi geniş olup toplam varyansın %28'ini açıklamaktadır. İnternet kullanım sıklığının PB, TPB, TAB, PAB ve TPAB düzeyleri üzerinde etkisinin orta düzeyde, AB düzeyi üzerinde ise düşük düzeyde bir etkiye sahip olduğu görülmektedir. Chuang ve Ho (2011) çalışmalarında teknoloji kullanım sıklığı ile TB, PB, AB, TPB ve TAB düzeyleri arasında anlamlı ilişkili olduğunu belirtmişlerdir. Sonuç olarak internete erişimin bilgiye erişimle eşdeğer olarak görüldüğü günümüzde, internet kullanım sıklığının bilginin tüm alanlarını etkilediği söylenebilir.

SONUÇ ve ÖNERİLER

Bu çalışmada öğretmenlerin TPAB düzeylerini etkileyen çeşitli faktörler olduğu görülmüştür. Mishra ve Koehler'in (2005) oluşturmuş olduğu TPAB ile ilgili araştırmalar genellikle öğretmen adayları üzerine yoğunlaşmış olup, son yıllarda öğretmenlere yönelik yapılan çalışmaların arttığı görülmektedir. Bu çalışmada öğretmenlerin cinsiyet, yaş, eğitim durumu, eğitimde BT kullanımı ve internet kullanım sıklığına göre TPAB düzeyleri incelenmiş olup, sonuçları şu şekildedir:

- Öğretmenlerin teknoloji ve pedagojik alan bilgisi cinsiyete göre anlamlı farklılık göstermektedir. Erkeklerin teknolojik bilgisi düzeyinin kadınlardan, kadınların pedagojik alan bilgi düzeyinin ise erkeklerden yüksek olduğu görülmektedir.
- Öğretmenlerin teknolojik bilgi, teknolojik alan bilgisi ve pedagojik alan bilgisi düzeylerinde yaş gruplarına göre anlamlı farklılık bulunmuştur. 20-29 yaş grubu öğretmenlerin TB, TAB, PAB düzeylerinin diğer yaş grubundaki öğretmenlerin TB, TAB, PAB düzeylerinden yüksek olduğu görülmektedir.
- Öğretmenlerin alan bilgisi ve teknolojik pedagojik alan bilgisi düzeyleri eğitim durumlarına göre anlamlı farklılık göstermektedir. Eğitim durumu lisansüstü olan öğretmenlerin, lisans mezunu öğretmenlere göre AB ve TPAB düzeylerinin yüksek olduğu tespit edilmiştir.
- Derste bilişim teknolojilerini kullanma düzeyi daha yüksek olan öğretmenlerin, TB, PB, AB, TAB, TPB, PAB ve TPAB düzeylerinin diğer öğretmenlerin bilgi düzeylerine göre yüksek olduğu bulunmuştur.
- Öğretmenlerin internet kullanım sıklıklarına göre TPAB düzeyleri incelendiğinde ise interneti sık kullanan öğretmenlerin, interneti az kullanan öğretmenlere göre TB, PB, AB, TAB, TPB, PAB ve TPAB düzeylerinin yüksek olduğu görülmüştür.

Bu bağlamda öğretmenlerin TPAB düzeylerinin cinsiyet, yaş ve eğitim durumlarına göre anlamlı farklılıklar gösterdiğini aynı zamanda derste bilişim teknolojilerini kullanım düzeyi ve internet kullanım sıklığı ile yakından ilgili olduğu söylenebilir. Bu bulgular ışığında öğretmenlerin TPAB düzeylerinin geliştirilmesi için önerilerimiz şunlardır:

- Öğretmenlerin TPAB düzeylerinin farkında olması, kendini geliştirmesi ve eğitime teknolojiyi daha iyi entegre edebilmesi açısından faydalı olacaktır.
- Yaşça büyük olan öğretmenlerin eğitime teknoloji entegrasyonunda geride kalmamaları için, genç öğretmenlerin teknoloji ve teknolojinin eğitimde nasıl kullanılacağı ile ilgili bilgilerini yaşça büyük olan öğretmenlerle paylaşıp, aynı zamanda onların tecrübelerinden de faydalanması gerekmektedir.
- Öğretmenlerin derse teknolojiyi entegre etme konusundaki öz güvenleri artırılmalı çünkü derste teknolojiyi kullandıkça TPAB düzeylerinde de artış görülmesi muhtemeldir.
- İnternete erişimin bilgiye hızlı erişimle eşdeğer olduğu düşünüldüğünde öğretmenlerin özellikle eğitime yönelik interneti daha sık kullanmaları sağlanarak eğitimde kullanılacak web tabanlı uygulamaların yaygınlaştırılması ve öğretmenlere tanıtılması sağlanmalıdır.

Sonuç olarak yapılan bu ve buna benzer çalışmalarla, eğitime teknoloji entegrasyonunun tek bir boyutu olmadığını, çok boyutlu düşünülmesinin gerekliliğinin farkına varılacak ve öğretmenlerin TPAB düzeylerinin, eğitime teknoloji entegrasyonunda önemi daha net anlaşılacaktır.

KAYNAKLAR

- Akyüz, H. İ., Pektaş, M., Kurnaz, M. A., & Memiş, E. K. (2014). Akıllı tahta kullanımlı mikro öğretim uygulamalarının fen bilgisi öğretmen adaylarının TPAB'larına ve akıllı tahta kullanıma yönelik algılarına etkisi. *Cumhuriyet International Journal of Education-CIJE*, 3(1), 1-14
- Carr, A. A., Jonassen, D. H., Litzinger, M. E., & Marra, R. M. (1998). Good ideas to foment educational revolution: The role of systematic change in advancing situated learning, constructivism, and feminist pedagogy. *Educational Technology*, 38(1), 5-14.
- Chuang, H.-H. & Ho, C.-J. (2011). An investigation of early childhood teachers' technological pedagogical content knowledge (TPACK) in Taiwan. *Ahi Evran Üniversitesi Eğitim Fakültesi Dergisi*, 12(2), 99-117.

- Demir, S. & Bozkurt, A. (2011). İlköğretim matematik öğretmenlerinin teknoloji entegrasyonundaki öğretmen yeterliklerine ilişkin görüşleri. *İlköğretim Online*, 10(3), 850-860.
- Demirer, V., Saban, A., Küçük, Ş., & Şahin, İ. (2011). Bilişim teknolojileri öğretmen adaylarının fatih projesi hakkındaki görüşlerinin değerlendirilmesi. *11th International Educational Technology (IETC2011)*, İstanbul.
- Erdogan, A., & Sahin, I. (2010). Relationship between math teacher candidates' Technological Pedagogical And Content Knowledge (TPACK) and achievement levels. *Procedia-Social and Behavioral Sciences*, 2(2), 2707-2711.
- Ferdig, R. E. (2006). Assessing technologies for teaching and learning: understanding the importance of technological pedagogical content knowledge. *British Journal of Educational Technology*, 37(5), 749-760.
- Jang, S.-J. & Tsai, M.-F. (2012). Exploring the TPACK of Taiwanese elementary mathematics and science teachers with respect to use of interactive whiteboards. *Computers & Education*, 59, 327-338.
- Jang, S.-J. & Tsai, M.-F. (2013). Exploring the TPACK of Taiwanese secondary school science teachers using a new contextualized TPACK model. *Australasian Journal of Educational Technology* 29(4), 566-580.
- Kayaduman, H., Sırakaya, M., & Seferoğlu, S. S. (2011). Eğitimde FATİH projesinin öğretmenlerin yeterlik durumları açısından incelenmesi. Akademik Bilişim'11 - XIII. Akademik Bilişim Konferansı Bildirileri, 2 - 4 Şubat 2011 İnönü Üniversitesi, Malatya. 123-129.
- Kazu, İ. Y. & Erten, P. (2014). Teachers' technological pedagogical content knowledge self-efficacies. *Journal of Education and Training Studies* 2(2), 126-144.
- Kereluik, K., Mishra, P., & Koehler, M. J. (2011). On learning to subvert signs: Literacy, technology and the TPACK framework. *The California Reader*, 44(2) 12-18.
- Koehler, M. J. & Mishra, P. (2005). What happens when teachers design educational technology? The development of technological pedagogical content knowledge. *J. Educational Computing Research*, 32(2) 131-152.
- Koehler, M. J., & Mishra, P. (2009). What is technological pedagogical content knowledge? *Contemporary Issues in Technology and Teacher Education*, 9(1), 60-70.
- Koh, J. H. L. & Chai, C. S. (2011). Modeling pre-service teachers' technological pedagogical content knowledge (TPACK) perceptions: The influence of demographic factors and TPACK constructs. In G. Williams, P. Statham, N. Brown, B. Cleland (Eds.), *Changing Demands, Changing Directions. Proceedings ascilite Hobart 2011* (pp.735-746).
- Koh, J. H. L., & Sing, C. C. (2011). Modeling pre-service teachers' technological pedagogical content knowledge (TPACK) perceptions: The influence of demographic factors and TPACK constructs. Paper presented at the *Ascilite 2011 Conference*, Hobart, Tasmania.
- Koh, J. H. L., Chai, C. S., & Tsai, C. C. (2014). Demographic factors, TPACK constructs, and teachers' perceptions of constructivist-oriented TPACK. *Educational Technology & Society*, 17(1), 185-196.
- Lin, T.-C., Tsai, C.-C., Chai, C. S., & Lee, M.-H. (2013). Identifying science teachers' perceptions of technological pedagogical and content knowledge (TPACK). *J Sci Educ Technol*, 22, 325-336.
- Özgen, K., Narlı, S., Alkan, H. (2013). Matematik öğretmen adaylarının teknolojik pedagojik alan bilgileri ve teknoloji kullanım sıklığı algılarının incelenmesi. *Elektronik Sosyal Bilimler Dergisi*, 12(44), 31-51.
- Pamuk, S., Ülken, A., & Dilek, N. Ş. (2012). Öğretmen adaylarının öğretimde teknoloji kullanım yeterliliklerinin teknolojik pedagojik içerik bilgisi kuramsal perspektifinden incelenmesi. *Mustafa Kemal Üniversitesi Sosyal Bilimler Enstitüsü Dergisi*, 9(17), 415-438.
- Sahin, I. (2011). Development of survey of technological pedagogical and content knowledge (TPACK). *Turkish Online Journal of Educational Technology*, 10(1), 97-105.
- Shulman, L. S. (1987). Knowledge and teaching: Foundations of the new reform. *Harvard Educational Review*, 57(1), 1-22.
- Wang, T. (2009). Rethinking teaching with information and communication technologies (ICTs) in architectural education. *Teaching and Teacher Education*, 25, 1132-1140.

AZERBAIJAN VE TÜRKİYE’DE OKUTULAN 1.SINIF MATEMATİK DERS KİTAPLARININ İÇERİK AÇISINDAN KARŞILAŞTIRILMASI

THE COMPARISON OF TURKISH AND AZERBAIJAN MATHEMATICS TEXTBOOK BASED ON THEIR CONTENT

Nimet PIRASA
Recep Tayyip Erdoğan Üniversitesi
nimet.pirasa@erdogan.edu.tr

ÖZET: Ders kitapları hem öğretmenlerin ders işleyişinde, hem de öğrencilerin ders çalışırken başvurdukları birincil eğitsel kaynaklardır. Yapılan çalışmalarda, 2005 İlköğretim 1-5. Sınıflar Matematik Dersi Öğretim Programı doğrultusunda hazırlanan ve MEB tarafından basılan ders kitaplarının öğretmenlerin öğretim programını anlama ve yorumlamada onlara yol gösterici olduğu anlaşılmaktadır. Bu çalışmada Azerbaycan ve Türkiye’de okutulan 1.sınıf matematik ders kitaplarının içerik açısından karşılaştırılması amaçlanmıştır. Bunun için Azerbaycan’da okutulan Radius Yayıncılık tarafından 2012 yılında basılmış 1.sınıf ders kitabı, Türkiye’de okutulan matematik ders kitaplarından biri olan MEB tarafından 2013 yılında basılmış İlköğretim 1. Sınıf Matematik Ders Kitabı ele alınmıştır. Bu kitapların içerik analizi yapılmıştır. Bu kitaplar içerik düzeni, öğrenme alanlarına verilen ağırlık, konu başlıkları, konuların sunulduğunda hâkim olunan yaklaşımlar vb. açılardan karşılaştırılmıştır. Bu doğrultuda matematik ders kitaplarının içerik açısından düzenlenmesi konusunda önerilerde bulunulmuştur.

Anahtar sözcükler: matematik ders kitabı, ilköğretim 1.sınıf matematik eğitimi, uluslararası karşılaştırmalı çalışma

ABSTRACT: Textbooks are primary educational resources for teachers while teaching and for students while studying. It is stated that the textbooks are prepared in accordance with Elementary Mathematics Education Program for 1-5. Grades (2005) and published by Turkish Ministry of National Education (MNE) were the guidance of the teachers to understand and interpret the curriculum. In this study, it is aimed to compare Azerbaijan and Turkey mathematics textbooks at grade level 1. Thus, the mathematics textbooks for grade level 1 published by Radius Publishing in 2012 in Azerbaijan and MNE Publishing in 2013 in Turkey are analyzed. The comparisons focused on their organization of chapters, the relative weights of learning domain, content topics covered, styles of presentation, etc. In this respect, it is made suggestions regarding the regulation of the content of mathematics textbooks.

Key words: mathematics textbooks, elementary mathematics education at grade 1st, international comparative studies

EĞİTSEL OYUNLARLA MATEMATİK ÖĞRETİMİ DERSİNDE TASARLANAN OYUNLARIN ANALİZİ

THE ANALYSES OF GAMES AT MATHEMATICS TEACHING WITH EDUCATIONAL GAMES COURSE

Nimet PIRASA
Recep Tayyip Erdoğan Üniversitesi
nimet.pirasa@erdogan.edu.tr

ÖZET: Matematik dersinin zor ve anlaşılması kolay olmayan derslerin başında geldiği ve bu yüzden pek sevilmediği bir gerçektir. Matematiğe karşı olumlu tutum geliştirilmelidir (MEB,2005). Çocuk için oyun eğlenceli bir uğraş olmasının yanı sıra birçok şeyi farkına varmadan öğrendiği bir süreçtir. Çoğu derste eğitsel oyunlarla dersin öğretilmesi tavsiye edilmektedir. Çünkü çocuk oyun içerisinde deneyim kazanmakta, taktikler geliştirmekte, düşünüp çözüm yolları üretmekte ve çeşitli kararlar almaktadır (MEB, 2006). Bu çalışmada seçmeli ders olarak okutulan Eğitsel Oyunlarla Matematik Öğretimi dersinde 52 öğrencinin oluşturmuş olduğu eğitsel oyunların analizi yapılmıştır. Bu ders kapsamında öğrencilerin her hafta gerek bireysel gerekse de grup olarak inceledikleri veya tasarladıkları oyunlar (eğitsel bilgisayar oyunları, matematik araçlarıyla tasarlanan eğitsel oyunlar, sınıf içinde materyal kullanılmadan oynanabilen eğitsel oyunlar ve el yapımı materyallerin kullanıldığı eğitsel oyunlar gibi) ele alınan konu, oyunda kullanılan araç gereçler ve uygulanabilirlik açısından sınıflandırılmıştır. Bu doğrultuda ortaokul matematik derslerinde oynatılabilecek farklı türde eğitsel oyunlar ile ilgili fikir sahibi olunacaktır.

Anahtar sözcükler: eğitsel oyun, matematik, öğretmen adayı

ABSTRACT: It is known that math lesson is the beginning of the primarily course that is difficult and not easy to understand and therefore not much liked. Positive attitudes should be developed towards mathematics. For children game is a fun exercise besides a process that can be learnt many things without realizing. At most of the courses it is recommended to be taught with educational games. Owing to the game process child gains experience, develops tactics, produces many solutions and makes several decisions. In this study educational games that have been designed by 52 students at the course of Mathematics Teaching with Educational Games are analyzed. Educational games (computer games, with math tools games, with no material games and with handmade materials games, etc.) that are scanned or designed by students in the course period are classified in terms of the math topics, the tools used in etc. Accordingly the options of educational games that can be played in middle school math classes will have an idea about.

Key words: educational games, mathematics, pre-service teacher

SPATIAL SKILLS AS PREDICTORS OF SUCCESS IN MATHEMATICS

Sheryl SORBY

The ability to visualize in three dimensions is a cognitive skill that has been shown to be important for success in engineering and other technological fields. For engineering, the ability to mentally rotate 3-D objects is especially important. Unfortunately, of all the cognitive skills, 3-D rotation abilities exhibit robust gender differences, favoring males. The assessment of 3-D spatial skills and associated gender differences has been a topic of educational research for nearly a century; however, a great deal of the previous work has been aimed at merely identifying differences. For nearly two decades, the author has been conducting research aimed at identifying practical methods for improving 3-D spatial skills, especially for women engineering students. This presentation details the significant findings obtained over the past several years through this research and identifies strategies that appear to be effective in developing 3-D spatial skills and in contributing to student success. Data obtained for students enrolled in introductory mathematics courses will also be presented.

Keywords: spatial skills, gender differences, student success

GÖRÜNTÜ PARAMETRELERİNİN PARÇACIK SÜRÜ OPTİMİZASYONU YÖNTEMİ İLE ENİYİLEMESİ

OPTIMIZING IMAGE PARAMETERS BY PARTICAL SWARM OPTIMIZATION

Hasan DİKMEN¹, Hüseyin DİKMEN¹, Ahmet ELBİR², Özdemir ÇETİN¹
¹ Sakarya Üniversitesi, hasan.dikmen ,huseyin.dikmen ,ocetin@sakarya.edu.tr
² Yıldız Teknik Üniversitesi, aelbir@yildiz.edu.tr

ÖZET: Sayısal bilgisayarlar hayatımızın vazgeçilmez bir parçasıdır. Sayısal bilgisayarlar yardımıyla günlük hayatımızda kullanılan veriler hızlı ve etkin bir şekilde işlenip bilgi çıkarımı yapılmaktadır. Bilgi çıkarımı sırasında kullanılan bu verilerden en önemlisi optik aygıtlar aracılığıyla elde edilen sayısal görüntülerdir. Sayısal görüntülerin işlenmesi için çeşitli yöntemler bulunmaktadır. Bu yöntemlerden en çok kullanılanı, görüntü zenginleştirme yöntemidir. Bu çalışmada, görüntülerin zenginleştirilmesi işlemi için bazı görüntü parametrelerinin parçacık sürü optimizasyonu (PSO) yöntemiyle eniyilemesi gerçekleştirilmiştir. Görüntünün kontrast (karşıtlık), parlaklık ve gama bileşenleri PSO algoritmasıyla sezgisel olarak iyileştirilmiştir. Bu işlemleri kullanıcının kolay uygulayabilmesi ve sonuçları gözlemleyebilmesi için, C# tabanlı bir grafik ara yüz gerçekleştirilmiştir. Geliştirilen yazılım, görüntü işleme ve yapay zekâ konularında eğitim yazılımı olarak kullanılabilir.

Anahtar sözcükler: görüntü iyileştirme, parçacık sürü optimizasyonu, pso

ABSTRACT: Digital computers are indispensable part of our lives. Physical signals in the real world are processed via computers quickly and efficiently. As a result of this process, information extraction is carried out. During the information extraction, digital images are used frequently. The digital image is two dimensional data that is obtained by optical devices. There are many methods for the processing of digital images. One of the most important methods of image processing is image enhancement. In this study, Image enhancement has been carried out by particle swarm optimization method. Some important image parameters such as brightness, contrast and gamma values, have been optimized with Particle Swarm Optimization. A graphical user interface has been implemented by C# to use easily and to examine visually optimization results. The developed software can be used as educational software for image processing and artificial intelligence.

Key words: image enhancement, particle swarm optimization, PSO

GİRİŞ

Sayısal görüntü işleme ve yapay zekâ günümüzde çok sayıda araştırmaların yapıldığı alanlardır. Günlük hayatta birçok kaynaktan elde edilen görüntü verilerinden bilgi çıkarımı yapmak için klasik teknikler ve yapay zekâ teknikleri geliştirilmiştir. Örneğin; görüntü onarma, görüntü bölütleme, görüntü sıkıştırma ve görüntü iyileştirme görüntü işlemede sıklıkla kullanılan tekniklerdir. Görüntü iyileştirme tekniği, mevcut görüntüden bilgi çıkarımı yapabilmek için görüntünün niteliklerinin yükseltilmesi olarak tanımlanabilir (Gonzalez ve Woods, 2007). Mevcut görüntüden daha nitelikli görüntü elde etmek için kullanılan çok fazla yöntem bulunmaktadır. Histogram dengeleme, kontrast iyileştirme bunlardan bazılarıdır. Görüntü iki boyutlu bir işaret olduğu için, görüntüler üzerinde klasik algoritmaların kullanılması çok fazla işlem karmaşıklığına neden olmaktadır. Sayısal bilgisayarın bellek kapasitesi sınırlı olduğu için yapay zekâ yöntemleri sayesinde daha az işlem karmaşıklığıyla daha kaliteli sonuçlar alabilmek klasik yöntemlere göre daha mümkündür. Bu çalışmada görüntü parametreleri, sürü zekâ yöntemlerinden olan parçacık sürü optimizasyonu ile iyileştirilmiştir. Görüntünün parlaklık, karşıtlık ve gama parametreleri, görüntünün istatistiksel değerleri kullanılarak sezgisel olarak iyileştirilmiş ve sonuç olarak daha çok bilgi verebilecek nitelikte görüntüler elde edilmiştir. Yapılan tüm işlemlerin görüntü işleme ve yapay zekâ eğitiminde eğitim yazılımı olarak etkin bir şekilde kullanılması için görsel ara yüz geliştirilmiştir. Bu sayede görüntü parametrelerinin değiştirilmesinin sonuca etkisi, kullanılan yapay zekâ yönteminin çalışma prensibi rahatlıkla gözlemlenebilmektedir.

Çalışmanın ikinci bölümünde, literatür çalışması ve görüntünün iyileştirilmesi işleminde kullanılan PSO yöntemi detaylı olarak incelenmiştir. Sürü zekâsına göre matematiksel olarak modellenen PSO algoritması, bir çok alanda karşılaşılan optimizasyon problemlerinin çözümünde başarılı sonuçlar vermektedir. Tekrarlama sayısı önceden belirlenen bu yöntemle arama uzayında elde edilen en iyi sonuç bulunmuş ve görüntünün iyileştirilmesi gerçekleştirilmiştir. Üçüncü bölümde, görüntü iyileştirme ve PSO işlemlerini etkin ve görsel olarak gerçekleştiren uygulama hakkında bilgiler verilmiştir. Tasarlanan bu yazılım, verilen bir görüntüyü iyileştirmekle birlikte, sayısal görüntü işleme ve yapay zekâ gibi ilgili konularda verilen eğitimlere kaynak olarak kullanılabilir.

LİTERATÜR ÇALIŞMASI VE PARÇACIK SÜRÜ OPTİMİZASYONU

Parçacık Sürü Optimizasyonu (PSO), ilk olarak Kennedy ve Eberhart tarafından 1995 yılında ortaya atılmış popülasyon temelli sezgisel bir optimizasyon yöntemidir (Kennedy ve Eberhart, 1995). PSO algoritması hayvanlar arasındaki sosyal etkileşimden esinlenerek bulunan ve temel olarak sürü zekâsına dayanan bir algoritmadır. Kuş ve balık sürülerinin yiyecek arayışları ve tehlikeden kaçışları esnasındaki toplu hareketlerinden esinlenerek modellenmiştir. PSO hızlı sonuç bulması, az parametre gerektirmesi ve yerel optimumlara takılma riskinin az olması sebebiyle diğer birçok arama algoritmasına üstünlük kurmuştur. PSO, yapay sinir ağı eğitimi, fonksiyon optimizasyonu, sıralama ve çizelgeleme problemleri gibi yapısında çok fazla değişken ve parametre barındıran problemlerin çözümünde başarı ile kullanılmıştır (Bergh, 1999).

PSO'da her bir elemana parçacık (particle) denir ve parçacıklardan oluşan topluluğa da sürü (swarm) denir. Sürüdeki bütün parçacıklar çözüm uzayında rastgele değerler olarak arama işlemine başlarlar. Her bir parçacık konum (X) ve hız (V) vektörü olmak üzere iki vektörel bileşene sahiptir. Konum vektörü parçacığın konum bilgisini, hız vektörü ise parçacığın konum değiştirme miktarı ve yön bilgisini tutar. PSO, temel olarak sürüdeki her bir parçacığın konumunu, daha önce bulmuş olduğu en iyi konuma (pbest) ve sürünün o ana kadar bulmuş olduğu en iyi konuma (gbest) yaklaştırmasına dayanır. Tüm parçacıklar hız vektörleriyle bu iki en iyi konuma yönelmeye çalışırlar (Ortakçı ve Göloğlu 2012).

Örneğin parçacık sürüsünün D boyutlu N adet parçacıktan oluştuğunu varsayalım. Bu durumda popülasyon parçacık matrisi eşitlik (1)'deki gibidir.

$$X = \begin{bmatrix} X_{11} & X_{12} & \dots & \dots & X_{1D} \\ X_{21} & X_{22} & \dots & \dots & X_{2D} \\ \dots & \dots & \dots & \dots & \dots \\ \dots & \dots & \dots & \dots & \dots \\ X_{N1} & X_{N2} & \dots & \dots & X_{ND} \end{bmatrix}_{N \times D} \quad (1)$$

i 'nci parçacığın konumu $X_i = [X_{i1}, X_{i2}, \dots, X_{iD}]$ olarak gösterilir.

i 'nci parçacığın hızı $V_i = [V_{i1}, V_{i2}, \dots, V_{iD}]$ olarak gösterilir.

i 'nci parçacığın önceki iterasyonlarda bulduğu en iyi konum $pbest_i = [P_{i1}, P_{i2}, \dots, P_{iD}]$ olarak gösterilir.

Parçacık sürüsü tarafından önceki iterasyonlarda bulunan en iyi konum $gbest = [P_1, P_2, \dots, P_D]$ olarak gösterilir.

Her bir iterasyonda parçacıkların hızları ve konumları aşağıda verilen (2) ve (3) nolu denklemlere göre güncellenir (Gözde vd., 2008).

$$V_i^{k+1} = W \cdot V_i^k + c_1 \cdot rand_1^k (pbest_i^k - X_i^k) + c_2 \cdot rand_2^k (gbest^k - X_i^k) \quad (2)$$

$$X_i^{k+1} = X_i^k + V_i^{k+1} \quad (3)$$

c_1, c_2 : Öğrenme faktörleri

$rand_1, rand_2$: $[0, 1]$ arasında düzgün dağılımlı rastgele sayılar

W : Eylemsizlik ağırlığı

k : İterasyon sayısı

PSO Parametreleri

Parçacık sayısı: Sürüyü oluşturan her bir elemandır. Sayısı problemin türüne göre değişebilir.

Parçacık boyutu: Optimum değeri bulunacak uygunluk fonksiyondaki değişken sayısını belirtir. Örneğin; $f(x) = 5x^2 + 3y^3 + (z/w)^2 + 4$ fonksiyonu 4 boyutlu bir fonksiyondur. (Tamer ve Karakuzu, 2006).

Parçacık aralığı: Problem tabanlı olarak değişmektedir. Uygunluk fonksiyonundaki değişkenlerin aralıkları ile tespit edilir. (Tamer ve Karakuzu, 2006).

V_{max} : Parçacığın ulaşabileceği maksimum hızı belirler ve bu değer genellikle parçacık aralığına göre belirlenir. Örneğin; parçacık $[0, 10]$ aralığında ise V_{max} değeri 10 olarak belirlenebilir. (Tamer ve Karakuzu, 2006).

Öğrenme faktörleri (c_1, c_2): c_1 ve c_2 parametreleri, her bir parçacığı pbest ve gbest konumlarına doğru yönlendiren sabit değerlerdir. c_1 parametresi, parçacığın kendi tecrübelerine göre, c_2 parametresi ise sürüdeki diğer parçacıkların tecrübelerine göre hareket etmesini sağlar. Genellikle $c_1 = c_2 = 2$ olarak seçilir.

Eylemsizlik ağırlığı (W): Global ve yerel arama arasındaki dengeyi sağlamak için kullanılır. Bu değer büyük seçilmesi parçacıkların global arama yapmasını, küçük seçilmesi ise parçacıkların yerel arama yapmasını sağlar. Genellikle $[0.1, 1]$ arasında seçilir. (Tamer ve Karakuzu, 2006).

Durma koşulu: Önceden belirlenen maksimum tekrar sayısı kadar veya sonucun belirli bir başarı yüzdesine ulaşmasına kadar belirlenir. (Tamer ve Karakuzu, 2006).

```
PSO parametrelerini belirle
Parçacık sürüsünü oluştur
Tüm parçacıkların pbest değerlerinin en iyisini gbest olarak belirle
WHILE Durma koşulu BEGIN
    Parçacıkları hareket ettir
    Eylemsizlik ağırlığını güncelle
    Parçacıkları değerlendir
```

Şekil 1. PSO Algoritması Sözde Kodu

PSO ALGORİTMASIYLA GÖRÜNTÜ İYİLEŞTİRME

Bu bölümde görüntü iyileştirme işleminin PSO algoritmasıyla nasıl gerçekleştirildiği anlatılmıştır. Geliştirilen uygulama görüntüye kontrast, parlaklık ve gama işlemleri uygulayarak görüntünün iyileştirilmesini sağlar. Bu kontrast, parlaklık ve gama işlemlerinin resme hangi değerlerde uygulanacağı ise PSO algoritması kullanılarak belirlenmiştir. PSO algoritmasının sözde kodu Şekil 1’de gösterilmektedir. PSO algoritması Tablo 1’de belirtilen parametre değerleri ile oluşturularak arama işlemi başlatılır.

Tablo 1. PSO Algoritmasının Parametre Başlangıç Değerleri

Parametre	Başlangıç Değeri
Parçacık sayısı	25
Parçacık boyutu	3 (alfa, beta, gama)
Parçacık aralığı	alfa: [0, 10], beta: [-50, 50], gama: [0, 10]
V_{max}	alfa: 10, beta: 100, gama: 10
c_1, c_2	$c_1 = 2, c_2 = 2$
W	1 (Her iterasyonda $W^{k+1} = W^k * 0.999$)
Durma koşulu	Sürünün gbest değeri art arda 1000 iterasyon güncellenmeyene kadar arama yap

PSO algoritması arama boyunca parçacıkları sürekli olarak hareket ettirir. Her yer değiştirme işleminden sonra parçacıkların yeni konumları bir uygunluk fonksiyonu tarafından değerlendirilir. Bu uygunluk fonksiyonu kendisine verilen 3 adet parametreyi (alfa, beta, gama) resmin histogramına uygulayarak yeni bir histogram elde eder. Daha sonra fonksiyon elde edilen bu yeni histogramı değerlendirerek bir uygunluk değeri döndürür. PSO algoritması da uygunluk fonksiyonunun belirlediği uygunluk değerine göre parçacıkların yeni hızlarını ve konumlarını belirler. Bu işlem iteratif olarak devam eder ve sonunda parçacıklar en iyi değere ulaşırlar.

PSO algoritması arama işlemi bitirdikten sonra sürünün arama boyunca bulmuş olduğu en iyi değer olan gbest değeri alınır. Bu değer görüntüye uygulanacak olan alfa (kontrast), beta (parlaklık) ve gama (gama) değerlerini içerir. Hesaplanan alfa, beta ve gama değerleri orijinal görüntüye uygulanarak yeni ve iyileştirilmiş görüntü elde edilir. Daha sonra yeni görüntünün ortalama (mean), ortanca (median) ve standart sapma değerleri hesaplanır. Ayrıca orijinal görüntü ile yeni görüntü karşılaştırılarak MSE (Mean Square Error), PSNR (Peak Signal to Noise Ratio) ve SSIM (Structural Similarity) değerleri hesaplanır. Son olarak iyileştirilen görüntü ve hesaplanan bu değerler ve bulunan alfa, beta, gama değerleri ekranda gösterilerek arama işlemi bitirilir.

BULGULAR

Çalışmanın bu bölümünde görüntü iyileştirme işleminin görsel olarak uygulanabilmesi ve sonuçların daha iyi bir şekilde görülebilmesi için hazırlanan C# tabanlı arayüz uygulaması anlatılmıştır. Uygulamanın ekran görüntüsü Şekil 2’de gösterilmektedir. Uygulama ekranında “Resim Yükle” butonuna basıldığında ekrana gelen diyalog penceresi kullanılarak görüntüsü iyileştirilecek resim dosyası programa yüklenir. Seçilen resim uygulama ekranının sol tarafındaki resim alanında gösterilir. Programa yüklenen resmin ortalama, ortanca ve standart sapma değerleri hesaplanarak resmin altındaki ilgili alanlarda gösterilir.

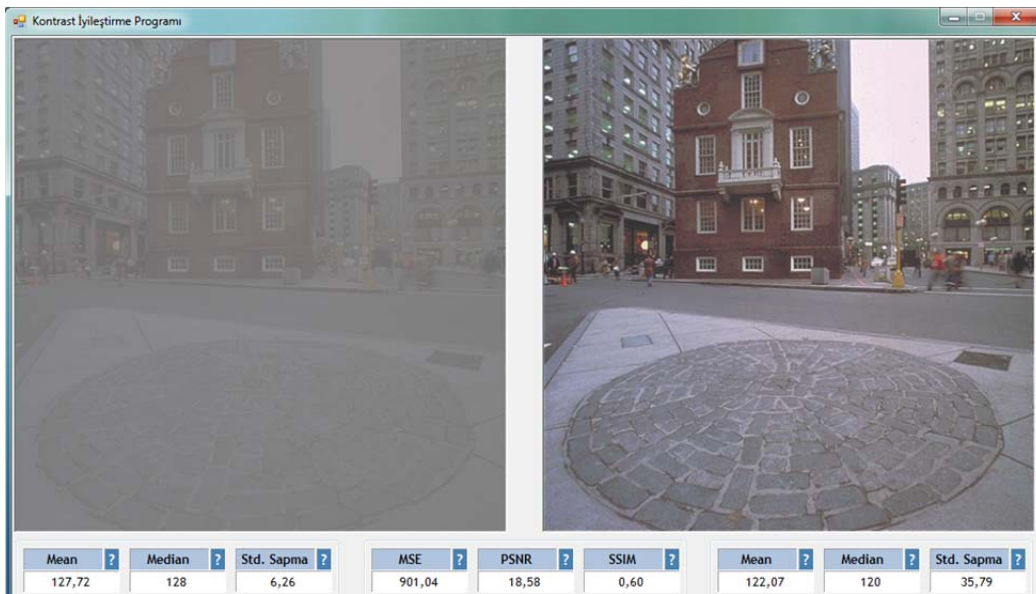

Şekil 2. Uygulamanın Ekran Görüntüsü

Resim dosyası programa yüklendikten sonra kullanıcı iki farklı yolla görüntüyü iyileştirebilir. İlk seçenekte kullanıcı uygulamadaki “Kontrast İyileştir” butonu yardımıyla PSO algoritmasını kullanarak görüntüyü iyileştirmeye çalışır. PSO algoritmasının arama sonunda bulduğu en iyi alfa, beta ve gama değerleri orijinal resmin histogramına uygulanarak yeni görüntü elde edilir. Diğer seçenekte ise kullanıcı uygulama ekranının alt orta kısmındaki “Alfa”, “Beta” ve “Gama” alanlarına istediği alfa, beta ve gama değerlerini girer ve “Parametreleri Uygula” butonu yardımıyla belirlenen alfa, beta ve gama değerleri orijinal resmin histogramına uygulanarak yeni görüntü elde edilir.

Her iki durumda da elde edilen yeni resim uygulama ekranının sağ tarafındaki resim alanında gösterilir. Daha sonra yeni resmin ortalama, ortanca ve standart sapma değerleri yeni resmin altındaki ilgili alanlarda hesaplanarak gösterilir. Son olarak orijinal görüntü ile yeni görüntü piksel boyutunda karşılaştırılarak bu iki resmin MSE (Mean Square Error), PSNR (Peak Signal to Noise Ratio) ve SSIM (Structural Similarity) değerleri hesaplanarak iki resmin alt orta kısmındaki MSE, PSNR ve SSIM alanlarında gösterilir. MSE, PSNR ve SSIM değerlerinin hesaplama formülleri (4), (5) ve (6) nolu denklemlerde gösterilmektedir.

$$MSE = \frac{1}{N \times M} \sum_{i=0}^{N-1} \sum_{j=0}^{M-1} [X(i, j) - Y(i, j)]^2 \quad (4)$$

N, M : Orijinal resmin satır ve sütun sayıları

$X(i, j)$: Orijinal resmin i. satır ve j. sütundaki piksel renk tonu

$Y(i, j)$: Yeni resmin i. satır ve j. sütundaki piksel renk tonu

$$PSNR = 20 \times \log_{10} \left(\frac{255}{\sqrt{MSE}} \right) \quad (5)$$

$$SSIM(x, y) = \frac{(2\mu_x\mu_y + C_1)(2\sigma_{xy} + C_2)}{(\mu_x^2 + \mu_y^2 + C_1)(\sigma_x^2 + \sigma_y^2 + C_2)} \quad (6)$$

μ_x : x'in aritmetik ortalaması

μ_y : y'nin aritmetik ortalaması

σ_{xy} : x ve y'nin kovaryansı

σ_x^2 : x'in varyansı

σ_y^2 : y'nin varyansı

C_1 : $(0,01 * 255)^2 = 6,5025$

C_2 : $(0,03 * 255)^2 = 58,5225$

SSIM yöntemi; NxN'lik bir çerçeve orijinal ve yeni resim üzerinde sol üstten başlayarak sağ alt köşeye kadar maskeleye yöntemi gibi gezdirilerek uygulanır. Her adımda denklem (6)'daki işlem mevcut çerçeve için yapılır. Her bir adımda elde edilen sonuçlar toplanır ve toplam sonuç adım sayısına bölünerek iki resim arasındaki SSIM değeri hesaplanır.

Kullanıcı uygulama ekranında “Resmi Kaydet” butonuna basarak iyileştirilmiş yeni resmi bmp dosya olarak bilgisayara kaydedebilir.

DENEYSEL SONUÇLAR

Bu çalışmada, çevrimiçi olarak ulaşılabilen TID2008 (TID2008, 2014) ve The CSIQ (The CSIQ, 2014) veri tabanlarından seçilen resimlere kontrast iyileştirme ve kontrast germe işlemleri ayrı ayrı uygulanmıştır. Kontrast iyileştirme işlemi geliştirilen uygulama tarafından PSO algoritması kullanılarak sezgisel olarak yapılmıştır. Her iki algoritmada elde edilen sonuçların PSNR değerleri Şekil 3'te karşılaştırılmalı olarak gösterilmektedir.

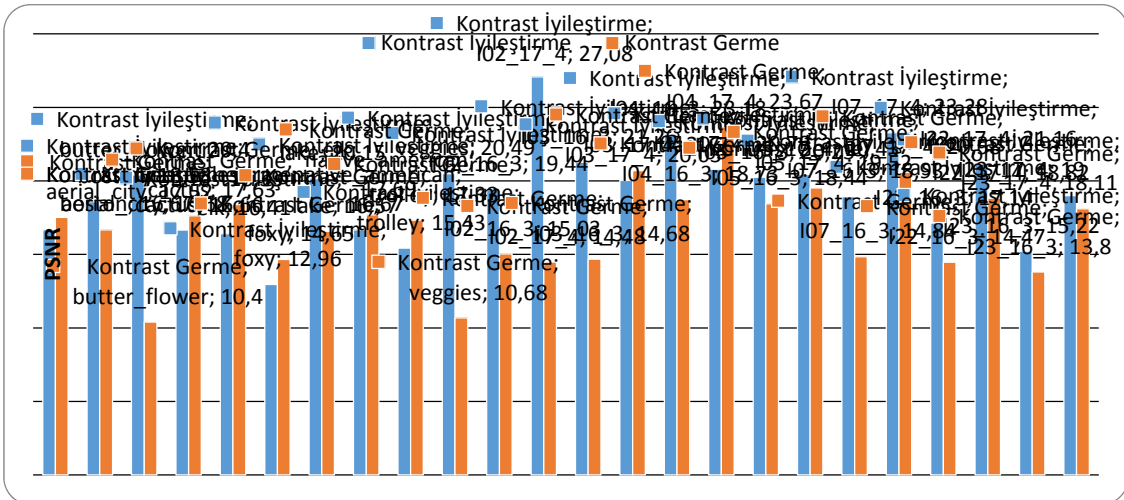

Şekil 3. Test Resimlerinin PSNR Değerlerinin Karşılaştırılması

Grafik incelendiğinde önerilen kontrast iyileştirme işleminin kontrast germeye göre daha iyi sonuçlar verdiği görülmektedir. 24 test resminden 16 tanesinde kontrast iyileştirme algoritması kontrast germeye göre daha iyi sonuçlar vermiştir. Kontrast germe işlemi, kontrast değeri iyi olan bazı resimlerin görüntüsünü bozduğu görülmüştür ancak geliştirilen kontrast iyileştirme algoritması iyi olan resimleri bozmamıştır.

SONUÇ

Bu çalışmada, interaktif, açık kaynaklı ve kullanıcı dostu grafik ara yüz gerçekleştirilmiştir. Uygulamadaki “Mean”, “Median”, “Std. Sapma”, “MSE”, “PSNR”, “SSIM”, “Alfa”, “Beta” ve “Gama” yazılarının yanlarındaki ? simgeleri ile işlemler hakkında bilgiler verilmektedir. Tasarlanan yazılım hem görüntü işleme aracı hem de kullanılan yöntemleri öğretici özellikte olması bu tür çalışmalara ilgi duyanlara kaynak olacaktır. Gelecek çalışmalarda, daha çok görüntü işleme ve yapay zekâ yöntemlerinin görsel olarak uygulamaya dâhil edilmesi planlanmaktadır.

KAYNAKLAR

- Gonzalez R. C., Woods R. E., 2007. Digital Image Processing (3rd Edition).
- Kennedy, J., Eberhart, R., (1995) Particle Swarm Optimization, *Proceedings of IEEE International Conference on Neural Networks*, (pp. 1942-1948), WA, USA.
- F. van den Bergh, “Particle Swarm Weight Initialization in Multilayer Perceptron Artificial Neural Networks”, In *Development and Practice of Artificial Intelligence Techniques*, pages 41-45. Durban, South Africa, September 1999.
- Ortakçı Y., Göloğlu C., (2012) Parçacık Sürü Optimizasyonu İle Küme Sayısının Belirlenmesi, Akademik Bilişim’12 - XIV. Akademik Bilişim Konferansı, Uşak Üniversitesi.
- Gözde H., Kocaarslan İ., Taplamacioğlu M.C., Çam E., (2008) İki Bölgeli Güç Sisteminde Parçacık Sürüsü Algoritması İle Yük-Frekans Kontrolü Optimizasyonu, *ELECO’08 Elektrik-Elektronik ve Bilgisayar Mühendisliği Sempozyumu*, (212-216), Bursa, Türkiye.
- Tamer S., Karakuzu C., (2006) Parçacık Sürüsü Optimizasyon Algoritması ve Benzetim Örnekleri, *ELECO 2006 Elektrik-Elektronik-Bilgisayar Sempozyumu, Elektronik Bildirileri Kitabı*, (302-306), Bursa, Türkiye.
- TID2008 image database page, 2014. <http://www.ponomarenko.info/tid2008.htm> (Erişim Tarihi: 25.04.2014).
- The CSIQ image database page, 2014. <http://vision.okstate.edu/?loc=csiq> (Erişim Tarihi: 25.04.2014).

TURKISH AND ISLAMIC SCIENTISTS IN TURKISH SCIENCE TEXTBOOKS

Şahin İDİN

Yalçın YALAKİ

The purpose of this study was to investigate the proportion of Turkish and Islamic scientists, who had significant contributions to science in history, that were mentioned in textbooks based on the current and past science and technology curriculums. For this purpose, science textbooks that were prepared based on the 1994, 2000, 2005, and 2013 National Science / Science and Technology Curriculums were investigated. One of the qualitative techniques, document analysis was used for data collection and analysis. Results showed that very few Turkish and Islamic scientists were mentioned in science textbooks, if any. We argue that more Turkish and Islamic scientists should be mentioned in science textbooks in a Turkish and Islamic state. We made suggestions on which Turkish and Islamic scientist may be mentioned in which textbook unit and how they should be mentioned as a conclusion.

Keywords: Turkish Islamic scientists, science text book

BİLGİSAYAR DESTEKLİ ÖĞRETİMİN LINEER BAĞIMSIZLIK KONUSUNDA AKADEMİK BAŞARI ÜZERİNE ETKİSİ

THE EFFECT OF COMPUTER ASSISTED INSTRUCTION ON ACADEMIC ACHIEVEMENT IN LINEAR INDEPENDENCE ISSUE

Osman KAN
Necmettin Erbakan University
osman-kan@hotmail.com

Süleyman SOLAK
Necmettin Erbakan University
ssolak42@yahoo.com

ÖZET: Bu çalışmanın amacı, bilgisayar destekli öğretimin Lineer Cebir dersine ait Lineer Bağımsızlık konusunda akademik başarı üzerine etkisini incelemektir. Çalışma, 2013-2014 eğitim-öğretim yılında bir devlet üniversitesinin İlköğretim Matematik Öğretmenliği programının 2.sınıfına kayıtlı 68 öğretmen adayı ile gerçekleştirilmiştir. Bu araştırmada, araştırma yöntemlerinden ön test-son test kontrol gruplu yarı deneysel desenlerden eşleştirilmiş desen uygulanmıştır. Uygulama boyunca Lineer Cebir dersine ait Vektörler, Matris Cebiri, Lineer Denklem Sistemleri ve Lineer Bağımlılık-Bağımsızlık konuları kontrol grubunda geleneksel yöntemlerle anlatılırken deney grubuna Geogebra yazılımı kullanılarak cebirsel kavramların geometrik temsilleri ve bu kavramların birbirleri ile ilişkisi üzerine hazırlanmış etkinlikler aracılığıyla interaktif uygulamalarla işlenmiştir. Bu çalışmada ölçme aracı olarak araştırmacı tarafından geliştirilen Lineer Cebir Başarı Testi hem ön test hem de son test olarak kullanılmıştır. Lineer Cebir Başarı Testindeki Lineer Bağımsızlık ile ilgili sorulara ilişkin test puanları Mann Whitney U testi kullanılarak analiz edilmiş ve deney grubu lehine anlamlı bir fark ($Z=-4.138$, $p<.001$) bulunmuştur. Deney grubunun sıralama puanlarının ortalaması 43.97 iken kontrol grubunun sıralama puanları ortalaması 25.03 olarak bulunmuştur. Burada $Z=-4,138$ olması kontrol grubunun erişim puanlarının sıralama puanlarının ortalamasının 4 standart puan altında olduğunu, $p<.001$ olması da bu farkın şans eseri olma ihtimalinin .001'den daha az olduğunu gösterir. Bu durum bilgisayar destekli öğretimin lineer cebir dersine ait lineer bağımsızlık konusunda akademik başarı üzerine olumlu bir etki yaptığını gösterir.

Anahtar sözcükler: Lineer Cebir, Lineer Bağımsızlık, Geometrik temsil, Germe.

ABSTRACT: This study was conducted to investigate the effects of computer assisted instruction on academic achievement in Linear Independence issue. The sample consists of 68 second grade elementary mathematics preservice teachers from a state university. The study's design is the matching only design from pretest – posttest quasi-experimental designs with control group. In this study a researcher-made questionnaire LCBT was applied as pretest and posttest. During the research, while vector, matrix, systems of linear equations and linear independence issues of Linear Algebra was taught in traditional methods in control group, geometric representations of these algebraic concepts and relationships between them were taught with interactive GeoGebra worksheets in experimental group. The test scores of questions related to the Linear Independence in LCBT was analysed with Mann-Whitney U test and significant difference ($Z=-4.138$, $p<.001$) was found between groups in favour of experimental group. This result shows that the computer assisted instruction affects academic achievement positively in linear independence issue.

Key words: Linear Algebra, Linear Independence, Geometric Representation, Span

LİSE ÖĞRENCİLERİNİN MATEMATİK DERSİNDE ÖĞRENME STİLLERİNE GÖRE UYGULANAN ETKİNLİK TÜRLERİNE YÖNELİK TERCİHLERİ

HIGH SCHOOL STUDENTS' PREFERENCES for ACTIVITY TYPES which is APPLIED at MATHEMATICS COURSE ACCORDING to LEARNING STYLES

Kemal ÖZGEN
Dicle Üniversitesi
ozgenkema@gmail.com

ÖZET: Bu çalışmanın amacı, lise öğrencilerinin matematik dersinde öğrenme stillerine göre uygulanan etkinlik türlerine yönelik tercihlerini incelemektir. Bu çalışmada fonksiyon ve türev kavramlarının öğrenimi sürecinde, yapılandırmacı öğrenme yaklaşımı kapsamında, McCarthy'nin 8 aşamalı 4MAT sistemi benimsenerek öğrencilerin öğrenme stillerine uygun öğrenme etkinlikleri geliştirilmiş ve uygulanmıştır. Uygulama sonrasında öğrencilerin etkinlik tercihlerine yönelik görüşleri belirlenmiştir. Araştırmanın çalışma grubu, bir devlet lisesindeki 19 öğrenciden oluşmaktadır. Kişisel bilgi formu, öğrenme stili ölçeği ve öğrenme etkinliklerine yönelik tercih ölçeği veri toplama araçları ile veriler toplanmıştır. Elde edilen nicel verilerin analizinde betimsel ve parametrik olmayan istatistiksel analizler kullanılmıştır. Verilerin analizi sonucunda öğrencilerin öğrenme etkinliği türlerine yönelik görüşlerinin genelde olumlu olduğu belirlenmiştir. Ayrıca, öğrencilerin öğrenme stillerine göre öğrenme etkinliklerine yönelik tercihlerinin istatistiksel olarak anlamlı bir şekilde farklılaşmadığı saptanmıştır.

Anahtar sözcükler: matematik, etkinlik, öğrenme stili

ABSTRACT: The aim of this study was to investigate high school students' preferences for activity types which is applied at mathematics course according to students' learning styles. As part of the study, activities which were suitable to the students' learning styles were developed within constructivist learning approach in line with McCarthy's 4MAT system with 8 steps of learning and used for the learning of the concepts of function and derivative. After the experimental application, students' preferences about activity types were determined. The participants of the study were consisted 19 students at a state high school. Data were collected using data collection tools such as a personal information form, a learning styles scale and a preference scale for learning activities. Descriptive and non-parametric statistics were used for the analysis of quantitative data. Students' views on learning activities were generally positive. Moreover, students' preferences for learning activities in relation to their learning styles did not differ significantly.

Key words: mathematics, activity, learning style

GİRİŞ

Etkinlik, öğrenme-öğretme süreçlerinin temel yapı taşları olarak görülebilir. Diğer disiplinlerde ve özellikle matematik eğitiminde etkinliklerle öğrenme-öğretme süreci ve bunun öğrenmeye faydaları üzerinde ortak görüş birliğine ulaşılmıştır. Northcote et al. (2001) etkinlikleri öğrencilerin öğrenmelerini geliştirmede özel olarak tasarlanan görevlerdir diye tanımlamışlardır. Simon et al. (2010) ise etkinliği, öğrencilerin belirli bir matematiksel görevi başarmadaki girişimlerinde amaca yönelik zihinsel ve fiziksel eylem olarak tanımlamaktadırlar. Bunun yanında, Wasserman et al.(2007) etkinlik türlerini sınıflandırırken, yalnız sınıf içinde, yalnız sınıf dışında ve hem sınıf içi hem de sınıf dışında yapılabilen 50'den fazla etkinlik türü (sunum, beyin fırtınası, örnek olay, problem çözme, işbirlikli öğrenme, tartışma, laboratuvar, simülasyon, proje, kavram haritası, araştırma, inceleme, rol oynama, panel vb. etkinlikler) olduğunu belirtmişlerdir.

Değişik etkinlikler ve farklı yollarla öğrenme öğrencilere yardımcı olmalıdır (Stylianides & Stylianides, 2008). Öğrencilerin matematik yapma performansını geliştirmek için çok yönlü matematiksel etkinliklerle uğraşabilecekleri ortamlar oluşturulmalıdır (Henningsen & Stein, 1997). Bu tür matematiksel etkinlikler "matematiğin ne olduğu?" ve "matematik yapıyor olmanın neyi gerektirdiği?" konularında mesajları içermelidir (NCTM, 1991).

Wasserman et al. (2007) çalışmalarında, etkili öğrenme etkinliklerinin özellikleri arasında "farklı öğrenme stillerinin gereksinimlerini desteklemesine de" yer vermektedirler. Öğrenenlerin bireysel öğrenme stilleri ile uyum gösteren öğrenme etkinliklerinin öğrenenin başarısını arttırdığı ortaya konmaktadır (Dunn, Beaudry &

Klavas, 1990-91). Fer'e (2003) göre bu durum oldukça mantıklıdır çünkü her birey farklı öğrenme stiline sahiptir ve bazı etkinlikler bazı öğrenenler üstünde olumlu etkiye sahipken, diğerleri üstünde olumsuz etki oluşturabilmektedir.

Öte yandan öğretmenlerin yeterlikleri arasında da “*öğrenenlerin bireysel farklılıklarını göz önüne alma*” istenen yeterliklerden biri olarak görülmektedir ve gittikçe önem kazanmaktadır. Bu yaklaşım ile MEB'in (2008) hazırladığı öğretmenlik mesleği genel yeterlikleri arasında öğrenme etkinliklerine ve bireysel farklılıklara yönelik vurguların olduğu görülmektedir. Matematiği öğrenme-öğretme sürecinde öğrencilerin öğrenme stillerine uygun etkinliklerin geliştirilmesi ve uygulanmasının önemli olduğu ortaya çıkmaktadır. Böyle bir yaklaşım ile farklı öğrenme etkinlik türleri ile matematik öğrenme sürecinin geliştirilmesi kaçınılmazdır. Farklı öğrenme stillerine sahip öğrencilerin etkinlik türlerine yönelik tercihlerinin belirlenmesinin önemli olduğu düşünülmektedir. Bu araştırmanın amacı, lise öğrencilerinin matematik dersinde öğrenme stillerine göre uygulanan etkinlik türlerine yönelik tercihlerini incelemektir.

YÖNTEM

Bu çalışmada fonksiyon ve türev kavramlarının öğrenimi sürecinde, yapılandırmacı öğrenme yaklaşımı kapsamında, McCarthy'nin 8 aşamalı 4MAT sistemi benimsenerek öğrencilerin öğrenme stillerine uygun öğrenme etkinlikleri geliştirilmiş ve uygulanmıştır. Uygulama sonrasında öğrencilerin etkinlik tercihlerine yönelik görüşleri belirlenmiştir. Araştırmanın çalışma grubu, bir devlet lisesindeki 19 öğrenciden oluşmaktadır. Çalışma grubunun 12'si (%63,2) erkek ve 7'si (%36,8) bayan şeklindedir.

4MAT modeli bir öğrenme döngüsü ve dört öğrenme stilini temsil eden 4 çeyrekte oluşmaktadır. Her bir çeyrekte kendi içinde sağ/sol mod tercihleri gözetilen 2 aşamayı içermektedir. Çalışmada kullanılmak üzere geliştirilen öğrenme etkinlikleri bu kuramsal ilkelere bağlı kalarak uygulanmıştır. Başka bir deyişle her ana kavram için 1.Tip (hayal gücü yüksek olanlar), 2.Tip (analitik öğrenenler), 3.Tip (sağduyulu öğrenenler) ve 4.Tip (dinamik öğrenenler) öğrenenlere yönelik 8 aşamalı öğrenme döngüsüne uygun etkinlikler geliştirilmiştir. Etkinliklerin oluşturulması aşamasında her stilin ana öğeleri (örneğin 1.Tip öğrenenlerde, kendi yaşamından olay seçimi, ilişkilendirerek düşünme, tartışma açma, zihin haritaları vb.) öne çıkarılmıştır. Fonksiyon ve türev kavramlarının kritik noktaları belirlenmeye çalışılmıştır. Bu adımdan sonra belirlenen kritik noktalar çerçevesinde öğrenilmesi hedeflenen içerik 4MAT sistemindeki aşamalara, aşamaların karakteristik özelliklerine göre dağıtılmaya çalışılmıştır.

Veri Toplama Aracı

Öğrencilerin öğrenme stillerini belirlemek için McCarthy'nin geliştirdiği, Elçi (2008) tarafından Türkçe'ye çevirisi yapılmış ölçekten yararlanılmıştır. Öğrenme stilleri ölçeği iki bölümden oluşmaktadır. A bölümü, her biri 4 seçeneğe sahip 15 madde içermektedir. Öğrencilerden her bir maddenin altındaki 4 seçeneğe her birini kendilerine en çok uyanı “4” ve en az uyanı “1” ile göstermek üzere sıralamaları istenmektedir. Maddelerin altındaki dört seçeneğin her biri 4 öğrenme stiline karşılık gelmektedir. B bölümü ise her biri iki seçeneğe sahip 11 maddeden oluşmaktadır. Öğrencilerden her maddenin altındaki 2 seçeneğe kendilerine en uygun olanını işaretlemeleri istenmektedir. Maddenin altındaki iki seçenek “Yaparak” ve “İzleyerek” seçeneklerine karşılık gelmektedir. Öğrenme stilleri ölçeğinin Cronbach Alfa ölçüm güvenirliği katsayıları sırasıyla öğrenme stillerinin her biri için 0.74, 0.71, 0.73, 0.76 olarak hesaplanmıştır.

Öğrenme etkinliklerine yönelik tercihleri belirlemek için Özgen ve Alkan (2011) tarafından geliştirilen ve 21 maddeden oluşan “*öğrenme etkinliklerine yönelik tercih ölçeği*” kullanılmıştır. Ölçekte, bazı öğrenme etkinlik türleri sıralanmaktadır. Öğrencilerden sıralanan etkinlik türlerinden hangilerinin öğrenme süreçlerine katkı sağladığını belirtmeleri istenmiştir. Her bir maddede verilen öğrenme etkinliğinin, öğrenme süreçlerini tam etkilediğine inandıkları için “*Tamamen*”, kısmen etkili olduğuna inandıkları için “*Kısmen*” ve hiç etkili olmadığına inandıkları için “*Hiç*” seçeneklerinden birini işaretlemeleri istenmiştir. Madde içerikleri dikkate alınarak 1.faktöre “*uygulamaya yönelik etkinlikler*”, 2.faktöre “*birlikte çalışmaya yönelik etkinlikler*”, 3.faktöre “*olay ve olguyu tanıma ve planlamaya yönelik etkinlikler*”, 4.faktöre “*yapılan çalışmaların önceki çalışmalarla ilişkilendirmesine yönelik etkinlikler*”, 5.faktöre “*bilgilendirilmeye yönelik etkinlikler*” ve 6.faktöre “*geliştirmeye yönelik etkinlikler*” isimleri verilmiştir. Öğrenme etkinliklerine yönelik tercih ölçeğinin ölçüm güvenirlik katsayısı (Cronbach alfa) 0,82 olarak belirlenmiştir.

Verilerin Analizi

Elde edilen nicel verilerin analizinde betimsel ve parametrik olmayan istatistiksel analizler kullanılmıştır. Öğrenme stilleri ölçeğinin A bölümünde I., II., III. ve IV. Tip öğrenme stillerinin her birine yönelik 15 madde olumsuzdan olumluya “1,2,3 ve 4” olarak kodlanmıştır. Sonuçta her bir stil için alınabilecek en yüksek puan 60 ve en düşük 15 puan belirlenmiştir. Böylelikle bireyin baskın öğrenme stili bulunmaktadır. Araştırmanın

kapsamından dolayı B bölümü dikkate alınmamıştır. Öğrencilerin ölçekten aldıkları puanların öğrenme stillerine göre anlamlı farklılık gösterip göstermediğinin belirlenmesinde Kruskal-Wallis testi uygulanmıştır. Öğrenme etkinliklerine yönelik algılara ilişkin aritmetik ortalamaları yorumlarken, 1.00-1.66 arasındaki ortalama değerlerin “Düşük”, 1.67-2.33 “Orta” ve 2.34-3.00 “Üst”, düzeyde değer taşıdığı varsayılmıştır. Ölçekteki her bir maddeye ve tüm ölçeğe yönelik elde edilen ortalama puanların yüksek oluşu belirtilen öğrenme etkinliğine yönelik etkililik algısının ve o etkinliği tercih etme durumunun yüksek olduğu şeklinde yorumlanmıştır.

BULGULAR

Tablo 1. Öğrenme Stiline Göre Etkinlik Tercihlerine Yönelik Betimsel İstatistiksel Bilgiler

Etkinlikler	Öğrenme Stili									
	1.Tip (n=2)		2.Tip (n=5)		3. Tip (n=8)		4.Tip (n=4)		Toplam (n=19)	
	\bar{X}	SS	\bar{X}	SS	\bar{X}	SS	\bar{X}	SS	\bar{X}	SS
Hedef sınavlar	2,00	1,41	1,80	,44	2,37	,51	2,50	1,00	2,21	,71
Problem çözerek öğrenme	3,00	,00	2,80	,44	2,87	,35	2,50	1,00	2,78	,53
1.Faktör										
Örnekler	3,00	,00	2,60	,54	2,87	,35	2,50	,57	2,73	,45
Çalışma yaprakları	3,00	,00	2,20	,44	2,62	,51	2,00	,81	2,42	,60
Konu testleri	2,50	,70	2,00	,70	2,37	,51	2,50	,57	2,31	,58
Kitaptan örnek problemler	3,00	,00	2,20	,44	2,50	,53	2,50	,57	2,47	,51
2.Faktör										
Sınıf tartışması	2,50	,70	2,20	,44	2,75	,46	2,50	,57	2,52	,51
Beyin fırtınası	3,00	,00	2,60	,54	2,87	,35	3,00	,00	2,84	,37
Grupla problem çözme	3,00	,00	2,20	,44	2,75	,46	3,00	,00	2,68	,47
Grup tartışması	3,00	,00	2,20	,44	2,50	,53	2,75	,50	2,52	,51
3.Faktör										
Sunum	2,50	,70	2,20	,83	2,12	,35	2,50	,57	2,26	,56
Öğrenci sunumları	2,50	,70	2,40	,54	2,12	,64	1,75	,95	2,15	,68
Model oluşturma	3,00	,00	2,80	,44	2,75	,46	2,25	,95	2,68	,58
Projeler	3,00	,00	2,80	,44	2,50	,53	2,25	,95	2,57	,60
4.Faktör										
Kütüphane araştırmaları	3,00	,00	2,60	,54	2,50	,53	2,50	,57	2,57	,50
Bireysel raporlar	2,50	,70	2,60	,54	2,37	,51	2,25	,50	2,42	,50
Grupla proje raporu	3,00	,00	2,00	,70	2,50	,53	2,75	,50	2,47	,61
5.Faktör										
Uzman toplantıları	3,00	,00	2,20	,83	2,37	,51	2,75	,50	2,47	,61
Geniş seminerler	3,00	,00	2,40	,89	2,25	,70	2,75	,50	2,47	,69
6.Faktör										
Benzetimler	3,00	,00	2,40	,54	2,75	,46	2,50	1,00	2,63	,59
Rol oynama	3,00	,00	2,60	,89	2,37	,51	2,00	,81	2,42	,69

Ölçeğin her bir maddesine ait genel ortalamalara göre öğrenciler “konu testleri, hedef sınavlar, sunum, öğrenci sunumları” gibi öğrenme etkinliklerini “orta” düzeyde ve geriye kalan öğrenme etkinliklerinin “üst” düzeyde etkili bulmaktadırlar. Buna karşılık öğrenme etkinlikleri ortalamaların hiçbiri, “düşük” düzeyde kalmamaktadır. En yüksek ortalamayı “beyin fırtınası” öğrenme etkinliği alırken en düşük ortalama “öğrenci sunumları” öğrenme etkinliği türündedir. Öğrenme etkinliği türlerinin çoğunda, 1.Tip öğrenenlerin ortalamaları en üst düzeydedir. Buna karşılık, “bireysel raporlar” öğrenme etkinliği türünde, 2. Tip öğrenenlerin ortalamaları en yüksektir. Öte yandan “sınıf tartışması” öğrenme etkinliği türünde 3. Tip öğrenenler en yüksek tercihi kullanmışlardır. “Hedef sınavlar” öğrenme etkinliği türünde 4. Tip öğrenenlerin ortalamalarının ve “konu testleri, beyin fırtınası, grupla problem çözme, sunum” gibi öğrenme etkinliği türlerinde 1. Tip ve 4. Tip öğrenenlerin ortalamalarının en yüksek olduğu görülmektedir.

Belirtilen öğrenme etkinliklerini, 1. Tip öğrenenlerin en çok ve 2. Tip öğrenenlerin en az etkili bulduğu söylenebilir. Buna ek olarak öğrenme stillerine göre faktörlerden alınan ortalama puanlar, tüm faktörlerde 1.Tip öğrenenlerin en üst düzeyde olduğunu göstermektedir. 1, 2, 4 ve 5. faktörlerde 2. Tip öğrenenlerin ortalama puanları ve 3 ve 6. faktörlerde 4. Tip öğrenenlerin ortalama puanları en düşüktür. 1. Tip ve 4. Tip öğrenenlerin diğer öğrenenlere göre öğrenme etkinliklerini daha etkili buldukları ve tercih ettikleri söylenebilir.

Öğrenciler, öğrenme etkinliklerine yönelik tercih ölçeğinin alt faktörlerinde ve ölçeğin tümünde, öğrenme stillerine göre anlamlı şekilde farklılaşmamaktadırlar. Gruplara ilişkin sıra ortalamalarında farklılıklar olmasına

rağmen, bu fark istatistiksel olarak anlamlı değildir. Bu bulgu öğrenme stiline, öğrencilerin öğrenme etkinliklerine yönelik tercihlerinde benzer etkilere sahip olduğunu gösterir.

Tablo 2. Etkinlik Tercihlerine Yönelik Puanların Öğrenme Stiline Göre Kruskal Wallis Testi Sonuçları

Faktör	Öğrenme Stili	n	Sıra Ort.	Sd	χ^2	p
1.Faktör	1. Tip	2	14,00	3	4,159	,245
	2. Tip	5	6,00			
	3. Tip	8	11,44			
	4. Tip	4	10,13			
2.Faktör	1. Tip	2	13,25	3	6,806	,078
	2. Tip	5	4,70			
	3. Tip	8	11,25			
	4. Tip	4	12,50			
3.Faktör	1. Tip	2	13,75	3	1,909	,591
	2. Tip	5	11,50			
	3. Tip	8	8,88			
	4. Tip	4	8,50			
4.Faktör	1. Tip	2	14,50	3	1,673	,643
	2. Tip	5	8,80			
	3. Tip	8	9,56			
	4. Tip	4	10,13			
5.Faktör	1. Tip	2	15,00	3	3,908	,272
	2. Tip	5	9,00			
	3. Tip	8	8,13			
	4. Tip	4	12,50			
6.Faktör	1. Tip	2	15,50	3	2,722	,436
	2. Tip	5	9,80			
	3. Tip	8	8,13			
	4. Tip	4	12,50			
Tüm ölçek	1. Tip	2	15,25	3	3,512	,369
	2. Tip	5	7,10			
	3. Tip	8	10,25			
	4. Tip	4	10,50			

TARTIŞMA, SONUÇ VE ÖNERİLER

Etkinliklere yönelik tercih ölçeğindeki öğrenme etkinliği türlerine yönelik görüşlerin genelde olumlu olduğu görülmektedir. Hiçbir etkinlik türüne yönelik ortalama puanların düşük düzeyde olmadığını görmek olumlu bir sonuçtur. Gerçekte öğrenciler, bazı etkinlik türleri dışında kalan, tüm öğrenme etkinliklerini üst düzeyde etkili bulmuşlardır. Ayrıca öğrencilerin “*beyin fırtınası, problem çözerek öğrenme*” gibi etkinliklere üst düzeyde tercih yönelmeleri düşünce üretmeye yönelmeye başladıklarını gösterir. Öğrenme etkinliği türlerinin birçoğunda 1.Tip öğrenenlerin ortalamalarının en yüksek düzeyde iken 2. Tip öğrenenler birçok öğrenme etkinliği türlerinde en düşük ortalamaya sahiptir. Ölçek maddelerinin ortalama puanlarına göre öğrenciler, öğrenme stillerine göre benzer görüşlerde birleşmektedir. Geliştirilmiş her öğrenme etkinliği için öğrenci tercihleri orta ve üst düzeydedir.

Önceki çalışmalarda, bazı öğrenme etkinliklerinin belirli öğrenme stiline öğrencilerce daha uygun bulunduğunu göstermektedir. Başka bir deyişle öğrenciler öğrenmede bu etkinlikleri tercih etmektedirler (Fer, 2003; Svinicki & Dixon, 1987). Bizim çalışma sonuçlarımız da buradakilerle benzerlik göstermektedir. Bazı etkinliklerle ilgili belli bir öğrenme stiline öğrenciler bir adım daha önde görülmektedir. Buna rağmen, öğrenme etkinliklerinin tümünde belirli bir öğrenme stiline yönelik kesin sınırları çizilebilen bir eşleştirme ya da sınıflamanın yapılması güçtür. Çünkü bazı etkinlikler (beyin fırtınası, problem çözerek öğrenme gibi), tüm öğrenme stillerindeki öğrencilerce üst düzeyde etkili bulunmuşlardır. Bergsteiner, Avery & Neumann (2010), bu durum ile ilgili olarak Kolb’un yaşantısal öğrenme modelini, öğrenme etkinlikleri bazında eleştirmektedirler. Bu modeldeki öğrenme stilleri ile öğrenme etkinlikleri arasında uygun farklılaştırma yapmanın başarısız girişim olduğunu belirtmişlerdir. Ayrıca, bazı etkinliklerin birden çok öğrenme stili ile bağlantılı olabileceğini (laboratuvar, sunum...) ve bir öğrenme etkinliği birçok öğrenme deneyimi içermesi durumunda belirli bir etkinliği bir öğrenme stili ile eşleştirmenin güç olacağını belirtmişlerdir.

Öğrencilerin öğrenme etkinliklerine yönelik tercih ölçeğinin alt faktörleri ve ölçeğin tümünde, öğrenme stillerine göre anlamlı bir şekilde farklılaşmadığı saptanmıştır. Başka bir deyişle öğrenme stili, öğrencilerin öğrenme etkinliklerine yönelik tercihlerinde benzer etkilere sahiptir. Bu istenen ve arzu edilen olumlu bir sonuçtur. Çünkü bu sonuca göre uygulanan 4MAT sistemi ve ona uygun öğrenme etkinlikleri, öğrencilerin hem kendi öğrenme stillerine uygun öğrenme etkinlikleri hem de diğer stillere uygun etkinliklerde deneyim kazanmasına fırsat sağlamıştır. Bu nedenle tüm öğrenme stillerindeki öğrenenler, 4MAT sistemine uygun hazırlanan etkinlikler ile öğrenmeyi kolaylaştırma fırsatlarından yararlanmışlardır.

Önceki çalışmalarda, öğrenme stili ve etkinlik tercihleri arasında anlamlı ilişkiler (Fer, 2003; Schaller et al., 2007) ve zayıf ilişkiler (Loo, 2004) ve güçlü olmayan ilişkiler (Sadler-Smith, 1997) olduğunu belirten araştırmalara rastlanmaktadır. Ayrıca Fer (2003) matematik, fizik ve kimya öğretmenliği öğrencilerinin öğrenme stilleri ile kolay öğrendikleri öğrenme etkinlikleri arasında anlamlı bir ilişki olduğunu ve öğrenme stili boyutlarının çoğunda ilk tercih edilen etkinliğin geleneksel bir yöntem olan anlatım, ikincisi beyin fırtınası olduğunu belirtmiştir. Bu sonuçlar bizim bulgularımız ile tam olarak uyuşmamaktadır. Çünkü bizim araştırmamızda öğrenenler beyin fırtınasını üst düzeyde etkili bulurken sunuma dayalı etkinlikleri daha düşük düzeyde etkili bulmuşlardır.

Tüm öğrenme stili modellerinde olduğu gibi McCarthy öğrenme stili modelinde de farklı öğrenme tercihlerinin (somut yaşantı, yansıtıcı gözlem, soyut kavramsallaştırma, aktif yaşantı) olduğu görülmektedir. Bu tercihlerin bileşimi bireyin öğrenme stilini belirtmektedir. Öğrenme stiline bu karmaşık yapının öğrenme etkinliklerine yönelik tercihlere de yansımaları benimsememiz gerekir. Çünkü öğrenme tercihlerinin ve stillerinin statik ve tek yapıldığı görüşü bizim araştırma bulguları ile de uyuşmamaktadır. Doğru olan öğrencilerin çoklu tercihlerle öğrendikleri ilkesini (Karns, 2006) benimsemektir. Ancak öğrenenlerin tercih ettikleri stile uygun öğretim yöntemleri ile daha iyi öğrendikleri bir gerçektir. Tüm öğrenme stillerini kapsayan 4MAT sistemi gibi modellere uygun öğrenme etkinlikleri benimsenmelidir. Bu doğrultuda, Loo (2004), belirli öğrenme stillerine belirli öğrenme yöntemlerini kullanma yerine çok çeşitli öğrenme yöntemleri kullanılması ve öğrencilerin bu yöne çekilmesi gerekir tezini savunmaktadır. Benzer şekilde Wasserman et al. (2007) öğrenme etkinliklerinde, çoklu öğrenme stillerinin tercih edilmesi ve tüm öğrenme stillerini kapsayan öğrenme etkinliklerinden yararlanılması vurgulamaktadır.

Matematik eğitiminde farklı etkinlik türlerinin kullanımı daha çok benimsenmeli ve öğrenciler bu yöne yönlendirilmelidir. Matematik öğretmenleri öğrencilerinin öğrenme stillerine göre farklı etkinlikler ile öğrenme süreçlerini yönlendirebilmelidirler. Öğrenciler böyle bir yaklaşım ile öğrenme açısından birçok olumlu fırsat sahip olabilir ve öğrenmeler kolaylaşabilir.

KAYNAKLAR

- Bergsteiner, H., Avery, G.C. & Neumann, R. (2010). Kolb's experiential learning model: Critique from a modelling perspective. *Studies in Continuing Education*, 32(1), 29-46.
- Dunn, R., Beaudry, J.S., & Klavas, A. (1990-91). Survey of research on learning styles. *Educational Psychology* 90/91, Annual Editions, 112-121.
- Elçi, A.N. (2008). Öğrenme stillerine uygun olarak seçilen öğrenme yöntemlerinin öğrencinin başarısına, matematiğe yönelik tutumuna ve kaygısına etkileri. Yayınlanmamış Doktora Tezi, Dokuz Eylül Üniversitesi Eğitim Bilimleri Enstitüsü, İzmir.
- Fer, S. (2003). Matematik, Fizik ve Kimya öğretmenliği öğrencilerinin öğrenme biçimlerine göre kolay öğrendikleri öğrenme etkinlikleri. *Çağdaş Eğitim Dergisi*, 28 (304), 33-44.
- Henningsen, M., & Stein, M.K. (1997). Mathematical tasks and student cognition: Classroom-based factors that support and inhibit high-level mathematical thinking and reasoning. *Journal for Research in Mathematics Education*, 28 (5), 524-549.
- Karns, G.L. (2006). Learning style differences in the perceived effectiveness of learning activities. *Journal of Marketing Education*, 28(1), 56-63.
- Loo, R. (2004). Kolb's learning styles and learning preferences: Is there a linkage? *Educational Psychology*, 24(1), 99-108.
- Milli Eğitim Bakanlığı [MEB]. (2008). *Öğretmenlik mesleği genel yeterlikleri*. 1-38. <http://otmg.meb.gov.tr/YetGenel.html> adresinden 08 Mayıs 2011 tarihinde edinilmiştir.
- National Council of Teachers of Mathematics [NCTM]. (1991). *Professional standards for teaching mathematics*. Reston, VA: Author.
- Northcote, M., Kendle, A., Ingram, D., and Thompson, E. (2001). Activities for learning. Practical advice for enhancing your teaching and learning. Retrieved April 13, 2011 from <http://www.catl.uwa.edu.au/resources/advice.html>.
- Özgen, K. ve Alkan, H. (2011). Matematik öğretmen adaylarının öğrenme stiline göre etkinliklere yönelik tercih ve görüşlerinin incelenmesi. *Hacettepe Üniversitesi Eğitim Fakültesi Dergisi*, 41, 325-338.
- Sadler-Smith, E. (1997). Learning style: Frameworks and instruments. *Educational Psychology*, 17(1-2), 51-63.

- Schaller, T.D., et al., (2007). One size does not fit all: Learning style, play, and online interactives. In J. Trant and D. Bearman (Ed.). *Museums and the Web 2007: Proceedings*, Toronto: Archives & Museums Informatics. Retrieved May 3, 2011 from <http://www.archimuse.com/mw2007/papers/schaller/schaller.html>.
- Simon, M., et al. (2010). A developing approach to studying students' learning through their mathematical activity. *Cognition and Instruction*, 28(1), 70-112.
- Stylianides, A.J. & Stylianides, G.J. (2008). Studying the classroom implementation of tasks: High-level mathematical tasks embedded in real life contexts. *Teaching and Teacher Education*, 24 (4), 859-875.
- Svinicki, M.D. & Dixon, N.M. (1987). The Kolb model modified for classroom activities. *College Teaching*, 35(4), 141-146.
- Wassermann, J., Davis, C., & Astrab, D.P. (2007). Overview of learning activities. 1-8. Activity design handbook. faculty guidebook. Lisle: Pacific Crest. Retrieved April 27, 2011 from www.pcrest.com

AN ANALYSIS OF NUMBER SENSE OF THE HIGH-ACHIEVING HIGH SCHOOL STUDENTS

Sare ŐENGÜL

Hande GÜLBAĖCI DEDE

Mehmet ÖZCAN

Number sense is described as having a good understanding with the numbers and operations and also using this understanding flexibly and effectively in mathematical situations. Students with good number sense can use numbers and operations flexibly, have mental computation and estimation ability, recognize the relative effect of operation on numbers, develop benchmarks. The earlier studies about number sense show that students have an inclination to use rule based methods and standard written algorithms and generally have low number sense. The aim of this study is to find out the number sense of high school students who are high-achieving. 112 students (54 girls, 58 boys) from public science high school in Istanbul participated the study. As an instrument, multiple-choice test including 12 number sense problems is used. Three components of number sense were included in the test. These are; understanding the meaning of the numbers, recognizing relative number size and judging the reasonableness of computational results. Each participant is given the number sense test and asked to explain their solution strategy in written form. In data analysis, the answers of the problems are analyzed in both mathematical correctness and solution strategy (number sense strategy or rule-based strategy). According to the analysis, the success of the students in the number sense test was %87.5 and 66% of the solutions included number sense aspects. The results of this study showed that high-achieving high school students can use number sense strategies efficiently.

Keywords: number sense, number sense strategy, high-achieving

ODAK GRUP GÖRÜŞMESİ İLE KÜTLE VE AĞIRLIK KAVRAMLARININ ÖĞRETİMİ

TEACHING OF MASS AND WEIGHT CONCEPTS THROUGH FOCUS GROUP INTERVIEWS

Mehmet ÖZ

Niğde Üniversitesi Eğitim Fakültesi İlköğretim Bölümü Fen Bilgisi Eğitimi ABD
mehmetoz91@hotmail.com

Gökhan ÖZDEMİR

Niğde Üniversitesi Eğitim Fakültesi İlköğretim Bölümü Fen Bilgisi Eğitimi ABD
gokhanozdemir@nigde.edu.tr

ÖZET: Bu çalışmanın amacı öğrencilerin “Kütle ve Ağırlık” konusundaki kavram yanlışlarını tespit etmek ve bu kavram yanlışlarını kavram karikatürlerinin kullanıldığı odak grup görüşmesi ile gidermektir. Bu çalışmanın örneklemini ilköğretim düzeyinde beş sekizinci sınıf öğrencisi, üç de yedinci sınıf öğrencisi olmak üzere toplam sekiz öğrenci oluşturmaktadır. Çalışmada öğrencilerin kavram yanlışlarını tespit etmek için açık uçlu ve çoktan seçmeli ön test uygulanmıştır. Ön testten elde edilen veriler ışığında öğrencilerin kavram yanlışlarını içeren kavram karikatürleri hazırlanmıştır. Daha sonra odak grup görüşmesi yoluyla öğrencilerin kavram yanlışları giderilmeye çalışılmıştır. Bu uygulamaların sonucunda öğrencilerin “Kütle ve Ağırlık” kavramına ilişkin yeni anlayışları oluşturdukları kavram haritası ile değerlendirilmiştir. Araştırma sonuçları göstermiştir ki odak grup görüşmesi ile kavram karikatürlerinin birlikte uygulanması öğrencilerin “Kütle ve Ağırlık” anlayışlarını önemli ölçüde düzeltmiştir.

Anahtar sözcükler: kütle ve ağırlık, kavram karikatürleri, kavram haritası ve odak grup görüşmesi

ABSTRACT: The purpose of this study is to determine students' misconceptions for the concepts of mass and weights and to remedy these misconceptions in a focus group interviews employed concept caricatures. The sample of the study consists of five of eighth grade and three of seventh grade students. As a pre test, a set of open ended questions and multiple choice test was administered to determine students' misconceptions. In light of pre-test results, a set of concept caricatured were prepared comprising students' misconceptions about mass and weight. At the end, it was tried that students' misconceptions would disappear through focus group interviews. After these applications, the students' new understandings were assessed by their concept maps about mass and weight. The results of the study indicated that combining focus group interviews and concept caricatures in teaching pretty much enhanced students' understandings in the concept of mass and weight.

Key words: mass and weight, concept caricatures, concept map, and focus group interviews

FEN VE TEKNOLOJİ ÖĞRETMENLERİN TEKNOLOJİ DOĞASI HAKKINDAKİ DÜŞÜNCELERİ

Yrd. Doç. Dr. Sinan ÇINAR
Recep Tayyip Erdoğan Üniversitesi Eğitim Fakültesi
sinan.cinar@erdogan.edu.tr

Bu çalışmanın amacı fen ve teknoloji öğretmenlerin teknolojinin doğası ve fen ve toplumla olan ilişkisi hakkında görüşlerini ortaya çıkarmaktır. Araştırma var olan durumu betimleme amacı taşıdığından araştırma yöntemi olarak özel durumu çalışması benimsenmiştir. Araştırmanın örneklem grubunu Recep Tayyip Erdoğan Üniversitesi Eğitim Fakültesinde öğrenim göre 100 fen ve teknoloji öğretmen adayları oluşturmaktadır. Örnek grubunda veriler anket ve mülakat teknikleri kullanarak toplanmıştır. Anket verileri yüzdelik olarak analiz edilirken ve mülakat verilerinde içerik analiz tekniği kullanılmıştır. Araştırmada kullanılan Teknoloji Doğası Anketi- TDA, View on Science, Technology, Society-VOSTS anketinin adaptasyonundan elde edilmiştir. Anket beş alt kategori içermektedir; 1) teknolojinin tanımı, 2)teknolojinin fen ile olan ilişkisi, 3)toplumun teknoloji üzerine etkisi, 4) teknolojinin toplum üzerine etkisi ve 5)teknolojinin sosyal yapısı şeklindedir. Diğer bir veri toplama aracıda mülakattır; mülakat soruları anket sorularından elde edilen verilerin güvenilirliği sağlamak için 5 alt kategoriyi kapsayacak şekilde beş sorudan oluşmaktadır. Çalışmada elde edilen veriler; fen ve teknoloji öğretmen adaylarının teknolojiyi fennin uygulaması olarak tanımlamakta teknoloji ile fennin bir birinin aynı olduğu ve teknolojinin fenedeki bilgi yapısı üzerine geliştiğini savunmaktadır. Toplumun teknolojiyi sadece teknolojik çalışmaları maliyet bakımından destekleme boyutunda etkilediği, teknolojinin ise toplumu rahatlık, huzur ve ahlak gibi birçok yönden etkilediğini düşünmektedir. Teknolojik çalışmaların uygulanabilirliği hakkında ise kesinlikle bu duruma bilim adamlarının karar vermesi gerektiğini düşünmektedir. Mülakattan elde edilen verilerde bu durumu desteklemektedir. Yaşamımızın teknolojiye dayalı olduğu bu çağda öğretmen adaylarının özellikle fen ve teknoloji öğretmen adaylarının teknolojinin yapısı hakkında yeterli bilgiye sahip olmaması oldukça manidardır. Bu bağlamda fen ve teknoloji öğretmen hizmet öncesi ve hizmet-içi eğitim programlarına teknoloji ile ilgili derslerin ve seminerlerin düzenlenmesi ve koyulması gerekmektedir.

Anahtar sözcükler: fen ve teknoloji öğretmen adayları, teknolojinin doğası, fen ve teknoloji öğretimi

TURKISH PROSPECTIVE ELEMENTARY SCIENCE TEACHER'S VIEWS ABOUT NATURE OF TECHNOLOGY

Yrd. Doç. Dr. Sinan ÇINAR
Recep Tayyip Erdoğan Üniversitesi Eğitim Fakültesi
sinan.cinar@erdogan.edu.tr

Technology's effects on human life a new research area has occurred and attitudes towards technology have started to develop. It is related with the development in content knowledge to become a knowledge society technological literacy us defined as individual s' understanding, using, directing and evaluating technology. This study explores the Turkish prospective elementary science teachers' views of technological nature. We collected data from 100 prospective elementary science teachers. Data were collected using an adopted "Views on Science – Technology–Society (STS)" instrument. Analysis revealed that Turkish prospective elementary science teachers viewed technology as an application of science, and some viewed science as explanatory and an interpretation of nature. They viewed individual value and confidence more important than technological information and practice in decision making process interested to daily life.

Key words: Prospective Turkish elementary science teachers, nature of technology, science and technology teaching.

BİLGİSAYAR MÜHENDİSLİĞİNE GİRİŞ DERSİNE İLİŞKİN ÖĞRENCİ GÖRÜŞLERİNİN DEĞERLENDİRİLMESİ

Abdullah Erdal TÜMER
Necmettin Erbakan Üniversitesi Mühendislik ve Mimarlık Fakültesi
Bilgisayar Mühendisliği
tumer@konya.edu.tr

ÖZET: Bu araştırmada, Bilgisayar Mühendisliği bölümlerinin temel derslerinden olan Bilgisayar Mühendisliğine Giriş (BMG) dersine ilişkin öğrenci görüşlerinin belirlenmesi ve değerlendirilmesi amaçlanmıştır. Bu amaçla, Necmettin Erbakan Üniversitesi Mimarlık ve Mühendislik Fakültesi Bilgisayar Mühendisliği 1. Sınıf öğrencilerden bu dersi alanların derse ilişkin görüşlerinin belirlenmesi amacıyla nitel bir araştırma yapılmıştır. Bu kapsamda veriler, öğrencilerden açık uçlu sorularla toplanmıştır. Öğrencilerden elde edilen verilerin analizi betimsel analiz yoluyla yapılmıştır. Sonuç olarak, dersten başarılı olan öğrencilerin ilgili dersten genel olarak istifade ettiklerini ve diğer dönemlerde görecekları derslere bir ışık tuttuğunu belirtmişlerdir. Buna ek olarak, dersten başarılı olan öğrenciler BMG dersinin birçok açıdan yararlar sağladığı konusunda olumlu görüşler bildirmişlerdir. Dersten başarısız olan öğrencilerin ise zaten ileride ayrıntılı bir şekilde görecekları derslerin önceden kendilerine özet olarak sunulmasının gereksiz olduğunu belirtmişlerdir.

Anahtar sözcükler: bilgisayar mühendisliğine giriş, öğrenci görüşleri,

GİRİŞ

Bilgisayar Mühendisliğine Giriş dersi hemen hemen tüm mühendislik fakülteleri bilgisayar Mühendisliği bölüm öğrencilerine 1. Yarıyıl okutulan zorunlu bir derstir. Bu derste bilgisayar mühendislik programında alınması gereken ana derslere yönelik temel oluşturan ön bilgiler verilir. Bu dersler donanım, işletim sistemi, programlama, veri tabanı, ağ ve iletişim konuları gibi geniş bir yelpaze içerir. Bu dersin temel de iki amacı vardır: (i) öğrencilerin bilgisayar mühendisliği ve akademik temellerini güçlendirmek ve (ii) daha sonraki yıllarda alınacak derslerde başarının kolaylaştırılmasıdır (Hsien-Tsai et al., 2014). Bu amacın gerçekleştirilebilmesi için bu dersi alan öğrencilerin derse ilişkin görüşlerinin bilinmesi birçok açıdan gereklidir. Çünkü her hangi bir derse karşı öğrencilerin görüşleri, tutumları akademik başarılarını büyük ölçüde etkilemektedir (Başer & Geban, 2007; Gagne 1992).

Bilgisayar Mühendisliğine Giriş Dersi

Bilgisayar Mühendisliğine giriş dersinin kavramsal çerçevesinin özü 6 katmandan oluşmaktadır (şekil 1). Bu katmanlar en içte bilgi, donanım, programlama, işletim Sistemi, uygulamalar ve en dışta iletişim katmanı şeklindedir (Dale&Lewis, 2007). Bu katmanlarda bahsedilen konular da aşağıdaki gibidir:

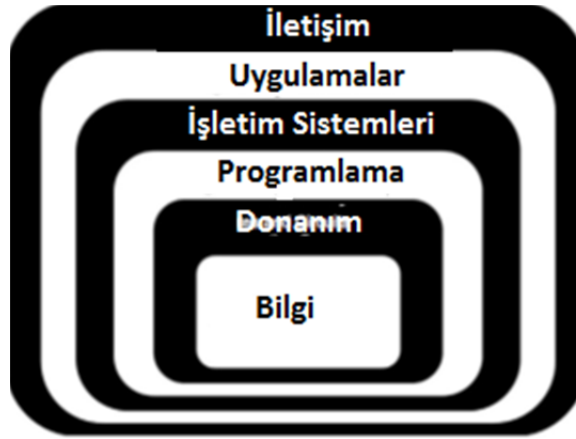

Şekil 1 Bilgisayar Mühendisliğine Giriş Dersi İçerik Katmanları

Bilgi Katmanı : Sayı sistemleri, dönüşümler, veri formatları ve sayı gösterimleri
Donanım Katmanı : Mantıksal Kapılar ve devreler, CPU ve Bellek, Giriş/Çıkış elemanları
İşletim Sistemi Katmanı : İşletim sistemleri, dosya sistemleri

Programlama Katmanı : Problem çözüme, Algoritma, düşük ve yüksek seviyeli programlama dilleri, soyut veri tipleri
Uygulama Katmanı : Bilgi sistemleri, Yapay zeka, Simülasyon, Grafikler
İletişim Katmanı : Ağlar ve Web teknolojileri

Bilgisayar mühendisliğine ait yukarıda katman ve içerikleri sunulan bu temel kavramlar, öğrencilerin daha iyi anlayabilmesi için uygulamalı örnekler eşliğinde slayt ve sözlü anlatım şeklinde sunulmuştur. Bu dersin değerlendirilmesi ödev (% 10), ara sınav (% 30) ve final (% 60) şeklinde yapılmıştır.

Sadece derse karşı tutumları değil öğretmenlerine yönelik tutumları da önemlidir. Ayrıca öğrencilerin derse anlama, başarıma noktasında gerekli bilgi veya belirli bir görevi gerçekleştirmek için gerekli becerilere sahip olabilirler. Ama kendinden şüphe, motivasyon eksikliği gibi faktörler nedeniyle de başarılı olmayabilirler. Bu ders çok geniş bir içeriğe sahip olduğundan tamamen anlaşılmasa, başarı elde edilememesi gibi ihtimal dahilinde zorluklar vardır (Merrick, 2010; Verginis et al., 2011). Bu ve benzeri zorlukları aşmak için literatürde çeşitli çalışmalar yapılmıştır (Koile & Singer, 2006; Merrick, 2010; Parhami, 2009; Verginis et al., 2011).

Bilgisayar Mühendisliğine Giriş dersini alan öğrencilerin görüşlerinde farklılıklar olması oldukça doğaldır. Bu farklı görüşlerin belirlenmesi, dersin öğretilmesi açısından oldukça önemlidir. Sadece dersin öğretilmesi değil derse alan öğrencinin motivasyonunu, ilgisini ve başarısını da etkileyeceği düşünülmüştür. Bu düşünceler doğrultusunda bu çalışmada bilgisayar mühendisliğinin 1. Yarıyılında okutulan Bilgisayar Mühendisliğine Giriş dersine yönelik öğrencilerin görüşleri alınarak var olan durumu ortaya koymak üzere bir açık uçlu sorular hazırlanmıştır. Açık sorular yardımıyla bu derse alan öğrencilerin görüşleri araştırılmıştır. Ayrıca literatür araştırmasında da derse karşı sınırlı sayıda yabancı çalışmalara rastlanılmıştır. Ancak ülkemizde böyle bir araştırmanın olmadığı tespit edilmiştir. Bu yüzden bu çalışmanın bu derse ait çalışmalara bir başlangıcı olacağı düşünülmektedir.

YÖNTEM

Araştırma Modeli

Bu çalışmada durum çalışması yöntemi kullanılmıştır. Yin'e (1984) göre durum çalışması, araştırılan olguyu kendi yaşam çerçevesi içinde inceleyen, olgu ve içinde bulunduğu ortam arasındaki sınırların kesin hatlarla belirgin olmadığı durumlarda kullanılan bir araştırma yöntemidir. Araştırmada toplanan veriler ise betimsel analiz yöntemi ile yapılmıştır. Bu analizde toplanan verinin orijinal halini mümkün olduğunca değiştirmeden ve gerektiğinde katılımcıların ifadelerinden doğrudan alıntı yapılarak betimsel bir yaklaşımla veriler paylaşılmıştır (Woncott, 1994).

Çalışma Grubu

Necmettin Erbakan Üniversitesi (NEÜ) 2010 yılında Konya'da kurulan üniversitelerden dördüncüsüdür. Mühendislik ve Mimarlık Fakültesi Bilgisayar Mühendisliği Bölümü ilk öğrencilerini 2013-2014 eğitim öğretim yılında almıştır. Bölümün amacı, sürekli iyileştirme ve değerlendirme yoluyla, öğrencilerini yazılım ve donanım alanında seçkin mühendisler olarak yetiştirmektir. Bu çalışma Bilgisayar Mühendisliği birinci sınıfta okuyan, haftalık ders saati 2 olan ve 14 hafta süren zorunlu BMG dersini alan 40 öğrenciden alınan görüşler doğrultusunda yapılmıştır. Ara sınavın % 40 'ı ve final sınavının % 60 alındığında en az ortalaması 60 puan ve üzerinde not alanlar bu dersten başarılı sayılmaktadır. Çalışmaya yaş ortalaması 19,5 olan 24 kız ve 16 erkek öğrenci katılmıştır.

Verilerin Toplanması

Öğrencilerin bilgisayar mühendisliğine giriş dersine ilişkin görüşlerini belirlemek amacıyla tarama modelinde 9 açık uçlu soru hazırlanmıştır. Bu sorular şu şekildedir:

- BMG dersi için seçilen konular hakkında ne düşünüyorsunuz?
- BMG dersi için beklentileriniz karşılandı mı?
- BMG dersinde hangi metotla anlatım size daha faydalı oldu?
- BMG dersine aktif katılabildiniz mi? Bunun size dönüşümü nasıl oldu?
- BMG dersinde en kolay anladığınız ve en zorlandığınız konu hangisi oldu?
- BMG dersinizin gelecekteki kariyerinize etkisini nasıl değerlendiriyorsunuz?
- BMG dersine ne kadar ilgilisiniz?
- BMG dersinin önünüzdeki 4 yıl boyunca alacağımız derslere bir fayda sağlayacağını düşünüyor musunuz? Neden?
- BMG dersinin hocası siz olsaydınız bu derse nasıl yürütürdünüz (içerik, anlatım metodu, ödev vs.)

Özgüven, 1998 ' e göre sorularhazırlandıktan sonra konu uzmanlarının görüşlerine başvurulması ve amaca uygun olup olmadığına ilişkin görüş alınması gerekir. Bu nedenle uzman eleştirileri doğrultusunda sorular yeniden düzenlenmiştir. Daha sonra, dersi alan öğrencilere sorular dağıtılarak görüşlerini yazmaları istenmiştir. Sorulara yazılan görüşlerin değerlendirilme aşamasında ise öğrencilerin bazı ifadelerine yer verilmiştir. Ayrıca veriler tablolaştırılmıştır.

BULGULAR VE YORUM

Araştırmaya katılan öğrencilere tarama modelinde hazırlanan sorular yöneltilmiştir. Elde edilen veriler çeşitli temalar etrafında düzenlenerek betimsel analize tabi tutulmuş ve aşağıdaki tabloda özetlenmiştir.

Aşağıdaki tablo 1 de görüleceği gibi dersten başarılı olan öğrencilerde daha sonraki derslere yönelik bir farkındalık oluştuğu, mesleki alanları ile ilgili geniş ve kapsamlı bilgi sahibi olduklarını belirtmişlerdir. Ayrıca, ders saatinin az olmasına rağmen beklentilerinin karşılandığını ifade etmişlerdir. Dersten başarılı olan öğrenciler, slaytlar eşliğinde anlatımla daha fazla konu işlendiğinden memnun olmakla beraber not alamadıklarını söylemişlerdir. Tahtanın daha etkin kullanılması gerektiğini vurgulamışlardır. Derse aktif katıldıklarını, buna bağlı olarak da sınavda başarılı olduklarını ifade etmişlerdir. Kolay ve zor öğrenilen konularda bir homojenliğin olmadığı tespit edilmiştir. Öğrenciler ilgi alanlarına göre farklı dersleri işaret etmişlerdir.

Tablo 1. Görüşmeden Elde Edilen Bulgular

Temalar	Dersten Başarılı Olan Öğrenciler	Dersten Başarısız Olan Öğrenciler
Seçilen Konular	Bütün dönemler boyunca işlenecek konular hakkında bir farkındalık oluşturdu. Branşımızı daha yakından tanımamızı sağlayan oldukça faydalı konulardı. Branşımızla ilgili merak ettiğim konular ve cevap bekleyen soruların artmış olması beni çok mutlu etti. Genel itibariyle iyi seçilmiş ve oldukça faydaladığımız konular vardı. Ama donanım konusuna biraz daha fazla değinilmeliydi.	Daha sonraki yıllarda ayrıntılı bir şekilde göreceğimiz konulardan şimdiden sorumlu tutulmam çok gereksiz. Konular fazlasıyla teorik, ayrıntılı ve ezbere dayalı idi. Dikkat çekici değildi. Kafamızdaki sorulara cevap veremedi. konular.
Beklentiler	Çok verimli geçen ama ders saati az olan, sadece tek dönemlik bir ders olması ve öğrenmemiz gereken konular fazla ayrıntıya girilmemesine rağmen beklentilerim büyük ölçüde karşılandı.	Konular çok soyut ve ezbere dayalı olduğundan genel itibariyle beklentilerimin karşılandığını düşünmüyorum. Bölümümüz için gerekli bir ders olarak görmüyorum.
Beğenilen Anlatım Metodu	Slaytlı anlatım daha çok konu işlememizi sağladı ama not alamadık. Tahtaya yazarak anlattıklarımızdan daha çok yararlandık. Hem not alabildik hem de daha aktif derse katılabildik. Görsel ve uygulamalı anlatılması daha iyi olacağı kanaatindeyim.	Slaytlı anlatım faydalı olmadı ve yetersizdi. Slaytları sizden alacağımız için not almadık ve tabii olarak hep uykumuz geldi. Donanım konusu daha görsel olabilirdi. Örnekler artırılmalıydı. Daha eğlenceli anlatılabilirdi. Tahta daha fazla kullanılması gerekirdi.
Akif Katılım	Derse aktif bir şekilde katıldım. Anlamam daha kolay oldu. Daha önce ne duyduğum ne gördüğüm pek çok konuyu öğrenmiş oldum. Katılmadığım zamanlarda dinlemeye çalıştım. Anlamadığım yerleri hemen sordum. Sınavda da faydasını gördüm.	Aktif katılamadım. Sadece dinledim. Sınavlara çalışmaya hiçbir bir şey bilmeden hazırlanmaya çalıştım. Ama başarılı olamadım.
En kolay Öğrenilen Konu	Boolean Cebri, İşletim Sistemleri, Mantık devreleri, giriş/çıkış sistemleri	Sayı Sistemleri
En Zor Öğrenilen Konu	Kayan noktalı sayılar, Veri Yapıları, Mantık devreleri, Bilgisayar ağları	Boolean Cebri, Bellek Haritaları,
Kariyere etki	Bu dersin meslek hayatımdaki kariyerime bir etkisi olabileceğini düşünmüyorum. Branşımızın kapsadığı konuları ve daha sonraki dönemlerde nelerle karşılaşacağımızı, hangi dersleri işleyeceğimizi öğrenmiş olduk.	Bu dersin kariyerime herhangi bir etkisini olacağını sanmıyorum.
Gelecekteki Derslere Fayda	Mesleğimiz hakkında genel bilgi sahibi olduk. Daha sonraki derslerin bir özeti mahiyetindeydi. Bazı kavramları önceden öğrenmiş olduğumuz için gelecekteki dersleri de faydasını olacaktır.	Bu dersin gelecekteki derslere fazla bir faydası olacağını düşünmüyorum. Çünkü o derslerde bu konular zaten tekrar anlatılacaktır. Sadece bazı şeyleri anımsatabilir.
Öğrenci önerileri	Öncelikle bu dersin 2 dönemde de olması ve ders saatinin artırılması önerirdim. Slaytla beraber önemli noktaları not aldırırdım. Her konu ile ilgili ödevler	Ben bu dersin hocası olsaydım önce bu dersin kaldırılmasını teklif ederdim. Kalkmazsa öğrencileri sınıfta daha aktif hale getirirdim. Onlara da ders

	verirdim. Uygulamalı yapardım. Dersin daha eğlenceli bir hale gelmesi için çaba sarf ederdim.	anlattırırdım. Soru-cevap ve karşılıklı tartışma yaptırırdım. Uygulama ortamı sağlardım.
--	---	--

Her ne kadar gelecek yıllarda alacakları derslere ciddi katkı sağlayacağını düşünseler de ilerideki kariyerlerine bir etkisi olmayacağını söylemişlerdir. Ders saatinin artırılması ve dersin 2 dönemde de okutulması gerektiğini vurgulamışlardır.

Bu dersi alıp ve başarısız olan öğrenciler genellikle dersle ilgili olumsuz görüşlerde bulunmuşlardır. Daha sonraki dönemlerde ayrıntılı işleyecekleri derslerin daha önceden sorumlu tutulmalarının yanlış olduğunu ve dersin kaldırılmasını talep etmişlerdir. Dersin ezbere dayalı olduğu gerekçesi ile aktif katılmadıklarını ve beklentilerinin karşılanmadığını vurgulamışlardır. Dersten başarılı olan öğrencilerle ortak düşünceleri ise (i) kolay ve zor öğrenilen konularda da bir homojenliğin olmadığı ve (ii) dersin kariyerlerine herhangi bir katkısının olmayacağı yönünde olmuştur.

SONUÇ VE ÖNERİLER

Bu çalışmada Necmettin Erbakan Üniversitesi Mühendislik ve Mimarlık Fakültesi Bilgisayar Mühendisliği 1. Sınıf öğrencilerinin Bilgisayar Mühendisliğine Giriş dersine yönelik öğrenci görüşleri dersten başarılı olan ve olmayanlara göre alınmıştır. Öğrencilere yöneltilen sorular uzman görüşü alındıktan sonra son şekli verilmiştir. Elde edilen bulgular dersten başarılı olan öğrencilerin bu dersi gerekli, yeterli, katkı sağlayıcı, slaytta anlatımın faydalı olduğu ve beklentilerinin karşılandığı yönünde olumlu görüş belirtmişlerdir. Bunun yanında başarılı öğrenciler ders saatinin az olması, sadece bir dönemlik ders olması, tahtanın etkin kullanılmadığı ve kariyerlerine bir etkisi olmayacağı yönünde de olumsuz görüş beyan etmişlerdir. Bu dersten başarısız olan öğrenciler de genellikle bu dersin ezberci ve gereksiz olduğunu, kaldırılması gerektiğini, beklentilerinin karşılanmadığını ve kariyerlerine bir etkisi olmadığını beyan etmişlerdir.

Bir ders ait olumsuz görüşler o derse olan başarıyı da olumsuz etkilemektedir. Bu yüzden öğrencilerin derse karşı olumsuz tutumlarının giderilmesinin yolları aranmalıdır. Derse sorumlularının slaytla beraber tahtayı da daha etkin kullanmaları gerekmektedir. Ayrıca ders saatinin en az 3 saat olarak belirlenmesi, derse aktif katılımın artması için ders öncesi hazırlık sorularının ders sonrası pekiştirici ödevlerin verilmesinin uygun olacağı düşünülmektedir.

KAYNAKLAR

- Başer M. , Geban Ö. (2007). “Effectiveness of Conceptual Change Instruction on Understanding of Heat and Temperature Concepts”.*Research In Science & Technological Education*, 25(1), 115-133.
- Dale, N. B., & Lewis, J. (2007). *Computer science illuminated* (3rd ed.). Jones & Bartlett Learning.
- Gagne, R. M., Briggs, L. J., & Wager, W.W. (1992). *Principles of instructional design*, 4.baskı. New York, NY: Harcourt Brace Jovanovich College Publishers.
- Koile, K., & Singer, D. (2006). Improving learning in CS1 via tablet-PC-based in-class assessment. In *Proceedings of the second international workshop on computing education research* (pp. 119–126). ACM.
- Merrick, K. E. (Nov. 2010). An empirical evaluation of puzzle-based learning as an interest approach for teaching introductory computer science. *IEEE Transactions on Education*, 53(4), 677–680.
- Özgüven, İ. E. (1998). *Psikolojik Testler*. Ankara: PDREM Yayınları.
- Parhami, B. (Aug. 2009). Motivating computer engineering freshmen through mathematical and logical puzzles. *IEEE Transactions on Education*, 52(3), 360–364.
- Verginis, I., Gogoulou, A., Gouli, [5]E., Boubouka, M., & Grigoriadou, M. (Feb. 2011). Enhancing learning in introductory computer science courses through SCALE: an empirical study. *IEEE Transactions on Education*, 54(1), 1–13
- Wolcott, H. F. (1994). Description, analysis, and interpretation in qualitative inquiry. *Transforming qualitative data*, 9-54.
- Wu, H. T., Hsu, P. C., Lee, C. Y., Wang, H. J., & Sun, C. K. (2014). The impact of supplementary hands-on practice on learning in introductory computer science course for freshmen. *Computers & Education*, 70, 1-8.
- Yin, R. K. (1984). *Case Study Research: Design and Methods*. Newbury Park, CA.:Sage.

ÖĞRETMENLİK UYGULAMASINDA GÖREV ALAN UYGULAMA ÖĞRETMENLERİNİN FEN VE TEKNOLOJİ ÖĞRETMEN ADAYLARININ YAPISALCI ÖĞRENME KURAMINA KARŞI TUTUMLARI ÜZERİNE ETKİSİ

Yrd. Doç. Dr. Sinan ÇINAR
Recep Tayyip Erdoğan Üniversitesi Eğitim Fakültesi
sinan.cinar@erdogan.edu.tr

Bu çalışmanın amacı ilköğretim fen ve teknoloji öğretmen adaylarının yapısalci öğrenme kuramına karşı tutum geliştirmelerinde uygulama öğretmenlerinin etkisi olup olmadığını tespit etmektir. Araştırma yöntemi olarak betimsel araştırma yöntemlerinden biri olan özel durum araştırma yöntemi kullanılmıştır. Çalışma 20011–20013 yılları arasında RTE Üniversitesi Eğitim Fakültesi ile Rize Milli Eğitim Müdürlüğüne bağlı ilköğretim okulları işbirliğinde yürütülen öğretmenlik uygulaması dersini kapsamaktadır. Çalışmada veri toplama aracı olarak mülakat ve doküman analizi tekniği kullanılmıştır. İki eğitim öğretim yılında fen ve teknoloji öğretmenliği bölümünden öğrenim gören adaylardan rastgele seçilen 40 öğretmen adayı ile mülakat yapılmıştır. Ayrıca bu yıllar arasında ilköğretim fen ve teknoloji öğretmen adaylarının staj dosyaları incelenmiştir. Öğretmen adaylarının staj dosyalarında uygulama öğretmenleri hakkındaki düşüncelerinin yer aldığı en az iki sayfalık doküman bulunmaktadır; öğretmen adaylarının öğretmenlik uygulaması staj dosyalarında rastgele 40 dosya seçilerek toplam 80 dosya ve yaklaşık olarak 200 doküman analiz edilmiştir. Elde edilen verilerden; fen ve teknoloji öğretmen adaylarının büyük çoğunluğunun (% 70) yapısalcılığa karşı olumsuz tutuma sahip oldukları, geri kalanların %25'inin olumlu tutuma sahipken %5'inin hem olumlu tutum hem de olumsuz tutum taşıdıkları tespit edilmiştir. Bu tutumun sergilemesinde uygulama öğretmenlerinin sınıflarda yapısalcılığı uygulamaz olduğu, kaynak gerektirdiği, sınıfların kalabalık olduğu, fakülte ve okulun farklı iki öğretim ortamı olduğu, önemli olan öğrenci başarısı gibi düşüncelerinin etkili olduğu tespit edilmiştir. Sonuç olarak öğretmenlik uygulama dersleri tekrar yeniden yapılmalı ve özellikle uygulama öğretmenleri 2 saatlik seminerle değil uzun bir hizmet-içi eğitim sonucunda bu kapsama dahil edilerek adaylar için verimli bir uygulama haline getirilebilir.

Anahtar sözcükler: fakülte-okul işbirliği, yapısalci öğrenme kuramı, öğretmen adayları

PRACTICE TEACHERS EFFECT ON ATTITUDE OF PROSPECTIVE ELEMANTARY SCIENCE AND TECHONOLOGY TEACHERS DEVELOPING ABOUT CONSTRUCTIVE LEARNING APPROACH

Yrd. Doç. Dr. Sinan ÇINAR
Recep Tayyip Erdoğan Üniversitesi Eğitim Fakültesi
sinan.cinar@erdogan.edu.tr

Aim of this is to determine whether practiceteachers effect on prospective elementary science and technology teachers attitude which development about constructivist learning approach. Subjects for this study were randomly selected 40 prospective primary school science and technology teachers learning in Recep Tayyip University Primary Science and Technology Teachers Department in 20011-2013 academic year. A document analysis method was used to gather data Findings indicated that much of prospective teachers (%70) have negative attitude on constructivist education and rest of their has negative attitude. Practiceteachers possess important effective prospective teachers displaying negative attitude about constructivist approach.

Key Words: Teaching Practice lesson, Constructivist Learning Approach, Prospective Teachers.

Some Results on Cyclic Codes Over $F_2 + uF_2 + vF_2 + uvF_2$

Evren Salkım

Department of Mathematics, Sakarya University, TR54187 Sakarya, Turkey

evren.salkim@ogr.sakarya.edu.tr

ABSTRACT: In this paper, we investigate the structure and properties of cyclic codes over the ring $F_2 + uF_2 + vF_2 + uvF_2$ where $u^2 = u, v^2 = v$ and $uv = vu$. We first study the relationship between cyclic codes over $F_2 + uF_2 + vF_2 + uvF_2$ and binary cyclic codes. We prove that cyclic codes over the ring are principally generated, and give the generator polynomial of cyclic codes over this ring.

Keywords: Cyclic code, gray map, generator matrix, finite rings.

I. INTRODUCTION

Codes over finite rings have been studied in the early 1970's [4]. Cyclic codes are an important class of codes from both a theoretical and practical viewpoint. Traditionally, cyclic codes had been studied over finite fields.

However, it was discovered that some good nonlinear codes over Z_2 can be viewed as binary images under a Gray map of linear cyclic codes over Z_4 and this had motivated the study of cyclic codes over finite rings

in [10]. Linear codes, cyclic codes and cyclic self-dual codes over $F_2 + uF_2 + vF_2 + uvF_2$ where $u^2 = v^2 = 0$ and $uv = vu$ were studied in [6-7-8]. In [13], they described the structure of cyclic codes and cyclic self-dual codes over $F_2 + vF_2$ where $v^2 = v$. The relation between cyclic codes over $F_2 + vF_2$ and binary cyclic codes was studied.

They proved that every cyclic code over $F_2 + vF_2$ was principally generated and obtained the generator polynomial of cyclic codes over the ring. Not much work has been done on the structure of

cyclic codes over $F_2 + uF_2 + vF_2 + uvF_2$. In this correspondence, we investigate the structure of cyclic codes over the ring $F_2 + uF_2 + vF_2 + uvF_2$ where $u^2 = u, v^2 = v$ and $uv = vu$. We prove that cyclic codes over the ring are principally generated, and give the generator polynomial of cyclic codes over this ring.

In Section II, we recall some backgrounds and notations about this ring. We discuss the generator matrices and their Gray images of linear codes over $F_2 + uF_2 + vF_2 + uvF_2$ in Section III. Section IV describes the structure of cyclic codes and cyclic self-dual codes over $F_2 + uF_2 + vF_2 + uvF_2$, and the relationship between cyclic codes over $F_2 + uF_2 + vF_2 + uvF_2$ and binary cyclic codes is studied. For the rest of this work, R_2 denote $F_2 + uF_2 + vF_2 + uvF_2$ and R_1 denote the ring $F_2 + vF_2$.

II. PRELIMINARIES

Let R_2 be the commutative ring $F_2 + uF_2 + vF_2 + uvF_2$ where $u^2 = u, v^2 = v$ and $uv = vu$. Unlike other rings of order 16, every element in this ring is idempotent. It is easy to verify that R_2 is a semi-local ring with four minimal ideals given by $I_1 = \langle uv \rangle, I_2 = \langle v + uv \rangle, I_3 = \langle u + uv \rangle, I_4 = \langle 1 + u + v + uv \rangle$. Any element of R_2 can be expressed as $c' = a + ub + vc + uv d$, where $a, b, c, d \in F_2$. We take R_2 to be a natural extension of the ring R_1 . Recall that the elements of R_1 are $0, 1, v, 1+v$ which have Lee weights $0, 2, 1, 1$ respectively. Gray map from R_1 to F_2^2 is given by $\phi(c') = (a, a+b)$, thus ϕ is a bijection in [13]. This leads to Gray map from R_2 to F_2^4 is given by $\phi(c') = (a, a+b, a+c, a+b+c+d)$. The Lee weight ϕ is a distance preserving isometry from (R_2^n, d_L) to (F_2^{4n}, d_H) , where d_L and d_H denote the Lee and Hamming distance in R_2^n and F_2^{4n} respectively. This means if C is a linear code over R_2 with parameters $(n, 2^k, d)$, then $\phi(C)$ is a binary linear code of parameters $[4n, k, d]$. Let $x = (x_1, x_2, \dots, x_n)$ and $y = (y_1, y_2, \dots, y_n)$ be two elements of R_2^n , the Euclidean inner product of x and y in R_2^n is defined by $x \cdot y = x_1 y_1 + x_2 y_2 + \dots + x_n y_n$. The dual code of C is defined as $C^\perp = \{x \in R_2^n, x \cdot y = 0, \forall y \in C\}$. A code C is self-orthogonal if $C \subseteq C^\perp$ and self-

dual if $C = C^\perp$. For any $[n, k]$ code, the generator matrix of C is a $k \times n$ matrix G whose rows generate C and the parity check matrix of C is an $(n-k) \times n$ matrix H whose rows generate C^\perp . Two codes are equivalent if one can be obtained from the other by permuting the coordinates. A cyclic code C of length n over R_2 is a linear code with property that if $c = (c_0, c_1, \dots, c_{n-1}) \in C$ then $\sigma(c) = (c_{n-1}, c_0, \dots, c_{n-2}) \in C$.

III. LINEAR CODES OVER $F_2 + uF_2 + vF_2 + uvF_2$

If A, B, C and D are codes, we denote that $A \otimes B \otimes C \otimes D = \{(a, b, c, d), a \in A, b \in B, c \in C, d \in D\}$ and $A \oplus B \oplus C \oplus D = \{a + b + c + d, a \in A, b \in B, c \in C, d \in D\}$. Let C be a linear code of length n over R_2 . Define $C_1 = \{a \in F_2^n | a + ub + vc + uvd \in C, \text{ for some } b, c, d \in F_2^n\}$

$$C_2 = \{a + b \in F_2^n | a + ub + vc + uvd \in C, \text{ for some } c, d \in F_2^n\}.$$

$$C_3 = \{a + c \in F_2^n | a + ub + vc + uvd \in C, \text{ for some } b, d \in F_2^n\}$$

$$C_4 = \{a + b + c + d \in F_2^n | a + ub + vc + uvd \in C\}$$

Obviously, C_1, C_2, C_3, C_4 are binary linear codes. We have the following:

Theorem 3.1: Let C be a linear code of length n over R_2 . Then $\phi(C) = C_1 \otimes C_2 \otimes C_3 \otimes C_4$, and $|C| = |C_1| \cdot |C_2| \cdot |C_3| \cdot |C_4|$.

Proof: For any $(a_1, a_2, \dots, a_n, b_1, b_2, \dots, b_n, c_1, c_2, \dots, c_n, d_1, d_2, \dots, d_n) \in \phi(C)$, Let

$$q_i = a_i + u(a_i + b_i) + v(a_i + c_i) + uv(a_i + b_i + c_i + d_i), i = 1, 2, \dots, n. \text{ Since is a bijection,}$$

$$q = (q_1, q_2, \dots, q_n) \in C. \text{ By the definitions of } C_1, C_2, C_3 \text{ and } C_4, \text{ we obtain that any } (a_1, a_2, \dots, a_n) \in C_1,$$

$$(b_1, b_2, \dots, b_n) \in C_2, (c_1, c_2, \dots, c_n) \in C_3, (d_1, d_2, \dots, d_n) \in C_4, \text{ therefore,}$$

$$(a_1, a_2, \dots, a_n, b_1, b_2, \dots, b_n, c_1, c_2, \dots, c_n, d_1, d_2, \dots, d_n) \in C_1 \otimes C_2 \otimes C_3 \otimes C_4. \text{ This implies that}$$

$$\phi(C) \subseteq C_1 \otimes C_2 \otimes C_3 \otimes C_4. \text{ On the other hand, for any}$$

$$(a_1, a_2, \dots, a_n, b_1, b_2, \dots, b_n, c_1, c_2, \dots, c_n, d_1, d_2, \dots, d_n) \in C_1 \otimes C_2 \otimes C_3 \otimes C_4, \text{ where}$$

$$(a_1, a_2, \dots, a_n) \in C_1, (b_1, b_2, \dots, b_n) \in C_2, (c_1, c_2, \dots, c_n) \in C_3, (d_1, d_2, \dots, d_n) \in C_4, \text{ there are}$$

$$x = (x_1, x_2, \dots, x_n), y = (y_1, y_2, \dots, y_n), z = (z_1, z_2, \dots, z_n), w = (w_1, w_2, \dots, w_n) \in C, \text{ such that}$$

$$x_i = a_i + uv m_i, y_i = b_i + (v + uv) n_i, z_i = c_i + (u + uv) k_i, w_i = d_i + (1 + u + v + uv) l_i, \text{ where}$$

$$m_i, n_i, k_i, l_i \in F_2 \text{ and } 1 \leq i \leq n. \text{ Since } C \text{ is linear, we have,}$$

$$q = (1 + u + v + uv)x + (u + uv)y + (v + uv)z + (uv)w = a + u(a + b) + v(a + c) + uv(a + b + c + d) \in C$$

which gives $C_1 \otimes C_2 \otimes C_3 \otimes C_4 \subseteq \phi(C)$. Therefore $\phi(C) = C_1 \otimes C_2 \otimes C_3 \otimes C_4$. The second result is easy to verify.

Corollary 3.2: If G_1, G_2, G_3 and G_4 are the generator matrices of binary linear codes C_1, C_2, C_3, C_4 , respectively then the generator matrix C is

$$\begin{pmatrix} (1+u+v+uv)G_1 \\ (u+uv)G_2 \\ (v+uv)G_3 \\ (uv)G_4 \end{pmatrix}$$

Moreover, if $G_1 = G_2 = G_3 = G_4$ then $G = G_1$.

Corollary 3.3: If $\phi(C) = C_1 \otimes C_2 \otimes C_3 \otimes C_4$ then C can be uniquely expressed as

$$C = (1 + u + v + uv)C_1 \oplus (u + uv)C_2 \oplus (v + uv)C_3 \oplus (uv)C_4$$

Proposition 3.4: Let d_H and d_L denote the minimum Hamming and Lee weights of a linear code over R_2 , respectively. Then

$$d_H = d_L = \min \{d(C_1), d(C_2), d(C_3), d(C_4)\}, \text{ where } d(C_i) \text{ denotes the minimum weight of a binary code } C_i.$$

Proof: Because ϕ is an weight-preserving map, then, $d_L(C) = d_H(\phi(C)) = d_H(C_1 \otimes C_2 \otimes C_3 \otimes C_4)$, and $d_H = d_L$ is obvious.

With the similar proof of Proposition 1.1 in [14], we have the following: A nonzero linear code C over R_2 has a generator matrix which after a suitable permutation of the coordinates can be written in the form

$$G = \begin{pmatrix} I_{k_1} & A_1 & A_2 & A_3 & A_4 & B_1 + uB_2 + vB_3 + uvB_4 \\ 0 & (uv)I_{k_2} & 0 & 0 & 0 & (uv)C_1 \\ 0 & 0 & (v + uv)I_{k_3} & 0 & 0 & (v + uv)D_1 \\ 0 & 0 & 0 & (u + uv)I_{k_4} & 0 & (u + uv)E_1 \\ 0 & 0 & 0 & 0 & (1 + u + v + uv)I_{k_5} & (1 + u + v + uv)F_1 \end{pmatrix}$$

where I_{k_i} is a $k_i \times k_i$ identity matrix, $A_1, A_2, A_3, A_4, B_1, B_2, B_3, B_4, C_1, D_1, E_1, F_1$ are matrices over F_2 .

$|C| = 16^{k_1} 2^{k_2} 2^{k_3} 2^{k_4} 2^{k_5}$. Hence, the generator matrix of $\phi(C) = C_1 \otimes C_2 \otimes C_3 \otimes C_4$ is

$$\begin{pmatrix} G_1 & 0 & 0 & 0 \\ 0 & G_2 & 0 & 0 \\ 0 & 0 & G_3 & 0 \\ 0 & 0 & 0 & G_4 \end{pmatrix}$$

where

$$G_1 = \begin{pmatrix} I_{k_1} & A_1 & A_2 & A_3 & A_4 & B_1 \\ 0 & 0 & 0 & 0 & I_{k_5} & F_1 \end{pmatrix}$$

$$G_2 = \begin{pmatrix} I_{k_1} & A_1 & A_2 & A_3 & A_4 & B_1 + B_2 \\ 0 & 0 & 0 & I_{k_4} & 0 & E_1 \end{pmatrix}$$

$$G_3 = \begin{pmatrix} I_{k_1} & A_1 & A_2 & A_3 & A_4 & B_1 + B_3 \\ 0 & 0 & I_{k_3} & 0 & 0 & D_1 \end{pmatrix}$$

$$G_4 = \begin{pmatrix} I_{k_1} & A_1 & A_2 & A_3 & A_4 & B_1 + B_2 + B_3 + B_4 \\ 0 & I_{k_2} & 0 & 0 & 0 & C_1 \end{pmatrix}$$

are the generator matrices of binary linear codes C_1, C_2, C_3, C_4 , respectively. Moreover

$$|C_1| = 2^{k_1} 2^{k_5}, |C_2| = 2^{k_1} 2^{k_4}, |C_3| = 2^{k_1} 2^{k_3} \text{ and } |C_4| = 2^{k_1} 2^{k_2}.$$

Lemma 3.5: Let C^\perp be the dual code of C . Then $\phi(C^\perp) = \phi(C)^\perp$. Moreover, if C is a self-dual code, so is $\phi(C)$.

Theorem 3.6: Let C be a linear code of length n over R_2 and $\phi(C) = C_1 \otimes C_2 \otimes C_3 \otimes C_4$, so that

$C = (1 + u + v + uv)C_1 \oplus (u + uv)C_2 \oplus (v + uv)C_3 \oplus (uv)C_4$. Then, $\phi(C^\perp) = C_1^\perp \otimes C_2^\perp \otimes C_3^\perp \otimes C_4^\perp$.
Moreover, we have $C^\perp = (1 + u + v + uv)C_1^\perp \oplus (u + uv)C_2^\perp \oplus (v + uv)C_3^\perp \oplus (uv)C_4^\perp$.

Proof: By Lemma 3.5, $\phi(C^\perp) = (C_1 \otimes C_2 \otimes C_3 \otimes C_4)^\perp$. Hence, we

only need to prove that $C_1^\perp \otimes C_2^\perp \otimes C_3^\perp \otimes C_4^\perp = (C_1 \otimes C_2 \otimes C_3 \otimes C_4)^\perp$. Obviously,

$C_1^\perp \otimes C_2^\perp \otimes C_3^\perp \otimes C_4^\perp \subseteq (C_1 \otimes C_2 \otimes C_3 \otimes C_4)^\perp$. On the other hand, suppose that C_1, C_2, C_3, C_4 are $[n, k_1], [n, k_2], [n, k_3], [n, k_4]$ binary linear codes, respectively, then

$C_1^\perp, C_2^\perp, C_3^\perp, C_4^\perp, C_1 \otimes C_2 \otimes C_3 \otimes C_4$ are

$[n, n - k_1], [n, n - k_2], [n, n - k_3], [n, n - k_4], [4n, k_1 + k_2 + k_3 + k_4]$ binary linear codes, respectively, thus,

$C_1^\perp \otimes C_2^\perp \otimes C_3^\perp \otimes C_4^\perp = |C_1^\perp| \otimes |C_2^\perp| \otimes |C_3^\perp| \otimes |C_4^\perp| = |(C_1 \otimes C_2 \otimes C_3 \otimes C_4)^\perp| = 2^{4n - k_1 - k_2 - k_3 - k_4}$. Hence,

$C_1^\perp \otimes C_2^\perp \otimes C_3^\perp \otimes C_4^\perp = (C_1 \otimes C_2 \otimes C_3 \otimes C_4)^\perp$. In light of Corollary 3.3, we obtain the last statement

IV. CYCLIC CODES OVER $F_2 + uF_2 + vF_2 + uvF_2$

Theorem 4.1: If $C = (1 + u + v + uv)C_1 \oplus (u + uv)C_2 \oplus (v + uv)C_3 \oplus (uv)C_4$ is a linear code over R_2 ,

then C is a cyclic code over R_2 if and only if C_1, C_2, C_3, C_4 are binary cyclic codes.

Proof: For any $q = (q_1, q_2, \dots, q_n) \in C$, where $q_i = a_i + ub_i + vc_i + uvd_i, i = 1, 2, \dots, n$, let

$(a_1, a_2, \dots, a_n), (b_1, b_2, \dots, b_n), (c_1, c_2, \dots, c_n), (d_1, d_2, \dots, d_n)$, then

$a \in C_1, a + b \in C_2, a + c \in C_3, a + b + c + d \in C_4$. If C_1, C_2, C_3, C_4 are binary cyclic codes, then

$\sigma(a) \in C_1, \sigma(a + b) \in C_2, \sigma(a + c) \in C_3, \sigma(a + b + c + d) \in C_4$. Hence

$\sigma(q) = (1 + u + v + uv)\sigma(a) + (u + uv)\sigma(a + b) + (v + uv)\sigma(a + c) + (uv)\sigma(a + b + c + d) \in C$

, which means that C is a cyclic code over R_2 . On the other hand, for any

$a = (a_1, a_2, \dots, a_n) \in C_1, b = (b_1, b_2, \dots, b_n) \in C_2, c = (c_1, c_2, \dots, c_n) \in C_3, d = (d_1, d_2, \dots, d_n) \in C_4$

, let $q_i = a_i + u(a_i + b_i) + v(a_i + c_i) + uv(a_i + b_i + c_i + d_i)$, then $q = (q_1, q_2, \dots, q_n) \in C$. If C is a cyclic code over R_2 , we have $\sigma(q) \in C$. It follows that

$\phi(\sigma(q)) = (\sigma(a), \sigma(b), \sigma(c), \sigma(d)) \in C_1 \otimes C_2 \otimes C_3 \otimes C_4$, thus $\sigma(a) \in C_1, \sigma(b) \in C_2, \sigma(c) \in C_3$, and $\sigma(d) \in C_4$. Therefore, C_1, C_2, C_3, C_4 are binary cyclic codes

Corollary 4.2: If C is a cyclic code over R_2 , then the dual code C^\perp of C is also cyclic.

Corollary 4.3: C is a cyclic self-dual code over R_2 if and only if C_1, C_2, C_3, C_4 are binary cyclic self-dual codes.

Theorem 4.4: If $C = (1 + u + v + uv)C_1 \oplus (u + uv)C_2 \oplus (v + uv)C_3 \oplus (uv)C_4$ is a cyclic code

of length n over R_2 , then $C = \langle (1+u+v+uv)g_1 \oplus (u+uv)g_2 \oplus (v+uv)g_3 \oplus (uv)g_4 \rangle$ and $|C| = 2^{4n - \deg(g_1(x)) - \deg(g_2(x)) - \deg(g_3(x)) - \deg(g_4(x))}$, where $g_1(x), g_2(x), g_3(x), g_4(x)$ are the generator polynomials of C_1, C_2, C_3, C_4 , respectively.

Proof: In light of $C_1 = \langle g_1(x) \rangle, C_2 = \langle g_2(x) \rangle, C_3 = \langle g_3(x) \rangle, C_4 = \langle g_4(x) \rangle$ and $C = (1+u+v+uv)C_1 \oplus (u+uv)C_2 \oplus (v+uv)C_3 \oplus (uv)C_4$, it follows that $C = \{q(x) = (1+u+v+uv)g_1(x)r_1(x) + (u+uv)g_2(x)r_2(x) + (v+uv)g_3(x)r_3(x) + (uv)g_4(x)r_4(x) \mid r_1(x), r_2(x), r_3(x), r_4(x) \in F_2[x]\}$, so $C \subseteq \langle (1+u+v+uv)g_1(x), (u+uv)g_2(x), (v+uv)g_3(x), (uv)g_4(x) \rangle \subseteq R_2[x]/x^n - 1$. For any $(1+u+v+uv)g_1(x)k_1(x) + (u+uv)g_2(x)k_2(x) + (v+uv)g_3(x)k_3(x) + (uv)g_4(x)k_4(x) \in \langle (1+u+v+uv)g_1(x), (u+uv)g_2(x), (v+uv)g_3(x), (uv)g_4(x) \rangle$, where $k_1(x), k_2(x), k_3(x), k_4(x) \in R_2[x]/x^n - 1$, there exist $r_1(x), r_2(x), r_3(x), r_4(x) \in F_2[x]$ such that, $(1+u+v+uv)k_1(x) = (1+u+v+uv)r_1(x), (u+uv)k_2(x) = (u+uv)r_2(x), (v+uv)k_3(x) = (v+uv)r_3(x), (uv)k_4(x) = (uv)r_4(x)$ so we have $\langle (1+u+v+uv)g_1(x), (u+uv)g_2(x), (v+uv)g_3(x), (uv)g_4(x) \rangle \subseteq C$. This gives $C = \langle (1+u+v+uv)g_1(x), (u+uv)g_2(x), (v+uv)g_3(x), (uv)g_4(x) \rangle$. Since $C = |C_1| \cdot |C_2| \cdot |C_3| \cdot |C_4|$, we have $|C| = 2^{4n - \deg(g_1(x)) - \deg(g_2(x)) - \deg(g_3(x)) - \deg(g_4(x))}$.

Theorem 4.5: For any cyclic code C of length n over R_2 , there is a unique polynomial $g(x)$ such that $C = \langle g(x) \rangle$, and $g(x) \mid x^n - 1$, where $g(x) = (1+u+v+uv)g_1 + (u+uv)g_2 + (v+uv)g_3 + (uv)g_4$. Moreover, If $g_1(x) = g_2(x) = g_3(x) = g_4(x)$ then $g(x) = g_1(x)$.

Proof: By Theorem 4.4, we may assume that $C = \langle (1+u+v+uv)g_1(x), (u+uv)g_2(x), (v+uv)g_3(x), (uv)g_4(x) \rangle$. Let $g(x) = (1+u+v+uv)g_1(x) + (u+uv)g_2(x) + (v+uv)g_3(x) + (uv)g_4(x)$, where $g_1(x), g_2(x), g_3(x), g_4(x)$ are generator polynomials of C_1, C_2, C_3, C_4 , respectively.

Clearly, $\langle g(x) \rangle \subseteq C$. On the other hand, $(1+u+v+uv)g_1(x) = (1+u+v+uv)g(x), (u+uv)g_2(x) = (u+uv)g(x), (v+uv)g_3(x) = (v+uv)g(x)$ and $(uv)g_4(x) = (uv)g(x)$. This gives $C \subseteq \langle g(x) \rangle$, hence $C = \langle g(x) \rangle$. Since $g_1(x) \mid x^n - 1, g_2(x) \mid x^n - 1, g_3(x) \mid x^n - 1$ and $g_4(x) \mid x^n - 1$, there exist $r_1(x), r_2(x), r_3(x), r_4(x) \in R_2[x]/x^n - 1$ such that $x^n - 1 = g_1(x)r_1(x) = g_2(x)r_2(x) = g_3(x)r_3(x) = g_4(x)r_4(x)$, it follows that $x^n - 1 = g(x)[(1+u+v+uv)r_1(x) + (u+uv)r_2(x) + (v+uv)r_3(x) + (uv)r_4(x)]$, hence $g(x) \mid x^n - 1$.

Corollary 4.6: Every ideal of $R_2[x]/x^n - 1$ is principal.

The next lemma 1 from [11] describes a necessary and sufficient condition for self-orthogonality of cyclic codes.

Lemma 4.7: A binary linear cyclic code C with generator polynomial $g(x)$ contains its dual code iff $x^n - 1 \equiv 0 \pmod{g(x)g^*(x)}$

Where $g^*(x) = x^{n-k}g(1/x)$ ie. $g^*(x)$ is the reciprocal polynomial of $g(x)$.

Now, we give a sufficient and necessary condition for cyclic code over R_2 that contains its dual.

Theorem 4.8: Suppose $C = \langle g(x) \rangle$ is a cyclic code of arbitrary length n over R_2 , where

$g(x) = (1+u+v+uv)g_1 + (u+uv)g_2 + (v+uv)g_3 + (uv)g_4$. Then $C^\perp \subseteq C$ if and only if

$$x^n - 1 \equiv 0 \pmod{(g_1(x)g_1^*(x))}, \quad x^n - 1 \equiv 0 \pmod{(g_2(x)g_2^*(x))}$$

$$x^n - 1 \equiv 0 \pmod{(g_3(x)g_3^*(x))}, \quad x^n - 1 \equiv 0 \pmod{(g_4(x)g_4^*(x))}$$

Proof: Let $C = \langle g(x) \rangle = (1+u+v+uv)C_1 \oplus (u+uv)C_2 \oplus (v+uv)C_3 \oplus (uv)C_4$ be a cyclic code of length n over R_2 , then $C = \langle (1+u+v+uv)g_1(x), (u+uv)g_2(x), (v+uv)g_3(x), (uv)g_4(x) \rangle$,

$C_1 = \langle g_1(x) \rangle, C_2 = \langle g_2(x) \rangle, C_3 = \langle g_3(x) \rangle$ and $C_4 = \langle g_4(x) \rangle$. If

$$x^n - 1 \equiv 0 \pmod{(g_1(x)g_1^*(x))}, x^n - 1 \equiv 0 \pmod{(g_2(x)g_2^*(x))}$$

$$x^n - 1 \equiv 0 \pmod{(g_3(x)g_3^*(x))}, x^n - 1 \equiv 0 \pmod{(g_4(x)g_4^*(x))}$$

Then $C_1^\perp \subseteq C_1, C_2^\perp \subseteq C_2, C_3^\perp \subseteq C_3, C_4^\perp \subseteq C_4$.

Hence

$$\langle (1+u+v+uv)h_1^*(x), (u+uv)h_2^*(x), (v+uv)h_3^*(x), (uv)h_4^*(x) \rangle \subseteq \langle (1+u+v+uv)g_1(x), (u+uv)g_2(x), (v+uv)g_3(x), (uv)g_4(x) \rangle$$

Thus, $C^\perp \subseteq C$.

Conversely, if $C^\perp \subseteq C$, then,

$$(1+u+v+uv)C_1^\perp \oplus (u+uv)C_2^\perp \oplus (v+uv)C_3^\perp \oplus (uv)C_4^\perp \subseteq (1+u+v+uv)C_1 \oplus (u+uv)C_2 \oplus (v+uv)C_3 \oplus (uv)C_4$$

Thus, $C_1^\perp \subseteq C_1, C_2^\perp \subseteq C_2, C_3^\perp \subseteq C_3, C_4^\perp \subseteq C_4$. Therefore,

$$x^n - 1 \equiv 0 \pmod{(g_1(x)g_1^*(x))}, x^n - 1 \equiv 0 \pmod{(g_2(x)g_2^*(x))}$$

$$x^n - 1 \equiv 0 \pmod{(g_3(x)g_3^*(x))}, x^n - 1 \equiv 0 \pmod{(g_4(x)g_4^*(x))}$$

This completes the proof.

Corollary 4.9: Suppose $C = (1+u+v+uv)C_1 \oplus (u+uv)C_2 \oplus (v+uv)C_3 \oplus (uv)C_4$ is a cyclic code of arbitrary length n over R_2 . Then $C^\perp \subseteq C$ if and only if $C_1^\perp \subseteq C_1, C_2^\perp \subseteq C_2, C_3^\perp \subseteq C_3, C_4^\perp \subseteq C_4$.

V. CONCLUSION

In this paper, we study cyclic codes of an arbitrary length n over $F_2 + uF_2 + vF_2 + uvF_2$, and prove that cyclic codes are principally generated. Another direction for research in this topic is of course the generalizations $F_q + uF_q + vF_q + uvF_q$ of $F_2 + uF_2 + vF_2 + uvF_2$, where q is a prime power.

REFERENCES

- [1] T. Abualrub and I. Siap. (2007), "Cyclic codes over the rings $Z_2 + uZ_2$ and $Z_2 + uZ_2 + u^2Z_2$ ", *Des. Codes Cryptogr.*, vol. 42, 273–287
- [2] A. Bonnetcaze and P. Udaya. (1999), "Cyclic codes and self-dual codes over $F_2 + uF_2$ ", *IEEE Trans. Inf. Theory*, vol. 45, 1250–1255
- [3] S. T. Dougherty, P. Gaborit, M. Harada, and P. Solé, Self-Dual Codes Over $F_2 + vF_2$, preprint.
- [4] I.F. Blake. (1972), Codes over certain rings, *Inform. Contr.* 20, 396-404
- [5] V. Pless, P. Solé, and Z. Q. Qian. (1999), "Cyclic self-dual Z_4 -codes," *Finite Fields and Their Appl.*, 3, 48-69
- [6] B.Yildiz, S.Karadeniz. (2010), Linear codes over $F_2 + uF_2 + vF_2 + uvF_2$, *Des. Codes Crypt.* 54, 61–81.
- [7] B.Yildiz, S.Karadeniz. (2011), Cyclic codes over $F_2 + uF_2 + vF_2 + uvF_2$, *Des. Codes Crypt.* 58, 221–234.
- [8] B.Yildiz, S.Karadeniz. (2010), Self-dual codes over $F_2 + uF_2 + vF_2 + uvF_2$, *J.Frank.Inst.* 347, 1888–1894.

- [9] X.Kai,S.Zhu. (2011) ,Quaternary construction of quantum codes from cyclic codes over $F_4 + uF_4$, *International Journal of Quantum Inform*, 2 , 689-700
- [10] A. Hammons, P.V.Kumar, A.R.Calderbank, N.J.A.Sloane, P.Sole. (1994), The Z_4 -linearity of Kerdock,Preparata,Goethals and Related codes, *IEEE Trans Inform. Theory*, 40, 301-319
- [11] A. R. Calderbank, E. M. Rains, P. M. Shor, N. J. A. Sloane. (1998), Quantum error correction via codes over GF(4), *IEEE Trans. Inf. Theory*, 44, 1369-1387
- [12] H.Sboui,A.Bouallegue and P.Sole. (2011), Cyclic codes and self-dual codes over $M(F_2)$ and $M(F_2[i])$, *IEEE Trans. Inf. Theory* .249-252
- [13] S. Zhu, Y. Wang, M. Shi .(2009), Cyclic code over $F_2 + vF_2$, *IEEE Trans. Inf. Theory* .1719-1722
- [14] Z. X. Wan. (1997)., Quaternary Codes. Singapore: *World Scientific*
- [15] J.Qian .(2013), Quantum Codes from Cyclic Codes over $F_2 + vF_2$, *Journal of Information & Computational Science* 10:6 . 1715-1722
- [16] J.Qian, W.Ma . (2008) ,Self-dual codes over finite chain ring, *IEEE Trans. Inf. Theory* 250-252
- [17] A. Ketkar et al . (2006), Nonbinary quantum stabiliter codes over finite fields, *IEEE Trans. Inf. Theory*, 52 ,4892-4914

IŞIK KİRLİLİĞİNE İLİŞKİN BİLGİSAYAR DESTEKLİ KAVRAM KARİKATÜRLERİNİN GELİŞTİRİLMESİ

DEVELOPING COMPUTER - AIDED CONCEPT CARTOONS ON LIGHT POLLUTION

Güliz AYDIN

Muğla Sıtkı Koçman Üniversitesi Eğitim Fakültesi
gulizaydin@gmail.com

Cengiz ÖZYÜREK

Ordu Üniversitesi Eğitim Fakültesi
cengizozyurek@outlook.com

ÖZET: Çalışmada, 7. sınıf “Canlılar ve Hayat” öğrenme alanındaki “İnsan ve Çevre” ünitesinde yer alan “Çevre Sorunları ve Etkileri” konusu içerisinde Işık Kirliliği ele alınmış ve Fen ve Teknoloji Öğretim Programındaki konuya ilişkin kazanımları gerçekleştirmeye yönelik bilgisayar destekli kavram karikatürleri hazırlanmıştır. Fen ders kitaplarında, “Çevre Sorunları ve Etkileri” konusu içerisinde pek çok çevre sorunundan söz edilmekle birlikte, Işık Kirliliğine değinilmemektedir. Oysa ki Işık Kirliliği, ekolojik ve ekonomik açıdan olumsuz sonuçlar doğuran önemli bir çevre sorunudur. Öğrencilere ışık kirliliğine ilişkin farkındalık kazandırmayı amaçlayan bu çalışmada, ışık kirliliğinin nedenleri ve etkilerine yönelik senaryolar ve bilgisayar destekli kavram karikatürleri geliştirilmiştir. Bu etkinlikler, öğrencilerin konuya ilişkin zihinsel yapılandırmalarını ve kavram yanılgılarını ortaya çıkaracak niteliktedir. Günümüzün önemli çevre sorunlarından olan Işık Kirliliğine ilişkin farkındalık yaratmayı amaçlayan bu çalışmanın, Fen öğretmenlerinin de benzer etkinlikler geliştirmelerini ve derslerinde uygulamalarını destekleyeceği düşünülmektedir.

Anahtar sözcükler: fen eğitimi, ışık kirliliği, kavram karikatürleri

ABSTRACT: This study focuses on Light Pollution within the subject of “Environmental Problems and Their Effects” in the “Human and Environment” unit in the learning field of “Living Things and Life” for the 7th grades. Computer – aided Concept Cartoons were prepared to realize the acquisitions regarding the Science and Technology Curriculum. Despite mentioning various environmental issues within the subject, Light Pollution, another serious issue, that has negative effects on ecology and economy, is somehow ignored in coursebooks. In this study, that aims at raising awareness about Light Pollution, scenarios and computer-aided concept cartoons were designed to make the reasons and effects of light pollution clearer for the students. These activities are meant to reveal students’ mental constructions and misconceptions regarding the subject. This study aiming at raising awareness on light pollution, one of the serious environmental issues in the modern world, is expected to inspire science teachers to develop similiar activities for their classroom practices as well.

Key words: science education, light pollution, concept cartoons

CONCEPTUALIZATION OF PEDAGOGICAL CONTENT KNOWLEDGE (PCK) FOR TEACHING MATHEMATICS IN UNIVERSITY LEVEL

Azimehsadat Khakbaz
azimehkhakbaz@ymail.com

The aim of this study is conceptualization of pedagogical content knowledge (PCK) in the field of teaching mathematics in university level. This is a qualitative research which has done in mathematics discipline in Iranian higher education system. The data of this research were gathered through semi structured interviews with some PhD mathematics students and professors. They were analysed through coding and making themes. Data analysis showed that we could explain concept of PCK in a model with 4 main elements and 3 themes which influenced on that.

STATEMENT OF PROBLEM

Teaching and teacher's knowledge have always been a controversial field of study in education. Pedagogical content knowledge(PCK) is a familiar concept for researchers which first has introduced by Shulman(1985) as a "missing paradigm" in this field of study. Shulman(1987) described PCK as a special amalgam of content and pedagogy that is uniquely the province of teachers, their own special form of professional understanding. Although, PCK is an interesting concept which has absorbed many eyes, its nature is complicated. Besides, many research have been done about PCK in school level mathematics and specially school mathematics teachers education, but little has been done in mathematics education in university levels. While we know school mathematics teachers themselves have learned mathematics in universities. Moreover, not only mathematics students in university level, but also many students in other disciplines are learning mathematics and all these persons would be parents, teachers and members of society who will influence on mathematics education for future generation. Therefore, mathematics education in higher education level would effect on culture of mathematics education in university. Thus, the problem in this study is: what does PCK for teaching mathematics in university level mean?

THEORETICAL FRAMEWORK

The term of PCK is inherit Dewey's(1916-1964) that teachers must learn "psychologize" their subject matter for teaching to rethink disciplinary concepts and topics to make them more accessible to students(Counts, 1999).

After introduction of PCK many researchers tried to work on that concepts. One of the most influential researchers was Grossman (1988) who introduced two overarching categories: General and Specific PCK. These categories were later modified by Fernandez-Balboa & Stiehl (1995) to generic and specific. Specific PCK is particular to instruction of a specific subject or content area; and Generic PCK is common to instruction all content areas or subjects. Generic PCK refers to the fact that every discipline in higher education could have a concept of PCK. It means mathematics as a discipline has its PCK and surely this Generic PCK consist of Specific PCK, emerged from different subjects and content area. Grossman (1990) also described four categories embodied in PCK:

- Knowledge about the purposes for teaching a given subject matter (subject matter issue);
- Knowledge about the students' understandings about the content (students issue);
- Knowledge about the order in which subject matter should be presented (curricular issue);
- Knowledge about the instructional strategies useful for teaching content (pedagogical issue).

LITERATURE REVIEW

One of the initial studies about PCK in higher education has been done by Fernandez Balboa & Stiehl(1995). The aim of their research was to study the generic nature of PCK in higher education. To this aim they studied incorporated purposeful sampling of 10 professors from five different colleges (i.e., Arts and Sciences, Business, Education, Health and Human Sciences, and Visual and Performing Arts) at a university in the U.S.A. Data were obtained from personal phenomenological interviews. They analysed the data utilizing

the method of constant comparison looking for themes that linked the reflections of the participants. The results of this study showed that although initially their reference framework for analysing generic PCK was based on the four components outlined by Grossman(1990), a few important differences with regards to these components emerged from their analysis. These components include knowledge about: the subject matter, the students, numerous instructional strategies, the teaching context, and one's teaching purposes.

Counts(1999) did a research with two purposes: to contribute to a broader conceptualization and understanding of the development of general PCK in college level teaching by generalizing Shulman's(1987) and Grossman's(1988) model of PCK to college professors and to describe how a professor's PCK was constructed. He applied a case study research on a physics professors and gathered data through semi structured participant interviews and supportive data sources. Analysis of data was by analytical induction. Results showed five major themes emerged that reflected the professor's PCK: knowledge of the purpose of teaching, knowledge of students as learners, knowledge of human communications, knowledge of curriculum and course design and knowledge of positive learning environment. Therefore these findings disclosed that the PCK conceptualization of this study was in a large congruent with Shulman and Grossman's models.

Major and Palmer(2001) described several significant aspects of faculty PCK drawing on qualitative methods at a private university in the southern United States. They found out student learning is the heart of PCK. The focus of faculty PCK is that they must consider their students, how students will learn, and what difficulties they might have in learning. To help their students learn, then, faculty members need several kinds of knowledge about student learning. They must understand who their learners are, being responsive to differences that may arise from culture, family experiences, and learning styles and processes. Faculty members must figure out what students know and believe about a topic. They must also consider how learners are likely to engage and process new ideas. They need to think about how students learn different kinds of material for different purposes. And they must decide which kinds of learning are important for different contexts. Faculty members need to be able to identify the strengths and weaknesses of different learners and develop knowledge to work with students who have specific learning disabilities or needs.

METHODOLOGY

This research is a qualitative research. Data gathered mainly from two universities in Iran. These universities were selected among comprehensive universities. They were both prominent universities in field of mathematics and both were somehow engaged in mathematics education knowledge. One of them was the pioneer of development of mathematics education as a discipline in graduate education level. The other had a big history in mathematics teacher education and also was established with the aim of training mathematics university teachers in the era of shortage of mathematics university teachers and quantitative development of mathematics discipline in higher education in Iran. Besides, they both have high influence on education of future mathematics university teachers in Iran since they educate many students in graduate level in mathematics. Therefore, It was believed that these universities were good indicators of mathematics university education in Iran.

The respondents of this study were 19 PhD students and 8 professors in mathematics discipline which were selected from these two universities. Professors and PhD students were sources of data since it was assumed that they could explain about their experiences both as students and teachers. They selected both in pure and applied mathematics and they were on a spectrum from juniors to seniors both in PhD students and professors. Data were gathered mainly through semi structured interviews about experiences of teaching from respondents. They were analysed through coding and making theme(Creswell,2008). The process of gathering data has continued until the saturation of findings from analysis of data. In total, 19 PhD students and 8 professors cooperated in this research.

RESULTS

PCK in this study could be explained in 4 main and 3 contextual themes. First theme is "mathematics syntactic knowledge". Two sub-themes have been found which would explain this theme. Respondents in this research said the main thing in teaching mathematics is encouraging students to learn mathematics and it is based on explaining what the "application of the mathematics concept" is? Analysis of data showed that application has two means for them: application in the real world, application in other disciplines and application in mathematics. Furthermore they said that they would try to make connections between students' knowledge and mathematical content through focusing on the "main idea behind a mathematics problem".

Therefore not only mathematics professors should know mathematics concepts, theorem and formula, but also they should be aware of applications of mathematics concepts and main idea behind it. To have these two knowledge, a mathematics professors should know the evolution of concepts in a coherent network and this

led us to conceptualize mathematics syntactic knowledge for this theme. Mathematics as a discipline has two structures: substantive structure in mathematics which refers to concepts, theorem, and formula and... in mathematics and syntactic structure in mathematics which refers to the methods of how the concepts of mathematics would be developed (Schwab, 1964).

Second theme is “knowledge about students”. We found out two sub-themes which would explain this theme. One important thing that respondents referred to was to know what is the “major” of their students is and which “grade” are they. Since mathematics would be taught for students in different majors (for example engineering, science, humanities, mathematics and ...), professors should engage with students with different *disciplinary culture*. One of the respondents in this study said:

When I am teaching, I would try to find problems which are related to their majors. For example in chemistry students class, I would try to find what the application of this concept is in the chemistry and try to find or make problems and examples related to them.

The other respondent said:

Most engineering students would like to see the application of mathematics concepts, especially mechanically and physically applications. But in humanities, like a management student would like to know what is the application of mathematics concepts in management. In mathematics, students would see themselves as the specialist of mathematics and you could teach pure theorem and talk about the historical evolution of mathematics concepts in the mathematics body of knowledge. But this is boring for engineering or humanities students.

Respondents also referred that teaching is different in undergraduate or graduate student. One of them said:

Teaching in graduate level is like surfing in a large ocean because you have to introduce a broad variety of concepts to make students find different research questions. But in undergraduate level you have to teach like swimming in a deep river.

The other sub-theme related to this theme is to encounter with “students’ misconceptions and learning difficulties” which was explained by Shulman(1986,1987) too.

Third theme was “knowledge about mathematics curriculum planning”. The first sub-theme which resulted in this theme was “knowledge about mathematics problems”. Since the main component of mathematics content is problem, many respondents introduced this kind of knowledge. They revealed that they should have knowledge about problems which encourage students’ interest to learn mathematics. To do that one of the respondent said:

I would try to find problems which are the historical problem in the mathematics and try to make students in a natural context to engage with that problem and create the concept.

The other respondent said that he uses interdisciplinary problems and the other one told us she uses problems which seems complicated but the solution of them are easy and needs consideration.

After finding the elements of content, professors should integrate these elements and problems to “make a coherent and meaningful content”. To do that, analysis of data showed they would try to make the content related vertically and horizontally.

About horizontal relationship, most respondents explained they would try to follow teaching a concept with a starting point of its story and to introduce why this concept is important and how this was created in the beginning and what the evolution of this concept is. They also explained they would help the students to work independently with the new concept gradually. About the vertical relationship, one of the respondents explained:

We have numerical analysis in 3 levels: bachelor, M. Sc and PhD. The goal of this subject is error analysis, but in bachelor we want to find a point, in M.Sc we would try to find a line and in PhD we want a function. To work on that, we need general mathematics analysis knowledge in bachelor, real analysis knowledge in M.Sc and functional analysis knowledge in PhD.

The last sub-theme of this theme is “to make the content appropriate with students”. In this sub-theme analysis of data defined two approaches: some of respondents would design the content based on the formal intended curriculum and then try to make it appropriate for students. Minority of respondents would start with students. They concentrate on the main idea and concepts of lesson and let the students to make limit of content.

The fourth theme is “knowledge about creating an influential teaching-learning environment”. This theme has 7 sub-themes. The first one is “knowledge about different representation approaches” like teaching from intuition to abstract, problem based teaching which starts from an unknown position, connected to application world and many different strategies in teaching. The second one is “knowledge about how to say and how to write”. Since one of the most important tools in representation in a mathematics classroom is writing, it is really important to know how to write mathematics. One of the respondents introduced this sub-theme in his professor’s teaching:

He knew how to use the board to make connection between concepts. For example he cleaned board but let to remain some central concepts, explanation or theorem. Afterwards, while we were in the middle of a problem and we did not know how to continue, he referred to that concept or explanation or theorem on the board and highlighted central concepts which helped us to solve the problem. He was really professional to use the board. It is like an art in teaching mathematics.

The third sub-theme is “knowledge about how to engage students in teaching-learning mathematics”. One of the respondents said:

Learning by doing is the nature of learning mathematics, so students should be engaged in this process actively otherwise they would not learn simply.

In relationship with this sub-theme, we found out the fourth one as “knowledge about giving feedback to students” and evaluate their learning which make them engaged in teaching-learning process in mathematics classroom.

The next sub-theme was “knowledge about using information communication technology(ICT) in teaching”. Analysis of data announced that professors use ICT in two approaches: using from the general aspects of ICT like using Power point to make abstract concepts more visual and also using specific mathematics software like Matlab or Mathematica. One of the respondents explained:

One of the problem in teaching matrices to students is that they are afraid of working with huge matrices. So I use Matlab software to make an environment for students to work with them and this reduces their fear from working with those matrices.

The sixth sub-theme is “knowledge about using aesthetic sense in teaching”. Most of respondents referred to body language as one component of this sub-theme. One of them believed that professors should be like actors on the scene. More, using some jokes, cartoons, poems, autobiographies of mathematicians and animations also were introduced by respondents. The last sub-theme of this theme is “classroom management”. The respondents referred to the proportional relationship between students and professors as one component in this sub-theme. Also time management has been referred as the other component.

Analysis of data also showed 3 contextual themes which influence on PCK: “nature of subject”, “professor’s features” and “terms of learning atmosphere”.

The nature of subject influences on teaching-learning of that. In this study respondents referred to two main nature for mathematics subjects: pure in subjects like algebra or analysis and applied in subjects like numerical analysis and general mathematics. Professor’s features, both inherent(like appearance, voice, gender, ...) and acquisitive(like moral aspects, enthusiasm, hard working, ...) also consequences on teaching-learning mathematics. Furthermore, terms of atmosphere of learning, both physically and socio-culturally would influence PCK. Physically terms means the size of classroom, number of students, technological terms in class and so on which seem to be obvious. Socio-cultural terms are more complicated and it could be explained through three sub-themes. The first one is socio-cultural beliefs about teaching-learning mathematics. It means that what the society think about and need from mathematics professors? One of the respondents explained:

When I was a young professor, it was a belief about mathematics professors to teach without looking on the book or handout. It took me long time to memorize whole the content in my mind. Also when a teacher made mistake, students thought that he is illiterate. But now society beliefs have changed and it is a better situation. But expectations now is to solve whole the problems...

Many of respondents referred to that there is a belief about the professor’s reputation: the more famous, the better teaching.

The second one is educational institution’s requirements. In Iran we have some governmental universities and free universities named Islamic Azad University. The difference between them is that governmental universities are supported with government but in Islamic Azad universities, students should pay for learning. Respondents of this study referred that these two academic systems needs different approaches in teaching-learning mathematics. One of the respondent said:

It is totally different to teach in which kind of universities. If I want to teach in governmental universities I need a higher level of content and I know I could even fail all the students of a class when they are not qualified to pass it. But in Azad universities I could not fail them because university wants me to pass them above a minimum line of being failed. And I should select easier content. So in governmental universities right is with professor unless the opposite of that would be proved but in Azad universities right is always with students unless the opposite of that would be proved.

More we found out should consider educational institutional culture in teaching because even in governmental universities we have different kinds of universities, for example: polytechnics and comprehensive ones which each of them has its requirements.

The last sub-theme was the terms of students. Many respondents admitted that because of the development of higher education in Iran and increase of interest to technical and engineering majors, basic sciences especially mathematics gets less demand. Therefore better students in high schools would be registered in engineering majors. Mathematics students are usually those who are not interested in that. And in other majors, especially humanities there is a belief between students that they are not good at mathematics so they would reject to learn it. Because of these situations, students who are learners in mathematics classroom are not enthusiastic to learn that and this would influence on teaching-learning mathematics.

REFERENCE

- Counts, M. C.(1999). A case study of a college physics professor's pedagogical content knowledge. PhD dissertation of the Gorgia State University.
- Creswell, J. W. (2008). Educational research. Pearson Education International.
- Fernandez-Balboa, J. & Stiehl, J. (1995). The generic of pedagogical content knowledge among college professors. *Teaching and Teacher Education*. 11(3). 293-306.
- Grossman, P.L. (1998). A study in contrast: Sources of pedagogical content knowledge for secondary English. Unpublished PhD dissertation. Stanford University.
- Grossman, P.L. (1990).The making of a teacher: teacher knowledge & teacher education. New York: Teachers College Press.
- Major, C. H. & Palmer, B. (2002). Faculty knowledge of influences on student learning. *Peabody Journal of Education*, 77(3), Pp 138-162.
- Shulman, L.S. (1986). Those who understand: Knowledge growth in teaching. *Educational Researcher*, 15(2). 4-14.
- Shulman, L. S. (1987). Knowledge and teaching: Foundations of the new reform. *Harvard Educational Review*, 57. 1-22.
- Schwab, J. (1964). Structure of the disciplines. In G. W. Ford and L. Pugno (Eds.), *The structure of knowledge and the curriculum*. Skokie, IL: Rand McNally.

ORTAOKUL 7. SINIF ÖĞRENCİLERİNİN ATOM KAVRAMI HAKKINDAKİ KAVRAM YANILGILARI

THE MISCONCEPTION OF ATOM IN SCONDARY SCHOOL GRADE 7 STUDENTS

Yrd.Doç.Nuriye KOÇAK
Necmettin Erbakan Üniversitesi

Tuba AKDAĞ
Necmettin Erbakan Üniversitesi

Ahmet YARAROĞLU
Necmettin Erbakan Üniversitesi

Bilal BERGİN
Necmettin Erbakan Üniversitesi

ÖZET: Bu çalışma ortaokul 7. sınıf öğrencilerinde atom kavramı hakkındaki kavram yanlışlarını ortaya çıkarmak amacıyla gerçekleştirilmiştir. Bu amaçla atom konusunda uzman görüşü alınarak 3 aşamalı 8 sorudan oluşan kavram yanlışlığı testi oluşturulmuştur. Kavram yanlışlığı testi Konya ilindeki 350 7. Sınıf öğrencisine uygulanmıştır. Güvenirlilik uygulamasından elde edilen veriler SPSS 21 paket programında analiz edilmiştir ve KR20 güvenirliliğinin 0.65 olduğu saptanmıştır. Test uygulaması sonucunda öğrencilerde atomun bölünemez, gözlemlenemez ya da mikroskop ile doğrudan gözlemlenebilir olduğu, elektronların katmanlara yerleşmiş şekilde bulunduğu, maddenin fiziksel özelliklerini(genleşme, iletkenlik, renk...) atomun oluşturduğu, atomun elektron hareketlerinden dolayı canlı olduğu yanlışları ortaya çıkmıştır. Ayrıca atom modellerinden öğrencilerin en doğru model olarak Bohr atom modelini seçtiği tespit edilmiştir. Elde edilen verilere göre bazı önerilerde bulunmuştur.

Anahtar sözcükler: Atom, Kavram yanlışlığı, Elektron

ABSTRACT: In this present study, We have seen the concept of atoms was carried out to reveal the misconceptions of secondary school grade 7 students. For this case, an expert opinion was taken, the concept of 8 questions based three-step of atoms was lead to misconceptions. The misconception test in Konya was absolvet from 350 7th grade students. Reliability on the data which were obtained, were analyzed using SPSS 21 software package. The KR20 reliability has been the results, to be 0.65. Testing the applications results of students has been viewed, that atoms are indivisible, can not be observed or with a microscope maybe observed directly. The Atom Electrons settled in layers. Physical property of atoms are expansion, conductivity, color... The way of thinking that a atom is alive, beacuse of its motion conduct to misconceptions. Mean while students has chosen the Bohr atomic model as the correct one. As a result some suggestions were Based on the data.

Key words: Atom, Misconceptions, Electron

ORTAOKUL 7. VE 8. SINIF ÖĞRENCİLERİNİN RASYONEL SAYILAR KONUSUNDAKİ YANLIŞ ANLAMALARI VE KAVRAM YANILGILARI

7th AND 8th GRADES STUDENTS' MISUNDERSTANDINGS AND MISCONCEPTIONS ABOUT RATIONAL NUMBERS

Mehmet Ali ÇELİK
Necmettin ERBAKAN Üniversitesi
mcelik@konya.edu.tr

Osman BENİBİL
Necmettin ERBAKAN Üniversitesi
o_benibil@yahoo.com.tr

Hasan Yasin TOL
Necmettin ERBAKAN Üniversitesi
hasanyasintol@gmail.com.tr

ÖZET: Araştırmanın amacı, ortaokul 7. Ve 8. Sınıf öğrencilerinin rasyonel sayılar konusundaki yanlış anlamalarının ve kavram yanlışlarının ortaya çıkarılmasıdır. Araştırmanın evreni Konya ilidir. Örnekleme ise evreni temsil edecek şekilde Konya'nın çeşitli bölgelerinden seçilmiş üç okulun 7. Ve 8. sınıfında okuyan 453 öğrenci oluşturmaktadır. Veriler, araştırmacılar tarafından hazırlanmış ve güvenilirliği hesaplanmış üç aşamalı test ile toplanmıştır. Testteki her soru için frekans tablosu oluşturulmuştur. Araştırma sonunda öğrencilerin genellikle devirli ondalık sayıların tanımı ve rasyonel olarak yazılması, kesirlerin şekillerle ifade edilmesi ve rasyonel sayılarda dört işlem konularında kavram yanlışlığı ve yanlış anlamalara sahip oldukları görülmüştür.

Anahtar sözcükler: Rasyonel sayılar, kavram yanlışlığı, yanlış anlamalar, matematik eğitimi

ABSTRACT: The aim of this study is to determine the 7th and 8th grades students' misunderstandings and misconceptions about rational numbers. The universe of research is the city' Konya'. The paradigm is 453 secondary school students who were chosen from different regions of Konya with the aim of representing the universe. The data was collected by three step multiple choice questions whose reliability was counted. At the end of the research, it has been recognized that the students usually have misunderstandings and misconceptions about the definition and rational explanations of repeating decimal numbers, expressing the fractions by shapes and four arithmetical operations with rational numbers.

Key words: rational numbers, misconceptions, misunderstanding, mathematics education

SELF-CONCEPT AND SELF-EVALUATION IN THE TRANSITION FROM PRIMARY TO LOWER SECONDARY EDUCATION

Pranvera KRAJA

In this article I'll present theoretical concepts and empirical results of self-concept and self-esteem of the children in transition from primary school to lower secondary education (LSE). Through the evidences from research literature, this article, aims to provide answers to such questions: How and what aspects of self-concept and self-esteem of children develop and change during childhood and adolescence? Is there a correlation between levels of self-concept and self-assessment that the child has for him and his academic achievements? Why is it important to maintain high levels of self-concept and self-esteem of the child for the life in general, and for the school life in particular? Studies of the last two decades have shown that changes in self-concept and self-esteem of the child are strongly correlated with pupils' academic achievements. Keeping positive levels of self-concept and self-esteem, would facilitate the difficulties of the child's adjustment at the new school.

Keywords: school transition, self-concept, self-esteem, impact, lower secondary education.

ÇEVİRİMİÇİ ÖĞRENME ORTAMLARINDA KULLANILABİLİRLİK: BİR LİTERATÜR TARAMA ÇALIŞMASI

USABILITY IN THE ONLINE LEARNING ENVIRONMENTS: A LITERATURE REVIEW STUDY

İsmail ŞAHİN
Necmettin Erbakan Üniversitesi
isahin@konya.edu.tr

Mustafa Tefrik HEBEBÇİ
Necmettin Erbakan Üniversitesi
mustafahebeci@gmail.com

İsmail ÇELİK
Necmettin Erbakan Üniversitesi
icelik@konya.edu.tr

ÖZET: Bilgisayar ve internet teknolojilerindeki hızlı değişim insanların hayatlarında bir takım değişikliklere neden olmuştur. İnsanlar günlük hayatta yaptıkları işleri bilgisayar sistemleri aracılığıyla artık daha kolay ve kısa yoldan gerçekleştirebilmektedir. Tüm bu kolaylıkların yanı sıra geliştirilen sistemlerin kullanıcı odaklı olmaması, kullanıcıların bu sistemlerde sorunlar yaşamalarına sebep olmaktadır. Bu sorunlar kullanılabilirlik kavramını ortaya çıkarmıştır. Kullanılabilirlik, bir ürünün belirli kullanıcılar tarafından belirli amaçlar doğrultusunda etkili, verimli ve belirli bir kullanım çerçevesinde memnuniyetle kullanılabileceği derecesi olarak tanımlanmaktadır. Bu çalışmada kullanılabilirlik değerlendirme yöntemleri ve türleri ile literatürde yer alan çevrim içi öğrenme ortamlarında yapılmış olan kullanılabilirlik çalışmaları ele alınmıştır. Yapılan araştırma sonucunda, incelenen çalışmalarda kullanılan kullanılabilirlik değerlendirmelerinin birçoğunun uzman temelli ve kullanıcı testleri yaklaşımlarıyla gerçekleştirildiği görülmektedir.

Anahtar sözcükler: kullanılabilirlik, insan bilgisayar etkileşimi

ABSTRACT: Rapid changes in computer and internet technology have led to a number of changes in people's lives. People can easily complete their daily tasks through computer systems. However, users may experience problems in using these systems because of their lack of user-oriented characteristic. This problem has revealed the concept of usability. The usability is the extent to which a product can be used by certain users to achieve identified goals with effectiveness, efficiency, and satisfaction in a specified context. In this study, usability evaluation methods and types are investigated. Also, usability studies in online learning environments discussed in the literature are reviewed. As a result of this research conducted, many of usability assessments are made with expert-oriented and user testing approaches.

Keywords: usability, human computer interaction

Not: Bu çalışma, Türkiye Bilimsel ve Teknolojik Araştırma Kurumu (TÜBİTAK) tarafından desteklenen 113K302 numaralı "FATİH Projesi Uygulamalarının Teknolojik-Pedagojik-Alan Bilgisi (TPAB) Çerçevesinde Gözlemlenmesi ve Çevrimiçi Örnek Olay Kütüphanesi Oluşturulması" başlıklı proje kapsamında hazırlanmıştır. Yazarlar, bu çalışmaya desteğinden dolayı TÜBİTAK'a teşekkür eder. Bu çalışma, ikinci yazarın proje kapsamında yapılan yüksek lisans tezinden üretilmiştir.

GİRİŞ

Hızla gelişen teknoloji, insanların hayatlarını kolaylaştırmış ve bazı alışkanlıkların da farklılaşmasına sebep olmuştur. Özellikle 1990'lı yılların başında Web teknolojisinin ortaya çıkışı ile birlikte, bilgisayar günümüzün en etkili bilgi iletişim aracı olarak tüm dünyada büyük bir hızla yaygınlaşmış, eğitimden ticarete, sağlıktan kamuya kadar akla gelebilecek tüm sektörlerde hizmet anlayışında büyük bir değişime sebep olmuştur.

Web teknolojisindeki hızlı gelişmeler insanların her zaman yapmış olduğu fatura ödeme, alışveriş yapma ve para transferi gibi işleri daha farklı ve daha kolay yoldan gerçekleştirmelerine olanak sağlamıştır. Web teknolojisindeki bu gelişmeler sağladığı birçok yararın yanı sıra bazı sorunları da beraberinde getirmiştir. Bu sorunların başında bu teknolojilerin herkese ulaştırılması ve herkes tarafından kolay bir biçimde kullanılabileceği görülmektedir. Geliştirilen yazılımların sadece geliştirici kişilerin anlayacağı şekilde tasarlanması kullanıcılar

açısından büyük bir sorun teşkil etmekte ve ilgili yazılımın önemini kaybetmesine neden olmaktadır. Bunun gibi sorunlar İnsan Bilgisayar Etkileşimi (İBE) ve kullanılabilirlik kavramlarının ortaya çıkmasına sebep olmuştur.

İnsan Bilgisayar Etkileşimi (İBE) ve Kullanılabilirlik

İBE, etkileşimli teknolojilerin tasarım, geliştirilme, değerlendirme ve uygulama kısmı ile ilgilenen disiplinler arası bir çalışma alanıdır. İBE'nin nihai amacı insanın teknolojiye değil, teknolojinin insana ayak uydurmasını ve üretilen ürünlerin herkes için tasarım ilkesi ile üretilmesini sağlamaktır. (Çağiltay, 2011). Web teknolojisinin hızlı gelişimi İBE'nin önemini artırmış ve bu konudaki kullanılabilirlik çalışmalarının daha yoğun bir biçimde gerçekleşmesine sebep olmuştur. Nielsen (2012)'e göre kullanılabilirlik kullanıcı arayüzlerinin ne derece kolay kullanıldığını değerlendirir; öğrenilebilirlik, etkililik, akılda kalıcılık, hata ve tatmin edicilik gibi bileşenlerden oluşan bir kavramdır. Kamu Kurumları İnternet Siteleri Standartları ve Önerileri Rehberi (2014)'ne göre ise kullanılabilirlik, bir uygulamada belirlenen işlerin, hedef kitle olarak belirlenen kullanıcılar tarafından, gerekli eğitim ve teknik desteğin verilmesiyle, uygun şartlarda kolaylıkla ve etkili biçimde kullanılabilmesi olarak tanımlanmaktadır. Kullanılabilirlik geliştirilen ürünün farklı özelliklerini içinde barındırmaktadır. Ayrıca, kullanılabilirlik ürün özelliklerin değerlendirilmesi ile anlam kazanmaktadır (Evcil ve İslim, 2012). Tablo 1'de kullanılabilirlik kavramı ile ilgilenen bilim adamları tarafından belirlenen özellikler yer almaktadır (Jeng, 2005):

Tablo 1: Kullanılabilirlik Özellikleri

Yazar	Özellikler
Booth (1989)	Kullanışlılık, etkililik, öğrenilebilirlik, tutum
Brinck ve ark. (2002)	Fonksiyonel doğruluk, etkili kullanım, öğrenme kolaylığı, hatırlama kolaylığı, hata toleransı, öznel memnuniyet
Clairmont ve ark. (1999)	Başarılı öğrenme ve bir hedefi başarmak için bir ürünü kullanma
Dumas & Redish (1999)	Çabuk ve kolay bir şekilde görevleri gerçekleştirme
Furtado ve ark. (2003)	Kullanım kolaylığı ve öğrenme
Gluck (1997)	Kullanışlılık ve faydalılık
Guillemette (1995)	Görevleri yerine getirmek için hedef kullanıcı tarafından etkili kullanım
Hix ve Hartson (1993)	İlk performans, uzun süreli performans, öğrenilebilirlik, kalıcılık, gelişmiş özellik kullanımı, ilk etki, uzun dönem kullanıcı memnuniyeti
ISO (1994)	Etkililik, etkinlik, memnuniyet
Kengeri ve ark. (1999)	Etkililik, memnuniyet, öğrenilebilirlik, kullanışlılık
Kim (2002)	Arayüz etkililiği
Nielsen (1993)	Öğrenilebilirlik, etkililik, hatırlanabilirlik, hatalar, memnuniyet
Oulanov ve Pajarillo (2002)	Etki, etkinlik, kontrol, yardımseverlik, uyum yeteneği
Shackel (1984)	Kullanım kolaylığı, etkililik
Shackel (1986, 1991)	Etkililik, öğrenilebilirlik, esneklik, kullanıcı tutumu

Arayüz Değerlendirme Yöntemleri ve Kullanılabilirlik Testleri

Çağiltay (2011)'a göre kullanılabilirlik değerlendirme yöntemleri, tür ve yaklaşım olmak üzere ikiye ayrılmaktadır. Yaklaşım yöntemleri ele alındığında kullanılabilirlik değerlendirme yöntemleri; Tasarım Rehberleri Temelli, Kullanıcı Temelli, Uzman Temelli ve Model Temelli olmak üzere 4'e ayrılmaktadır. Tür açısından ele alındığında ise Süreç içi (Formative/Diagnostic) ve Süreç sonu (Summative/Metrication) olmak üzere 2'ye ayrılmaktadır. Kullanılabilirlik testleri, kullanılabilirliğin değerlendirilmesi istenen ürünün belirli hedef kitlede belirli görevlerin yaptırılması ve bu süreçte kullanıcıdan verimlilik, etkililik ve memnuniyet değerlerinin alınması amacıyla yapılmaktadır (ODTÜ, 2014). Ürünler üzerinde uygulanan kullanılabilirlik testleri, üründe bulunan kullanım sorunlarını, tasarım problemlerini ve kullanıcıyı rahatsız eden veya karmaşıklığa yol açan unsurları ortaya çıkaran kritik uygulamalardır. Çağiltay (2011) kullanılabilirlik değerlendirme yöntemlerini şu şekilde açıklamıştır:

Kullanılabilirlik Test Türleri

Süreç içi Testler (Formative/Diagnostic): Geliştirilecek olan ürünün üretim süreci içinde yapılan değerlendirme yöntemidir.

Süreç Sonu Testler (Summative/Metrication): Ürün ortaya çıktıktan sonra yapılan testlerdir. Bu testler ile ürünün geçerliği sağlanarak genel kullanıma sunulur.

Kullanılabilirlik Test Yaklaşımları

Tasarım Rehberleri: Hazırlanan tasarımlarda tutarlılığı ve uyumluluğu sağlamak için geliştirilen rehberlerdir.

Uzman Temelli (Sezgisel): Geliştirilen ürünün bir uzman tarafından değerlendirilmesidir. 1970'den bugüne birçok sezgisel rehber önerilmiştir. Günümüz arayüzleri içinde en çok kullanılanı hiç şüphesiz Nielsen (2005) tarafından geliştirilen Jacob Nielsen'in 10 Kullanılabilirlik Sezgiseli'dir.

Kullanıcı Testleri: Bu yöntem gerçek kullanıcılara, gerçek bir arayüz sistemi karşısında, gerçek görevler verilerek gerçekleştirilir. Gerçek kullanıcılarla yapılan kullanılabilirlik testleri için farklı yöntemler kullanılabilir. Bu yöntemler; kullanıcının testi yaparken sergilediği esneme, gerinme gibi gözlemlenen davranışlar olabildiği gibi kullanıcıların uygulama sırasında nasıl bir yol izlediklerini sesli düşünme yolu ile (think aloud) kullanılabilirlik uzmanlarına aktarması da istenebilir. Böylece elde edilen ses veri kayıtları diğer test verileri ile birlikte değerlendirilebilmektedir. Bir diğer yöntemde ise veriler göz-izleme (eye-tracking) cihazları kullanılarak elde edilmektedir. Bu yöntem ile çalışma alanı ile ilgili oldukça detaylı veriler elde edilebilmektedir.

Model Temelli: Bu yaklaşımda kullanıcıların bilişsel ve fiziksel davranışları modellenmeye çalışılır ve kullanıcının davranışlarının bu modele uygun olup olmadığını ve modelin daha hızlı nasıl çalıştırılabileceği gibi konular değerlendirilmektedir. Bu değerlendirme işlemini yaparken fiziksel davranışların modellenmesinde genellikle “Fitts” kanunu (Fitts, 1954), bilişsel davranışların modellenmesinde ise “Bilgi İşleme Modeli” temel alınmaktadır.

Gelişen teknoloji ile birlikte büyük bir öneme sahip olan kullanılabilirlik ile ilgili Türkiye’de ve dünyada birçok çalışma yapılmıştır. Özellikle her geçen gün çevrim içi ortamlarda birçok kullanılabilirlik çalışmaları gerçekleştirilmekte ve daha kullanılabilir web sayfaları oluşturulması için çalışmalar sürdürülmektedir. Bu araştırmada çevrimiçi ortamlarda yapılan kullanılabilirlik çalışmalarından bir kısmını içermektedir. Araştırmada yer alan yayımlar; ProQuest, SAGE Journals, Google Scholar, Taylor & Francis Online Journals ve YÖK Ulusal Tez Merkezi veri tabanlarından “web kullanılabilirlik, kullanılabilirlik, usability ve web usability” anahtar kelimeleriyle erişilen tez, makale ve bildirilerden oluşmaktadır.

Literatürde Yer Alan Çevrimiçi Ortamlarda Kullanılabilirlik Çalışmaları

Giritli tarafından 2007 yılında Işık Üniversitesi’nde yüksek lisans tezi olarak gerçekleştirilen çalışma ile Türkiye’de faaliyet gösteren bazı e-ticaret sitelerinin kullanılabilirliklerinin değerlendirilmesi yapılmıştır. Üç ayrı kategoride yer alan toplam 28 sorudan oluşan bir anket 35 kişiye uygulanmış ve toplanan veriler ANOVA istatistiksel yöntemiyle analiz edilmiştir. Çalışmanın sonucunda incelenen web sayfalarında tecrübeli bilgisayar kullanıcılarının bile bazı noktalarda zorlandıklarını ve bu yüzden sayfaların genel hatları ile çok kullanışlı olmadığı ortaya çıkmıştır.

Gürses’in 2006 yılında Hacettepe Üniversitesi’nde doktora tezi olarak gerçekleştirdiği araştırma, ulusal ölçekte ve geniş bir kullanıcı kitlesine hizmet sunan Ulusal Akademik Ağ ve Bilgi Merkezi (ULAKBİM) web sayfasında gerçekleştirilmiştir. Araştırmada öncelikle ULAKBİM web sayfasının aktif arayüzü kullanıcı algı ve tutumlarına etki eden faktörlere göre optimize edilmiş ve yeniden tasarlanmıştır. Mevcut site ve kullanıcı merkezli hazırlanan “Prototip site” kullanıcı performansı ve memnuniyeti açısından fark olup olmadığı 50 kişinin katıldığı deneysel bir araştırma modeli çerçevesinde nitel ve nicel ölçümler aracılığı ile karşılaştırılmalı olarak incelenmiştir. Yapılan analiz sonucunda katılımcıların kullandıkları site arayüzlerine göre arayüz kullanım etkinlikleri, verimlilikleri ve memnuniyetleri arasında anlamlı bir fark ortaya çıkmıştır.

Berkman’ın (2006) Bahçeşehir Üniversitesi’nde yüksek lisans tezi olarak gerçekleştirdiği çalışmada, araştırmanın yürütüldüğü dönemde en çok ziyaret edilen 20 haber sitesi, kullanılabilirlik ölçütleri ve arayüz özellikleri açısından değerlendirilmiştir. 10 kişilik uzman bir test grubu tarafından sağlanan veriler ile yapılan analizlerin yanı sıra, yine aynı test grubunun sağladığı empirik veriler ile 20 kişilik uzman olmayan bir gruptan aynı yolla sağlanan verilerin ortalamalarının dağılımları karşılaştırmalı olarak ortaya konmuştur. Çalışma sonucunda, ele alınan sitelerin bazılarında kullanılabilirlik ile ilgili problemlere rastlanmıştır. Ancak, sitelerin çoğunluğunda yinelenen ve kullanıcıları etkileyen belirgin bir sorun görülmemiştir.

İlgili literatürde bir çalışma da İşbulan’ın (2008) Sakarya Üniversitesi’nde yapmış olduğu yüksek lisans tez çalışmasıdır. Çalışma kapsamında, katılımcılar, Sakarya Üniversitesi Adapazarı Meslek Yüksek Okulu Uzaktan Eğitim Bölümü’nde öğrenim gören 1512 öğrenciden oluşmaktadır. Çalışmaya katılan öğrencilerden üniversiteye ait uzaktan eğitim web sitesini kullanılabilirlik açısından değerlendirmesi istenmiştir. Bu değerlendirmeyi gerçekleştirmek için bir ölçek geliştirilerek öğrencilere uygulanmıştır. Değerlendirmeye uygun olan 1229 anket ile cinsiyet, yaş, bölüm, üniversitedeki yılları ve yaşadıkları coğrafi bölgelere göre anlamlı bir farklılık olup olmadığı araştırılmıştır. Bulunan sonuçlar doğrultusunda web sayfasının genel olarak öğrencilere tarafından kullanılabilir olduğunu ortaya çıkarmıştır. Çalışmada bulunan diğer bulgular şu şekilde özetlenebilir:

1. Araştırmaya katılan bayanların bazı faktörlerde erkeklere oranla,
2. Yaşları küçük olan katılımcıların bazı faktörlerde diğer katılımcılara oranla,
3. Mekatronik ve işletme bölümü öğrencilerinin diğer öğrencilere oranla,
4. Üniversitede bulunduğu yıl göz önüne alındığında ise 1. Sınıfta okuyan öğrencilerin diğer öğrencilere oranla,
5. Yaşadığı coğrafi faktörlere göre ise akdeniz bölgesinde yaşayan öğrencilerin bazı faktörlerde diğer bölgelerde yaşayan öğrencilere oranla web sayfasının kullanılabilirliğinden memnun olmadıkları bulunmuştur.

Bir diğerk çalıřma da ise bir e-devlet uygulaması olan Türk Sosyal Güvenlik Kurumlarının (SSK, Emekli Sandığı, Baę-Kur) web sayfalarının kullanılabilirlięi ve kullanıcı kabulünün deęerlendirmesi yapılmıřtır (Öndin, 2007). Bu çalıřma, mevcut SGK kurumlarından birine dâhil farklı meslek, yař, eęitim düzeyi ve bilgisayar becerilerine sahip 45 yetiřkin ile gerçekteřirilmıřtir. Çalıřmada öncelikle katılımcıların SGK web sayfalarında serbest olarak gezmeleri istenmiř ve sonrasında belirlenen 4 görevi gerçekteřirmeleri istenmiřtir. Kullanılabilirlik çalıřması her katılımcıyla birebir yürütölmüř ve arařtırmacı bir gözlem formu tutmuřtur. Katılımcıların web sayfasındaki tüm iřlemleri ve sesleri kaydedilmiřtir. Katılımcılar görevleri gerçekteřirdikten sonra veri toplama araçlarını doldurmuřlardır. Katılımcıların web sayfalarıyla ilgili yararlılık ve kullanım kolaylıęı algılarını ölçmek için Davis (1989) tarafından geliřtirilen özgün formdan arařtırmacı tarafından uyarlanan Teknoloji Kabul Ölçeęi, göreve özel kullanılabilirlięi ölçmek için Lewis (1991)'in geliřtirdięi özgün formdan arařtırmacı tarafından uyarlanan Senaryo Sonrası Anketi (SSA), katılımcıların web sayfasındaki iřlemlerini kaydetmek için arařtırmacı tarafından geliřtirilen Gözlem Formu ve katılımcıların kiřisel bilgileri ve bilgisayar kullanımları hakkında bilgi toplamak için Demografik Bilgiler ve Bilgisayar Deneyim Formu kullanılmıřtır. Yapılan veri analizleri sonucunda kullanılabilirlik ve kullanıcı kabulü arasında anlamlı bir iliřki ortaya çıkmıřtır. Arařtırmada ayrıca kullanılabilirlięin e-devlet hizmetlerinin daha geniř kitlelere ulařtırılmasında önemli bir faktör olduęu bulgusuna ulařılmıřtır. Arařtırma, e-devlet web sayfası yetkililerinin bu hizmetlerin tasarımına yönelik kararlar alırken kullanılabilirlik faktörünü dikkate almalarının gerekli olduęunu önermektedir.

Bařka bir çalıřmada ise çevrimiçi bir öğrenme ortamı olan Alternatif Web Kurs Yapılarının Kullanılabilirlięi deęerlendirilmiřtir (Ingram, 2003). Arařtırmacı tarafından oluřturulan çevrimiçi eęitim ortamlarının kullanılabilirlięi oluřturulan görev listesi ile deęerlendirmiřtir. Çalıřmada katılımcıların web ve internet bilgileri ve deneyimleri bir anket aracılıęıyla toplanmıř sonrasında rasgele bir řekilde katılımcıların belirlenen görev listesinde yer alan görevleri gerçekteřirmeleri istenmiřtir. Katılımcılar tarafından uygulanan her ařama arařtırmacı tarafından video kaydına alınmıřtır. Çalıřma temel kullanılabilirlik testinin özellikle biçimlendirici deęerlendirmenin bir parçası olarak, tüm eęitim ve öğretim siteleri için büyük bir önem tařıdıęını ortaya çıkarmıřtır. Çalıřma, web sayfalarının hazırlanırken öğrencilerin gözünden bakılarak hazırlanmasının öğrencilerin ders materyallerine olan konsantrasyonuna katkı sağladığına öne sürmektedir. Ayrıca çalıřma sonucunda eęitsel sitelere kullanılabilirlik testinin nasıl uygulanacaęı ve gelecekte bu tarz sitelerin oluřturulmasında hangi yolların izlenmesi gerekeceęi ile ilgili öneriler sunulmuřtur.

2010 yılında Rivera ve ark. popüler iki sosyal aę sitelerinden biri olan Facebook ve MySpace'i tasarım ve kullanılabilirlięini sezgisel olarak deęerlendirmişlerdir. Çalıřma üç ařamadan oluřmaktadır. İlk kısımda sosyal medyanın tarihçesi, web tasarımında kullanılabilirlik, Nielsen'in (2005) sezgisel kullanılabilirlik yaklařımından bahsedilmiřtir. İkinci kısımda sezgisel kullanılabilirlik ve bunun kullanıcıların başarılarını artırmak için sosyal aę sitelerine nasıl entegre edileceęinden bahsedilmiřtir. Son olarak kullanılabilirlik sezgisel dayalı Lund (2001) tarafından geliřtirilen anket 35 katılımcıya uygulanmıřtır. Uygulanan kullanılabilirlik anketi Facebook ve MySpace web sayfalarını sadelik, kullanıřlılık, iřlevsellik, tutarlılık, yeterlilik, tatmin, davranıř bakımından deęerlendirilmesini sağlamıřtır. Çalıřma sonunda iki web sayfası arasında önemli farklılıklar bulunmuřtur. Yapılan analizler iki web sayfasının da tutarlılık ve yeterlilik açısından farklı olmadıęını ancak Facebook'un 6 kullanılabilirlik faktörü açısından MySpace'e oranla daha kolay olduęunu ortaya çıkarmıřtır.

Ersoy (2004) tarafından yapılan çalıřmada Orta Doęu Teknik Üniversitesi (ODTÜ), Bilgisayar ve Öğretim Teknolojileri Eęitimi (BÖTE) bölümü 2003 yılı bahar döneminde "Programlama Dilleri II" dersi için geliřtirilen çevrimiçi destek sisteminin kullanılabilirlik deęerlendirmesi yapılmıřtır. Çalıřma kapsamında testin gereklilięi açıklanmıř, testin planlanması ve uygulanması anlatılmıř, karřılařılan güçlükler ve izlenen stratejiler belirtilmiřtir. İlgili çalıřma 4 gözlemci tarafından 10 öğrenci ile birebir olarak gerçekteřtirilmiřtir. Katılımcılara web sayfasında gerçekteřirmeleri için 12 sorudan oluřan bir görev listesi verilerek veri toplama iřlemi gerçekteřtirilmiřtir. Yapılan kullanılabilirlik testinin sonuçları, tasarımcıya site hakkında ve kullanıcılar hakkında önceden tahmin edemedięi veya farklı düřündüęü konuları göstermiřtir.

Wan Azlan Wan Hassan ve ark. tarafından 2011 yılında yapılan çalıřmada Malezya Yüksek Öğretim Enstitüsü bünyesinde yer alan ve üniversite personeline yardımcı olmak (ders yönetimi, finansal bilgiler, konaklama ve dięer bilgileri bünyesinde barındıran) için geliřtirilen akademik yönetim sisteminin kullanılabilirlięini; öğrenilebilirlik, verimlilik, hatırlanabilirlik ve memnuniyet açısından deęerlendirilmiřtir. Veriler 150 katılımcıya daęıtılan 5 kategori altındaki sorular aracılıęıyla toplanmıřtır. Elde edilen sonuçlar sistemin bir takım eksiklerini ortaya çıkarmıř ve bu eksiklerin giderilmesi için bir takım öneriler sunmuřtur. Bu tarz sistemlerin tasarım ařamasında özellikle son kullanıcının da fikirlerinin alınarak sistemin geliřtirilmesi gerektięi öne sürölmüřtür.

Literatürde kullanılabilirlikle ilgili bařka bir çalıřma da, George (2005) tarafından gerçekteřtirilen Carnegie Mellon Üniversitesi Kütüphanelerinin web sayfasıyla ilgili çalıřmadır. Arařtırmada, web sayfasının tasarım ařaması öncesinde ve sonrasında çeřitli yöntemlerle deęerlendirilerek eski ve yeni sitenin karřılařtırılması sağlanmıřtır. İlgili çalıřmanın uygulama boyutunda tasarım hazırlanma ařamasına geçmeden ihtiyaçların neler olduęunu öğrenmek için bir çevrim içi anket uygulanmıřtır. Daha sonra tasarıma son řekli verilerek uygulanan

kullanıcı testleri ile süreç tamamlanmıştır. Tasarımın güçlü ve zayıf yönlerini ortaya çıkarabilmek için katılımcılara görev listeleri verilerek bu işlemleri sesli düşünerek gerçekleştirmeleri sağlanmıştır. Çalışma bulguları, sesli düşünme sırasında verilen cevaplarda web sayfasında çok önemli bir sorunun olmadığını ortaya çıkarmıştır. Ancak tasarım yönünde bazı değişiklikler olmuş (yazı tipi, font ve renk gibi) bunlarda katılımcıların istekleri doğrultusunda düzeltilerek daha kullanılabilir bir web sayfasının ortaya çıkması sağlanmıştır.

İlgili alan yazında çalışmalardan biri de Ballard (2010) yapılan bir doktora tezidir. ABD’de bir devlet üniversitesinde uzaktan eğitim programındaki altı çevrim içi ders sayfasının kullanılabilirliği araştırılmıştır. İlgili altı ders uzman ve uzman olmayan tasarımcılar ile ayrı ayrı tasarlanmıştır. Çalışmaya 74 öğrenci katılmıştır. Çalışmadaki veriler nicel ve nitel ölçme araçları ile toplanmıştır. İlk olarak, altı dersin kullanılabilirlik standartları açısından Xerox Sezgisel Değerlendirme Kontrol Listesi (1995) ile veriler toplanmıştır. Daha sonra dersler başlamadan katılımcılara Eachus ve Cassidy (2006) tarafından geliştirilen Bilgisayar kullanım öz yeterlik ölçeği ön test olarak uygulanmıştır.

Stewart, Hong, ve Strudler (2004) tarafından geliştirilen Web tabanlı öğretimin kalitesi ölçeği dersler tamamlandıktan sonra öğrencilerin memnuniyet düzeylerini ölçmek için kullanılmıştır. 29 öğrenci ise sitenin kullanılabilirliği belirlemek için kullanılabilirlik laboratuvarında araştırmaya katılmıştır. İlgili laboratuvarında katılımcılar göz izleme yöntemi, sesli düşünme protokolleri, hata oranları ve görev tamamlama gibi teknikler uygulanmıştır. Çalışmadan elde edilen bulgulara göre, uzmanlar tarafından hazırlanan web sayfalarında kullanıcılar uzman olmayanlarca hazırlanan sitelere göre daha düşük hata oranı ve daha fazla memnuniyet düzeyine sahiptir. Ayrıca, görüşmelerden elde edilen nitel verilere göre uzmanlarca hazırlanan web sayfalarına dair daha olumlu olmuştur.

Lee (2000) tarafından yapılan çalışmada ise, coğrafik bilgi sistemleri web sayfasının kullanılabilirliği kullanıcıların verdikleri oy ve siteye giriş sıklığı açısından incelenmiştir. Veriler web ortamındaki bir anket aracılığı ile toplanmıştır. 51 katılımcı sitenin yüklenme zamanını ve kullanılabilirliğini kendilerine verilen beş görevle puanlamışlardır. Çalışma sonunda, sitede metinsel ifadelerin okunabilirliği ve aranılan bilginin kolay ulaşılabilir olmasının kullanılabilirliği olumlu yönde etkilediği bulgularına ulaşılmıştır. Elde edilen verilere göre, sitenin içeriğinin ortalama yüklenme zamanı site kullanılabilirliğine etkisi olmamıştır.

Bringula ve Basa (2011) tarafından yapılan bir çalışmada Filipinlerdeki bir üniversiteye bağlı fakülte web sayfasının kullanılabilirliğini etkileyen faktörlerin belirlenmesi amaçlanmıştır. Betimsel yöntemin kullanıldığı çalışmada veriler 82 öğretim üyesinden elde edilmiştir. Veriler çoklu regresyon ile analiz edilmiştir. Verilerden elde edilen bulgulara göre, Web sayfası tasarımıyla ilgili faktörlerden sadece bilgi içeriğinin ilgili sitenin kullanılabilirliğini etkilediği sonucuna ulaşılmıştır.

Literatürdeki başka bir çalışmada Hebb ve Adviser-Frick (2005) bir web sayfasının kullanılabilirliğini belirlemek için Ardışık Olasılık Oran Testi kullanmıştır. Çalışmada biçimlendirici değerlendirmenin amacı web sayfasındaki kullanılabilirlik sorunlarını açığa çıkarmaktır. Bununla birlikte, genel değerlendirme sırasında, birincil hedef web sayfası etkinliğini değerlendirmektir. Araştırmaya 25 lisans öğrencisi katılmıştır. Web sayfasının kullanılabilirliğini belirlemek için sesli düşünme protokolü yöntemi kullanılmıştır. Her katılımcı 120 web görevi arasından seçilen 20 görevi yerine getirmesi istenmiştir. Çalışmadan elde edilen bulgulara göre kullanılabilirlik testi yapılmadan önce siteyle ilgili temel sorunların bilinmesi gerekmektedir. Bir web sayfasındaki kullanılabilirlik sorunlarını açığa çıkarmak için daha fazla bilgiye ihtiyaç vardır.

Gülten ve ark. (2003) tarafından gerçekleştirilen çalışmada e-devlet uygulamaları kapsamında kamu Kurumlarına ait web sayfalarının geliştirilmesini sağlayacak bir grup değerlendirme kriterleri oluşturulmuştur. Değerlendirme kriterleri oluşturulurken World Wide Web Konsorsiyumunun “Web İçeriği Erişilebilirlik Rehberi Kontrol Listesi” ve Türkiye Bilimsel ve Teknolojik Araştırma Kurumu Marmara Araştırma Merkezi (TÜBİTAK-MAM) tarafından yayımlanan Kamu Kurumları İnternet Sitesi Kılavuzundan yararlanılmıştır. Araştırmada 24 Kamu Kurumunun web sitesinin ana sayfası (16 Bakanlık ve sekiz Genel Müdürlük/ Başkanlık) sekiz kategori altında toplam 30 kriter açısından değerlendirilmiştir. Araştırma bulguları kamu web sayfaları genel özellikler açısından çoğunlukla belirlenen kriterleri karşılarken, hizmet sunumu, teknik özellikler ve etkileşimli hizmetler konusunda kayda değer oranda eksiklikler göstermektedirler.

Işık ve ark. (2011) Gazi Üniversitesi Bilişim Enstitüsü web sayfasının kullanılabilirlik analizini WAMMI kullanılabilirlik anketini kullanarak 90 katılımcıya uygulamışlardır. Kullanılabilirlik analizinin yanı sıra web sayfasının tasarım ve performans analizi için “HTML Toolbox” ve “Web Page Analyzer” araçları kullanılmıştır. Verilerin analizleri SPSS’de bulunan betimlemeli istatistik, korelasyon, bağımsız örneklemeli t-testi ve tek yönlü varyans analizi teknikleri kullanılarak yapılmıştır. Yapılan analizler web sayfasının kullanılabilirliğinin orta düzeyde olduğunu ortaya çıkarmıştır. Katılımcılar, web sitesinin ilgi çekiciliği ve etkinliği hususunda olumlu yanıtlar vermişler ancak kontrol edilebilirlik, yardım etme ve öğrenilebilirlik konularında kararsız kalmışlardır. Yapılan çalışma da demografik anket bilgileri de değerlendirilmiştir. t- test analizlerine göre bay öğrencilerin bayan öğrencilere göre web sayfasını daha etkin kullandıkları sonucu elde edilmiştir. Katılımcıların internet kullanma yılı arttıkça web sayfasında istedikleri bilgiye daha kolay ulaştıkları sonucu yapılan analizlerden bulunmuştur. “HTML Toolbox” ve “Web Page Analyzer” hazır araçları kullanılarak yapılan

analizler sonrasında resim sayısı, boyutlarının fazla olduğu ayrıca yazım hatalarının mutlaka azaltılması gerekliliği de vurgulanmıştır.

Karahoca ve ark. (2009) geliştirdikleri web tabanlı sınav otomasyon sisteminin öğrenilebilirlik, kontrol edilebilirlik ve tasarım faktörleri açısından sistem kullanılabilirliğini geliştirdikleri yapılandırılmış bir anket formu kullanarak tarama modeli bir araştırma ile incelemişlerdir.. Araştırma meslek liselerinin bilişim teknolojiler ve inşaat teknolojisi bölümünde öğrenim gören 52 öğrencinin katılımı ile gerçekleştirilmiştir. Çalışma sonucunda; öğrenilebilirlik, kontrol edilebilirlik ve tasarım ile memnuniyet derecesi arasında önemli ilişkiler bulunmuştur. Ayrıca kullanılabilirliğe ilişkin öğrenilebilirlik faktörü ile kontrol edilebilirlik faktörü arasında pozitif ve güçlü bir ilişkinin olduğu da ortaya çıkmıştır. Öğrencilerin okudukları bölüm ile kullanılabilirliğe ilişkin öğrenilebilirlik düzeyi arasında ($p < 0.01$) dikkate değer bir ilişki de saptanmıştır.

Başka bir çalışmada ise, Dalcı ve ark. (2008) ODTÜ Kütüphanesi web sayfasının eksik yönlerini belirleyerek hedef kitle doğrultusunda seçilen 8 kullanıcıya bir takım görevler vererek ilgili web sayfasının kullanılabilirlik çalışmasını gerçekleştirmişlerdir. İlgili çalışmada arayüzde sorunlu yerleri test edebilmek için kullanıcıların nereye, ne kadar süre baktıkları bilgisini veren bir göz izleme cihazı kullanılmıştır. Ek olarak klasik kullanılabilirlik çalışması olarak adlandırılan kullanıcıların sesli düşünmesi, görevi gerçekleştirme süresi ve hata sayıları ile hatanın olduğu yerlerin kaydedilmesi gibi yöntemler kullanılmıştır. Çalışma sonucunda hazırlanan yeni arayüzün bazı küçük sorunlar dışında oldukça etkili ve verimli olduğu ortaya çıkmıştır. Kullanıcıların geri bildirimleri ile bu sorunlar da düzeltilmiştir.

Karacan ve Demirtel (2009) tarafından yapılan bir diğer çalışmada Türkiye Tüketici Portalı (TTP) web sitesinin kullanımındaki mevcut durumun araştırılarak ve elde edilen çıktıların kullanılabilirlik açısından değerlendirilmesi ele alınmıştır. Bu doğrultuda çeşitli yaş, cinsiyet ve eğitim grubuna dâhil 15 katılımcı ile bir kullanılabilirlik çalışması gerçekleştirilmiştir. Bu çalışmada, belirlenen 15 katılımcının web sayfasının kullanımına yönelik 5 görevi gerçekleştirmeleri sağlanarak bu süreçteki göz hareketleri incelenmiş son olarak da web sayfasına ait kişisel görüşleri alınmıştır. Katılımcıların %92'si verilen görevleri gerçekleştirirken bunlardan %60,8'lik bir kısım verilen görevleri başarıyla tamamlamıştır. Eğitim düzeyi yüksek olan katılımcıların verilen görevleri daha kısa sürede gerçekleştirdikleri saptanmıştır.

Özçelik ve ark. (2006) göz hareketleri izleme sistemlerinden faydalanarak çeşitli üniversitelerin web sayfalarını incelemişlerdir. Bu çalışma 16 katılımcının değişik üniversite web sayfalarında farklı bilgileri ne kadar sürede, hangi başarı oranında bulduklarını ve bu süreçteki örüntüleri incelemiştir. Veriler ilgili göz hareketlerini izleme cihazı ile toplanmıştır. Çalışma sonunda elde edilen veriler web sayfasında sunulan bilgilerin sunulma şeklinin ve verilen görevlerin katılımcıların davranışlarını etkilediğini ortaya çıkarmıştır.

Uçak ve Çakmak (2009) yaptıkları çalışmada, web sayfalarının tasarımında ve kullanımında hazırlanan sayfaların etkinliğini ölçmek için gerçekleştirilen kullanılabilirlik çalışmalarını incelemişlerdir. Bununla birlikte çalışmalarında, Hacettepe Üniversitesi Bilgi ve Belge Yönetimi Bölümü web sayfasının kullanılabilirliğini ölçmeyi amaçlamışlardır. Farklı bilgi ve beceri düzeyine sahip 7 katılımcı ile gerçekleştirilen çalışmada nitel ve nicel yöntemler bir arada kullanılmıştır. Katılımcıların genel bilgi düzeylerini saptamak için ilk olarak bir ön test uygulaması yapılmıştır. Kullanılabilirlik testinin uygulaması aşamasında katılımcılara web sayfasının farklı bölümlerinin kullanımını gerektiren 14 soru yöneltilmiştir. Soruların yanıtlanması sırasında sesli düşünme tekniği ile elde edilen veriler, tıklama sayıları ve yanıtlama süreleri kaydedilmiştir. Son olarak katılımcılara son test uygulaması yapılarak web sayfası ile ilgili görüşleri alınmıştır. Çalışma bulguları şu şekildedir:

1. Kullanıcıların %71,4'ünün menüleri kısmen yeterli bulunduğunu, %28,6'sının da menülerin yeterli olduğunu ortaya çıkarmıştır. Ayrıca web sitesinin içeriği ile ilgili olarak kullanıcıların %57,1'i web sitesinin kısmen yeterli içeriğe sahip olduğunu ve %42,9'unun ise web sitesinin içeriğinin yeterli olduğunu ifade ettiği görülmektedir.
2. Çalışma, kullanıcıların eğitimleri ile ilgili (dersler, sınavlar, danışmanlar vb. gibi) sayfaların bilgi ihtiyaçlarını ve beklentilerini karşılamaktadır.
3. Kullanıcılar web sayfasının alt yapısından ve hızından memnun oldukları görülmektedir.
4. Bazı linklere ait renklendirme yetersizliği, duyurular kısmında eski ve yeni duyuruların bir arada yer alması, bazı bilgiler için yeterli yönlendirmenin yapılmaması, arama butonunun olmaması ve menü altında yer alan bazı başlıkların mönü başlığı ile çok bağdaşmaması kullanıcılar tarafından dile getirilen şikâyetlerdir.

Durmuş ve Çağıltay (2011) ise yaptıkları çalışma ile Türkiye'deki 33 kamu kurumunun web sitesini içerik analizi yoluyla değerlendirilmiş, sekiz kamu kurumunun da web sitesinin tasarımından sorumlu kişilerle görüşmeler gerçekleştirilmiştir. Değerlendirilen kamu kurumlarının elektronik hizmetleri, kullanılırken karşılaşılan problemler ve bu problemlerin sebepleri belirlenmiştir. Çalışma iki bölüme ayrılmıştır. Birinci bölümde, kullanıcı odaklı tasarım yaklaşımı temel alınarak hazırlanmış, web siteleri değerlendirme aracıyla belirlenen 33 kamu kurumunun web sitesi değerlendirilmiştir. Çalışmanın ikinci aşamasında ise sekiz kamu kurumunun web sitelerinden sorumlu birimleri ile görüşülmüştür. Web sitelerini değerlendirmek için 18 bölüm ve 102 sorudan

oluşan, TÜRKİSAT'ın “Kamu Kurumları İnternet Sitesi Önerileri Rehberi – KAKİS” çalışmasından faydalanılmıştır. Çalışmanın ikinci bölümünü oluşturan kamu kurumlarının web sitelerini hazırlarken kullanıcıya sürece hangi oranla dâhil ettiğini belirlemek için 4 bölüm ve 21 sorudan oluşan bir anket oluşturulmuştur. Çalışma sonuçları tasarımcıların kullanıcı merkezli tasarımla ilgili yaklaşımı kamu web sitesinin performansını etkilediğini ortaya çıkarmıştır. Değerlendirilen 33 kamu kurumu web sitesinin %51'inde içerik örgütlenmesinin problemli olduğu ve bu sitelerinde vatandaşların faydalanacağı hizmetlerin kolay ulaşılabilir yerlerde olmadığı görülmüştür. İncelenen sitelerin %30'unda arama fonksiyonunun olmaması ya da etkin olmaması da kullanıcı açısından sorun teşkil etmektedir. Değerlendirilen birçok sitede gezinim sorunları mevcut olması kullanıcıların hatalı sayfalara yönlenmesine neden olmaktadır. Açılan sayfalarda başlık bilgisinin olmaması kullanıcının web sayfasında kaybolmasına neden olmaktadır. Değerlendirilen web sayfalarının erişilebilirlik sonuçları %60,5 olarak bulunmuştur. Görüşme yapılan yetkililer de bu durumu doğrulamaktadır. Değerlendirme de ortaya çıkan erişilebilirlik sorunları şu şekildedir:

1. W3C öncelik 1 standardına uyulmamaktadır.
2. Uygun yazı büyüklüğü kullanılmamıştır.
3. Alt metin kullanılmamaktadır.
4. Betik ve küçük uygulamalar (applet) ekran okuyucu tarafından okunulamamaktadır.
5. Form kullanımı problemlidir.
6. Geri bildirimler yeterli değildir.

Bir diğer çalışmada, Akıncı ve Çağiltay (2004) 6 e-devlet web sitesinin kullanılabilirliğini değerlendirmişlerdir. Çalışmada katılımcılardan belirli görevleri gerçekleştirmeleri istenmiştir. Bu görevleri gerçekleştirirken yapılan gözlem ve ses kayıtları sonucunda web sayfalarında karşılaşılan temel sorunları; menü tasarımı, bağlantı başlıkları, ana sayfada içerik tasarımı, çalışmayan arama kutuları ve aktif olmayan bağlantıların oluşturduğu bulunmuştur.

SONUÇ ve ÖNERİLER

Yapılan çalışma ile dünyada ve Türkiye’de çevrimiçi öğrenme ortamlarında yapılan çalışmalar ve çalışmalarda uygulanan kullanılabilirlik değerlendirme yöntemleri incelenmiştir. Özellikle Türkiye’de bu alanda yapılan çalışmalara bünyesinde İnsan Bilgisayar Etkileşimi Uygulama ve Araştırma Laboratuvarı’nı barındıran ODTÜ’nün öncülük ettiği görülmektedir. Laboratuvarda bulunan teknik donanım ve yazılımlar bu alanda yapılması düşünülen birçok çalışmada araştırmacılara büyük kolaylıklar sağlamaktadır.

İncelenen çalışmalar, kullanılabilirlik test yaklaşımları ve kullanılabilirlik test türleri olmak üzere iki başlık altında toplanmıştır. Çalışmalar, kullanılabilirlik test yaklaşımları açısından ele alındığında büyük bir kısmının kullanılabilirliğinin kullanıcı testleri ve uzman temelli yaklaşımla değerlendirildiği görülmektedir. Bunun aksine birkaç çalışmada rehber temelli yaklaşım ve model temelli yaklaşıma göre kullanılabilirlik değerlendirmesi yapıldığı görülmektedir. Kullanılabilirlik test türleri açısından ele alındığında ise daha çok süreç sonu testler (Summative/Metrication)’den faydalandığı görülmektedir.

Yapılan inceleme sonucunda, çevrim içi ortamlarda tek bir değerlendirme yöntemi yerine birden fazla değerlendirme yönteminin uygulanmasının ilgili ortamın daha kullanılabilir hale gelmesinde önemli rol oynayacağı düşünülmektedir. Çalışmaların test türü açısından değerlendirilmesinde ise sadece süreç sonu testler değil aynı zamanda süreç içi testlerinde olabildiğince fazla uygulanmasının geliştirilen ürünün kullanılabilirlik faktörünü daha da olumlu seviyelere getireceği düşünülmektedir. Hızla gelişen internet ve web teknolojisinin kullanıcılar için daha kullanılabilir hale gelmesi için yapılan çalışmaların ODTÜ dışında başka kurumlarda da gerçekleştirilmesi bu konuda yeni laboratuvarların kurulmasının bu alanda daha kapsamlı çalışmaların ortaya çıkmasını sağlayacağı düşünülmektedir.

KAYNAKLAR

- Akıncı, D., & Çağiltay, K. (2004). E-devlet Web Sitelerini Kullanmak ya da Kullanmamak: Vatandaş Açısından Kullanılabilirlik Sorunları ve Öneriler, <http://hci.metu.edu.tr/conference/TBD04-edevlet-websiteseleri.doc>. Erişim Tarihi: 29.04.2014
- Alır, G., Soydal, İ., & Öztürk, Ö. (2003). Türkiye’de e-devlet uygulamaları kapsamında kamu kurumlarına ait web sayfalarının değerlendirilmesi.
- Ballard, J. K. (2010). *Web site usability: A case study of student perceptions of educational web sites*. Yayınlanmış Doktora Tezi. Minnesota Üniversitesi.
- Berkman, M. İ. (2006). Türkçe İçerikli Haber Sitelerinde Kullanılabilirlik Değerlendirilmesi ve Analizi. Yayınlanmış Yüksek Lisans Tezi. İstanbul: Bahçeşehir Üniversitesi Fen Bilimleri Enstitüsü

- Bringula, R. P., & Basa, R. S. (2011). Factors Affecting Faculty Web Portal Usability. *Educational Technology & Society*, 14 (4), 253–265.
- Claridge, N., & Kirakowski, J. (2011). Website Analysis and Measurement Inventory questionnaire (WAMMI), <http://www.wammi.com/samples/index.html>. Erişim Tarihi 28.04.2014.
- Çağiltay, K. (2011). İnsan Bilgisayar Etkileşimi ve Kullanılabilirlik Mühendisliği: Teoriden Pratiğe. Ankara: Odtü Yayıncılık.
- Dalcı, M., Alçam, Ö., Saatçioğlu, Y. O., & Erdal, F. (2008). ODTÜ Kütüphanesi yeni web sayfasının tasarımı ve kullanılabilirlik çalışması. *Akademik Bilişim Dergisi* (209-214).
- Davis, F. (1989). Perceived usefulness, perceived ease of use, and user acceptance of information technology. *MIS Quarterly*, 13(3), 319–340.
- Durmuş S., & Çağiltay K. (2011). Kamu Kurumu Web Siteleri ve Kullanılabilirlik, https://www.academia.edu/1961444/KAMU_KURUMU_WEB_SITELERI_VE_KULLANILABILIRLIK. Erişim tarihi: 29.04.2014.
- Eachus, P., & Cassidy, S. (2006). Development of the web users' self-efficacy scale (WUSE) Issues in *Informing Science and Information Technology* 3, 199-209.
- Ersoy, H. (2004). Bir Çevrimiçi Öğrenim Destek Sisteminin Kullanılabilirlik Testi: Planlama, Uygulama, Değerlendirme. *The Turkish Online Journal of Educational Technology–TOJET*.
- Fitts, P. M. (1954). The information capacity of the human motor system in controlling the amplitude of movement. *Journal of experimental psychology*, 47(6), 381.
- George, C. A. (2005). Usability testing and design of a library website: an iterative approach. *OCLC Systems & Services*, 21(3), 167-180.
- Giritli, E. B. (2007). *Web Kullanılabilirlik Analizine İstatistiksel Bir Yaklaşım*. Yayınlanmış Yüksek Lisans Tezi. İstanbul: Işık Üniversitesi.
- Gürses, E. A. (2006). *Kütüphane Web Sitelerinde Kullanılabilirlik ve Kullanıcı Merkezli Tasarım*. Yayınlanmış Doktora Tezi. Ankara: Hacettepe Üniversitesi Sosyal Bilimler Enstitüsü
- Hassan, W. A. W., Teridi, N. A., Abdullah, K. A., Hamid, A., Jusoff, K., & Zainuddin, N. M. M. Z. (2011). Usability of Academic Management System. *Management Science and Engineering*, 5(1), 81-87.
- Hebb, C. L., & Adviser-Frick, T. W. (2005). *Website usability evaluation using sequential analysis*. (Doctoral dissertation, University of Minnesota).
- Ingram, A. L. (2003). Usability of alternative web course structures. *Computers in the Schools*, 19(3-4), 33-47.
- İşbulan, O. (2008). *Uzaktan Eğitim Web Sitesinin Kullanılabilirlik Düzeyi (SAÜ Örneği)*. Yayınlanmış Lisans Tezi. Sakarya: Sakarya Üniversitesi Sosyal Bilimler Enstitüsü
- Işık, A. H., Karakış, R. & Güler, İ. (2011). Gazi Üniversitesi Bilişim Enstitüsü Web Sayfasının Kullanılabilirlik Analizi. In International Conference on New Trends in Education and Their Implications (s. 607-614).
- Jeng, Judy. (2005). Usability Assessment of Academic Digital Libraries: Effectiveness, Efficiency, Satisfaction, and Learnability. School of Communication, Information, and Library Studies, Rutgers, The State University of New Jersey.
- Kamu Kurumları İnternet Siteleri Standartları ve Önerileri Rehberi (2014), <http://www.kakis.gov.tr/kullanilabilirlik>. Erişim Tarihi: 30.04.2014
- Karacan, H., & Demirtel, H. (2009). Türkiye Tüketici Portalının Kullanılabilirliği Üzerine Deneysel Bir Çalışma. *International Journal of Informatics Technologies*, 2(3).
- Karahoca, A., Karahoca, D., & Günoğlu, S. (2009). Web Tabanlı Sınav Otomasyon Sisteminin Kullanılabilirlik Analizi. 4. Ulusal Yazılım Mühendisliği Sempozyumu
- Lee, A. T. (2000). Web site usability, usefulness, and visit frequency. In Proceedings of the Human Factors and Ergonomics Society Annual Meeting (Vol. 44, No. 4, s. 404-407). SAGE Publications.
- Lewis, J. R. (1991). An after-scenario questionnaire for usability studies: psychometric evaluation over three trials. *ACM SIGCHI Bulletin*, 23(4), 79.
- Lund, A. (2001). Measuring usability with the USE questionnaire. *STC Usability*, 8(2).
- NetMechanics Inc., (2007). HTML Toolbox, http://www.netmechanic.com/products/HTML_Toolbox_FreeSample.shtml. Erişim Tarihi: 28.04.2014.

- Nielsen, J. (2012), <http://www.nngroup.com/articles/usability-101-introduction-to-usability>. Erişim Tarihi: 29.04.2014
- Nielsen, J. (2005). Jacob Nielsen's Website: Ten usability heuristics, http://www.useit.com/papers/heuristic/heuristic_list.html. Erişim Tarihi: 29.04.2014
- Nielsen, J. (2005). Ten Usability Heuristics, http://intra.iam.hva.nl/content/1112/verdieping1/research_for_design/intro-en-materiaal/RfD-Heuristic-Evaluation.pdf. Erişim Tarihi: 30.04.2014
- Odtü İnsan Bilgisayar Etkileşimi Araştırma ve Uygulama Laboratuvarı (2014), <http://ibe.bidb.odtu.edu.tr/node/26>. Erişim Tarihi: 29.04.2014
- Öndin, Z. (2007). "Türk Sosyal Güvenlik Kurumlarının Web Sitelerinin Kullanılabilirliği ve Kullanıcı Kabulü." Yayınlanmış Yüksek Lisans Tezi. İstanbul: Boğaziçi Üniversitesi
- Özçelik, E., Kurşun, E., Çağiltay, K. (2006). Göz Hareketlerini İzleme Yöntemiyle Üniversite Web Sayfalarının İncelenmesi. Akademik Bilişim Bildiriler Kitapçığı.
- Rivera, J., Davis, F., Mouloua, M., & Alberti, P. (2010, September). Usability evaluation of two social networking sites. In Proceedings of the Human Factors and Ergonomics Society Annual Meeting (Vol. 54, No. 19, pp. 1421-1424). SAGE Publications.
- Stewart, I., Hong, E., & Strudler, N. (2004). Development and validation of an instrument for student evaluation of the quality of web-based instruction. *American Journal of Distance Education*, 18(3), 131-150.
- TÜRKSAT (2009). Kamu Kurumları İnternet Sitesi Önerileri Rehberi, <http://www.kakis.gov.tr/rehberi-indir>. Erişim tarihi: 25.04.2014.
- Uçak, N. Ö., & Çakmak, T. (2009). Web sayfası kullanılabilirliğinin ölçülmesi: *Hacettepe Üniversitesi Bilgi ve Belge Yönetimi Bölümü web sayfası örneği*. *Türk kütüphaneciliği*, 23(2), 278-298.

PERFORMANS ÖLÇÜMÜNDE KULLANILABİLECEK PROBLEM ÖRNEKLEMELERİ VE ÖĞRENCİLERİN BU PROBLEMLERİ ÇÖZÜM SÜREÇLERİNİN İNCELENMESİ

SAMPLING PROBLEMS CAN BE USED TO PERFORMANCE ASSESSMENT AND EXAMINING STUDENT'S SOLVING PROCESSES OF THESE PROBLEMS

Seval Deniz KILIÇ
Muğla Sıtkı Koçman Üniversitesi
sdenizkilic@mu.edu.tr

Hüseyin ALKAN
Dokuz Eylül Üniversitesi
huseyin.alkan@deu.edu.tr

ÖZET: Birçok araştırmacı bireyin performansı ile bir problemi çözmesi arasında güçlü bir ilişki olduğunu savunmaktadır. Onlara göre performans, “öğrencinin açık uçlu bir problemle karşılaştığında, problemi çözmek için, çeşitli çözümleri denemesi, sentezleme yapması ve ulaştığı sonuçları değerlendirmede ortaya koyduğu etkinlikler bütünüdür”(Shavelson, Baxter and Pine, 1991; Wiggins, 1989; [Slater, 2007](#): s. 7 deki alıntı). Bu anlamı ile, öğrencilerin performans düzeylerinin geliştirilmesi, onların okulda sıra dışı problem çözme becerilerinin gelişim düzeyinin ve dolayısıyla gerçek hayattaki başarılarının arttırılmasına denk olarak alınabilir. Bu çalışmada, performans ölçümünde kullanılmak üzere çok sayıda rutin olmayan (sıra dışı) problem incelenmiş ve uzman görüşü alındıktan sonra ölçme aracında kullanılmak üzere seçilmiştir. Seçilen problemler oluşturulan rubrike (derecelendirmeli puanlama anahtarı) uygun olarak çözülmüştür. Daha sonra bu problemlerden oluşan ölçme aracı, İzmir İli'nde yer alan bir devlet anadolu lisesinin 9. sınıfına devam eden 29 öğrenciye uygulanmıştır. Elde edilen bulgular öğrencilerin performans düzeylerinin oldukça düşük olduğunu göstermektedir.

Anahtar sözcükler: performans ölçümü, rutin olmayan matematik problemleri.

ABSTRACT: Many researchers advocate that there is a strong relation between individual performance and solving a problem. According to them, when student encounters an open ended problem, to solve a problem, attempts various problem solving approaches, synthesizes and evaluates reached findings. All these activities are named as a performance (Shavelson, Baxter and Pine, 1991; Wiggins, 1989; as cited in [Slater, 2007](#): p. 7). In this sense, improvement of students' performance level, equivalently admissible as their non-routine problem solving ability improvement level and so advancement of real life achievement. In this study, to assess performance, lots of non routine problems were examined and selected after expert opinion. Then selected problems were solved according to created rubric. Subsequently, assessment tool which consisting of these problems, applied 29 high school students attending 9th grade in an [anatolian high school](#) in İzmir. Acquired findings show that students performance level is very low.

Key words: performance assessment, non- routine math problems.

GİRİŞ

Eğitim sistemlerinin ana hedeflerinden biri bireylerin “*yalnızca okul testinden başarılı olmasını değil yaşamda başarılı olmasını sağlamaktır*”(Alkan,2008). Okuldaki akademik başarı, edinilen kazanım ve beceriler, yaşamdaki olası başarının bir hazırlık dönemi ve geleceğe dönük bir gösterge olarak düşünülmelidir. Kısaca bireylerin çalışma alanlarında başarılı olması doğrudan doğruya, aldığı eğitimin düzey ve niteliğine, edindiği kazanımlara ve geliştirdiği değişik yönlü becerilerine bağlıdır. Aynı zamanda bireysel başarı, tüm bu kazanım ve edinimlerin uygulamaya dönüştürülmesi, yerinde kullanabilmesi ile de ilgilidir. Daha açık söylemek gerekirse, iş yaşamında başarılı olmak, karşılaşılan bir problem ya da çıkmaz durumunda bireyin edinimlerini doğru kullanmasını, kuramsal bağlantıları doğru kurmasını ve uygun sonuçlara ulaşmasını gerektirmektedir. Sıralananlar çalışma alanı ne olursa olsun, herkes için geçerlidir ve sıradandır. Ancak unutulmamalıdır ki en iyi, en yararlı ve en çekici olan sonuca ulaşmak, sıradan davranışların dışında bireysel farklılıkları da gerektirir. Başka bir deyişle bu noktada bireysel performans düzeyi işin içine girer.

Günümüz insanında değişik nitelik ve becerilerin birlikte bulunmasından söz edilmektedir. Bunların başında örneğin; “Problem çözme için bilgi toplama ve düzenleme becerisi”, “araştırma yapma ve yönetme becerisi”, “verileri analizleme ve sentezleme becerisi”, “bilgiyi yeni durumlara uygulama ve uyarlama becerisi”, “bireyin kendi öğrenme ve performansını izleme ve geliştirme becerisi”, “değişik biçimlerde iyi iletişim kurma becerisi”, “birlikte çalışabilme ve bağımsız öğrenebilme becerisi” gelmektedir (Darling-Hammond, L.&McCloskey, L.; 2008). Belki bu nedenle ve tüm işsizliğe karşın, gerek Türkiye’de, gerekse diğer dünya devletlerinde nitelikli insan ve iş gücü açığı kapatılamamaktadır. Arzulanan hem planlı eğitim sürecinde hem de meslek içi eğitim süreci boyunca, bireylerin her yönü ile verimli kimseler konumuna gelebilmesi ve gözlenen açığın kapatılabilmesidir. Kuşkusuz bu beklentiler kısa sürede gerçekleştirilecek yapıda değildir. Ancak uzun soluklu bilinçli ve planlı bir çalışma süreci sonunda bu alanlarda başarı sağlanabilir. Vurgulandığı gibi bu sürecin en önemli ayağı planlı öğretimdir. Daha da özelleştirilerek planlı zorunlu eğitim sürecidir. Çünkü bireylerin temel davranış ve becerileri esas bu süreçte şekillenmektedir. Bunun doğal bir sonucu olarak, günlük yaşamdaki bireysel başarı ortaya çıkmaktadır.

Özetlersek birey, eğitimi sürecinde ve meslek içi eğitimi boyunca, belli kazanım ve becerileri edinmeli ve yaşamında bunları en iyi biçimde kullanabilmelidir. Öyleyse öğrencinin eğitim sürecinde sıralanan niteliklerin tümünü ve doğru biçimde edindiğinden emin olmak gerekir. Edinimlerin göstergeleri ölçme ile ortaya konduğuna göre, eğitim süreci boyunca ölçmenin olabildiği ölçüde eksiksiz yapılması gerekir. Yani ölçme ve değerlendirmenin en az hata ile gerçekleştirilmesi zorunluluk gösterir.

Eğer okuldaki ölçme, bireyin yaşamındaki olası başarısından bağımsız gibi algılanır ya da “okul testinden başarı” akademik başarı için yeterli görülürse, korkudur ki yaşamda başarısızlık kaçınılmaz olabilir. Bu konuda, vurgulanması destekleyici birçok çalışmaya rastlanmaktadır. Örnek olarak Baker’ın çalışması alınabilir. *“Öğrencilerin okulda edindiği bilginin düzeyi ve türü sıkça tartışılmaktadır. Yapılan ulusal ve uluslar arası çalışmalar, öğrencilerin bilgi ve beceri düzeylerinin düşük olduğunu göstermektedir. Dahası, öğrencilerin iş dünyası için yeterince iyi olmadığı görüşü Amerikan iş ve sanayi hayatında daha sık tartışılır duruma gelmiştir. Bu endişeler nedeniyle, aşağı yukarı on yıldır, öğrencilere ne öğretildiği ve öğrenme düzeylerinin nasıl ölçüldüğü konusunun yeniden yapılandırılması için çaba harcanmaktadır”* (U.S Department of Labor, 1991, 1992; Baker, L., 1997: s. 1 deki alıntı).

Amerika Birleşik Devletleri’nde yapılan bu çalışma ve geliştirilen öneriler ülkemiz için de geçerli gibi görünmektedir. Ölçme aracı olarak değişik test türlerinden yararlanmayı gelenek haline getirmiş eğitim sistemimiz ile yetiştirilen öğrenciler, gerçek anlamda kapalı ya da açık uçlu bir problemi çözmeden zorunlu eğitimlerini tamamlamaktadırlar. Aynı biçimde lise eğitimleri boyunca üniversiteye giriş sınavlarına odaklanarak dört yıllarını geçirmektedirler. Dolayısı ile “çoktan seçmeli”, “doldurmalı” gibi test soruları dışındaki sorular ile karşılaştıklarında sıkıntıya düşmektedirler. Oysa örneğin PISA matematik soruları öğrencilerin, gerçek yaşam ile ilgili matematiksel problemlerle yüzleşmesini gerektirmektedir. Öğrenciyi araştırma yapmaya zorlamaktadır. Bu tür problemleri çözmek için matematiksel düşünme ve belli becerileri harekete geçirmek şarttır. Çünkü öğrenci gerçek bir problemle karşılaştığında, çözüm sürecini planlayabilmelidir. Bunun için gerekli matematiksel ön öğrenmeleri belirlemeli ve ardından problemi gerçek hayat durumundan ayırarak, varsayımlarda bulunarak ve genelleme yaparak bilgiyi biçimlendirmelidir. Daha sonra değişik yolları deneyerek, problemin dili ve matematiksel dil arasındaki ilişkiyi görmeli, uygun düzen ve modelleri aramalı, bilinen yol-yöntemden de yararlanarak problemi matematiksel modellemelidir. En son oluşturduğu modelin matematiksel yapısını çözülebilirlik koşullarını belirleyerek, çözüme yakın hale getirmelidir (Programme for International Student Assessment, 2004: 40). Görüldüğü gibi burada önerilen ölçme sorusu ve süreci ile bizim testten yararlanarak yaptığımız ölçme arasında ortak nokta hemen hemen yok gibidir. Yani bu ölçme türü bizim öğrencilerimize çok yabancıdır.

Marzano ve arkadaşları, ölçme ile ilgili yaptıkları bir çalışmada, bin dokuz yüz seksenli yıllarda, eğitimde ölçme alanında önemli değişimlere gerek duyulduğunu ortaya çıkarmışlardır (Archbald and Newmann 1988, Shepard, 1989; Marzano vd., 1993:s.9’deki alıntı). Bu çalışmaların oluşturduğu değişim tabanında ölçmenin yalnız geniş ölçekteki standardize testlerle yapılamayacağı vurgulanmaktadır. Ölçmenin, eğitim süreci boyunca ve her düzeyde yapılması gerektiği netleştirilmektedir.

Amerika Birleşik Devletleri’nde 1970’lerde başlayan eğitimde reform hareketi, öğrencilerin bilgilerini kullanmaları ve yeterlilik testlerinden başarılı olmalarının önemini vurgulamıştı. Oysa 1990’larda başlayan yeni eğitimde reform hareketi daha gelişmiş eğitim hedeflerine ve daha yüksek standartlara odaklandı. Ülkenin eğitim hedefi, Amerika Birleşik Devletleri’ni, 2000’li yıllarda dünyada en iyi konumlardan birine ulaştırmaktı (Bush, 1991; Marzano vd., 1993:s.9 daki alıntı). Bunun için eğitimde ölçme sisteminin değişmesi gerektiği öne çıktı. Çalışmalarda daha somutlaşmalara gidilerek öğrenci kazanımlarının net olarak ortaya konabildiği, performans ölçümüne geçilmesi gerektiğine vurgu yapıldı. ABD’de düzenlenen “Ulusal Eğitim Hedefleri Panelinde “(1991), yetkililer ulusal ve eyaletler düzeyinde öğrencilerin hedefe yönelik başarılarını izlemekle yükümlü kılındı. Derlenecek sonuçlara göre öğrenci gelişiminin belirlenebilmesi için öğrenme standartlarının ortaya konması istendi. Aynı zamanda tam öğrenmenin göstergeleri sayılan, tüm alanı kapsayan derin alan

bilgisi, problem çözme becerisi ve bu yeterliliklerin nasıl ölçüleceğini ortaya koyan ölçme araçlarının belirlenmesi gereği netleştirildi(Niemi, 1997:247). Tüm bu sonuç ve yaklaşımlar, eğitimin istenen hedeflere ulaşılabilmesi ve bu süreçte öğrenci gelişiminin gözlenebilmesi için, öğrencinin akademik performans ölçümünün gerekliliğini netleştirdi.

Birçok araştırmacı bireyin performansı ile karşılaştığı problemi çözmesi arasında birebir ilişki olduğunu savunmaktadır. Onlara göre performans, “öğrencinin açık uçlu bir problemle karşılaştığında, problemi çözmek için, çeşitli çözme yaklaşımları denemesi, sentezleme yapması ve ulaştığı sonuçları değerlendirmede ortaya koyduğu etkinlikler bütünüdür”(Shavelson, Baxter and Pine, 1991; Wiggins, 1989; Slater, 2007: s. 7 deki alıntı). Benzer bir yaklaşımda, öğrencilerin çözümü gereken bir problemin yanıtlarını kendilerinin oluşturmaları ya da bilgi ve becerilerini sergileyerek ürün ortaya koymaları, performansları ile açıklanabilir denmektedir (OTA, 1992. 16; Elliott, 1997:s. 5’deki alıntı). Bu yaklaşımlarda bilinen problem çözme basamaklarının kullanımı yanında, strateji belirleme, modelleme ve muhakeme gibi bireysel farklılıkları öne çıkaran nitelikler de vurgulanmaktadır.

Yapılan çalışmalar salt bir ürüne ya da düşünceye odaklanmamaktadır. Tersine ürün ya da düşüncenin ortaya konması, oluşum sürecinin açıklanması ve gerektiğinde savunulması da söz konusudur. Burada olay, olgu ya da karşılaşılan bir problemin algılanmasından başlayan ve yeni bir sonuca giden her aşamanın açıklanması dile getirilmektedir. Aslında kavramları açıklama ve sürecin her basamağını doğrulama becerisi, bireyin alan bilgisinin ayrılmaz bir parçası olarak tanımlanmaktadır (American Association for the Advancement of Science, 1993; NCTM, 1989; Niemi, 1997:s. 243’deki alıntı).

Performans ölçümünde kullanılabilecek problemler sıradan(rutin) olmayan problemlerdir. Çünkü bu tür ve “Açık uçlu problemlerin” çözümü, birden çok doğru cevabı içerebilir ve öğrencinin çözüm için çok yönlü yaklaşımlar denemesine fırsat sağlar” (Hancock,1995; Chan, 2007:s.2’deki alıntı). Açık uçlu problemler ise Foong’a (2002) göre hastalıklı yapıya (ill-structured) sahiptirler. Çözümlerini garantileyen belli bir çözüm yöntemi yoktur ve bireysel varsayımlar içerirler (Foong, 2002; Chan, 2007: s.2’deki alıntı). Buna karşılık “Öğretmene, öğrencilerinin problem çözme sürecini nasıl gerçekleştirdiği konusunda anlamlı bilgi sağlarlar” (Van den Heuvel-Panhuizen, 1996; Chan, 2007: s.2’deki alıntı). Özet olarak sıradan olmayan ve açık uçlu problemlerin çözüm süreci ile bireysel performans ölçümü arasında yakın ilişki vardır.

Günümüzde bilgiye ulaşmak teknolojinin de gelişimi ile daha kolay bir hale gelmiştir. Önemli olan bireyin bilgisini nasıl kullandığıdır. Bilgisini doğru kullanan ve değişik şeyler üretenler öne çıkmaktadır. Yani, “bireysel farklılıklar” önem kazanmaktadır. Aynı problemi daha kısa sürede, daha az emekle ve daha ekonomik çözenler aranmaktadır. Bu nedenle ana amaç üst düzey verimlilik olarak ortaya konmaktadır. Bireyin verimli, okul ve gündelik yaşamda başarılı olmasının değişmez koşulu ise kendine güven duymasıdır. Beklenen, kendine güvenen kimsenin karşılaştığı problemleri de çözebileceği yönündedir. Öte yandan bir problemin çözümüne etkin olarak katkıda bulunmak öğrenciyi üst düzey düşünme ve üretkenlik konusunda yüreklendirir (Dyer & Moynihan, 2000). Bu yönü ile problem çözerek performans ölçümü bireye öz güven kazandırır. Bireysel farklılıkları öne çıkarma amaçlı performans ölçümünde, “ üst düzeyde bilişsel kapsam, iletişim, gerçek yaşam uygulamaları” aranır. Buna ek olarak eğitimde, “ öğrencinin kullandığı zaman ile harcadığı çaba arasındaki ilişkiler ve öğretmenin not verme sürecinde doğru karar vermesi” önemli sayılır(Palm, 2008).

Performans ölçümünde önemli olan, ölçme araçları ile performans bileşenlerinin doğru ilişkilendirilmesidir. Performans değişkenlerine en uygun ölçme aracı problemler olarak görülmektedir. Problem çözme sürecinde yer alan basamaklar, öğrencinin performansını açığa çıkarmada ideale yakın ödev üstlenirler. Özellikle problem geliştirme de ölçmeye katıldığında, tüm performans bileşenleri ile problem çözme adımları kolayca ilişkilendirilebilmektedir.

Problem çözüm basamakları doğru düzenlenir ve her basamaktaki öğrenci davranışları net tanımlanabilirse, performans ile problem çözme ilişkisi kolayca kurulabilir. Bu amaçla Marzano’nun (1993) önerdiği dört adımlı derecelendirmeli puanlama anahtarı (rubrik) kullanılabilir(bkz. Şekil 1).

Şekil 1: Problem Çözme İçin Dereceli Puanlama Anahtarı (Rubrik)

puan	Problemi anlama, sınırlılık ve zorluklarını belirleme .
4	Problemin ana yapısını ve sınırlamalarını tam olarak tanımlar ve açık olmayan sınırlılıkları da gösterir.
3	Problemin ana yapısını ve sınırlılıklarını tam olarak tanımlar.
2	Problemin birtakım yanını ve sınırlamalarını eksik tanımlar.
1	Problemin birçok yanını ve sınırlamalarını ortaya koyamaz.
Problemi çözebilmek için uygulanabilir ve tutarlı çözüm yolları sunma.	
4	Tartışılmakta olan problem için, yaratıcı ve kullanılabilir çözümler tanımlar. Çözümler kritik noktaları hedef alır.

3	Problemin ana kritik noktalarını içeren farklı çözüm yolları sunar.
2	Problemin bazı kritik noktalarını içeren çözüm yolları sunar.
1	Problemin kritik bölümlerini içermeyen çözüm yolları sunar.
Çözüm yollarını seçme ve yeterli miktarda deneme yapma.	
4	Seçtiği alternatif çözümleri; etkin, geçerli ve ayrıntılı biçimde dener. Kullandığı problem çözme denemeleri ile problem çözme bilgisi arasında tam bir bağlantı kurar.
3	Seçtiği alternatif çözümlerin doğru ve yararlı olduğunu ortaya koyar.
2	Tam sonuç getirmeyen çözüm yolları dener ve bu problemin bazı elemanlarını ya hiç kullanmaz ya da eksik kullanır.
1	Başarılı olmayan çözüm yolları seçmiştir.
Farklı çözüm yolları denendiğinde, neden o çözümlerin seçildiğini açıklama ve tartışma. Hangi yaklaşımın daha kapsamlı ve yararlı olduğunu ortaya koyma.	
4	İkincil çözümlerin seçimlerine yol açan muhakemenin geniş kapsamlı, net bir özetini sunar. Bu özet, seçilecek alternatifleri ve hangi alternatifin çözüm olarak kabul edileceğini gösteren kararları içerir.
3	İkincil çözümlerin yapısını tanımlar. Bu tanım farklı çözümlerin yapısını açık ve net biçimde ortaya koyan kesin seçimdir.
2	İkincil çözümlerin yapısını tanımlar. Fakat bu tanımlama ikincil çözümlerin gerçek yapısını ortaya koyamaz.
1	Farklı çözüm yollarının birbirlerine göre önemini belirlemede mantıklı yöntemler tanımlayamaz. Öğrenci denenmiş ve vazgeçilmiş alternatif çözümlerin eksik ve güçlü taraflarını sergileyen mantıklı bir açıklama sunamaz.

Bir anlamıyla önceden verilen tanımların tümünü içeren yaklaşım Baker tarafından şöyle özetlenmektedir. Performans, “öğrencilerin hedeflere yoğunlaşmaları, ön öğrenmelerini ve edindikleri yol-yöntem becerilerini kullanarak problem çözmeleri, gördüklerini ya da ulaştıkları sonucu analiz edebilmeleri ve başkaları ile paylaşabilmeleri demektir” (Baker,1997:248).

Görüldüğü gibi rubriğin ilk adımında öğrencinin, problemi doğru anlaması, problemin sınırlarını, açık ve kapalı taraflarını, zorluklarını görmesi istenmektedir. Bu durum öğrencinin, konu ya da kavrama ilişkin edinmiş olması gereken ön öğrenmelerini ne ölçüde içselleştirdiği ile ilintilidir. Başka bir deyişle ilk basamakta başarılı olma, olay, olgu ya da problemi doğru anlama ve belli düzeyde ön bilgiye sahip olmayı gerektirmektedir.

Rubriğin ikinci adımında, öğrencinin problemi çözebilmek için kritik noktaları hedef alan yaratıcı ve kullanılabilir çözüm yolları ortaya koyması istenmektedir. Bu bir yandan akıl yürütmeyi öte yandan da matematiksel bir model oluşturmayı gerektirmektedir. Çünkü öğrenci model oluşturarak, problemin kritik noktalarına vurgu yapar. Bağlantı kurarken gösterdiği yaklaşımlar da kullandığı stratejilere kanıt olur. Buna göre, öğrencinin, ikinci adımda başarılı olabilmesi, muhakeme yapabilme ve strateji geliştirebilme becerisi ile ilişkili olur.

Rubriğin üçüncü adımında, öğrencinin seçtiği alternatif çözümleri, etkin, geçerli ve ayrıntılı biçimde denemesi istenir. Deneme sonucu elde ettiği sonuçların koşullara uygun olup olmadığını değerlendirmesi ve karşılaştırması beklenir.

Dördüncü adım bireyselliğin daha çok öne çıktığı adımdır. Burada öğrenciden çözümü tartışması ve neden o çözüm ya da çözümleri seçtiğini açıklaması beklenmektedir. Buna ek olarak ulaştığı sonuçlardan çıkarımlarda bulunması istenir. Ulaştığı çıkarımlar ile problemi genişletme ve geliştirme çabaları sergilemesi arzulanır. Bu yolla, problemi günlük yaşamla ya da başka alanlar ile ilişkilendirme yolları açılabilir. Kısaca öğrencinin en azından, “eğer ...olsaydı” gibi sorulara cevap arayarak çözdüğü bu problemi genişletmesi gerekir. Çıkarımda bulunma özünde, yaptıklarını açıklayabilme, yapılanları yaşama aktarabilme, bireysel yeteneklerini kullanabilme ve kendine güvenme bileşenleri ile ilişkili görülür.

Aşağıda, rubriğe uygun olarak çözülmüş bir problem örnekleme yer almaktadır.

Problem: Aşağıda eşit uzunlukta çubuklarla oluşturulmuş sekizgen dizileri verilmiştir. Bu diziler bu şekilde devam ederse, 120. dizide kaç tane çubuk kullanılır?

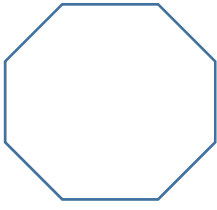

1. dizi

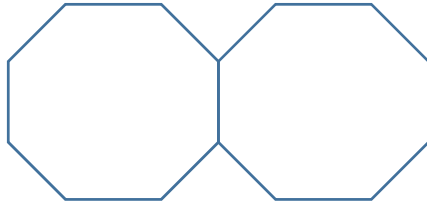

2. dizi

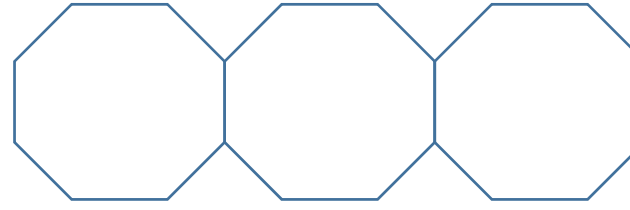

3. dizi

Eş çubuklardan biri: —

Rubrik

puan	
4	1 - Anlama Adımı
	Verilen: Sekizgen dizileri verilmiş. Birinci dizide 1 sekizgen, ikinci dizide 2 sekizgen olmak üzere, kaçınıcı dizi yapılıyorsa o kadar sekizgen kullanılmış.
	İstenen: Bu şekilde diziler yapılmaya devam edilirse, 120. dizide kaç çubuk kullanıldığı soruluyor.
	Koşul: Birden fazla sekizgen yapılmışsa, yapışık sekizgenler için bir çubuk ortak kullanılıyor. Sınırlılık: kullanılan çubukların uzunlukları eşittir. Yani problem düzgün sekizgenlerle sınırlıdır. Sorunun Açık Tarafı: Verilen dizide kaç tane sekizgen bulunduğu bilinmektedir. Sorunun Kapalı Tarafı: 120. terimde kaç tane sekizgen ve kaç tane çubuk olduğu bilinmiyor. Bunun için bir model bulunmalıdır.
3	Verilen: Sekizgen dizileri verilmiş. Birinci dizide 1 sekizgen, ikinci dizide 2 sekizgen olmak üzere, kaçınıcı dizi yapılıyorsa o kadar sekizgen kullanılmış.
	İstenen: Bu şekilde diziler yapılmaya devam edilirse, 120. dizide kaç çubuk kullanıldığı soruluyor.
	Koşul: Birden fazla sekizgen yapılmışsa, yapışık sekizgenler için bir çubuk ortak kullanılıyor. Sınırlılık: kullanılan çubukların uzunlukları eşittir. Yani problem düzgün sekizgenlerle sınırlıdır.
3	Verilen: Sekizgen dizileri verilmiş. Birinci dizide 1 sekizgen, ikinci dizide 2 sekizgen olmak üzere, kaçınıcı dizi yapılıyorsa o kadar sekizgen kullanılmış.
	İstenen: Bu şekilde diziler yapılmaya devam edilirse, 120. dizide kaç çubuk kullanıldığı soruluyor.
	Sorunun Açık Tarafı: Her dizide kaç tane sekizgen bulunduğu bellidir. Sorunun Kapalı Tarafı: 120. dizide kaç tane sekizgen olduğu bilinmiyor. Bunun için bir model bulunmalıdır.
2	Verilen: Sekizgen dizileri verilmiş. Birinci dizide 1 sekizgen, ikinci dizide 2 sekizgen olmak üzere, kaçınıcı dizi yapılıyorsa o kadar sekizgen kullanılmış.
	İstenen: Bu şekilde diziler yapılmaya devam edilirse, 120. dizide kaç çubuk kullanıldığı soruluyor.
	Koşul: Birden fazla sekizgen yapılmışsa, yapışık sekizgenler için bir çubuk ortak kullanılıyor.

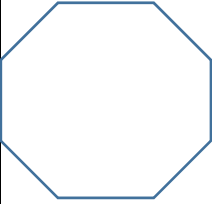
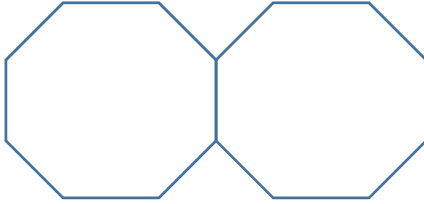
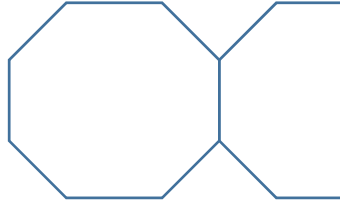

2	<p>Verilen: Sekizgen dizileri verilmiş. Birinci dizide 1 sekizgen, ikinci dizide 2 sekizgen olmak üzere, kaçınıcı dizi yapılıyorsa o kadar sekizgen kullanılmış.</p> <p>İstenen: Bu şekilde diziler yapılmaya devam edilirse, 120. dizide kaç çubuk kullanıldığı soruluyor.</p> <p>Sınırlılık: Kullanılan çubukların uzunlukları eşittir. Yani problem düzgün sekizgenlerle sınırlıdır.</p>
2	<p>Verilen: Sekizgen dizileri verilmiş. Birinci dizide 1 sekizgen, ikinci dizide 2 sekizgen olmak üzere, kaçınıcı dizi yapılıyorsa o kadar sekizgen kullanılmış.</p> <p>İstenen: Bu şekilde diziler yapılmaya devam edilirse, 120. dizide kaç çubuk kullanıldığı soruluyor.</p> <p>Sorunun Açık Tarafı: Her dizide kaç tane sekizgen bulunduğu bellidir.</p>
2	<p>Verilen: Sekizgen dizileri verilmiş. Birinci dizide 1 sekizgen, ikinci dizide 2 sekizgen olmak üzere, kaçınıcı dizi yapılıyorsa o kadar sekizgen kullanılmış.</p> <p>İstenen: Bu şekilde diziler yapılmaya devam edilirse, 120. dizide kaç çubuk kullanıldığı soruluyor.</p> <p>Sorunun Kapalı Tarafı: 120. dizide kaç tane sekizgen olduğu bilinmiyor. Bunun için bir model bulunmalıdır.</p>
1	<p>Verilen: Sekizgen dizileri verilmiş. Birinci dizide 1 sekizgen, ikinci dizide 2 sekizgen olmak üzere, kaçınıcı dizi yapılıyorsa o kadar sekizgen kullanılmış.</p> <p>İstenen: Bu şekilde diziler yapılmaya devam edilirse, 120. dizide kaç çubuk kullanıldığı soruluyor.</p>

puan	2 – Bağlantıların Kurulması Adımı		
4	 <p>1. dizi</p> <p>8 çubuk</p> <p>$7 \cdot \underline{1} + 1$</p>	 <p>2. dizi</p> <p>15 çubuk</p> <p>$7 \cdot \underline{2} + 1$</p>	 <p>3. dizi</p> <p>22 çubuk</p> <p>$7 \cdot \underline{3} + 1$</p>
	Buna göre,		

	n terimli dizi için $7.n+1$ tane çubuk kullanılmalıdır.
3	Bağlantıda az eksiklikler vardır. Bağlantı tam kurulamaz.
2	Denemeler yapılır fakat bağlantı tam değildir.
1	Yaklaşım doğru değildir.

puan	
	3 – Uygulama Adımı
4	120. dizi istendiğine göre, $7.n+1$ için $n=120$ verelim. $7.120+1=840+1=841$ çubuk gereklidir.
3	Model bulunamaz, çubuklar tek tek sayılmaya çalışılır, 841'e bu şekilde ulaşılır.
2	Çubukları tek tek saymayı dener fakat tamamlayamaz.
1	İlk birkaç sekizgen için çubukları sayar.

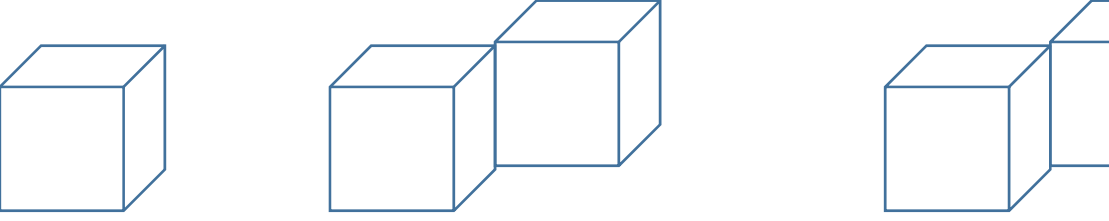
puan	
	4 – Çıkarımlar ve Geliştirme Adımı
4	Çıkarımlar: 1- Doğru yerleştirme ile, az sayıda materyal kullanarak çok sayıda geometrik şekil elde edilebilir. 2- Sayı dizilerinin arasındaki ilişkiler araştırılarak, bu dizilerle ilgili bir kural bulunabilir. Geliştirme: 1- Eşit uzunlukta kibrit çöpleri ile oluşturulmuş küp dizileri verilmiştir. Bu dizinin ilk üç terimi aşağıdaki gibidir. Buna göre, 100. dizide kaç kibrit çöpü kullanılır?

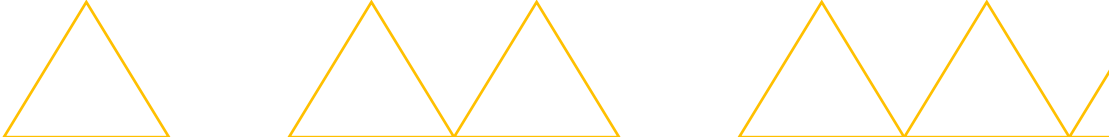
	 <p>2- En az kibrit çöpü kullanmak ama yine yukarıdaki sayıda küp elde etmek isterseniz yukarıdaki küpleri sıralamak için nasıl bir yöntem bulabilirsiniz? Açıklayınız.</p>
3	<p>Çıkarım:</p> <ol style="list-style-type: none"> 1- Sekizgenlerin farklı yerleşimleri ile, tüm sekizgenlerin kenar sayısından az çubuk kullanılarak çok sayıda sekizgen elde edilebilir. 2- Sekizgen dizileri arasındaki ilişkiler araştırılarak, 120. Dizide kaç çubuk olduğu bulunabilir. <p>Geliştirme:</p> <ol style="list-style-type: none"> 1- Eşit uzunlukta kibrit çöpleri ile oluşturulmuş altıgen dizileri verilmiştir. Bu dizinin ilk üç terimi aşağıdaki gibidir. Buna göre, 100. dizide kaç kibrit çöpü kullanılır?  <p>...</p> <ol style="list-style-type: none"> 2- Altı tane eş uzunlukta çubuktan oluşan 7 tane düzgün altıgeni öyle bir yerleştiriniz ki, kullandığınız çubuk sayısı en az olsun.
2	<p>Çıkarım: Sekizgenlerin uygun yerleştirilmesi ile, tüm sekizgenlerin kenar sayısından az çubuk kullanılarak çok sayıda sekizgen elde edilebilir.</p> <p>Geliştirme: Üç adet eş çubuk ile oluşturulan 6 tane eşkenar üçgeni öyle bir yerleştiriniz ki, kullanılan çubuk sayısı en az olsun.</p>
2	<p>Çıkarım: Sekizgen dizileri arasındaki ilişkiler araştırılarak, 120. Dizide kaç çubuk olduğu bulunabilir.</p> <p>Geliştirme: Eşit uzunlukta çubuklar ile oluşturulmuş kare dizileri verilmiştir. Bu dizinin ilk üç terimi aşağıdaki gibidir. Buna göre, 120. dizide kaç çubuk kullanılır?</p>  <p>...</p>

1	Çıkarım: Sekizgenlerin farklı yerleşimleri ile, tüm sekizgenlerin kenar sayısından az çubuk kullanılarak çok sayıda sekizgen elde edilebilir.
1	Çıkarım: Sekizgen dizileri arasındaki ilişkiler araştırılarak, 120. Dizide kaç çubuk olduğu bulunabilir.

Performans, öğrencinin bireysel farklılığını ortaya çıkarır ve bu yönüyle çok önemlidir. Eğitim psikolojisinde yapılmış bir araştırmaya göre, öğrenci geliştirilmiş çözüm yollarından birini seçmek yerine, kendi çözümünü kendisi sağladığında daha iyi öğrenir (Mayer, 1996; Baker, 1997'deki alıntı). Bu nedenle, öğrenci başarıları önceden hazırlanmış çoktan seçmeli testlerle değil, onu tamamen özgür bırakan problem çözme davranışlarıyla ölçülmelidir. Burada öğrencinin, kritik noktaları öne çıkarması ve yol-yöntem seçim becerileri gözlenebilir. Süreç boyunca öğrencinin yaratıcılığı desteklenebilir, öğrenci kalıpların dışına çıkmaya ve risk almaya yöreklendirilebilir. Dolayısıyla kendine olan güveni artırılarak performans gelişimine katkı sağlanabilir. Gerçekte, “akademik alanda kendini yetersiz hissedenden ve okul ortamında kontrol edildiğini ve engellendiğini düşünen öğrencinin akademik motivasyonu azalır ve sonunda okul performansı da düşer” (Fortier ve diğerleri, 1995). Bunun engellenmesi gerekir. Bu yönü ile yaklaşıldığında, sınıfta yapılan etkinlikler öğrencinin bireysel yeteneklerini geliştirmek için fırsatlar sunabilir. Birlikte çalışmada gerçekleştirilen tartışma, akıl yürütme gibi beceriler birer örnek olarak düşünülebilir. Bu noktada öğretmenin öğrencilerine vereceği araştırma ödevleri önemli rol üstlenebilir. Bu süreçte öğrencilerden, kaynaklarda verilenleri aynen kullanma yerine, “kendilerinden bir şeyler katmaları” istenebilir. Öğretmen özellikle birlikte çalışmalarda, her öğrencinin aktif olmasını isteyerek ilk adımını atabilir. Gerçekten grup çalışmaları öğrencilerin kendi stratejilerini oluşturmaları için bir avantaj olabilir. Çünkü burada öğrenci verilen bir problemle uğraşırken, arkadaşlarının problem çözme sürecine de şahitlik edecektir. Bu durum öğrenciye yeni ufuklar açar, kendi stratejisini oluşturmaya yardımcı olur.

YÖNTEM

9. sınıf öğrencilerinin performans gelişim sürecini ortaya çıkarmayı amaçlayan daha büyük bir araştırmanın bir parçası olan bu çalışma, öncelikle rutin olmayan problemlerin seçimini ve sonrasında da öğrencilerin oluşturulan rubriklere göre bu problemleri çözüm süreçlerini ortaya koymayı hedeflemiştir. Çalışmada nicel ve nitel araştırma teknikleri birlikte kullanılmıştır.

Katılımcılar

Çalışmanın katılımcıları, 2010-2011 eğitim-öğretim yılında İzmir İli sınırları içerisinde bulunan bir devlet Anadolu lisesinin 9. sınıfına devam eden 14'ü kız, 15'i erkek 29 adet öğrencidir. Uygulamayı yapabilmek için Milli Eğitim Bakanlığı'ndan izin alınmıştır. Uygulama Anadolu lisesinde gerçekleştirildiği için seçilen öğrenciler, bakanlığın yaptığı SBS sınavı not ortalamalarına göre alınmıştır ve biri birine oldukça yakın düzeydedirler. Yani kayıta kullanılan puan aralığı dar bir genlikte salınım göstermektedir. Okula kayıt yaptıran öğrencilerin aileleri de biri birine yakın sosyo-ekonomik düzeye sahiptir.

Uygulama Öncesi Yapılan Çalışmalar

Deney çalışmasına başlamadan önce ilk iş olarak, öğrencilerin 6. 7. ve 8. sınıfta girmiş oldukları seviye belirleme sınavına ait bilgileri derlenmiştir. Her öğrencinin bu sınavlardan kaç puan aldığı ve sınavların matematik bölümünde kaç doğru yanıt olduğu belirlenmiştir. Bunlara ek olarak öğrencilerin 8. sınıftaki matematik dersi sene sonu not ortalamaları çizelgelenmiştir. Okul idaresinden sınıfların, her sınıfa her düzeyden öğrenci olacak biçim düzenleme yapıldığı derlenen bilgilere eklenmiştir. Uygulama bir Anadolu lisesinde gerçekleştirildiği için öğrencilerin liseye giriş puan aralığı dar genlikli olduğu gözlenmiş ve bu nedenle düzeyleri arasında aşırı fark olmaması beklentisine girilmiştir. İkinci aşamada, ön öğrenmelerini yoklamak ve olası eksiklerini belirlemek amacıyla, tüm öğrencilere düzey belirleme sınavı (DBS) uygulanmıştır. Geliştirilen bu sınavın soruları, Milli Eğitim Bakanlığı'nın 7. ve 8. sınıflar için gerçekleştirdiği “seviye belirleme sınavındaki” sorulardan esinlenilerek, çeşitli kaynaklardan (www.trmatematik.com, www.matematikcifatih.com, <http://egitek.meb.gov.tr/Sinavlar/detay.asp?ID=21&ID2=1&ID3=44>, 14.09.2011) yararlanılarak ve ilköğretim 6, 7, ve 8. programındaki tüm öğrenme alanlarını (MEB, 2005) kapsayacak biçimde titizlikle hazırlanmıştır. Sorularla ilgili uzman görüşleri doğrultusunda gerekli ekleme ve çıkarmalar yapılmış ve başlangıçta 50 soruluk

test oluşturulmuştur. Geliştirilen DBS, 2009-2010 eğitim-öğretim yılında gerçekleştirilen pilot çalışmada, 150 öğrenciye uygulanmıştır. Bu uygulamadan elde edilen verilerle, sınavın iç tutarlığı analiz edilmiş ve güvenilirliği düşük maddeler testten çıkarılmıştır. Güvenirliği yüksek 23 maddelik test elde edilmiştir. Ölçeğin iç tutarlık katsayısı 0,822 olarak bulunmuştur. Buna göre ölçek yüksek düzeyde güvenilir sayılmıştır (Özdamar, 1999; Tavşancıl, 2006:s. 29'daki alıntı). Sınavın 2010-2011 eğitim öğretim yılında yapılan esas uygulamasında, 23 maddelik DBS'den, sıkıntılı olduğu düşünülen olasılık ve istatistik ünitesine ait iki soru daha atılarak 21 maddelik bir ölçek elde edilmiştir. Ayrıca sınav soruları, öğrencinin bilgisini daha iyi yansıtması amacıyla klasik sınava dönüştürülmüştür. Sınav sorularının görsel yapısı aşağıdaki şekilde verilmektedir.

Şekil 2: Öğrenme Alanları

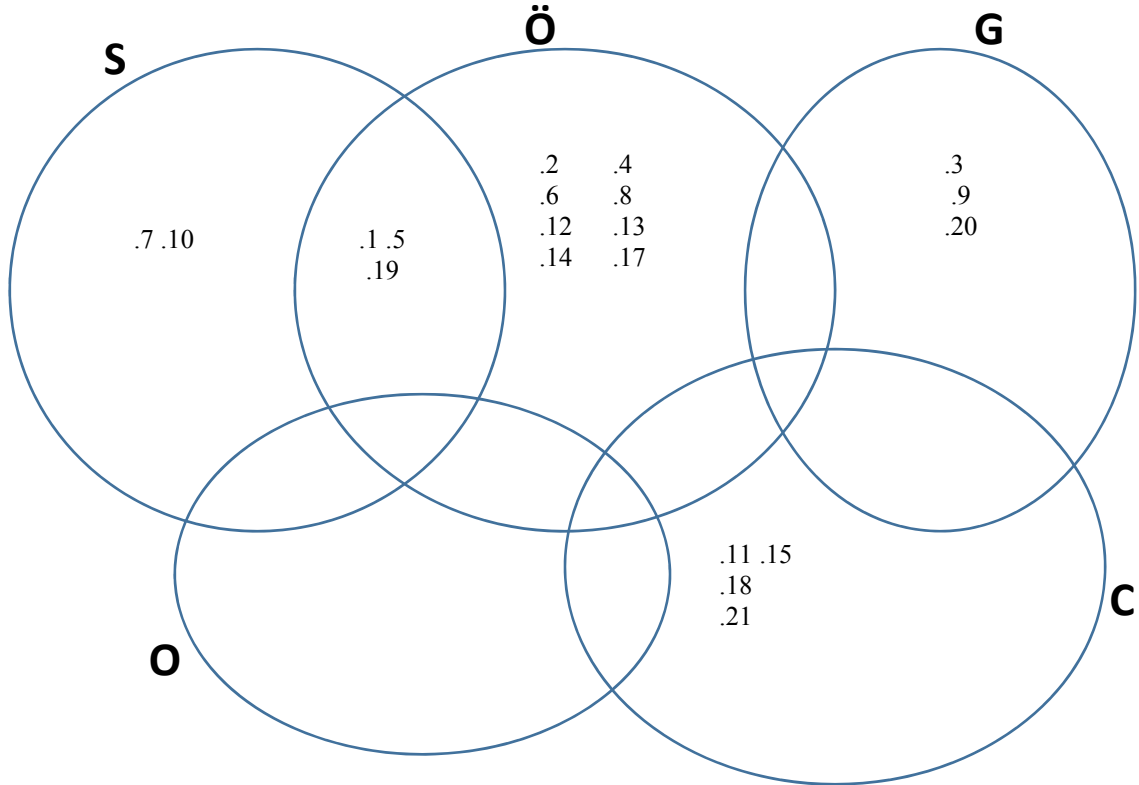

SAYILAR: S
GEOMETRİ: G
ÖLÇME: Ö
OLASILIK ve İSTATİSTİK: O
CEBİR: C

DBS sonunda öğrencilerin ön öğrenmelerle ilgili eksiklikleri ortaya konulmuştur. Öğrencilerin en çok asal sayı kavramında hata yaptıkları, alan ve hacim kavramlarında sıkıntı duydukları belirlenmiştir. Bunların giderilmesi için konu tekrarı yapılmış ve temel kavramların kritik noktaları üzerinde durulmuştur.

Öte yandan öğrencilerin daha önce problem çözme sürecini tam olarak kullanmadıkları varsayılarak, sınıfta dört ders saati boyunca problem çözme örnekleme yapıldı. Burada ana amaç, öğrencilerin ilk kez karşılaşacakları bu tür problemlere alışmasını sağlamaktır. Uygulamada öğrencilerle birlikte problem çözme adımları tek tek incelendi ve tartışıldı. Öğrenciden beklenenler, çözümde izlenecek yol-yöntem ve kullanılacak stratejiler açıklandı. Sınıfta çözülen problemler oluşturulurken, tek yönlü yaklaşımdan kaçınmak amacıyla bunların sözel, cebirsel ve geometri problemleri olmasına özen gösterildi.

Veri Toplama Araçları

Problem çözme basamakları ile performans göstergelerinin uyumluluğu göz önüne alınarak, öğrencilerin performans düzeylerini belirlemede problem çözme becerileri kullanılmıştır. Performans ölçümü için

oluşturulan problemlerin hazırlanması aşamasında farklı kaynaklardan çok sayıda problem incelenmiştir (<http://www.uky.edu/OtherOrgs/ARSI/www.uky.edu/pub/arsi/openresponsequestions/geometryorq.pdf>, <http://www.fi.edu/school/math2/index.html>, http://www.webcrawler.com/webcrawler_toolbar/ws/results/Web/Mathematics%20Performance/2/0/0/Relevance/zoom=off/qi=21/qk=20/bepersistence=true/_iceUrlFlag=7?_IceUrl=true, <http://www.nku.edu/~mathed/mori.html>, <http://www.pdfpop.com/ebook/open+ended+math+pssa/>). Belirlenen çok sayıda problem oluşturulan rubriğe uygun biçimde çözülmüş ve her birinin amaçlara uygun olup olmadığı tartışılmıştır. Bu konuda uzman görüşüne de başvurularak problemlerden bir kesimi atılmış ve bir kesimi de geliştirilerek kullanılabilir duruma dönüştürülmüştür. Başlangıçta ölçeklerin 8-10 problemden oluşması düşünülürken, pilot çalışma aşamasında öğrencilerin süre konusunda sıkıntı yaşamaması nedeniyle bu sayı ölçekte 3 ile sınırlandırılmıştır. Problemler uygulanmadan önce tekrar gözden geçirilmiş ve uzman desteği ile bunlara eklemeler ve çıkarmalar yapılmıştır

Uygulama

Ölçek uygulamasına geçilmeden önce, öğrencilerin daha önce problem çözme sürecini tam olarak kullanmadıkları varsayılarak sınıfta dört ders saati boyunca problem çözme örnekleme yapıldı. Burada ana amaç, öğrencilerin ilk kez karşılaşacakları bu tür problemlere alışmasını sağlamaktır. Uygulamada öğrencilerle birlikte problem çözme adımları tek tek incelendi ve tartışıldı. Öğrenciden beklenenler, çözümde izlenecek yol-yöntem ve kullanılacak stratejiler açıklandı. Sınıfta çözülen problemler oluşturulurken, tek yönlü yaklaşımdan kaçınmak amacıyla bunların sözel, cebirsel ve geometri problemleri olmasına özen gösterildi. Örnek problemler çözüldükten sonra, öğrencilere önceden hazırlanmış farklı problemleri içeren çalışma kağıtları dağıtıldı ve bu problemleri çözmeleri istendi. Yine zorlandıkları noktalarda öğrencilere rehberlik yapıldı.

BULGULAR VE YORUM

Öğrencilerin performans düzeylerini belirlemek amacıyla performans ölçme ölçeğinden aldıkları puanların ortalamaları, rubrikten alınabilecek minimum ve maksimum puanlara göre sınıflandırılmıştır. Puan aralığının 0-16 olduğu düşünülerek, 0-3.9 puan aralığı düşük, 4-7.9 puan aralığı orta, 8-11.9 puan aralığı yüksek ve 12-16 puan aralığı üst düzey performans seviyesi olarak belirlenmiştir. Seçilen aralıklara göre, uygulamanın başlangıç aşamasında, sınıftaki öğrencilerin performans düzeyleri Tablo 1'deki gibi oluşturulmuştur.

Tablo 1: Öğrencilerin PÖÖ Puanlarının Düzeyi.

Düşük		Orta		Yüksek		Üst Düzey	
0-3.9		4-7.9		8-11.9		12-16	
f	%	f	%	f	%	f	%
13	45	16	55	-	-	-	-

Tablodan görüldüğü gibi sınıfta yüksek ve üst düzey performansa sahip öğrenci bulunmamaktadır. Yığılma düşük ve orta performans düzeyindedir.

İçerikte bir farklılık var olabilir mi düşüncesine açıklık kazandırabilmek için öğrencilerin PÖÖ' ün alt bileşenlerinden aldıkları puanların incelenmesi düşünüldü. Bu bileşenlerdeki ortalama puanların, standart sapması ve genlikleri için Tablo 2 oluşturuldu.

Tablo 2: PÖÖ' ye Göre Öğrencilerin Her Bir Performans Bileşeninden Aldıkları Ortalama Puanların Karşılaştırılması.

Bileşen	N	\bar{X}	SS	Minimum	Maksimum
Anlama	29	1.6322	0.49877	1	2.67
Bağlantıların kurulması	29	1.1149	0.74682	0	2.33
Uygulama	29	0.7701	0.68489	0	2
Çıkarımlar ve geliştirme	29	0.2069	0.28749	0	1

Toplam	29	3.7241	2.21797	1	8
--------	----	--------	---------	---	---

Puan genlikleri 1. bileşenden 4. bileşene doğru, sıfıra yaklaşacak biçimde azalma göstermektedir. Bu durum bileşenlerin yapısı gereği bize sürpriz olmadı. Çünkü öğrencinin bir şey üretmesi derin anlayış ve muhakeme becerileri gerektirir (Bahr&Sudweeks, 2008). Oysa bizim eğitim sistemimiz en azından şimdilik bu yönde kazanımlar sağlayamamaktadır.

Deney öncesi edinilen SBS, DBS ve matematik dersi sene sonu akademik başarı puanları, PÖÖ puanları ve PÖÖ'den elde edilen bileşenler bazındaki ortalama puanlar irdelendiğinde, puanların kendi aralarında uyumluluk gösterdiği bulunmuştur. Öğrencilerin hem hazır bulunuşluk düzeyinin ipucu sayılan uygulama öncesi sınav puanları hem de PÖÖ'den aldıkları puanlar biri birine çok yakındır. Hazır bulunuşluk göstergelerinden birisi olan DBS ortalama puanları ile PÖÖ puanları arasındaki ilişkinin incelenmesi için korelasyon analizi yapılmış ve bu ikisi arasında pozitif yönde bir ilişki çıkmıştır. Bu bulgu, öğrencinin hazır bulunuşluk düzeyinin yükselmesinin, performans düzeyinin yükselmesine olumlu yönde katkı sağlayacağı anlamına gelir. Diğer taraftan elde edilen bu bulgu, önceki çalışmalardan elde edilmiş olan, “bir yere giriş sınavındaki öncü başarılar matematik, fen ve psikoloji alanlarında, sonradan gelecek olan performansla ilişkilidir” (Keeley&Hurst&House, 1994; Bridgeman, 1982:361-366; House vd., 1996:s.1 deki alıntı) bulgusu ile de uyusmaktadır. Bazı araştırmacılara göre öğrencilerin daha önceki öğrenme programından edindiği deneyim ve kazanımlar da yeni başarılar için önemli birer göstergedir. Örneğin, öğrencinin lise matematik müfredatı, üniversite matematik dersinde aldığı not için önemli bir göstergedir (House, 1995:157-167; House vd., 1996:s.2 deki alıntı)

Burada önemli olan bulgulardan birisi de, öğrencilerin performanslarının düşük ve orta düzeyde yer almasıdır. Daha önceki eğitimleri sürecinde gerçek anlamda problem çözme alışkanlığı edinmemiş olmaları bu durumun bir nedeni olarak görülebilir. Buna karşılık, üçüncü ve dördüncü bileşende bireysel farklılıklarını öne çıkarmak istememeleri, öz güven sahibi olmadıklarının bir göstergesi olarak da düşünülebilir.

SONUÇ, TARTIŞMA, ÖNERİLER

Birçok ülkedeki okullarda ve uluslar arası yarışmalarda, performansa dayalı ölçümün öne çıktığı görülmektedir. Aynı şekilde bu ülkelerde performans ölçümü ve performans gelişimi ile ilgili çok sayıda araştırma ve yayın yapılmaktadır. Buna karşılık, ülkemizdeki okullarda performans ölçümüne dayalı değerlendirme pek araştırma konusu edilmemiştir. Daha da kötüsü ülkemizde performans denilince öğretmenlerin aklına, çoğunlukla, ilköğretimde verilen dönem sonu ya da aylık süreli ödevler gelmektedir. Aslında bu ödevler genellikle el-işlem becerisini ya da belirli kaynaklardaki yazılanları birebir kes-kopyala işlemini gerektiren türdedir. Oysa performans ödevinin bunun yerine “ bilimsel çalışma koşullarını değiştirmeğe ve problemi çözme sürecinde öğrencileri düşünmeye ve muhakeme süreçlerini açığa çıkarmaya odaklayan ödevler” (Solano-Flores&Shavelson’a,1997.18; Palm, 2008: s.5’ deki alıntı) olarak düşünülmelidir. Bu yönden yaklaşıldığında her şeyden önce, performans kavramı ile performans ölçme konusunda ülkemizde kavram kargaşası yaşandığı söylenebilir. Performansa dayalı eğitim sistemine geçmeyi arzulayan MEB’nın öncelikle bu yanlış anlayışı ortadan kaldırması gerekir. Çünkü bu tür eksikliklerin giderilmesi uygulama sürecinin başlatılmasından daha önemlidir.

Günümüz eğitim sistemlerinde öğrenme ortamı kavramının anlamı değişmiştir. Sınıf ortamının yeniden düzenlenme ve donanımı yaklaşımlarının yanında, bu ortamın öğrenme ortamının yalnızca bir parçası olabileceği düşüncesi öne çıkmıştır. Buna göre gerçek anlamda öğrenme ortamı, bütün bilgilere ulaşılabilen, öğrencinin düşündüğünü söyleme rahatlığı sağlanmış ve bireysel farklılıkların öne çıkmasına yardımcı olan bir ortam olarak düşünülmektedir. Aynı düşüncenin bir ürünü olarak, yeğlenen öğrenme yaklaşımı, seçilen öğrenme yol-yöntemi ve kullanılması düşünülen ölçme araçlarına göre ortamın tasarımı da değişebilmektedir. Bu açıdan bakılarak öğrencinin performans gelişimini amaçlayan bir öğrenme ortamı tasarlandığında ve öğrenme etkinlikleri buna göre geliştirildiğinde, her bir konunun çok daha derinlemesine incelenmesi gereği ortaya çıkmaktadır(Darling-Hammond& Laura, 2008). Örneğin Uluslar Arası Öğrenci Başarısını Belirleme Programı (PISA) sonuçlarına göre(2006), Amerika Birleşik Devletleri, matematik alanında 40 ülke içinde 35. sırada yer almıştı. Bu olumsuz sonuç, ilgililerin özellikle PISA’ da üst düzeyde başarılı olan çeşitli ülkelerin öğrenme programlarını araştırmalarını gerektirdi. Derlenen bilgi ve verilerin birleştirilip analiz edilmesi sonucunda, üst düzey başarı gösteren ülke programlarının yalnızca konunun öğrenilmesi yerine, her konunun derinlemesine ele alınmasını, öğrencilerin muhakeme becerilerinin öne çıkarılmasını ve öğrenilen bilginin uygulamada kullanılmasına önem verdikleri gerçeği ile karşılaşmışlardır(Darling-Hammond& Laura, 2008). İlişkiler doğru kurulduğunda görüleceği gibi, PISA’da öne çıkarılan değişkenler birebir performans değişkenleridir. Dolayısıyla eğer uluslar arası düzeyde başarılı olmak isteniyorsa öğrenci performansının gelişimine yönelik bir öğrenme ortamı tasarımı, yol-yöntem seçimi ve ölçme aracı geliştirilmesi kaçınılmazdır.

Performans ölçümünde kullanılan ölçme araçları, öğrencinin sahip olduğu bilgi, beceri, yol-yöntem kullanabilme yeteneği ve muhakeme edebilme becerisini ölçmek durumundadır. Başarıya ulaşmak için eğitim sistemlerinin bu değişkenleri göz önüne alması söz konusudur. Öte yandan değişik, seçmeli, tamamlamalı, salt işleme dayalı ve salt hatırlamaya dayalı vb. testler ile sıralanan değişkenlerin ölçümü çok zor hatta imkânsızdır. Yapılması gereken bu değişkenleri ölçebilecek ölçme araçlarını geliştirmek ve uygulamaya geçirmektir. Belki o zaman öğrenme ortam ve tasarımı ile seçilen yol-yöntemin de önemi daha net çizgiler ile vurgulanabilir. Özellikle matematikte, öğrencilerin bu değişkenlerin her birindeki konumunu dolayısı ile performansını ölçebilmek için en azından rutin olmayan ve açık uçlu problem çözme sürecindeki becerilerini ve muhakeme gücünü belirlemek gerekir. Üstelik bu tür bir ölçme sonunda öğrencinin, anlama, modelleme, ilişkilendirme, muhakeme etme, bilgisini kullanabilme ve bilgisini geliştirme gibi yaşamda gerekli birçok becerisini de belirleme şansı yakalanmaktadır. Başka bir deyişle bu tür ölçme yaklaşımları öğrencileri günlük yaşama da hazırlamaktadır.

Günümüz ölçme yaklaşımlarına yumuşak bir geçiş yapmak için en azından sistem değişikliğinin başlangıç aşamasında, ölçme araçları hazırlanırken öğrencilerin birkaç “kısa açık uçlu soru” ile “rutin olmayan” problemi çözme sürecindeki davranışlarını incelemekle işe başlanabilir. Ancak burada ilke olarak, öğrencilerin düşünce üretmesi önemli varsayılmalı ve değerlendirilmelidir. Buna ek olarak, kısa süreli ve uzun süreli dönem ödevleri, öğrencilerin sıralanan beceri ve davranışlarını ölçecek biçimde düzenlenebilir. Öğrenme programı bu yönde yeniden düzenlenebilir. Daha da önemlisi kuramsal olarak oluşturulabilen bu yapı sürekli denetlenerek davranış haline getirme çabaları sürdürülebilir.

Lise öğrencileri için düzenlenen uluslar arası yarışmalarda üst düzey başarı gösteren ülkelerin öğrencileri öncelikle karşılaştığı olay, olgu ve problemi tam anlamayı, analiz etmeyi öğreniyorlar. Yine görülüyor ki bu ülkelerde öğrencinin bilgiyi uygulamada kullanması ve yaptığını açıklaması, kapsamlı biçimde yazılı sunum yapması önemsenmektedir. Dahası bu uluslar; öğrencilerin araştırma yapmasını, proje üretmesini ya da projede görev almasını, yaptığı tüm çalışmalarda üst düzey verimliliği hedeflemesini amaçlamaktadırlar. Bu kapsamın içeriğinde okul ödevlerinin, araştırma projelerinin, bilimsel buluşların ve ürünlerin geliştirilmesi çabalarının rapor haline getirilerek sunulması da vardır. Öğrencilerin akademik başarı puanlarını belirlenmenin bir parçası olarak kullanılan bu ölçmeler, öğretme ve öğrenme sürecini de etkilemektedir. Aynı zamanda bu çalışmalar öğrencilerin, üst düzey becerilerini ve problemleri çözme sürecinde bilgisini etkin biçimde kullanılmasını sağlayıcı ödevler üstlenmektedir (Darling-Hammond & Laura, 2008). Çalışmada önerilen ve uygulanan, problemi genişletme ve geliştirme etkinlikleri burada sözü edilen değişkenleri karşılamaya denk gelmektedir. O nedenle de önemlidir.

KAYNAKLAR

- Alkan, H., Ceylan, A.(2008). Matematik Öğretmen Adaylarının Matematiksel Düşünme Gelişimi İçin Öğrenme Ortamı ve Program Tasarımı. *D.E.Ü. Buca Eğitim Fakültesi. DPT Proje No: 2003 K120360.*
- Baker, E. L.(1997). Model-Based Performance Assessment. *New Directions in Student Assessment*, vol. 36, No. 4, s.247-254
- Baker, E.L (1997). Model-Based Performance Assessment. *Theory into Practice*, vol. 36, no.4, New Directions in Student Assessment. (Autumn), s.247-245.
- Chan, C.M.E. (2007). Using open-ended mathematics problems: A classroom experience (Primary). In C. Shagar & R. B. A. Rahim (Eds.), **Redesigning pedagogy: Voices of practitioners** (pp. 129-146). Singapore: Pearson Education South Asia.
- Darling-Hammond, Linda; McCloskey, Laura (2008). Assessment for Learning Around The World: What Would It Mean To Be Internationally Competitive?. *Phi Delta Kappan*, Vol. 90, No. 04, s.263-272.
- Elliott, Stephen N., Fuchs, Lynn S. (1997). The Utility of Curriculum Based Measurement and Performance Assessment As Alternatives To. *School Psychology Review*, vol. 26, Issue 2
- House, J. D.; Keely, E. J.; Hurst, R. S.(1996). Relationship Between Learner Attitudes, Prior Achievement, And Performance In A General Education Course: A Multiinstitutional Study. *International Journal of Instructional Media* v23 no3 s.257-71
- Huebner, T., Ketterle, J. (2007). “High Performance Schools for America”, *The Review of Policy Research* 24 no5. 488-9 S
- Marzano, R. J. ; Pickering, D. J. ; MCTighe, J.(1993), Assessing Student Outcomes, *Library of Congress Cataloging – in – Publication Data*, USA: ASCD

- M.E.B. (2009), *PISA Uluslar arası Öğrenci Başarılarını Değerlendirme Programı* <http://earged.meb.gov.tr/pisa/dil/tr/sunum.html> (05.03.2009)
- M.E.B. Talim ve Terbiye Kurulu Başkanlığı (2005). *Matematik Dersi Ortaöğretim Programı ve Kılavuzu (9-12. Sınıflar)*. Ankara.
- Niemi, D(1997). Cognitive Science, Expert-Novice Research, and Performance Assessment. Theory into Practice, vol. 36, no. 4, *New Directions in Student Assessment (Autumn)*, pp. 239-246.
- Niemi, D. (1997). Cognitive Science, Expert-Novice Research, and Performance Assessment. *Theory Into Practice*, vol. 36, no. 4, s.240-246
- Palm, T.(2008), Performance Assessment and Authentic Assessment: A Conceptual Analysis of the Literature, *Practical Assessment, Research&Evaluation*, Volume 13, Number 4, April.
- Programme for International Student Assessment*. (2004). Learning For Tomorrow's World. First Results from PISA 2003. <http://www.oecd.org/dataoecd/1/60/34002216.pdf> (09.07.2010).
- Slater, T. (2007), Performance Assesment. <http://www.flaguide.org/extra/download/cat/perfass/perfass.pdf> (10.02.2007)
- Tavşancıl, E. (2006). *Tutumların Ölçülmesi ve SPSS İle Veri Analizi*. Ankara: Nobel Yayın Dağıtım.
- http://oges.meb.gov.tr/docs/2010_OGES_b_1_YerlesTavanTabanPuani.pdf. (10.12.2010)
- www.trmatematik.com, www.matematikcifatih.com, (14.09.2011).
- <http://egitek.meb.gov.tr/Sinavlar/detay.asp?ID=21&ID2=1&ID3=44> (14.09.2011).

AÇILARI VE KENARLARI DİZİ OLUŞTURAN ÜÇGENLER İLE $x^2 + 3y^2 = z^2$ DİOPHANTİNE DENKLEMİ ARASINDAKİ İLİŞKİ ÜZERİNE¹

ON THE RELATIONS BETWEEN TRIANGLES WHICH ANGLES AND SIDES IN PROGRESSION WITH $x^2 + 3y^2 = z^2$ DIOPHANTINE EQUATION

Tayfun EŞEN
Yusuf İzzettin Horasanlı İlkokulu, Karatay-KONYA
tayfun_mat@hotmail.com

Ahmet CİHANGİR
Necmettin Erbakan Üniversitesi, Ahmet Keleşoğlu Eğitim Fakültesi, Meram-KONYA
acihangir@konya.edu.tr

ÖZET: Bu çalışmada; ilk olarak aritmetik üçgenler tanımlandı ve aritmetik üçgenlerden Pythagorean üçgenlerinin nasıl elde edileceği verildi. Sonra bir üçgenin kenarlarının nasıl aritmetik dizi olduğu ve hangi durumda harmonik ve geometrik dizi olacağı araştırıldı. Kenarları tamsayı olan üçgenler ile $x^2 + 3y^2 = z^2$ Diophantine denkleminin çözümleri arasındaki ilişki araştırıldı. Bu çözümlerden, kenarları tamsayı olan üçgenlerin üretilebileceği gösterildi.

Anahtar sözcükler: Heron Üçgeni, Aritmetik Üçgen, Pythagorean Üçgeni, Pell Denklemi, Bhaskara Denklemi.

ABSTRACT: By this study, firstly, we described the basic knowledge of arithmetic triangles and we gave information about how Pythagorean triangles are gained from arithmetic triangles. Then how to be a triangle sides an arithmetic progression and the case of triangle sides in geometric and harmonic progression are searched. And then the relations between triangles with integer sides and solution of diophantine equation $x^2 + 3y^2 = z^2$ has been described. Utilization of these studies, how to triangles with integer sides being derived has been proved.

Key Words: Heronion Triangle, Arithmetic Triangle, Pythagorean Triangle, Pell Equation, Bhaskara Equation.

¹Bu bildiri, Eşen' in (2010); "Açıları ve Kenarları Aritmetik, Geometrik ve Harmonik Dizi Oluşturan Üçgenler İle $x^2 + 3y^2 = z^2$ Diophantine Denklemi Arasındaki İlişki Üzerine Bir Araştırma" adlı Yüksek Lisans tezinden üretilmiştir.

1.GİRİŞ

Geometride üçgenler özel öneme sahiptir. Üçgenlerden de dik üçgenler daha ayrıcalıklıdır. Dik üçgenlerin, β pozitif bir reel sayı olmak üzere kenar uzunlukları $\alpha = \frac{\beta}{\sqrt{3}}$, β ve $\gamma = \frac{2\beta}{\sqrt{3}}$ şeklindeki özel hali iyi bilinir. Tüm bu üçgenler, açıları $A = 30^\circ$, $B = 60^\circ$, $C = 90^\circ$ olan benzer üçgenlerin bir sınıfını oluştururlar. Burada üçgenin A, B, C açıları arasındaki fark; $\varphi = 30^\circ$ olacak şekilde bir aritmetik dizi oluşturdukları açıktır. Diğer çok bilinen bir benzer üçgen sınıfı ise δ pozitif bir reel sayı olmak üzere, kenarları $\alpha = 3\delta$, $\beta = 4\delta$, $\gamma = 5\delta$ biçiminde verilen üçgenlerin sınıfıdır. Bunların hepsi dik üçgen olmakla birlikte, onların göze çarpan diğer bir özelliği de; α , β , γ kenar uzunluklarının (sırasıyla), $d = \delta$ farkı olacak şekilde aritmetik bir dizi oluşturmasıdır.

Şimdi de bu çalışmanın yapısından bahsedelim. Bölüm 2 de, kenarları aritmetik dizi olan Heron üçgenlerden yola çıkıp $x^2 + 3y^2 = z^2$ Diophantine denkleminde ulaşıldı. Ayrıca bilinen örnekler dışındaki diğer aritmetik dizilerden de bahsedildi. En son Heron üçgenini iki dik üçgene ayırdığımızda oluşan üçgenlerin de Heron üçgeni olduğu görüldü. Bölüm 3 te, kenarları ve açıları aritmetik dizi olan üçgenlere ilişkin birkaç sonuç ortaya

koyuldu. Açılı aritmetik dizi olan üçgenler incelendi; bunu yaparken de, $x^2 + 3y^2 = z^2$ Diophantine denkleminin pozitif tam sayılardaki parametrik çözümlerinin belirli bir alt kümesi kullanıldı ve örneklendirildi.

2. KENARLARI ARİTMETİK DİZİ OLAN HERON ÜÇGENLERİ

Bu bölümde kenarları aritmetik dizi olan Heron üçgenlerinden yola çıkarak $x^2 + 3y^2 = z^2$ Diophantine denklemleri ve arasındaki ilişkiler verildi. Ardışık tamsayı kenarlı Heron üçgenlerinin sonsuz sayıda olduğu ve bunların nasıl üretilebileceği gösterildi. Ayrıca, daha genel olarak herhangi bir aritmetik dizi kenarlı Heron üçgenlerini bulma probleminin tam bir çözümü farklı bir metotla verildi. Kenar uzunlukları ardışık tamsayılar olan Heron üçgenlerinin varlığı gösterildi ve onların listesi verilerek özellikleri incelendi (Fleener, 1987).

Tanım 2.1 $\alpha_1, \alpha_2, \alpha_3$ üç reel sayı olmak üzere bu dizinin, bir aritmetik dizi oluşturması için gerek ve yeter şart $2\alpha_2 = \alpha_1 + \alpha_3$; geometrik dizi oluşturması için gerek ve yeter şart $\alpha_2^2 = \alpha_1\alpha_3$; harmonik bir dizi oluşturması için gerek ve yeter şart ise $\frac{1}{\alpha_1}, \frac{1}{\alpha_2}, \frac{1}{\alpha_3}$ dizisinin bir aritmetik dizi oluşturmasıdır (Zelator, 2008).

Teorem 2.1 d kare çarpan ihtiva etmeyen bir tamsayı olmak üzere $x^2 + dy^2 = z^2$ Diophantine denkleminin bütün x, y, z tamsayı çözümleri; aralarında asal m ile n tamsayıları için

$$x = m^2 - dn^2, \quad y = 2mn, \quad z = m^2 + dn^2$$

+formüllerinden elde edilir (Şenay, 2007)

2.1. Ardışık Tamsayı Kenarlı Heron Üçgenleri

Bir üçgenin a, b, c kenar uzunlukları ve alanı tamsayı ise bu üçgene Heron Üçgeni denir. Ayrıca kenar uzunlukları a, b, c ve $s = (a + b + c) / 2$ olan bir üçgenin Heron formülü olarak bilinen alanı

$$A = \sqrt{s(s-a)(s-b)(s-c)}$$

olarak hesaplanır.

Bir üçgenin kenar uzunlukları $b-1, b, b+1$ olsun. O zaman $s = 3b/2$ olur ve bunu Heron formülünde yerine koyarsak;

$$A = \frac{b\sqrt{3(b^2 - 4)}}{4}$$

sonucuna ulaşırız. A nın tamsayı olması için $3(b^2 - 4)$ ifadesi bir kareye eşit olmalıdır. Bunu b nin durumuna göre irdeleyelim. Bu ifadeye; eğer b tek olsaydı o zaman $3(b^2 - 4)$ ifadesi tek olurdu ki bu A nın tamsayı olamayacağını gösterir. Bundan dolayı b çift olacağından $b = 2z$ alırsak o zaman alan

$$A = z\sqrt{3(z^2 - 1)}$$

olur. Burada alanın tamsayı, yani üçgenin Heron üçgeni olabilmesi için gerek ve yeter şart $3(z^2 - 1)$ ifadesinin bir tam kare olmasıdır. O zaman $z^2 - 1 = 3y^2$ olması gerektiğinden

$$z^2 - 3y^2 = 1$$

elde edilir. Bu z lerden elde edilen $b=2z$ kenarlı üçgenlerin küçük bir listesi **Tablo 2.1** ile verilmiştir.

Tablo 2.1. Kenarları Aritmetik Dizi Olan Üçgenler

n	a	b	c	Alan	n	A	b	c	Alan
1	3	4	5	6	4	193	194	195	16296
2	13	14	15	84	5	723	724	725	226974

3	51	52	53	1170	6	2701	2702	2703	3161340
---	----	----	----	------	---	------	------	------	---------

2.2 Diğer Aritmetik Dizilere Genişlemeler

Yukarıda tanımlanan üçgenlerden herhangi birisinin bütün kenarlarını bir k tam sayısı ile çarparsak, o zaman onlar da aritmetik dizi formunda olur ve alanı da k^2 ile çarpılmış hali olacağından alan da bir tamsayıdır. (15, 20, 25) veya (26, 28, 30) üçgenlerini bunlara örnek olarak verebiliriz. Ancak bu yolla elde edilemeyen aritmetik üçgenler var mıdır?

Önce, x tamsayısı $1 \leq x \leq b$ şartını sağlamak üzere, kenarlar $b - x$, b , $b+x$ olarak alalım. O zaman $s = 3b/2$ yarı çevre ve Heron formülünden alan da

$$A = \frac{b\sqrt{3(b^2 - 4x^2)}}{4}$$

bulunur. Daha önce açıklandığı üzere b çift olmak zorunda olduğundan $b=2z$ alırsak, o zaman alanı sadeleştirdiğimizde,

$$A = z\sqrt{3(z^2 - x^2)}$$

olur. Tekrar bu üçgenin Heron olması için gerek ve yeter şart $3(z^2 - x^2)$ ifadesinin bir tam kare olmasıdır. Burada $z^2 - x^2 = 3y^2$ dersek o zaman denklem $x^2 + 3y^2 = z^2$ biçiminde 2.dereceden homojen Diophantine denkleminde dönüşür. Böyle denklemlerin çözülebilir olduğunu, bu çözümlerin Teorem 2.1 ile verildiğini belirtelim. Çözümlerin her zaman iki değişkenli parametrik denklemlerin bir kümesi olarak verildiği açıktır. Yukarıdaki denklemlerin bütün çözümleri, λ ile κ tamsayı ve $g = (\lambda^2 - 3\kappa^2, 2\lambda\kappa, \lambda^2 + 3\kappa^2)$ olmak üzere;

$$x = \frac{|\lambda^2 - 3\kappa^2|}{g}, \quad y = \frac{2\lambda\kappa}{g}, \quad z = \frac{\lambda^2 + 3\kappa^2}{g}$$

biçiminde verilir. Denklem homojen olduğu için, primitif çözümlerin herhangi bir katı da bir çözüm ve λ ile κ da aralarında asal tamsayılar olurlar. Primitif çözümlerin λ ile κ nin farklı değerleri için oluşan üçgenlere karşılık geldiğini söyleyebiliriz ki bunlar **Tablo 2.2** ile verilmiştir.

Tablo 2.2. Kenarları Aritmetik Olan Üçgenin Artan b Değerleri

\square	\square	x	a	b	c	\square	\square	x	a	b	c
1	1	1	3	4	5	7	3	11	65	76	87
2	1	1	13	14	15	4	3	11	75	86	97
1	2	11	15	26	37	1	4	47	51	98	145
3	7	23	29	52	75	3	8	61	73	134	195
5	3	1	51	52	53	5	4	23	123	146	169

Tablodaki değerler yukarıdaki formüllerden elde edilmiştir. Tabi ki $x = 1$ alırsak Kesim 2.1 deki kenarları $b - 1$, b , $b+1$ olan üçgene dönüşür. Ayrıca x değerlerinin hepsi 12 modülüne göre 1 ya da -1 e kongrüent olduğuna dikkat çekilmelidir.

2.3 Bir Heron Üçgeninden İki Dik Heron Üçgeni Oluşturulması

Eğer kenarlar ardışık tamsayılar ise, yüksekliği h olarak aldığımızda, bu yükseklik b tabanını u ve v uzunluklarına ayırdığını **Şekil 2.1** de görürüz. O zaman Pythagorean teoreminde $b = 2z$ kullanırsak;

$$h^2 + u^2 = 4z^2 - 4z + 1$$

$$h^2 + v^2 = 4z^2 + 4z + 1$$

buluruz. Bu ifadelerin ikincisinden birincisini çıkarırsak,

$$(v - u)(v + u) = 8z$$

elde ederiz. Burada $v + u = 2z$ olduğundan $v - u = 4$ sonucuna ulaşırız. O zaman üçgenin h yüksekliği

$$h = \sqrt{(2z-1)^2 - (z-2)^2} = \sqrt{3z^2 - 3} = \frac{A}{z}$$

olup bu ifade bir tam sayıdır. Böylece her ikisi de Heron olup, bu üçgenlerin taban uzunlukları $z - 2$ ve $z + 2$ dir. Dolayısıyla onların farkı 4 tür.

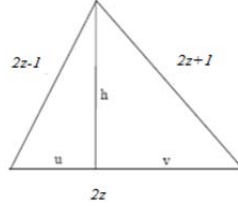

Şekil 2.1. Bir Heron Üçgeninin İki Dik Üçgene Ayrılması

Kesim 2.2 deki üçgenler için yukarıdakine benzer bir hesaplama ile yükseklik, tabanı $z - 2x$ ve $z + 2x$ uzunluklu parçalara ayırır. O zaman yükseklik önceden olduğu gibi $\sqrt{3z^2 - 3x^2}$ ifadesine dönüşür ki bu durumda da $\frac{A}{z}$ ifadesi tamsayı haline gelir. Böylece kenarları $b - x, b, b + x$ aritmetik dizisinden oluşan her bir Heron üçgeni, tabanları farkı $4x$ olan iki dik Heron üçgenine dönüşür. Benzer bir hesaplamayla diğer kenarlardan (çift olmayan) herhangi birisinin yüksekliğinden, iki Heron üçgeninin üretilemeyeceği gösterilebilir. Gerçekten herhangi bir Heron üçgeninin en az bir kenarının çift olduğunu ve birbirine dayanan iki dik üçgene ayrılabilceğini gösterebiliriz.

3. ÜÇGENDE AÇILARIN VE KENARLARIN DİZİ OLUŞTURMASI

Bu bölümde bir üçgenin açılarının ya da kenarının dizi oluşturması için trigonometrik durumlarının ne olması gerektiğini vereceğiz. Daha sonra üçgenin geometrik dizili üçgen olup olmadığını konusuna değineceğiz.

Burada ABC üçgenin açılara karşılık gelen A, B, C dizisi (**a**) ile kenar uzunluklarına karşılık gelen α, β, γ dizisi de (**s**) ile gösterilecektir.

Bir üçgende (**a**) nın dizi olabilmesi için B açısının 60° olması gerektiğini ve $\rho = \frac{2\tau}{\beta}$ nın oranının (2, 3] aralığına

düşüğünü göstereceğiz. Özel olarak; $\rho = 1 + \sqrt{3}$ için bu üçgen, $A = 30^\circ, B = 60^\circ, C = 90^\circ$ açılı üçgenlere dönüşür. Öte yandan, $\rho = 3$ için üçgen eşkenardır.

Teorem 3.1. Üçgeninin kenar uzunlukları α, β, γ , yarı çevresi τ ve üçgenin iç teğet çemberinin yarıçapı r ise;

$$r = \sqrt{\frac{(\tau - \alpha)(\tau - \beta)(\tau - \gamma)}{\tau}}$$
 olarak verilir.

İspat. Bir üçgenin çevresini 2τ ile yani $2\tau = \alpha + \beta + \gamma$ ile gösterirsek; yarı çevre $\tau = (\alpha + \beta + \gamma)/2$ olur.

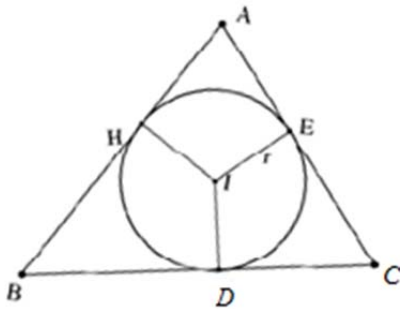

$$|AH| = |AE| = x \quad r = |IE|$$

$$|BH| = |BD| = y \quad r = |IH|$$

$$|DC| = |CE| = z \quad r = |ID|$$

Şekil 3.1. Üçgenin İç Teğet Çemberinin Merkezi

Şekil 3.1. den,

$$2x + 2z + 2y = 2\tau; \quad x + y + z = \tau, \quad x + y = \gamma, \quad y + z = \alpha \quad \text{ve} \quad x + z = \beta$$

olur. Buradan

$$\begin{aligned} r &= y \cdot \tan\left(\frac{B}{2}\right) = z \cdot \tan\left(\frac{C}{2}\right) = x \cdot \tan\left(\frac{A}{2}\right); \\ r &= (\tau - \alpha) \tan\left(\frac{A}{2}\right) = (\tau - \beta) \tan\left(\frac{B}{2}\right) = (\tau - \gamma) \tan\left(\frac{C}{2}\right) \end{aligned} \quad (3.1)$$

elde edilir. İki açının toplamının tanjantının;

$$\tan(\theta_1 + \theta_2) = \frac{\tan \theta_1 + \tan \theta_2}{1 - \tan \theta_1 \cdot \tan \theta_2}$$

olduğunu biliyoruz. Buradan;

$$\tan\left(\frac{A}{2} + \frac{B}{2}\right) = \frac{\tan \frac{A}{2} + \tan \frac{B}{2}}{1 - \tan \frac{A}{2} \cdot \tan \frac{B}{2}} \quad (3.2)$$

ve

$$\tan = \left(\frac{A}{2} + \frac{B}{2}\right) = \tan\left(90^\circ - \frac{C}{2}\right) = \cot\left(\frac{C}{2}\right) = \frac{1}{\tan\left(\frac{C}{2}\right)}$$

olacağından (3.1) ile (3.2) ifadelerinden hareketle,

$$\begin{aligned} \frac{\frac{r}{\tau - \alpha} + \frac{r}{\tau - \beta}}{1 - \frac{r^2}{(\tau - \alpha)(\tau - \beta)}} &= \frac{\tau - \gamma}{r} \Leftrightarrow [r(\tau - \alpha) + r(\tau - \beta)]r = (\tau - \gamma)[(\tau - \alpha)(\tau - \beta) - r^2] \\ \Leftrightarrow r^2 &= \frac{(\tau - \alpha)(\tau - \beta)(\tau - \gamma)}{\tau} \end{aligned}$$

veya dengi olan

$$r = \sqrt{\frac{(\tau - \alpha)(\tau - \beta)(\tau - \gamma)}{\tau}} \quad (3.3)$$

olur ki bu da aranandır. \square

Teorem 3.2. Bir üçgende (s) dizisinin bir aritmetik dizi oluşturması için gerek ve yeter şart $\cot(A/2), \cot(B/2), \cot(C/2)$ dizisinin de bir aritmetik dizi oluşturmasıdır.

İspat. Tanım 1.2.18 den $2\beta = \alpha + \gamma \Leftrightarrow 2 \cot\left(\frac{B}{2}\right) = \cot\left(\frac{A}{2}\right) + \cot\left(\frac{C}{2}\right)$

olduğunu göstermeliyiz. (3.1) i kullanarak;

$$\begin{aligned}
2 \cot\left(\frac{B}{2}\right) &= \cot\left(\frac{A}{2}\right) + \cot\left(\frac{C}{2}\right) \Leftrightarrow \\
\frac{2}{\tan(B/2)} &= \frac{1}{\tan(A/2)} + \frac{1}{\tan(C/2)} \Leftrightarrow \\
\Leftrightarrow \frac{\tau - \alpha}{r} + \frac{\tau - \gamma}{r} &= \frac{2(\tau - \beta)}{r} \Leftrightarrow \alpha + \gamma = 2\beta
\end{aligned}$$

elde ederiz (Zelator, 2008). □

Teorem 3.3. (s) dizisinin bir aritmetik dizi oluşturması için gerek ve yeter şart $\tan\left(\frac{A}{2}\right) \cdot \tan\left(\frac{C}{2}\right) = \frac{1}{3}$ olmasıdır.

İspat. Tanım 2.1 den

$$2\beta = \alpha + \gamma \Leftrightarrow \tan\left(\frac{A}{2}\right) \tan\left(\frac{C}{2}\right) = \frac{1}{3}$$

olduğunu göstermek yeterlidir. (3.1) in ve (3.3) ün kullanılmasıyla;

$$\begin{aligned}
\tan\left(\frac{A}{2}\right) \tan\left(\frac{C}{2}\right) &= \frac{1}{3} \Leftrightarrow \left(\frac{r}{\tau - \alpha}\right) \cdot \left(\frac{r}{\tau - \gamma}\right) = \frac{1}{3} \\
\Leftrightarrow \frac{r^2}{(\tau - \alpha)(\tau - \gamma)} &= \frac{1}{3} \Leftrightarrow \left[\frac{(\tau - \alpha)(\tau - \beta)(\tau - \gamma)}{\tau}\right] \cdot \frac{1}{(\tau - \alpha)(\tau - \gamma)} = \frac{1}{3} \\
\Leftrightarrow \frac{\tau - \beta}{\tau} = \frac{1}{3} &\Leftrightarrow \frac{2\tau - 2\beta}{2\tau} = \frac{1}{3} \Leftrightarrow \frac{(\alpha + \beta + \gamma) - 2\beta}{\alpha + \gamma + \beta} = \frac{1}{3} \\
\Leftrightarrow 3(\alpha + \gamma - \beta) &= \alpha + \gamma + \beta \Leftrightarrow \alpha + \gamma = 2\beta
\end{aligned}$$

olur ki ispat biter (Zelator, 2008). □

Teorem 3.4. Bir üçgenin kenar uzunluklarının kareleri olan $\alpha^2, \beta^2, \gamma^2$ nın bir aritmetik dizi oluşturması için gerek ve yeter şart $\cos A, \cos B, \cos C$ dizisinin bir aritmetik dizi oluşturmasıdır.

İspat. Tanım 2.1 den,

$$2 \cot B = \cot A + \cot C \Leftrightarrow 2\beta^2 = \alpha^2 + \gamma^2$$

olduğunu göstermeliyiz. Bunun için

$$\cot \theta = \frac{\cot^2(\theta/2) - 1}{2 \cot(\theta/2)}$$

yarım açı formülünü kullanarak başlayalım.

$$2 \cdot \cot B = \cot A + \cot C \Leftrightarrow \frac{\cot^2(B/2) - 1}{\cot(B/2)} = \frac{\cot^2(A/2) - 1}{2 \cot(A/2)} + \frac{\cot^2(C/2) - 1}{2 \cot(C/2)}$$

((3.1) den)

$$\begin{aligned}
\Leftrightarrow \frac{\left(\frac{(\tau - \beta)}{r}\right)^2 - 1}{\left(\frac{(\tau - \beta)}{r}\right)} &= \frac{\left(\frac{(\tau - \alpha)}{r}\right)^2 - 1}{2\left(\frac{(\tau - \alpha)}{r}\right)} + \frac{\left(\frac{(\tau - \gamma)}{r}\right)^2 - 1}{2\left(\frac{(\tau - \gamma)}{r}\right)}
\end{aligned}$$

($\beta = 2\tau - (\alpha + \gamma)$) nin kullanılması ve eşitliklerin 2τ ile çarpılması sonucunda

$$\begin{aligned}
&\Leftrightarrow 2\tau(\tau - \beta) - 2(\tau - \alpha)(\tau - \gamma) = \tau\beta - (\tau - \beta)\beta \\
&\Leftrightarrow 2\tau^2 - 2\tau\beta - 2\tau^2 + 2(\alpha + \gamma)\tau - 2\alpha\gamma = \tau\beta - \tau\beta + \beta^2 \\
&\Leftrightarrow -2\beta\tau + 2(\alpha + \gamma)\tau - 2\alpha\gamma - \beta^2 = 0 \Leftrightarrow -2\beta\tau + 2(\alpha + \gamma)\tau - 2\alpha\gamma - \beta^2 = 0 \\
&\Leftrightarrow -2\beta\tau + 2\tau[2\tau - \beta] - 2\alpha\gamma - \beta^2 = 0 \Leftrightarrow -2\beta\tau + 4\tau^2 - 2\tau\beta - 2\alpha\gamma - \beta^2 = 0 \\
&\Leftrightarrow -4\beta\tau + 4\tau^2 - 2\alpha\gamma - \beta^2 = 0 \Leftrightarrow -2\beta(2\tau) + (2\tau)^2 - 2\alpha\gamma - \beta^2 = 0 \\
&\Leftrightarrow -2\beta(\alpha + \beta + \gamma) + (\alpha + \beta + \gamma)^2 - 2\alpha\gamma - \beta^2 = 0 \\
&\Leftrightarrow -2\beta\alpha - 2\beta^2 - 2\beta\gamma + \alpha^2 + \beta^2 + \gamma^2 + 2\alpha\beta + 2\beta\gamma + 2\alpha\gamma - 2\alpha\gamma - \beta^2 = 0 \\
&\Leftrightarrow 2\beta^2 = \alpha^2 + \gamma^2
\end{aligned}$$

olarak bulunur ki ispat biter (Zelator, 2008). \square

Teorem 3.5. Bir üçgenin hem açılarının oluşturduğu **(a)** dizisi hem de kenarlarının oluşturduğu **(s)** dizisinin aritmetik olması için gerek ve yeter şart üçgenin eşkenar olmasıdır. Yani bu aritmetik dizilerde fark sıfırdır.

İspat. \Leftarrow : Eğer üçgen eşkenarsa **(a)** nın ve **(s)** nin aritmetik dizi olacağı açıktır. Çünkü bir üçgen eşkenar ise, $A = B = C = 60^\circ$ ve $\alpha = \beta = \gamma$ olur. Buradan açık olarak; **(a)** ile **(s)** dizilerinin her ikisi de farkı sıfıra eşit olan aritmetik dizilerdir. \Rightarrow : Yani, **(a)** ve **(s)** dizilerinin her ikisi de aritmetik dizi ise o zaman üçgen eşkenardır.

Gerçekten, Teorem 3.3 den dolayı **(s)** dizisi bir aritmetik dizi olduğunda $\tan\left(\frac{A}{2}\right) \cdot \tan\left(\frac{C}{2}\right) = \frac{1}{3}$ olur.

Öte yandan, **(a)** bir aritmetik dizi de olduğundan, özel olarak $B = 60^\circ$ elde ederiz ve burada $A + C = 120^\circ$ olduğundan $C = 120^\circ - A$ bulunur. Böylece, Teorem 3.3 den

$$\Rightarrow \tan\left(\frac{A}{2}\right) \tan\left(60^\circ - \frac{A}{2}\right) = \frac{1}{3} \Rightarrow \tan\left(\frac{A}{2}\right) \cdot \left[\frac{\tan 60^\circ - \tan\left(\frac{A}{2}\right)}{1 + \tan 60^\circ \tan\left(\frac{A}{2}\right)} \right] = \frac{1}{3}$$

ve $\tan 60^\circ = \sqrt{3}$ olduğundan

$$\begin{aligned}
3 \tan^2\left(\frac{A}{2}\right) - 2\sqrt{3} \tan\left(\frac{A}{2}\right) + 1 &= 0 \Leftrightarrow (\sqrt{3} \tan\left(\frac{A}{2}\right) - 1)^2 = 0 \\
\Leftrightarrow \tan\left(\frac{A}{2}\right) &= \frac{1}{\sqrt{3}} \Leftrightarrow (0^\circ < \frac{A}{2} < 90^\circ) \frac{A}{2} = 30^\circ; A = 60^\circ
\end{aligned}$$

ifadelerine ulaşırsınız ki buradan $B = 60^\circ$ ve $C = 60^\circ$ olur. Böylece $A = B = C = 60^\circ$ olup, üçgen eşkenardır (Zelator, 2008). \square

Teorem 3.6. δ bir reel sayı olmak üzere, **(s)** dizileri aritmetik dizi oluşturan dik üçgenler ise, üçgenin kenar uzunlukları $\alpha = 3\delta$, $\beta = 4\delta$, $\gamma = 5\delta$ biçiminde verilirler.

İspat. Böyle bir dik üçgenin α , β , γ kenar uzunlukları iki şartı sağlamalıdır:

$$\left. \begin{aligned} \gamma^2 &= \alpha^2 + \beta^2 \\ 2\beta &= \alpha + \gamma \end{aligned} \right\} \Rightarrow 4\gamma^2 = 4\alpha^2 + (\alpha + \gamma)^2 \Rightarrow 3\gamma^2 - 2\alpha\gamma - 5\alpha^2 = 0;$$

$$(3\gamma - 5\alpha)(\gamma + \alpha) = 0 \text{ ve } (\gamma + \alpha > 0 \text{ olduğundan})$$

$$3\gamma - 5\alpha = 0 \Rightarrow \gamma = \frac{5\alpha}{3}$$

ve $2\beta = \alpha + \gamma$ dan $\beta = 4\alpha/3$ elde ederiz ve δ pozitif reel sayı olacak şekilde, $\alpha = 3\delta$ koyarsak, $\alpha = 3\delta$, $\beta = 4\delta$, $\gamma = 5\delta$ ya ulaşırsınız (Zelator, 2008). \square

Teorem 3.7. Bir üçgenin α, β, γ kenar uzunlukları dizisinin bir harmonik dizi olması için gerek ve yeter şart $\sin^2\left(\frac{A}{2}\right), \sin^2\left(\frac{B}{2}\right), \sin^2\left(\frac{C}{2}\right)$ dizisinin de bir harmonik dizi olmasıdır.

İspat. Harmonik dizi tanımından

$$\frac{2}{\beta} = \frac{1}{\alpha} + \frac{1}{\gamma} \Leftrightarrow \frac{2}{\sin^2\left(\frac{B}{2}\right)} = \frac{1}{\sin^2\left(\frac{A}{2}\right)} + \frac{1}{\sin^2\left(\frac{C}{2}\right)}$$

olduğunu ispatlamalıyız. Sağ taraftan sol tarafa ulaşalım.

$$\frac{2}{\sin^2\left(\frac{B}{2}\right)} = \frac{1}{\sin^2\left(\frac{A}{2}\right)} + \frac{1}{\sin^2\left(\frac{C}{2}\right)} \Leftrightarrow 2 \operatorname{cosec}^2\left(\frac{B}{2}\right) = \operatorname{cosec}^2\left(\frac{A}{2}\right) + \operatorname{cosec}^2\left(\frac{C}{2}\right)$$

$$\Leftrightarrow 2 \left[1 + \cot^2\left(\frac{B}{2}\right) \right] = 1 + \cot^2\left(\frac{A}{2}\right) + 1 + \cot^2\left(\frac{C}{2}\right) \Leftrightarrow 2 \cot^2\left(\frac{B}{2}\right) = \cot^2\left(\frac{A}{2}\right) + \cot^2\left(\frac{C}{2}\right)$$

$$\Leftrightarrow \frac{2}{\tan^2\left(\frac{B}{2}\right)} = \frac{1}{\tan^2\left(\frac{A}{2}\right)} + \frac{1}{\tan^2\left(\frac{C}{2}\right)}$$

((3.1) den)

$$\frac{2(\tau - \beta)^2}{r^2} = \frac{(\tau - \alpha)^2}{r^2} + \frac{(\tau - \gamma)^2}{r^2} \Leftrightarrow 2\tau^2 - 2\tau(2\beta) + 2\beta^2 = \tau^2 - 2\tau\alpha + \alpha^2 + \tau^2 - 2\tau\gamma + \gamma^2$$

$$\Leftrightarrow 2\tau(\alpha + \gamma - 2\beta) = \alpha^2 + \gamma^2 - 2\beta^2 \Leftrightarrow (\alpha + \gamma + \beta)(\alpha + \gamma - 2\beta) = \alpha^2 + \gamma^2 - 2\beta^2$$

$$\Leftrightarrow \alpha^2 + \gamma^2 - 2\beta^2 + 2\alpha\gamma - \beta\gamma - \alpha\beta = \alpha^2 + \gamma^2 - 2\beta^2 \Leftrightarrow 2\alpha\gamma = \beta\gamma + \alpha\beta$$

$$\Leftrightarrow \frac{2\alpha\gamma}{\alpha\beta\gamma} = \frac{\beta\gamma}{\alpha\beta\gamma} + \frac{\alpha\beta}{\alpha\beta\gamma} \Leftrightarrow \frac{2}{\beta} = \frac{1}{\alpha} + \frac{1}{\gamma}$$

olur ki bu da aranandır. □

Teorem 3.8. (a) dizisinin aritmetik dizi ve **(s)** dizisinin de geometrik dizi olduğu üçgenler sadece eşkenar olanlardır (Yani farkı sıfır olan aritmetik diziler ve oranı 1 olan geometrik diziler).

İspat. Bir üçgende **(s)** dizisi bir geometrik dizi ve **(a)** bir aritmetik diziye, o zaman üçgenin eşkenar olması gerektiğini Teorem 3.5 den biliyoruz. Gerçekten eğer durum böyle ise o zaman $B=60^\circ$ ve $\beta^2 = \alpha\gamma$ şartları aynı zamanda sağlanması gerekirdi. Sinüs teoreminden,

$$\frac{\alpha}{\sin A} = \frac{\beta}{\sin 60^\circ} = \frac{\gamma}{\sin C}$$

olur. Böylece,

$$\beta^2 = \alpha\gamma \Rightarrow \beta^2 = \left(\frac{\beta \sin A}{\sin 60^\circ} \right) \cdot \left(\frac{\beta \sin C}{\sin 60^\circ} \right)$$

ve $\sin 60^\circ = \frac{\sqrt{3}}{2}$ olduğundan $\sin A \cdot \sin C = \frac{3}{4}$ elde edilir.

Öte yandan

$$\cos(A+C) = \cos(180^\circ - B) = \cos 120^\circ \Rightarrow$$

$$\Rightarrow \cos A \cos C - \sin A \sin C = -\frac{1}{2} \Rightarrow \cos A \cos C - \frac{3}{4} = -\frac{1}{2} \Rightarrow \cos A \cos C = \frac{1}{4}$$

olduğundan

$$\Rightarrow \left\{ \begin{array}{l} \sin A \sin C = \frac{3}{4} \\ \cos A \cos C = \frac{1}{4} \end{array} \right\} \Rightarrow \left\{ \begin{array}{l} \sin^2 A \sin^2 C = \frac{9}{16} \\ \cos^2 A \cos^2 C = \frac{1}{16} \end{array} \right\}$$

$$\Rightarrow \left\{ \begin{array}{l} (1 - \cos^2 A)(1 - \cos^2 C) = \frac{9}{16} \\ \cos^2 A \cos^2 C = \frac{1}{16} \end{array} \right\} \Rightarrow \left\{ \begin{array}{l} \cos^2 A + \cos^2 C = \frac{1}{2} \\ \cos^2 A \cos^2 C = \frac{1}{16} \end{array} \right\}$$

ifadelerini elde ederiz.

Eğer iki sayının toplamı S ve çarpımı P ise, onların $x^2 - Sx + P = 0$ biçimindeki ikinci dereceden denkleminin iki kökü olması gerektiğini hatırlayalım. Yukarıda verilenlere göre $\cos^2 A$ ve $\cos^2 C$ reel sayıları

$$x^2 - \frac{1}{2}x + \frac{1}{16} = 0 \Leftrightarrow \left(x - \frac{1}{4}\right)^2 = 0$$

ikinci dereceden denkleminin iki kökü olmalıdır. Bu ikinci dereceden denklemin $1/4$ biçiminde bir katlı kökü bulunur. Dolayısıyla $\cos^2 A \cos^2 C = \frac{1}{16}$ ve $\cos A > 0$, $\cos C > 0$ olduğundan hareketle $\cos A = \frac{1}{2} = \cos C$ elde edilir. Burada $A=60^\circ = C$ olacağından üçgen eşkenardır (Zelator, 2008). \square

Şimdi de kenarları geometrik dizi oluşturan rasyonel kenarlı ve rasyonel alanlı hiçbir üçgenin bulunmadığını ifade eden teoremi verelim.

Teorem 3.9. Kenarları geometrik dizi oluşturan rasyonel kenarlı ve rasyonel alanlı bir üçgen yoktur.

İspat. Burada, kenar uzunlukları geometrik dizi olan rasyonel alanlı üçgenler göz önüne alınmıştır. Kenarları a , ar , ar^2 (burada $a, r \in \mathbb{Q}$ ve $r \neq 0$) alırsak o zaman yarı çevre $s = a(1 + r + r^2)/2$ olur. Heron alan formülünü kullanırsak;

$$A = \frac{a^2}{4} \sqrt{(1+r+r^2)(-1+r+r^2)(1-r+r^2)(1+r-r^2)}$$

olur ve bu sonuç bir rasyonel sayı olmalıdır, ayrıca burada $y \in \mathbb{Q}$ iken

$$(1+r+r^2)(-1+r+r^2)(1-r+r^2)(1+r-r^2) = y^2$$

olmak zorundadır.

Burada $m, n \in \mathbb{Z}$, $(m, n) = 1$ ve $Y \in \mathbb{Z}$ iken $r = \frac{m}{n}$ alalım, o zaman tam sayı denklemi

$$Y^2 = (n^2 + mn + m^2)(-n^2 + mn + m^2)(n^2 - mn + m^2)(n^2 + mn - m^2)$$

olur. Bu denklemin sağındaki 4 terimin ikiye ikiye aralarında asal olduğu kolayca görülür. Bunun anlamı, buradaki her bir terimin kare olması gerektiğidir. Gerçekten de terimlerden ikisinin çarpımının da kare olacağı görülür. Bu yüzden

$$Y^2 = (n^2 + mn + m^2)(n^2 - mn + m^2) = n^4 + m^2n^2 + m^4$$

denklemini elde ederiz.

Bu denklemin tek çözümü $mn = 0$ iken ki çözümdür. Burada $n \neq 0$ olduğundan sadece $m = 0$ yani $r = 0$ olur. Böylece teoremi ispatlamış oluruz (Buchholz & MacDougall, 1998). \square

3.1 Açılı Dizi Olan Üçgenler

(a) dizisinin bir aritmetik dizi olması için gerek ve yeter şartın $B = 60^\circ$ olması gerektiği hemen görülür. Bu $2B = A + C$ ve $A + B + C = 180^\circ$ şartlarından çıkar. Üstelik kosinüs teoreminden;

$$\beta^2 = \alpha^2 + \gamma^2 - 2\alpha\gamma \cos 60^\circ \Leftrightarrow \beta^2 = \alpha^2 + \gamma^2 - \alpha\gamma \Leftrightarrow (\alpha + \gamma)^2 = \beta^2 + 3\alpha\gamma$$

elde ederiz.

Şimdi de, iki pozitif β ve τ reel sayıları verildiğinde $0 < \alpha \leq \beta \leq \gamma$ olacak şekilde $B = 60^\circ$ açılı bir tek üçgen tanımlandığında $\rho = \frac{2\tau}{\beta}$ oranı $(2, 3]$ yarı kapalı aralığına düştüğü görülecektir. Gerçekten $\beta > 0$, $\tau > 0$ ve $2 < \rho \leq 3$ şartlarından, tam olarak (gereklilik ve yeterlilik), $B = 60^\circ$ açılı bir tek üçgen belirlenir. Başka bir deyişle, $\rho = \frac{2\tau}{\beta}$ için $2 < \rho \leq 3$ olacak şekilde, iki pozitif β ve τ reel sayıları verildiğinde yukarıdaki koşulları sağlayan Euclides geometrisinde bir tek üçgen oluşturulabilir. Şimdi niçin böyle olduğunu görelim. Eğer α ve γ nin toplamı S ile çarpımları da P ile gösterilirse; yukarıda elde ettiğimiz bağıntıda $(\alpha + \gamma)^2 = \beta^2 + 3\alpha\gamma$ olacağından $S^2 = \beta^2 + 3P \Leftrightarrow P = \frac{S^2 - \beta^2}{3}$ olduğu sonucuna ulaşılır.

Öte yandan α ve γ reel sayıları, $X^2 - SX + P = 0$ ikinci dereceden denkleminin kökleridir. α ve γ reel kökler olduklarından, bu ikinci dereceden denklemin diskriminantı negatif olamaz. Buradan;

$$(-S)^2 - 4P \geq 0 \Leftrightarrow S^2 - 4P \geq 0 \Leftrightarrow S^2 - 4\left(\frac{S^2 - \beta^2}{3}\right) \geq 0 \Leftrightarrow 4\beta^2 \geq S^2$$

(β ve S nin her ikisi de pozitif olduğu için) $2\beta \geq S$ ve $S = 2\tau - \beta$ olduğundan,

$$2\beta \geq 2\tau - \beta \Leftrightarrow 3\beta \geq 2\tau \Leftrightarrow (\beta > 0 \text{ için}) \frac{3\beta}{\beta} \geq \frac{2\tau}{\beta}$$

elde ederiz; buradan da (açık olarak), $2\tau > \beta$; $\frac{2\tau}{\beta} > 1$ olur. Böylece $1 < \frac{2\tau}{\beta} \leq 3 \Leftrightarrow 1 < \rho \leq 3$ ifadesi bir gerek şart olarak ortaya çıkar.

Öte yandan $X^2 - SX + P = 0$ denkleminde geri dönersek; α ile γ , $\alpha \leq \gamma$ olacak şekilde denklemin kökleri olduğundan (ikinci derece denklem formülünden),

$$\alpha = \frac{S - \sqrt{S^2 - 4P}}{2}, \gamma = \frac{S + \sqrt{S^2 - 4P}}{2}$$

elde ederiz. Daha önceden $P = \frac{S^2 - \beta^2}{3}$ ve $S = 2\tau - \beta$ olarak verilen ifadeler kullanılırsa;

$$\alpha = \frac{2\tau - \beta - \sqrt{\frac{(3\beta - 2\tau)(\beta + 2\tau)}{3}}}{2}, \gamma = \frac{2\tau - \beta + \sqrt{\frac{(3\beta - 2\tau)(\beta + 2\tau)}{3}}}{2}$$

ifadesini veya denk olan,

$$\alpha = \frac{\beta\left(\frac{2\tau}{\beta} - 1\right) - \sqrt{\frac{\beta^2\left(3 - \frac{2\tau}{\beta}\right)\left(1 + \frac{2\tau}{\beta}\right)}{3}}}{2}, \gamma = \frac{\beta\left(\frac{2\tau}{\beta} - 1\right) + \sqrt{\frac{\beta^2\left(3 - \frac{2\tau}{\beta}\right)\left(1 + \frac{2\tau}{\beta}\right)}{3}}}{2}$$

ifadesini elde ederiz ve ayrıca $\rho = \frac{2\tau}{\beta}$ eşitliğini kullanarak,

$$\alpha = \frac{\beta}{2} \left[\rho - 1 - \sqrt{\frac{(3 - \rho)(1 + \rho)}{3}} \right], \gamma = \frac{\beta}{2} \left[\rho - 1 + \sqrt{\frac{(3 - \rho)(1 + \rho)}{3}} \right] \quad (3.4)$$

sonucuna ulaşırız. Fakat ek bir şart olarak; (3.4) den dolayı $\alpha > 0$ olması ($\beta > 0$ olduğundan)

$$\rho - 1 - \sqrt{\frac{(3-\rho)(1+\rho)}{3}} > 0$$

olmasına denk olduğundan;

$$\Leftrightarrow \rho - 1 > \sqrt{\frac{(3-\rho)(1+\rho)}{3}} \Leftrightarrow (1 < \rho \leq 3 \text{ için}) 3(\rho - 1)^2 > (3-\rho)(1+\rho)$$

$$\Leftrightarrow 3\rho^2 - 6\rho + 3 > 3 + 2\rho - \rho^2 \Leftrightarrow 4\rho^2 - 8\rho > 0 \Leftrightarrow 4\rho(\rho - 2) > 0;$$

sonucunu elde ederiz. Ayrıca $1 < \rho \leq 3$ olduğundan hareketle $2 < \rho \leq 3$ elde edilir ki bu da aranandır.

Sinüs teoreminden $\frac{\alpha}{\sin A} = \frac{\beta}{\sin 60^\circ} = \frac{\gamma}{\sin C} = 2R$ olduğunu hatırlayalım (Burada R, çevrel çemberin yarıçapıdır). Burada $B = 60^\circ$ alırsak, $\sin 60^\circ = \frac{\sqrt{3}}{2}$ olduğundan hareketle $\frac{\alpha}{\sin A} = \frac{2\beta}{\sqrt{3}} = \frac{\gamma}{\sin C}$ ifadesine ulaşırız. Bunu (3.4) ile birleştirirsek,

$$\sin A = \frac{\sqrt{3}}{4} \left[\rho - 1 - \sqrt{\frac{(3-\rho)(1+\rho)}{3}} \right], \quad \sin C = \frac{\sqrt{3}}{4} \left[\rho - 1 + \sqrt{\frac{(3-\rho)(1+\rho)}{3}} \right]$$

sonuçlarına ulaşırız. Ayrıca,

$$0 < \alpha \leq \beta \leq \gamma \Leftrightarrow 0^\circ < A \leq B \leq C < 180^\circ \Leftrightarrow (A + B + C = 180^\circ \text{ olduğundan})$$

$$0 < \sin A \leq \sin B \leq \sin C \leq 1 \Leftrightarrow 0 < \sin A \leq \sin 60^\circ \leq \sin C \leq 1 \Leftrightarrow$$

$$0 < \sin A \leq \frac{\sqrt{3}}{2} \leq \sin C \leq 1 \Leftrightarrow$$

$$0 < \frac{\sqrt{3}}{4} \left[\rho - 1 - \sqrt{\frac{(3-\rho)(1+\rho)}{3}} \right] \leq \frac{\sqrt{3}}{2} \leq \frac{\sqrt{3}}{4} \left[\rho - 1 + \sqrt{\frac{(3-\rho)(1+\rho)}{3}} \right] \leq 1$$

olur.

Eğer ilk eşitliğin işareti doğruysa, o zaman ikincisinin ve tersinin de doğru olması gerekir; burada $\rho = 3$ olması durumu tam olarak eşkenar üçgen olması durumuna karşılık gelir (yani, $A = B = C = 60^\circ$). Üstelik dördüncü eşitsizlikte, aynı işaretli olması durumu tam olarak $\rho = 1 + \sqrt{3}$ için sağlanır ki, bu $A = 30^\circ$, $B = 60^\circ$, $C = 90^\circ$ olması durumuna karşılık gelir. Eğer cebirsel işlemler yapılırsa son eşitsizliğin $[\rho - (1 + \sqrt{3})]^2 \geq 0$ olduğu görülür.

Tersine olarak $2 < \rho \leq 3$ olmak üzere (3.4) ün kullanılması ve sinüs teoremiyle birlikte $B = 60^\circ$ olarak belirleyebiliriz.

Son olarak ta $\alpha + \beta > \gamma$; $\alpha + \gamma > \beta$; $\beta + \gamma > \alpha$ şeklindeki üç üçgen eşitsizliğinin sağlandığını kolayca gösterebiliriz; üçüncü eşitsizlik, $\gamma \geq \beta \geq \alpha > 0$ dan dolayı hemen görülür; ikincisi ise $\alpha + \gamma = 2\tau - \beta$ dan kolaylıkla bulunur. Gerçekten $\alpha + \gamma > \beta \Leftrightarrow 2\tau - \beta > \beta \Leftrightarrow 2\tau > 2\beta \Leftrightarrow (\beta > 0 \text{ olduğundan}) \frac{2\tau}{\beta} > 2$

ifadesinden $\rho > 2$ olur ki bu geçerlidir. Çünkü ρ nun, $2 < \rho \leq 3$ şartını sağladığını varsaymıştık.

Şimdi $\alpha + \beta > \gamma$ üçgen eşitsizliğini ispatlayalım. (3.4) den dolayı

$$\alpha + \beta > \gamma \Leftrightarrow (\beta > 0 \text{ olduğundan})$$

$$\Leftrightarrow \frac{\sqrt{3}}{4} \left[\rho + 1 - \sqrt{\frac{(3-\rho)(1+\rho)}{3}} \right] + 1 > \frac{\sqrt{3}}{4} \left[\rho + 1 + \sqrt{\frac{(3-\rho)(1+\rho)}{3}} \right]$$

(Bu eşitsizliğin her tarafını 4 ile çarparsak)

$$\begin{aligned} \sqrt{3}(\rho+1)+4-\sqrt{3}(\rho+1) &> 2\sqrt{(3-\rho)(1+\rho)} \Leftrightarrow 2 > \sqrt{(3-\rho)(1+\rho)} \Leftrightarrow 4 > (3-\rho)(1+\rho) \\ \Leftrightarrow \rho^2 - 2\rho + 1 &> 0 \Leftrightarrow (\rho-1)^2 > 0 \end{aligned}$$

olur ki bu eşitsizlik $\rho \neq 1$ olduğunda doğrudur. Çünkü $2 < \rho \leq 3$ dür. Buna göre şu sonuçları elde ederiz.

1. Açılı A, B, C; kenar uzunlukları α, β, γ olan bir üçgende açılarının **(a)** dizisinin bir aritmetik dizi oluşturması için gerek ve yeter şart $B = 60^\circ$ olmasıdır. Burada $\rho = \frac{2\tau}{\beta}$ olmak üzere $2 < \rho \leq 3$ olacak şekildeki bir üçgende

çevre uzunluğu 2τ dur.

Tersine olarak $2 < \rho \leq 3$ olacak şekilde iki pozitif reel sayı 2τ ve β verildiğinde $B = 60^\circ$ açılı ve B açısını oluşturan kenarları;

$$\alpha = \frac{\beta}{2} \left[\rho - 1 - \sqrt{\frac{(3-\rho)(1+\rho)}{3}} \right] \text{ ve } \gamma = \frac{\beta}{2} \left[\rho - 1 + \sqrt{\frac{(3-\rho)(1+\rho)}{3}} \right]$$

biçiminde olan bir özel üçgen inşa edilebilir. Ayrıca bu üçgende;

$$\sin A = \frac{\sqrt{3}}{4} \left[\rho - 1 - \sqrt{\frac{(3-\rho)(1+\rho)}{3}} \right] \text{ ve } \sin C = \frac{\sqrt{3}}{4} \left[\rho - 1 + \sqrt{\frac{(3-\rho)(1+\rho)}{3}} \right]$$

olarak bulunur.

2. Üçgende $\rho = 1 + \sqrt{3}$ olduğu zaman, açılı A = 30° , B = 60° , C = 90° olan bir dik üçgen bulunur. Öte yandan $\rho = 3$ için üçgen eşkenardır.

3.2 Açılı Aritmetik Dizi Oluşturan Tamsayı Kenarlı Üçgenlerin Tanımlanması ve Belirlenmesi

Açıkça görüleceği gibi, kenar uzunlukları tamsayı olan ve açılarının **(a)** dizisi bir aritmetik dizi oluşturan bütün üçgenleri parametrik olarak tanımlayabilmek için, üç değişkenli $x^2 + 3y^2 = z^2$ Diophantine denkleminin genel çözümüne ihtiyacımız olacaktır. Burada $x^2 + ny^2 = z^2$ (n verilen pozitif bir tamsayıdır) biçimindeki üç değişkenli Diophantine denkleminin iyi anlaşıldığını ve genel çözümlerinin uzun zamandır bilindiği belirtelim. Fazla ayrıntıya girmeksizin, $x^2 + 3y^2 = z^2$ Diophantine denkleminin pozitif tamsayılardaki bütün çözümleri; d, κ, λ pozitif tamsayılar ve κ ile λ aralarında asal (yani $(\kappa, \lambda) = 1$ için) olmak üzere;

$$x = \frac{d | 3\kappa^2 - \lambda^2 |}{2}, \quad y = d\kappa\lambda, \quad z = \frac{d(3\kappa^2 + \lambda^2)}{2}$$

biçiminde tanımlandığını ifade edelim.

3.3 Örnekler

Aşağıda kenar uzunlukları tamsayı, **(a)** dizileri aritmetik dizi, $1 \leq \lambda, \kappa \leq 5$ eşitsizliklerini sağlayan λ ve κ farklı ikili olduğunda d parametresi 4 e eşit, λ ile κ nın her ikisinin de tek olduğu durumda $d = 1$ olacak şekildeki bütün üçgenlerin listesini veriyoruz. Aşağıdaki veriler; önceki bölümdeki formüllerden A açısının değerini yaklaşık olarak belirlemek için ve bilimsel hesap makinesi kullanılarak elde edilmiştir. Aşağıda on iki üçgen vardır.

Burada tüm benzer üçgenler sınıfı λ ve κ yı sabitleyerek ve d yi değiştirmek suretiyle elde edilmesine rağmen, aşağıdaki örnekler bu sınıfların birbiriyle bağlantılı olmadığını göstermektedir. Bunun nedeni; $\lambda, 3$ ün katı alındığı için üçgenin her bir kenarının 3 ün katı olmasıdır.

Örnek 3.3.1 $\kappa = \lambda = 1, d = 1, \alpha = \beta = \gamma = 1, \rho = 3, \sin A = \frac{\sqrt{3}}{2},$

$$A = 60^\circ, \varphi = 0^\circ, B = 60^\circ, C = 60^\circ$$

Örnek3.3.2 $\kappa = 2, \lambda = 1, d = 4, \alpha = 8, \beta = 13, \gamma = 15, \rho = \frac{36}{13} \approx 2.769230769,$

$$\sin A = \frac{4\sqrt{3}}{13}, A \approx 32.2042275^\circ, \varphi \approx 27.7957725^\circ, B = 60^\circ, C \approx 87.7957725^\circ$$

Örnek 3.3.3 $\kappa = 3, \lambda = 1, d = 1, \alpha = 3, \beta = 7, \gamma = 8, \rho = \frac{72}{28} = \frac{18}{7} \approx 2.57142851,$

$$\sin A = \frac{3\sqrt{3}}{14}, A \approx 21.7867893^\circ, \varphi \approx 38.2132107^\circ, B = 60^\circ, C \approx 98.2132107^\circ$$

Örnek 3.3.4 $\kappa = 4, \lambda = 1, d = 4, \alpha = 16, \beta = 49, \gamma = 55, \rho = \frac{120}{49} \approx 2.448979592,$

$$\sin A = \frac{8\sqrt{3}}{49}, A \approx 16.4264214^\circ, \varphi \approx 43.5735786^\circ, B = 60^\circ, C \approx 103.5735786^\circ$$

4. KAYNAKLAR

- Beauregard, R.A., and Suryanarayan, E.R. (1996), *Pythagorean Triples*, The hyperbolic view, The College Mathematics Journal, v.27, n.3, p.170-181.
- Beauregard, R.A. and Suryanarayan, E.R., (1997), *Arithmetic Triangles*, Math Magazine, v.70, n.2, p.13-17.
- Beauregard, R.A., and Suryanarayan, E.R., (2000), *General Arithmetic Triangles and Bhaskara's Equation*, The College Mathematics Journal, v.31, n.2, p.111-115.
- Dickson, L.E. (1971), *History of the Theory of Numbers*, Vol. II, 3th ed., Chelsea Publishing Company, New York.
- Eşen, T. (2010), *Açıları ve Kenarları Aritmetik, Geometrik ve Harmonik Dizi Oluşturan Üçgenler İle $x^2 + 3y^2 = z^2$ Diophantine Denklemi Arasındaki İlişki Üzerine Bir Araştırma*, S. Ü. Fen Bilimleri Enstitüsü (Yüksek Lisans Tezi)
- Fleenor, C.R. (1987), *Heronian Triangles with Consecutive Integer Sides*, J.Recr. Math., 28(2), p.113-115.
- MacDougall, J.A. (2003), *Heron Triangles With Sides in Arithmetic Progression*, Jour. Rec. Math. 31. v.3, p.189-196, Australia.
- Robbins, N. (1993), *Beginning Number Theory*, Wm.C. Brown, Oxford. London.
- Rosen, K.H. (1993), *Elementary Number Theory and Its Applications*, third edition, Addison-Wesley Publishing Company, New York.
- Sastry, K.R.S. (2000), *Geometric and Aritmetic Triangles*, Mathematics and Computer Education, v.34, n.3, p.259-264.
- Sierpinski, W. (1988), *Elementary Theory of Numbers*, published by Elsevier Publishing and distributed by North Holland, North- Holland Mathematical Library 32, Amsterdam.
- Şenay, H. (2007), *Sayılar Teorisi Dersleri*, Selçuk Üniversitesi Yayını, Dizgi Ofset Matbaacılık, Konya.
- Zelator, K. (2006), *The Diophantine Equation $x^2 + ky^2 = z^2$ and İntegral Triangles with A Cosine Value of $\frac{1}{n}$* , Mathematics and Computer Education, n.40, 3, p.191-197.

Zelator, K., (2008), *Triangle Angles and Sides in Progression and the Diophantine Equation $x^2 + 3y^2 = z^2$* ,
arxiv:0803.3778(pdf).

HERON ÜÇGENLERİNİN TEĞETLER ÇEMBERLERİNİN YARIÇAPLARI İLE $x^2 + 2y^2 = z^2$ DİOPHANTİNE DENKLEMİ ARASINDAKİ İLİŞKİLER ÜZERİNE¹

ON THE RELATIONS BETWEEN HERON TRIANGLE TANGENT OF THE RADII WITH $x^2 + 2y^2 = z^2$ DIOPHANTINE EQUATION

Yasemin YAVUZ EŞEN
Büyüksinan Mehmet Fatma Dalan İlkokulu, Karatay-KONYA
ysmnyavuz-86@hotmail.com

Ahmet CİHANGİR
Necmettin Erbakan Üniversitesi, Ahmet Keleşoğlu Eğitim Fakültesi, Meram-KONYA
acihangir@konya.edu.tr

ÖZET: Bu çalışmada ilk olarak, α, β, γ kenarlı bir ABC üçgeninin kenar uzunluklarına bağlı olarak $\rho_\alpha, \rho_\beta, \rho_\gamma$ yarıçaplarının alternatif basit formülleri bulundu. Bunu yaparken, kosinüs teoremi ve trigonometrik özdeşlikler kullanıldı. Sonra Pythagorean üçgenleri için $\rho_\alpha, \rho_\beta, \rho_\gamma$ yarıçap formülleri verildi. Son olarak tamsayı kenar uzunluklu ve tamsayı alanlı bütün ikizkenar üçgenlerin ailesi incelendi.

Anahtar sözcükler: İkizkenar Heron Üçgeni, Dış Yarıçap, İç Yarıçap, Pythagorean Üçgeni, Diophantine Denklemi.

ABSTRACT: By this study, firstly, we present an alternative simple derivation of the formulas for the radii $\rho_\alpha, \rho_\beta, \rho_\gamma$; in terms of triangle ABC's side lengths α, β, γ . To do so, we employ the Law of Cosines and two simple trigonometric identities. Then, This we do, in order to give formulas for the radii $\rho_\alpha, \rho_\beta, \rho_\gamma$, for triangles which are Pythagorean. Finally, to we examine the family of all isosceles triangles with integer side lengths and integral area.

Key words: Heron Isosceles Triangles, Pythagorean Triangles, External Radius, Internal Radius, Diophantine Equation.

¹Bu bildiri, Eşen' in (2010); "Heron Üçgenlerinin İç ve Dış Teğet Çemberlerinin Yarıçapları ile $x^2 + 2y^2 = z^2$ Diophantine Denklemi Arasındaki İlişki Üzerine Bir Araştırma" adlı Yüksek Lisans tezinden üretilmiştir.

1.GİRİŞ

Euclides düzlemindeki her bir üçgen için, dört karakteristik çember vardır. Bunlardan biri üçgenin iç teğet çemberi, diğer üç tanesi ise dış teğet çemberleridir. Bu dış teğet çemberlerinin her biri üçgenin kenarlarından birine teğettir ve aynı zamanda bu çemberlerin her biri, kenarların kendisine olmasa da diğer iki kenarı içeren doğruların uzantısına da teğettir. Bu üç çemberin her birinin merkezleri, üçgenin iki dış açıortayları ile bir iç açısının açıortayının kesim noktasıdır.

Bu çalışmanın iki amacı vardır. Birinci amaç; α, β, γ kenarlı bir ABC üçgeninin kenar uzunluklarına bağlı olarak $\rho_\alpha, \rho_\beta, \rho_\gamma$ yarıçaplarının alternatif basit formüllerini ortaya koymaktır. İkinci amaç ise; $\rho_\alpha, \rho_\beta, \rho_\gamma$ yarıçapları tam sayı olan bütün ikizkenar Heron üçgenlerinin ailesini parametrik olarak bulmaktır.

İkizkenar bir Heron üçgeninin eşkenar olamayacağı da açıktır. Çünkü eşkenar bir üçgenin tamsayı kenar uzunlukları $\alpha = \beta = \gamma$ olacağından, bu üçgenin alanı $E = \frac{\alpha^2 \cdot \sqrt{3}}{4}$ olarak bulunur ki alan irrasyonel bir sayıdır.

Dolayısıyla bir eşkenar üçgen, Heron üçgeni olamaz.

Çalışmamız, giriş dışında üç bölümden oluşmaktadır. İkinci bölümde; ikizkenar Heron üçgenlerinin ailesi parametrik olarak elde edildi. Burada parametrik olarak ikizkenar Heron üçgenlerinin bir S alt kümesi oluşturuldu ki bu ikizkenar Heron üçgenleri için; $\rho_\alpha, \rho_\beta, \rho_\gamma$ değerleri de tamsayılardır. Bu bölüm, bu üçgenlerle ilgili sayısal örnekleri içeren iki tablo ile bitirildi. Üçüncü bölümde; bir üçgenin çapları $2\rho, 2\rho_\alpha, 2\rho_\beta, 2\rho_\gamma$ olan iç ve dış teğet çemberleri incelendi. Bir ABC üçgeninin, A köşesindeki açısı 90° olan bir dik üçgen olduğu zaman

$$2\rho = \beta + \gamma - \alpha, 2\rho_\alpha = \alpha + \beta + \gamma, 2\rho_\beta = \alpha + \beta - \gamma, 2\rho_\gamma = \alpha + \gamma - \beta$$

olduğu gösterildi (bu durumda α , hipotenüs uzunluğudur). Devamında, Pythagorean üçgenleri verildi. Sonra Pythagorean üçgenlerinin ailesindeki $2\rho, 2\rho_\alpha, 2\rho_\beta, 2\rho_\gamma$ ifadeleri m ve n parametrelerine bağlı olarak verildi.

Ayrıca $(x, y) = 1$ olan $x^2 + 2y^2 = z^2$ şeklindeki Diophantine denkleminin tüm çözümlerini üreten parametrik formüller verildi. Bir dik kenarı bir tamsayının karesi olan sonsuz sayıda primitif Pythagorean üçgeninin mevcut olduğu belirtildi. Buradan hareketle; bir kenar uzunluğu tam sayının karesi olan Pythagorean üçgenlerinde $2\rho, 2\rho_\alpha, 2\rho_\beta, 2\rho_\gamma$ şeklindeki dört tam sayıdan hangisi veya hangilerinin kare olacağı sorusuna cevap arandı.

Ayrıca konuyla ilgili, sayısal örneklere de yer verildi. Son olarak bölüm, $x^2 + 2y^2 = z^2$ Diophantine denkleminin genel çözümünün verilmesiyle kapatıldı.

2. DIŞ YARIÇAPLARI $\rho_\alpha, \rho_\beta, \rho_\gamma$ TAM SAYILARI OLAN İKİZKENAR HERON ÜÇGENLERİ

3.

2.1 Kosinüs Teoremi ve İki Trigonometrik Özdeşlik

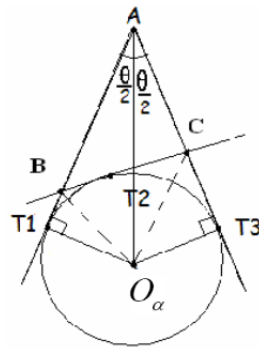

$$|AB| = \gamma, |BC| = \alpha, |AC| = \beta$$

$$|O_\alpha T_1| = |O_\alpha T_3| = \rho_\alpha$$

Şekil 2.1. Bir Üçgenin Dış Teğet Çemberinin Merkezi

Şekil 2.1 ile verilen ABC üçgeninde A iç açısını θ ile gösterirsek, kosinüs teoreminden

$$\alpha^2 = \beta^2 + \gamma^2 - 2\beta\gamma \cdot \cos \theta$$

olur. Buradan,

$$\cos \theta = \frac{\beta^2 + \gamma^2 - \alpha^2}{2\beta\gamma} \quad (2.1)$$

$$\tan\left(\frac{\theta}{2}\right) = \sqrt{\frac{1 - \cos \theta}{1 + \cos \theta}} \quad \text{ve} \quad \tan\left(\frac{\theta}{2}\right) = \sqrt{\frac{(s - \beta)(s - \gamma)}{s(s - \alpha)}} \quad (2.2)$$

bulunur.

2.2 ABC Üçgeninin $\rho_\alpha, \rho_\beta, \rho_\gamma$ Dış Yarıçapları İçin Formüller

Yukarıda verilen Şekil 2.1 de;

$$|AB| = \gamma, |BC| = \alpha, |AC| = \beta, |O_\alpha T_1| = \rho_\alpha = |O_\alpha T_3|$$

olsun ve ABC üçgeninin bir dış teğet çemberinin değme noktaları da sırasıyla T_1, T_2, T_3 ile gösterilsin. Burada $x = |BT_1| = |BT_2|$ ve $y = |T_2C| = |CT_3|$

olsun. Yukarıda $|AT_1| = |AT_3|$ olduğundan, $\gamma + x = \beta + y$ veya eşdeğeri

$$x - y = \beta - \gamma \quad (2.3)$$

olarak bulunur. Fakat aynı zamanda $|BT_2| + |T_2C| = |BC|$ olduğundan

$$x + y = \alpha \quad (2.4)$$

dır. Buradan

$$x = \frac{\beta - \gamma + \alpha}{2}, y = \frac{\alpha + \gamma - \beta}{2} \quad (2.5)$$

olur ki bu ifadelerden ve $O_\alpha T_1 A$ dik açısından,

$$\rho_\alpha = |AT_1| \cdot \tan\left(\frac{\theta}{2}\right) \quad (2.6)$$

olarak buluruz. Burada

$$|AT_1| = \gamma + x = \frac{\gamma + \beta + \alpha}{2} = s$$

olup buradan

$$\rho_\alpha = s \tan\left(\frac{\theta}{2}\right) \quad (2.7)$$

olarak bulunur. (2.7) ifadesinde (2.2) ifadesini kullanırsak;

$$\rho_\alpha = \sqrt{\frac{s(s-\beta)(s-\gamma)}{(s-\alpha)}} \quad (2.8)$$

formülüne ulaşırız. Eğer, Heron alan formülünü ve (2.8) u kullanırsak, $\rho_\alpha = \frac{E}{s-\alpha}$ denklemini elde ederiz.

Benzer şekilde ρ_β ve ρ_γ yı da; $\rho_\beta = \frac{E}{s-\beta}$, $\rho_\gamma = \frac{E}{s-\gamma}$ olarak buluruz.

ABC üçgeni, $\theta = 90^\circ$ olan bir dik açılı üçgen olduğunda (2.7) den kolaylıkla $\rho_\alpha = s$ olarak bulunur. Bu durumda $\beta^2 + \gamma^2 = \alpha^2$ olacağından, alan da $E = \frac{\beta\gamma}{2}$ olur. Burada E değeri yukarıdaki ρ_α , ρ_β , ρ_γ da yerine yazılır ve gerekli hesaplamalar yapılırsa,

$$\rho_\beta = \frac{\beta - \gamma + \alpha}{2} \quad \text{ve} \quad \rho_\gamma = \frac{\alpha + \gamma - \beta}{2} \quad (2.9)$$

olarak elde edilir.

Tersi de doğrudur. Yani, $\rho_\alpha = s$ ise, o zaman $\theta = 90^\circ$ dir. Böylece “ $\rho_\alpha = s$ olması için gerek ve yeter şart $\theta = 90^\circ$ olmasıdır.” ifadesini ispat etmiş oluruz (Bell, 2006: 341).

2.3 Bir Pythagorean Üçgeninin $\rho_\alpha, \rho_\beta, \rho_\gamma$ Dış Yarıçapları

Her Pythagorean üçgeni, bir dik açılı Heron üçgenidir. ABC bir Pythagorean üçgeni olduğu zaman, $\alpha^2 = \beta^2 + \gamma^2$ olacak şekilde α, β, γ pozitif tamsayıları vardır. Dolayısıyla $\theta = 90^\circ$ ve aynı zamanda

$$\beta = \delta(2mn), \gamma = \delta(m^2 - n^2), \alpha = \delta(m^2 + n^2) \quad (2.10)$$

olmasını veya alternatif olarak $\beta = \delta(m^2 - n^2), \gamma = \delta(2mn)$ olmasını gerektirir. ABC bir Pythagorean üçgeni olduğu zaman (2.9) ve (2.10) den

$$\rho_\alpha = \delta m(n+m), \rho_\beta = \delta n(m+n), \rho_\gamma = \delta m(m-n) \quad (2.11)$$

olarak bulunur.

2.4 İkizkenar Heron Üçgenlerinin Durumu

İkizkenar heron üçgenleri β, γ, α kenarları; $\beta = \gamma \neq \alpha$ olacak şekilde tamsayılar ve E alanı da tamsayı olan üçgenlerdir. Böyle üçgenleri tanımlayabilmek için, aşağıda verilip ispatlanacak olan Önerme 2.1 den faydalanacağız

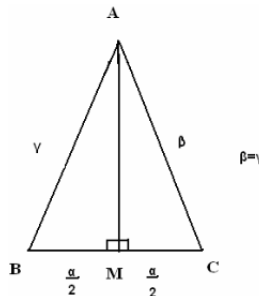

Şekil 2.2. İkizkenar Üçgenin Yüksekliği

Önerme 2.1. ABC, kenar uzunlukları $\gamma = |AB| = \beta = |AC| \neq \alpha = |BC|$ olan bir ikizkenar üçgen olsun. ABC ikizkenar üçgeninin; E alanı ile α ve $\beta = \gamma$ kenarlarının her biri pozitif tamsayılar olarak verilsin. Ayrıca A köşesinden $|BC|$ kenarına inilen yükseklik h olsun. O zaman α bir çift tamsayı ve h bir tamsayıdır (Zelator, 2008a: 7).

Aşağıdaki önerme, bütün ikizkenar Heron üçgenlerinin ailesini ifade etmektedir. Ayrıca; her bir ikizkenar Heron üçgeninin, iki eş Pythagorean üçgenini birbirine yapııştırarak (üçgenlerin dik kenarlarından biri ortak olacak şekilde) elde edilebileceğini göstermektedir.

Önerme 2.2. Kenar uzunlukları $\gamma = |AB| = \beta = |AC| \neq \alpha = |BC|$ olacak şekildeki bir ABC ikizkenar üçgeninde; α, β, γ kenar uzunlukları ve E alanı tamsayı olsun. Ayrıca A köşesinden $|BC|$ kenarına inilen yükseklik h olsun. O zaman

$$\alpha = 2\delta(m^2 - n^2), \quad h = \delta(2mn), \quad \gamma = \beta = \delta(m^2 + n^2)$$

veya alternatififi

$$\alpha = 4\delta mn, \quad h = \delta(m^2 - n^2), \quad \gamma = \beta = \delta(m^2 + n^2)$$

olur ki burada $m > n$, $(m, n) = 1$ (yani m ile n aralarında asal) ve $m + n \equiv 1 \pmod{2}$ (yani m ve n 'nin birisi tek diğeri çift) olacak şekilde δ, m, n tamsayılardır.

Karşıt olarak; $m > n$ olacak şekilde bazı δ, m, n tamsayıları için bir ABC üçgeninin α, β, γ kenar uzunlukları yukarıdaki formüllerden birini sağlarsa o zaman sırasıyla

$$h = \delta(2mn) \text{ veya } h = \delta(m^2 - n^2)$$

olur ve h bir tam sayıdır (Zelator, 2008a: 9).

Not: Burada $(m, n) = 1$ ve $m + n \equiv 1 \pmod{2}$ şartları, karşıt durumun geçerli olması için gerekli değildir.

Bu önermemiz ile ilgili sayısal örnekler aşağıdaki tablodaki gibidir.

Tablo 2.1(a): Önerme 2.2 de $\alpha = 2\delta(m^2 - n^2), h = \delta(2mn), \gamma = \beta = \delta(m^2 + n^2)$ ile ilgili örnekler (Eşen 2010)

m	n	\square	\square	$\square=\square$	h	m	n	\square	\square	$\square=\square$	h
2	1	1	6	5	4	4	1	1	30	17	8
3	2	1	10	13	12	5	2	1	42	29	20

Tablo 2.1(b) Önerme 2.2 de $\alpha = 4\delta mn, h = \delta(m^2 - n^2), \gamma = \beta = \delta(m^2 + n^2)$ ile ilgili örnekler (Eşen 2010)

m	n	\square	\square	$\square=\square$	h	m	n	\square	\square	$\square=\square$	h
2	1	1	16	5	3	4	1	1	32	17	15
3	2	1	48	13	5	5	2	1	80	29	21

Şimdi; bütün ikizkenar Heron üçgenlerinin tam bir parametrik tanımlaması mevcut olduğuna göre, buradan hareketle böyle üçgenlerin $\rho_\alpha, \rho_\beta, \rho_\gamma$ dış teğet çemberlerinin yarıçaplarının da tamsayılar olduğunu verebiliriz.

Teorem 2.1. İkizkenar Heron üçgenlerinin kümesi S olsun. Yani bütün ABC üçgenlerinin kenarları; $\gamma = |AB| = \beta = |AC| \neq \alpha = |BC|$ olacak şekildeki α, β, γ lar tamsayılar ve E alanı da tamsayı olsun. Ayrıca $\rho_\alpha, \rho_\beta, \rho_\gamma$ dış teğet çemberlerinin yarıçapları da tamsayılar olarak verilsin. O zaman S aşağıdaki iki ailenin birleşimidir. Bu aileler;

$$S_1 : \beta = \gamma = Kn(m^2 + n^2), \quad \alpha = 2Kn(m^2 - n^2)$$

ve bu ailede yarıçaplar

$$\rho_\alpha = Km(m^2 - n^2), \quad \rho_\beta = \rho_\gamma = 2Kmn^2$$

biçiminde veya

$$S_2 : \beta = \gamma = L(m - n)(m^2 + n^2), \quad \alpha = 4L(m - n)mn$$

ve bu ailede ise yarıçaplar

$$\rho_\alpha = 2Lmn(m + n), \quad \rho_\beta = \rho_\gamma = L(m + n)(m - n)^2$$

olarak verilir. Burada K ile L keyfi seçilen pozitif tamsayılar ve m ile n tamsayıları aralarında asal (m ile n biri tek iken diğeri çift) olup, $m > n$ dir (Zelator, 2008a: 10).

Parametreler için $1 \leq n < m \leq 6$, $L = K = 1$, $(m, n) = 1$ ve $m + n \equiv 1 \pmod{2}$ kısıtlamaları altında; yarıçapları $\rho_\alpha, \rho_\beta, \rho_\gamma$ tamsayıları olan ikizkenar Heron üçgenlerinin S_1 ailesi için bazı örnekler Tablo 2.2 ile S_2 ailesi için bazı örnekleri ise Tablo 2.3 ile verilmiştir.

Tablo 2.2 S_1 ailesinin m ve n elemanları için bazı sayısal örnekler (Eşen 2010)

K	n	m	\square	$\square=\square$	$\rho_\beta=\rho_\gamma$	ρ_α	K	n	m	\square	$\square=\square$	$\rho_\beta=\rho_\gamma$	ρ_α
1	1	2	6	5	4	6	1	2	5	84	58	40	105
1	1	4	30	17	8	60	1	3	4	42	75	72	28
1	1	6	70	37	12	210	1	4	5	72	164	160	45
1	2	3	20	26	24	15	1	5	6	110	305	300	66

Tablo 2.3 S_2 ailesinin m ve n elemanları için bazı sayısal örnekler (Eşen 2010)

L	n	m	\square	$\square=\square$	$\rho_\beta=\rho_\gamma$	ρ_α	L	n	m	\square	$\square=\square$	$\rho_\beta=\rho_\gamma$	ρ_α
1	1	2	8	5	3	12	1	2	5	120	87	63	140
1	1	4	48	51	45	40	1	3	4	48	25	7	168
1	1	6	120	185	175	84	1	4	5	80	41	9	360
1	2	3	24	13	5	60	1	5	6	120	61	11	660

3. BİR ÜÇGENİN İÇ TEĞET VE DIŞ TEĞET ÇEMBERLERİNİN ÇAPLARINI İÇEREN PYTHAGOREAN ÜÇGENLERİNİN BELİRLİ ÖZELLİKLERİ

Bu bölümde; çalışmamızın esas konusu olan Pythagorean üçgenlerinin ailesini üreten m ile n tamsayı parametrelerine bağlı iç ve dış teğet çemberlerinin çapları olan $2\rho, 2\rho_\alpha, 2\rho_\beta, 2\rho_\gamma$ ifadeleri için basit formüller verildi. Sonra, bir dik kenarı bir tamsayının karesi olan sonsuz sayıda primitif Pythagorean üçgeninin mevcut olduğu belirtildi. Sonra $(x, y) = 1$ olan $x^2 + 2y^2 = z^2$ şeklindeki Diophantine denklemlerinin tüm çözüm ailesini tanımlayan parametrik formülleri ifade edildi. Ayrıca bu denklemin genel çözümünün elde edilmesiyle ilgili bir taslak verilerek bölüm kapatıldı.

3.1 Üçgenlerin Genel Özellikleri

Üç pozitif α, β, γ tam sayıları verildiğinde, iki boyutlu Euclides düzleminde, üç kenar, $\alpha + \beta > \gamma, \alpha + \gamma > \beta, \beta + \gamma > \alpha$ üçgen eşitsizliklerini sağladığı sürece, kenarları α, β, γ olan üçgenler mevcut olacaktır. Buradan hareketle, α, β, γ tam sayılarına bağlı olarak; cetvel, pergel ve bazı diğer aletler kullanılarak böyle bir temsili üçgen (eş üçgenler ailesi denilen) oluşturulabilir. Böyle bir üçgen; cetvel veya pergel gibi geleneksel araçları kullanarak yapılamasa bile, kuşkusuz matematiksel anlamda var olacaktır.

Bir kenar uzunluğu bir tam sayının karesi olan ve $\alpha + \beta + \gamma$ (Çevre), $-\alpha + \beta + \gamma, \alpha - \beta + \gamma, \alpha + \beta - \gamma$ şeklindeki dört pozitif tamsayıdan birisi de bir tam sayının karesi olan tam sayı kenarlı sonsuz sayıda üçgen olduğunu görmek de kolaydır. Gerçekten, herhangi bir k pozitif tamsayısı için $\alpha = k^2$ ve bir l pozitif tamsayısı için $\alpha + \beta + \gamma = l^2$ olsun. Buradan $l > k$ ve $\beta + \gamma = l^2 - k^2 > k^2$ olacak şekilde β ve γ sayıları seçilebilir. Böylece l ve k pozitif tamsayılarının $l > k\sqrt{2} \Leftrightarrow l^2 > 2k^2$ şartını sağlaması gerektiği ve $-k^2 < \beta - \gamma < k^2$ veya eşdeğer şekilde $|\beta - \gamma| < k^2$ olması gerektiği ortaya çıkar. Kolayca görüleceği üzere; her bir $t = -k^2 + 1, -k^2 + 2, \dots, 0, 1, 2, \dots, k^2 - 2, k^2 - 1$ değeri için

$$\alpha = k^2, \beta = \frac{l^2 - k^2 + t}{2}, \gamma = \frac{l^2 - k^2 - t}{2}$$

ifadelerinden kenar uzunlukları tam sayılar olan üçgenleri oluşturulur ki burada üç üçgen eşitsizliğinin her biri sağlanır.

Dört tane $\alpha + \beta + \gamma, -\alpha + \beta + \gamma, \alpha - \beta + \gamma, \alpha + \beta - \gamma$ reel sayıları, üçgenin alanı için Heron alan formülündeki köklü ifade altında çarpanlar olarak belirlenir.

Bu çalışmanın 2. kesiminde göreceğimiz gibi; eğer üçgenin alanını, her bir $\alpha + \beta + \gamma, -\alpha + \beta + \gamma, \alpha - \beta + \gamma, \alpha + \beta - \gamma$ sayısı ile iki kez bölersek, sırasıyla $2\rho, 2\rho_\alpha, 2\rho_\beta, 2\rho_\gamma$ değerlerini elde ederiz. Bunlar dört önemli çemberin çaplarıdır. Bu çemberler; biri üçgenin içinde veya içine çizilen çember ve diğer üç çemberin her biri ise, bir kenara ve diğer iki kenarı içeren doğruların uzantısına teğet olan (fakat diğer iki kenarın kendisine teğet olmayan) çemberlerdir. Bu üç dış çemberin merkezlerinin her birisi, bir iç açıortay ve iki dış açıortayın kesim noktasıdır.

3.2 Bir ABC Üçgeninin α, β, γ Kenar Uzunlukları Cinsinden $2\rho, 2\rho_\alpha, 2\rho_\beta, 2\rho_\gamma$ Çapları İçin Formüller

Bir ABC üçgenine ilişkin bilgiler aşağıdaki Şekil 3.1 ve devamında verilmiştir.

$$\begin{aligned} |AB| &= \gamma, |BC| = \alpha, |CA| = \beta \\ |AD| &= x = |AE| \\ |BD| &= y = |BZ| \\ |CZ| &= z = |CE| \\ |DI| &= |IZ| = |IE| = \rho \\ |O_\alpha M| &= \rho_\alpha \end{aligned}$$

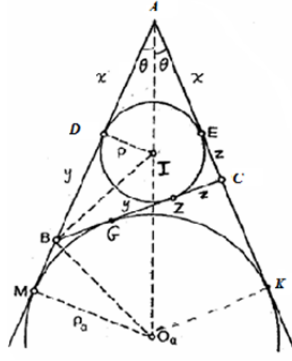

Şekil 3.1 Bir ABC Üçgenin İç Teğet ve Dış Teğet Çemberlerinin Yarıçapları

Şekil 3.1 den

$$\left. \begin{aligned} A(\widehat{ABI}) &= \frac{1}{2} \rho \gamma \\ A(\widehat{BIC}) &= \frac{1}{2} \rho \alpha \\ A(\widehat{AIC}) &= \frac{1}{2} \rho \beta \end{aligned} \right\} \Rightarrow A(ABC) = \frac{1}{2} (\rho \alpha + \rho \beta + \rho \gamma)$$

dir. Aynı zamanda,

$$\left\{ \begin{aligned} x + y &= \gamma \\ y + z &= \alpha \\ z + x &= \beta \end{aligned} \right\} \Leftrightarrow \left\{ \begin{aligned} x &= \frac{\beta + \gamma - \alpha}{2} \\ y &= \frac{\alpha + \gamma - \beta}{2} \\ z &= \frac{\alpha + \beta - \gamma}{2} \end{aligned} \right.$$

olduğunu da kolaylıkla görebiliriz.

Sonra $|AM| = |AK|$ dan (M ve K , $[AM]$ ve $[AK]$ nın uzantılarının O_α merkezli çemberin teğet noktalarıdır) $\gamma + |BM| = \beta + |CK|$ olur. Aynı zamanda $|BG| = |BM|$ ve $|CG| = |CK|$ dir. Burada $|BG| + |CG| = \alpha$ olduğundan $|BM| + |CK| = \alpha$ çıkar. Bunu $|BM| - |CK| = \beta - \gamma$ ile birleştirerek,

$$|BM| = \frac{\beta + \alpha - \gamma}{2} \quad \text{ve} \quad |CK| = \frac{\alpha + \gamma - \beta}{2}$$

olarak elde edilir. Üstelik IDA dik üçgeninde $\tan \theta = \rho / x$ olduğundan hareketle

$$\tan \theta = \frac{\rho_\alpha}{|AM|} = \frac{\rho_\alpha}{(\beta + \alpha + \gamma) / 2}$$

bulunur. Yukarıdan

$$|AM| = \gamma + |BM| = \gamma + \frac{\alpha + \beta - \gamma}{2} = \frac{\alpha + \beta + \gamma}{2}$$

olur ve bu sonucu ADI üçgeninden de elde ederiz. Böylece

$$\frac{\rho_\alpha}{(\beta + \alpha + \gamma) / 2} = \frac{\rho}{x}$$

olarak bulunur. Burada

$$x = \frac{\gamma + \beta - \alpha}{2} \quad \text{ve} \quad \rho = \frac{2 \cdot A(ABC)}{\alpha + \beta + \gamma}$$

olması durumunu kullanarak,

$$2\rho_\alpha = \frac{4 \cdot A(ABC)}{-\alpha + \beta + \gamma}$$

ifadesine varırız. Benzer şekilde diğer iki çap için de

$$2\rho_\beta = \frac{4.A(ABC)}{\alpha - \beta + \gamma}, 2\rho_\gamma = \frac{4.A(ABC)}{\alpha + \beta - \gamma}$$

ifadelerine ulaşırız. Böylece dört çap için

$$2\rho = \frac{4.A(ABC)}{\alpha + \beta + \gamma}, 2\rho_\alpha = \frac{4.A(ABC)}{\beta + \gamma - \alpha}, 2\rho_\beta = \frac{4.A(ABC)}{\alpha - \beta + \gamma}, 2\rho_\gamma = \frac{4.A(ABC)}{\alpha + \beta - \gamma} \quad (3.1)$$

formüllerini elde ederiz.

3.3 Dik Üçgenlerin Durumu

Eğer ABC bir dik üçgen ve A köşe açısının ölçümü 90° ise, o zaman α kenarı hipotenüs, β ile γ da diğer iki dik kenar olur. Buradan

$$\alpha^2 = \beta^2 + \gamma^2 \Leftrightarrow 2\beta\gamma = (\beta + \alpha + \gamma)(\beta - \alpha + \gamma)$$

bulunur. Ayrıca dik üçgende alandan

$$4.A(ABC) = 2\beta\gamma$$

olacağından dolayı ve (3.1) deki ilk iki formül birleştirildiği zaman

$$2\rho = \beta + \gamma - \alpha \text{ ve } 2\rho_\alpha = \alpha + \beta + \gamma$$

elde edilir. Burada $2\rho_\alpha$ nın dik üçgenin çevresine eşit olduğu açıktır.

Benzer şekilde, cebirsel işlemler sonucunda

$$2\beta\gamma = (\beta + \alpha - \gamma)[\alpha - (\beta - \gamma)];$$

bulunur.

$$4.A(ABC) = 2\beta\gamma$$

olduğundan ve (3.1) deki son iki formül birleştirildiği zaman

$$2\rho_\beta = \alpha + \beta - \gamma \text{ ve } 2\rho_\gamma = \alpha + \gamma - \beta$$

yi elde ederiz. Bu sonuçlar birleştirilirse,

$$2\rho = \beta + \gamma - \alpha, 2\rho_\alpha = \alpha + \beta + \gamma, 2\rho_\beta = \alpha + \beta - \gamma, 2\rho_\gamma = \alpha - \beta + \gamma \quad (3.2)$$

olarak buluruz.

3.4 Pythagorean Üçgenlerinin Durumu

Pythagorean üçgenlerinin veya üçlülerinin tüm (α, β, γ) ailesi, iyi bilinen

$$\alpha = \delta(m^2 + n^2), \beta = \delta(2mn), \gamma = (m^2 - n^2) \quad (3.3)$$

parametrik formülleri ile verilir ki burada m, n, δ pozitif tamsayılar, $(m, n) = 1, m > n$ ve $m + n \equiv 1 \pmod{2}$ olacak şekilde pozitif tamsayılardır (yani m ve n nin birisi çift iken diğeri tek olmak üzere).

$\delta = 1$ için (3.3) ifadesi

$$\alpha = m^2 + n^2, \beta = 2mn, \gamma = m^2 - n^2$$

olur ki burada

$$(m, n) = 1, m + n \equiv 1 \pmod{2}, m, n \in \mathbf{Z}^+ \text{ ve } m > n \quad (3.4)$$

olacağından bu (α, β, γ) Pythagorean üçgeninin veya üçlüsünün Tanım 1.2.6 ya göre primitif olduğu açıktır (Zelator, 2008b: 8).

Eğer (α, β, γ) bir primitif Pythagorean üçlüsüyse, (3.2) ve (3.4) formüllerinin birlikte uygulanmasıyla $2\rho, 2\rho_\alpha, 2\rho_\beta, 2\rho_\gamma$ çapları

$$2\rho = 2n(m - n), 2\rho_\alpha = 2m(n + m), 2\rho_\beta = 2n(m + n), 2\rho_\gamma = 2m(m - n) \quad (3.5)$$

olarak verilir.

Örnek 3.5.1 $m = 2, n = 1 \Rightarrow \alpha = 5, \beta = 4, \gamma = 3$ ve $2\rho = 2, 2\rho_\alpha = 12, 2\rho_\beta = 6, 2\rho_\gamma = 4$ olur.

3.5 Bir Dik Kenarının Uzunluğu Kare Olan Sonsuz Sayıdaki Primitif Pythagorean Üçgenleri

Bir Pythagorean üçgeninin kenar uzunluklarından sadece bir dik kenarının tam kare olabileceği daha önce verilmişti. Öte yandan Fermat tarihte, sonsuz iniş yöntemini ilk kullanan matematikçidir (Zelator, 2008b: 11). Fermat; bu yöntemi $x^4 + y^4 = z^2$ Diophantine denkleminin pozitif tamsayılarda çözümü olmadığını göstermek için kullanmıştır. Bu, birçok sayılar teorisi kitabında bulunabilen ve iyi bilinen bir sonuçtur. Öte yandan; “her iki dik kenar uzunluğu da bir tam sayının karesi olan Pythagorean üçgenlerinin bulunmadığı”, bu çözümün doğal bir sonucudur. Aşağıda, bir dik kenar uzunluğu kare olan tüm Pythagorean üçgenlerinin elde edilmiş yöntemi iki farklı yolla verilmiştir.

Teorem 3.1. (i) β dik kenarı çift ve kare olan sonsuz sayıda (α, β, γ) primitif Pythagorean üçgenleri veya üçlüleri vardır. Bu sonsuz aile parametrik olarak,

$$\alpha = m^2 + n^2, \beta = 2mn, \gamma = m^2 - n^2$$

biçiminde verilir. Burada β nın tam kare olabilmesi için $(t_1, t_2) = 1$ olacak şekilde t_1 ve t_2 tamsayılarına bağlı olarak $m = 2t_1^2$ ve $n = t_2^2$ veya $m = t_1^2$ ve $n = 2t_2^2$ olur. Ayrıca ilk durumda t_2 nin, ikinci durumda t_1 in tek olacağı ve aynı zamanda yazılış sırasıyla $2t_1^2 > t_2^2$ veya $t_1^2 > 2t_2^2$ olması gerektiği açıktır.

γ dik kenarı tek ve kare olan sonsuz sayıda (α, β, γ) primitif Pythagorean üçgenleri veya üçlüleri vardır. Bu sonsuz aile parametrik olarak,

$$\alpha = m^2 + n^2, \beta = 2mn, \gamma = m^2 - n^2$$

biçiminde verilir. Burada γ nın tam kare olabilmesi için t_1 ve t_2 ; $(t_1, t_2) = 1$, t_1 ile t_2 nin birisi tek diğeri çift (Yani $t_1 + t_2 \equiv 1 \pmod{2}$) ve $t_1 > t_2$ olacak şekildeki tamsayılar için $m = t_1^2 + t_2^2$, $n = 2t_1t_2$ olur (Bu $t_1 > t_2$ kabulü (α, β, γ) üçlüsünün tekrarlanmamasını garantiler) (Zelator, 2008b: 12).

Teorem 3.1 (i) için sayısal örnekler Tablo 3.1 de, Teorem 3.1 (ii) için sayısal örnekler Tablo 3.2 de verilmiştir.

Tablo 3.1 Teorem 3.1 (i) örnekler (Eşen 2010)

t_1	t_2	m	n	α	β	γ
1	1	2	1	5	4	3
2	1	8	1	65	16	63
3	1	18	1	325	36	323

$$(m = 2t_1^2, n = t_2^2)$$

t_1	t_2	m	n	α	β	γ
2	1	4	2	20	16	12
3	1	9	2	85	36	77
3	2	9	8	145	144	17

$$(m = t_1^2, n = 2t_2^2)$$

Tablo 3.2 Teorem 3.1 (ii) de $m = 2t_1^2, n = t_2^2$ için örnekler (Eşen 2010)

t_1	t_2	m	n	α	β	γ	t_1	t_2	m	n	α	β	γ
2	1	5	4	41	40	9	5	2	29	20	1241	1160	441
4	3	25	24	1201	1200	49	5	4	41	40	3281	3280	81
3	2	13	12	313	312	25	6	1	37	12	1513	888	1225

3. 6 Sayılar Teorisinden Bazı Sonuçlar

Bu kesimde sayılar teorisi ile ilgili konumuz için gerekli olan bazı sonuçlar verilmiştir.

Sonuç 3.1. $x^2 + 2y^2 = z^2$ Diophantine denkleminin pozitif tamsayılarda $(x, y) = 1$ olan bütün (x, y, z) çözümlerinin kümesi parametrik olarak;

$$x = |k^2 - 2\lambda^2|, y = 2k\lambda, z = k^2 + 2\lambda^2$$

biçiminde verilir ki burada k ile λ parametreleri aralarında asal olan pozitif tamsayılar ($k, \lambda \in \mathbf{Z}^+$ ($k, \lambda) = 1$) ve k tek ($k \equiv 1 \pmod{2}$) olur. Bu durumda x ile z nin her ikisi de tektir (Dickson, 1971: 225).

Sonuç 3. 2. $x^2 + y^2 = 2z^2$ Diophantine denkleminin pozitif tamsayılarda $(x, y) = 1$ olan bütün (x, y, z) çözümlerinin kümesi parametrik olarak;

$$x = |k^2 + 2k\lambda - \lambda^2|, y = |-k^2 + 2k\lambda + \lambda^2|, z = k^2 + \lambda^2$$

olarak verilir (simetriden dolayı, eğer (x, y, z) bir çözümse, böylece (y, x, z) nin de bir çözüm olduğu açıktır). Burada k ile λ ; $(k, \lambda) = 1$, $k + \lambda \equiv 1 \pmod{2}$ olacak şekilde pozitif tam sayılardır (Böylece, $(x, y) = 1$ olan herhangi bir çözümdeki x, y, z tamsayıları tek olmalıdır) (Dickson, 1971: 250).

3. 7 Bir Dik Kenarı ile $2\rho, 2\rho_\alpha, 2\rho_\beta, 2\rho_\gamma$ Çaplarından Birisi Kare Olan Primitif Pythagorean Üçgenleri

Eğer (α, β, γ) üçlüsü; $(m, n) = 1$, $m + n \equiv 1 \pmod{2}$ ve $m > n$ şartlarını sağlayan m, n pozitif tamsayıları için

$$\alpha = m^2 + n^2, \beta = 2mn, \gamma = m^2 - n^2$$

olacak şekildeki bir primitif Pythagorean üçlüsü ise, o zaman bu pythagorean üçgeninde bir dik kenar uzunluğu ile dört çapından birisi de kare olacak şekilde aşağıda verilen tam olarak sekiz kombinasyon vardır. Bunlar;

1) β kare, 2ρ kare; 2) β kare, $2\rho_\alpha$ kare; 3) β kare, $2\rho_\beta$ kare; 4) β kare, $2\rho_\gamma$ kare;

5) γ kare, 2ρ kare; 6) γ kare, $2\rho_\alpha$ kare; 7) γ kare, $2\rho_\beta$ kare; 8) γ kare, $2\rho_\gamma$ kare;

Aşağıda Teorem 3.2 de görüleceği üzere, 6 ve 8 kombinasyonları gerçekte gerçekleşemez. Yine Teorem 3.3 de verileceği üzere, geri kalan kombinasyonlar gerçekleşir ve her bir durumda (kombinasyonda) her bir üçlünün tüm ailesi, parametrik olarak tanımlanır.

Teorem 3.2 (i) γ dik kenar uzunluğu bir tek sayının karesi ve $2\rho_\alpha$ çapı (aynı zamanda üçgenin çevresi) da kare olan hiçbir Pythagorean üçgeni yoktur.

(ii) Tek sayılı γ kenar uzunluğu bir tek sayının karesi ve $2\rho_\gamma$ çapı da kare olan hiçbir Pythagorean üçgeni yoktur (Zelator, 2008b: 15).

Teorem 3.3 (i) β dik kenar uzunluğu bir çift sayının karesi ve $2\rho_\alpha$ çapı (aynı zamanda üçgenin çevresi) da kare olan primitif (α, β, γ) Pythagorean üçlülere; $\kappa \equiv 1 \pmod{2}$, $(\kappa, \lambda) = 1$ olacak şekildeki $\kappa, \lambda \in Z^+$ için $t_2 = |\kappa^2 - 2\lambda^2|$, $t_1 = 2\kappa\lambda$ olmak üzere $\alpha = m^2 + n^2$, $\beta = 2mn$, $\gamma = m^2 - n^2$ ve $m = 2t_1^2$, $n = t_2^2$, $2t_1^2 > t_2^2$ olarak bulunur ve F_1 ailesi ile verilir.

(ii) β dik kenar uzunluğu bir çift sayının karesi ve $2\rho_\beta$ çapının da kare olduğu primitif (α, β, γ) Pythagorean üçlülere; $\kappa \equiv 1 \pmod{2}$, $(\kappa, \lambda) = 1$ olacak şekildeki $\kappa, \lambda \in Z^+$ için $t_1 = |\kappa^2 - 2\lambda^2|$, $t_2 = 2\kappa\lambda$ olmak üzere $\alpha = m^2 + n^2$, $\beta = 2mn$, $\gamma = m^2 - n^2$ ve $m = t_1^2$, $n = 2t_2^2$, $t_1^2 > 2t_2^2$ olarak bulunur ve F_2 ailesi ile verilir.

(iii) β dik kenar uzunluğu bir çift sayının karesi ve $2\rho_\gamma$ çapının da kare olduğu primitif (α, β, γ) Pythagorean üçlülere; $\kappa + \lambda \equiv 1 \pmod{2}$, $(\kappa, \lambda) = 1$ olacak şekildeki $\kappa, \lambda \in Z^+$ için $t_1 = \kappa^2 + \lambda^2$, $t_2 = |-\kappa^2 + 2\kappa\lambda + \lambda^2|$ olmak üzere $\alpha = m^2 + n^2$, $\beta = 2mn$, $\gamma = m^2 - n^2$ ve $m = 2t_1^2$, $n = t_2^2$, $2t_1^2 > t_2^2$ olarak bulunur ve F_3 ailesi ile verilir.

(iv) γ dik kenar uzunluğu bir tek sayının karesi ve 2ρ iç çapının (aynı zamanda üçgenin çevresi) da kare olduğu primitif (α, β, γ) Pythagorean üçlülere tam olarak; $(\kappa, \lambda) = 1$, $\kappa + \lambda \equiv 1 \pmod{2}$ olacak şekildeki $\kappa, \lambda \in Z^+$ için $t_1 = \kappa^2$, $t_2 = \lambda^2$, $t_1 > t_2$ olmak üzere $\alpha = m^2 + n^2$, $\beta = 2mn$, $\gamma = m^2 - n^2$ ve $m = t_1^2 + t_2^2$, $n = 2t_1t_2$ olarak bulunur ve F_4 ailesi ile verilir.

(v) γ dik kenar uzunluğu bir tek sayının karesi ve $2\rho_\beta$ çapının da kare olduğu primitif (α, β, γ) Pythagorean üçlülere, tam olarak **(iv)**. şıktaki F_4 ailesinin elemanları ile verilir. Yani γ kare olduğundan dolayı, 2ρ nın bir kare olabilmesi için gerek ve yeter şart $2\rho_\beta$ nın da bir kare olmasıdır.

(vi) β dik kenar uzunluğu bir çift sayının karesi ve 2ρ iç çapının da bir kare olduğu primitif (α, β, γ) Pythagorean üçlülere tam olarak; $\kappa \equiv 1 \pmod{2}$ ve $(\kappa, \lambda) = 1$ olacak şekildeki $\kappa, \lambda \in Z^+$ için $t_1 = \kappa^2 + 2\lambda^2$, $t_2 = 2\kappa\lambda$, $t_1^2 > 2t_2^2$ olmak üzere $\alpha = m^2 + n^2$, $\beta = 2mn$, $\gamma = m^2 - n^2$ ve $m = t_1^2$, $n = 2t_2^2$ olarak bulunur ve F_6 ailesi ile verilir (Zelator, 2008b: 16).

Aşağıda Teorem 3.3 ün her bir şıkkında verilen formüllere bağlı örnekler yarı ayrı tablolarla verilmiştir.

Tablo 3.3 F_1 Ailesi için Örnekler (Eşen 2010)

K	\square	t_1	t_2	m	n	α	\square	\square	$\square\square\square$
1	1	2	1	8	1	65	16	63	144
3	2	12	1	288	1	82945	576	82943	166464
3	4	24	23	1152	529	1606945	1218816	1047263	3873024
5	7	70	73	9800	5329	124438241	104448400	67641759	296528400

Tablo 3.4 F_2 Ailesi için Örnekler (Eşen 2010)

K	\square	t_1	t_2	m	n	\square	\square	\square	$\square\square_\square$
1	2	7	4	49	32	3425	3136	1377	5184
5	1	23	10	529	200	319841	211600	239841	291600
3	7	89	42	7921	3528	75189025	55890576	50295457	80784144
7	2	41	28	1681	1568	5284385	5271616	367137	10188864

Tablo 3.5 F_3 Ailesi için Örnekler (Eşen 2010)

K	\square	t_1	t_2	m	n	\square	\square	\square	$\square\square_\square$
1	2	5	7	50	49	4901	4900	99	100
2	1	5	1	50	1	2501	100	2499	4900
2	3	13	17	338	289	197765	195364	30723	33124
2	5	29	41	1682	1681	5654885	5654884	3363	3364

Tablo 3.6 $F_4 = F_5$ Ailesi için Örnekler (Eşen 2010)

K	\square	t_1	t_2	m	n	\square	\square	\square	$\square\square_\square$
1	2	1	4	17	8	353	272	225	400
2	3	4	9	97	72	14593	13968	4225	24336
3	4	9	16	337	288	196513	194112	30625	360000
2	5	4	25	641	200	450881	256400	370881	176400

Tablo 3.7 F_6 Ailesi için Örnekler (Eşen 2010)

K	\square	t_1	t_2	m	n	\square	\square	\square	$\square\square_\square$
1	1	3	2	9	8	145	144	17	16
1	2	9	4	81	32	7585	5184	5537	3136
3	2	17	12	289	288	166465	166464	577	576
3	4	41	24	1681	1152	4152865	3873024	1498657	1218816

4. KAYNAKLAR

- Bell, Amy (2006). *Hansen's Right Triangle Theorem, Its Converse and a Generalization*, Forum Geometricorum, 6, 335-342.
- Dickson, Leonard E. (1971). *History of the Theory of Numbers (5th edition)*. New York: AMS Chelsea Publishing.
- Eşen Yavuz Y. (2010), *Heron Üçgenlerinin İç ve Dış Teğet Çemberlerinin Yarıçapları ile $x^2 + 2y^2 = z^2$ Diophantine Denklemi Arasındaki İlişki Üzerine Bir Araştırma*, S. Ü. Eğitim Bilimleri Enstitüsü (Yüksek Lisans Tezi)
- Sastry, Richard S. (2001). *Heron Triangles: A Gergonne-Cevian-and-Median Perspective*, Forum Geometricorum, 1, 17-24.
- Sierpinski, Waclaw (1988). *Elementary Theory of Numbers (2nd edition)*. Amsterdam: Published by Elsevier Publishing and distributed by North Holland.
- Şenay, Hasan (2007). *Sayılar Teorisi Dersleri (1.baskı)*. Selçuk Üniversitesi Yayınları- Konya
- Zelator, Konstantine (2006). *The Diophantine $x^2 + ky^2 = z^2$ and The Integral Triangles With a Cosine Value of $\frac{1}{n}$* , Mathematics and Computer Education, 40, 3, 191-197.
- Zelator, Konstantine (2008a). *Heron Isosceles Triangles with Integral External Radii $\rho_\alpha, \rho_\beta, \rho_\gamma$* , Arxiv: Math.0804.4640 (pdf).
- Zelator, Konstantine (2008b). *Certain Properties of Pythagorean Triangles involving the interior diameter 2ρ and the exterior diameters $2\rho_\alpha, 2\rho_\beta, 2\rho_\gamma$, Part II: The legs case*, Arxiv: Math.0803.3605 (pdf).

ORTAOKUL BEŞİNCİ SINIF ÖĞRENCİLERİNİN GELECEKTE BİLİM İNSANI OLMA İSTEKLERİNE ETKİ EDEN FAKTÖRLERİN BELİRLENMESİ

DETERMINING THE FACTORS HAVING EFFECT ON THE WISHES OF FIVE-CLASS STUDENTS TO BE SCIENTISTS IN THE FUTURE

Arş. Gör. Sema ÖZDEŞ
Necmettin Erbakan Üniversitesi Ahmet Keleşoğlu Eğitim Fakültesi
Sema.Sozdes@gmail.com

Yrd.Doç.Dr. Oktay Aslan
Necmettin Erbakan Üniversitesi Ahmet Keleşoğlu Eğitim Fakültesi
oktayaaslan@gmail.com

ABSTRACT: By this research it is aimed to determine the factors which have effects on the wishes of five-class students to become scientists in the future. At the end of the study it is understood that the things told by the teachers about the scientists and “the figure of asocial and mad scientist continuously studying in the lab” formed by the visual and written media have caused some girl and boy students to wish to become scientists in the future. However, the findings obtained from this study disprove the claim that the preference of the girls taking place in the literature to draw male scientist has been caused by the apprehension that girl students cannot become scientists and so they do not want to be scientists in the future. The girl students specified that they do not sympathize with the thought of being a scientist in the future because of their various interests or of the “figure of asocial and mad scientist continuously studying in the lab”.

Key Words: Scientist Perception, Television, Five-class students, Written Media, Visual Media

GİRİŞ

Mc Comas, bilimin doğasının ‘Bilim nedir ve hangi metotlarla çalışır?’, ‘Kimleri bilim insanı olarak adlandırırız ve onlar çalışmalarını nasıl yaparlar?’, ‘Sosyal ve kültürel içeriklerin bilime etkisi nedir?’ gibi pek çok soruyu bünyesinde barındırdığını belirtmektedir. Öğrencilerin bilim insanları hakkında sahip oldukları algılar üzerine odaklanılan araştırmaları incelediğimizde, kız öğrencilerin bilim insanı çizirken çoğunlukla erkek bilim insanı çizmeyi tercih etmelerinin nedeninin, kız öğrencilerin kadınların bilim insanı olamayacağını düşünmelerinden ve bu yüzden gelecekte bilim insanı olma fikrine sıcak bakmamalarından kaynaklanıyor olabileceği ihtimalinden bahsedilmektedir (Mead ve Metraux,1957; Chambers, 1983; Fung, 2002; Kaya, Doğan ve Öcal, 2008; Losh, Wilke ve Pop, 2008; Moeller, Krough ve Lykkegaard, 2013). Ancak Steinke’ nin (2007) de belirttiği gibi, burada sadece bir olasılıktan bahsedilmektedir. Kız öğrencilerin çoğunlukla erkek bilim insanı çizmeyi tercih etmelerinin nedenlerine yönelik veriler mevcut değildir. Bu araştırmada, ortaokul beşinci sınıf öğrencilerinin bilim insanları hakkındaki görüşlerinin, gelecekte bilim insanı olma konusundaki isteklerine etkisi olup olmadığına ışık tutmak amaçlanmıştır.

ARAŞTIRMANIN YÖNTEMİ

Araştırma, nitel bir çalışma olup, Konya ilinde ve İl Millî Eğitim Müdürlüğü’nün belirlediği Meram, Karatay ve Selçuklu bölgesinden ikişer olmak üzere toplam altı ortaokulda yürütülmüştür. Belirlenen okullardan, 101 erkek ve 86 kız olmak üzere toplam 187 gönüllü beşinci sınıf öğrencisi seçilmiş ve onlara Mead ve Metraux (1957) tarafından önerilen ve Chambers (1983) tarafından geliştirilen ‘Bir Bilim İnsanı Çiz Testi (DAST)’ uygulanmıştır. Öğrencilerden gözlerini kapatıp, bilim insanı hayal etmeleri ve zihinlerinde canlanan şeyi tarafımdan dağıtılan çizgisiz A4 kâğıtlarına çizmeleri istenmiştir. Ardından, tarafımdan verilen ikinci kâğıtlara anne ve babalarının mesleklerini, eğer televizyon izliyorlarsa bilimsel içerikli olduğunu düşündükleri televizyon programlarını, çizimlerindeki bilim insanının cinsiyetini ve nedenini, gelecekte bilim insanı olmayı isteyip istemediklerini ve nedenini belirtmeleri istenmiştir. Öğrencilerin verileri içerik analizine tabi tutulduktan sonra, daha spesifik cevapları olan öğrenciler tespit edilerek bu öğrencilerle ses kayıt cihazı eşliğinde yüz yüze görüşmeler gerçekleştirilmiştir.

BULGULAR

1. Öğrencilerin Ebeveynlerinin Mesleklerinin, Öğrencilerin Gelecekte Bilim İnsanı Olma Konusundaki Görüşlerine Etkisinin İncelenmesi

Araştırmaya katılan öğrencilerin annelerinin %65'inin ev hanımı, %13'ünün öğretmen, %1'inin akademisyen, %2'sinin bankacı, %1'inin avukat, %1'inin yönetici, %3'ünün hemşire, %1'inin polis, %1'inin tasarımcı, %1'inin gazeteci yazar, %2'sinin memur, %3'ünün esnaf, %2'sinin kasiyer, %2'sinin aşçı, %1'inin fabrika işçisi, %1'inin temizlikçi olduğu belirlenmiştir. Öğrencilere sorulan 'Gelecekte bilim insanı olmak ister misiniz?' sorusunu yanıtlayan öğrencilerin annelerinin meslekleri incelendiğinde, annelerinin mesleki durumları ve sosyoekonomik düzeyleri ile çocukların gelecekte bilim insanı olma istekleri arasında doğrusal bir ilişki tespit edilememiştir. Örneğin annesi ev hanımı olan çocukların yanıtlarını incelediğimizde, ister kız ister erkek olsun, çeşitli nedenlerden ötürü kimisi bilim insanı olmak istediğini belirtirken, kimisi olmak istemediğini belirtmiştir. Akademisyen annelerin çocuklarının yanıtlarını incelediğimizde, hem annesi hem de babası biyoloji bölümünde akademisyen olan bir kız öğrenci, mimar olmayı çok istediği için gelecekte bilim insanı olmak gibi bir düşüncesinin olmadığını belirtmiştir. Diğer taraftan, annesi genetik mühendisliğinde akademisyen olan başka bir kız öğrenci, annesine hayran olduğunu, onu bilim insanı olarak gördüğünü, bu yüzden gelecekte bilim insanı olmayı çok istediğini belirtmiştir. Benzer durum, diğer meslek gruplarında da mevcuttur.

Araştırmaya katılan öğrencilerin babalarının %17'sinin esnaf, %14'ünün serbest meslek sahibi, %11'inin öğretmen, %5'inin mühendis, %2'sinin akademisyen, %1'inin avukat, %1'inin savcı, %1'inin iş adamı, %4'inin polis, %2'sinin yönetici, %3'ünün subay, %3'ünün doktor, %1'inin eczacı, %1'inin mali müşavir, %1'inin müteahhit, %1'inin imam, %1'inin makinist, %1'inin reklamcı, %1'inin spiker, %1'inin laborant, %7'sinin memur, %1'inin emlakçı, %1'inin bankacı, %1'inin müzisyen, %1'inin dergi editörü, %2'sinin kuaför, %1'inin gardiyan, %2'sinin aşçı, %3'ünün işçi, %3'ünün hizmetli ve %6'sının işsiz olduğu belirlenmiştir. Öğrencilere sorulan 'Gelecekte bilim insanı olmak ister misiniz?' sorusunu yanıtlayan öğrencilerin babalarının meslekleri incelendiğinde, babalarının mesleki durumları ve sosyoekonomik düzeyleri ile çocukların gelecekte bilim insanı olma istekleri arasında doğrusal bir ilişki tespit edilememiştir. Öğrenciler ister kız, ister erkek olsun, çeşitli nedenlerden ötürü kimisi bilim insanı olmak istediğini belirtirken, kimisi olmak istemediğini belirtmiştir. Aynı durum işsiz babaların çocukları için de geçerlidir.

2. Öğrencilerin Çizimlerinde Bilim İnsanlarının Cinsiyetleri İle Öğrencilerin Gelecekte Bilim İnsanı Olma Konusundaki Görüşleri Arasında İlişki Olup Olmadığının İncelenmesi

Tablo 1. Bilim İnsanı Cinsiyeti-Bilim İnsanı Olma İsteği Frekans

Toplam Öğrenci Sayısı N= 187		İnsanı Olmak İsteyenler (N=)		İnsanı Olmak İstemeyenler (N=)		Çizimdeki Bilim İnsanları (N=)		Çizimdeki Bilim İnsanları (N=)	
		Kız Öğrenci	Erkek Öğrenci	Kız Öğrenci	Erkek Öğrenci	Kız Öğrenci	Erkek Öğrenci	Kız Öğrenci	Erkek Öğrenci
Çizimdeki Bilim İnsanı Cinsiyeti	Kadın	6	0	0	0	0	0	0	0
	Erkek	45	65	16	20	2	2	12	13
	Kadın ve Erkek	4	1	1	0	0	0	0	0

Tabloyu incelediğimizde, 101 erkek öğrenci içerisinde sadece 1 öğrencinin çiziminde kadın bilim insanı mevcut olduğunu; 86 kız öğrenci içerisinde sadece 11 öğrencinin çiziminde kadın bilim insanı mevcut olduğunu ve geriye kalan 175 öğrencinin tamamının erkek bilim insanı çizdiğini görmekteyiz. Gelecekte bilim insanı olmak isteyen öğrencilerin frekanslarına baktığımız zaman, sadece kadın bilim insanı çizen 6 kız öğrencinin

tamamının gelecekte bilim insanı olmak istediğini, sadece erkek bilim insanı çizen 75 kız öğrencinin 45'inin gelecekte bilim insanı olmak istediğini, 16'sının bilim insanı olmak istemediğini, 2'sinin kararsız olduğunu, 12'sinin yanıt vermediğini görmekteyiz. Hem kadın hem de erkek bilim insanı çizen 5 kız öğrenciden 4'ünün gelecekte bilim insanı olmak istediğini, 1'inin istemediğini görmekteyiz. Erkek bilim insanı çizen 100 erkek öğrencinin 65'inin bilim insanı olmak istediğini, 20'sinin bilim insanı olmak istemediğini, 2'sinin kararsız olduğunu, 13'ünün yanıt verdiğini görmekteyiz.

2.1. Erkek Bilim İnsanı Çizen Erkek Öğrencilerin Erkek Bilim İnsanı Çizmelerinin Nedenlerinin Analizi

Erkek bilim insanı çizen erkek öğrencilerin yanıtları incelendiğinde, 'Dünyada erkek bilim insanı sayısı, kadın bilim insanı sayısından fazladır. Öyle olmasaydı, Televizyonda ve kitaplarda kadın bilim insanlarından çok erkek bilim insanlarını görmezdim.' yanıtının frekansının çok yüksek olduğu (N=62) görülmektedir. Öğrencilerden sadece 5'i kendisini hayal ettiği için erkek bilim insanı çizdiğini ifade etmiştir. Verilen diğer yanıtları incelediğimizde ise; öğrencilerin bilim insanlarına yönelik algılarına televizyonda izledikleri programların, okudukları kitapların ve

dergilerin, öğretmenlerinin etki ettiğini görmekteyiz. Örneğin bir öğrencinin, ‘İzlediğim filmde zombiye çeviren virüsü erkek bilim insanları geliştiriyordu.’ yanıtı görsel medyanın etkisini gözler önüne sermektedir.

2.2. Erkek Bilim İnsanı Çizen Kız Öğrencilerin Erkek Bilim İnsanı Çizmelerinin Nedenlerinin Analizi

Erkek bilim insanı çizen kız öğrencilerin yanıtları incelendiğinde, ‘Dünyada erkek bilim insanı sayısı, kadın bilim insanı sayısından fazladır. Öyle olmasaydı, Televizyonda ve kitaplarda kadın bilim insanlarından çok erkek bilim insanlarını görmezdim.’ yanıtının frekansının çok yüksek olduğu (N=40) görülmektedir. ‘Ben bilim insanı değil, bilim adamı çizmek istedim.’ yanıtına baktığımızda, bu yanıtı veren öğrencinin bilim insanı ile bilim adamı kavramlarının farklı anlamlara geldiğini düşündüğünü görmekteyiz. Verilen diğer yanıtları incelediğimizde ise; öğrencilerin bilim insanlarına yönelik algılarına televizyonda izledikleri programların, okudukları kitapların ve dergilerin, öğretmenlerinin etki ettiğini görmekteyiz. ‘*Kadın bilim insanı hiç görmedim.’ diyen öğrencilerden birinin hem annesi, hem de babası akademisyendir. Kendisiyle yüz yüze görüşme yaptığımızda, anne ve babasının icatları olmadığı için, onları bilim insanı olarak görmediğini belirtmiştir. Gelecekte bilim insanı olmak istemediğini ama bunun nedeninin hiç kadın bilim insanı görmemiş olması değil, binaların yapılışının çok ilgisini çekmesi ve bu yüzden mimar olmak istemesi olarak ifade etmiştir.

2.2. Kadın Bilim İnsanı Çizen Kız Öğrencilerin Kadın Bilim İnsanı Çizmelerinin Nedenlerinin Analizi

‘Öğretmenimiz geçen hafta Newton’u anlatmıştı. Bu yüzden kadın bilim insanı çizdim.’ yanıtını veren öğrenciyle yaptığımız görüşmede, Newton’un kadın bilim insanı olduğunu düşünmesinin nedenini sorduğumda, kitaplardaki resimlerde uzun saçlı ve sakalsız olduğu için kadın bilim insanı olduğunu düşündüğünü ifade etmiştir. ‘Kadın bilim insanı çizdim çünkü çizimimdeki bilim insanı tıpkı annem gibi GDO ile mücadele ediyor. Ben, kadınların doğayı daha çok güzelleştireceğine inanıyorum.’ yanıtını veren öğrenci, yaptığımız görüşmede, annesinin akademisyen olduğunu ve uzmanlık alanının genetik mühendisliği olduğunu belirtmiştir. Annesinin bilim insanı olduğunu düşünmektedir ve kendisi de bilim insanı olmak istemektedir.

2.2. Kadın ve Erkek Bilim İnsanı Çizen Öğrencilerin Kadın ve Erkek Bilim İnsanı Çizmelerinin Nedenlerinin Analizi

‘ *Bence bu işte önemli olan zekâdır. Ben zekâ konusunda kadın ve erkeklerin birbirlerine üstün olduklarını düşünmüyorum. Kadın ve erkeklerin eşit olduğunu vurgulamak için, ekip halinde çalışan kadın ve erkek bilim insanları çizmek istedim.’ yanıtını veren kız öğrenciye (kod adı Sanem) bilim insanı olmayı isteyip istemediği sorulduğunda, polis veya sporcu olmak istediğini ama televizyonda ve kitaplarda sadece erkek bilim insanlarının gösterilmesinden rahatsız olduğunu, kadınlara haksızlık yapıldığını düşündüğünü söylemiştir. Verilen diğer yanıtları incelediğimizde ise; öğrencilerin bilim insanlarına yönelik algılarına televizyonda izledikleri programların etki ettiğini görmekteyiz. Hepsi, ‘Çünkü filmlerde, erkek bilim insanları asistanlarıyla birlikte çalışıyorlar ve asistanlarının cinsiyeti kadındır.’ yanıtını vermişlerdir. Kendisini bilim insanı olarak hayal ettiği için kadın bilim insanı çizen öğrencinin ‘Kendimi hayal ettim. Önce asistan olup, daha sonra profesör olmak istiyorum. Çizimimde, asistan olacağım dönemi çizdim. Ama asistan olduğum için, erkek bilim insanı da çizmek zorunda kaldım. Çünkü filmlerde, erkek bilim insanları asistanlarıyla birlikte çalışıyorlar ve asistanlarının cinsiyeti kadındır.’ yanıtını incelediğimizde, izlediği televizyon programlarının etkisi açıkça gözlenmektedir.

3. Bilim İnsanı Olmak İsteyen Öğrencilerin Yanıtlarının Analizi

3.1. Bilim İnsanı Olmak İsteyen Ve Erkek Bilim İnsanı Çizen Erkek Öğrencilerin Yanıtlarının Analizi

‘ *Deney yapmayı çok seviyorum.’ yanıtını veren öğrencilerden biri, ünlü olmayan, hiç kimse tarafından tanınmayan gizli bir bilim insanı olmak istediğini söylemiştir. Bunun nedenini sorulduğunda, ‘Ünlü olursam, gazeteciler beni rahat bırakmazlar; özel hayatım olmaz. Herkes her şeyimi öğrenir. Bu yüzden gizli bilim insanı olmak istiyorum.’ yanıtını vermiştir. ‘ ** Fen ve teknoloji dersi öğretmenimi örnek alıyorum.’ diyen öğrenci, fen ve teknoloji dersi öğretmenini bilim insanı olarak gördüğünü belirtmiştir ve öğretmenin cinsiyeti, kadındır. Diğer yanıtları incelediğimizde, icat yapmak için bilim insanı olmak istiyorum yanıtının frekansı çok yüksektir (N=37).

3.2. Bilim İnsanı Olmak İsteyen Ve Hem Kadın Hem de Erkek Bilim İnsanı Çizen Erkek Öğrencilerin Yanıtlarının Analizi

Bilim insanı olmak isteyen ve hem kadın hem de erkek bilim insanı çizen erkek öğrenci, zaman makinesi icat etmek istediği için bilim insanı olmak istediğini, bu yüzden kendisini hayal ederek çizim yaptığını belirtmiştir. Ardından kadın bilim insanı çizmesinin nedenini ‘Önce erkek bilim insanı çizdim çünkü kendimi hayal ettim. Daha sonra, kadın bilim insanı çizdim çünkü filmlerde, erkek bilim insanları asistanlarıyla birlikte çalışıyorlar ve asistanlarının cinsiyeti kadındır.’ şeklinde açıklamıştır.

3.3. Bilim İnsanı Olmak İsteyen Ve Erkek Bilim İnsanı Çizen Kız Öğrencilerin Yanıtlarının Analizi

Bilim insanı olmak isteyen ve erkek bilim insanı çizen kız öğrencilerde, icat yapmak için bilim insanı olma isteği ön plandadır (N=12). Bu yanıtı sırasıyla ünlü olmak istediğim için (N=7), deney yapmayı çok sevdiğim için (N=7) yanıtları takip etmektedir. Bir öğrencinin ‘Bilim insanı olup, zombiye dönüştüren virüsün geliştirilmesine engel olmak istiyorum.’ yanıtı yine görsel medyanın etkisine işaret etmektedir.

3.4. Bilim İnsanı Olmak İsteyen Ve Kadın Bilim İnsanı Çizen Kız Öğrencilerin Yanıtlarının Analizi

Bilim insanı olmak isteyen ve kadın bilim insanı çizen kız öğrenciler, gelecekte bilim insanı olmak isteme nedenlerini ‘icat yapmak için, bilimsel konular ilgisini çektiği için ve bilime katkıda bulunmak için’ olarak ifade etmişlerdir.

3.5. Bilim İnsanı Olmak İsteyen Ve Hem Kadın Hem de Erkek Bilim İnsanı Çizen Kız Öğrencilerin Yanıtlarının Analizi

Bilim insanı olmak isteyen ve hem kadın hem de erkek bilim insanı çizen kız öğrenciler, bilim insanı olmak isteme nedenlerini ‘Bilimsel konular ilgimi çekiyor. Bilimsel konuları araştırmak ve okumak, bana çok zevkli geliyor.’ ve ‘Faydalı şeyler icat ederek, insanlara yardım etmek istiyorum.’ şeklinde açıklamışlardır.

4. Bilim İnsanı Olmak İstemeyen Öğrencilerin Yanıtlarının Analizi

4.1. Bilim İnsanı Olmak İstemeyen Ve Erkek Bilim İnsanı Çizen Erkek Öğrencilerin Yanıtlarının Analizi

Bilim insanı olmak istemeyen ve erkek bilim insanı çizen erkek öğrencilerin yanıtlarını incelediğimizde, farklı bir meslek seçtiği için bilim insanı olmak istemediğini belirten erkek öğrenciler ön plandadır (N=13). Ayrıca öğretmenleri, bu öğrencilerin okul ilgilerinin yüksek olduğunu belirtmiştir. Diğer öğrencilerin yanıtlarını incelediğimizde ise, yine medyanın etkisi ön plandadır. Örneğin bir öğrenci, ‘Bilim insanı olmak istemiyorum çünkü Iron Man (Demir Adam) filminde olduğu gibi, casuslar beni kaçırıp öldürmek isteyebilirler.’ yanıtını vermiştir. Başka bir öğrenci, ‘Bilim insanı olmak istemiyorum çünkü laboratuvarında çalışmaktan eve gidemem. Laboratuvarında uyumak istemiyorum. Filmlerde de hep öyle oluyor.’ yanıtını vermiştir.

4.1. Bilim İnsanı Olmak İstemeyen Ve Erkek Bilim İnsanı Çizen Kız Öğrencilerin Yanıtlarının Analizi

Bilim insanı olmak istemeyen ve erkek bilim insanı çizen kız öğrencilerin yanıtlarını incelediğimizde, farklı bir meslek seçtiği için bilim insanı olmak istemediğini belirten kız öğrenciler ön plandadır (N=9). Ayrıca öğretmenleri, bu öğrencilerin okul ilgilerinin yüksek olduğunu belirtmiştir. Diğer öğrencilerin yanıtlarını incelediğimizde ise, öğretmenlerin ve medyanın etkisi ön plandadır. Örneğin bir öğrenci, ‘Bilim insanı olmak istemiyorum çünkü bilim insanları çalışmaktan çıldırıyorlarmış; öğretmenimiz öyle anlatmıştı. İnsanların bana deli demesi hoşuma gitmez.’ yanıtını vermiştir. Başka bir öğrenci, ‘Bilim insanı olmak istemiyorum çünkü televizyonda görmüştüm; bilim insanları asosyal oluyor. Benim bir sürü arkadaşım var. Onları kaybetmek istemem.’ yanıtını vermiştir. Ancak kız öğrencilerin kadınların bilim insanı olamayacağını düşünmeleri ve bu yüzden gelecekte bilim insanı olmak istememeleri ile ilgili hiçbir bulgu yoktur. Tam tersine, kadınların da bilim insanı olabileceklerini ama izledikleri programlarda, okudukları kitap ve dergilerde sürekli erkek bilim insanı figürleriyle karşılaşmaları yüzünden erkek bilim insanı çizdiklerini belirtmişlerdir.

Bilim insanı olmak istemeyen ve hem kadın hem de erkek bilim insanı çizen tek bir kız öğrenci (kod adı Sanem) vardır. Polis veya sporcu olmak istediği için, bilim insanı olmak istemediğini belirtmiştir.

5. Hem Kadın Hem de Erkek Bilim İnsanı Çizen ve Bilim İnsanı Olma Konusunda Kararsız Olan Öğrencilerin Yanıtlarının Analizi

		Yanıtlar	N=
Öğrenci Cinsiyeti	Kız	Hem istiyorum hem istemiyorum. İstiyorum çünkü bilim insanı olmak çok gurur verici bir şey. İstemiyorum çünkü bilim insanları deli oluyor. Televizyonda öyle gördüm.	1
		Hem istiyorum hem istemiyorum. İstiyorum çünkü ışınlama makinesi icat etmek istiyorum. İstemiyorum çünkü müzik söylemeyi de çok seviyorum. Müzisyen olmak istiyorum.	1
	Erkek	Hem istiyorum hem istemiyorum. İstiyorum çünkü kimyayı çok seviyorum. İstemiyorum çünkü deney yaparken patlama olur da ölürsem, ailem çok üzülür.	1

SONUÇ

Araştırmanın sonucunda; öğretmenlerin bilim insanları hakkında anlattığı şeylerin ve görsel ve yazılı medya tarafından oluşturulan ‘devamlı laboratuvarında çalışan asosyal ve çılgın bilim insanı’ figürünün bazı kız ve erkek öğrencilerin gelecekte bilim insanı olmak istememelerine neden olduğu anlaşılmıştır. Ancak bu çalışmadan elde edilen bulgular, literatürde yer alan ‘kız öğrencilerin bilim insanı çizerken çoğunlukla erkek bilim insanı çizmeyi tercih etmelerinin, kız öğrencilerin kadınların bilim insanı olamayacağını düşünmelerinden ve bu yüzden gelecekte

bilim insanı olmak istemediklerinden kaynaklandığı' iddiasını çürütmektedir. Ancak bu konuyla ilgili, boylamsal çalışmaların yapılmasına ihtiyaç vardır.

KAYNAKLAR

Chambers, D. W. (1983). Stereotypic images of the scientist: The Draw-A-Scientist Test, *Science Education*, 67 (2), 255-265.

Fung, Yvonne, Y. H. (2002). A comparative study of primary and secondary school students' images of scientists, *Research in Science & Technological Education*, 20 (2), 199-213.

Kaya, N. O., Doğan, A., Öcal, E. (2008). Turkish elementary school students' images of scientists, *Eurasian Journal of Educational Research*, 32, 83-100.

Mc Comas, W.F. (2002). *The Nature of Science (NOS) in Science Education; Rationales and Strategies* (pp.11-30). New York: Kluwer Academic Publishers.

Mead, M., Metraux, R. (1957). The image of the scientist among high school students: a pilot study, *American Association for the Advancement of Science (AAAS)*, 126 (3270), 384-390.

Moeller Andersen, Hanne & Krough, Lars Brian & Lykkegaard, Eva (2013). Identity matching to scientists: Differences that make a difference?. *Research In Science Education*. doi:10.1007/s11165-013-9391-9.

Losh, S. C, Wilke, R., Pop, M. (2008). *Some methodological issues with "Draw a Scientist Tests" among young children*, *International Journal of Science Education*, 30(6), 773-792.

Steinke, J. ve diğerleri. (2007). Assessing media influences on middle school-aged children's perceptions of women in science using the draw-a-scientist test (DAST), *Science Communication*, 29(1), 35-64.

TEACHING THE SCIENTIFIC EXPLAINING CONCEPT THROUGH “SOCIO-CULTURAL DIALECTIC METHOD” IN SCIENCE COURSES

Emre Harun KARAASLAN
Gaziantep Üniversitesi Naci Topçuoğlu Meslek Yüksekokulu
ehkaraaslan@gantep.edu.tr

Yılmaz SAĞLAM
Gaziantep Üniversitesi Eğitim Fakültesi
ysaglam@gantep.edu.tr

ABSTRACT: One of the basic function of the science is explaining the phenomenon, concept, and occasions in a scientific point of view (Türkmen ve Yalçın, 2001). Scientist has been trying to explain not only “whys” but also “in which situation” and “how” in the framework of reason-result relationship (Rudolph ve Steward, 1998; Yaşar, 1998). When considered from this point, it is essential to state why and how the phenomenon, concept, and occasions to be explained has occurred. Because of this reason, in the researches that has been done recently related with science education, it has been put emphasis on teaching how the explanations of events and occasions taking place around us are made (Osborne and Dillon, 2008). Moreover, it was stressed in not only international reports related with education (American Association for the Advancement of Science [AAAS], 2009; National Research Council [NRC], 1996) but also in national curriculums (MEB, 2007; 2013) that instead of giving simple answer to the questions asked students in science education, it is necessary for students to gain the ability of scientific explanation that students make broader explanations. However, it was found that students in our country are inadequate about making scientific explanations. When evaluated from this point of views, in the teaching and learning activities that take place at schools, it comes into prominence that the idea of using some techniques in order to develop students’ skills to explain the scientific concepts. Initially, to improve students’ ability to make scientific explanation, it can be said that what the scientific explanation is must be taught to them. From this point, it is thought that socio-cultural dialectic method might be effective in teaching the concept of scientific explanation. Socio-cultural dialectic method, claiming that to form theoretical concepts in the mind not only the interaction with the environment but also presenting the new perspectives to individuals by experienced people is necessary, consists of three dimensions; *context*, *contextual action*, and *labelling*. The aim of present study is introducing socio-cultural dialectic method and discussing how to teach the concept of scientific explanation by using this method.

Key words: scientific explanation, socio-cultural dialectic method, teaching concepts

ÜÇ AŞAMALI YÜZME-BATMA TANI TESTİNİN GELİŞTİRİLMESİ

Developing a three tier diagnostic test related with sinking and floating

S.Ahmet KIRAY
Necmettin Erbakan University
ahmetkiray@gmail.com

Hamza KAYNAR
Necmettin Erbakan University

Sena KILINÇ
Necmettin Erbakan University

Tuğçe GÖRKEMLİ
Necmettin Erbakan University

ÖZET: Öğrencilerin yaygın kavram yanlışlarına sahip olduğu konulardan bir tanesi de yüzme-batma konusudur. Bu nedenle bu araştırmada öğretmen adaylarının yüzme-batma konusundaki kavram yanlışlarını ortaya çıkartmak için bir ölçme aracı geliştirmek amaçlanmıştır. Bu amaçla Türkiye deki iki üniversitenin fen bilgisi öğretmenliği anabilim dalında öğrenim gören 400 öğrenciye uygulanmıştır. Üç aşamalı tanı testi şeklinde geliştirilen ölçme aracının geçerliliği faktör analizi, false pozitif, false negatif değerleri arasındaki korelasyon katsayı hesaplanarak ve uzman görüşü alınarak sağlanmıştır. Ölçme aracının KR-20 güvenirlik katsayısı 0,71 olarak hesaplanmıştır.

Anahtar kelimeler: yüzme-batma, yoğunluk, basınç, kaldırma kuvveti

ABSTRACT: One of the subjects in which students have common misconceptions is the floating and sinking. For this reason, this study is aimed to develop a measurement instrument to reveal preservice teachers' misconceptions about sinking and floating. The test developed for this purpose was applied to 400 preservice science teachers at two universities in Turkey. The reliability of measurement instrument developed as a three tier test was provided by factor analysis statistics, calculating false positive and false negative correlation coefficient. Also, two experts reviewed the test. The KR-20 reliability coefficient of the pre-service teachers' scores was calculated and found to be 0,71.

Key words: Floating and sinking, pressure, buoyancy, density

BAYES RISK FOR SELECTION THE MEDIAN CATEGORY FROM EVEN SAMPLE SIZE IN K-NOMIAL DISTRIBUTION

Kawther HAMZA

Bayes risk procedure is proposed for selecting the median (middle most value) in multinomial cell when the number of observation is even. Bayesian decision –theoretic approach with linear loss function and conjunction prior Dirichlet distribution is used to construct this procedure for it we need to deriving . Some concluding remarks and suggestions for future work are also included.

Keywords: bayesian procedure ,ranking and selection approach ,medain

LITERATURE ON META-ANALYSIS METHOD

Ayse KOK

Ismail SAHIN

Literatüre kazandırılan her yeni çalışma; kuşkusuz, alanına hizmet etmekte ve bilimin ilerlemesine katkıda bulunmaktadır. Ancak, herhangi bir konuda yargıya varmak için tek bir çalışma sonucuna güvenmek bizi yanıltabilir. Farklı koşullarda, farklı ortamlarda ve farklı zamanlarda yapılmış çok sayıdaki çalışma sonuçlarının birleştirilmesi daha geçerli ve güvenilir sonuçlar verecektir. Bugüne kadar araştırmaların sentezlenmesinde literatür derlemeleri ve oy sayma tekniği gibi istatistiksel olmayan çeşitli yöntemler kullanılmıştır. Son yıllarda giderek yaygınlaşan meta-analiz yöntemi bu alanda önemli bir boşluğu doldurmaktadır. Meta- analizi, belirli bir konuda yapılmış, birbirinden bağımsız, birden çok çalışmanın sonuçlarını birleştirme ve elde edilen araştırma bulgularının istatistiksel analizini yapma yöntemidir. Meta- analiz diğer analizlerin analizidir. Daha önce yapılmış çalışmalardan elde edilen özet niteliğindeki verileri, nicel yöntemler kullanarak birleştirir. Bu çalışmanın amacı meta-analiz yöntemi hakkında bilgi vermektir. Bu kapsamda; etki büyüklüğü, istatistiksel model seçimi, meta-analiz türleri, kullanılan tablo ve grafiklerle ilgili yorumlamalar gibi meta-analizle ilgili temel konulara değinilecektir. Bu sayede bir meta-analiz çalışmasının; yürütülmesi, raporlanması ve yapılmış bir meta-analiz çalışmasının değerlendirilmesi aşamalarında ışık tutacağı düşünülmektedir.

Anahtar Kelimeler: Meta-analysis, literature review, systematic review

ÖZEL GEREKSİNİMLİ BİREYLERİN EĞİTİMİNDE BİLGİ İLETİŞİM TEKNOLOJİLERİNİN KULLANIMI

Arş. Gör. Kürşat ÖĞÜLMÜŞ

Konya NEÜ Ahmet Keleşoğlu Eğitim Fakültesi, Özel Eğitim Bölümü Araştırma Görevlisi.
kursatogulmus@hotmail.com

Arş. Gör. Nevzat ULUTEPE

Konya NEÜ Ahmet Keleşoğlu Eğitim Fakültesi, Özel Eğitim Bölümü Araştırma Görevlisi.
newzat-ulutepe@hotmail.com

Ülkemizde 2012 yılında yapılan eğitim reformundan sonra her alanda olduğu gibi özel eğitim alanında da teknoloji tabanlı uygulamalarının çoğaldığını ve hızlandığını görmek olasıdır. Günlük yaşam alanlarında bireylerin hayati ihtiyaçlarını karşılamada büyük kolaylık sağlayan bilgi iletişim teknolojileri eğitimcilerin işlerini de oldukça kolaylaştırmaktadır. Normal gelişim gösteren bireylerde kullanılan bilgi iletişim teknolojileri (ICT) aynı zamanda özel gereksinimli bireyler için de kullanılmaktadır. Ancak özel gereksinimli bireylerin eğitiminde bu teknolojilerin etkin kullanılabilmesi için ortam düzenlemeleri ile ilgili uyarlamaların yapılması gerekmektedir. Özel eğitim alanında çalışanların çoğu teknoloji destekli uyarlamalar yapmayı tercih ederken teknoloji destekli uygulamaların her geçen gün özel eğitim alanında kullanım oranının arttığı gözlenmektedir. Teknoloji temelli uygulamalar bireysel farklılıklara göre planlanan programlarındaki eğitim süreçlerinin yapılandırılmasına önemli katkılar sağlamaktadır. Teknoloji destekli uygulamalar aynı zamanda değerlendirme ve yönetim süreçlerinde de katkı sağlamaktadır. Ancak ülkemizde özel eğitim kurumlarındaki öğretim süreçleriyle ilgili etkinliklerde bilgi iletişim teknolojilerinin beklendiği düzeyde kullanılmadığı gözlenmektedir. Dolayısıyla bu çalışmanın amacı; 1) özel gereksinimli bireylerin eğitiminde kullanılan mevcut bilgi iletişim teknolojilerinin kullanılmasıyla ilgili stratejileri ve önemini ne olduğunu belirlemek ve 2) bu alanda yapılacak araştırmalara kuramsal bilgi sağlamaktır. Bu araştırma kaynak tarama yöntemi kullanılarak tamamlanmıştır.

Anahtar Kelimeler: Özel Eğitimde Kullanılan Bilgi İletişim Teknolojileri, Teknoloji Destekli Özel Eğitim Uygulamaları, Etkili Özel Eğitim Uygulamaları

USE OF INFORMATION COMMUNICATION TECHNOLOGIES (ICT) IN EDUCATION OF INDIVIDUALS WITH SPECIAL NEEDS

Arş. Gör. Kürşat ÖĞÜLMÜŞ

Konya NEÜ Ahmet Keleşoğlu Eğitim Fakültesi, Özel Eğitim Bölümü Araştırma Görevlisi.
kursatogulmus@hotmail.com

Arş. Gör. Nevzat ULUTEPE

Konya NEÜ Ahmet Keleşoğlu Eğitim Fakültesi, Özel Eğitim Bölümü Araştırma Görevlisi.
newzat-ulutepe@hotmail.com

In our country, after the Educational Reform in 2012, technology -based applications has accelerated in special education as it is in every field of education. Information and communication technologies (ICT) which ease the daily life of individuals also ease the educators' job. ICT used in individuals with normal development is also used for individuals with special needs. However, for effective usage of these technologies individuals with special needs, some environment adaptations should be made. More and more teachers in the field of special education prefer technology-based applications day by day. Technology-based applications prepared according to the individual differences provide important contributions for structuring the educational process. Technology - based applications also contributes the process of evaluation and management. But, in our country the usage of information and communication technologies in special education are limited. Hence the aims of this study is; 1) to determine the existing information and communication technologies and important strategies used in the education of individuals with special needs and 2) to provide theoretical knowledge for further researches in this area. This research was completed by using literature review method.

Keywords: Information Communication Technologies Used in Special Education, Technology Assisted Special Education Practices, Effective Special Education Practices

OTİZMLİ BİREYLERİN EĞİTİMİNDE KULLANILAN TABLET UYGULAMALARI

Arş. Gör. Kürşat ÖĞÜLMÜŞ

Konya NEÜ Ahmet Keleşoğlu Eğitim Fakültesi, Özel Eğitim Bölümü Araştırma Görevlisi.
Email: kursatogulmus@hotmail.com

Arş. Gör. Nevzat ULUTEPE

Konya NEÜ Ahmet Keleşoğlu Eğitim Fakültesi, Özel Eğitim Bölümü Araştırma Görevlisi.
Email: newzat-ulutepe@hotmail.com

Otizimli bireylerin eğitim sürecini daha işlevsel hale getirmek amacıyla bazı yardımcı teknolojiler kullanılmaktadır. Bunlardan en yaygın olarak kullanılanlardan biri de tablet bilgisayarlarda kullanılabilen eğitim uygulamalarıdır. Uluslararası düzeyde özellikle otizimli bireylerin eğitiminde oldukça yaygın kullanım alanlarına sahip olan bu uygulamalar ülkemizde her geçen gün daha da yaygınlık kazanmaktadır. İlgili alanyazını incelendiğinde görsel ve işitsel öğelerin eğitim sürecinde kullanıldığı zaman daha işlevsel davranış değişikliklerine sebep olduğu ile ilgili çalışmalar mevcuttur. Ancak ülkemizde otizimli bireylerin eğitiminde kullanılan tablet uygulamalarıyla ilgili çalışmaların sınırlı düzeyde olduğu görülmektedir. Bu çalışmanın amacı; 1) Otizimli bireylerin eğitiminde kullanılan tablet uygulamalarının kullanım alanlarının belirlenmesi ve 2) mevcut uygulamaların derlenerek özel eğitim öğretmenlerinin kullanımına sunulmasıdır.

Anahtar Kelimeler: Otizm, Otizmde Kullanılan Tablet Uygulamaları, Yardımcı Teknolojiler

TABLET APPLICATIONS USED IN EDUCATION OF INDIVIDUALS WITH AUTISM

Arş. Gör. Kürşat ÖĞÜLMÜŞ

Konya NEÜ Ahmet Keleşoğlu Eğitim Fakültesi, Özel Eğitim Bölümü Araştırma Görevlisi.
kursatogulmus@hotmail.com

Arş. Gör. Nevzat ULUTEPE

Konya NEÜ Ahmet Keleşoğlu Eğitim Fakültesi, Özel Eğitim Bölümü Araştırma Görevlisi.
newzat-ulutepe@hotmail.com

Some assistive technologies are being used in order to make the education process of individuals with autism more functional. One of the most widely used is tablet applications designed for educational purposes for individuals with autism. At the international level, especially in the education of individuals with autism these applications are quite common. In our country it is becoming increasingly more widespread. When the related literature analyzed, it is seen that the audio-visual images used in the educational processes is more functional than other methods. However, this kind of technologies seems to be limited in our country. The purpose of this study is; 1) to identify the usage areas of tablet applications for individuals with autism and 2) to compile the existing applications for the use of special education teachers.

Keywords: Autism, Tablet Applications Used in Autism, Assistive Technologie

DESIGNING OF A CNC TRAINING SET

Res. Asst. Selahattin ALAN¹

Selçuk University, Technical Education Faculty, Department of Electronics and Computer Education
salan@selcuk.edu.tr

Prof. Dr. Faruk ÜNSAÇAR

Selçuk University, Technical Education Faculty, Department of Electronics and Computer Education
funsacar@selcuk.edu.tr

ABSTRACT: Computer Numerical Control (CNC) is a system in where computer numerical control codes determine machining and sizing process of a work piece. Today, most of the products in manufacturing sector are produced by CNC lathes. Therefore, CNC lathes are indispensable parts of the manufacturing sector. In order to bring up operators who use CNC lathes, related courses are offered in our educational institutes. In different vocational high schools, faculties and vocational college, some knowledge such as basic lathe system, lathe usage, lathe programming, way of thinking three dimensional and work piece machining are offered to students who are candidates of being employed in this sector with the aim of reliable, effective and correct usage of these sensitive lathes that are so important for manufacturing. But, these learnings will be permanent and education will reach the target if and only if theoretical knowledge is followed by practical training session. In this study a training set that is low-cost, completely prepared in Turkish and educational has been designed and manufactured (produced) for the students who are getting CNC education. Training set consists of an electronics book that includes theoretical knowledge, a multimedia environment that includes usage, programming and structure of CNC, an editor that is used as programming environment, a simulation environment where written program's results can be viewed and a mini CNC lathe which has same functionality of original lathe and has the capability of processing work piece. Combination of all these materials made up training set and let the student to see the work piece from draft to production.

Key words: CNC, Computer Based Numerical Control, Training Set, CNC Machine Training

INTRODUCTION

Metal parts of the many tools and machines we use in our daily life have been manufactured through metal cutting processes such as turning, milling and drilling. Producing manufactured products, which we use so frequently in every parts of our life, makes this sector one of the most important sectors operating in the industry. Because of its importance, this sector has to renew itself parallelly to other sectors and development of the technology.

Especially turning, milling and drilling are frequently used processes in manufacturing operations. These operations are performed by using turning, milling and drilling machines. Conventional machines which were used in past are still used in some areas, but today, in general, computer controlled machines have replaced them. The use of Numerical Control (NC) and Computer Numerical Control (CNC) machines has become fairly widespread parallelly to developments witnessed in 20th century.

Thanks to their some features such as high cutting and drilling capacities, high speed, precise and productive operating properties; CNC machines have become indispensable elements of the sector. These machines' being so popular in the industry has brought a demand for qualified employee. Because, while a basic level of turning and milling training is enough for conventional machine operators, and it can be learnt through master-apprentice relationship, for CNC operators beside these basic skills; some higher level skills such as basic computer knowledge, CNC code reading, writing and interpreting skills are required. When the conditions such as diversity, size, sensitivity and the high cost of machines are considered qualified employees gain more importance.

The most important places in which employees can acquire knowledge and skills to use these machines are; CNC departments of Anatolian Technical High Schools, Anatolian Vocational High Schools, Industrial Vocational High Schools and Technical High Schools in high school level, and graduate schools and vocational schools in higher education level.

With this study; a CNC training set will be introduced for institutions and organizations who aims to give in-service training to their employees to help them to enhance their knowledge and skills .For CNC training in training courses; CNC machines or costly foreign origin CNC training sets have been used. A minor mistake

¹ Bu çalışma ilk yazarın yüksek lisans tezinden üretilmiştir.

that an operator may do may cause great troubles, and this situation may put training institutions into trouble about repairment and replacement of the machines which are hard to be owned because of their high costs.

Within the scope of the designed CNC training set, there is an electronic book media by which theoretical information on use of the machines and their programming can be acquired, and there is an editorial environment in which tentative programme codes can be written and there is also a simulation media on which a simulation of a prepared simulation can be seen. Thanks to this training set; training institutions will have an opportunity to have a complete training set which is cheap, made in our own country, enables individual learning and covers all environments required all in one for CNC training.

EDUCATION - TRAINING AND TECHNOLOGY

Erturk, (1979) states that education is individual's practicing voluntary behavior process through his own life intentionally. With respect to this definition there are three main characteristics of education. First; behaviors of an individual must be modified in the intended direction, secondly, behavior modification occurs through individual's own experiences (as a result of coordinated knowledge and communication with the environment), and third, education is a planned and programmed process (Özdemir & Yalın, 1999). As it is clearly seen, the most emphasized point in education is behavior modification. If behavior modification takes place in the intended direction it means education is successful.

Education is not only limited to school and school periods, it continues at any time and every aspects of life. Everything a human being does in his life brings him knowledge, experience, change in attitude and behavior, and this makes some changes on him. In short, as some behavioral changes can be achieved through education process, in order to educate people in the direction of desirable qualifications people are required to have experiences that provide desired properties them, and by this way some behavioral changes must be achieved.

A society which consists of educated people means a society with high workforce level and a better society. In the society formed on which education is applied in various areas almost all sections of the society need for education in order to step forward. For institutions and organizations which aim to get into competition technically, economically, socially and commercially, and want to be the best providing adequate and high quality education has become a necessity.

Every individual, institution and organization who comprehends the importance of education minds not only how technical knowledge or product is important but also how education on these products and the profit they will have are important. Today, in purchasing process of the best machines, programs and technical devices that are produced, people don't only search for their uses and functions; they also search if they can make use of it with its educative way and the technical support that will be taken in the use of these products. All of these mentioned above present the importance education.

Technology that brings great conveniences to all areas of our lives and that serves as a bridge between practice and science also brings great conveniences in the area of education. The educational technology including all aspects of human learning case, systematically analyze problems, all the relevant elements to develop their solutions (manpower, information, methods, techniques, tools, editing, etc.) is the work that is developed by running the appropriate designs, implements, evaluates and manages a complex process (Yalın, 2004).

One of the largest reflections in educational technology is also the use of computers. The computer, due to the high initial cost of purchasing, even though it seems a little expensive for education to keep the students active, to provide student-centered education, to present the information in the required format, when all of these are taken into account is an affordable training tool in the long term. Thanks to computers and educational software specially designed for educational purposes in education, in order to make an effective education the required principles can be applied more easily.

MACHINE TOOLS AND CNC

Obtaining as raw material in a desired shape, form and appearances to obtain a suitable material in the means of production used is called machine tools. By machine tools especially metal, wood, plastic and other materials and marble can be processed. Raw materials that are fastened to the machine tools for the purpose of the counter, task, and the function and thanks to the moves of transactions in certain parts of the machine tools pass through a series of operations. The manufacturing that will be made through these lathes is divided into two as with sawdust and without sawdust. Manufacturing with sawdust from the work piece surface gets its name it's being made through lifting. The process of turning, milling, drilling, shaping, broaching, grinding, honing, lapping is made in the sawdust manufacturing process, on the other hand casting, forging, pressing, rolling, drawing, extrusion, bending, welding, gluing, soldering is made in without sawdust manufacturing process. The

common feature of all these processes is based on the trio of team piece and the process. Generally, in the past the without sawdust manufacturing process was used but today mostly the sawdust manufacturing process has been used.

For Soysal (1991), the first appearance of the machine tools goes back to the 16th century. In 1540, an Italian called Torriano, in the manufacture of a clock that would be presented to the Spanish King Charles V, has used the first sample of milling machine. This machine consisted of an adjustable cutting rotary index table with a hole cutter. The ancestor of modern machines is taught to be used in 1775 by John Wilkinson as a horizontal boring machine. The first turning machine was made around 1780s by Henry Maudstay (Özdeveci, 2001).

In line with technological developments to improve the quality of machines, to ensure easier reproducibility, low cost and in order to replace easier working conditions, it was automated. Thus, the part of the processing of the information data after they were operated given by the human made conventional lathes, was found out that the data were composed of the numerical program code that the lathes can understand.

The Numerical Control (NC) can be named such: to control a movement of numerically, to control a movement numerically or in other words, according to a particular number system to control a system of coded input signal and the implementation to the appropriate logic and finally the desired output is achieved according to the commands within a tolerance (Koçlu, 2002). NC is written to the control unit according to the features of the desired part to be produced and the shape of the piece. In line with the data on the lathe the move command is sent to the active pieces and making the parts that are needed active the pieces are processed. Again, in line with technological developments, with the introduction of computers in our lives, as a result of the integration with the computer program code storage on NC lathes, CNC came into being (Computer Numerical Control). The CNC lathe is a machine that composes certain letters, numbers, symbols and that is connected to the counter depending on the encoded commands to a particular logic. Working with the CNC lathes in the various stages of the metalworking methods has great advantages. In parallel with the development of technology, the structure of the CNC lathes has increasingly developed and begun to be used in different areas. Generally, today the CNC lathes are manufactured and being used. Even in small numbers, the conventional lathes have been used and manufactured.

The CNC lathes, through the integration of control unit of the lathe with the computer, along with the programs stored in memory it is possible that the software stops at every stage of piece manufacturing, may be necessary to make changes in the program, to continue the program again from thick, and it is also possible to be able to keep the program in memory with the final form. Thus, once installed the program control unit is sufficient. The transfer of the program to the lathes can be in two ways, one is via the vertical panels and the other is the codes can be produced on the computer and the digitized data through a cable (Dinçel, 1999).

In today's world the CNC is being used in the area of industrial manufacturing sawdust. Today's CNC was emerged as a result of the problems that are encountered in this field mentioned above. When three-axis milling lathe was first operated in 1952, it was perfect as providing the solution of that day's some manufacturing problems. Those systems applied to the lathes was later also applied to turning and grinding lathes. Today, CNC has been used in almost every field of manufacturing facilities (Dinçel, 1999). CNC technology has been used in some areas such as; lathes, milling machines, drilling and grinding machine tools, measuring machines and tools, bending-bending machines, pipe bending machines, shaping machines, welding machines, dyeing machines, woodworking machines, drawing machines.

The primary and the biggest benefit of CNC lathe is its allowing automation. By the use of CNC machines, the intervention of the operator during the manufacture of the work pieces can be minimized or eliminated completely. During machining process, most CNC machine tools can operate without of any outside intervention, so that the operator has a chance to find time to deal with other works. This enables CNC operator to minimize his errors, and minimize errors caused by human being, machining time to be determined in advance and completely. Since the machine will be running under program control, when compared with the operator of a conventional machine who made the same parts, the level of basic skill experience of CNC operators are considerably reduced (Mamur, 2005).

The second major benefit of CNC technology, sensitive parts of the business come out equally and are constantly. Today's CNC lathes have incredible positioning and repeat capacities. This case, after the program has been checked; enables two, or ten thousand in the work piece to work in the same precision and dimensional accuracy (Mamur, 2005). Moreover, when compared with other lathes it can save the data and consistently write programs (even if the electricity goes off, will not be affected) can be stored in lathes' memory, later can be used at any time was called back. Adjusting these lathes in the program and adding new information process is very easy. Thanks to the sub programs, the programs used mostly are always with you. The calculation process of compensation values is made automatically by the lathe, and this provides a number of advantages. Thanks to

the simulation appears on the screen of the program, the operator is able to have information momentarily about the operations performed. Being able to find out the faults of the lathes can be found out in the control is another advantage of the lathe. Automatic changing cutters provide users with great amenities. Thanks to the memory of the lathe can be accessed by an external computer, the users are able to send the programs directly to the lathe, and use the program in a different computer.

CNC TRAINING

The CNC training in Turkey in high school level has been taught in Anatolian Technical High School, Anatolian Vocational High School, the Vocational and Technical High School and the School at tertiary level and in vocational schools. The CNC departments of these schools have CNC courses and on the other hand it has been also taught in other departments.

The CNC courses taught in high school level to vocational and technical schools are such in the following due to small difference.

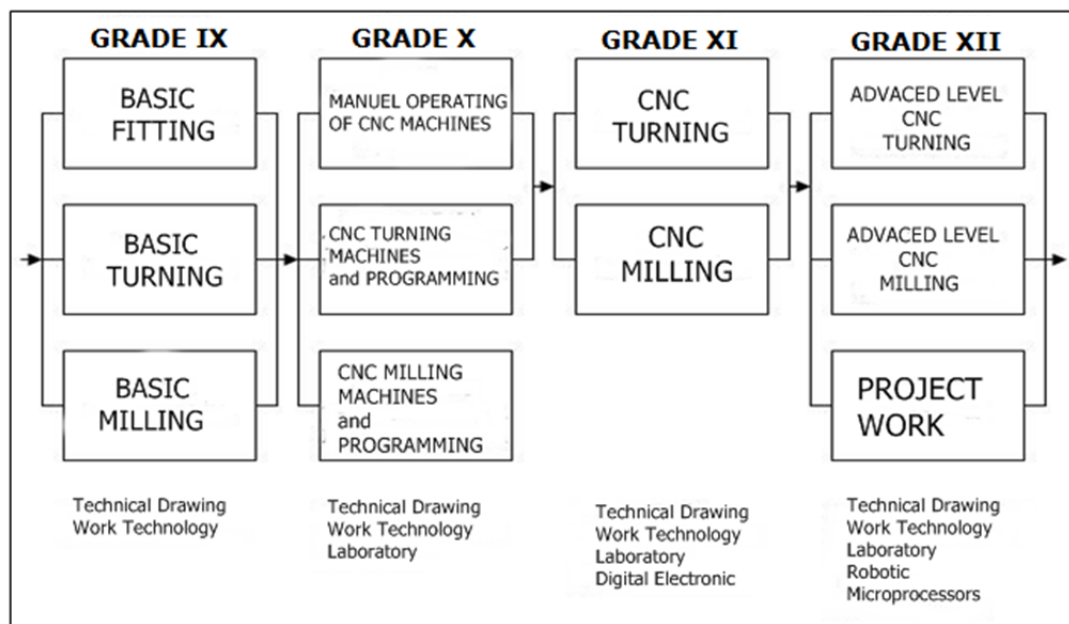

Figure 5: Numerical Control (CNC) Course Modular Program Structure (MEB, 1996)

Moreover, in the following departments the CNC courses have been taught: Hydraulic and Pneumatic Technology Department, Mold Division, Department of Mechanical, Micro technology Department of Mechanical Model Department, Furniture-Interior Department, Wooden Boat Building Division, Department of Plastic Arts, Shoes Department of Computer Aided Industrial Modeling Department, Industrial Casting Department and Leveling Department of Plastic Processing Department. In the table below there is given the name of the courses that are related with the CNC course which are taught in vocational and technical education in high schools connected to the Ministry of Education.

The CNC training, as seen in our country has been given in many educational institutions. To make the training more qualified given in this course, each step that will be taken concerns thousands of students studying in these schools and the teachers. So, thousands of students and teachers are affected by the CNC training. In order to get a better quality education of the students, the self-supporting and facilitating the work of teachers with training materials, and by using the modern teaching methods, in terms of quality personnel it is important train graduates that it will serve the country's industry.

To be able to remain standing today and create employment is only possible with competitive strength. One of the main economic indicators of competitiveness is efficiency. The most important factor that increases the productivity undoubtedly is the educated workforce. Education is an important need to be there today. Education, industry and service sector increases the efficiency and effectiveness; increases the employability of the workforce. The industrial organizations who are aware of this situation, they organize courses to improve the efficiency and effectiveness of the employees such training in various courses.

The CNC lathes can be used in many different sector of industry such as, aerospace, automotive, bottle and glass, molding, modeling, shoes, jewelry, souvenirs, coins and badges, health, rapid prototyping, billboards,

white goods and toys. And there are thousands of personnel working in these sectors. Number of people are earning thanks to CNC machines. Every business that operates in this sector has lower costs compared to the others, is in the efforts to provide better service. For this reason, every business needs a more knowledgeable and experienced staff on the CNC or is willing to provide training to staff on hand.

For example, there are only about 10,000 CNC machines in Konya. The staffs using these lathes and business owners who have these lathes are affected by the related facilities. Therefore, the development of new methods for the training of CNC machines the search of opportunity is important for many people working in the industry.

MATERIAL AND METHOD

Taking the benefits CNC provides to the industry and the present situation of CNC Trainings in our country into consideration, it was concluded that design and production of a CNC Training Set will be a profitable endeavor. The design and production logic of the CNC Training Set is based on the fact that the learning process of CNC usage is similar to that of driving an automobile. Just like a person who wishes to learn to drive first receives theoretical (structure and working process of the engine, units that constitute the automobile, systems of the vehicle, etc.) and practical information (rules to be followed at traffic, meanings of traffic warning signs, necessary deeds to ensure a safe drive etc.) and then proceeds to practice at an appropriate field with an accompanying driving trainer; a person who wishes to be knowledgeable of CNC usage should first receive theory and then exercise it. Note that a driver candidate is due to trainer's control during the practice; if s/he happens to make a mistake the mentor is there to intervene. The intervention gradually lifts as the driver candidate progresses at practice. After a certain amount of time taken for exercise, the driver candidate becomes an actual driver; able to use the automobile by him/herself. Teaching on another hand, is neither an easy job. Teaching how to use a CNC is moreover a hard work since a CNC machine is a mechanism formed of various systems, some of which are interconnected while some others are totally independent. Each of these systems, the 'metabolism' of the machine in operation, how it can be controlled, how a workpiece should be put into process, how the programming should be made are all to be taught to the learner. In order for the information to permanently settle in student's mind and become applicable, theory should be supported by practice. Let alone the rest of the education, teaching how to write a compatible program is quite a difficult work itself since a dense crowd of resembling codes are due to creating contradiction in terms. Writing the program therefore holds a specific part in the training; bearing a particularly complicated character, program writing requires a distinct amount of time to practice. The teaching model at driving courses is taken as basis in preparation of the CNC Training Set since the learning process of CNC usage is similar to that of driving. Taking these necessities of the particular learning process of CNC Usage into consideration, the Set was developed on the base of respective educational principles. A teaching method in which practical lessons are in correspondence with basic learning rules was followed.

CNC Training Set is designed as a desktop training package that aims to ensure a more efficient CNC training and enables all CNC-related processes to be exercised on the same media. The Set is made up of two main sections, software and hardware section. The hardware section constitutes of a mini-CNC machine. Set up in Turkish, this mini-machine is an ordinary CNC, only with smaller dimensions. The software part meanwhile, consists of programs that are meant to operate in a specific computer which will be placed in the hardware part. The software body includes an interface that lets the user to reach any information regarding the CNC and the production process. The interface also enables access to sub-sections. By clicking the links or buttons on this interface; the user can reach various sections such as the e-book, the multimedia-supported narration or the simulation; each of which are rich in content. Below is a list of features that are ready to function at the CNC Training Set:

1. The screen enables the user to study CNC programming commands. User can summon detailed information pertaining to these commands and see relevant examples. Therefore, any time the user wishes to review or consolidate his knowledge on programming commands, he will have ready service with this Set.
2. The user can follow audio and video records where machine components, working principles and general information on CNC usage are explained in detail by a professional.
3. Programming codes can be entered through the panel. A real-time simulation of the production can be summoned to the screen. All changing values, the process that will operate on basis of the entered codes and the eventual shape that the workpiece will take can all be watched at the simulation.

As soon as the hardware section is added to the Set, which is set to happen in a short period, below functions will also be applicable:

1. The user will be able to connect a real workpiece to the machine. In other words, an actual production will be possible. Witnessing the production stages, seeing the functions of the machine throughout the process and observing the mechanical movements conducted by these functions will all be achieved with the joining of the hardware section.

2. The machine's user-friendly ergonomics will enable the user to easily control the CNC process through a control panel which will be right next to him. The user will have the chance to intervene from where he sits.

Learning how to use a CNC Machine is a multi-staged process. Theoretical information on the machine should first be obtained. Then programming should be learned and the learner should write programs. This is essential because in this stage the learner receives the chance to see the mistakes he is inclined to make during formatting the machine. The corrected program should then be entered to instruct the CNC. Eventually, the workpiece should be connected to the machine and the program should start to run for the candidate operator to watch and learn. This particular CNC Training Set does contain sections which sequentially follow these stages. The learner first receives theoretical information from the information screen; that is general information on the CNC and the command structures. He then proceeds to program writing; this stage is accompanied by simulation. The simulation helps him to see if he has made any mistakes and if any, to correct them. As mentioned before however, the hardware section through which a real application on the workpiece can be made is not materialized and added in the Training Set yet, due to high costs. Subsections of the software section are shown and explained below.



Figure 6: Interface of the Software

Electronic Book Section: This part of the software is prepared as an e-book where the user can reach theoretical information. From machine programming commands to utilization types, all sorts of information regarding CNC usage can be found in this part. As a topic is selected from the list on the left hand side, its content displays on the right. The menu is prepared in shape of a concept map with a tree-like appearance, this enables easy access to the requested topic from anywhere in the media. CNC Machines, Basic CNC Codes, Operational Codes, Computer Supported Piece Programming and Direct Numeric Control are the topics that are explained in this section.

Multimedia-Supported Explanatory Section: This is a multimedia (vocal and visual) supported environment where various titles such as parts, systems or segments of the CNC Machine or usage of the control panel are lectured by a professional operator. The narration can both be listened and watched through a video that displays on the screen. The multimedia environment consists of ten episodes, namely “CNC Machines from Programmer's View”, “Information on Writing Basic CNC Programs”, “Movement Types”, “Compensation Types”, “Structure of a CNC Program”, “Features to Contribute Programming”, “CNC Machines from Operator's View”, “Machine Process Modes”, “Procedures” and “Principles of Writing a Safe Program”.

Simulation Section: This is the part where the written program codes can be simulated into a virtual manufacturing process. The user is therefore able to see how the process will look like once he passes on to actual production. This environment includes an editor program with which the user writes program codes. A simulation of the production is displayed on the screen, enabling the user to observe the phases of the operation through which the workpiece is processed towards its planned shape. At this section, a new program can be written, the written ones can be saved to computer's memory, and if any, previously saved programs can be summoned and edited. Program codes are written with an on-screen keyboard. Use of an external keyboard has been avoided deliberately with respect to the goal of ensuring the simulation to be wholly realistic.

As “Show Simulation” button is clicked after the completion of coding, a particular simulation program initializes. The written program shall then open within this simulation program. Clicking on “Show Simulation” enables the user to review various values of the planned production before the actual commencement of the process: What form shall the workpiece take on basis of the written program codes, which tools shall be used, how the workpiece shall be processed, which steps will be followed during processing. These will all be available to reviewing at the simulation. If a mistake that sources from the written programme is noticed during the simulation, the software warns the user on the type of the error. The user will have the means to see the error of the written program and correct it before writing the code on an actual CNC Machine.

It has not been deemed necessary to write an original program for the simulation part since several simulation programs are available and accessible on the internet. A free software called CNC Simulator 4.44f from Microtech company is used in this project. The software simulates the workpiece according to the commands that are written in pursuance with the standard ISO (International Organization for Standardization) codes.

Mini CNC Lathe Section: Due to cost-related reasons, all designed sections of the CNC Training Set are yet to complete. It is planned to complete the rest of the design by conceptualizing the unfinished sections and obtaining financial support for those. The Mini CNC Lathe will take Fanuc Machine system as basis and work with the codes given in pursuance with ISO (International Organization for Standardization) Standards.

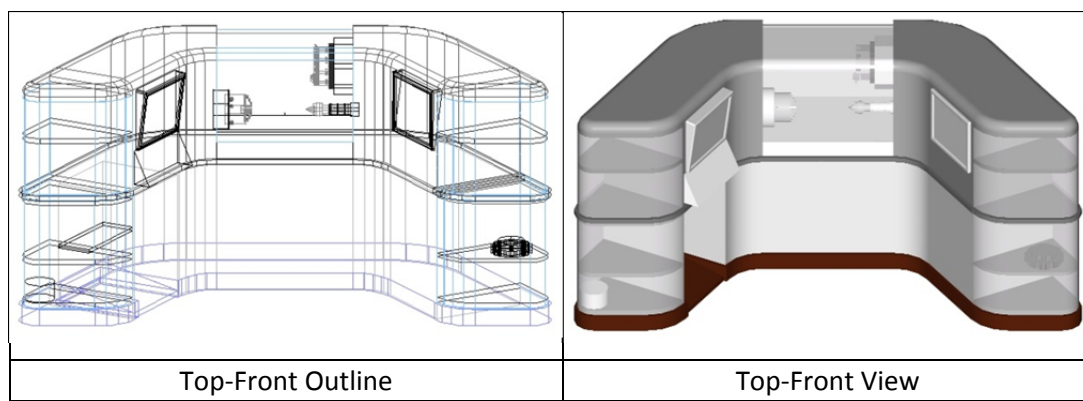

Figure 7: Views of the designed CNC Training Set

Various electrical/electronic circuits will be used at the production of this section's electronic components. Elements such as engine, drivers, and sledges will be used for the mechanical division that processes the parts. Control panel and control unit elements will be used for machine control. After all parts are compiled together on a metal plain, a base software which is prepared in Turkish language shall be uploaded to function as the operating system. Latter to the production of the Mini CNC Machine, the software section of the training set will be incorporated to the machine in a form that it shall be available to be viewed and controlled from another monitor on the machine. The schematic structure of the CNC Training Set is as follows:

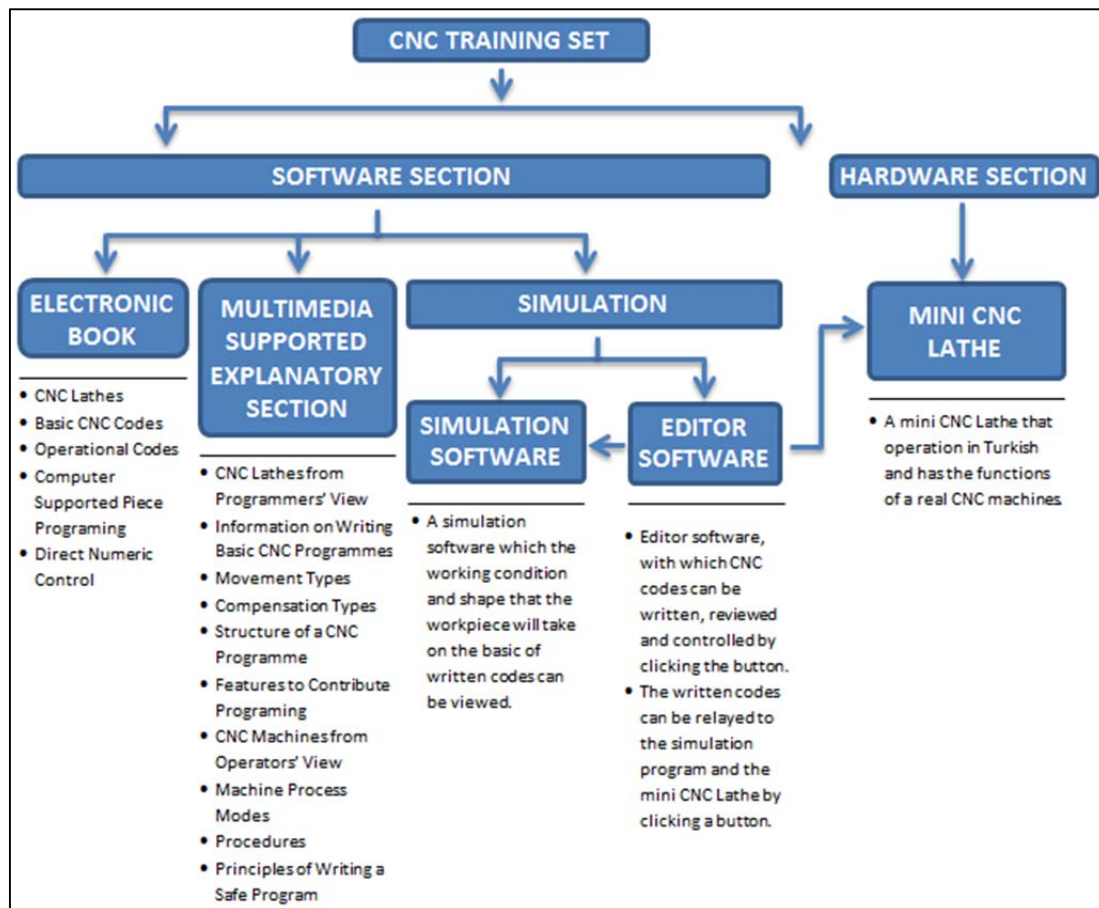

Figure 8: CNC Training Set Design Scheme

Borland Delphi 7.0 Programming Language from Borland Company was used at the development of the software part. The editor program at the simulation section and the e-book section are prepared with this software. This specific program was especially preferred as it is a very elastic and easy-to-use programming language that is eligible to work at various computer types without requiring an additional file. Multimedia Builder 4.9.7 from MediaChance Company is used at the interface of the software part and the multimedia supported narration part to ensure easier visualization. This program is particularly used in developing multimedia supported interfaces and has a simple script language. In addition to those, Adobe Photoshop CS2 for image programming; Macromedia Flash 8.0 for animations, Sony Vegas 6.0 for video editing and Techsmith Snagit 8.0 for screenshots were used. Benefits that can be expected from the CNC Training Set are;

- **A Faster and More Qualified Training:** In comparison with the present classic training types, the training with the CNC Training Set provides a more qualified education with its vivacious and practice-based structure. Lecturing is far easier since the trainer is able to show the machine parts, functions and results of the written codes on the machine. The trainee has the means to receive training with a maximum level of comprehensiveness instead of a training that remains in theory and is tendentious to be forgotten in time.
- **Reduction of Accidents and Malfunctions at CNC Machines:** With the CNC Training Set, the student is able to write the codes on the information screen and see the simulation of the process before forming the part. With this technology, accidents like crashing that would occur as a result of false coding can be foreseen and correction becomes possible. Furthermore, the training made with this set is easier to learn in comparison with a theory-based course as this one provides means to practice. Given the chance to see his mistakes, correct them and re-exercise; the student will naturally make less mistakes during the actual operation.
- **Means to Re-train the Learner:** This set appeals to students from various levels of knowledge. Any student from any level, from a beginner level learner to an actual CNC operator can be trained with this set. A person who has previously received a CNC training or a user who actively operates CNC Machines can take advantage of this training as they can study the topics which they feel they should develop themselves at. In other words, this set provides means to be trained over again on any needed topic whenever deemed necessary. All students, regardless of their knowledge level, can obtain benefits from this designed Set.
- **Positive Approach of the Student and Therefore Easier Concentration on the Lesson:** There will be an actual machine at the lessons with the CNC Training Set. This practice-based methodology, by which a real machine is ready to serve to the learning process, increases the attention towards the lesson. This is a remarkable difference that reinforces the quality of the overall training. The student furthermore, will have a mindset that he

will better comprehend the lesson when he first sees the set. A positive approach towards the lesson will develop by itself, enabling the learner to better concentrate on the course.

• **Cost Saving:** This desktop type CNC Training Set with smaller dimensions naturally has a lower cost in comparison with an industry-type CNC. Purchase of one industrial CNC Machine that will serve educational purposes at schools can be replaced by purchase of several CNC Training Sets.. The training set furthermore shall provide more benefits in comparison with an industrial CNC as it is specifically designed for training.

CONCLUSION AND SUGGESTIONS

Aiming to render CNC trainings more influential and efficient, a specific CNC Training Set was designed in this study to meet educational needs at institutions that provide CNC Training and at industrial establishments that wish to bring in-service training to their employees. The Set is produced except for a few specific sections. Due to cost-related reasons, certain sections of the CNC Training Set could not yet be manufactured. This deficiency will be remedied by project conceptualizing on these sections. As soon as the project proposals presented to particular establishments are accepted and support is obtained, the incomplete parts will also be produced and added to the training set. Presently, the software part that will run on the computer is wholly produced and ready to serve.

Production of the hardware section will further increase the efficiency of the education. At the moment, operation is applicable with simulation. Even though the current simulation media is very similar to the actual production environment, joining of the hardware part shall render the training set quite more efficient as means to sustain a real production will materialize.

With this training set, the overall understanding on CNC Usage Education will upgrade to a more qualified level. Qualified CNC Operators needed by the production industry shall be raised through a practice-based methodology. This designed CNC Training Set is open to further development. Being formed of a modular system, the Set is formed of different and independent sections, enabling third party professionals to add to it or upgrade its current sections. Copyrights of other books can be obtained for e-book section and their electronic versions can be added to this part, for instance. To the multimedia environment on the other hand; vocal, animation or graphic containing features from various sources can be added to achieve a more efficient narration.

Current CNC Training Sources bear various disadvantages such as excluding Turkish language options, being sold at high prices or having other purposes than training. In this study, a low-cost Training Set in Turkish language, designed only for educational purposes is developed throughout which educational principles have been taken into account.

With its advantages mentioned above, the presence of the CNC Training Set at the learning environment will bring remarkable benefits to the educational process in means of reaching its goals. Educational institutions that provide CNC Training and corporations that aim to train their employees on CNC usage will earn significant advantages by using this Training Set.

REFERENCES

- Dinçel, M., (1999). CNC Takım Tezgâhları, Trakya Üniversitesi, Tekirdağ Ziraat Fakültesi, Tarım Makinaları Bölümü Diploma Çalışması, Tekirdağ.
- Ertürk, S. (1979). Eğitimde Program Geliştirme. Ankara: Yelkentepi Yayınları.
- Koçlu, N., (2002). İşletmelerde Hizmet İçi Eğitim Etkinliğinin Değerlendirilmesi - Hipokrat A.Ş. CNC Birimi Uygulaması, Dokuz Eylül Üniversitesi, Sosyal Bilimler Enstitüsü, Çalışma Ekonomisi A.B.D., İnsan Kaynakları Programı Yüksek Lisans Tezi, İzmir.
- Mamur, T., (2005). CNC İşleme Merkezi Teknolojisine Giriş, Anka CNC Servis Departmanı, Retrieved on April 10, 2011 from <http://www.ankacnc.com/teknik/Isleme%20Merkezi/BOLUM1.pdf>.
- MEB (1996). Anadolu Teknik Lisesi ve Teknik Lise Bilgisayarlı Nümerik Kontrol Bölümü Meslek Dersleri Öğretim Programları, Ankara.
- Özdemir, S., Yalın, H. İ. (1999). Öğretmenlik Mesleğine Giriş, Nobel Yayınevi, Ankara.
- Özdeveci, M. (2001). Eğitim Tipi CNC Frezesinin Tasarımı ve İmalatı, Makine Eğitimi A.B.D. Makine Eğitimi Programı Yüksek Lisans Tezi, Fen Bilimleri Enstitüsü, Marmara Üniversitesi, İstanbul.
- Yalın, H.İ. (2004). Öğretim Teknolojileri ve Materyal Geliştirme, Nobel Yayınevi, Ankara.

THE REVIEW OF THE PERCEPTIONS OF SOCIAL SCIENCES TEACHERS ON TECHNOLOGY INTEGRATION

Ozkan AKMAN
Namık Kemal of Secondary School
akmanozkan@hotmail.com

There are numerous factors in the integration of the technologies within the processes of learning and teaching. Numerous dynamics such as the IT instruments, teachers, students, school administrations, education programs and school cultures have effects on providing the technological integration. From the point of the effectiveness of this process, it is important to cooperatively handle the technology applications and the sociocultural context which includes it. The purpose of this study is to determine the perceptions of social sciences teachers on the technology integration. In this research, focus group discussion technique, one of the qualitative research techniques. This study was formed with the question of “What sort of skill does a social sciences teacher need about the technology integration in the classroom environment?” In order to clarify the matter, different questions were asked in addition to the given responses and provided a deeper explanation to the question. According to the results of the research, it was concluded that there were numerous variants on the technology integration (the crowded classrooms, deficiency of infrastructure, administrative problems, etc.), the significance of the competence among the teachers was huge and inter-relations among the teachers were also significant. Such factors determined according to the responses of the participants of this study were discussed and suggestions were made related to those problems.

Key words: technology integration, focus group discussion, teacher competencies.

THE OPINIONS OF THE SOCIAL SCIENCES TEACHERS ABOUT FATİH PROJECT

Ozkan AKMAN
Namık Kemal of Secondary School
akmanozkan@hotmail.com

The FATİH Project is a project prepared in order to provide the most productive courses by furnishing all the schools with technology infrastructure through a contract between the Ministry of National Education and the Ministry of Communications signed in 2010. Using this project, drastic changes are aimed in Turkish teaching system. This study was executed in order to determine the opinions of the social sciences teachers through this project. It was executed through preparing semi-structured interview forms among the qualitative research technique. According to the results of the research, the teachers stated that awareness was created in the teaching environment, an effective teaching was obtained since it addressed more sense organs, provide savings of time since it enabled the information transfer faster and thanks to it, technology literacy increased among both teachers and students. Nevertheless, they also stated that discipline problems in the classroom increased and they had problems in managing the classroom. Since the biggest effect in achieving the success for this project, the success depends on the teachers who continuously adapted themselves during the in-service training.

Key words: FATİH Project, Social Sciences Education, Semi-structured Interview.